



# Automotive Industry

Solutions for production and E-Mobility

# In dialog with customers and partners worldwide

Phoenix Contact is a global market leader in the field of electrical engineering, electronics, and automation. Founded in 1923, the family-owned company now employs around 14,500 people worldwide. A sales network with over 50 sales subsidiaries and 30 additional global sales partners guarantees customer proximity directly on site, anywhere in the world.

Our range of services consists of products associated with various different electrotechnical applications. This includes numerous connection technologies for device manufacturers and machine building, components for modern control cabinets, and tailor-made solutions for many applications and industries, such as the automotive industry, wind energy, solar energy, the process industry or applications in the field of water supply, power transmission and distribution, and transportation infrastructure.

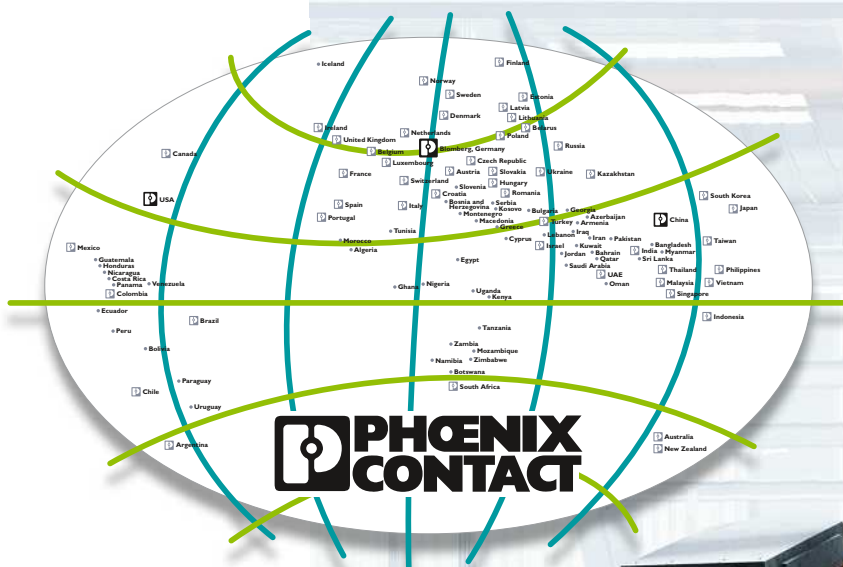

Company independence is an integral part of our corporate policy. Phoenix Contact therefore relies on in-house competence and expertise in a range of contexts: the design and development departments constantly come up with innovative product ideas, developing special solutions to meet customer requirements. Numerous patents emphasize the fact that many of Phoenix Contact's products have been developed in-house.



“For flexible and platform-based manufacturing, the Automotive Industry requires particularly communicative automation technology. Open standards ensure high availability and compatibility of the components used throughout the factory. With this in mind, we rely on standardized interfaces for our solutions. Extensive application know-how, a comprehensive product range as well as tailored services make Phoenix Contact your competent partner.”

*Wilhelm Scholle, Global Industry Manager*



## Contents

Overview: Solutions for the automotive industry	4
Solutions for production	6
– Press shop	8
– Body shop	10
– Paint shop	12
– Powertrain	14
– Final assembly	16
– Conveying technology	18
– Factory infrastructure	20
Solutions for E-Mobility	22
– Charging process	24
Quality is no coincidence	26
– Engineering and control cabinet solutions	28
– Services for functional safety	30
– Service and support	32
– Inspiring industry solutions, thanks to excellent products	34

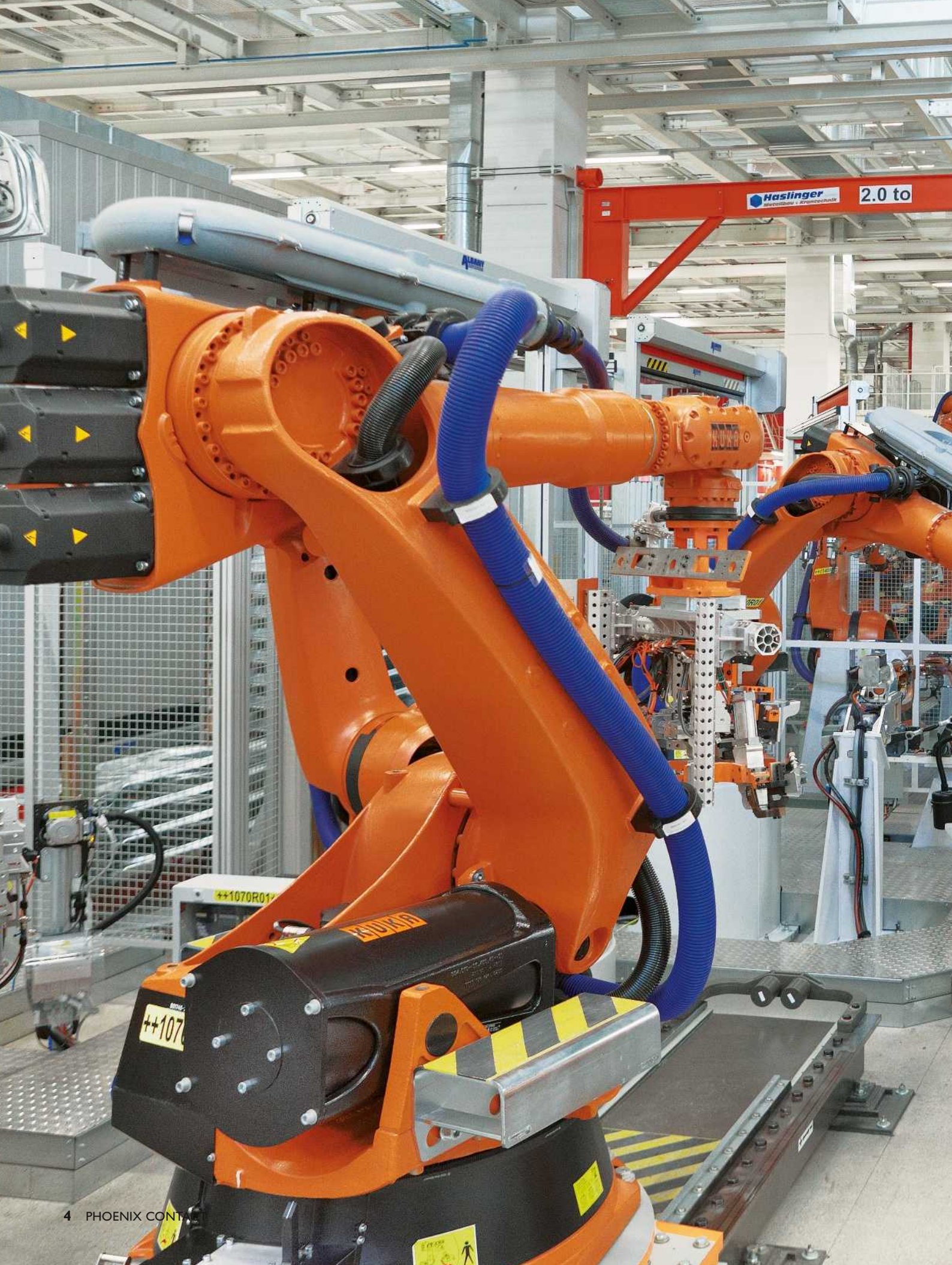



## Overview: Solutions for the automotive industry



### **Automotive production**

Production must be safe yet flexibly adjustable. Open and controllable concepts for the controller and industrial communication are therefore indispensable. Innovative solutions from Phoenix Contact not only fulfill technical requirements, but also bear the environment and people in mind.

*For further information, see page 6 onwards*



### **E-Mobility**

Forward-looking trends such as urbanization and the development of renewable energy sources increase the demand for electric vehicles. Phoenix Contact offers suitable solutions for the charging process. Equipped with charging systems, charging controllers, and components for the charging infrastructure as well as charging management, Phoenix Contact is your end-to-end provider for E-Mobility.

*For further information, see page 22 onwards*



# Solutions for automotive manufacturing

Throughout the complete production process, robust, open, and consistent automation solutions are called for. Of particular importance is secure communication, the functional safety of machinery, consistent diagnostics as well as a high level of availability and processing speed.

As a long-term partner of the Automotive Industry, Phoenix Contact offers fully developed solutions for these individual production areas. The foundation for this is often an automation standard based on a uniform software and operating architecture. Interfaces for planning tools and simple creation of the visualization considerably reduce your engineering costs.

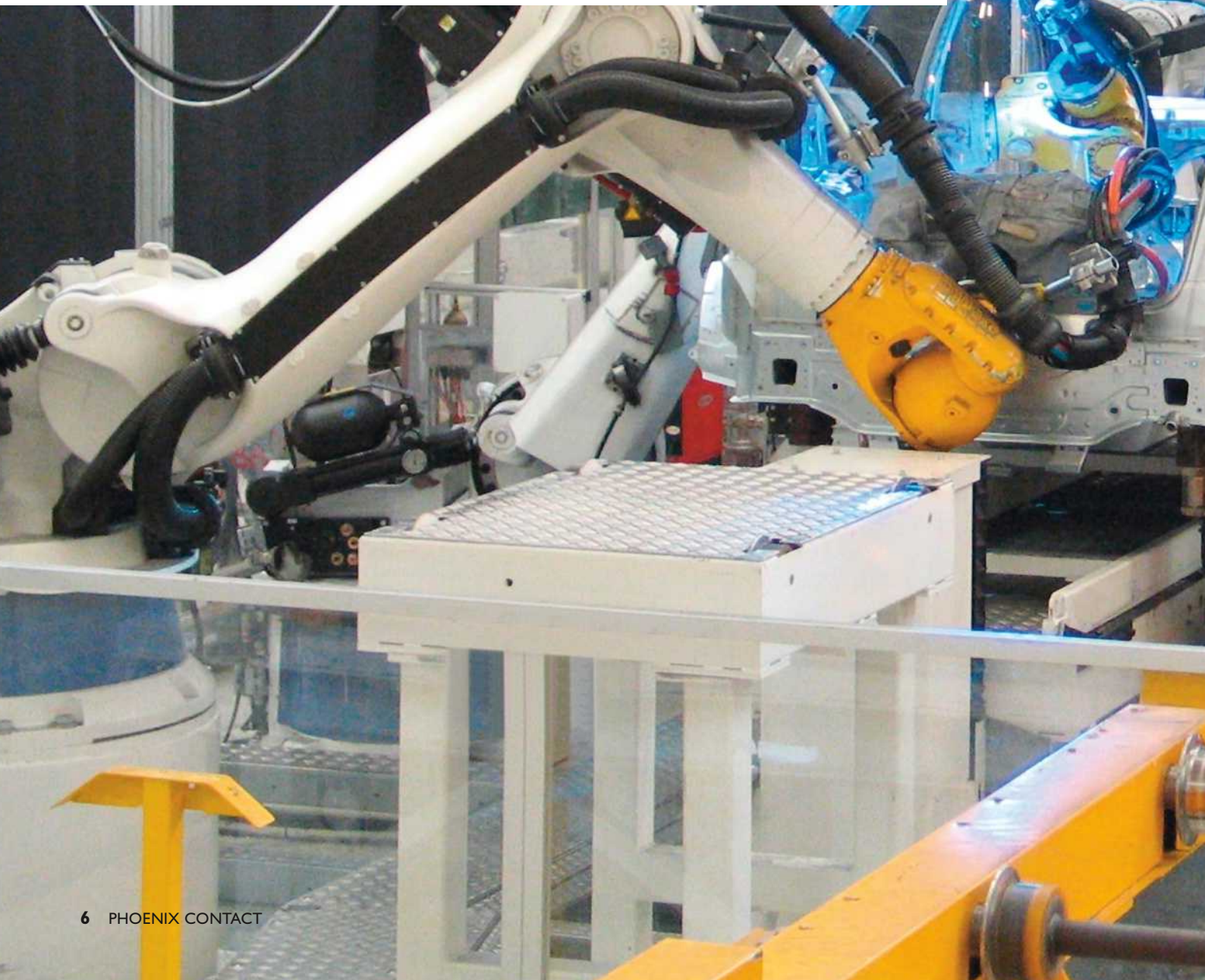



## Overview: Automotive production

### Press shop

Secure communication for high productivity.



### Body shop

Highly-automated processes for variance and fast cycle times.



### Paint shop

Failsafe, thanks to an uninterruptible procedure.



### Final assembly

Ergonomic workstations and data processing for quality assurance.



### Factory infrastructure

Efficient solutions for lighting, extraction, and energy monitoring.



### Conveying technology

Wireless communication and distributed operation for logistics and information processing.



### Powertrain

Distributed automation for surface-optimized manufacturing.





Solutions for automotive manufacturing

## Press shop

The press shop is a long-term, considerable investment. Its job is to press and punch car body parts from sheets of different materials at high speed and with a high degree of precision. In addition to the physical requirements placed on vibration resistance, the technical solutions require highly reliable and most importantly secure communication.

Phoenix Contacts offers data security by means of security and remote maintenance concepts as well as individual solutions for the safety of machinery.

### Your advantages:

- Fail safety, thanks to robust products with a high degree of shock and vibration resistance
- Secure communication with encryption technology
- Cost-saving and efficient maintenance concepts for distributed system access
- Safety of machinery, thanks to a control and network-independent safety concept

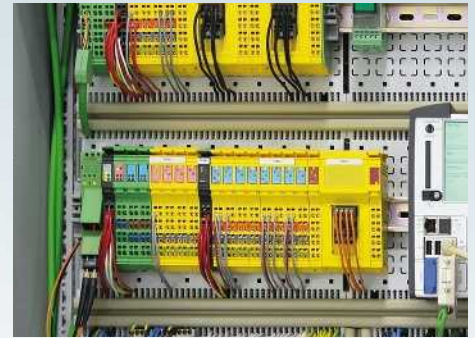

### Secure communication

Sensitive system data and demands for the highest possible availability call for a high degree of security in terms of the data transmission.

Security routers from the FL MGuard product range offer an optional anti-virus scan connector in addition to security mechanisms such as VPN tunnel.

### Remote maintenance and diagnostics

Remote access and continuous process data monitoring allow maintenance to be planned and optimum system availability.

Secure remote maintenance connections allow your specialists reliable access with fast response times.

### Reliable condition monitoring

To monitor the condition of the system, reliable and secure signal paths are required. SafetyBridge technology offers a network and control-independent safety solution. Using standard automation networks, safety-related signals can be transmitted and evaluated without the need for a safety controller.

### Secure solutions for the production process

A high level of system availability is paramount to production processes. With this in mind, Phoenix Contact offers sophisticated solutions for a secure remote maintenance concept. The FL MGuard router protects your system against unauthorized access by people or malware.

Heavy weights are moved in a press shop. The risks associated with these weights place maximum requirements on the protection of machinery personnel. SafetyBridge enables safety solutions to be implemented at the maximum performance level PL<sub>e</sub>.

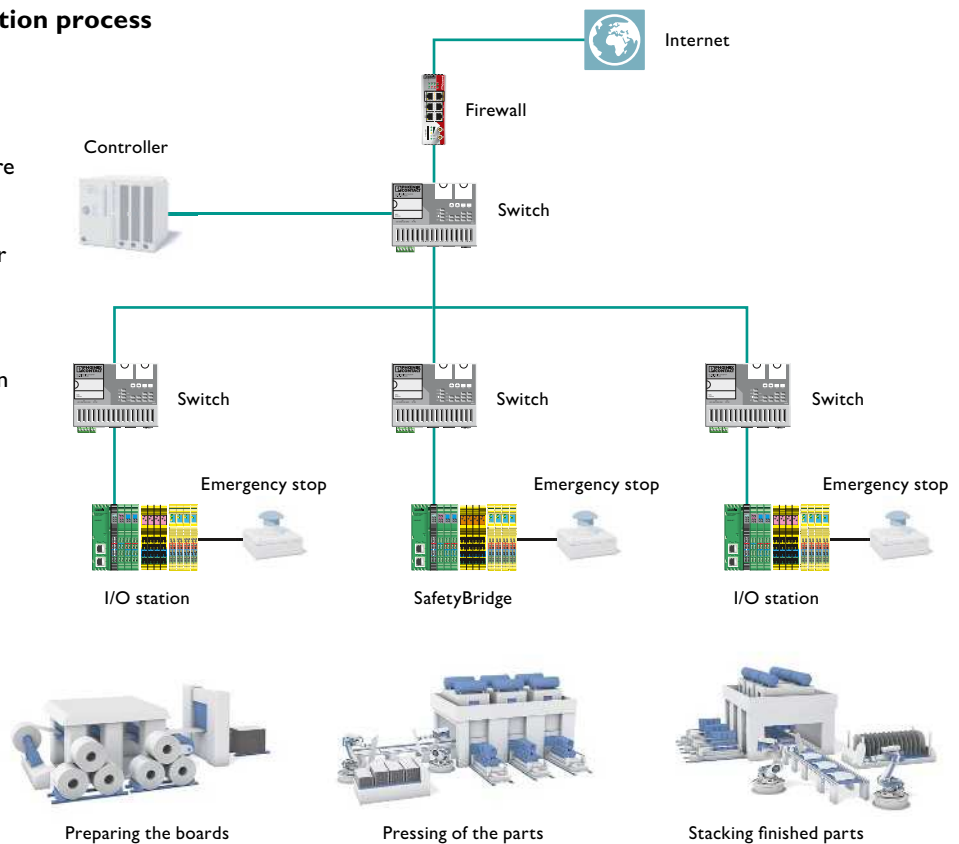

— Ethernet

Solutions for automotive manufacturing

## Body shop

In body shop, the widest range of car body versions are realized without interruption and influencing the cycle time.

Our special automation solution which is able to communicate ensures the optimum information flow for high productivity, flexibility, and quality in manufacturing. Network products and controllers from Phoenix Contact work with recognized IT standards. This pays off during integration into the engineering processes and ensures fast product startups.

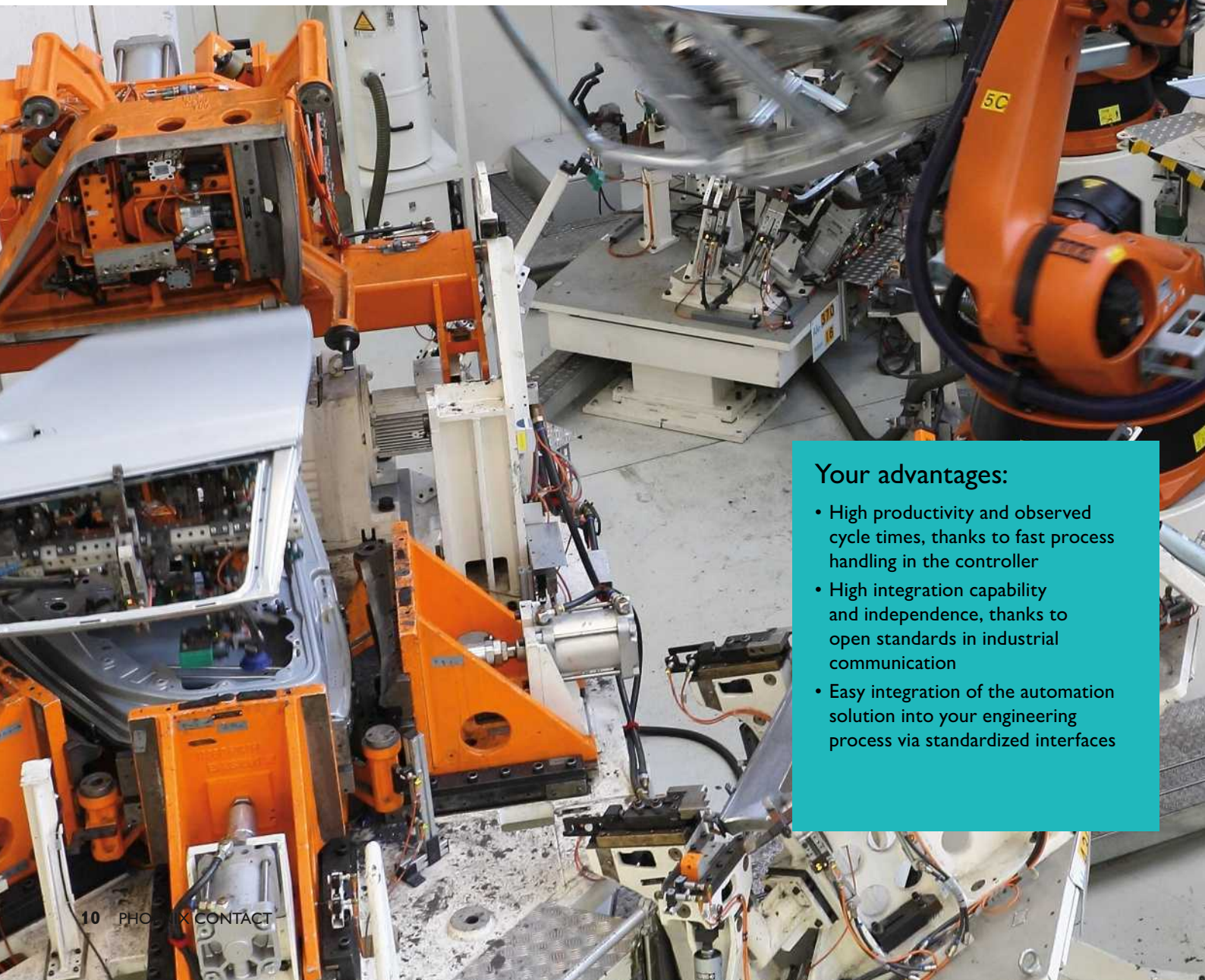

### Your advantages:

- High productivity and observed cycle times, thanks to fast process handling in the controller
- High integration capability and independence, thanks to open standards in industrial communication
- Easy integration of the automation solution into your engineering process via standardized interfaces



## Operating station

Operation in highly automated production is also a decisive productivity factor.

In line with your requirements, together with you, we determine individual concepts for operating stations: from the hardware used, right through to the programming and visualization software. In connection with standardized user interfaces, the systems ensures maximum orientation.

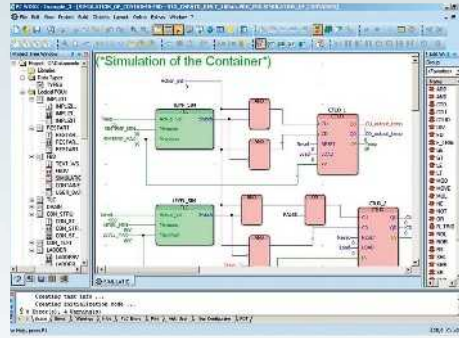

## Software architecture

From planning, to startup, through to safe operation: the consistent architecture of the application software considers the special features of each production life phase.

Phoenix Contact offers various function and visualization blocks based on this architecture. Along with the automatic visualization, you will be offered a cost-effective solution in no time at all.



## Reduction of base load

Pause times are integrated into the robot cells, e.g., during tool change or regular recovery times. PROFINET controllers from Phoenix Contact allow you to automatically switch off and back on required loads or technologically corresponding system parts during periods of no production via PROFIenergy. This saves energy and money.

## Automation concept

Recurring joining processes are at the heart of body shop. The systems are separated for the production of certain body shop parts and are protected via firewalls. Vehicle information is forwarded to the system or cell via Layer 3 switches. Controllers such as the RFC 470S PN regulate the process sequence while simultaneously protecting protective circuits.



Joining  
(chassis, side parts, etc.)



Framer  
(joining to car body)



Joining the flaps and finish

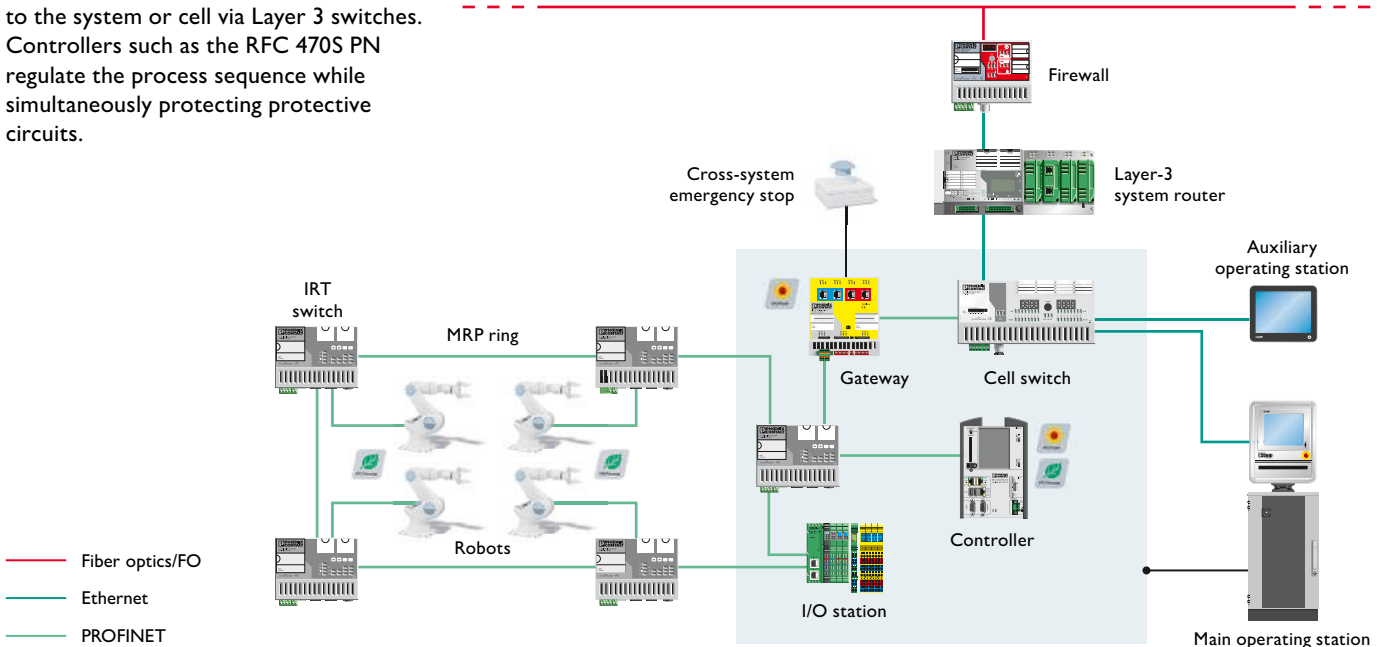



Solutions for automotive manufacturing

## Paint shop

In many areas, transport, handling, and painting must be performed without interruption and in a highly automated manner. During the painting process, various materials are used in the widest range of ambient conditions. The prerequisites for the quality and efficient use of these materials are data transparency and flexible industrial communication technology.

Automation technology from Phoenix Contact supports these extensive tasks right through to process technology.

### Your advantages:

- Reliable processes, thanks to flexible communication networks
- Uninterruptible procedure, thanks to redundant controller, power supply, and network concepts
- The best possible sustainable parameterizations for high-quality painting

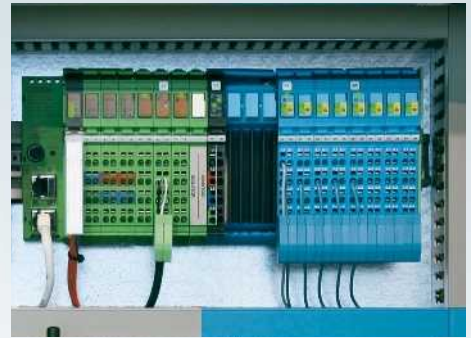

## Redundant networks

Failsafe automation systems are a must for the drying process. The solution is to use redundant control concepts based on our RFC 460R high-performance controller. If one controller fails, the other controller takes over control of the function immediately. As such, you can ensure that automation functions smoothly on your painting line.

## Redundant power supplies

If the energy supply to system parts or even individual components is briefly interrupted, this can result in failure of the thermal procedure. To prevent damage to the system and product, redundant power supply concepts ensure reliable supply of the automation components.

## Explosion protection

As a result of the materials used in paint shops, an explosive atmosphere is to be expected.

Phoenix Contact offers intrinsically safe Ex i I/O modules which can be mounted behind the supply terminal. There is a large selection of standard I/O terminals for use in potentially explosive areas up to zone 2 available for this purpose.

## Redundancy means safety

Even in paint shop process engineering areas, a failure would mean considerable damage to products and systems. The solution is redundancy on a network, power supply, and control level with our RFC 460R controller. Thanks to AutoSync Technology, designed by Phoenix Contact, two RFC 460R controllers automatically configure and synchronize all the redundancy functions.

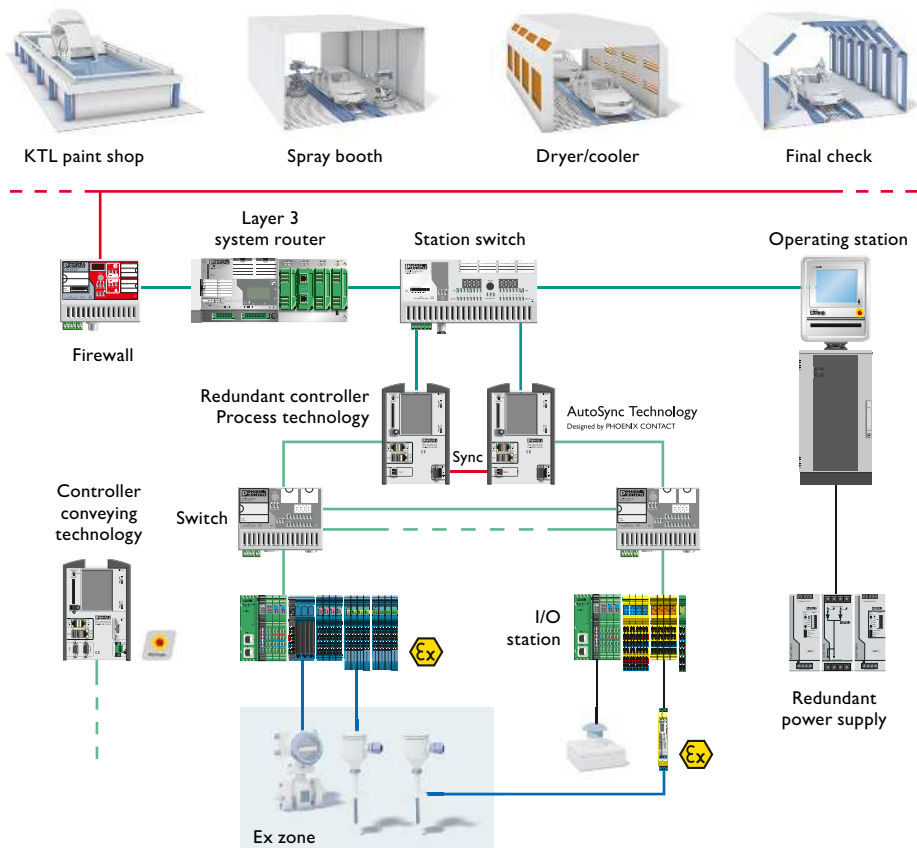

Solutions for automotive manufacturing

## Powertrain

In parallel with the car body, the drive unit is manufactured with a motor, gearbox, axes, and drive shaft. It is here where efficient system operation comes into its own. In order to respond to changing customer demands and to keep the time to market factor low, manufacturing must be as flexible as possible.

With this in mind, Phoenix Contact offers distributed, space-saving automation solutions. In addition, we support you with software products and services for fast product startup.

### Your advantages:

- Surface-optimized manufacturing, thanks to the integration of distributed automation technology into the system geometry
- Fast startup due to open software standards and supportive parameterization tools
- Reduced power dissipation, thanks to short cable routes

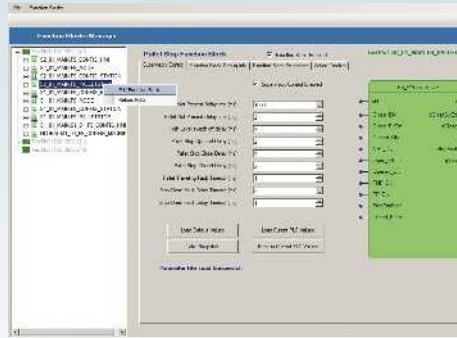

### Intelligent 24 V distributors

The decentralized distribution of the 24 V supply voltage reduces power dissipation on the cables and at the same time lowers the number of devices to be supplied. For this purpose, Phoenix Contact offers a suitable combination for high-quality supply and diagnostics.

### Easy startup

A fast startup calls for a corresponding overview of the parameters to be set, such as speeds, times, measuring ranges, and IT configuration. The Lineworx parameterization software scans the user program and guides the user through the settings or adjustments to the system.

### Distributed signal acquisition

Acquire input and output data in your system during manufacturing. Axioline E allows you to flexibly connect to the network. As well as various digital functions, the robust I/O modules with IP65/67 protection also offer an IO-Link master for every network.

### Distributed automation

The manufacturing of drive units calls for plenty of space. It must therefore be possible to integrate automation components into the system. The distributed automation ensures high-quality production areas for valuable processes by means of pre-manufactured function modules. Peripherals such as I/O modules with IP67 round off the decentralization through to the IO-Link-capable sensor. This point-to-point connection enables you to exchange both process data and service data between the connection and sensor/actuator.

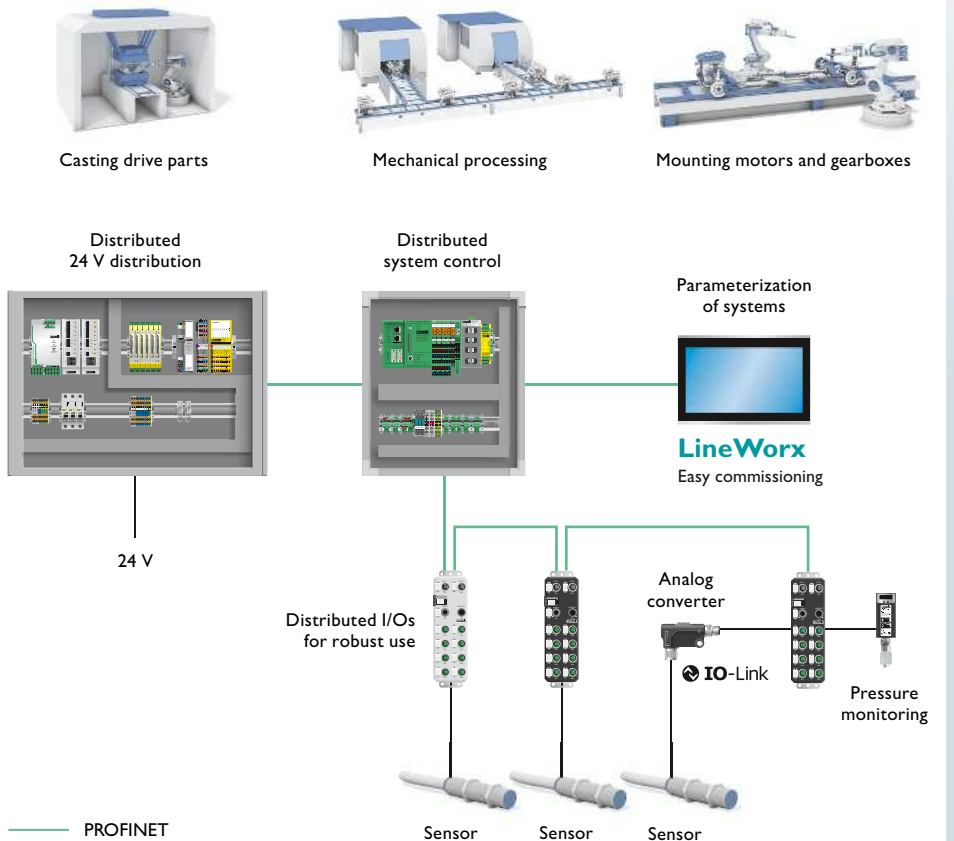



Solutions for automotive manufacturing

## Final assembly

In the final assembly, the car body and drive train are brought together in the so-called marriage. Personnel and machinery also mount the seats, cockpit, wheels, and disks. A fully tested automobile is then ready to be sold.

Automation solutions from Phoenix Contact support perfect ergonomics and operation in the case of manual installations. They ensure precise logistics and mounting processes with fast, reliable streams of information.

### Your advantages:

- Easy maintenance and replacement parts storage, thanks to use of standard products
- Quality, due to visual support of the mounting processes
- Cost-effective pre-processing of data in process-regulating controllers



## Working height adjustment

The adjustment of the working height supports optimum installation of components into the vehicle in terms of ergonomics and quality. Our concepts developed with standard components extend right through to complete control boxes. The complete solution processes station data, adjusts the working height, and is equipped with extensive diagnostics. It is therefore easy to maintain and handle.

## User guidance

In order to satisfy every possible order option of a vehicle, displays and systems from Phoenix Contact support the manual installation of components, such as radios. Panel PCs from the Phoenix Contact Designline series offer powerful technology in attractive, compact housing with all-round IP65 protected housing.

## SQL data coupling for quality data

When transporting large quantities of data, reliability and speed are crucial. For processing and archiving in an SQL database, the controller handles the process-monitoring data on site even without complex middleware. For this purpose, operating data are transmitted directly from the controller to a higher level database.

## Controller and communication

In addition to their control function, our small-scale controllers control communication via various IT protocols. For the visualization, for example, the internal web server is used. Files can be written and read via the FTP. Connection to an SQL database is possible with minimal programming efforts.

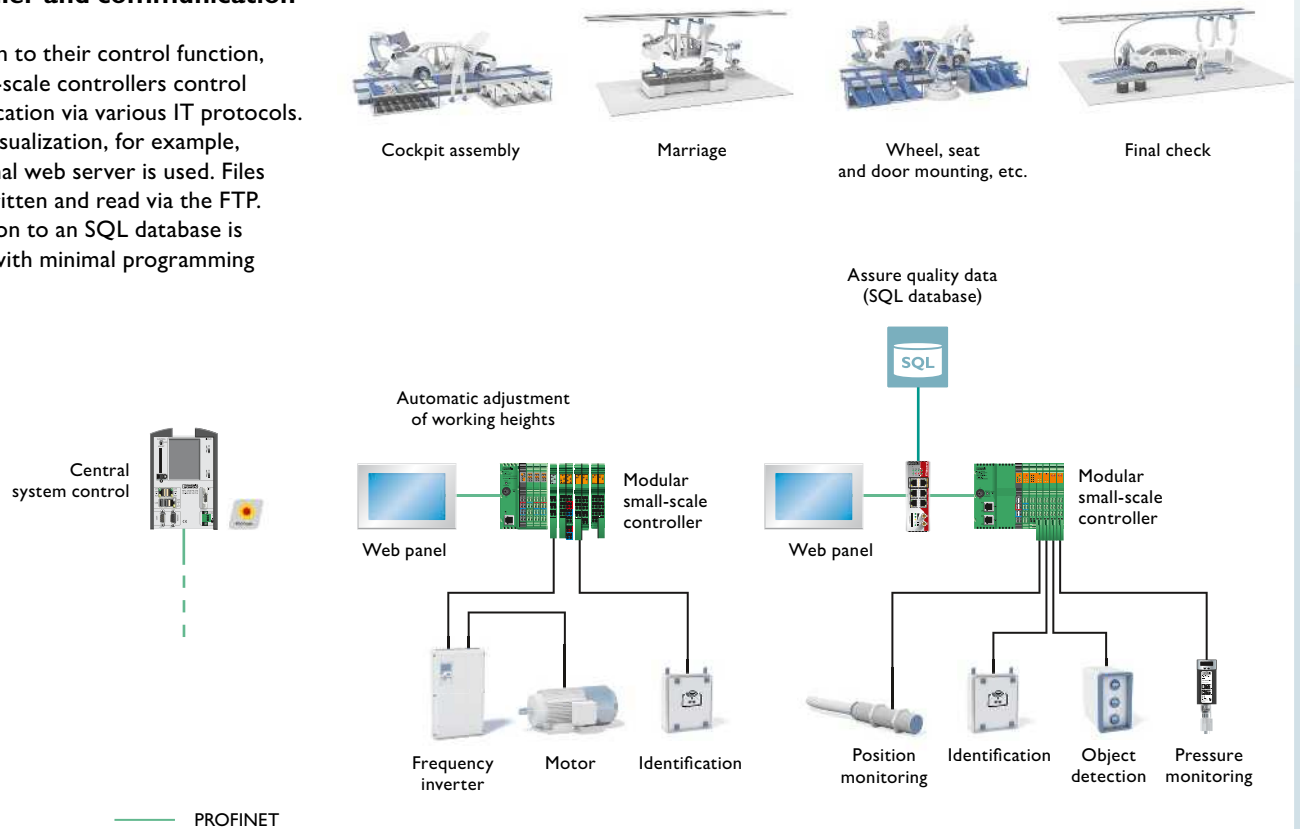

Solutions for automotive manufacturing

## Conveying technology

Throughout the entire automotive production process, the right materials need to be provided to the right production processes at the right time. It is especially due to the wide variety of versions that there are high demands in terms of the availability and information processing in the mobile systems.

Solutions from Phoenix Contact enable cost-effective engineering of the visualization and the selective operability of logistics processes. Our wireless communication concepts support reliable material transport.

### Your advantages:

- Cost-effective engineering through a selectively operating visualization wizard
- Low-wear and low-loss switching of drives
- Installation cost savings, thanks to reliably tested wireless technology

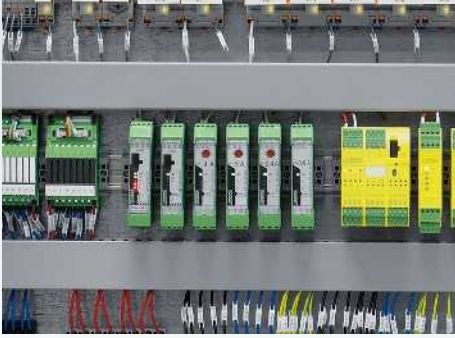

### Safely switching drives

Not all drives in conveying technology need a frequency inverter. Thanks to the CONTACTRON hybrid motor starter from Phoenix Contact, drives can be switched and monitored with minimal wear and losses. This motor control solution enables particularly fast, easy integration into the fieldbus system. In the event of an emergency stop, the power is safely shut down.

### Wireless communication

In conveying technology, hard-wired communication is often rather expensive and requires a great deal of maintenance. Phoenix Contact offers proven wireless solutions, e.g., for data transmission in an electric monorail system and overcoming the limitations of a cross conveyor.

### Distributed operation

The Machinery Directive only permits the operation of areas which are visible. This stipulation proves challenging for remote systems with automatically generated visualization. Consequently, Phoenix Contact has developed Viswiz, the selective visualization wizard. This provides you with the right visualization in the right place.

### Integral conveying concept

Conveying technology extends through all manufacturing areas of a vehicle production line. Various automation applications can be run wirelessly: from floor conveying vehicles, to skid systems, through to electric monorail systems. Our solutions are based on a wide range of expertise from previously completed projects. They also feature the safe switching of motors and operation designed with the viewing area in mind.

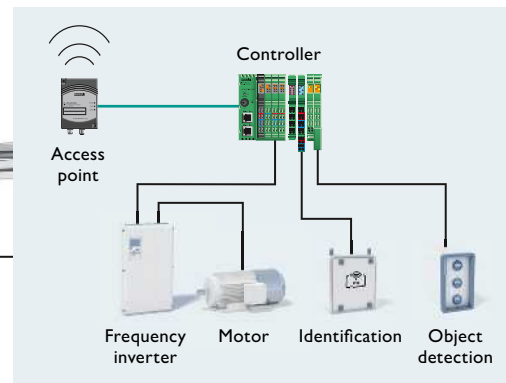
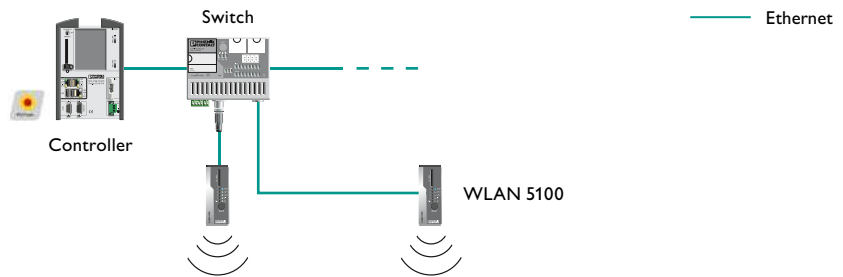

Solutions for automotive manufacturing

## Factory infrastructure

The factory infrastructure primarily supports the production process. With increased requirements placed on energy efficiency, infrastructure is certainly gaining ground. Power, water, gas, and heat must be available at the right time, in the right quantity. Furthermore, the resources used in buildings and in production and those being released are to be automatically coordinated between the areas. Phoenix Contact supports this with concepts and products tested in the field.

### Your advantages:

- Optimum lighting and condition-based energy consumption, thanks to intelligent lighting control
- Sustainable use of existing resources, thanks to scalable monitoring solutions
- Energy savings by means of standby solutions

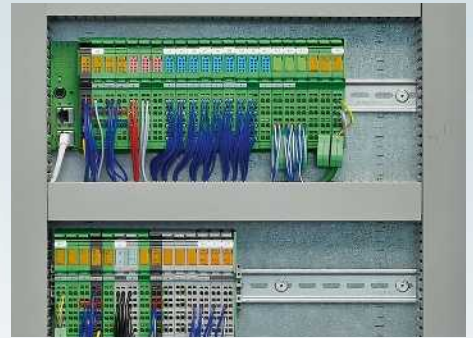

### Condition-based extraction

Welding gases are damaging to health and must be extracted. To save energy, the extraction system should only be operated when the gases occur during production. When it comes to these requirements, along with small-scale controllers and current transformers, Phoenix Contact also offers retrofittable standby concepts with an extremely fast payback period. They also prevent the extraction of heat energy.

### Energy management

Use appropriate energy management to identify great potential cost savings for the cost-effective and environmentally-friendly operation of your machines and systems. Energy flows must be identified to be able to do this. Phoenix Contact offers monitoring solutions for energy and power measurement, which can be scaled in line with requirements and enable integration into existing systems.

### Light control

Light is now used selectively and efficiently where it is actually needed. Save energy by illuminating only the areas where people require light. Phoenix Contact facilitates planning, startup, and operation of factory lighting using web-based configuration and networking of light control.

### Solutions for energy efficiency

From the energy supply, to the building, through to parking lots: a well-designed factory infrastructure is at the heart of automotive production. Phoenix Contact offers sophisticated concepts for this purpose. Lighting needs are determined and controlled for cross-production area lighting, depending on natural light and production requirements. In the case of extraction units, standby mode ensures efficient use of energy.

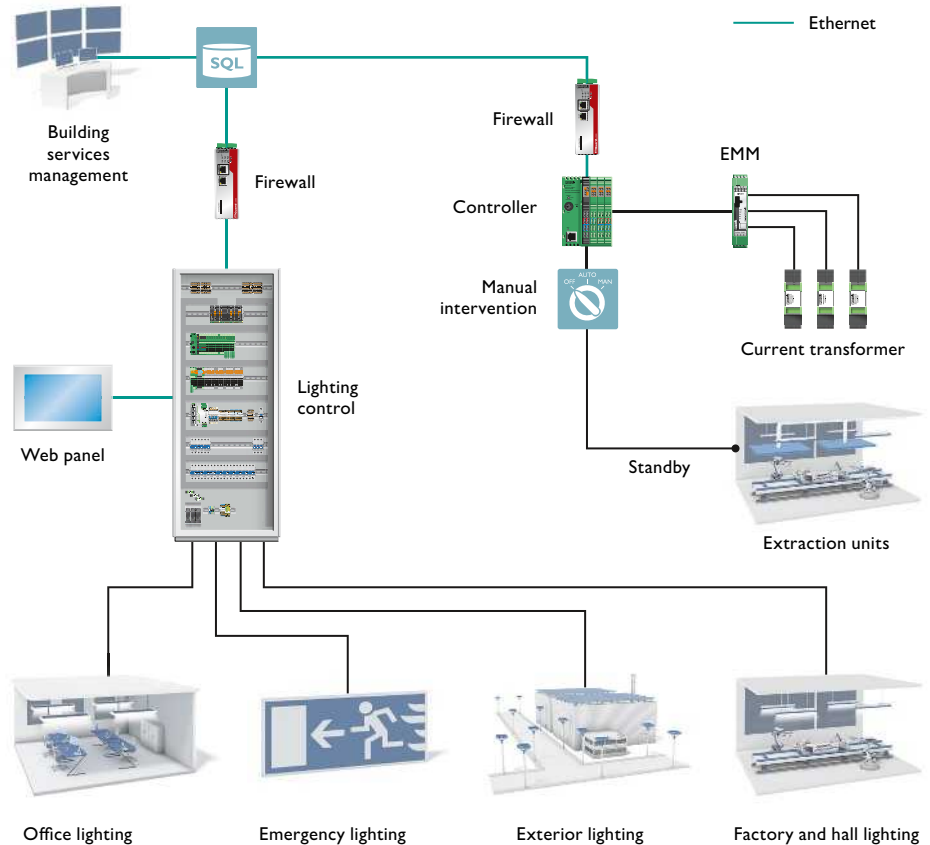

# Solutions for E-Mobility

Charging systems and charging controllers for E-Mobility are globally standardized for residential, commercial, and public use.

The consistent range of products and technology from Phoenix Contact is developed with these standardized specifications in mind. Among these are charging systems and charging controllers for AC and DC charging, charging interfaces for electrically operated vehicles or software blocks for operating the charging infrastructure.





## Overview: E-Mobility

### Charging process

Standardized charging systems and controllers, vehicle interfaces as well as intuitive charging management using software blocks.



## Charging process

There are three standards defined for the charging of electrically operated vehicles on the global market: the type 1 standard for vehicles on the American market, the type 2 standard for the European market, and the GB/T standard for China. Each standard enables conventional AC charging and fast charging with direct current (DC). For the charging process, we provide flexible charging interfaces, high-quality charging cables as well as an intelligent controller and monitoring system, which all correspond to these standards.

### Your advantages:

- Reliable connection technology, thanks to standardized charging systems for all markets
- DC fast charging with the Combined Charging System (CCS)
- Flexible, programmable charging controllers
- Support for your individual charging management
- Complete product range for setting up a modern charging infrastructure





### Charging interfaces

CCS Vehicle Inlets with only one pin connector pattern enable fast DC and conventional AC charging. Vehicle Inlets with uniform external contours and the same screw points for the country standards of type 1 and type 2 provide vehicle manufacturers with a high level of flexibility when it comes to equipping electric vehicles. The universal Vehicle Inlets are easy to configure for commercial and special vehicles.

### Charging infrastructure

A broad product range forms the basis for the development of an individual charging infrastructure in line with demand. For this purpose, Phoenix Contact offers charging cables, Infrastructure Socket Outlets, AC and DC charging controllers, and residual current monitoring of the charging infrastructure.

### Charging management

Charging controllers with standard interfaces enable individual design of the charging infrastructure. With software blocks from Phoenix Contact, you can implement charging management, intuitive user handling, and integration into billing systems with OCPP (Open Charge Point Protocol) or SQL.

### Combined charging system (CCS)

The Combined Charging System (CCS) is a standard-compliant charging system for electric vehicles, which supports both conventional AC charging and fast DC charging. Both Vehicle Connectors fit into the CCS Vehicle Inlet. The DC contacts, which are larger than those used for AC charging, and an integrated cooling system, enable fast charging at up to 350 A.

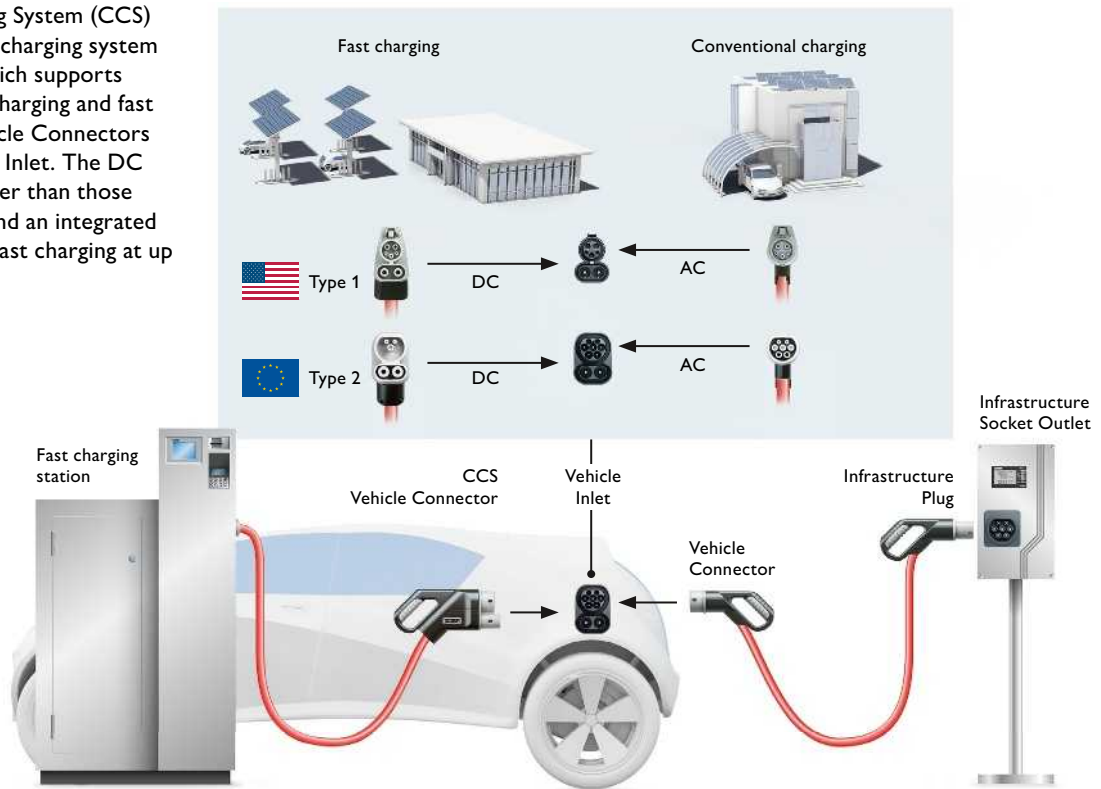

# Quality is no coincidence

It is only when you keep sight of every little detail that you can be sure of the quality of the entire product. For this reason, we not only manufacture our screws ourselves, but also develop tailor-made software and offer engineering services from industry professionals.

This allows us to ensure our commercial and technological independence and gives us the freedom to develop new industrial solutions. You benefit from this because, for example, we are able to offer you pre-assembled control cabinet solutions.

These are specially tailored to your industry and have all necessary certification and approvals. "Made by Phoenix Contact". For us, this means the best quality in every product, in every discussion, for the entire solution.

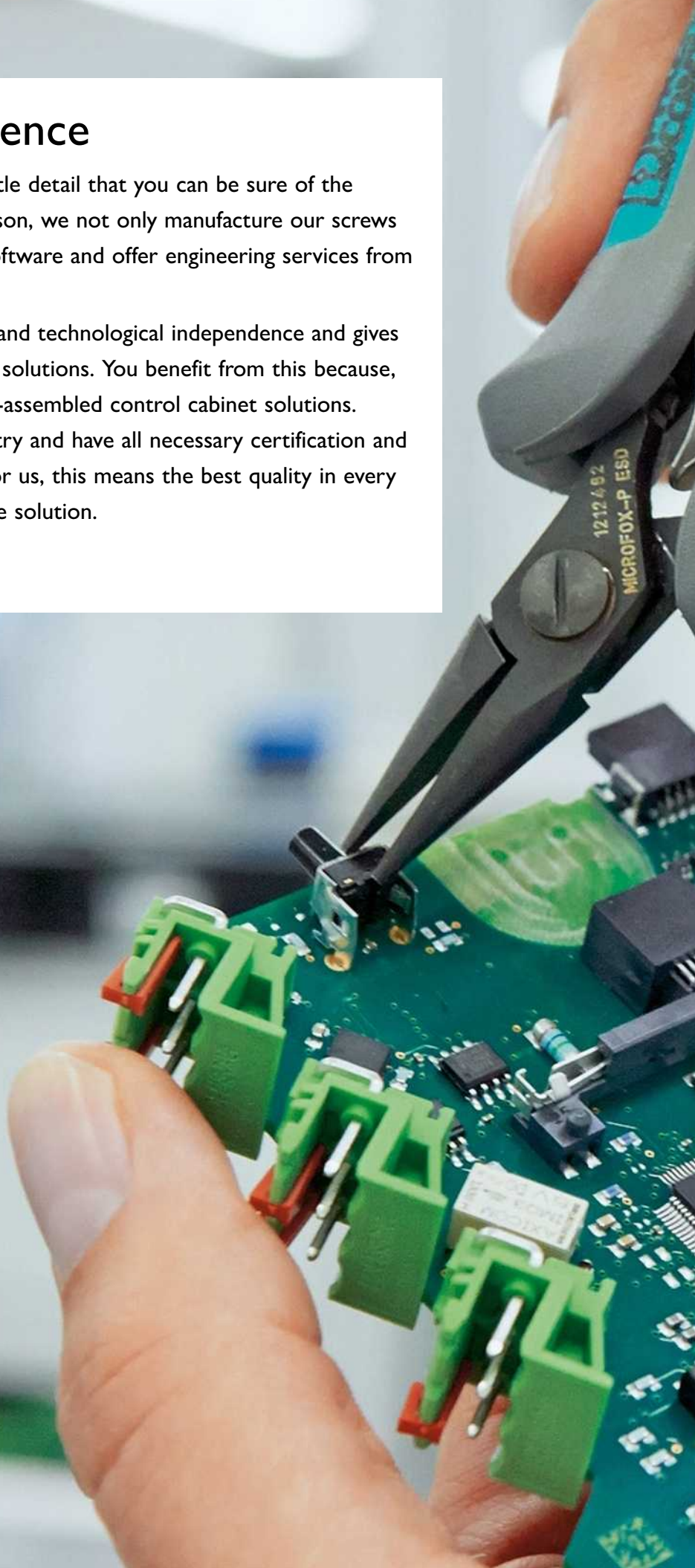

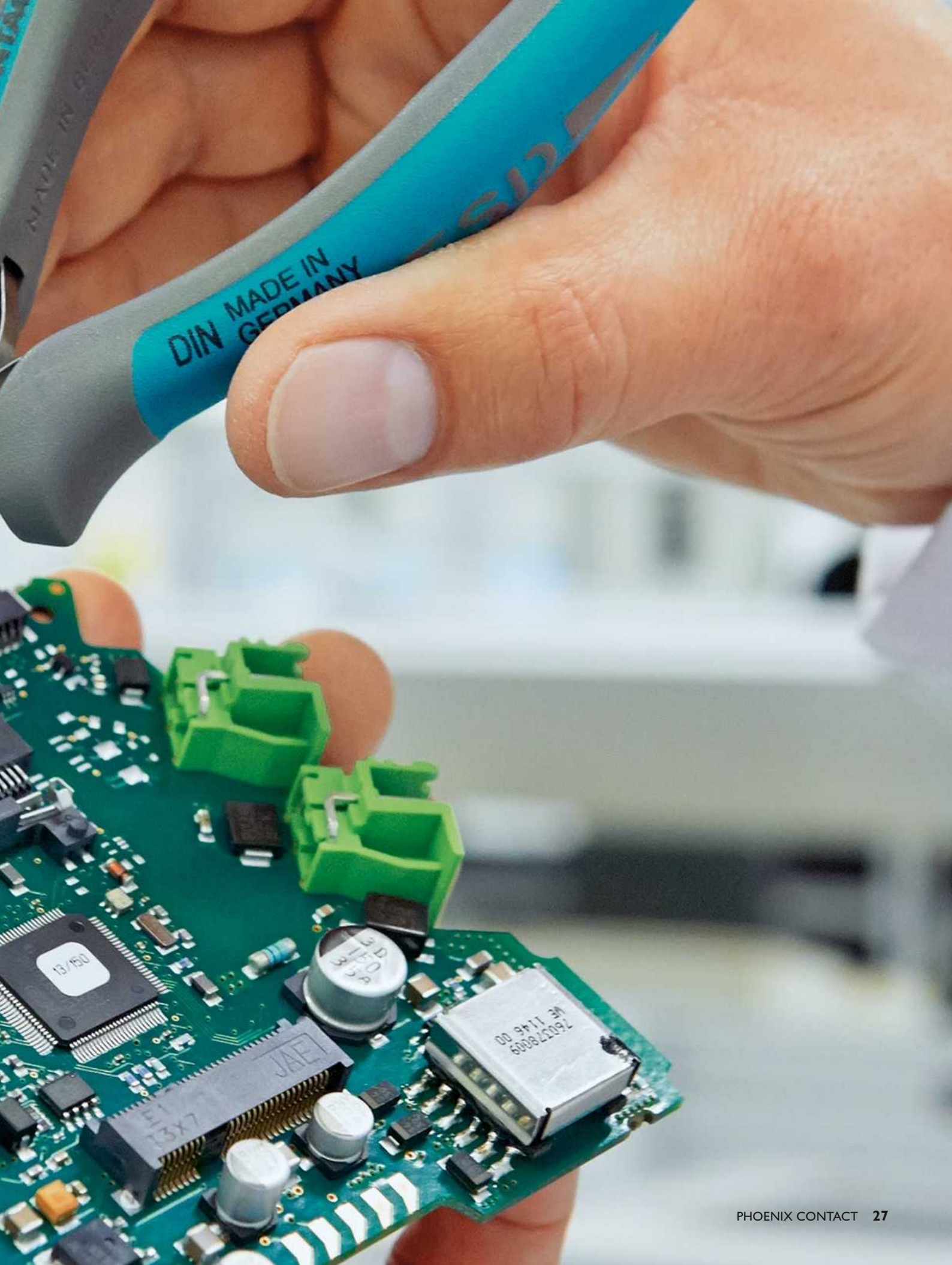

Quality is no coincidence

## Engineering and control cabinet solutions

We set the highest standards for your industry solution: everything is tested and certified from the prewired and preprogrammed control cabinet solution up to the engineering service. Our industry experts advise you during every phase of your project cycle and if required, take over the engineering of your system.

All Phoenix Contact components are tested intensively in the independent and accredited Phoenix Testlab. Control cabinet solutions are conceived and engineered according to the required standards and directives. This allows you to be sure that our finished solution products meet the highest requirements.

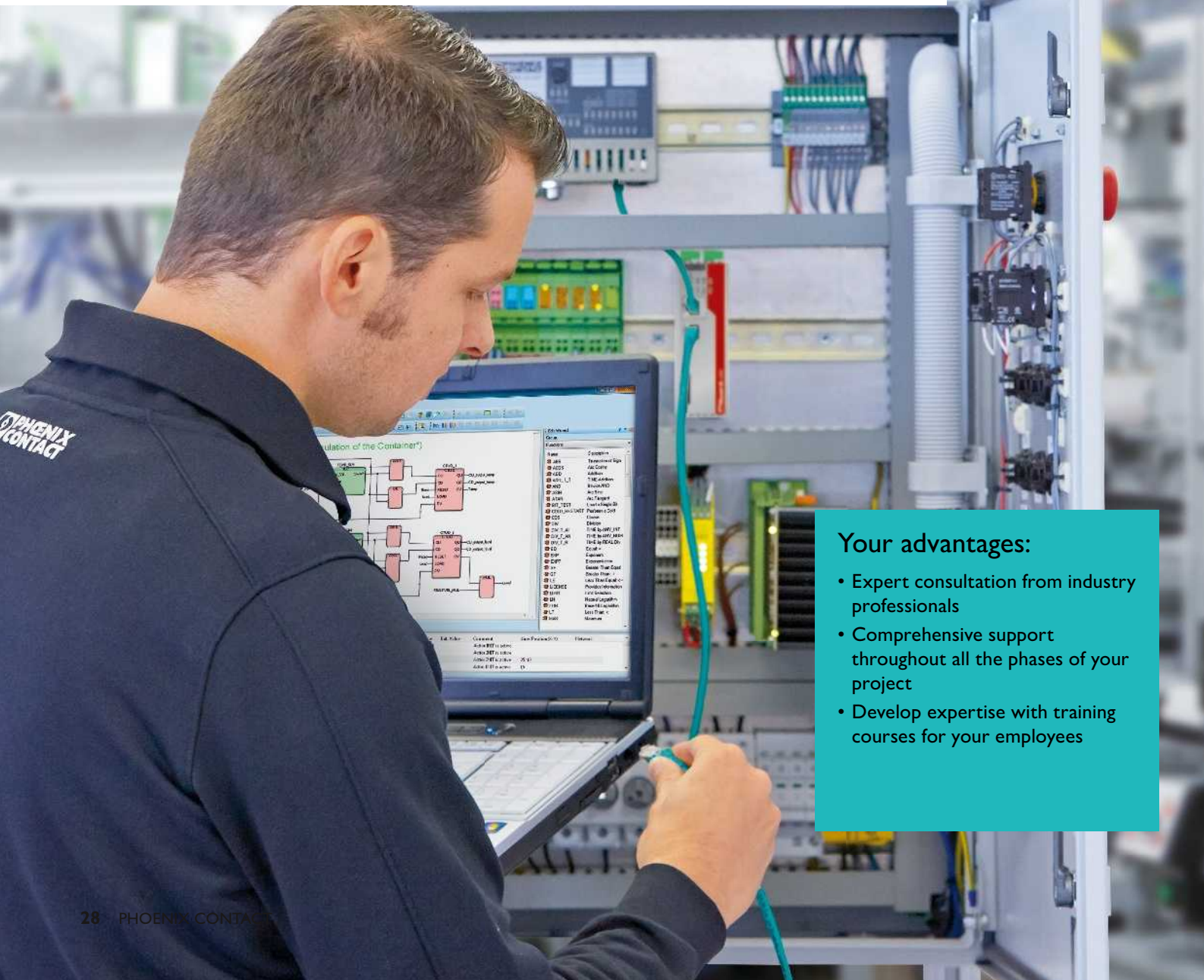

### Your advantages:

- Expert consultation from industry professionals
- Comprehensive support throughout all the phases of your project
- Develop expertise with training courses for your employees



## Engineering

Based on the typical phases of an automotive project, we provide support by working with you at each stage. Simply give us an outline of the application you would like to implement and we will provide you with a technical concept that includes suitable hardware and software:

- Configuration
- Programming
- Visualization
- Coaching

## Control cabinet solutions

We develop control cabinet solutions together with our customers that, depending on the requirement, are already ready to use or prewired so that you are able to carry out final installation.

This allows specific industry solutions from a partner network made up of proven control cabinet manufacturers that meet the highest requirements.

At the same time, the quality is ensured at every step of the development process. A process-oriented, integrated management system based on the international standards DIN EN ISO 9001 and 14001 ensures that legislation and standards such as EU directives 2002/96/EC (WEEE) and 2002/95/EC (RoHS) as well as customer specifications are taken into account during product manufacturing.

## Quality from planning to production

During preliminary development clarification, all divisions work closely with customers. After clarification and the construction phase, the prototype undergoes specific testing. The knowledge gained is integrated into product optimization.

As part of project processing, we support you during the development of solutions: from initial planning and configuration, to layout and construction, through to the evaluation and testing of the specified standards as well as making the documentation and EPLAN-based circuit diagrams available. After that, production planning and control follows and if necessary, series production.

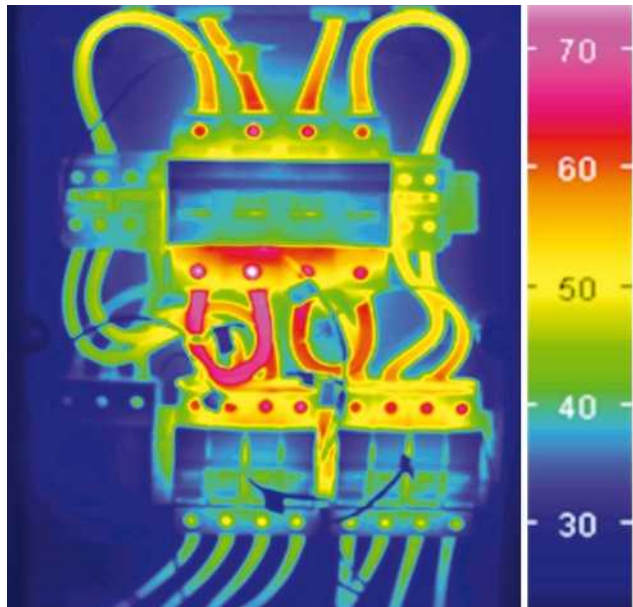

Quality is no coincidence

## Services for the safety of machinery

In addition to the comprehensive functional safety product range, Phoenix Contact supports you with an individual range of services for safety of machinery in the Automotive Industry. Whatever the product, our industry experts help you regarding any questions on conformity assessment (CE) and to plan and implement the safety lifecycle according to EN 62061 or EN 13849. Moreover, we will provide you with the relevant expertise on the safe operation of machinery.



### Your advantages:

- Comprehensive support from industry professionals
- Flexible help during all project phases
- Time savings, thanks to outsourcing
- Building competence through employee qualification



## Product support

We provide individual support when using the safety hardware and software components from Phoenix Contact:

- Correct installation and function check of the safety components during startup
- Shift assistance in the start-up curve
- Introducing operating personnel to the function of the safety components
- Concept developments for sub-systems in the Group standard
- Concepts testing

## Engineering

In the case of requirements according to the Machinery Directive, we implement the required steps for the safety of machinery:

- Modular safety concepts and standardizations for safety-related programming
- Wiring examples and implementation in E-plan
- Software reference projects
- Performance level certification with SISTEMA
- Machine inspection for system acceptance

## Seminars and consultation

We provide you with the required expertise, both in theory and in practice, on the following topics:

- PROFIsafe for machine building and servicing
- FS Technician for Machinery with TÜV Rheinland certificate
- Safety of machinery for safety specialists
- Safe operation of machinery

## Safety services for the machine lifecycle

### Reliable placement on the market

Even during the machine planning phase, the stipulations of the Machinery Directive should be considered for the conformity assessment process. As such, after the risk assessment, you can turn to our safety experts for assistance.

We would be delighted to support you throughout the entire safety cycle for machinery and the resulting requirements placed on the safety of machinery.

Our phase model for the safety lifecycle is based on the harmonized standards of the Machinery Directive. The safety lifecycle represents a process, that when implemented, allows you to fulfill the requirements of EN ISO 13849-1 or EN 62061 for functional safety.

### Safe operation

Furthermore, we will support you in the safe operation of your machines and systems, as if any modifications or links are made, these must be re-considered from a safety technology perspective. Due to varying national legislative powers for

occupational health and safety, there are stipulations to be observed for the safety of machinery.

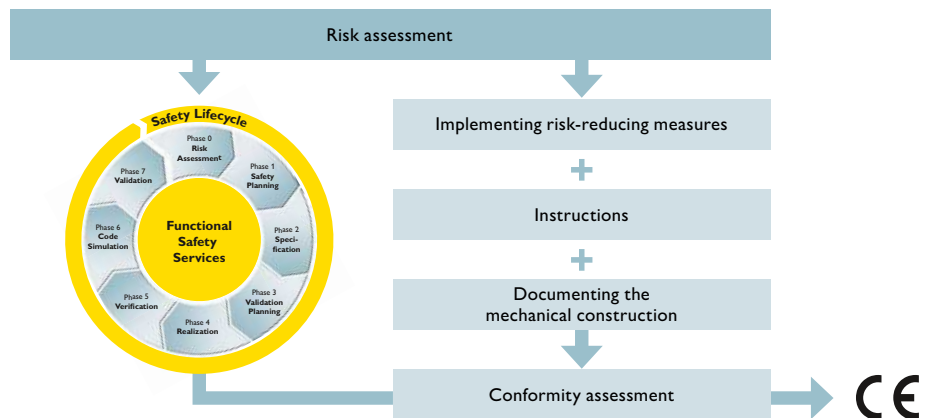

Quality is no coincidence

## Service and support

Implement your automotive industry projects even more quickly and efficiently. Irrespective of whether you operate, plan, produce or maintain systems, Phoenix Contact's services provide professional support that is tailored to your requirements during all phases. This includes an excellent telephone and online service as well as industrial professionals on site. Numerous seminars at Phoenix Contact headquarters or at your company premises are available for training your employees. We always provide expert consultation on all topics related to your products and solutions during after sales.



### Hotline:

- Expert consultation from industry professionals
- Comprehensive support throughout all the phases of your project
- Develop know-how with training courses for your employees



## Service

Do you need customized support? We provide you with the required technical know-how, combined with comprehensive experience across the industry. Together, we determine the services required and support you in choosing the right hardware and software.

## Training and workshops

Thanks to intensive contact with our customers and years of on-site experience, we have developed a qualification concept whereby we can specify employee qualifications in order to meet your individual requirements: we offer you the appropriate service depending on the project phase, target group, and prior knowledge.

## After sales

Our service teams stand out thanks to their focused expertise, years of practical experience, and maximum degree of flexibility.

Our service network is available to you during installation, startup, and operation even in the most remote regions of the world, for example, via a free system hotline with 24 h product support. In the event of an emergency, we can provide you with replacement parts outside of office hours.

Phone: + 49 5281 9-462888

## Local expertise

Phoenix Contact supports you worldwide with professional service and support when it comes to products, services, and solutions.

Depending on requirements, we ensure fast replacement of products or support you in the case of problems by hooking into your system.

Our experts are familiar with the regional conditions and specific challenges of your industry. We are happy to support you all over the world with a tightly-knit network of automation experts. Contact us for more information.

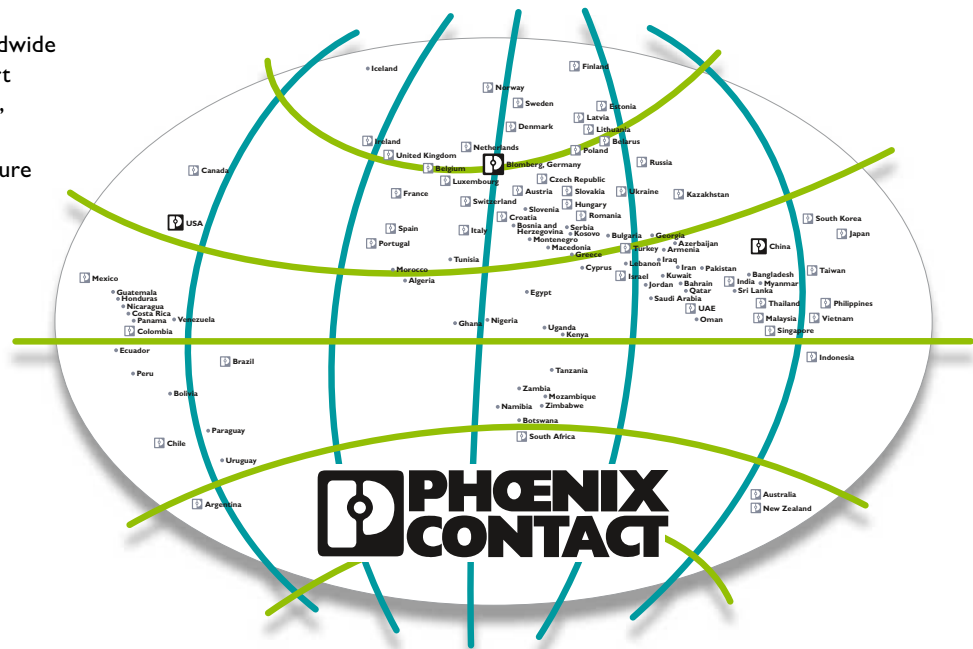

Quality is no coincidence

## Inspiring industry solutions, thanks to excellent products

Phoenix Contact offers innovative products and solutions for all aspects of the Automotive Industry: from the production process, to factory infrastructure, through to E-Mobility. The basis for solutions is the wide range of connection and automation technology. Intelligently combined, these products become systems for a variety of functions such as control, remote monitoring or measuring values. Inspiring industry solutions are created, thanks to industrial expertise, longstanding experience, and consideration of special requirements.



Excellent products

Innovative systems

## Excellent products



### Controllers

Modular small-scale controllers for distributed applications, high-performance system controllers with integrated control of safety of machinery through to redundant control for maximum availability.



### HMIs and industrial PCs

Visualization enables easier navigation and faster responses. Here, we offer scalable industrial PCs and HMIs as well as a visualization wizard for easy operation.



### Industrial Ethernet

Network products to freely shape the infrastructure: unmanaged IP67 switches for decentralization via bandwidth-reserving IRT-capable or modular switches through to routers and WLAN equipment.



### Gateways for PROFI-safe

Cross-system emergency stop and fast, direct process data exchange with our PROFI-safe gateway – and that even occurs on lines with various brands of system control.



### Power supplies

Failsafe power supply solutions from the 24 V/10 A power supply of an auxiliary operating station, to the 40 A supply of a body shop cell, right through to the uninterruptible redundant supply.



### Push-in connection technology

Tool-free and labor-saving wiring with proven terminals, surge protection, fuses, markings, and plug-in bridges as well as the Axioline automation system from Phoenix Contact.



### PN UNI DEVICE plug-in board

PROFINET interface for device and technological suppliers of the Automotive Industry.



### PROFINET technology components

High-performance device interfaces, complex PROFINET controller interfaces, and profiles support you during the implementation of your PROFINET interfaces.



Inspiring  
Industry Solutions

## Passionate about your industry

Each industry places particular demands on system automation. In our dedicated industry teams, we focus on these challenges with technical know-how and passion, and together with our customers we develop tailor-made solutions. Excellent products are at the heart of our

solutions. Cleverly combined to create innovative systems and supplemented by industry-specific features, they ultimately become industry solutions of proven Phoenix Contact quality.



Excellent products



Innovative systems



Inspiring Industry Solutions

[phoenixcontact.com](http://phoenixcontact.com)

PHOENIX CONTACT GmbH & Co. KG  
Flachsmarktstraße 8  
32825 Blomberg, Germany  
Phone: + 49 5235 3-00  
Fax: + 49 5235 3-41200  
E-mail: [info@phoenixcontact.com](mailto:info@phoenixcontact.com)  
[phoenixcontact.com](http://phoenixcontact.com)