

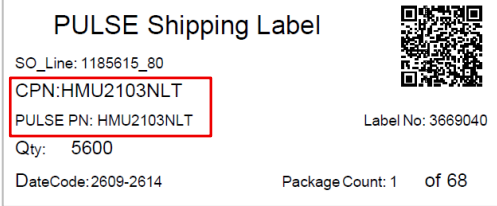

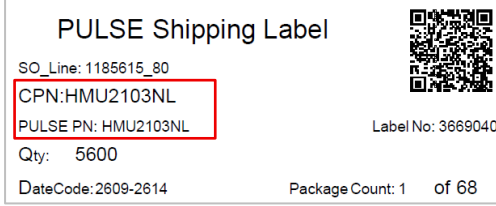















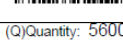









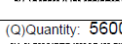









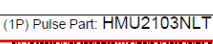
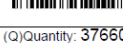



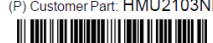

Product Change Notification

PCN Date:	May 21,2025	
Supplier Name:	Pulse Electronics	
Pulse PCN No.	PCN-10000844 Rev. A	
Description of Change	1. Update system to remove "T" from part number for all labels. 2. Remove tube package and only keep tape&reel package.	
Reason for Change	To meet the product customs clearance requirements, all labels and the physical part number should be kept consistent.	
Summary of Changes between the new and old part	Present part	New part
	<p>Inner reel 3s label:</p>  <p>PULSE Shipping Label SO_Line: 1185615_80 CPN:HMU2103NLT PULSE PN: HMU2103NLT Qty: 5600 DateCode:2609-2614 Label No: 3669040 Package Count: 1 of 68</p>	<p>Inner reel 3s label:</p>  <p>PULSE Shipping Label SO_Line: 1185615_80 CPN:HMU2103NL PULSE PN: HMU2103NL Qty: 5600 DateCode:2609-2614 Label No: 3669040 Package Count: 1 of 68</p>
	<p>P2 label</p>  <p>(P)Customer Part: HMU2103NLT (IP)Manufacturer Part: HMU2103NLT (Q)Quantity: 700 (4L)COO: CN (10D)Date Code: 2614 China 3020 (1T)LOT Code: 2614 Pulse RoHS</p>	<p>P2 label</p>  <p>(P)Customer Part: HMU2103NL (IP)Manufacturer Part: HMU2103NL (Q)Quantity: 700 (4L)COO: CN (10D)Date Code: 2614 China 3020 (1T)LOT Code: 2614 Pulse RoHS</p>
	<p>Carton label:</p>  <p>PULSE P/N: HMU2103NLT Desc: XFMR-CMC,SGL,4.3KVDC,SM,OH NPB WO: 2420006 Qty: 5600 Unit: EA Date Code: 2614 Exp. Date: 03/30/2029 HU No.: 5003017816 Batch No: P7P1350009 COO: China</p>	<p>Carton Label:</p>  <p>PULSE P/N: HMU2103NL Desc: XFMR-CMC,SGL,4.3KVDC,SM,OH NPB WO: 2420006 Qty: 5600 Unit: EA Date Code: 2614 Exp. Date: 03/30/2029 HU No.: 5003017816 Batch No: P7P1350009 COO: China</p>
	3S label:	3S label:

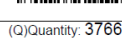
	<p>FR: Mianyang Pulse Electronics LTD Export Process Zone High-Tech Industrial Development Zone MianYang Sichuan 621000 CN</p> <p>TO: AVNET TECHNOLOGY HONG KONG LTD GATE 1A, EAST WING, 1/F, CHINA RESOURCES INTERNATIONAL LOGISTICS CENTRE, NO. 2 TAT MEI ROAD, KWAI CHUNG NT HK</p> <p>1 1008704</p> <p>(3S) PKG ID: PULSE+3669040 Ship Date: 20260410</p>  <p>(K) Cust Po: 6209969305 (4K)Cust Po Line:20</p>   <p>(P) Customer Part: HMU2103NLT (4L)COO:CN</p>   <p>(1P) Pulse Part: HMU2103NLT</p>  <p>(Q)Quantity: 5600</p>  <p>(10D)Date Code: 2609-2614</p>   <p>(1T) Lot Code: 2609-2614 SO Line:0001185615000080</p>   <p>Page Count: 1 Of 68 Package Weight: 11.7 LB 5.3 KG</p>	<p>FR: Mianyang Pulse Electronics LTD Export Process Zone High-Tech Industrial Development Zone MianYang Sichuan 621000 CN</p> <p>TO: AVNET TECHNOLOGY HONG KONG LTD GATE 1A, EAST WING, 1/F, CHINA RESOURCES INTERNATIONAL LOGISTICS CENTRE, NO. 2 TAT MEI ROAD, KWAI CHUNG NT HK</p> <p>1 1008704</p> <p>(3S) PKG ID: PULSE+3669040 Ship Date: 20260410</p>  <p>(K) Cust Po: 6209969305 (4K)Cust Po Line:20</p>   <p>(P) Customer Part: HMU2103NLT (4L)COO:CN</p>   <p>(1P) Pulse Part: HMU2103NLT</p>  <p>(Q)Quantity: 5600</p>  <p>(10D)Date Code: 2609-2614</p>   <p>(1T) Lot Code: 2609-2614 SO Line:0001185615000080</p>   <p>Page Count: 1 Of 68 Package Weight: 11.7 LB 5.3 KG</p>
	<p>4S label:</p> <p>FR: Mianyang Pulse Electronics LTD Export Process Zone High-Tech Industrial Development Zone MianYang Sichuan 621000 CN</p> <p>TO: AVNET TECHNOLOGY HONG KONG LTD GATE 1A, EAST WING, 1/F, CHINA RESOURCES INTERNATIONAL LOGISTICS CENTRE, NO. 2 TAT MEI ROAD, KWAI CHUNG NT HK</p> <p>1 1008704</p> <p>(4S) PKG ID: PULSE+3669039 Ship Date: 20260410</p>  <p>(K) Cust Po: 6209969305 (4K)Cust Po Line:20</p>   <p>(P) Customer Part: HMU2103NLT (4L)COO:CN</p>   <p>(1P) Pulse Part: HMU2103NLT</p>  <p>(Q)Quantity: 376600</p>  <p>(10D)Date Code: 2609-2614</p>   <p>(1T) Lot Code: 2609-2614 SO Line:0001185615000080</p>   <p>Page Count: 68 Package Weight: 794.1 LB 360.2 KG</p>	<p>4S label:</p> <p>FR: Mianyang Pulse Electronics LTD Export Process Zone High-Tech Industrial Development Zone MianYang Sichuan 621000 CN</p> <p>TO: AVNET TECHNOLOGY HONG KONG LTD GATE 1A, EAST WING, 1/F, CHINA RESOURCES INTERNATIONAL LOGISTICS CENTRE, NO. 2 TAT MEI ROAD, KWAI CHUNG NT HK</p> <p>1 1008704</p> <p>(4S) PKG ID: PULSE+3669039 Ship Date: 20260410</p>  <p>(K) Cust Po: 6209969305 (4K)Cust Po Line:20</p>   <p>(P) Customer Part: HMU2103NLT (4L)COO:CN</p>   <p>(1P) Pulse Part: HMU2103NLT</p>  <p>(Q)Quantity: 376600</p>  <p>(10D)Date Code: 2609-2614</p>   <p>(1T) Lot Code: 2609-2614 SO Line:0001185615000080</p>   <p>Page Count: 68 Package Weight: 794.1 LB 360.2 KG</p>
<p>Traceability guidelines</p>	<p>By production Date (YYWK) Note: The traceability record can be provided upon request.</p>	
<p>Qualification Data attached? File name(s)</p>	<p>Not applicable. No impact.</p>	

Customer	Customer Part Number	Pulse Part Number	PCN Effectivity Date
Refer to the attached PN and customer list		HMU2103NL/T HM2179NL/T HM1238NL/T HM2202NL/T	Immediately

Customer: Generic

Originator: Grace

Phone: (86)-0816-7077888-6012

E-mail: Grace.yang@yageo.com

Statement: Dear customer, please response this PCN requirement. If you have any special requirements, please let us know. Lack of response after 30 days will be considered acceptable of change.



NOTES:

1. ROHS COMPLIANT
2. STORAGE TEMPERATURE: -50°C TO +150°C
3. COMPLIANCE TO J-STD:
 - A. J-STD-002: SOLDERABILITY AT 245°C
 - B. J-STD-020: MSL 1, 245°C MAXIMUM REFLOW
 - C. J-STD-075: R7, CLASSIFICATION TEMP AT 245°C

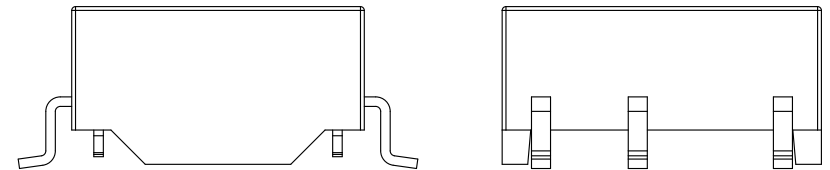
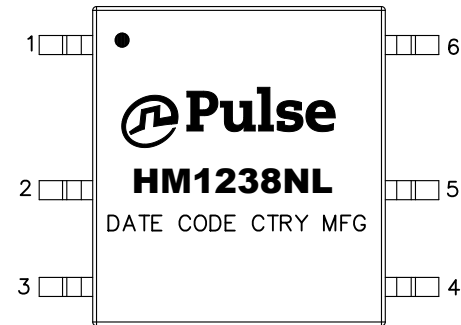

FINAL OUTLINE

PRODUCT DESCRIPTION	TLA DRAWING	PS DRAWING	SHEET	PART NO.	DATASHEET REV.
TRANSFORMER/CMC,4.3KVDC ISO,SGL,SM	HM1238NL-12	PS-01804.001-B	1 OF 5	HM1238NL	K

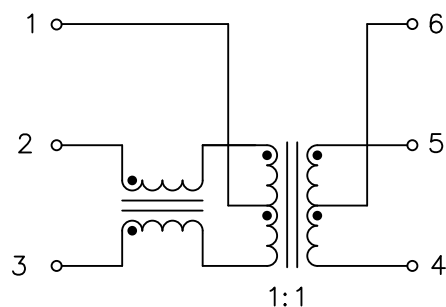

SCHEMATIC

ELECTRICAL CHARACTERISTICS AT +25°C UNLESS OTHERWISE SPECIFIED
(FOR REFERENCE ONLY. USED FOR CUSTOMER INFORMATION.)

PARAMETER	SPECIFICATIONS
QUALIFICATION	PER AEC-Q200
OPERATING TEMP	-40°C TO +150°C
TURNS RATIO	1 : 1 ±2%
POLARITY	PER SCHEMATIC
▽ LL	AT 100 KHz, 1 VRMS (2-3) = 0.5 uH MAXIMUM, SHORT (6-4-5)
INDUCTANCE (OCL) AT 100 kHz, 100 mV (-40°C TO +125°C)	300 uH MIN
DCR	(1-3) = (1-2) = 0.5 OHMS MAX
	(4-6) = (5-6) = 0.4 OHMS MAX
▼ INPUT - OUTPUT ISOLATION	4300 VDC FOR 60 SECONDS
WORKING VOLTAGE	1000 VDC

NOTE: "▽" IS SPECIAL CHARACTERISTIC.

PRODUCT DESCRIPTION	TLA DRAWING	PS DRAWING	SHEET	PART NO.	DATASHEET REV.
TRANSFORMER/CMC,4.3KVDC ISO,SGL,SM	HM1238NL-12	PS-01804.001-B	2 OF 5	HM1238NL	K

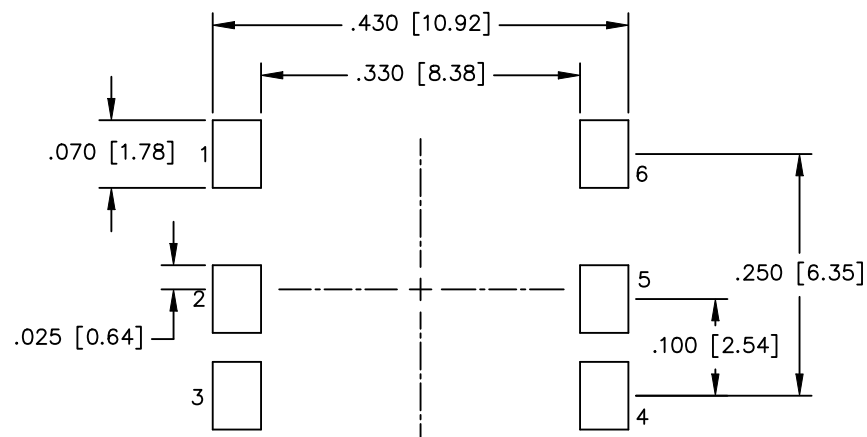
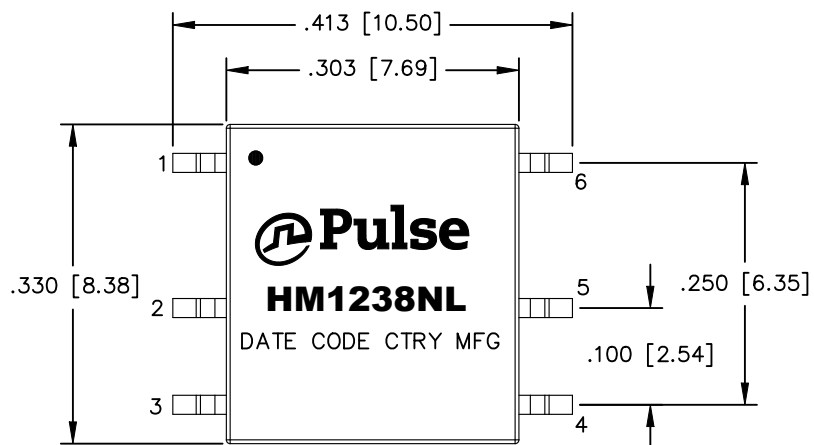

SUGGESTED LAND PATTERN

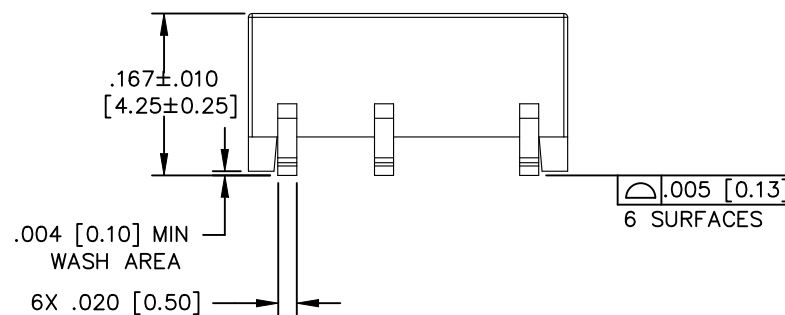
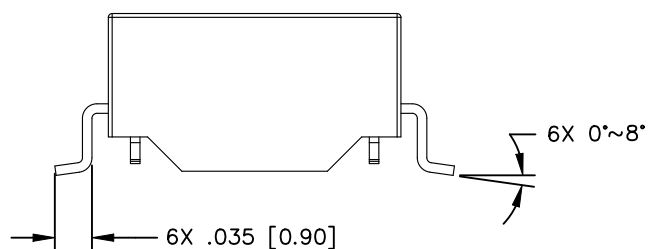

DIMENSIONS ARE IN INCHES [MILLIMETERS] WITH THE FOLLOWING TOLERANCES: [MILLIMETERS] ARE FOR REFERENCE ONLY.
 .XX= ±.01 [±0.25]
 .XXX= ±.005 [±0.13]

© Copyright, 2026. Pulse Electronics Corp. All rights reserved. Pulse confidential & proprietary. (05/26/26)

PRODUCT DESCRIPTION	TLA DRAWING	PS DRAWING	SHEET	PART NO.	DATASHEET REV.
TRANSFORMER/CMC,4.3KVDC ISO,SGL,SM	HM1238NL-12	PS-01804.001-B	3 OF 5	HM1238NL	K

PACKING SPECIFICATION:

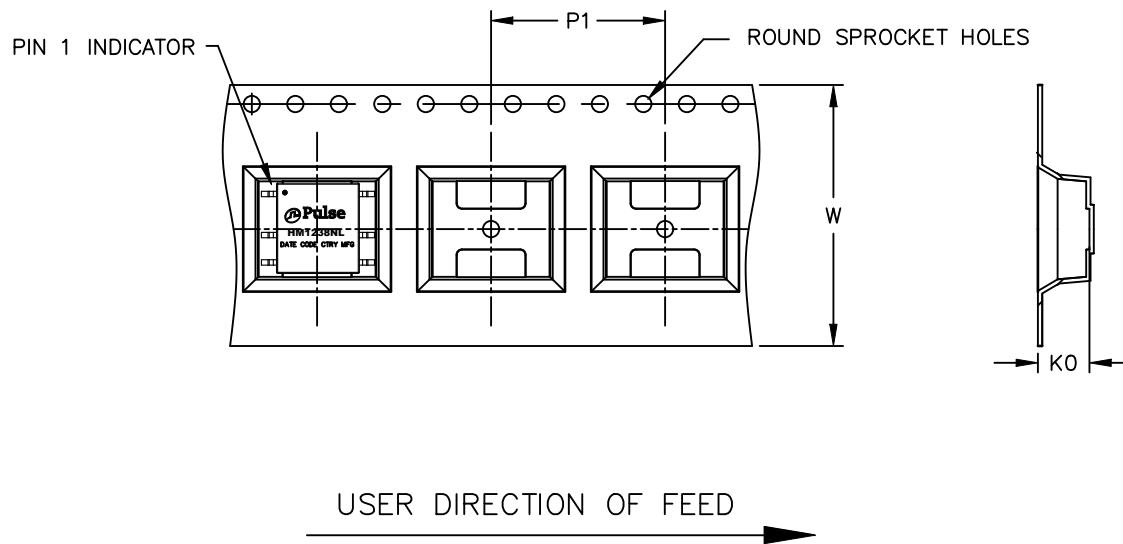

TAPE & REEL INFORMATION		
ITEMS	DATA	UNIT
WIDTH (W)	24.0	MM
PITCH (P1)	16.0	MM
DEPTH (K0)	4.74	MM

ALL DIMENSIONS ARE IN MM.

PRODUCT DESCRIPTION	TLA DRAWING	PS DRAWING	SHEET	PART NO.	DATASHEET REV.
TRANSFORMER/CMC,4.3KVDC ISO,SGL,SM	HM1238NL-12	PS-01804.001-B	4 OF 5	HM1238NL	K



CHANGE RECORD

REV	DESCRIPTION	DATE	APPROVED
G	—	17MAY18	BEZHOU
H	ADD PIN POSITION	15AUG22	BEZHOU
I	ADD PACKING	12MAR24	BEZHOU
J	CUSTOMER FINDINGS FROM ZOLLNER	28MAR24	JZHAO
K	REMOVE NOTES : "TO ORDER TAPE & REEL PACKAGING ADD A "T" SUFFIX" ON PAGE 1	26MAY26	BEZHOU

PRODUCT DESCRIPTION	TLA DRAWING	PS DRAWING	SHEET	PART NO.	DATASHEET REV.
TRANSFORMER/CMC,4.3KVDC ISO,SGL,SM	HM1238NL-12	PS-01804.001-B	5 OF 5	HM1238NL	K



NOTES:

1. ROHS COMPLIANT
2. STORAGE TEMPERATURE: -50°C TO +125°C
3. COMPLIANCE TO J-STD:
 - A. J-STD-002: SOLDERABILITY AT 245°C REFLOW PROFILE
 - B. J-STD-020: MOISTURE SENSITIVE LEVEL 1
 - C. J-STD-075: R7, 245°C MAXIMUM THROUGH REFLOW SOLDER

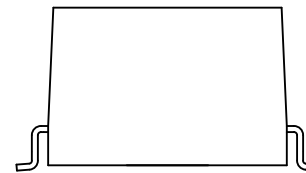
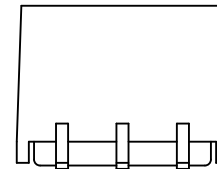
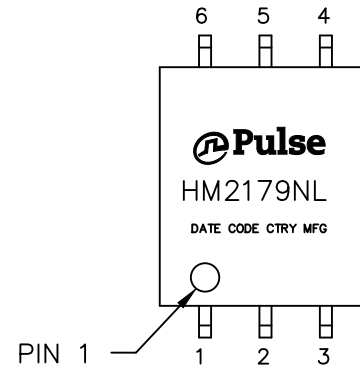

FINAL OUTLINE

PRODUCT DESCRIPTION	TLA DRAWING	PS DRAWING	SHEET	PART NO.	DATASHEET REV.
TRANSFORMER/CMC,4.3KVDC ISO,SGL,SMT	HM2179NL-11	PS-2431.001-B	1 OF 5	HM2179NL	B



ELECTRICAL CHARACTERISTICS AT +25°C UNLESS OTHER SPECIFIED

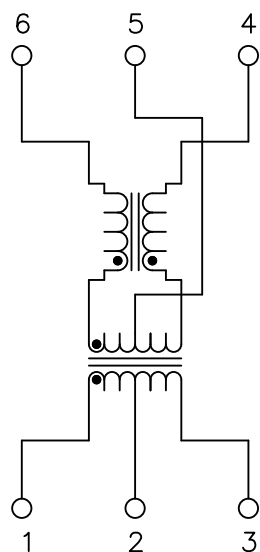

SCHEMATIC

PARAMETER	SPECIFICATIONS	
QUALIFICATION	PER AEC-Q200	
DESIGN CONSTRUCTION	FUNCTIONAL INSULATION	
OPERATING TEMPERATURE	-40°C TO +125°C	
TURNS RATIO	1.00 ± 2%	
POLARITY	PER SCHEMATIC	
DC RESISTANCE	TRANSFORMER SIDE	CM CHOKE SIDE
	0.45 OHMS MAX	0.85 OHMS MAX
▽ INDUCTANCE (OCL) AT 100 kHz, 100 mV (-40°C TO +125°C)	60 uH MIN	
LEAKAGE INDUCTANCE	0.50 uH MAX @ 100 kHz, 100mVRMS	
INSERTION LOSS	0.30 dB MAX @ 4 MHz	
RETURN LOSS (Z OUT = 100 OHM ±1%)	20 dB MIN @ 4 MHz	
COMMON MODE REJECTION RATIO	1-10 MHz	10-1000 MHz
	-35 dB TYP	-20 dB TYP
▼ INPUT - OUTPUT ISOLATION	4300 VDC FOR 60 SECONDS WITH 1.0 mA MAX OF LEAKAGE CURRENT	
INSULATION RESISTANCE	400 MEGAOHMS MINIMUM	
WORKING VOLTAGE	800 VDC FOR 15 YEARS	

NOTE: 1. "▽" IS SPECIAL CHARACTERISTIC.

PRODUCT DESCRIPTION	TLA DRAWING	PS DRAWING	SHEET	PART NO.	DATASHEET REV.
TRANSFORMER/CMC,4.3KVDC ISO,SGL,SMT	HM2179NL-11	PS-2431.001-B	2 OF 5	HM2179NL	B

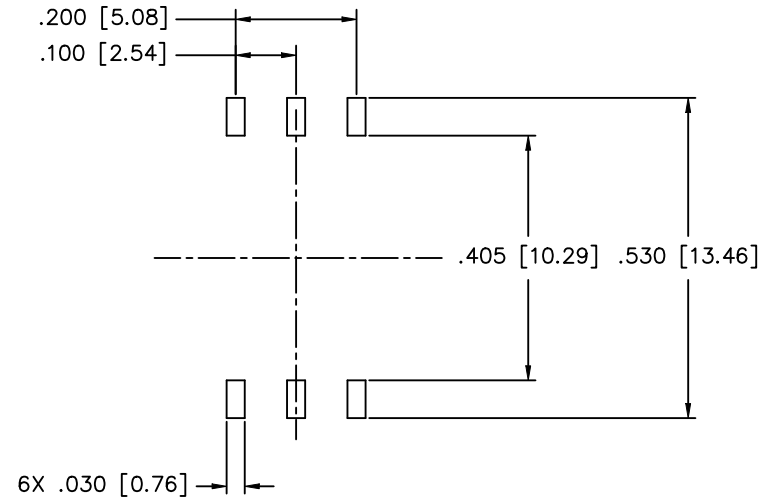
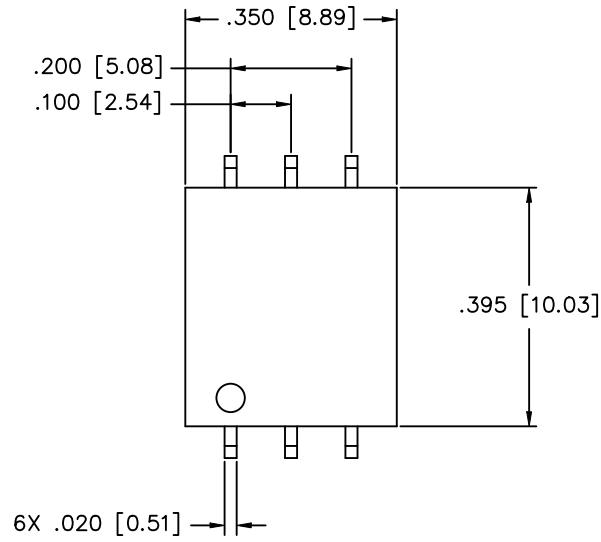

SUGGESTED LAND PATTERN

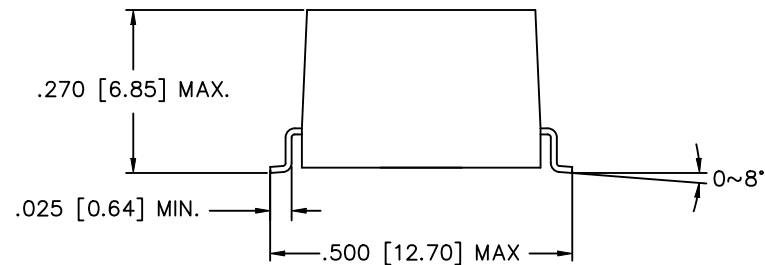
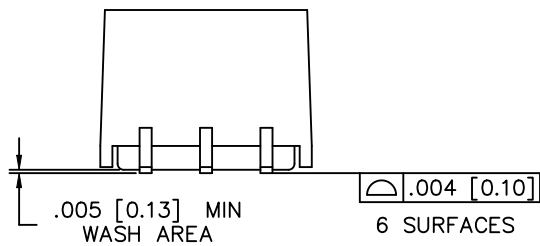

DIMENSIONS ARE IN INCHES [MILLIMETERS] WITH THE FOLLOWING TOLERANCES: [MILLIMETERS] ARE FOR REFERENCE ONLY.
 .XX= ±.01 [±0.25]
 .XXX= ±.005 [±0.13]

PRODUCT DESCRIPTION	TLA DRAWING	PS DRAWING	SHEET	PART NO.	DATASHEET REV.
TRANSFORMER/CMC,4.3KVDC ISO,SGL,SMT	HM2179NL-11	PS-2431.001-B	3 OF 5	HM2179NL	B



USER DIRECTION OF FEED
→

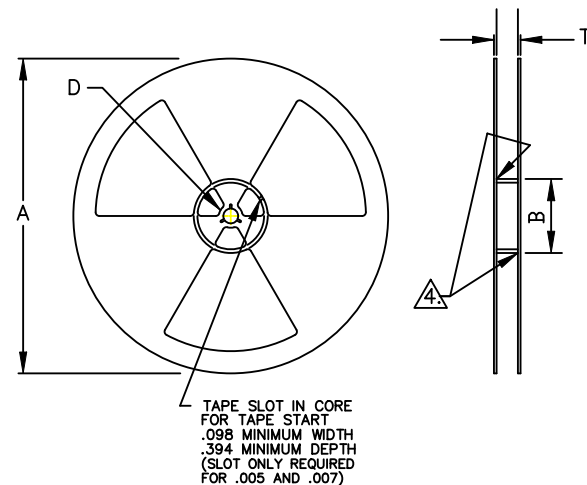
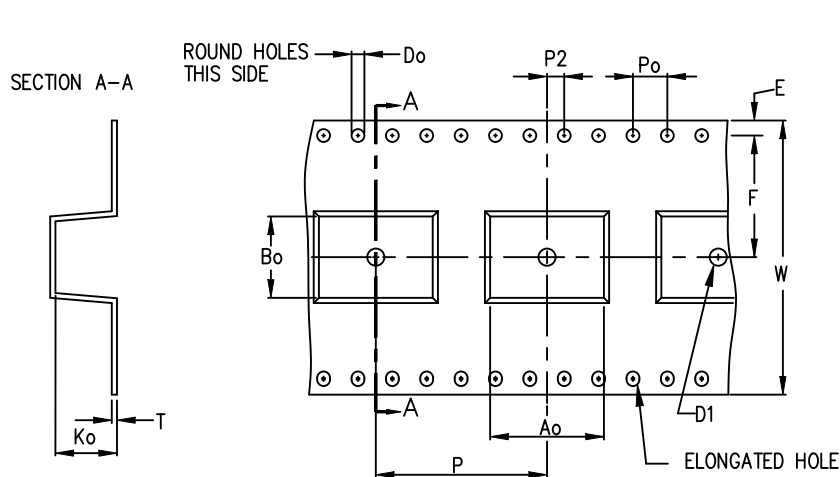

ITEM	W	Ao	Bo	Ko	K1	P	F	E	Do	D1	Po	P2	T
DIM	32.00 ±0.30	13.3 ±0.10	9.5 ±0.10	9.5 ±0.10		20.00 ±0.10	14.2 ±0.10	1.75 ±0.10	1.50 +0.10 -0.00	2.0 +0.10 -0.00	4.00 ±0.10	2.00 ±0.10	0.50 ±0.05

	A	B	D	T	G	G
Tolerance		min.	min.	max.	min.	max.
Tape width mm	330.00	100.00	20.20	38.4	32.4	34.4

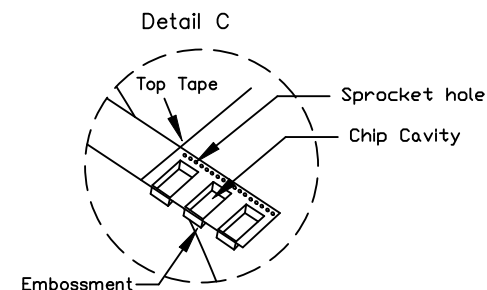
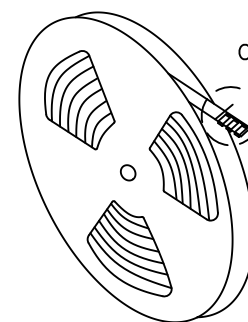
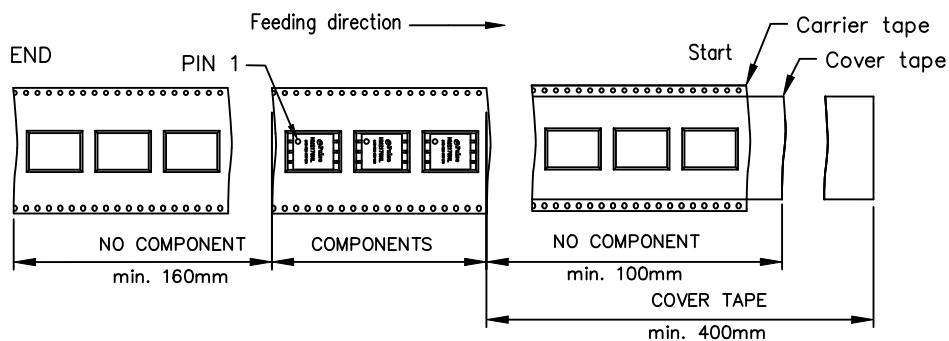

DIMENSIONS ARE IN MILLIMETERS WITH THE FOLLOWING TOLERANCES:
.XX= ±0.10

© Copyright, 2026, Pulse Electronics Corp. All rights reserved. Pulse confidential & proprietary. (05/26/26)

PRODUCT DESCRIPTION	TLA DRAWING	PS DRAWING	SHEET	PART NO.	DATASHEET REV.
TRANSFORMER/CMC,4.3KVDC ISO,SGL,SMT	HM2179NL-11	PS-2431.001-B	4 OF 5	HM2179NL	B



CHANGE RECORD

REV	DESCRIPTION	DATE	APPROVED
A	NEW DS	30AUG21	TIMLIN
B	REMOVE NOTES : "TO ORDER TAPE & REEL PACKAGING ADD A "T" SUFFIX" ON PAGE 1	26MAY26	BEZHOU

PRODUCT DESCRIPTION	TLA DRAWING	PS DRAWING	SHEET	PART NO.	DATASHEET REV.
TRANSFORMER/CMC,4.3KVDC ISO,SGL,SMT	HM2179NL-11	PS-2431.001-B	5 OF 5	HM2179NL	B



NOTES:

1. ROHS COMPLIANT
2. STORAGE TEMPERATURE: -50°C TO +125°C
3. COMPLIANCE TO J-STD:
 - A. J-STD-002: SOLDERABILITY AT 245°C REFLOW PROFILE
 - B. J-STD-020: MOISTURE SENSITIVE LEVEL 1
 - C. J-STD-075: R7, 245°C MAXIMUM THROUGH REFLOW SOLDER

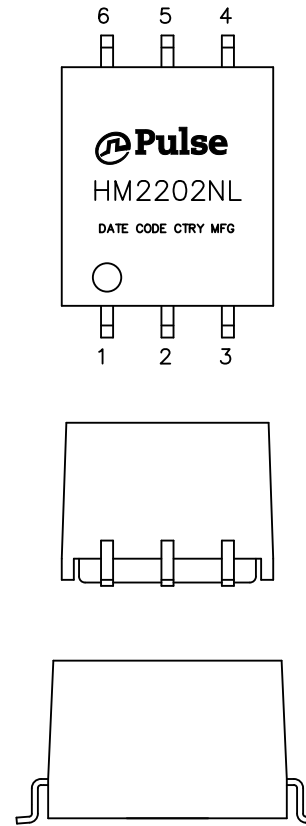

PRODUCT DESCRIPTION	TLA DRAWING	PS DRAWING	SHEET	PART NO.	DATASHEET REV.
TRANSFORMER,5.6KVDC ISO,SGL,SMT	HM2202NL-11	PS-2431.001-B	1 OF 5	HM2202NL	D

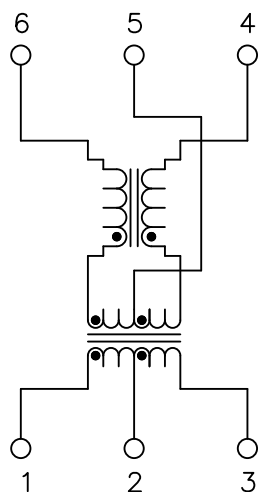

SCHEMATIC

ELECTRICAL CHARACTERISTICS AT +25°C UNLESS OTHER SPECIFIED
(FOR REFERENCE ONLY. USED FOR CUSTOMER INFORMATION.)

PARAMETER	SPECIFICATIONS	
QUALIFICATION	PER AEC-Q200	
DESIGN CONSTRUCTION	FUNCTIONAL INSULATION	
CREEPAGE DISTANCE	> 5mm	
OPERATING TEMPERATURE	-40°C TO +125°C	
TURNS RATIO	1.00 ± 2%	
POLARITY	PER SCHEMATIC	
DC RESISTANCE	TRANSFORMER SIDE	CM CHOKE SIDE
	0.60 OHMS MAX	1.20 OHMS MAX
▽ INDUCTANCE (OCL) AT 100 kHz, 100 mV (-40°C TO +125°C)	150 uH MIN, 450 uH MAX	
LEAKAGE INDUCTANCE	0.50 uH MAX @ 100 kHz	
INSERTION LOSS	0.25 dB MAX @ 4 MHz	
RETURN LOSS (Z OUT = 100 OHM ±1%)	20 dB MIN @ 4 MHz	
COMMON MODE REJECTION RATIO	1-10 MHz	10-1000 MHz
	-35 dB MIN	-20 dB MIN
▼ INPUT - OUTPUT ISOLATION	5600 VDC FOR 60 SECONDS WITH 1.0 mA MAX OF LEAKAGE CURRENT	
INSULATION RESISTANCE	400 MEGAOHMS MINIMUM	
WORKING VOLTAGE	1200 VDC FOR 15 YEARS	

NOTE: "▽" IS SPECIAL CHARACTERISTIC.

PRODUCT DESCRIPTION	TLA DRAWING	PS DRAWING	SHEET	PART NO.	DATASHEET REV.
TRANSFORMER, 5.6KVDC ISO, SGL, SMT	HM2202NL-11	PS-2431.001-B	2 OF 5	HM2202NL	D

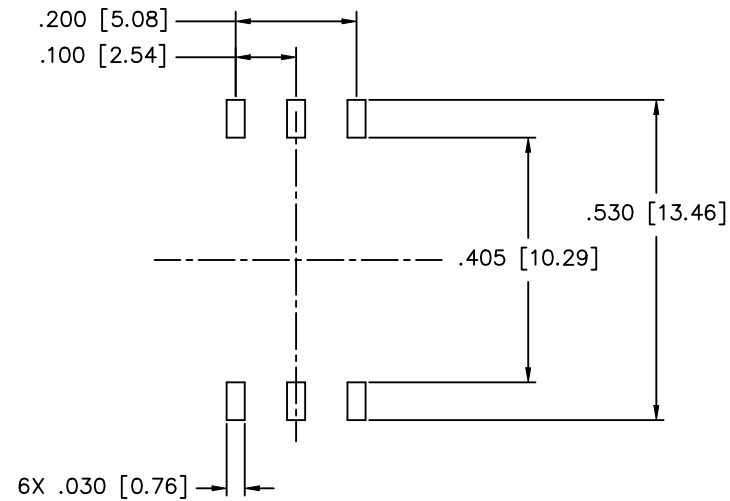
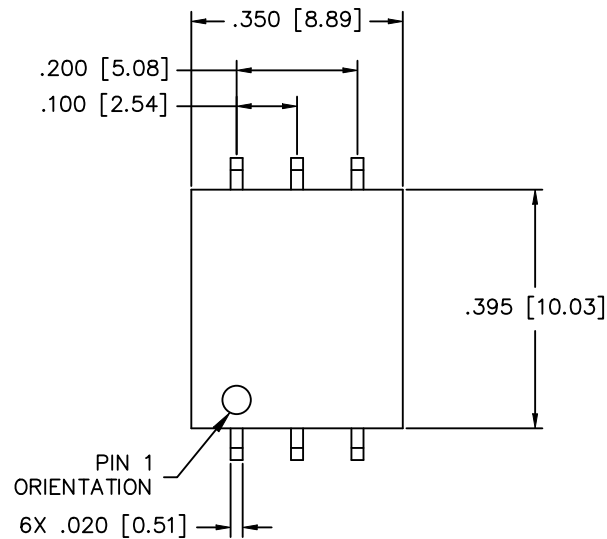

SUGGESTED LAND PATTERN

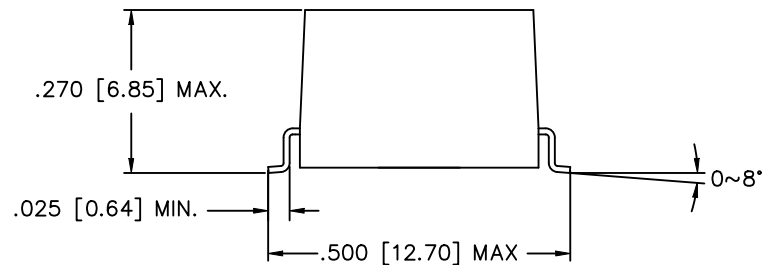
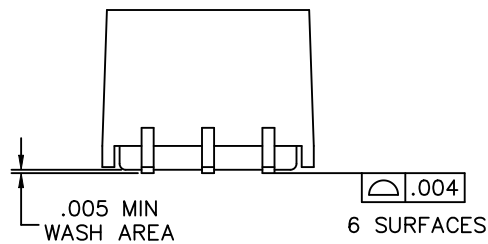

DIMENSIONS ARE IN INCHES [MILLIMETERS] WITH THE FOLLOWING TOLERANCES: [MILLIMETERS] ARE FOR REFERENCE ONLY.
 .XX= ±.01 [±0.25]
 .XXX= ±.005 [±0.13]

© Copyright, 2026. Pulse Electronics Corp. All rights reserved. Pulse confidential & proprietary. (05/26/26)

PRODUCT DESCRIPTION	TLA DRAWING	PS DRAWING	SHEET	PART NO.	DATASHEET REV.
TRANSFORMER,5.6KVDC ISO,SGL,SMT	HM2202NL-11	PS-2431.001-B	3 OF 5	HM2202NL	D

USER DIRECTION OF FEED
→

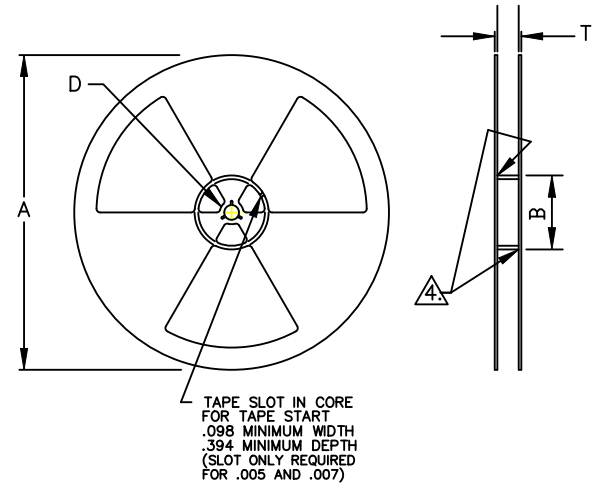
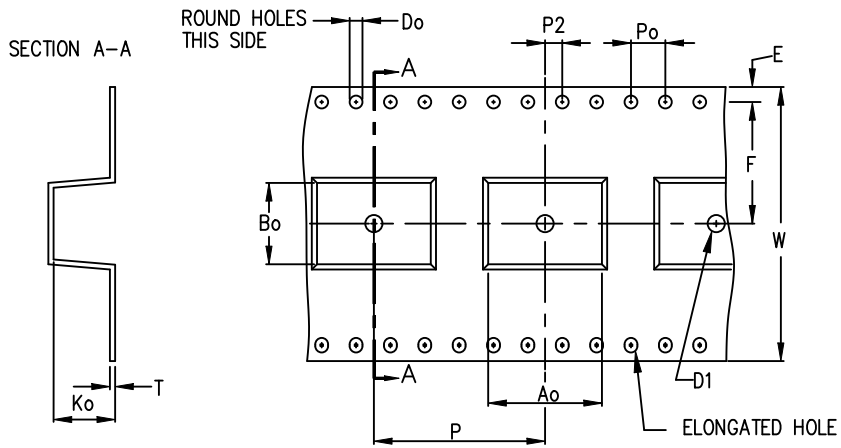

ITEM	W	Ao	Bo	Ko	K1	P	F	E	Do	D1	Po	P2	T
DIM	32.00 ±0.30	13.3 ±0.10	9.5 ±0.10	9.5 ±0.10		20.00 ±0.10	14.2 ±0.10	1.75 ±0.10	1.50 +0.10 -0.00	2.0 +0.10 -0.00	4.00 ±0.10	2.00 ±0.10	0.50 ±0.05

	A	B	D	T	G	G
Tolerance		min.	min.	max.	min.	max.
Tape width mm	330.00	100.00	20.20	38.4	32.4	34.4

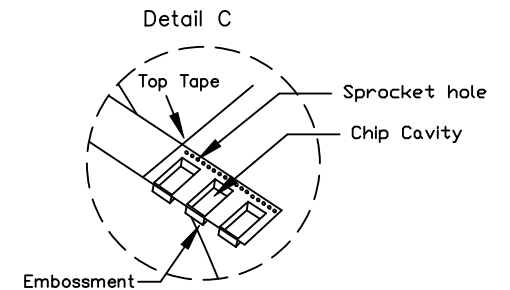
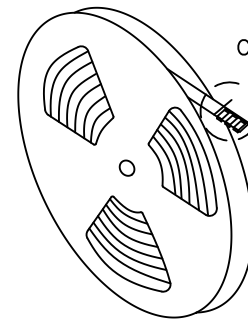
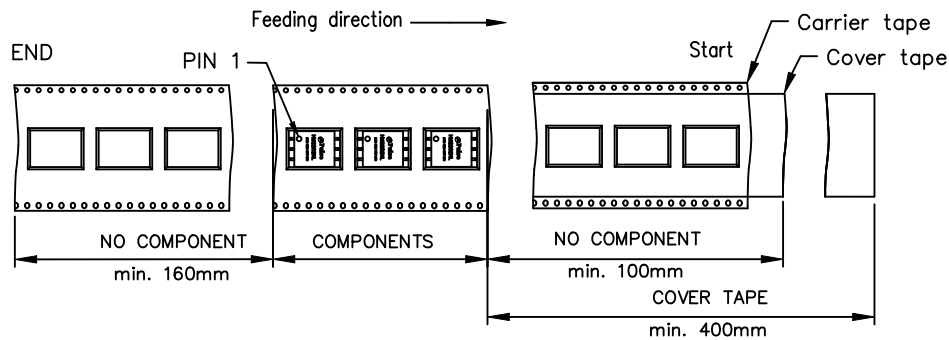

DIMENSIONS ARE IN MILLIMETERS WITH THE FOLLOWING TOLERANCES:
.XX= ±0.10

© Copyright, 2026. Pulse Electronics Corp. All rights reserved. Pulse confidential & proprietary. (05/26/26)

PRODUCT DESCRIPTION	TLA DRAWING	PS DRAWING	SHEET	PART NO.	DATASHEET REV.
TRANSFORMER,5.6KVDC ISO,SGL,SMT	HM2202NL-11	PS-2431.001-B	4 OF 5	HM2202NL	D



CHANGE RECORD

REV	DESCRIPTION	DATE	AUTHOR
A	NEW DS	18JUL22	BEZHOU
B	REMOVE PENDING OF AEC-Q200 AND "PRELIMINARY" OF WATERMARK BACKGROUND	30NOV23	STANYIN
C	CHANGE WORKING VOLTAGE FROM 1000 VDC TO 1200 VDC	04JAN24	BEZHOU
D	REMOVE NOTES : "TO ORDER TAPE & REEL PACKAGING ADD A "T" SUFFIX" ON PAGE 1	26MAY26	BEZHOU

PRODUCT DESCRIPTION	TLA DRAWING	PS DRAWING	SHEET	PART NO.	DATASHEET REV.
TRANSFORMER,5.6KVDC ISO,SGL,SMT	HM2202NL-11	PS-2431.001-B	5 OF 5	HM2202NL	D



NOTES:

1. ROHS COMPLIANT
2. STORAGE TEMPERATURE: -50°C TO +125°C
3. COMPLIANCE TO J-STD:
 - A. J-STD-002: SOLDERABILITY AT 245°C REFLOW PROFILE
 - B. J-STD-020: MOISTURE SENSITIVE LEVEL 1
 - C. J-STD-075: R7, 245°C MAXIMUM THROUGH REFLOW SOLDER

4. PACKING SPECIFICATION:
 REEL SIZE: 330mm
 TAPE WIDTH: 16mm
 TAPE PITCH: 12mm

COMPONENTS PER REEL: 700 pcs

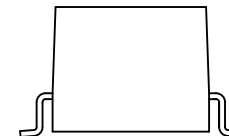
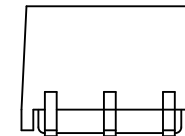
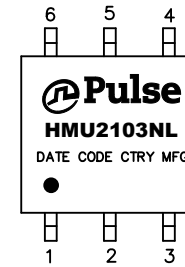

FINAL OUTLINE

PRODUCT DESCRIPTION	TLA DRAWING	PS DRAWING	SHEET	PART NO.	DATASHEET REV.
TRANSFORMER/CMC,4.3kVDC ISO,SGL,SMT	HMU2103NL-14	PS-2303.002-A	1 OF 5	HMU2103NL	I



ELECTRICAL CHARACTERISTICS AT +25°C UNLESS OTHER SPECIFIED
(FOR REFERENCE ONLY. USED FOR CUSTOMER INFORMATION.)

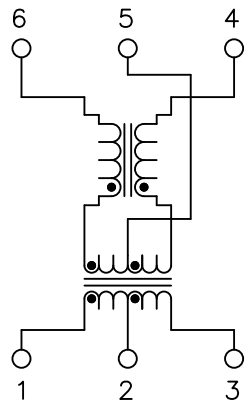

SCHEMATIC

PARAMETER	SPECIFICATIONS	
QUALIFICATION	PER AEC-Q200	
OPERATING TEMPERATURE	-40°C TO +125°C	
TURNS RATIO	1.00 ± 2%	
POLARITY	PER SCHEMATIC	
DC RESISTANCE	TRANSFORMER SIDE	CM CHOKE SIDE
	0.35 OHMS MAX	0.80 OHMS MAX
▽ INDUCTANCE (OCL) AT 100 kHz, 100 mV (-40°C TO +125°C)	150 uH MIN, 370 uH MAX	
▽ INSERTION LOSS	0.30 dB MAX @ 4 MHz	
LEAKAGE INDUCTANCE	0.5uH MAX @ 100 kHz	
RETURN LOSS (Z OUT = 100 OHM ±15%)	20 dB MIN @ 4 MHz	
COMMON MODE REJECTION RATIO	1 - 10 MHz	10-1000 MHz
	-35 dB MIN	-20 dB MIN
▼ INPUT - OUTPUT ISOLATION	4300 VDC FOR 60 SECONDS	
WORKING VOLTAGE	1000 VDC FOR 15 YEARS	
CREEPAGE DISTANCE	> 5mm	

NOTE: "▽" IS SPECIAL CHARACTERISTIC.

PRODUCT DESCRIPTION	TLA DRAWING	PS DRAWING	SHEET	PART NO.	DATASHEET REV.
TRANSFORMER/CMC,4.3kVDC ISO,SGL,SMT	HMU2103NL-14	PS-2303.002-A	2 OF 5	HMU2103NL	I

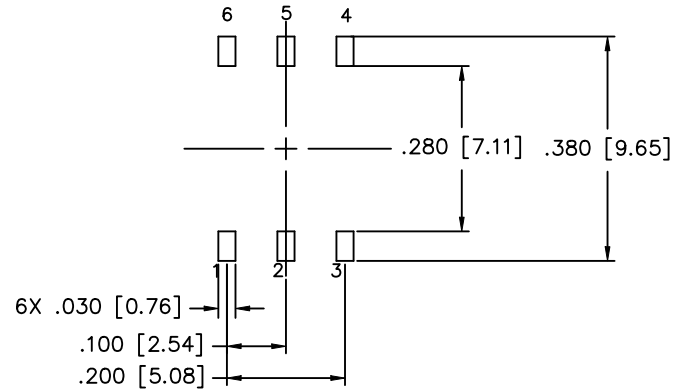
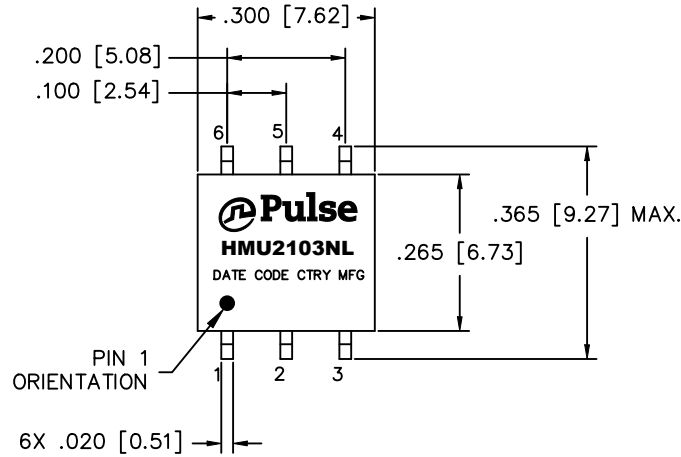

SUGGESTED LAND PATTERN

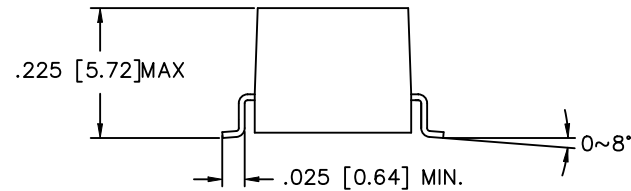
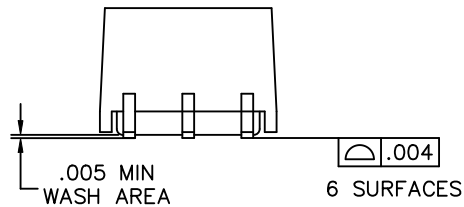

DIMENSIONS ARE IN INCHES [MILLIMETERS] WITH THE FOLLOWING TOLERANCES: [MILLIMETERS] ARE FOR REFERENCE ONLY.
 .XX= ± 0.01 [± 0.25]
 .XXX= ± 0.005 [± 0.13]

© Copyright, 2026. Pulse Electronics Corp. All rights reserved. Pulse confidential & proprietary. (05/26/26)

PRODUCT DESCRIPTION	TLA DRAWING	PS DRAWING	SHEET	PART NO.	DATASHEET REV.
TRANSFORMER/CMC,4.3kVDC ISO,SGL,SMT	HMU2103NL-14	PS-2303.002-A	3 OF 5	HMU2103NL	I



USER DIRECTION OF FEED →

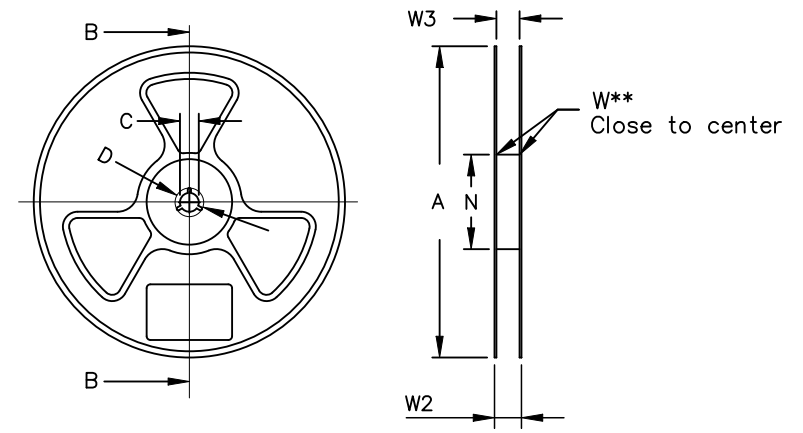
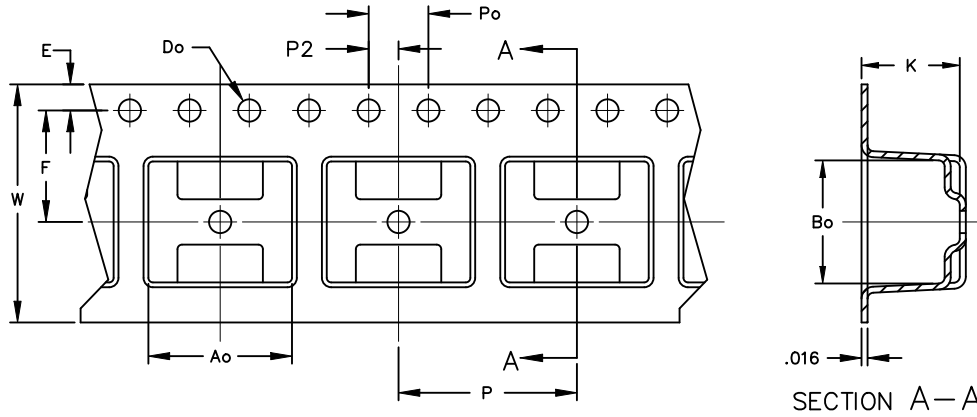

ITEM	W	P	Ao	Bo	K	T	C	Do	E	F	Po
DIM	16	12	9.65	8.28	6.6	0.40		1.5	1.75	7.5	4.0

	A	B	C	D	N	W1	W2	W3	W3
Tolerance		min.	±0.8	min.	min.	+2.0	max.	min.	max.
Tape width/mm	330.00	1.50	13.00	20.20	100.00	16.4	18.4	16.4	18.39

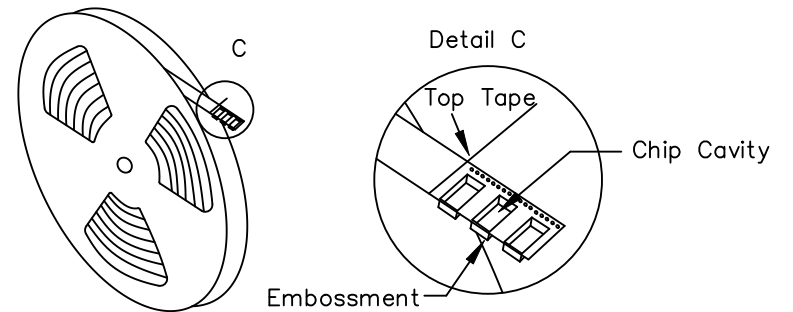
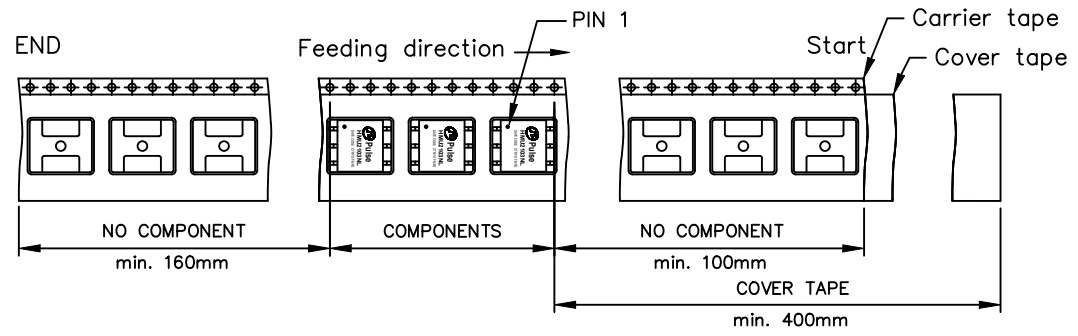

ALL DIMENSIONS ARE IN MILLIMETERS WITH THE FOLLOWING TOLERANCES: ±0.10

© Copyright, 2026. Pulse Electronics Corp. All rights reserved. Pulse confidential & proprietary. (05/26/26)

PRODUCT DESCRIPTION	TLA DRAWING	PS DRAWING	SHEET	PART NO.	DATASHEET REV.
TRANSFORMER/CMC,4.3kVDC ISO,SGL,SMT	HMU2103NL-14	PS-2303.002-A	4 OF 5	HMU2103NL	I



CHANGE RECORD

REV	DESCRIPTION	DATE	APPROVED
A	NEW DS	-	BEZHOU
B	CHANGE OCL FROM 170 uH MIN, 350 uH MAX TO 150 uH MIN, 370 uH MAX	-	BEZHOU
C	CHANGE QUALIFICATION FROM AEC-Q200 (PENDING) TO PER AEC-Q200	-	BEZHOU
D	CHANGE NEW "ROHS" AND "AEC-Q200" LOGO	-	BEZHOU
E	ADD SC WITH "▽" AND PACKING INFORMATION	01SEP17	BEZHOU
F	ADD PIN POSITION	15AUG22	BEZHOU
G	UPDATE PS DRAWING AND SC WITH "▽"	26MAY25	BEZHOU
H	ADD LEAKAGE INDUCTANCE SEPC.	09DEC25	BEZHOU
I	REMOVE NOTES : "TO ORDER TAPE & REEL PACKAGING ADD A "T" SUFFIX" ON PAGE 1	26MAY26	BEZHOU

© Copyright, 2026. Pulse Electronics Corp. All rights reserved. Pulse confidential & proprietary. (05/26/26)

PRODUCT DESCRIPTION	TLA DRAWING	PS DRAWING	SHEET	PART NO.	DATASHEET REV.
TRANSFORMER/CMC,4.3kVDC ISO,SGL,SMT	HMU2103NL-14	PS-2303.002-A	5 OF 5	HMU2103NL	I