

Product change notification (PCN)

Title / short description	Approval extension and printing change on Heavycon HC-M-02-03-04 modules and HC-HS-06 inserts
Affected article category	Connector
Change category	Approval, Form and appearance
Change number	CAF250106-00
Reason for PCN/PDN Revision	

Purpose/objective of the change

As part of the continuous improvement process, the UL and CSA certifications are being extended. The product markings and label will be updated accordingly

Detailed description of the change

As part of our continuous commitment to quality and regulatory compliance, the affected products have received enhanced UL and CSA certifications. To reflect these upgraded approvals, the product markings will be updated accordingly. The improved certifications and updated markings offer the following advantages:

Expanded acceptance in global markets through strengthened UL/CSA compliance.

Simplified product integration for end users and system certifiers due to updated labeling transparency.

Identifying characteristics

The changes to the printing are listed in the attached PDF file.

Start of Production (SOP)	-	Last Time Delivery (LTD)	-
Effective date (EOP)	2026-07-06	End of Service (EOSR)	-
End of Sales (EOS)	-		

Short-term change (< 6 months) or discontinuation (< 12 months), due to:

- | | | |
|---|--|--|
| <input type="checkbox"/> Software / Firmware Bugfix | <input type="checkbox"/> Short-term delivery stop by supplier | <input type="checkbox"/> Short-term recall by supplier |
| <input type="checkbox"/> Force majeure | <input checked="" type="checkbox"/> Product improvement with customer benefits | |
| <input type="checkbox"/> Others | | |

Attachments

- CAF250106.pdf
- Material_list.csv
- PCN-CAF250106-00_EN

Material list

Item no.	Item Type	Hardware old	Firmware new	Item no.	Substitute item Type
1031080	HC-HS-06-I-PT-F	0	1		
1031082	HC-HS-06-I-PT-M	0	1		
1424218	HC-M-03-PT-F	0	1		
1424219	HC-M-03-PT-M	0	1		
1424220	HC-M-04-PT-F	0	1		
1424221	HC-M-04-PT-M	0	1		
1424222	HC-M-02-PT-F	0	1		
1424223	HC-M-02-PT-M	0	1		

Empowering the All Electric Society 



Welcome

CAF250106



CAF250106

Agenda

- > Change Description
- > Visual Changes
- > Article list

CAF250106

Change Description

We would like to inform you about an upcoming product improvement concerning the items listed in this notification. As part of our continuous commitment to quality and regulatory compliance, the affected products have received enhanced UL and CSA certifications. To reflect these upgraded approvals, the product markings will be updated accordingly. The improved certifications and updated markings offer the following advantages:

- Expanded acceptance in global markets through strengthened UL/CSA compliance.
- Simplified product integration for end users and system certifiers due to updated labeling transparency.

These updates affect only the markings on the product surface. The product design, functionality, materials, and performance characteristics remain unchanged.

CAF250106

Visual Changes: 1031080

V/C 0 (current)

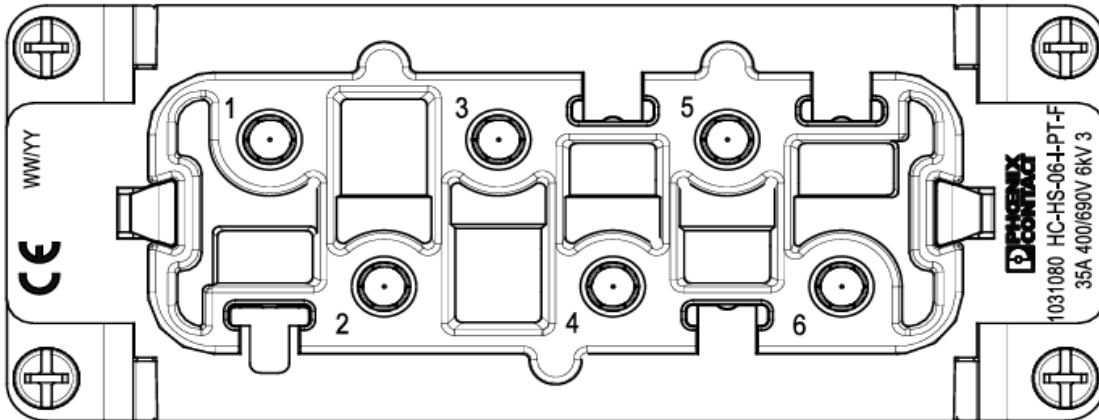

V/C 1 (new)

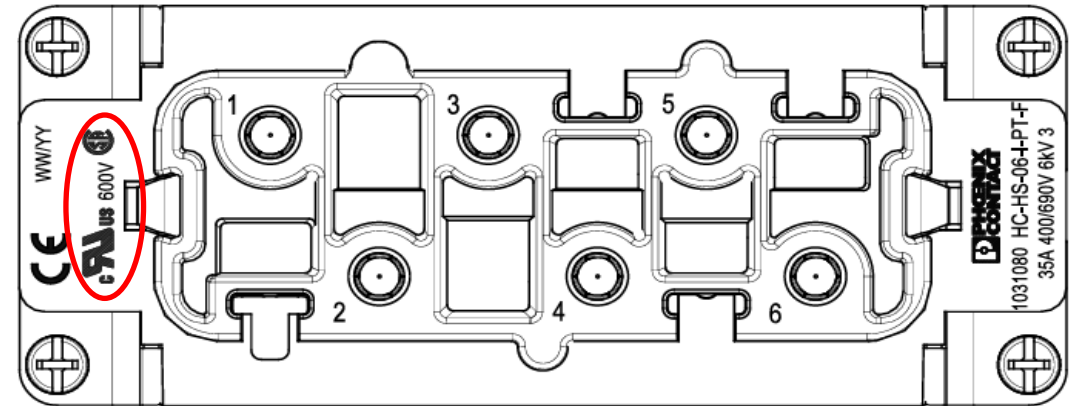

CAF250106

Visual Changes: 1031082

V/C 0 (current)

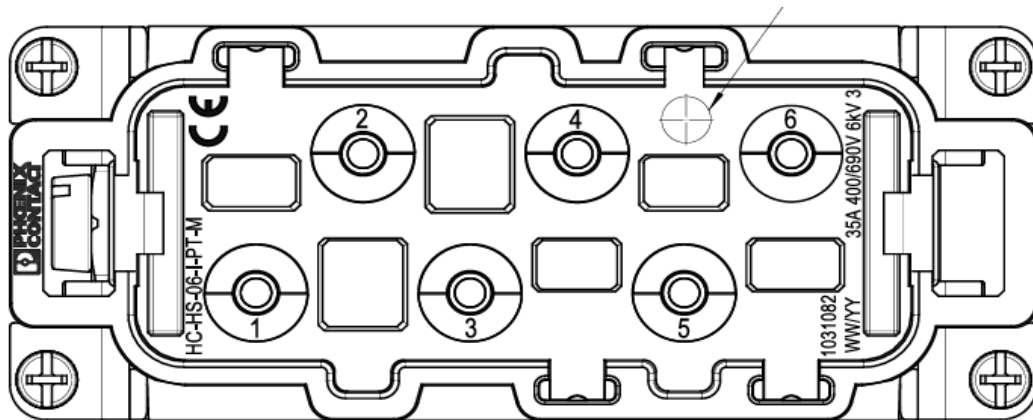

V/C 1 (new)

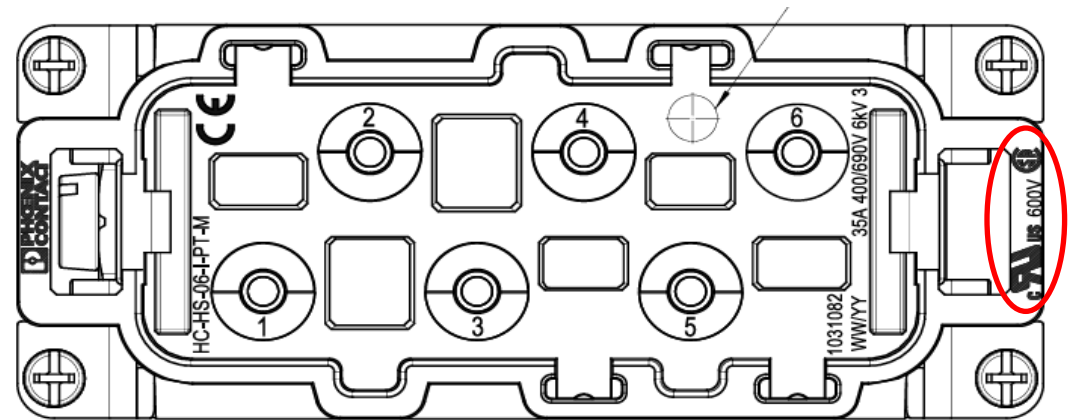

CAF250106

Visual Changes: 1424218

V/C 0 (current)

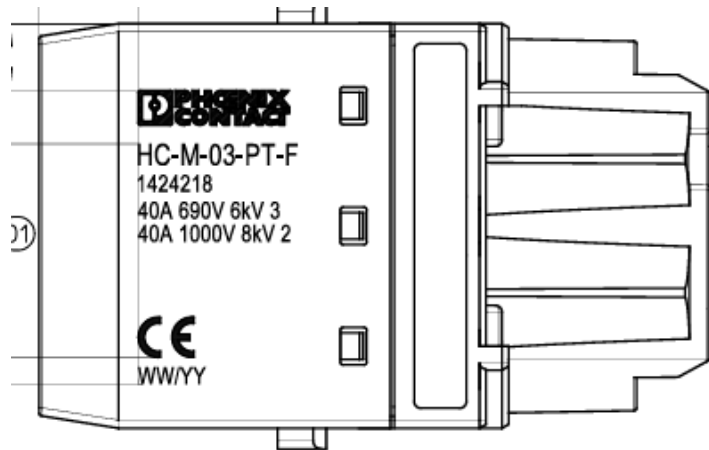

V/C 1 (new)

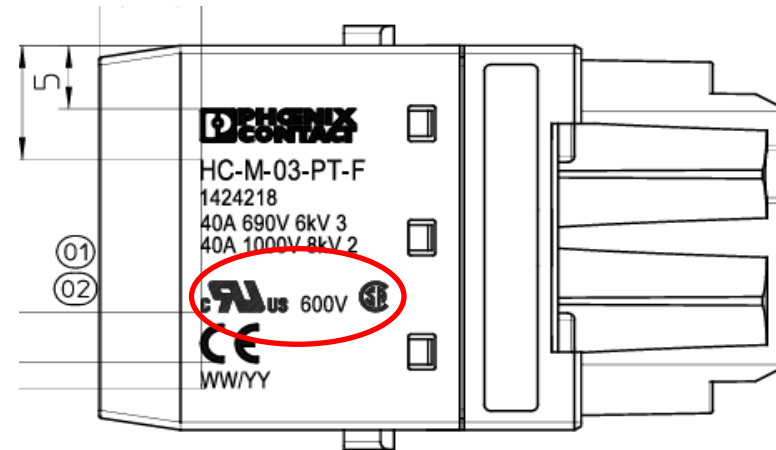

CAF250106

Visual Changes: 1424219

V/C 0 (current)

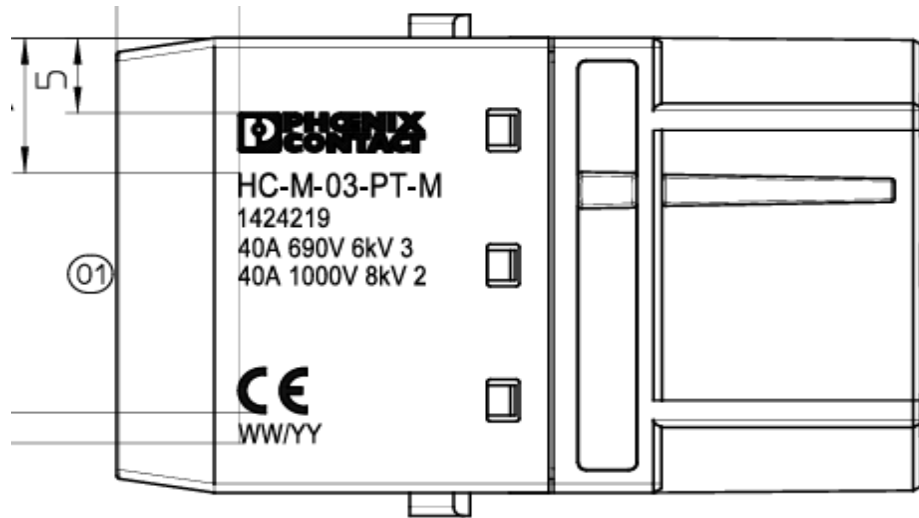

V/C 1 (new)

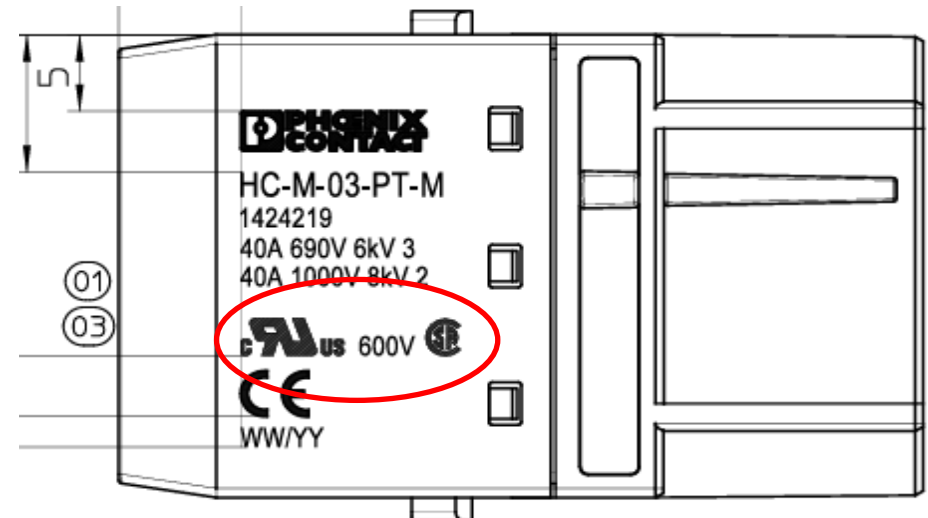

CAF250106

Visual Changes: 1424220

V/C 0 (current)

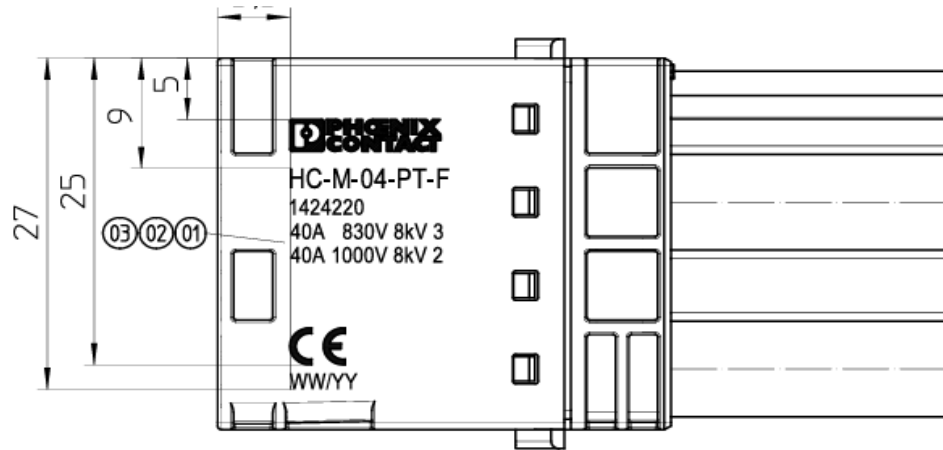

V/C 1 (new)

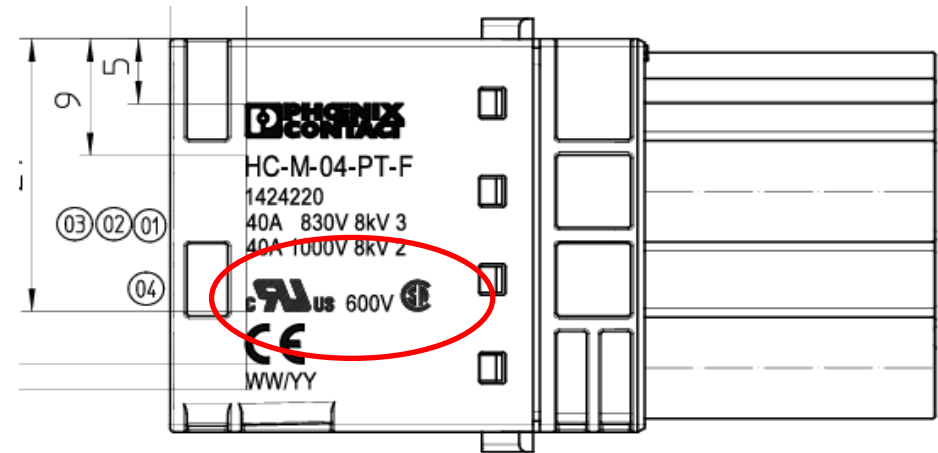

CAF250106

Visual Changes: 1424221

V/C 0 (current)

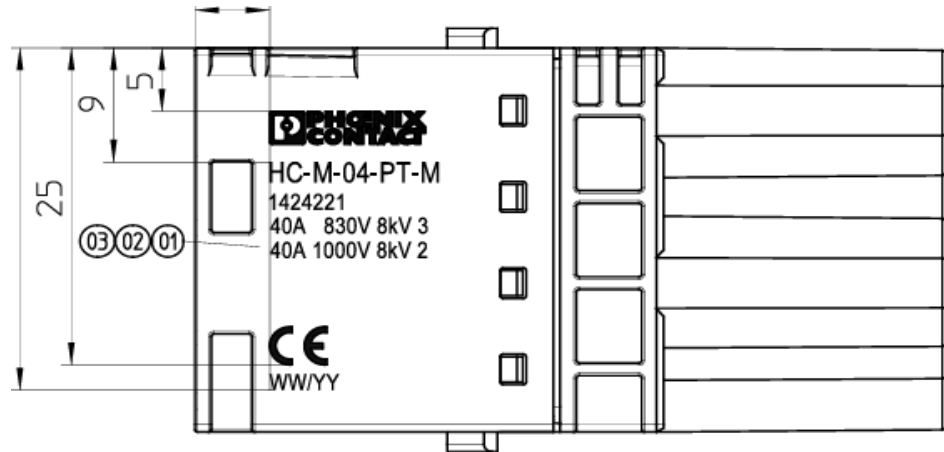

V/C 1 (new)

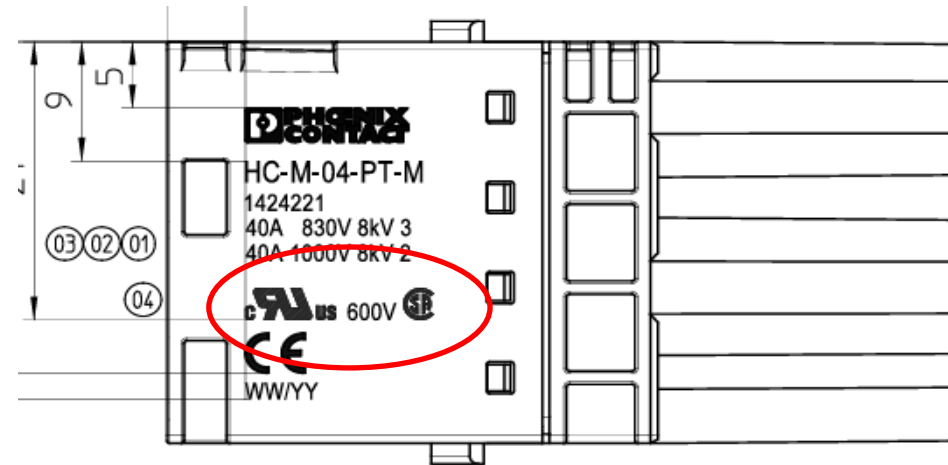

CAF250106

Visual Changes: 1424222

V/C 0 (current)

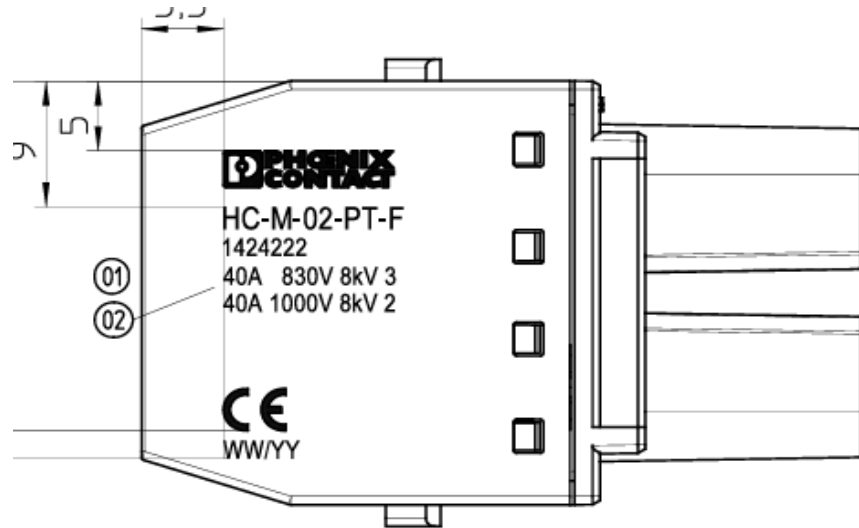

V/C 1 (new)

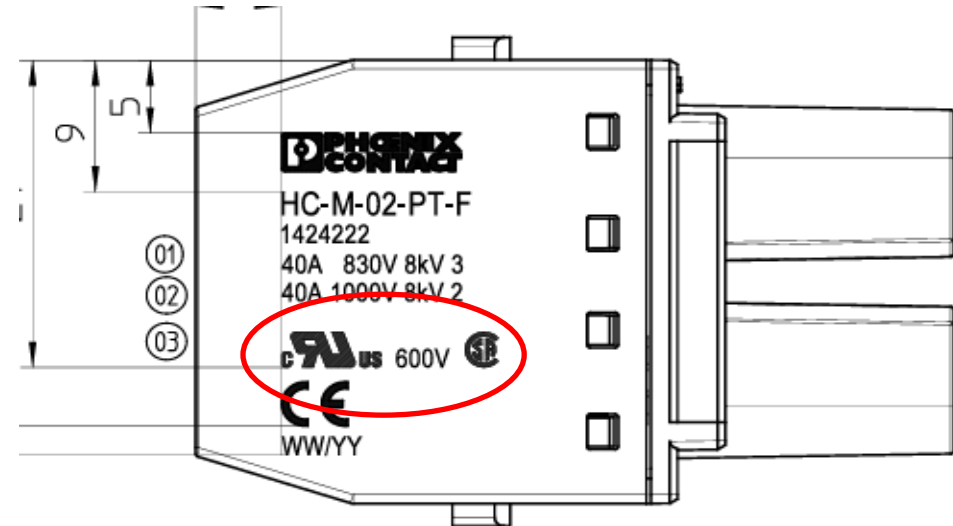

CAF250106

Visual Changes: 1424223

V/C 0 (current)

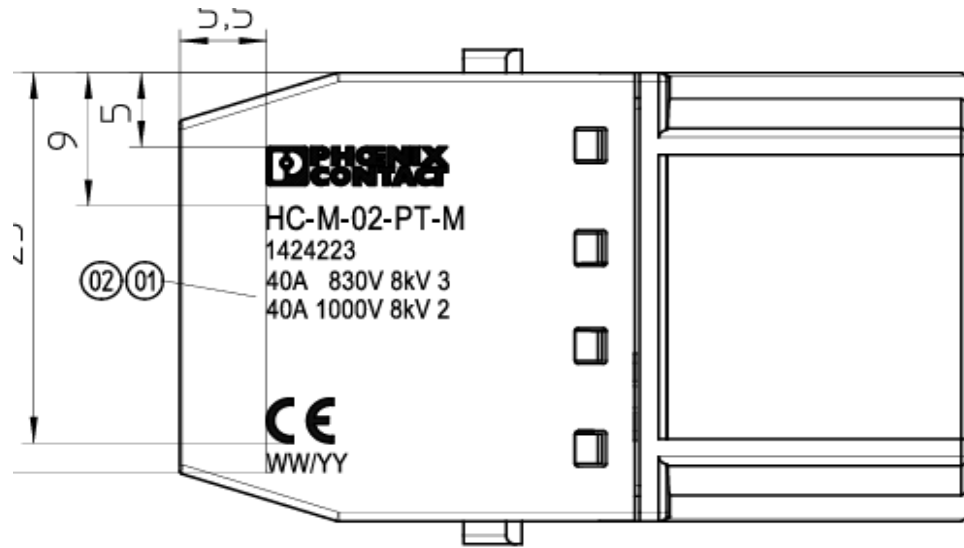

V/C 1 (new)

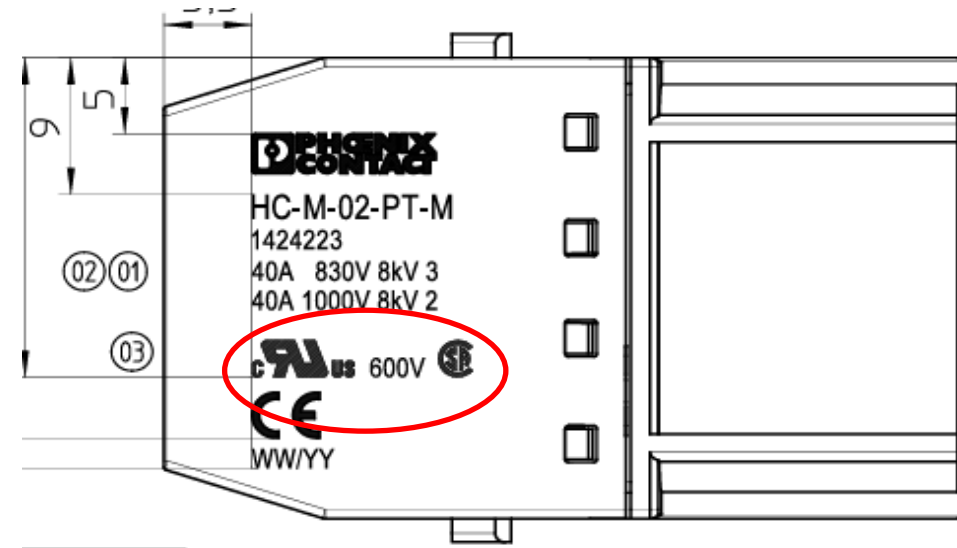

Article list

Article	Description	Old rev.	New rev.
1031080	HC-HS-06-I-PT-F	0	1
1031082	HC-HS-06-I-PT-M	0	1
1424218	HC-M-03-PT-F	0	1
1424219	HC-M-03-PT-M	0	1
1424220	HC-M-04-PT-F	0	1
1424221	HC-M-04-PT-M	0	1
1424222	HC-M-02-PT-F	0	1
1424223	HC-M-02-PT-M	0	1

Item no.;Type;old;new;Substitute item;Replacement product designation;eCl@ss 13.0;
1031080;HC-HS-06-I-PT-F;0;1;;;27440205;
1031082;HC-HS-06-I-PT-M;0;1;;;27440205;
1424218;HC-M-03-PT-F;0;1;;;27440217;
1424219;HC-M-03-PT-M;0;1;;;27440217;
1424220;HC-M-04-PT-F;0;1;;;27440217;
1424221;HC-M-04-PT-M;0;1;;;27440217;
1424222;HC-M-02-PT-F;0;1;;;27440217;
1424223;HC-M-02-PT-M;0;1;;;27440217;

PCN/PDN Number	Customer Number	Company Name	Street	Postcode/Zip Code
CAF250106	401641	TTI, INC.	2441 NORTHEAST PKWY	76106
CAF250106	401641	TTI, INC.	2441 NORTHEAST PKWY	76106
CAF250106	401641	TTI, INC.	2441 NORTHEAST PKWY	76106
CAF250106	401641	TTI, INC.	2441 NORTHEAST PKWY	76106

City	Phoenix Contact Item-Nr. (changed/discontinued article)
FORT WORTH	1424218
FORT WORTH	1424221
FORT WORTH	1424220
FORT WORTH	1424219

Phoenix Contact Item Designation (changed/discontinued article)	Report Date	Substitute Item
HC-M-03-PT-F	28.04.2026	
HC-M-04-PT-M	28.04.2026	
HC-M-04-PT-F	28.04.2026	
HC-M-03-PT-M	28.04.2026	

Replacement Product Designation