

Product Change Notification Number: 26002

Notification Date: 3/24/26

Title: Manufacturing equipment obsolescence.

Product Identification: NavCom / Extant filter pins:

8833300029-7 Rev H (1-842849-1)

8833300029-8 Rev H (1-842849-2)

8833300029-9 Rev H (859628-5)

8833300029-10 Rev H (859668-5)

**Reason for
Change:**

Material / Composition

Processing / Manufacturing

Design / Firmware

Logistics

Manufacturing Location

Quality / Reliability

Change Description:

The manufacturing equipment utilized to solder the above filter pins is unique and no longer supported with replacements parts; it has become uneconomical to maintain and will be obsoleted once current customer purchase orders are fulfilled.

The uniqueness of the equipment is the ability to apply localized heat to the filter pin; thus, the reflow of the solder is controlled to a narrow band. This controls the solder wicking onto the gold lead and minimizes the solder fillet height.

We are proposing utilizing our standard nitrogen backfilled convection oven to perform the task; this is a more robust, industry standard solder reflow process with improved reliability providing consistent solder joints. However, there are some negative side effects associated with this type of soldering process for these designs.

The convection oven does not provide localized heating; it applies constant heat throughout the chamber(s) while bringing up the entire filter pin to the same temperature. The negative effect is increased solder run-up (wicking) onto the lead, eyelet and larger fillets protruding at the interface of lead/cap solder joint.

Included below are the four filter pin mechanical drawings that have been marked up to adjust the allowable solder requirement for the proposed soldering process. The exceptions are noted in red.

Change Description:

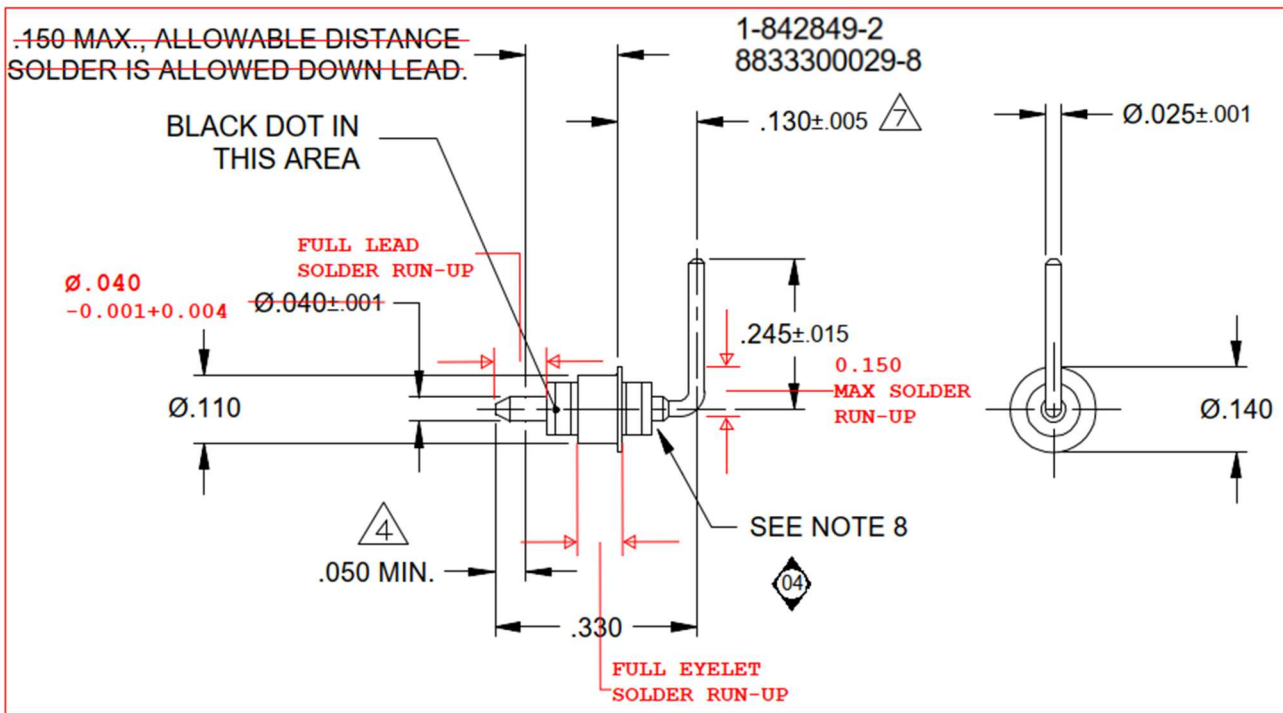
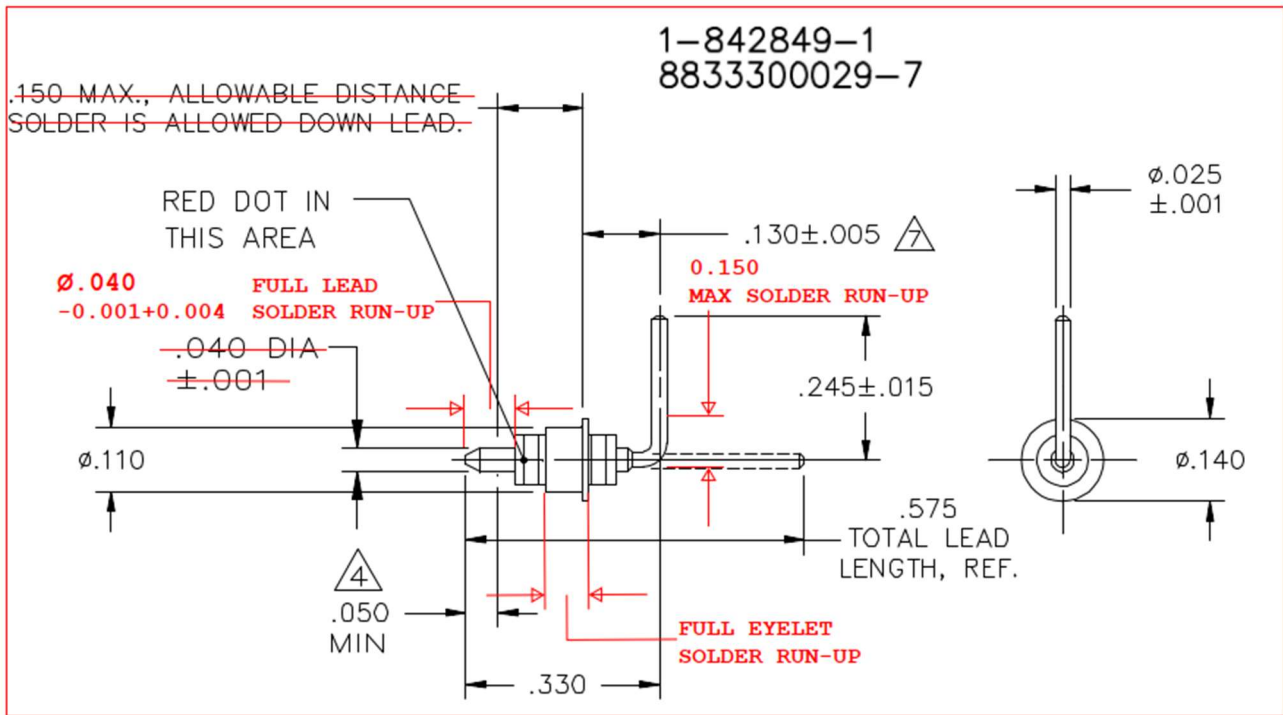

Change Description:

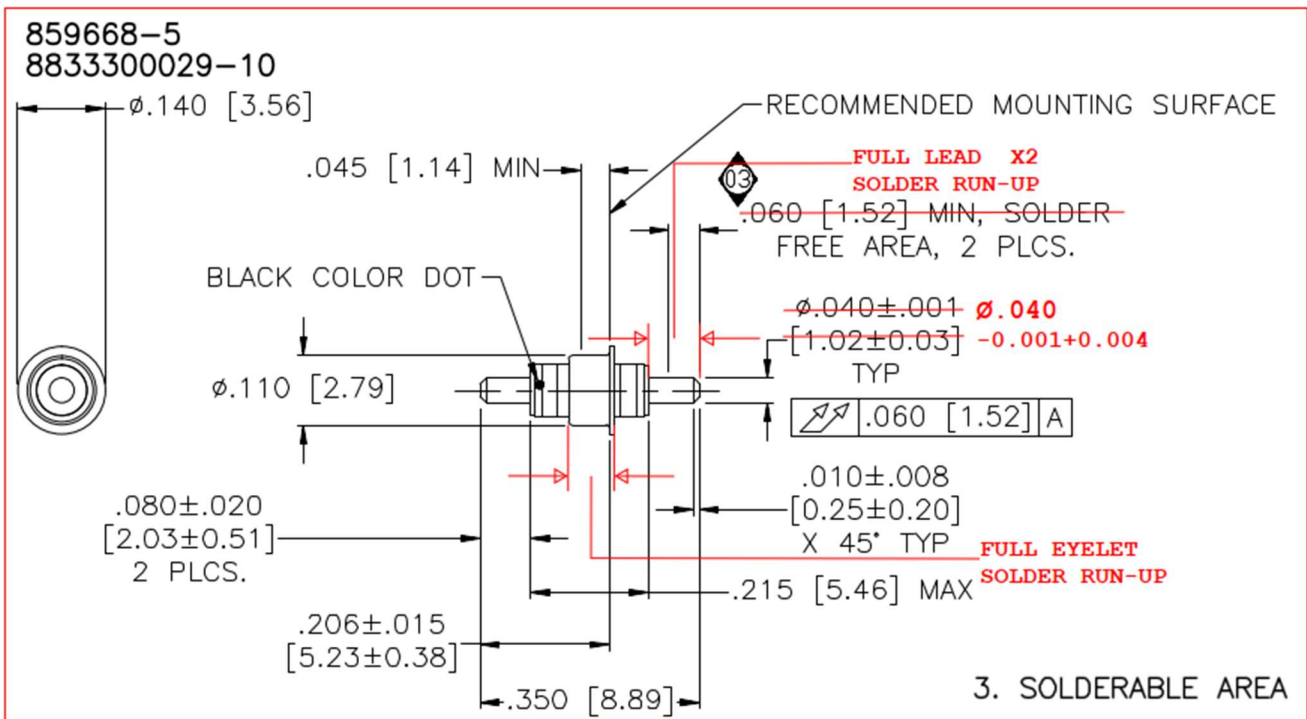
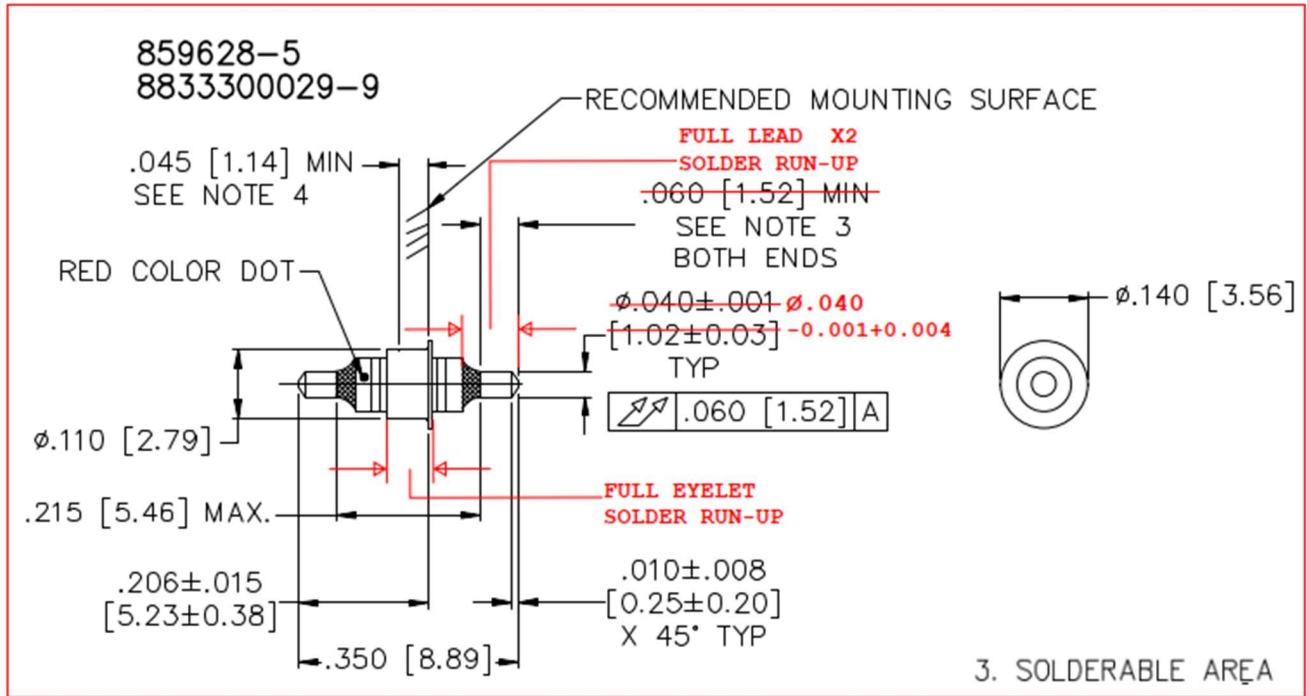

Identification Method to Distinguish Change: Date Code on package marking.

SCI Contact: Please contact your SCI Sales Representative or Distributor for additional information (when replying via e-mail please include PCN number in subject line).

Sil Leandro
Product/Application Engineer
Spectrum Control, Inc.
8061 Avonia Road
Fairview, PA 16415
Email: Silverio.Leandro@am.SpectrumControl.com
Phone: (814) 474-0392

CUSTOMER ACKNOWLEDGEMENT OF RECEIPT: SCI requests you acknowledge receipt of this PCN. Please complete and email to Silverio.Leandro@am.SpectrumControl.com and the SCI Contact listed above. In your acknowledgement, you can grant approval or request additional information. **SCI will deem this change accepted unless specific conditions of acceptance are provided in writing within 30 days from the date of this notice.**

Company: Name: Title: Date: Email Address: Location: Comments:	
--	--