

# Get connected

with KOSTAL high performance connector systems

## KKS GCN2500042 Change of supply chain

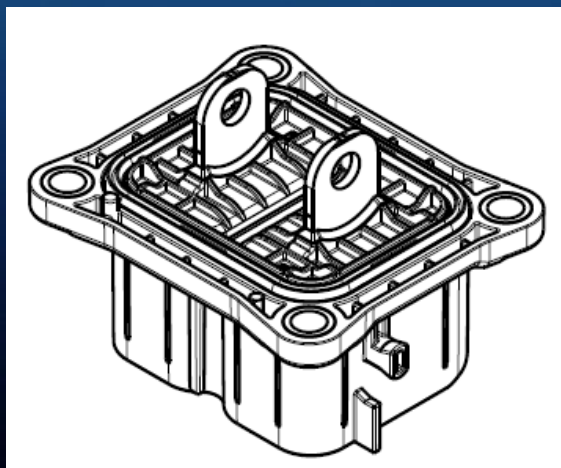

KVD 2026

1. Overall scope of affected parts
2. Reason for change
3. Change description
4. Supply chain
5. Affected documents
6. PPAP documents
7. Validation
8. Time schedule
9. Contact / feedback / approval

# 1. Overall scope of affected parts

Part description	KOSTAL current P/N	KOSTAL new P/N	Index current	Index new	OEM	OEM current P/N	OEM new P/N	OEM Index current	OEM Index new
Tab header . 2-w.PLK14,5	12212810	No change	00	no change	-	-	-	-	-

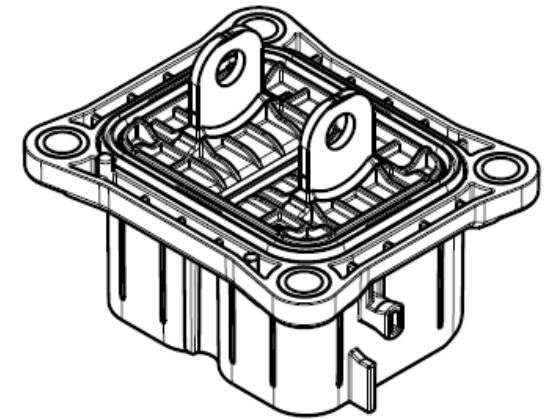

Please refer to the cover sheet for a description of the scope of delivery relevant to your company.

## 2. Reason for change

- Supply chain update

### 3. Change description

- KOSTAL will change it's current supply chain due to strategic reasons (Combined assembly equipment and majority of sales located in China)
- Molding and assembly will be transferred from KKS Czech Republic to KKS China
- There is no change to fit, form and function of the article

## 4. Supply chain

### Current supply chain

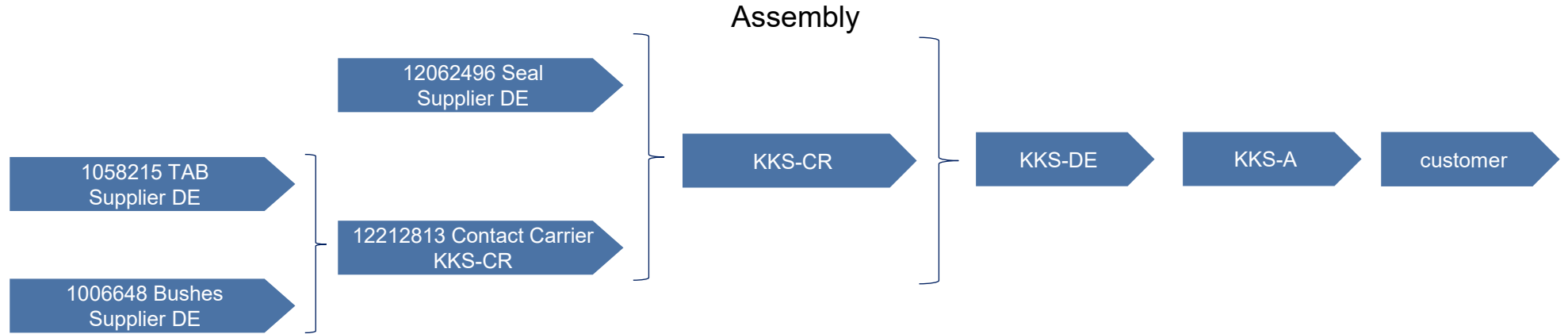

### New supply chain

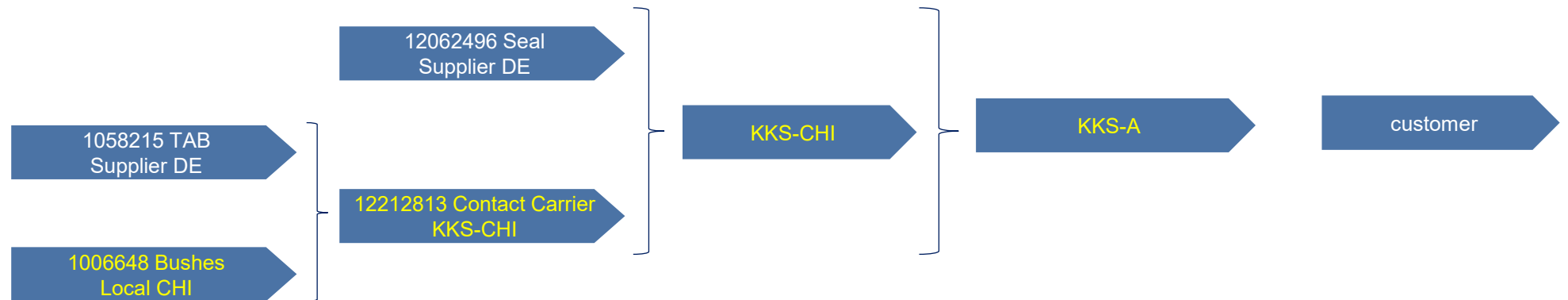

## 5. Affected documents

No documents affected by this change

### PPAP Level 4

- PSW
- drawing and dimensional report
- material certificates (APZ)
- machine capability (MFU)
- material data (IMDS)
- flowchart
- control plan
- part history
- technical cleanliness confirmation

Proposal by KKS

According validation matrix DIN TS70214

PG 0	Resistance Test
PG 1	Dimensions
PG 2	Material and Surface Analysis, Contacts
PG 3	Material and Surface Analysis, Connectors and Sealing Elements
PG 7	Connector Handling and Functional Integrity

## 8. Time schedule

- PCN communication: week 23 / 2026
- Buffer stock production: to week 34 / 2026 (covering week 08 / 2027)
- Installation at KKS-CHI week 40 / 2026
- Samples availability: week 44 / 2026
- Validation tests: week 45 – 48 / 2026
- PPAP to the customer: week 49 / 2026
- First parts delivery: week 04 / 2027

### Technical questions for changing

- General questions: KOSTAL Kontakt Systeme Change Management, [pcn-kks-de@kostal.com](mailto:pcn-kks-de@kostal.com)

### Feedback

- Which PPAP documents do you need?
- Please let us know if your internal article number will be changed due to this change.
- If you need samples, please tell us the correct address and contact person.

### Approval

Please inform us if there are objections regarding the planned delivery date. Failing response during the next 14 days after reception will be evaluated as approved. Please contact the above mentioned persons, if there are any further questions.