

# Amphenol PCD

Engineering Change Request		ECR Number	R09332W
Initiator:	Flame.Li	Date:	2026.06.10

Part number description

Item	K3 Code material part numbers	Drawing/ Doc Number	Version of current related document	New Version
	Due to the large number of part numbers involved, please refer to the attached part number table.			

Reason of change:

- Customer requirement (list the feasibility analysis of customer specification: \_\_\_\_\_)  
 Supplier request (list the PCR number: \_\_\_\_\_ )  
 internal improvement     corrective     other

Please describe here in detail:

The CHD14021 series 180° socket has undergone adjustments and optimizations to its internal black plastic structure for the following reasons:

The current plastic parts have relatively thick walls. This adjustment involves reducing the wall thickness of the plastic parts to optimize the injection molding process.

This change does not affect product performance; the old materials can still be used normally, allowing for a natural transition between the old and new materials.

Using the A key as an example:

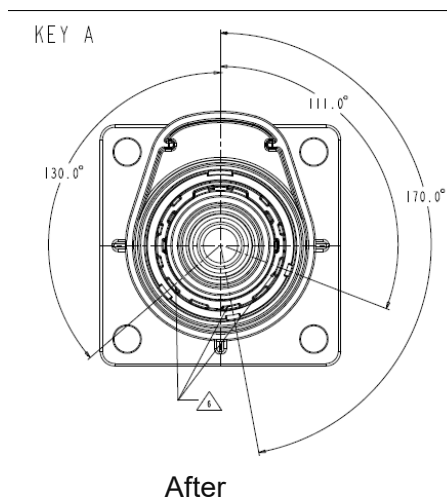
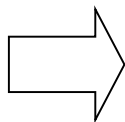
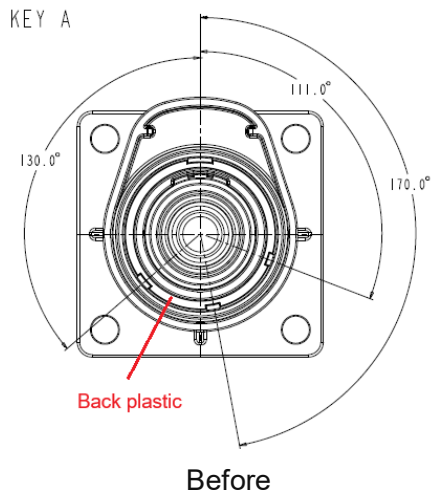

# Amphenol PCD

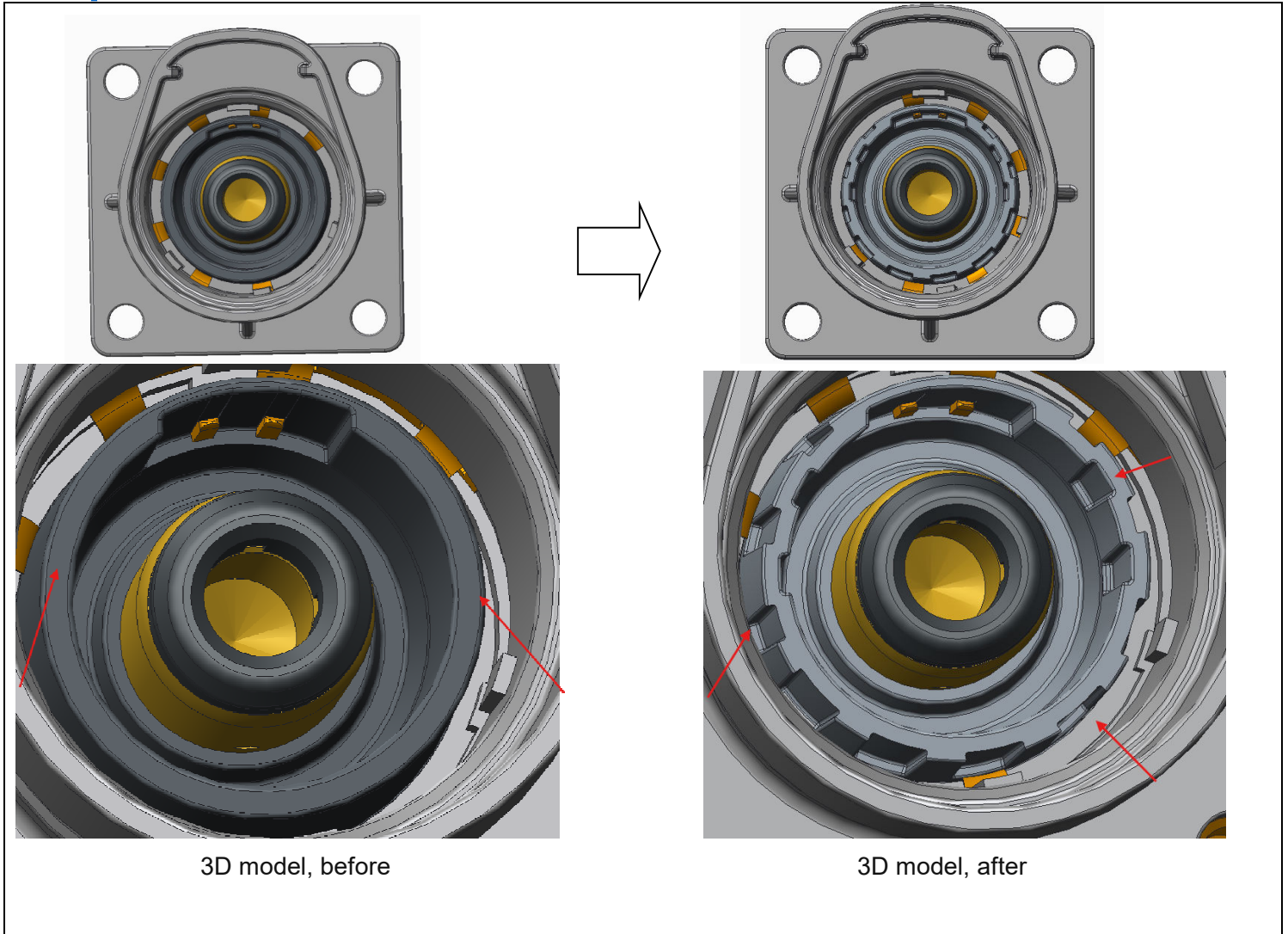

# Amphenol PCD

Change level and impact assessment (Please tick in the appropriate position)

Change level	Change content	Whether to notify the customer
Level 1	<input type="checkbox"/> Operator change	<input type="checkbox"/> It is not necessary to notify the customer for approval
	<input type="checkbox"/> Correct the clerical errors of the drawing, BOM, etc., and this change will not affect the production process	
Level 2	<input type="checkbox"/> Change of Main production equipment or tools/Jigs	<input checked="" type="checkbox"/> <b>Customers should be notified for approval</b> <input type="checkbox"/> It is not necessary to notify the customer for approval, the reasons are as follows:  <u>Note: Improve the electrical properties of products without affecting the use of existing products.</u>
	<input type="checkbox"/> Change of main measuring equipment or tools/Jigs	
	<input type="checkbox"/> Appearance changes that do not affect product functions	
	<input type="checkbox"/> Changes in production process or processing technology	
	<input type="checkbox"/> Product structure or specification changes that have not been transferred to mass production	
	<input checked="" type="checkbox"/> Product structure or specification changes that have been transferred to mass production	
Level 3	<input type="checkbox"/> Supplier's production process change or supplier's production site change or addition or replacement of suppliers	<input type="checkbox"/> Customers should be notified for approval
	<input type="checkbox"/> Change of production site	
	<input type="checkbox"/> Product material changes	
	<input type="checkbox"/> Changes proposed by the customer	
<p>Before change</p>		<p>After change</p>
<p>Disposition of old materials</p> <input type="checkbox"/> Rework <input checked="" type="checkbox"/> Use as it is <input type="checkbox"/> scrap <input type="checkbox"/> Other (please describe): _____ <input type="checkbox"/> N/A		<p>Plan or require material time switching</p> <p><u>Jul-03-2026</u></p>
<p>Approval by the supervisor of requester.:</p> <p style="text-align: center;"><i>Derek</i></p>		<p>Approval by the head manager of the request dept.:</p> <p style="text-align: center;"><i>Chingtung</i></p>
<p>Customer approval:</p> <input type="checkbox"/> Approved <input type="checkbox"/> No approved <input type="checkbox"/> Conditional approval (please describe) : Signature: _____ Date: _____		
<p>Remark:</p>		

**Subject:** ECR R09332W-TTI, INC.(EU)- CHD14021 Series Design Change

**CAUTION:** This email is from an EXTERNAL source.

Dear TTI Team,

The CHD14021 series 180° socket has undergone adjustments and optimizations to its internal black plastic structure for the following reasons: The current plastic parts have relatively thick walls. This adjustment involves reducing the wall thickness of the plastic parts to optimize the injection molding process. **This change does not affect product performance; the old materials can still be used normally, allowing for a natural transition between the old and new materials.**

Attached pls find the ECR, pls kindly note and help inform your end customer to sign back within 2 weeks if no problem, no response within 2 weeks will be deemed as consent.

Thank you

\*\*\*

**Related your PN and open orders as below:**

CHD14021A101

CHD14021B101

Customer Name	Order Date	Sales Order	Customer Po
TTI, INC.(EU)	05/28/26	AS078690	4025111
TTI, INC.(EU)	05/28/26	AS078690	4025111

**Sandy Xia | Amphenol PCD Shenzhen**

O: +86 755-8173-8000 ext.8533 | M: +86 157-7922-5480

CONFIDENTIALITY. This electronic mail and any files transmitted with it may contain information proprietary to TTI, Inc. or one of its subsidiaries or affiliates, and are intended solely for the use of the individual or entity to whom they are addressed, shall be maintained in confidence and not disclosed to third parties without the written consent of the sender. If you are not the intended recipient or the person responsible for delivering the electronic mail to the intended recipient, be advised that you have received this electronic mail in error and that any use, dissemination, forwarding, printing, or copying of this electronic mail is strictly prohibited. If you have received this electronic mail in error, please immediately notify the sender by return mail. Thank you for your compliance.

---

TTI, Inc.

Zweigniederlassung der Firma TTI, Inc., Wilmington, Delaware, USA

Ganghoferstr. 34

82216 Maisach-Gernlinden

Germany

HRB München: 170722

USt-Id-Nr.: DE 814817762

Ständiger Vertreter der Niederlassung Sven Christian Lippert, Glyn Dennehy

Hier Klicken für unsere [Allgemeinen Verkaufsbedingungen \(AGBs\)](#)

Click here for our [General Conditions of Sale](#)

---