



RUGGEDIZED OPTICAL BACKPLANE INTERCONNECTS

FOR VITA 66.1 AND 66.4

High-Density Optical Modules for Demanding
Embedded Computing Application

RUGGEDIZED OPTICAL BACKPLANE INTERCONNECTS

Support VITA 66.1 and 66.4 Standards



RUGGED RELIABILITY

- Meets VITA 66.1 and 66.4 standards
- Common protective cover is made of anti-static material
- Receptacle (backplane) connector includes two robust guide pins for blind mating
- Connector mounting screws contain pre-applied Nylok patch to help withstand vibration

VERSATILE

- Full-size VITA 66.1 or half-size VITA 66.4 modules
- Plug (daughtercard) connector housing contains a slot feature to facilitate cleaning the MT interfaces
- Locating post features helps ensure proper position on the backplane and daughtercard

HIGH PERFORMANCE

- Connectors designed to maximize optical performance, accommodating up to two MT ferrules
- Receptacle connector insert floats relative to the shell, providing ± 0.25 mm planar floating alignment capability

APPLICATIONS

- Embedded Computing
- Avionics and Vetrionics
- Secure Communications
- Processing
- Radar
- Imaging and Targeting

TE Connectivity's (TE) Ruggedized Optical Backplane interconnect system provides a high-density, blind-mate optical interconnect in a backplane/daughtercard configuration. The fiber optic ribbon cable interconnect feeds through the backplane to removable system modules using MT ferrules.

The optical module are available in two sizes:

- **VITA 66.1 modules are full width and accommodate two MT ferrules.**
- **VITA 66.4 modules are half width and hold a single MT ferrule. Two modules can be fit into the same space as a VITA 66.1 modules.**

Designed for rugged embedded computing applications, the optical modules are compatible with VPX and other high-performance standards.

MECHANICAL/ENVIRONMENTAL

- **Mating Force (per 12-fiber MT ferrule):**
Min: 7.8 N (1.75 lb)
Max: 11.8 N (2.65 lb)
- **Durability:** 100 cycles, tested per EIA-455-21
- **Shock:** 50 g, sawtooth, 11 ms pulse duration, tested per TIA/EIA-455-14, condition E
- **Random Vibration:** 11.95 grms, 50 to 2000 Hz, 2 hr per plane.
Tested per TIA/EIA-455-11, test condition V1-D
- **Storage Temperature:** -55°C to +85°C
- **Operating Temperature:** -20°C to +85°C
- **Thermal Aging:** 168 hrs at +85°C
- **Humidity, Steady-State:** 95% RH at 60°C
- **Temperature Cycling:** 21 cycles between -20°C and +85°C

MATERIALS

- **Connector Shell and Housing:** Aluminum alloy 6061, clear-chromate conversion-coated (RoHS compliant)
- **Alignment Posts and Screws:** Stainless steel, 300 series, passivated (RoHS-compliant)

STANDARDS AND SPECIFICATIONS

- **TE Application Specification:**
VITA 66.1: 114-32050
VITA 66.4: 114-32144
- **TE Product Specification:**
VITA 66.1: 108-2467
VITA 66.4: 108-2467-1
- **TE Qualification Test Report:**
VITA 66.1: 501-134012
VITA 66.4: 501-134012-1

TE Components . . . TE Technology . . . TE Know-how . . .

AMP | Agastat | CII | Hartman | Kilovac | Microdot | Nanonics | Polamco | Raychem | Rochester | DEUTSCH
SEACON Phoenix | L.L. Rowe | Phoenix Optix | SEACON

Get your product to market faster with a smarter, better solution.

Part Numbering and Dimensions

Interface	Part No.	
	Backplane	Daughtercard
VITA 66.1	2000973-1	2000974-1
VITA 66.4	2226880-1	2226881-1
MT Ferrule Kit (12 Fiber, Multimode)	2102866-1	2102866-2

VITA 66.1

(Shown Assembled with Reference MT Cable Assemblies Installed)

Backplane Module Part No. 2000973-1

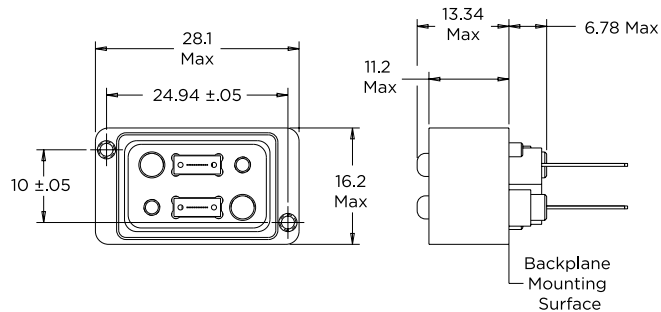

Daughtercard Module Part No. 2000974-1

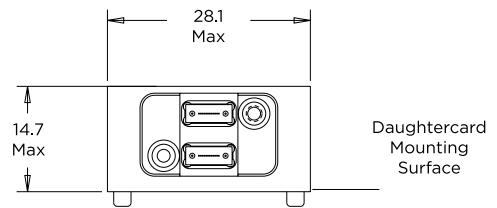

Protective Cover Part No. 2102321-1

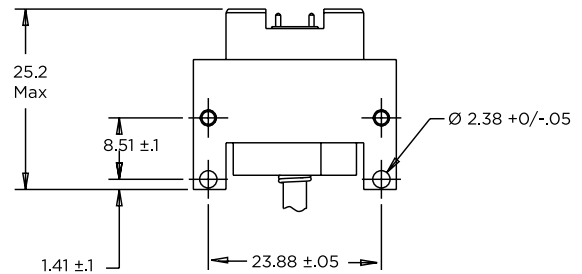
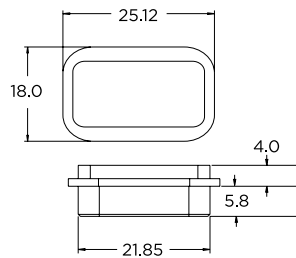

VITA 66.4

(Shown Assembled with Reference MT Cable Assemblies Installed)

Backplane Module Part No. 2226880-1

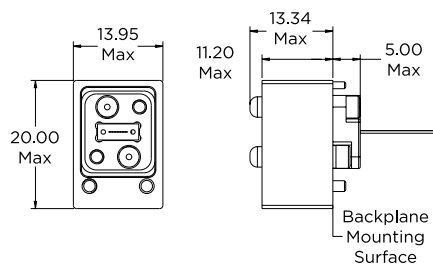

Daughtercard Module Part No. 2226881-1

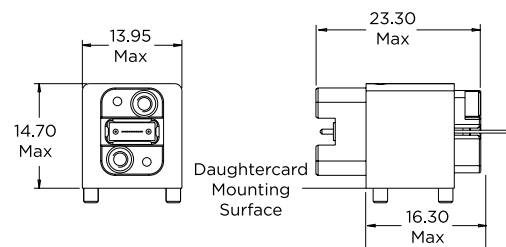

For More Information

TE Technical Support Center

North America	+1 800 522 6752
Asia Pacific	+86 0 400 820 6015
Austria	+43 1 905 601 228
Baltic Regions	+46 8 5072 5000
Benelux	+31 73 6246 999
Czech Republic	+420 800 701 462
France	+33 1 34 20 86 86
Germany	+49 6251 133 1999
Hungary	+36 809 874 04
Italy	+39 011 401 2632
Nordic	+46 8 5072 5000
Poland	+48 800 702 309
Russia	+7495 790 790 2
Spain/Portugal	+34 93 2910366
Switzerland	+41 52 633 66 26
United Kingdom	+44 800 267 666

Follow us on Twitter for all the latest product news
@TEConnectivity, and on Facebook, TEConnectivity.

te.com/vita66

© 2015 TE Connectivity Ltd. family of companies. All Rights Reserved.

1-1773708-2 ADM/RRD 1.5M 09/2015

TE, TE Connectivity and the TE connectivity (logo) are trademarks of the TE Connectivity Ltd. family of companies.

Nylok is a trademark of Nylok LLC. Other product or company names mentioned herein may be trademarks of their respective owners.

While TE has made every reasonable effort to ensure the accuracy of the information herein, nothing herein constitutes any guarantee that such information is error-free, or any other representation, warranty or guarantee that the information is accurate, correct, reliable or current. The TE entity issuing this publication reserves the right to make any adjustments to the information contained herein at any time without notice. All implied warranties regarding the information contained herein, including, but not limited to, any implied warranties of merchantability or fitness for a particular purpose are expressly disclaimed. The dimensions herein are for reference purposes only and are subject to change without notice. Specifications are subject to change without notice.

Consult TE for the latest dimensions and design specifications.