

SLEEP MONITOR STRIP

APPLICATION NOTE

Description

The Sleep Monitor Strip is a strip of Piezo Film (piezoelectric PVDF polymer) 800mm long and 8mm wide. The active electrode area is 698.5mm long and 3mm wide. The total thickness of the strip is around 50 microns, making it extremely flexible and entirely imperceptible when placed under the body. Electrical interconnection is made via two crimped solder tabs. The strip produces a charge or voltage output when subjected to dynamic strain (change in length). When mounted across a mattress in line with the chest/heart, the strip can detect tiny changes in load or center of gravity due to breathing and pulse of the occupant, as well as gross body or limb movement. These signals may then be assessed over an extended time period (e.g. overnight) and may be indicative of duration, phase, or quality of sleep.



The sensor requires no external power and is therefore ideal for use with battery-operated equipment where power consumption must be kept to a minimum.

Disclaimer

This product is offered as a low-cost short-term solution for evaluating the suitability of Piezo Film for vital signs or sleep monitoring. The Sleep Monitor Strip is not sealed against moisture. Exposure to moisture may affect electrical performance of the sensor. The printed ink electrodes have a thin protective coating but are not intended to provide full electrical insulation. The sensor element is not electrically shielded, and the sensor and/or any interface electronics connected to it may be susceptible to RFI/EMI and/or electrostatic sensitivity. Additional mechanical protection may be required for long-term use. TE Connectivity makes no warrant of performance or suitability for any specific end use or application.

Typical properties

Parameter	Min	Typ	Max	Units/condions
Overall length	797.5	800.0	802.5	mm, excluding solder tabs
Overall width	7.7	80.0	8.3	mm
Active electrode length	691.5	698.5	701.0	mm
Active electrode width	2.7	3.0	3.3	mm
Capacitance	5.49	7.3	9.25	nF@1kHz
Dissipation Factor	-	0.02	0.03	@1kHz
Strain Sensitivity (V)	-	0.015	-	V/ $\mu\epsilon$
Strain Sensitivity (Q)	-	110	-	pC/ $\mu\epsilon$
Base film thickness	27	30	33	μm
Yield stress	45	-	-	MPa (stretch direction)

Typical response

(on top of mattress, under mattress protector)

0.1Hz data	Q p-p	V p-p OC
Pulse	0.5-1 nC	75-150 mV
Breathing	2-7 nC	0.3-1 V
Movement	100-500 nC	10-70 V

Notes/comments

Peak-to-peak charge (Qp-p) and voltage into open-circuit conditions (Vp-p OC) are shown as a very general guide only. Signal levels may be affected by the compliance of mattress, thickness and material of bed linen, occupant's posture/orientation on the bed, body shape, physique and health, and many other factors.

Interface requirements

As with any piezoelectric sensor, the low frequency response of the Sleep Monitor Strip is set by the external circuit to which the sensor is connected. Under true open-circuit conditions, the leakage of charge through the piezo dielectric material is minimal, and the low frequency response extends close to DC (< 1mHz). In practical terms, it is necessary to define a functional limit to avoid long-term drift and potential slow but high-amplitude signals resulting from the pyroelectric response of the film. Adult respiratory rate is generally taken as falling in the range 12 to 18breaths/minute, although this may reduce somewhat during sleep. If we wish to capture, say, down to 10bpm, this requires a network that has minimal attenuation at 0.16Hz.

The Piezo Film Lab Amplifier (TE Part # 1007214-X) offers a selectable lower limiting frequency of 0.1Hz, which is useful in this case. In addition, an upper limiting frequency of 10Hz can be set, which eliminates unwanted 50/60Hz mains (line) interference. A wide range of overall gain is offered, and the Amp may be operated either in charge mode or in voltage mode.

Note that direct connection of the Sleep Monitor Strip to a conventional oscilloscope input (with 1M input resistance) is not recommended, as this will form a high-pass filter with cut-off frequency (to -3dB) at approximately 22Hz. This will significantly attenuate target signals due to breathing or pulse.

To obtain a response to 0.1Hz (-3dB point) with a simple voltage-mode circuit, an input resistance of 220M is required.

Note: if only heart rate is required (and not respiratory rate), then a lower limiting frequency in the range 1 - 3Hz may be sufficient. Applying a high-pass filter at 2Hz, say, will not prevent detection of a train of impulses with a repetition rate of 1 Hz or even lower, as each impulse contains signal energy spread over a band of frequencies.

Note: if an interface circuit is constructed that allows successful detection of pulse (at approximately 1nC or 140mV peak-peak), then this is likely to become saturated when gross bodily movement occurs, with up to 500X higher signal level. If the circuit is also set up to detect breathing with a response down to 0.1Hz, then the effect of saturation and/or time constant settling may cause up to 30s interruption of detection of pulse & breathing after body movement occurs.

Example waveforms

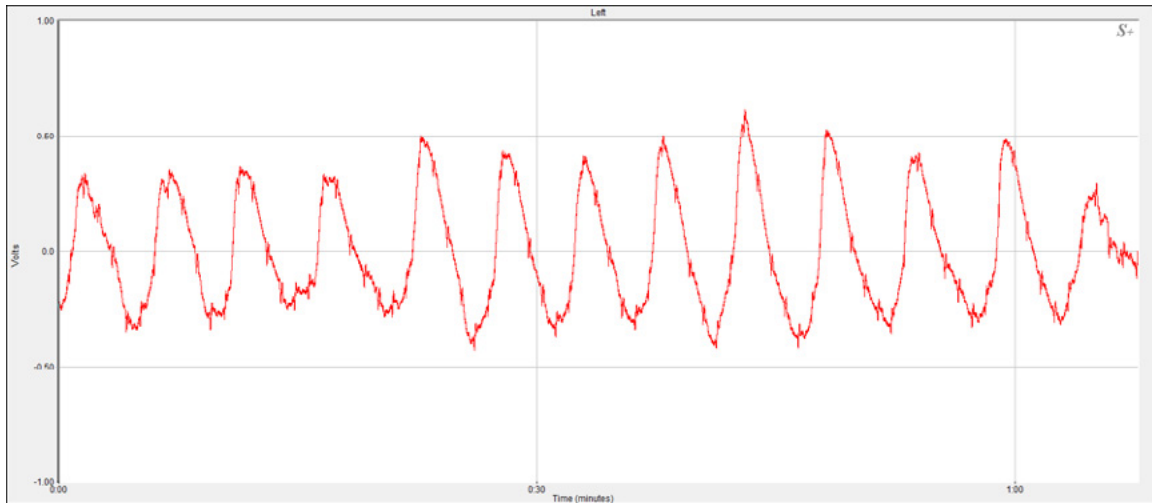

The trace above shows a time record approx 67s in length, with 13 breathing cycles evident. Low amplitude pulse signals can be seen superimposed on higher amplitude slow breathing cycles. Acquired using Piezo Film Lab Amp, charge mode, 10nF feedback capacitance, 0.1Hz LLF, 100kHz ULF, 0 dB gain. Sampled at 1kHz, 12bit resolution, +/- 1 V range. Note that the signal is bipolar (swings both positive and negative with respect to system ground).

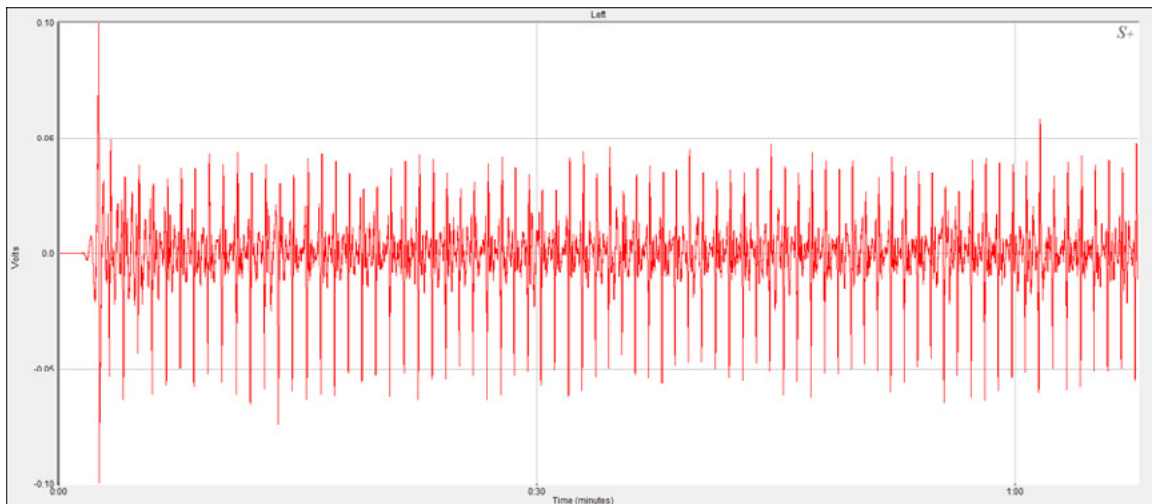

Same data as above, after applying a digital high-pass filter (2500 taps) at 2Hz. Now only the pulse signal is visible.

Example waveforms

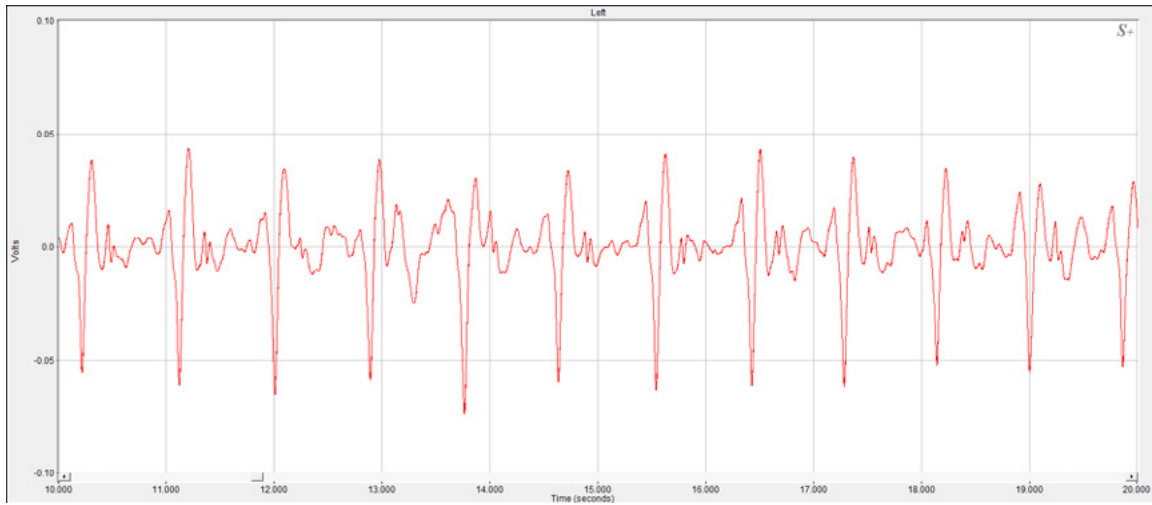

Zoom of 10-20s time interval, showing individual heartbeats, repeating at 1.1Hz (67bpm).

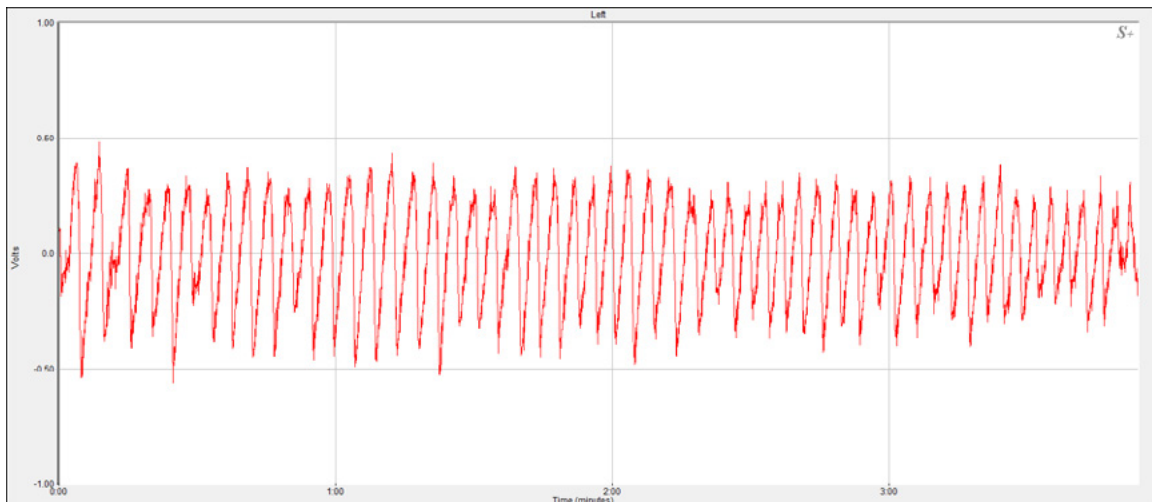

Above is a longer time record (234s duration), capturing approx 52 breathing cycles, using same instrumentation set-up as before but using 100Hz sampling rate. This record was analysed using FFT (Fast Fourier Transform), with 16K block size (averaged over 23377 data points), flattop window.

Example waveforms

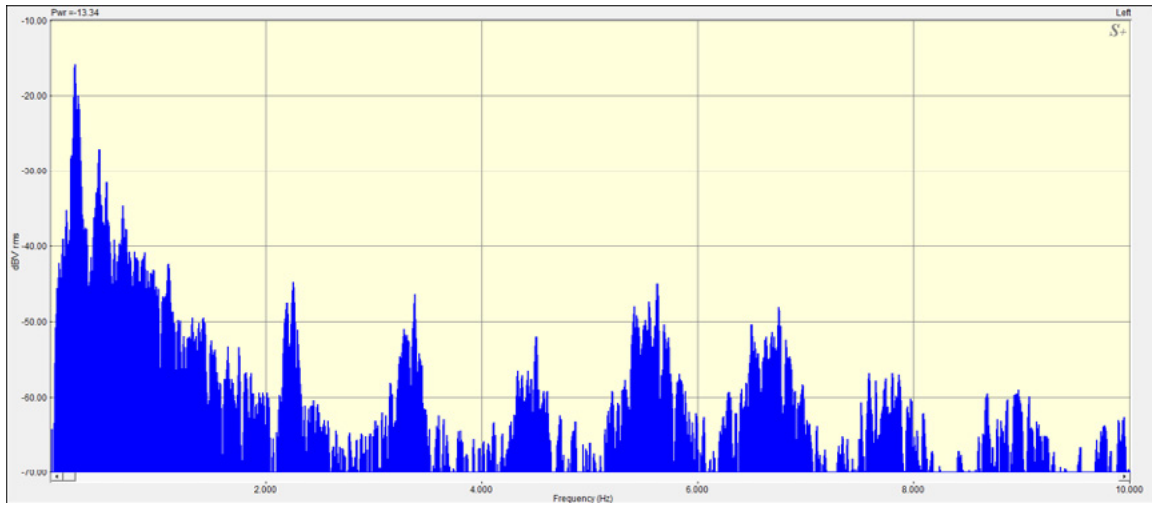

The spectral plot above is zoomed to show 0-10Hz span. Peak magnitude occurred at 0.226Hz (13.6breaths/minute). There is a small peak (barely visible) at 1.1Hz corresponding to average heart rate, with smeared harmonic groups at 2.2Hz, 3.3Hz, etc. It is clear from this plot that FFT processing of the raw data may not be suitable for extracting heart rate from the time signal.

Once again, digital high-pass filtering at 2Hz proved efficient at suppressing the breathing signal and revealing the heart rate.

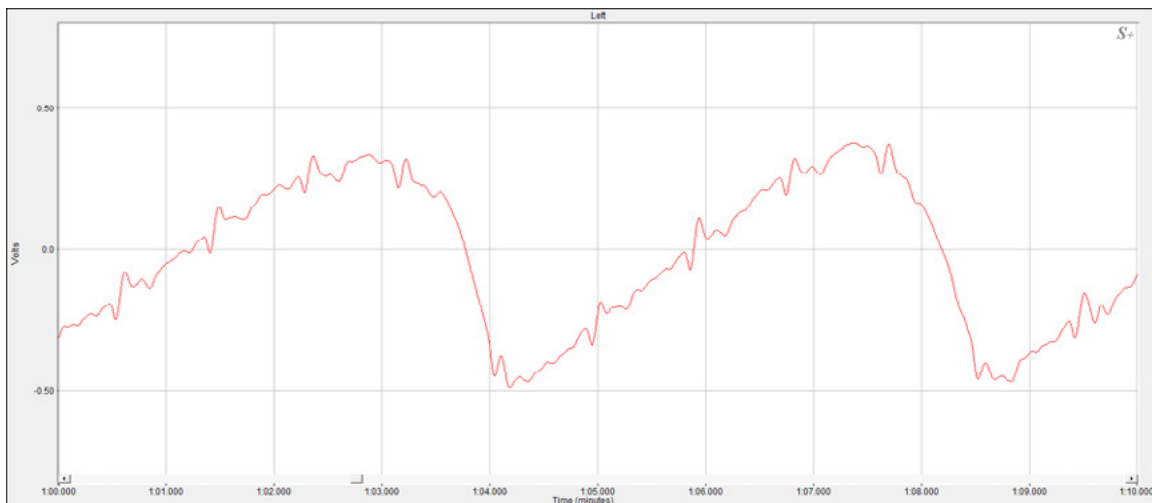

Zoom of raw data, 60-70s interval, showing breathing and pulse

SLEEP MONITOR STRIP

APPLICATION NOTE

Example waveforms

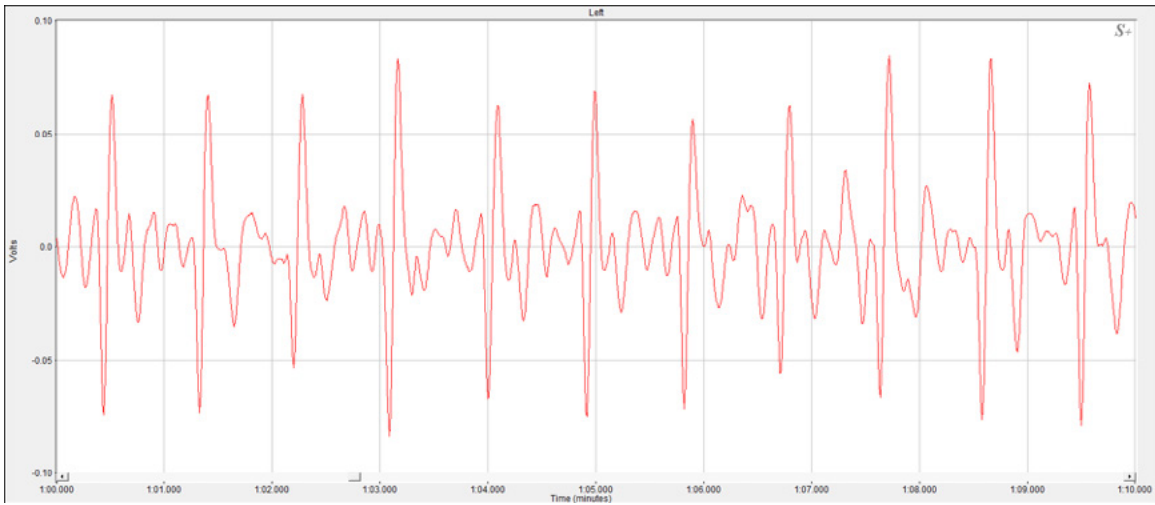

Zoom of high-pass filtered data, same 60-70s interval, showing only pulse

Dimensions

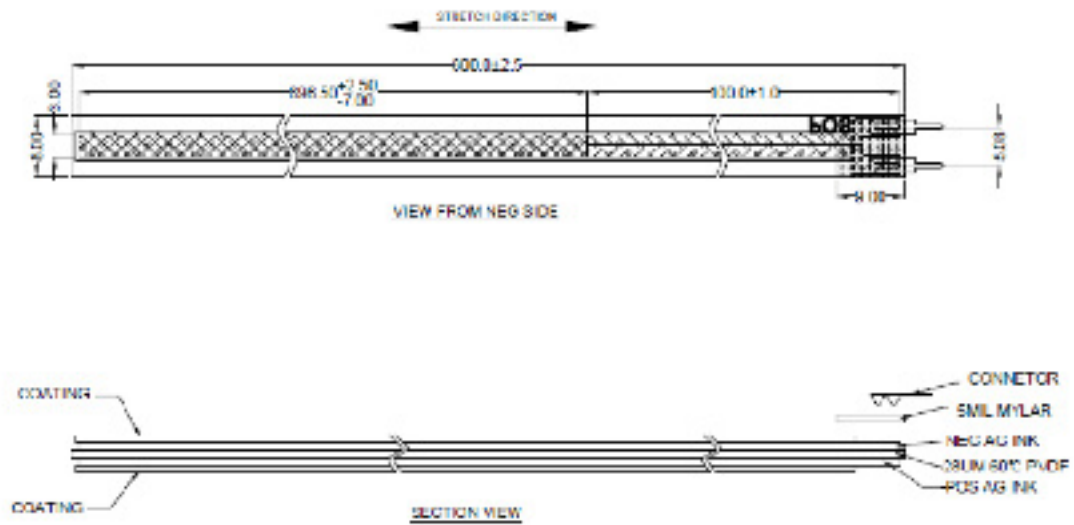

Ordering info

TE Part	
	# 10184000-01

Appendix A: Interface circuits – charge or voltage?

When monitoring signals from a piezoelectric source, we can choose whether to measure the charge (Q) generated, or the voltage (V). These quantities are directly related via the capacitance (C) of the sensor element (if nothing else is connected across the sensor), such that $Q = C.V$, or $V = Q/C$.

In a charge-mode design, the sensor is connected to a network that appears as a very low impedance, effectively a short-circuit, and the circuit maintains zero volts across the sensor terminals.

In a voltage-mode design, the sensor is connected to a network that presents a very high impedance, effectively an open-circuit, and no charge is removed from the sensor.

Either approach could be suitable for monitoring signals from the Sleep Monitor Strip, but there are certain advantages of a charge-mode design:

- In a charge-mode design, the sensor itself does not form part of the frequency-setting components
- Because the sensor element is effectively short-circuited, it is less affected by low-impedance paths that may form across the sensor (e.g. from moisture)
- It is easy to arrange signal gain within a single op-amp stage
- A T-network of resistors can be used within the feedback loop to “simulate” a very high value resistor

This note will give a brief overview of some outline schematics. In all cases, a generic op-amp with both +ve and -ve supply rails is assumed. The signal output of the Sleep Monitor Strip is fully bipolar. If a single power rail design is required, then a mid-rail “virtual ground” can be established using either a simple resistive divider, or using a divider buffered by another op-amp.

A1 Voltage mode, unity-gain buffer

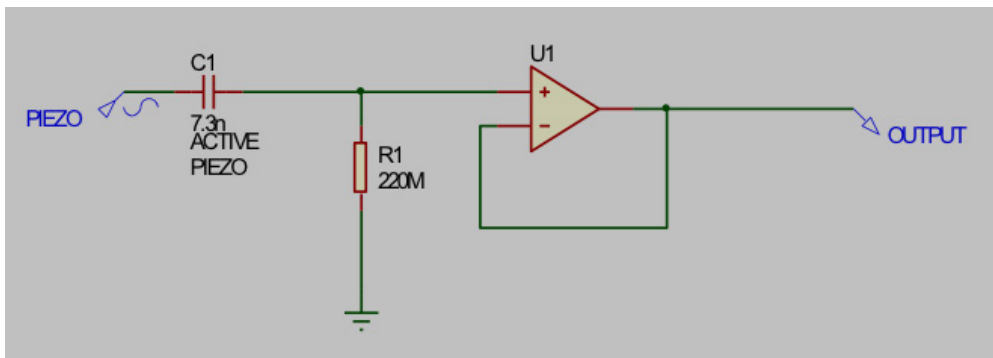

This design will give a lower limiting frequency (to -3dB) of 0.1Hz, assuming that the input resistance of the op-amp is much higher than R1. FET-input op-amps may have input R on the order of 1T ohm but other types may be significantly lower (e.g. 100M). This parameter must be checked before proceeding. Note that any low-impedance path across the sensor will effectively shunt R1 and may thus increase the lower limiting frequency (LLF).

A2

A2: Voltage mode, unity-gain buffer with input clamping diodes

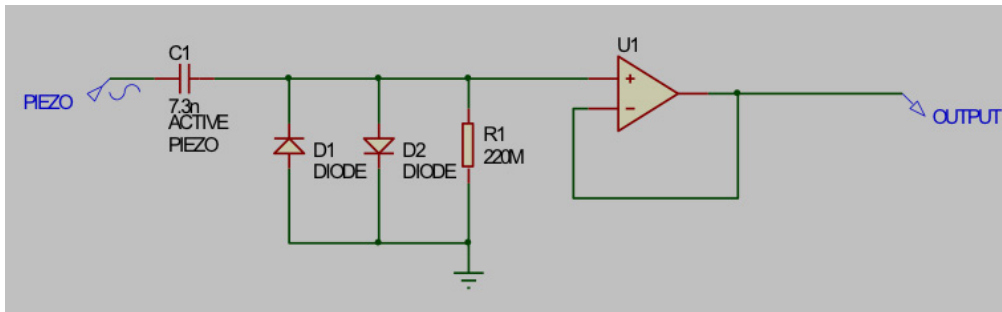

In this configuration, D1 and D2 will limit the final output voltage to approx 0.9V p-p (roughly the maximum continuous signal expected from breathing). Large transients from body movement will not cause saturation of the op-amp. Note, however, that once the diodes start to conduct, the smaller heartbeat signal may be lost as the signal is clipped. Here again, U1 must have sufficiently high input resistance ($\gg 220\text{M}$) to maintain the lower limiting frequency at 0.1Hz.

A3

A3: Voltage mode, inverting amplifier (unity gain)

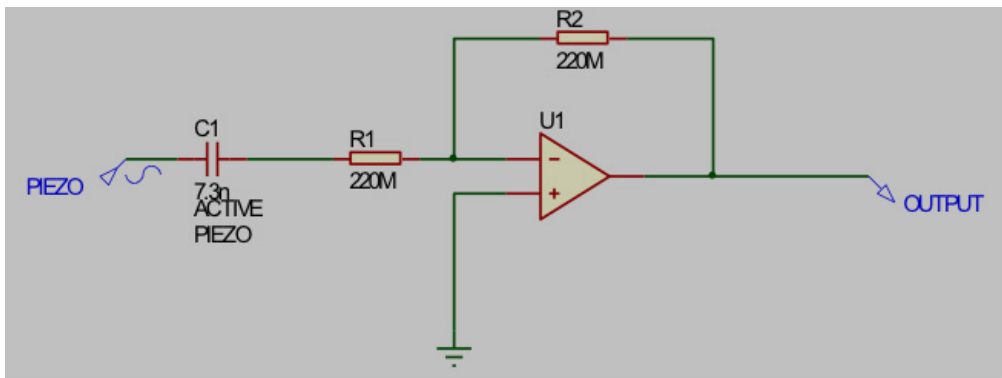

An advantage of this configuration is that the input resistance of the op-amp does not affect the lower limiting frequency, even if it is lower in value than R1. Selecting a higher value of R2 will add gain, as shown in the next example.

A4

A4: Voltage mode, inverting amplifier (with gain and limiting diodes)

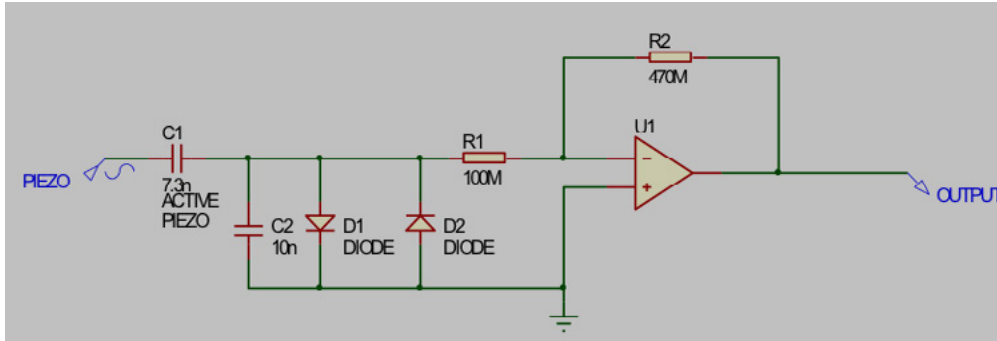

Here the sensor is initially shunted by a slightly larger capacitance value (C2), which attenuates the open-circuit signal. This allows more headroom for the breathing signal before meeting the action of the limiting diodes D1 and D2. R1 is adjusted downwards to maintain the same lower limiting frequency of 0.1 Hz with the increased input capacitance formed by C1 + C2. R2 then provides gain, to bring the final output to (max) 4.5 V p-p.

A5

A5: Charge mode, basic architecture, "unity gain"

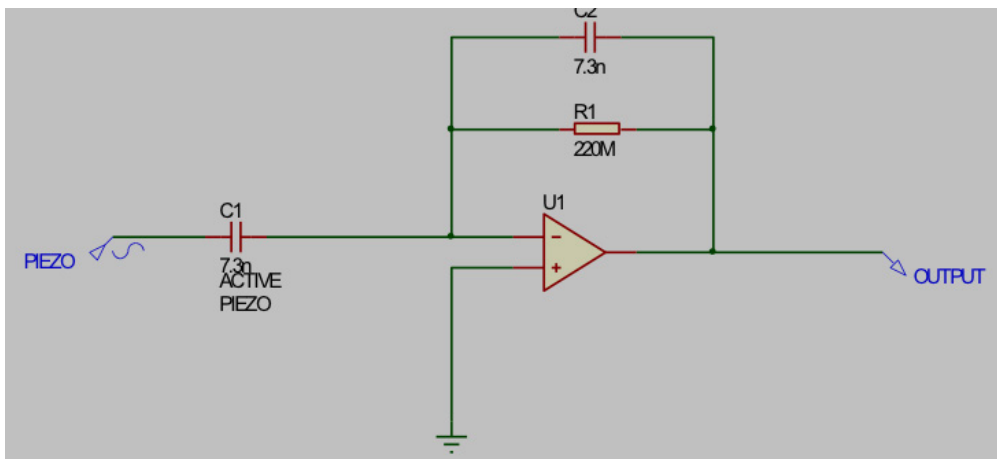

This is the simplest possible "charge amplifier" design. The sensor "sees" a dead short to ground, and all the source charge flows onto C2. R1 and C2 together determine the lower limiting frequency of the circuit, in this case 0.1Hz. The source capacitance C1 does not play any part in setting the LLF. The voltage across C1 is maintained at precisely zero. The input resistance of U1 does not influence the LLF. In this example, because C2 = C1, the final output voltage will be the same as the true open-circuit voltage produced by the sensor at frequencies above the LLF. To add "gain", we can decrease the value of C2 relative to C1, as shown in the next example.

A6: Charge mode, T network, "signal gain"

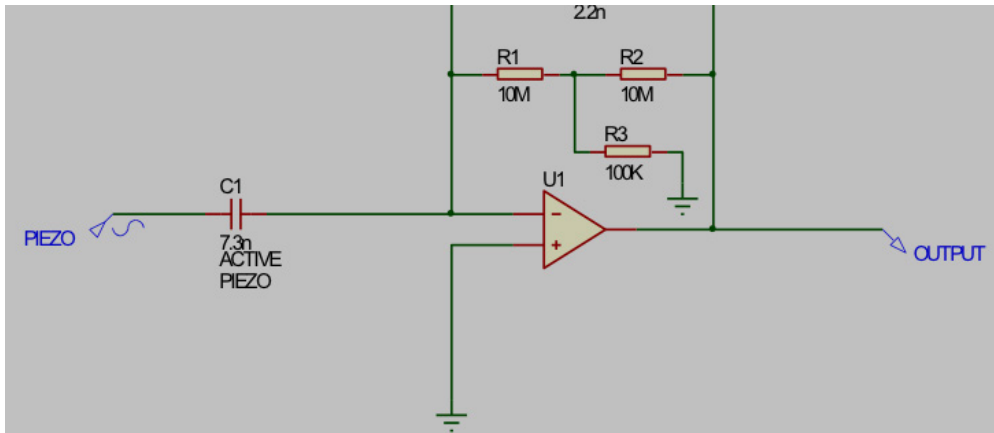

In this example, the effective "gain" is 3.3X, meaning that the output voltage (above the LLF) will be 3.3X greater than the true open-circuit voltage produced by the sensor. The combination of R1, R2 & R3 forms an equivalent much higher resistance value. In this case, the effective resistance value across C2 is given by $(R1 \times R2)/R3$, and is equal to 1 G. The lower limiting frequency is 0.07Hz.

A7: Charge mode, T network, "signal gain", with limiting diodes

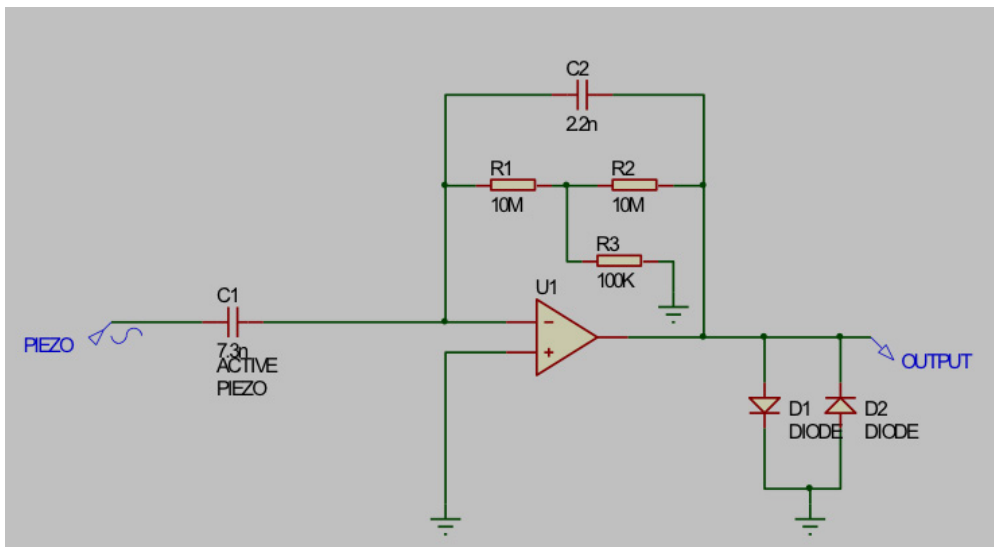

In the circuit of A5 above, it is not possible to include diode limiting across the sensor directly, as the voltage across the sensor is held at zero. If it is desired to prevent saturation of U1 for large input transients, then limiting diodes can be incorporated on the output side, as shown below. This arrangement will allow a maximum voltage swing of approx +/- 1.2 V

NORTH AMERICA

Measurement Specialties, Inc.
A TE Connectivity Company
Phone: +1 800-522-6752
Email: customercare.frmt@te.com

EUROPE

Measurement Specialties (Europe), Ltd.,
A TE Connectivity Company
Phone: +31 73-624-6999
Email: customercare.lcsb@te.com

ASIA

Measurement Specialties (China), Ltd.,
A TE Connectivity Company
Phone: +86 400-820-6015
Email: customercare.shzn@te.com

[TE.com/sensorsolutions](https://te.com/sensorsolutions)

Measurement Specialties, Inc., a TE Connectivity company.

Measurement Specialties, TE Connectivity, TE Connectivity (logo) and EVERY CONNECTION COUNTS are trademarks. All other logos, products and/or company names referred to herein might be trademarks of their respective owners.

The information given herein, including drawings, illustrations and schematics which are intended for illustration purposes only, is believed to be reliable. However, TE Connectivity makes no warranties as to its accuracy or completeness and disclaims any liability in connection with its use. TE Connectivity's obligations shall only be as set forth in TE Connectivity's Standard Terms and Conditions of Sale for this product and in no case will TE Connectivity be liable for any incidental, indirect or consequential damages arising out of the sale, resale, use or misuse of the product. Users of TE Connectivity products should make their own evaluation to determine the suitability of each such product for the specific application.

© 2019 TE Connectivity Ltd. family of companies All Rights Reserved.