

smiths connectors

# QUADSPLITTER AND IN-LINE QUADSPLITTER



## TECHNICAL CHARACTERISTICS

### SPECIFICATIONS

**Temperature Rating:** -55 °C to + 125 °C  
**Corrosion:** MIL-STD-202 Method 101, Test Condition B  
**Shock:** MIL-STD-202 Method 213, Test Condition B  
**Vibration:** MIL-STD-202 Method 204, Test Condition B  
**Thermal Shock:** MIL-STD-202 Method 107, Test Condition B  
**Durability:** 500 Mate/Unmate cycles/min.  
**Dielectric Withstand Voltage:** 250 VDC  
**Insulation Resistance:** 5.000 MegaOhms min  
**Contact Current Rating:** 3.0 Amps D.C. max.  
**Bandwidth:** Up to 3 Gigahertz  
**Data Rates:** Contacts designed to exceed 6 Gbps assembly dependent upon type and length of cable used  
**Differential Pair Cable Impedance:** 150 Ohm  $\pm$  15Ohm and 100 Ohm  $\pm$  10 Ohms  
**Signal to Shield Cable Impedance:** 75 Ohm  $\pm$  10 Ohm and 50 Ohm  $\pm$  7 Ohms

### MATERIALS AND FINISHES

**Shells & Inner Contacts:** Brass per ASTM-B16, alloy UNS C3600 or BeCU per ASTM-B196, alloy UNS C17200, C17300 or leaded nickel copper, alloy UNS C19500, C19600  
 Gold plate per MIL-DTL-45204 Type II, Class 1  
**Insulators:** PTFE per ASTM-D1710 or ULTERM 1000  
**Connector Plug/** Aluminum per ASTM-B211/221, 6061-T6  
**Receptacle Shells** Electroless nickel plate per SAE AMS-C-26074 or Cadmium plate per SAE AMS QQ-P-416  
**Gasket/Seal** Silicone rubber per A-A-59588

# QUADSPLITTER

- ▶ **Fibre Channel**
- ▶ **Ethernet: 10 Base-T, 100 Base-T, 1000 Base-T**
- ▶ **Firewire: IEEE 1394a and 1394b**
- ▶ **USB, DVII, HDMI and Infiniband**

Smiths Connectors offers a complete line of differential Twinax and Quadrx connectors, contacts and cable assemblies for high speed Ethernet, Firewire, and Fibre Channel applications. Differential pair quadrx and twinax connectors and cable assemblies offer superior performance in high speed matched impedance data-on-demand applications. The signal to signal and signal to shield characteristic impedance is maintained throughout the connector pair. A true twinaxial connector interface ensures signal integrity while minimizing jitter and data rate errors.

#### Testing Capabilities

Smiths Connectors Quadrx and Twinax interconnects are characterized for testing eye pattern, jitter, skew, and insertion loss on differential pair 100 ohm high speed Gigabit Ethernet applications with a wide variety of testing protocols. We utilize the Agilent E5071C 4 port network analyzer to measure the differential pair TDR impedance between Twinax connectors, cable assemblies, and quad cable Ethernet and Fibre Channel interconnect systems ensuring the most accurate acquired signal for high speed communications testing. The E5071C 4 port network analyzer is capable of highly accurate 100 Ohm differential measurements up to 20 GHz and can measure Eye Diagrams up to 16 Gbps.



# TABLE OF CONTENTS

IN-LINE QUADSPLITTER .....	4
▶ Technical characteristics .....	4
QUADSPLITTER.....	5
▶ Technical characteristics .....	5
▶ Cable Assembly Ordering .....	7

Smiths Connectors is now able to offer the best of both worlds with our In-Line Quadsplitter which offers another solution for extending the distance that High Speed signals can be sent over a Quadrax architecture. We can combine the signal integrity of Twinax cables and the connection density of Quadrax contacts by incorporating two 26 AWG Twinax cables into a standard Size 8 Quadrax contact. The resulting cable assembly is about the same size and weight as a 24 AWG Quadrax cable assembly and offers the same flexibility and ease of use.

The In-Line Quadsplitter can be used alone or in conjunction with the In-Line Equalizer. Many customers prefer the connection density and ease of use of Quadrax cables and connectors. Quadrax cables are limited in performance at higher data rates being used today due to the orthogonal construction of the quadrax cable due to crosstalk. Higher losses and frequency drop outs may adversely affect the integrity of the signal as compared to Twinax cables of similar size and construction.

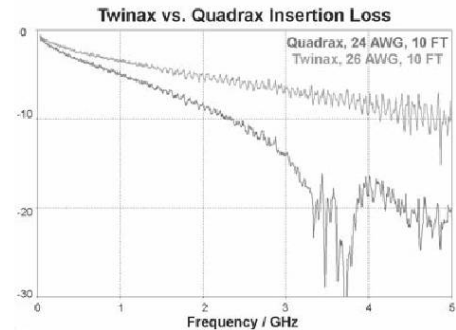

▶ **TYPICAL IN-LINE EQUALIZER AND/OR QUADSPLITTER PACKAGING IN SIZE 8 QUADRIX CONTACT**

\*Patent Pending

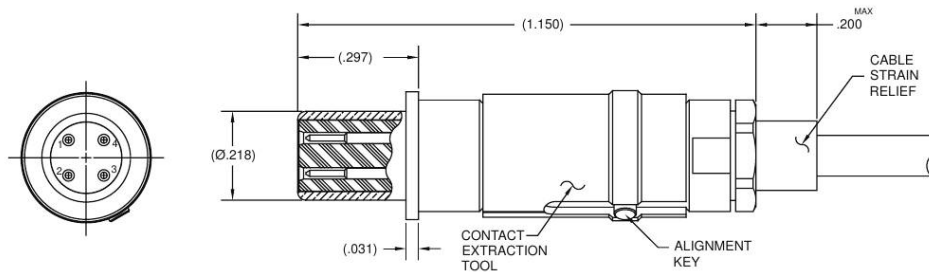

CONTACT TYPE	PART NUMBER	CABLE TYPE	CABLE	SIZE
Equalizer	<b>019635-8027</b>	Differential Quad	540-1183-000	24 AWG
Quadsplitter	<b>019635-8030</b>	Differential Twinax	540-1153-000	26 AWG

\*Please consult factory for additional cable types and contact configurations.  
All connector formats are available for pin/socket Quadrax and Twinax contacts.

Currently high-speed data transference requires transmission systems that minimize reflections. This is achieved through controlled characteristic impedance from source to load. In microwave systems, this is accomplished with waveguide or coaxial transmission lines. In both cases, the line geometry is the determining factor along with dielectric and conductor materials. Steps, bends, protrusions etc. will invariably cause reflections with consequent loss of transmission efficiency. In 2-wire differential-mode transmissions this is acceptable at lower data rates, however, when data rates become higher, such as fibre channel (into microwave frequencies), the line characteristic impedances become much more critical.

In fibre channel systems the source and load differential impedances are usually high (100 -150 ohm). Achieving these high impedances in coaxial transmission lines and connectors is size prohibitive. As a result, a line configuration such as twinax where the signals carried between a pair of conductors (usually round) critically spaced from each other and surrounded by a conductive enclosure is used. In this "differential line" high impedances are easily obtained since the mutual capacitance between the conductors is minimized.

A more efficient development for fibre channel transmission is the "Quadrax", a single enclosure with four wires where a diagonal pair of conductors forms a twinax differential pair.

A problem arises when the Quadrax to Twinax conversion takes place and the channels must be physically separated. The

diagonal pairs will cross over resulting in impedance disturbance and reflection with some crosstalk. At low frequencies or data rates, this is somewhat manageable, however when data rates approach microwave frequencies the resulting system degradation becomes unacceptable. This problem is effectively overcome by employment of stripline or microstrip transmissions.

The unique feature of this method is the placement of the traces and ground planes within a stack of circuit boards where the lines from the quadrax input contact pins couple straight onto the stripline traces without crossing over or disturbing the relative positions of the selected diagonal pairs. This means the impedance is relatively consistent and therefore not frequency sensitive.

Referring to the assembly and circuit boards below, it can be seen that by locating a common ground plane between two trace layers, the signal pairs will be isolated and in the controlled impedance of effectively two separate transmission systems. In the above case, the separated pairs run to surface pads that, thru selected plated-thru holes, connect to the assigned embedded traces. Note the diagonal pairs from the Quadrax interface are attached to the pads on their assigned traces, while merely passing through the board with traces and pads belonging to the other diagonal pair. The paired traces are routed to the board edge case, and will be soldered to the separated twinax cables. The chart below is a differential TDR showing the impedance in the transition region.

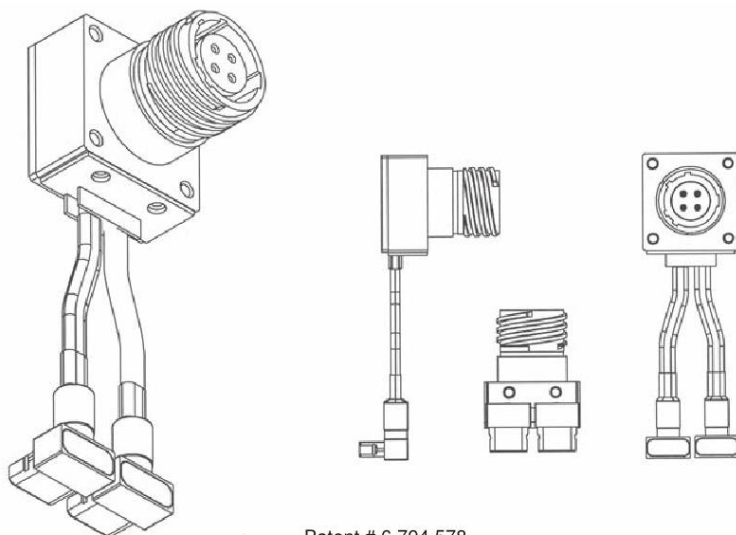

Patent # 6,794,578

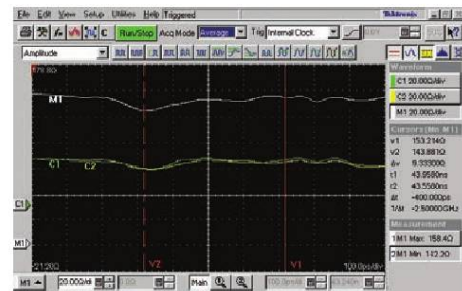

TDR Traces

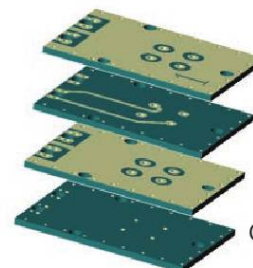

Circuit Boards

► **SIZE 11 QUAD RECEPTACLE TO 2 SOCKET INSERT RIGHT ANGLE TWINAX CABLES TO OPEN LEAD**

Y	Polarization
1	N
2	A
3	B
4	C
5	D
6	E

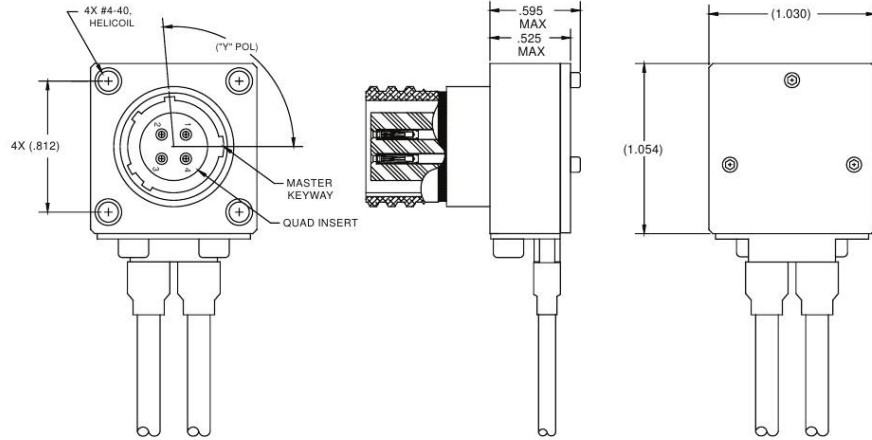

Please specify cable length when ordering

PART NUMBER	CABLE TYPE	CABLE
<b>02990Y-0100</b>	Differential Twinax	540-1099-000

Y = Connector Polarization

► **SIZE 25 FOUR WAY QUAD PIN INSERT RECEPTACLE TO 8 RIGHT ANGLE TWINAX CABLES TO OPEN LEAD**

Y	Polarization
1	N
2	A
3	B
4	C
5	D
6	E

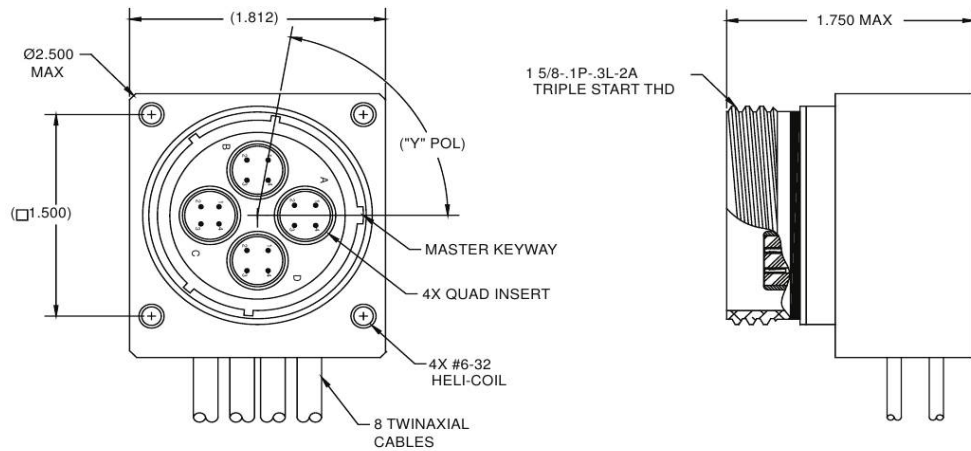

Please specify cable length when ordering

PART NUMBER	CABLE TYPE	CABLE
<b>01370Y-3000</b>	Differential Twinax	540-1099-000

Y = Connector Polarization

## HOW TO ORDER



### 1 ▶ CONNECTOR #1

### 2 ▶ CABLE GROUP #

Flexible Twinax

- 1** = M17/176-00002
- 2** = 540-1086-000
- 3** = 540-1161-000

Differential Twinax

- 6** = 540-1099-000
- 7** = 540-1114-000
- 8** = 540-1153-000
- 34** = 540-1167-000
- 38** = 540-1210-000
- 39** = 540-1236-000

Differential Quadrax

- 9** = 540-1138-000
- 10** = 540-1143-000
- 36** = 540-1183-000
- 37** = 540-1235-000
- 42** = 540-1209-000
- 41** = 540-1229-000

### 3 ▶ CONNECTOR #2      OL for Open Lead

### 4 ▶ CABLE LENGTH IN INCHES (XXX)

FLEXIBLE TWINAX CABLES				
CABLE GROUP	CABLE DESIGNATION	IMPEDANCE (OHMS)	JACKET	CONDUCTOR (DIA)
1	M17/176-00002	77	0.129"	0.024"
2	540-1086-000	98	0.143"	0.019"
3	540-1161-000	100	0.130"	0.024"
DIFFERENTIAL PAIR TWINAX CABLES				
6	540-1099-000	Differential: 150 Sig. to Shield: 75	0.097" x 0.160"	0.014" Stranded
7	540-1114-000	Differential: 150 Sig. to Shield: 75	0.138" x 0.224"	0.020" Solid
8	540-1153-000	Differential: 100 Sig. to Shield: 50	0.085" x 0.130"	0.019" Stranded
34	540-1167-000	Differential: 100 Sig. to Shield: 50	0.117" x 0.160"	0.0233" Stranded
38	540-1210-000	Differential: 100 Sig. to Shield: 50	0.132"	0.019"
39	540-1236-000	Differential: 150 Sig. to Shield: 75	0.191"	0.019"
DIFFERENTIAL QUADRAX CABLES				
9	540-1138-000	Differential: 150 Sig. to Shield: 75	0.290"	0.032"
10	540-1143-000	Differential: 150 Sig. to Shield: 75	0.190"	0.020"
36	540-1183-000	Differential: 100 Sig. to Shield: 50	0.160"	0.024"
37	540-1235-000	Differential: 100 Sig. to Shield: 50	0.108"	0.012"
40	540-1209-000	Differential: 100 Sig. to Shield: 50	0.190"	0.029"
41	540-1229-000	Differential: 100 Sig. to Shield: 50	0.137"	0.019"



# SMITHS CONNECTORS GLOBAL SUPPORT

## AMERICAS

[info.us@smithsconnectors.com](mailto:info.us@smithsconnectors.com)

**Costa Mesa, CA**  
1.714.371.1100

**Hudson, MA**  
1.978.568.0451

**Kansas City, KS**  
1.913.342.5544

## EUROPE

### France

33.2.32969176  
[info.fr@smithsconnectors.com](mailto:info.fr@smithsconnectors.com)

### Germany

49.991.250.120  
[info.de@smithsconnectors.com](mailto:info.de@smithsconnectors.com)

### Italy

39.010.60361  
[info.it@smithsconnectors.com](mailto:info.it@smithsconnectors.com)

### United Kingdom

44.208.236.2400  
[info.uk@smithsconnectors.com](mailto:info.uk@smithsconnectors.com)

## ASIA

[asiainfo@smithsconnectors.com](mailto:asiainfo@smithsconnectors.com)

**Shanghai, China**  
86.21.3318.4650

**Suzhou, China**  
86.512.6273.1188

**Singapore**  
65.6846.1655

visit us at | [smithsconnectors.com](http://smithsconnectors.com) |     