

L Series

Rugged High Density Modular Connectors



Hyperboloid Technology

Smiths Interconnect offers an extensive range of superior contact technologies suitable for standard and custom solutions. Hypertac® (HYPERboloid conTACT) is the original superior performing hyperboloid contact technology designed for use in all applications and in harsh and demanding environments where high reliability and safety are critical. The inherent electrical and mechanical characteristics of the Hypertac hyperboloid contact ensures unrivalled performance in terms of reliability, number of mating cycles, low contact force and minimal contact resistance. The contact sleeve is formed by wires, in a hyperboloid geometry, which align themselves elastically as contact lines around the pin, providing a number of linear contact paths.

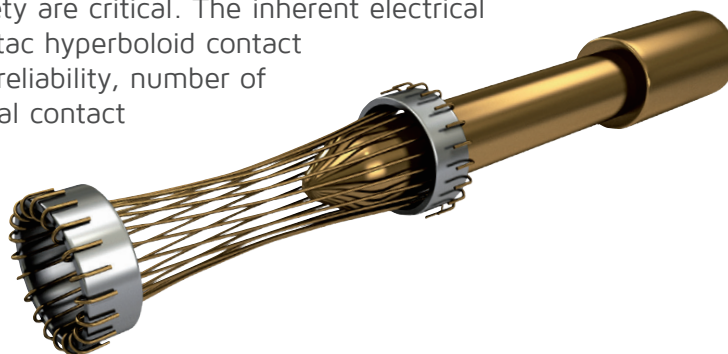

Features

Low insertion/extraction forces

The angle of the socket wires allows tight control of the pin insertion and extraction forces. The spring wires are smoothly deflected to make line contact with the pin.

Long contact life

The smooth and light wiping action minimizes wear on the contact surfaces. Contacts perform up to 100,000 insertion/extraction cycles with minimal degradation in performance.

Lower contact resistance

The design provides a far greater contact area and the wiping action of the wires insures a clean and polished contact surface. Our contact technology has about half the resistance of conventional contact designs.

Higher current ratings

The design parameters of the contact (e.g., the number, diameter and angle of the wires) may be modified for any requirement. The number of wires can be increased so the contact area is distributed over a larger surface. Thus, the high current carried by each wire because of its intimate line contact, can be multiplied many times.

Immunity to shock & vibration

The low mass and resultant low inertia of the wires enable them to follow the most abrupt or extreme excursions of the pin without loss of contact. The contact area extends 360° around the pin and is uniform over its entire length. The 3 dimensional symmetry of the Hypertac contact design guarantees electrical continuity in all circumstances.

Benefits

High density interconnect systems

Significant reductions in size and weight of sub-system designs. No additional hardware is required to overcome mating and un-mating forces.

Low cost of ownership

The Hypertac contact technology will surpass most product requirements, thus eliminating the burden and cost of having to replace the connector or the entire subsystem.

Low power consumption

The lower contact resistance of our technology results in a lower voltage drop across the connector reducing the power consumption and heat generation within the system.

Maximum contact performance

The lower contact resistance of the Hypertac contact reduces heat build-up; therefore Hypertac contacts are able to handle far greater current in smaller contact assemblies without the detrimental effects of high temperature.

Reliability under harsh environments

Harsh environmental conditions require connectors that will sustain their electrical integrity even under the most demanding conditions such as shock and vibration. The Hypertac contact provides unmatched stability in demanding environments when failure is not an option.

Contents

L Series	4
Features & Benefits	4
How to Order	5
Frames:	
Frame A - Rack & Panel.....	6
Frame B - Rack & Panel with Guides.....	7
Frame BV - Jackscrew mating.....	8
Frame H - Float Mounting for Blind Mating	9
Frame J - Latching Metal Backshell.....	10
Frame JV - Jackscrew with Metal Backshell.....	11
Frame MV - Jackscrew with Plastic Backshell.....	12
Frame MY - Half-Turn Jackscrew with Plastic Backshell.....	13
Modules:	
Technical Characteristics	14
Accessories	15
Module A - 5x Fixed 8Amp Contacts	16
Module R - 5x Snap-in 8Amp Crimp Contacts.....	17
Module B - 3x Fixed 15Amp Contacts.....	18
Module S - 3x Snap-in 15Amp Crimp Contacts	19
Module C & M - 2x Fixed 25 or 50Amp Contacts.....	20
Module U - 2x Snap-in 25 or 50Amp Crimp Contacts	21
Module D - 17x Fixed 8Amp Contacts.....	22
Module W - 30x Removable 4Amp Contacts	23
Module V Power - 3x Removable 25Amp Crimp Contacts.....	24
Module V Coax - 3x Removable Coaxial Contacts.....	25
Module G - 1x Removable 200Amp Crimp Contact	26
Module K - 1x Removable 100Amp Crimp Contact.....	27
Module F - 2x Butt Joint Fiber Optic Contacts and 1x Coaxial (or 1x 25Amp) Contact	28
Module PN - 2x Pneumatic Contacts	29
 Mounting Dimensions	 30

L Series Connectors

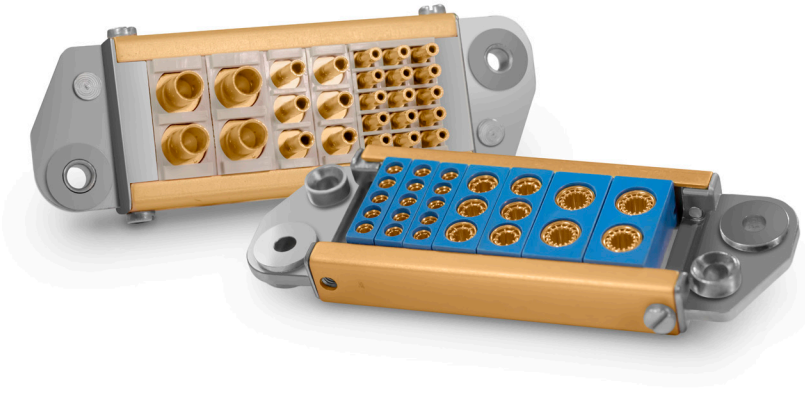

Smiths Interconnect's L Series rugged high density modular connectors employ a do-it-yourself system based on the principle of building blocks. The L Series system is composed of two elements: modules and frames. Modules of various styles and contact types, including signal, power and coaxial, can be combined into custom arrangements within a single connector frame. This allows the user to build a connector that addresses and fulfils their exact requirements with off-the-shelf components.

Ideal for rugged rack & panel applications, L Series connectors utilize the unparalleled performance of Hypertac® hyperboloid contact technology to provide high cycle life, low insertion/extraction forces and immunity to shock and vibration. This ensures smooth and easy mating with maximum performance in connectors with numerous contacts.

The contacts are mounted in small plastic blocks and are removable for easy assembly and repair. The frames which hold the modules in position range from basic, consisting of two side rails and end caps, to more complex, including Jackscrews, hoods and cable clamps. To conform to almost any combination of modules, all frames are available in numerous lengths. With the L Series, specially designed connectors can be purchased quickly and inexpensively, eliminating the need for custom tooling.

Features and Benefits

Low insertion / extraction forces

High density interconnect systems

Reliability in harsh environments

- Immune to shock and vibration
- Long contact life
- Minimal contact resistance
- Efficient power consumption

High current ratings

Low cost of ownership

Design flexibility

- Metal back shells / plastic hoods
- Building block system composed of custom module combinations within a connector frame
- Signal, power and coaxial contact types available
- Fixed and snap-in contact versions
- Jackscrews available for half-turn quick disconnect
- Float mounting for blind mate

Cable to chassis and rack & panel applications

Fixed Contacts

Module	Contacts	Current Rating
Type A	5	8 A
Type B	3	15 A
Type C	2	25 A
Type D	17	8 A
Type M	2	50 A

Snap-In Crimp Contacts

Module	Contacts	Current Rating
Type G	1	200 A
Type K	1	100 A
Type R	5	8 A
Type S	3	15 A
Type U	2	25 & 50 A
Type V	3	25 A
Type V	3 Coaxial	—
Type W	30	4 A

How To Order



1 L Series [Fixed] ¹	
2 Plug or Receptacle	P Plug E Receptacle
3 Frame Type	A Frame A B Frame B BV Frame BV H Frame H J Frame J JV Frame JV MV Frame MV MY Frame MY
4 Frame Length	4 to 20 Units ⁽²⁾ Frame length is computed by multiplying the module units by module quantity and totaling the results. Allow 2 additional units for frames with jackscrews (see BV, BY, JV, MV, and MY frames).
5 Module Quantity + Part Number	4 + AMST 2 + CHT Amount of same modules together within frame. (Drop "L" from beginning of module part number, see pages 16 thru 27 for all module part numbers). Example: 4AMST = 4 of the (L)AMST style modules. Separate each series of modules by "/". Modules will be positioned in frame according to sequence listed.
6 Plating	TG 10 µin Gold over Nickel (pins only) TH 50 µin Gold over Nickel (pins only) TAH 50 µin Gold over Nickel on socket wires, gold flash on termination (sockets only)
7 Cable Clamp and Size ⁽³⁾ (J & JV frames only)	SC10 0.394 [10.00] Max, 0.210 [5.35] Min SC15 0.590 [15.00] Max, 0.385 [9.75] Min SC20 0.787 [20.00] Max, 0.605 [15.25] Min SC24 0.945 [24.00] Max, 0.670 [17.00] Min
8 Cable Clamp Location (J & JV Frames Only)	L Left* R Right* F Front B Back Omit for default location. (J/JV: Top) *JV frame only

Notes: 1. If part number exceeds 24 characters, a special abbreviated part number will be assigned at the time of order. 2. Frames MV and MY available in 12, 15, 20 and 22 units only. 3. May be some limitations on cable clamp size in connectors of shorter length. Dimensions are in inches [mm].

Frames

Dimensions and Specifications

Frame A

Simple Rack & Panel

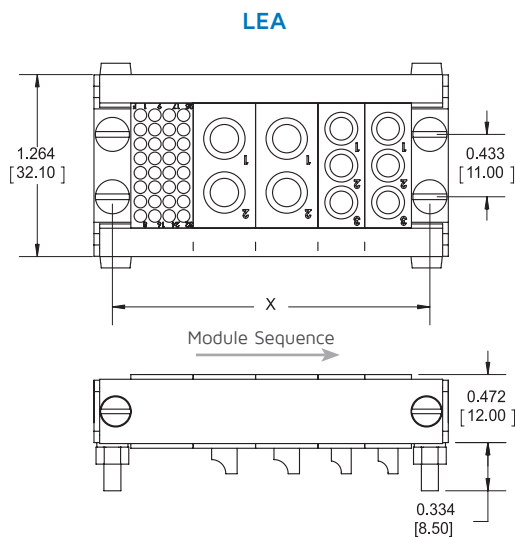
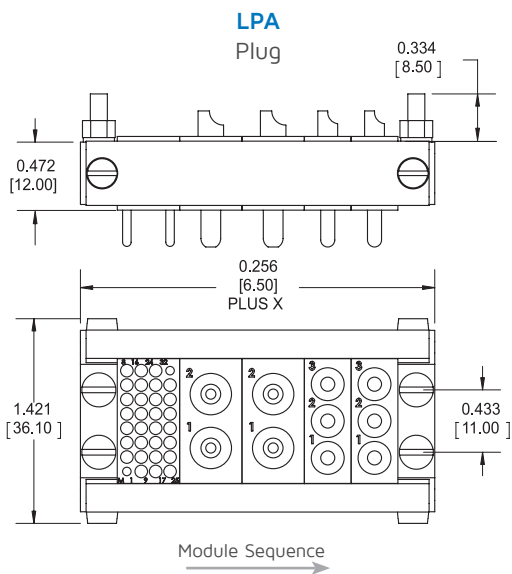
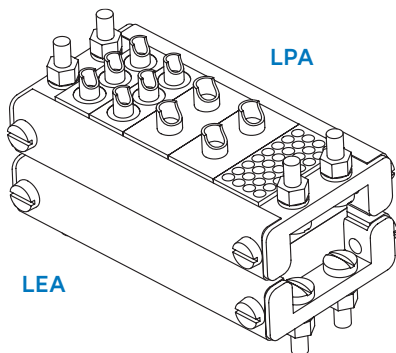

Units	X	Plug	Receptacle
4	1.122 [28.50]	LPA4	LEA4
5	1.338 [34.00]	LPA5	LEA5
6	1.555 [39.50]	LPA6	LEA6
7	1.771 [45.00]	LPA7	LEA7
8	1.988 [50.50]	LPA8	LEA8
9	2.205 [56.00]	LPA9	LEA9
10	2.421 [61.50]	LPA10	LEA10
11	2.638 [67.00]	LPA11	LEA11
12	2.854 [72.50]	LPA12	LEA12
13	3.070 [78.00]	LPA13	LEA13
14	3.287 [83.50]	LPA14	LEA14
15	3.504 [89.00]	LPA15	LEA15
16	3.720 [94.50]	LPA16	LEA16
17	3.936 [100.00]	LPA17	LEA17
18	4.153 [105.50]	LPA18	LEA18
19	4.370 [111.00]	LPA19	LEA19
20	4.586 [116.50]	LPA20	LEA20

Weight (Excluding Modules)	
A Plug	1.0 oz. at 4 units 1.9 oz. at 20 units
A Receptacle	1.0 oz. at 4 units 1.9 oz. at 20 units

Frame B

Simple Rack & Panel with Guides

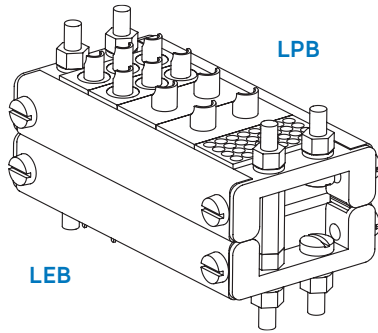

Units	X	Plug	Receptacle
4	1.122 [28.50]	LPB4	LEB4
5	1.338 [34.00]	LPB5	LEB5
6	1.555 [39.50]	LPB6	LEB6
7	1.771 [45.00]	LPB7	LEB7
8	1.988 [50.50]	LPB8	LEB8
9	2.205 [56.00]	LPB9	LEB9
10	2.421 [61.50]	LPB10	LEB10
11	2.638 [67.00]	LPB11	LEB11
12	2.854 [72.50]	LPB12	LEB12
13	3.070 [78.00]	LPB13	LEB13
14	3.287 [83.50]	LPB14	LEB14
15	3.504 [89.00]	LPB15	LEB15
16	3.720 [94.50]	LPB16	LEB16
17	3.936 [100.00]	LPB17	LEB17
18	4.153 [105.50]	LPB18	LEB18
19	4.370 [111.00]	LPB19	LEB19
20	4.586 [116.50]	LPB20	LEB20

Weight (Excluding Modules)	
B Plug	1.0 oz. at 4 units 1.9 oz. at 20 units
B Receptacle	1.0 oz. at 4 units 1.9 oz. at 20 units

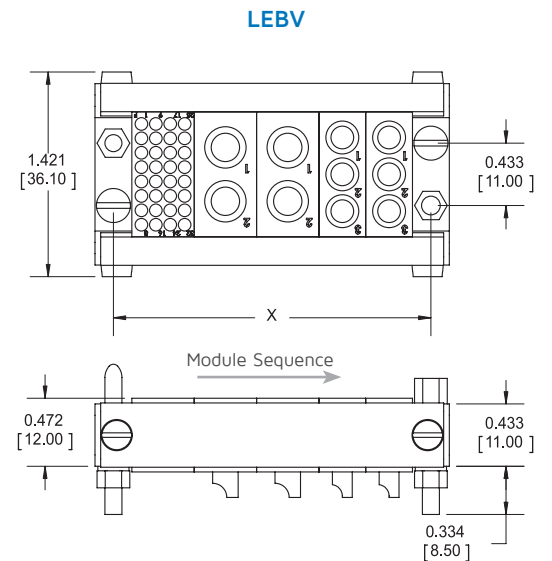
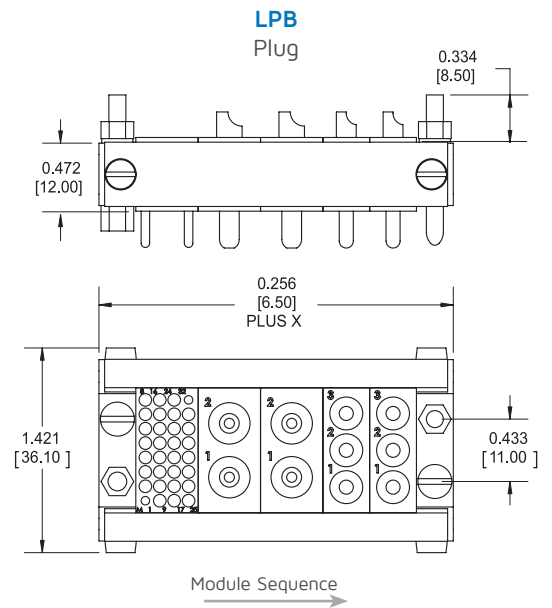

Frame BV

Rack & Panel with Guides & Jackscrew

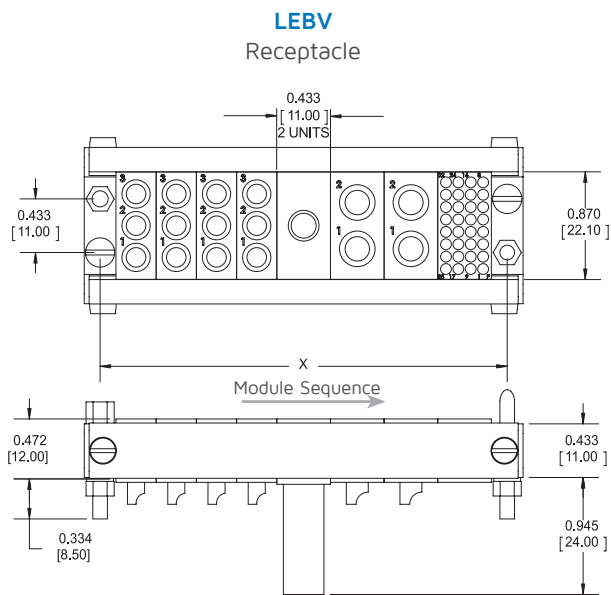
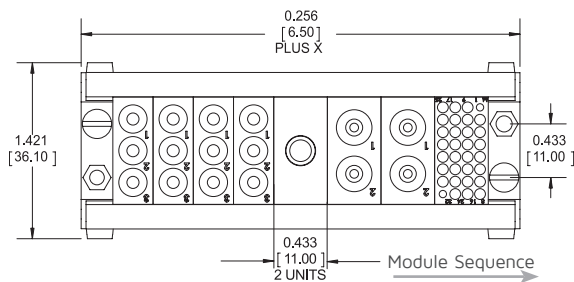
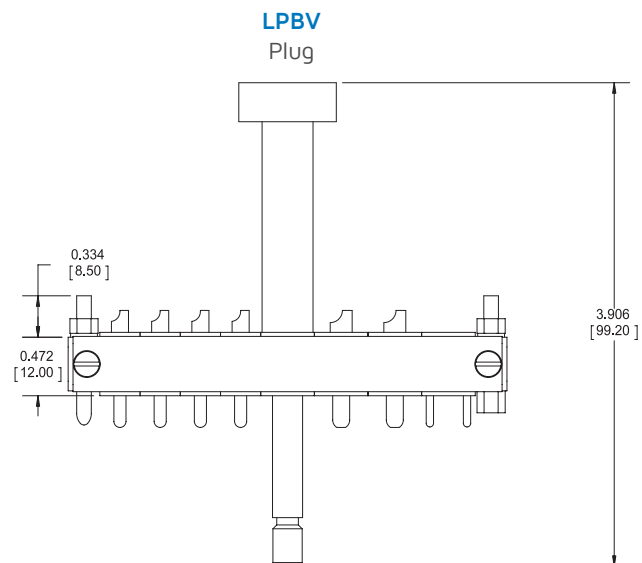
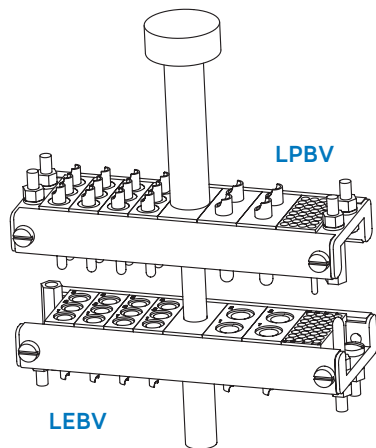

Units	X	Plug	Receptacle
4	1.122 [28.50]	LPBV4	LEBV4
5	1.338 [34.00]	LPBV5	LEBV5
6	1.555 [39.50]	LPBV6	LEBV6
7	1.771 [45.00]	LPBV7	LEBV7
8	1.988 [50.50]	LPBV8	LEBV8
9	2.205 [56.00]	LPBV9	LEBV9
10	2.421 [61.50]	LPBV10	LEBV10
11	2.638 [67.00]	LPBV11	LEBV11
12	2.854 [72.50]	LPBV12	LEBV12
13	3.070 [78.00]	LPBV13	LEBV13
14	3.287 [83.50]	LPBV14	LEBV14
15	3.504 [89.00]	LPBV15	LEBV15
16	3.720 [94.50]	LPBV16	LEBV16
17	3.936 [100.00]	LPBV17	LEBV17
18	4.153 [105.50]	LPBV18	LEBV18
19	4.370 [111.00]	LPBV19	LEBV19
20	4.586 [116.50]	LPBV20	LEBV20

Weight (Excluding Modules)	
BV Plug	4.7 oz. at 4 units 5.6 oz. at 20 units
BV Receptacle	2.5 oz. at 4 units 3.4 oz. at 20 units

Frame H

Float Mount Rack & Panel with Guides

Float mounting 0.049 [1.25]¹ max. from center

 File No.: UL E102195

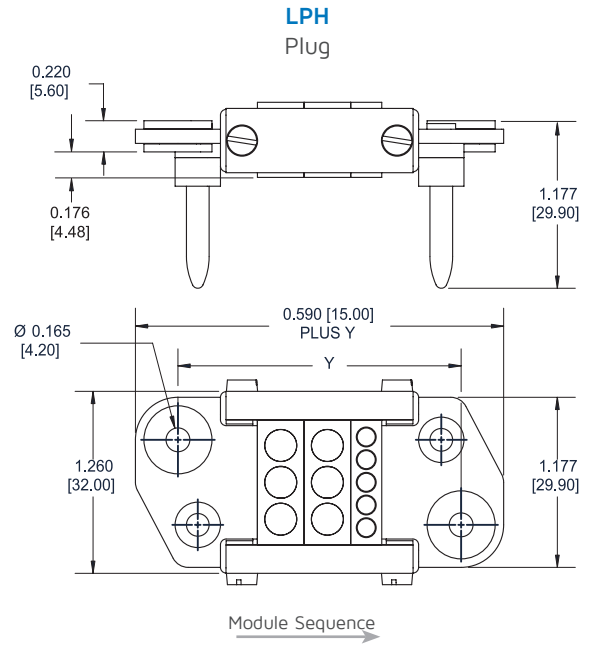
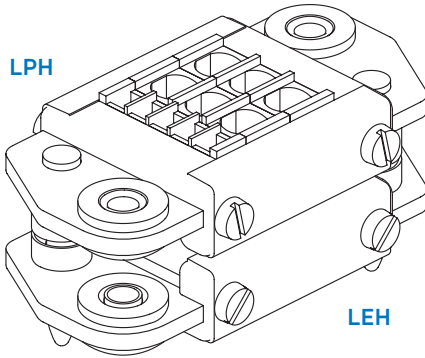

Units	Y	Plug	Receptacle
4	1.969 [50.00]	LPH4	LEH4
5	2.185 [55.50]	LPH5	LEH5
6	2.402 [61.00]	LPH6	LEH6
7	2.618 [66.50]	LPH7	LEH7
8	2.835 [72.00]	LPH8	LEH8
9	3.051 [77.50]	LPH9	LEH9
10	3.268 [83.00]	LPH10	LEH10
11	3.484 [88.50]	LPH11	LEH11
12	3.701 [94.00]	LPH12	LEH12
13	3.917 [99.50]	LPH13	LEH13
14	4.134 [105.00]	LPH14	LEH14
15	4.350 [110.50]	LPH15	LEH15
16	4.567 [116.00]	LPH16	LEH16
17	4.784 [121.50]	LPH17	LEH17
18	5.00 [127.00]	LPH18	LEH18
19	5.217 [132.50]	LPH19	LEH19
20	5.433 [138.00]	LPH20	LEH20
21	5.650 [143.50]	LPH21	LEH21
22	5.866 [149.00]	LPH22	LEH22

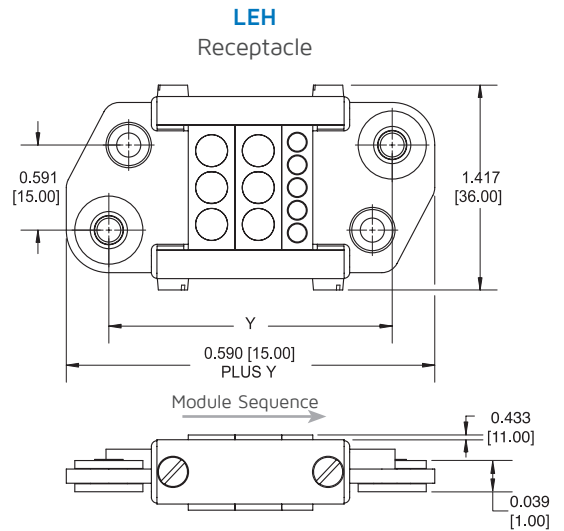

Weight (Excluding Modules)	
H Plug	1.9 oz. at 4 units 2.8 oz. at 20 units
H Receptacle	1.6 oz. at 4 units 2.5 oz. at 20 units

Notes: 1. Available option: 0.125 in. float (use modification 398).
Dimensions are in inches [mm].

Frame J

Latching Metal Backshell

Hooded connector with round cable clamp
Alternate cable clamp locations available

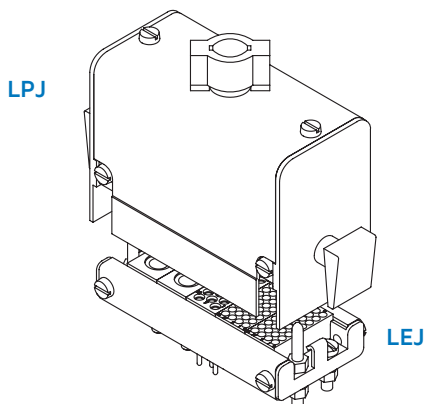

Units	X	Plug*	Receptacle
4	1.122 [28.50]	LPJ4 SCxx	LEJ4
5	1.338 [34.00]	LPJ5 SCxx	LEJ5
6	1.555 [39.50]	LPJ6 SCxx	LEJ6
7	1.771 [45.00]	LPJ7 SCxx	LEJ7
8	1.988 [50.50]	LPJ8 SCxx	LEJ8
9	2.205 [56.00]	LPJ9 SCxx	LEJ9
10	2.421 [61.50]	LPJ10 SCxx	LEJ10
11	2.638 [67.00]	LPJ11 SCxx	LEJ11
12	2.854 [72.50]	LPJ12 SCxx	LEJ12
13	3.070 [78.00]	LPJ13 SCxx	LEJ13
14	3.287 [83.50]	LPJ14 SCxx	LEJ14
15	3.504 [89.00]	LPJ15 SCxx	LEJ15
16	3.720 [94.50]	LPJ16 SCxx	LEJ16
17	3.936 [100.00]	LPJ17 SCxx	LEJ17
18	4.153 [105.50]	LPJ18 SCxx	LEJ18
19	4.370 [111.00]	LPJ19 SCxx	LEJ19
20	4.586 [116.50]	LPJ20 SCxx	LEJ20

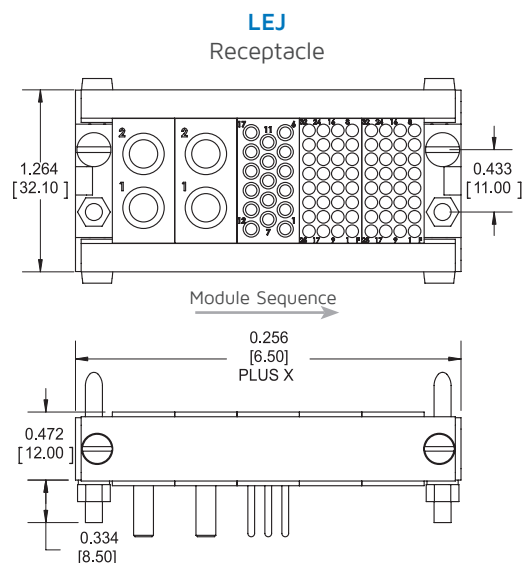
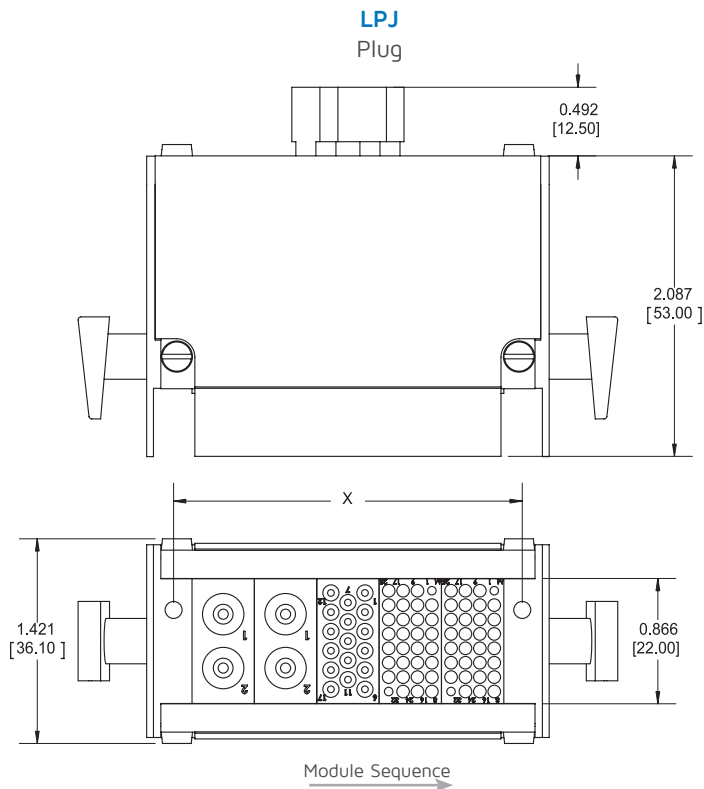

Weight (Excluding Modules)	
Plug	3.5 oz. at 4 units 5.5 oz. at 20 units
Receptacle	1.2 oz. at 4 units 2.1 oz. at 20 units

Notes:
 * SCxx: SC10, SC15, SC20, SC24 (cable clamp size: 10, 15, 20, 24mm)
 There may be some limitations on cable size and/or location in shorter length connectors.
 1. Plugs with flat cable clamp available. Replace J in part number with K and cable clamp callout to SC33 [33mm] or SC50 [50mm]. 2. Plugs without cable clamp available. Replace J in part number with R and remove SC cable clamp callout. Dimensions are in inches [mm].

Frame JV

Jackscrew with Metal Backshell

Hooded connector with round cable clamp
 Side and double openings also available by special order
 Jackscrew extraction

Units	X	Plug*	Receptacle
4	1.122 [28.50]	LPJV4 SCxx	LEJV4
5	1.338 [34.00]	LPJV5 SCxx	LEJV5
6	1.555 [39.50]	LPJV6 SCxx	LEJV6
7	1.771 [45.00]	LPJV7 SCxx	LEJV7
8	1.988 [50.50]	LPJV8 SCxx	LEJV8
9	2.205 [56.00]	LPJV9 SCxx	LEJV9
10	2.421 [61.50]	LPJV10 SCxx	LEJV10
11	2.638 [67.00]	LPJV11 SCxx	LEJV11
12	2.854 [72.50]	LPJV12 SCxx	LEJV12
13	3.070 [78.00]	LPJV13 SCxx	LEJV13
14	3.287 [83.50]	LPJV14 SCxx	LEJV14
15	3.504 [89.00]	LPJV15 SCxx	LEJV15
16	3.720 [94.50]	LPJV16 SCxx	LEJV16
17	3.936 [100.00]	LPJV17 SCxx	LEJV17
18	4.153 [105.50]	LPJV18 SCxx	LEJV18
19	4.370 [111.00]	LPJV19 SCxx	LEJV19
20	4.586 [116.50]	LPJV20 SCxx	LEJV20

Weight (Excluding Modules)	
Plug	1.0 oz. at 4 units 1.9 oz. at 20 units
Receptacle	1.0 oz. at 4 units 1.9 oz. at 20 units

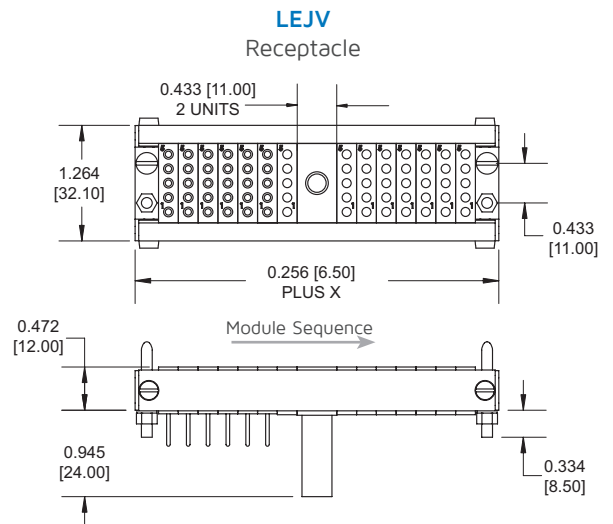
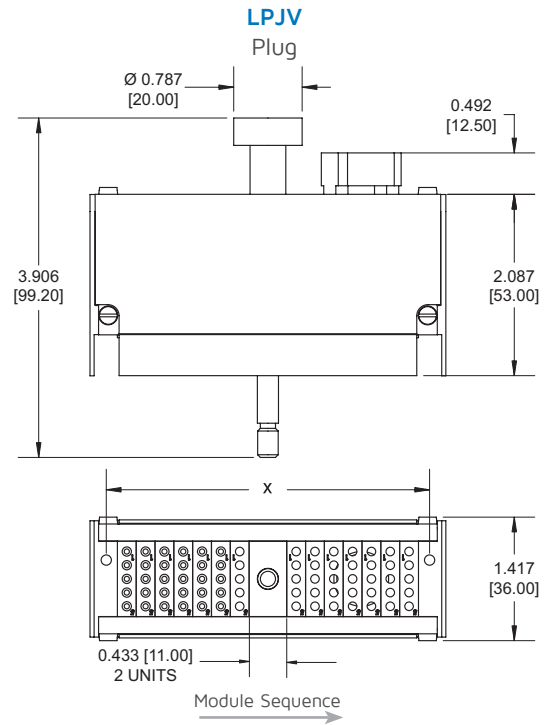

Notes:
 * SCxx: SC10, SC15, SC20, SC24 (cable clamp size: 10, 15, 20, 24mm)
 There may be some limitations on cable size and/or location in shorter length connectors
 1. Plugs with flat cable clamp available. Replace J in part number with K and cable clamp callout to SC33 [33mm] or SC50 [50mm]. 2. Plugs without cable clamp available. Replace J in part number with R and remove SC cable clamp callout.
 Dimensions are in inches [mm].

Frame MV

Jackscrew with Plastic Backshells

- Standard multi-turn jackscrew
- Up to 300 signal contacts (10 W modules in 22 unit frame)
- Adjustable cable clamp: 0.425 to 1.26 [11.50 to 32.00]
- > 5,000 mating cycles
- 36 keying combinations
- Rugged black polycarbonate backshell
- Built-in pin protection
- 12, 15, 20 and 22 unit lengths

Units ⁽¹⁾	A	B	C	Plug	Receptacle
12	2.598 [66.00]	3.11 [79.00]	3.315 [84.20]	LPMV12	LEMV12
15	3.248 [82.50]	3.76 [95.50]	3.965 [100.70]	LPMV15	LEMV15
20	4.331 [110.00]	4.843 [123.00]	5.047 [128.20]	LPMV20	LEMV20
22	4.764 [121.00]	5.276 [134.00]	5.480 [139.20]	LPMV22	LEMV22

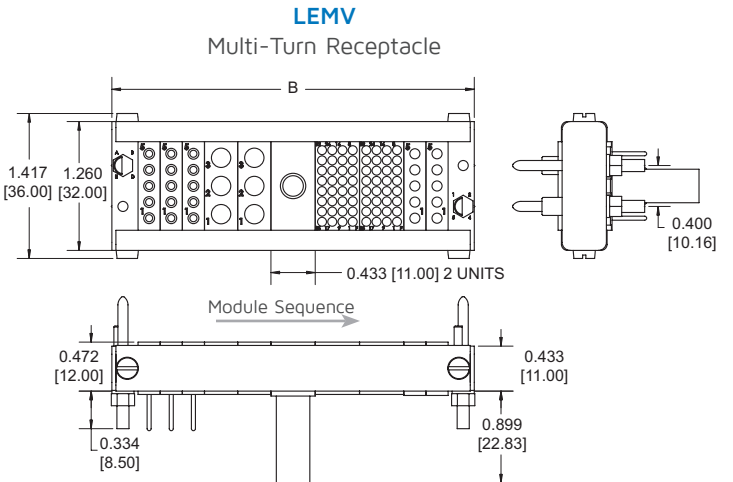
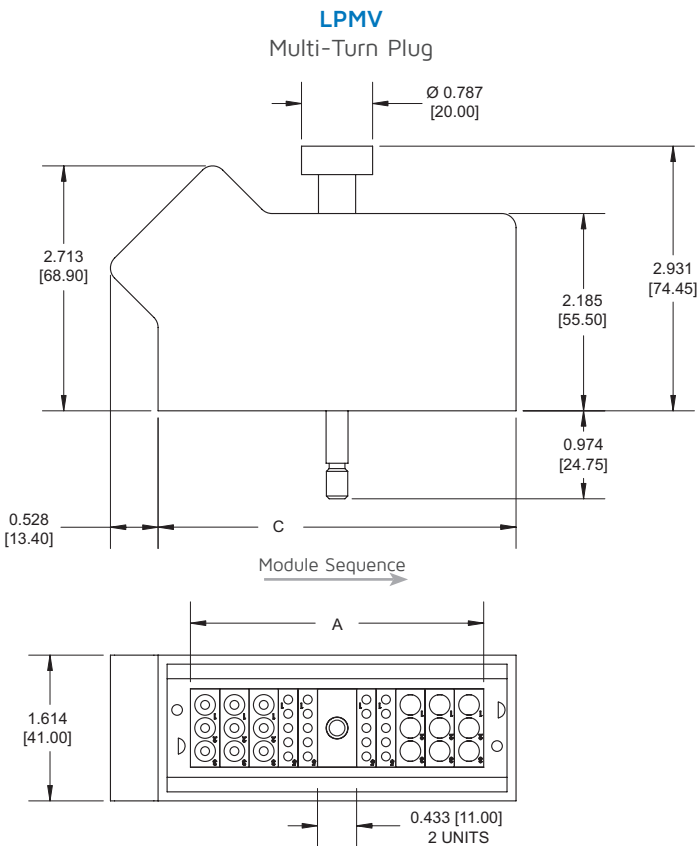

Notes: 1. Allow 2 additional units for frames with Jackscrews
Dimensions are in inches [mm].

Frame MY

Half-Turn Jackscrew with Plastic Backshells

- 180° quick-turn
- Up to 300 signal contacts (10 W modules in 22 unit frame)
- Adjustable cable clamp: 0.425 [11.50] to 1.26 [32.00]
- > 5,000 mating cycles
- 36 keying combinations
- Rugged black polycarbonate backshell
- Built-in pin protection

Units ⁽²⁾	B	C	Plug	Receptacle
12	3.11 [79.00]	3.312 [84.20]	LPMY12	LEMY12
15	3.76 [95.50]	3.965 [100.70]	LPMY15	LEMY15
20	4.843 [123.00]	5.047 [128.20]	LPMY20	LEMY20
22	5.276 [134.00]	5.480 [139.20]	LPMY22	LEMY22

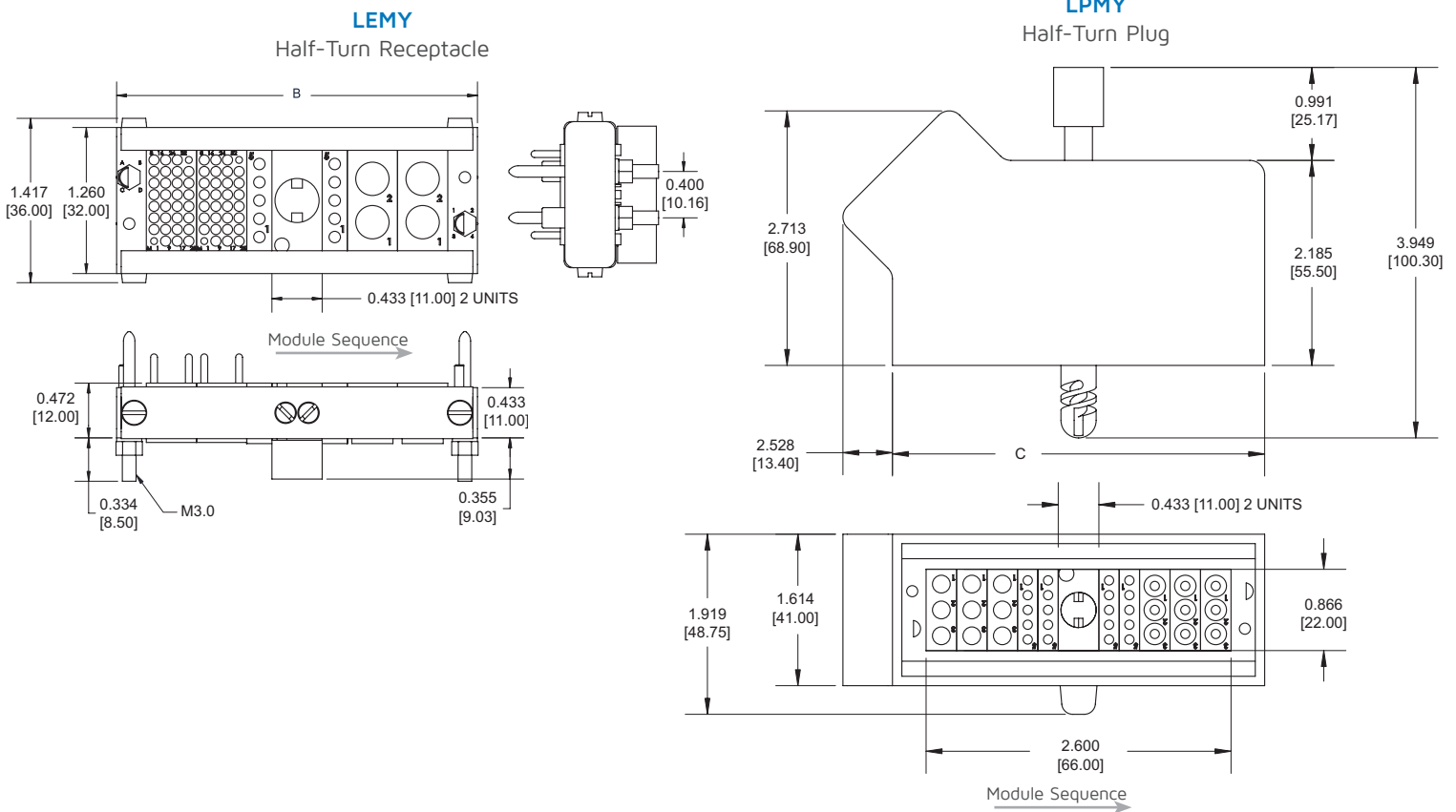

Notes: 1. Half-turn plug frame without hood available as LPMY 2. Allow 2 additional units for frames with Jackscrews
Dimensions are in inches [mm].

Modules

Specifications and Ordering Information

Technical Characteristics

	A	B	C	D	G	K	M	R	S	U	V ⁽¹⁾	W
Current Rating	8 A	15 A	25 A	8 A	200 A	100 A	50 A	8 A	15 A	25/50 A	25 A ⁽²⁾	4 A
Contact Resistance (mΩ)	< 2.5	< 1.0	< 0.8	< 3.0	< 0.2	< 0.35	< 0.4	< 2.5	< 1.5	< 0.8	< 1.5	< 5.0
Extraction Force (oz.) (per contact)	1.0 to 5.0	3.0 to 25.0	4.0 to 32.0	1.0 to 6.5	80.0 to 160.0	15.0 to 90.0	4.0 to 40.0	1.0 to 5.0	3.0 to 28.3	4.0 to 35.0	3.0 to 17.0	0.5 to 2.0
Contact Life Cycle	> 100,000											
Breakdown Voltage (V RMS)	> 2,000	> 1,600	> 3,000	> 1,800	> 1,500	> 1,500	> 3,000	> 1,600	> 2,000	> 2,800	> 1,600	> 2,200
DWV (V RMS)	1,500	1,200	2,250	1,350	1,100	1,100	2,250	1,200	1,500	2,100	1,200	1,650
Insulation Resistance (MΩ at 500 VDC)	10 ⁶	10 ⁶	10 ⁶	10 ⁶	10 ⁶	10 ⁶	10 ⁶	10 ⁴	10 ⁴	10 ⁴	10 ⁴	10 ⁹
Temperature Rating (°C)	-55 to 125	-55 to 125	-55 to 125	-55 to 125	—	—	-55 to 125	-55 to 125	-55 to 125	-55 to 105	-55 to 125	-55 to 125

Approximate Weight

Male Pins (oz.)	0.2	0.35	0.44	0.31	—	—	0.44	0.22	0.23	0.45	0.32	—
Female Sockets (oz.)	0.15	0.25	0.31	0.45	—	—	0.31	0.16	0.35	0.29	0.34	—

Materials

Pin	Brass	Copper	Brass		
Socket	Beryllium copper wires and brass body				
Insulator	Diallyl-phthalate	Polyphthalamide	Diallyl-phthalate	Nylon	Polyphe-lylene sulfide

Contact Plating

Pin (µin gold (min) over nickel)	10/50	30	10/50
Socket	Mating surface: 50 pin gold (min) over nickel Termination: gold flash over nickel		

Notes: 1. Module V Coax version available, see pg. 23 2. 25 A (free air), 17 A (bundled)

Module Accessories

Crimp Tool	Crimp Die Set	Crimp Positioner	Insertion Tool	Extraction Tool	Mounting Bracket
------------	---------------	------------------	----------------	-----------------	------------------

Module R

Style 1			TP1650			
Style 2			TBA			
Style 3	AF8	—	TP592	S0150.01	S0150.01	—
Style 4			TP1128			
Style 5			TP613			

Module S

All Styles	M309	—	TP1179	S0250.01	S0250.01	—
------------	------	---	--------	----------	----------	---

Module U

Style 1	T1264	—	TP1232			
Style 2	T1264	—	TP1232			
Style 3	T1264	—	TP1232	S0350.01	S0350.01	—
Style 4	T712	T761	T758			
Style 5	T1264	—	T1559			

Module W

All Styles	AFM8	—	K547 (Style R only) K547-2 (Style RR only)	T1866	S/DEM1.0060	—
------------	------	---	---	-------	-------------	---

Module F & V Power Contacts

All Styles	M309	—	T1981	—	T1982	—
------------	------	---	-------	---	-------	---

Module F & V Coax Contacts

Center Conductor	AFM8	—	T1957			
Outer Conductor	HX3	T1958 or T2019 for RG316DB	—	—	T1982	—

Module G

All Styles	T1501	—	T1536	—	T1500	T1551
------------	-------	---	-------	---	-------	-------

Module K

All Styles	T1501	—	T1535	—	T1507	T1551
------------	-------	---	-------	---	-------	-------

Module A

8 A Contact Rating

1 unit, 5 Hypertac® hyperboloid fixed contacts, Ø 0.059 [1.50]

Also mates with R crimp modules

 File No.: UL E102195

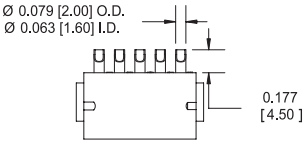
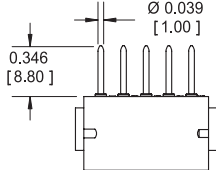
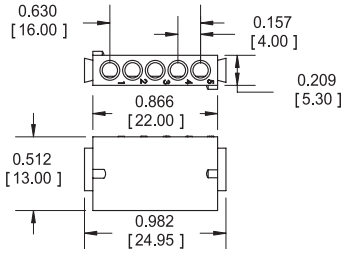
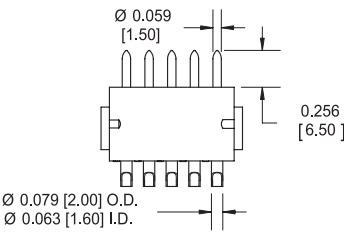
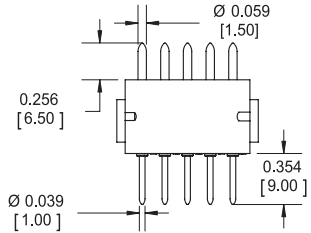
Module	Gender	Termination	Contact Mating	Part Number
 <p>LAF</p>	Female	Solder Cup Up to 16 AWG	50 µin gold	LAFSTAH
 <p>LAF</p>	Female	Straight Dip Solder	50 µin gold	LAFDTAH
 <p>LAHT</p>	Empty Block	—	—	LAHT (ZLM005-001)
 <p>LAM</p>	Male	Solder Cup Up to 16 AWG	10 µin gold	LAMST
				50 µin gold
 <p>LAM</p>	Male	Straight Dip Solder	10 µin gold	LAMDT
				50 µin gold

Module R

8 A Contact Rating

1 unit, 5 Hypertac® hyperboloid "Snap-In" crimp contacts, Ø 0.059 [1.50]

Can be mounted by itself or in a frame

Also mates with A modules

 File No.: UL E102195

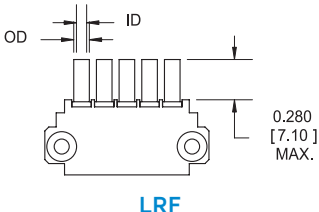
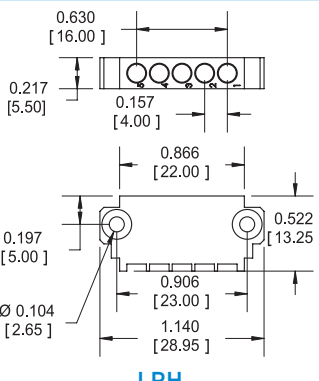
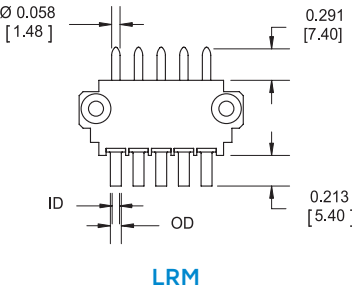
Module	Gender	Wire Gauge	I.D.	O.D.	Contact Mating Surface Plating	Part Number	Replacement Contacts
 <p>LRF</p>	Female	18-22	0.057 [1.45]	0.104 [2.65]	50 µin gold	LRF1	YSK015-013AH
		22-26	0.035 [0.90]	0.051 [1.30]	50 µin gold	LRF2	YSK015-142AH
		16	0.071 [1.80]	0.108 [2.75]	50 µin gold	LRF3	YSK015-014AH
		14	0.079 [2.00]	0.122 [3.10]	50 µin gold	LRF4	YSK015-045AH
		28	0.022 [0.56]	0.076 [1.93]	50 µin gold	LRF5	YSK015-009AH
 <p>LRH</p>	Empty Block	—	—	—	—	LRH (ZLR005-001)	—
 <p>LRM</p>	Male	18-22	0.057 [1.45]	0.104 [2.65]	10 µin gold	LRM1	YPN015-009RG
					50 µin gold	LRM1H	YPN015-009RH
		22-26	0.035 [0.90]	0.051 [1.30]	10 µin gold	LRM2	YPN015-129G
					50 µin gold	LRM2H	YPN015-129H
		16	0.071 [1.80]	0.108 [2.75]	10 µin gold	LRM3	YPN015-010G
					50 µin gold	LRM3H	YPN015-010H
		14	0.079 [2.00]	0.122 [3.10]	10 µin gold	LRM4	YPN015-033RG
					50 µin gold	LRM4H	YPN015-033RH
		28	0.022 [0.56]	0.076 [1.93]	10 µin gold	LRM5	YPN015-004RG
					50 µin gold	LRM5H	YPN015-004RH

Module B

15 A Contact Rating

1.5 units, 3 Hypertac® hyperboloid fixed contacts, Ø 0.098 [2.50]

Also mates with S crimp modules

 File No.: UL E102195

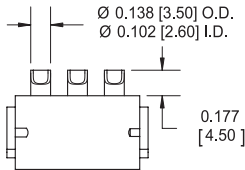
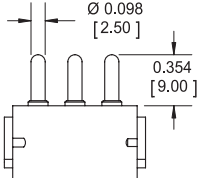
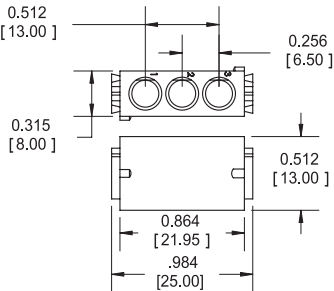
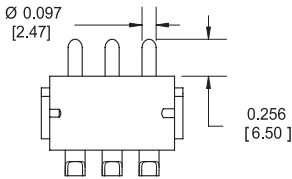
Module	Gender	Termination	Contact Mating Surface Plating	Part Number
 <p>LBF</p>	Female	Solder Cup Up to 12 AWG	50 µin gold	LBFSTAH
 <p>LBF</p>	Female	Straight Dip Solder	50 µin gold	LBFDTAH
 <p>LBHT</p>	Empty Block	—	—	LBHT (ZLM003-001)
 <p>LBM</p>	Male	Solder Cup Up to 12 AWG	10 µin gold	LBMST
			50 µin gold	LBMSTH

Module S

15 A Contact Rating

1.5 units, 3 Hypertac® hyperboloid “Snap-In” crimp contacts, Ø 0.098 [2.50]

Can be mounted by itself or in a frame

Also mates with B modules

 File No.: UL E102195

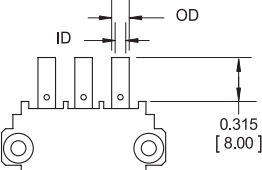
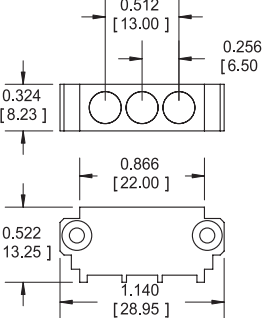
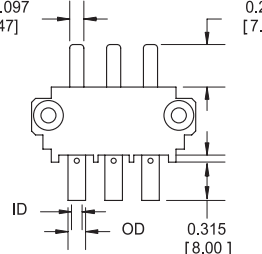
Module	Gender	Wire Gauge	I.D.	O.D.	Contact Mating Surface Plating	Part Number	Replacement Contacts
 <p>LSF</p>	Female	16-22	0.059 [1.50]	0.122 [3.10]	50 µin gold	LSF1	YSK025-003AH
		14-16	0.077 [1.95]	0.122 [3.10]	50 µin gold	LSF2	YSK025-004AH
		12	0.100 [2.54]	0.150 [3.81]	50 µin gold	LSF4	YSK025-013AH
 <p>LSH</p>	Empty Block	—	—	—	—	LSH (ZLS003-002)	—
 <p>LSM</p>	Male	16-22	0.059 [1.50]	0.122 [3.10]	10 µin gold	LSM1	YPN025-002G
		16-22			50 µin gold	LSM1H	YPN025-002H
		14-16	0.077 [1.95]	0.122 [3.10]	10 µin gold	LSM2	YPN025-003G
		14-16			50 µin gold	LSM2H	YPN025-003H
		12	0.100 [2.54]	0.150 [3.81]	10 µin gold	LSM4	YPN025-011RG
		12			50 µin gold	LSM4H	YPN025-011RH

Modules C & M

25 or 50 A Contact Rating

2 units, 2 Hypertac® hyperboloid fixed contacts, Ø 0.138 [3.50]

Also mates with U crimp modules

 File No.: UL E102195

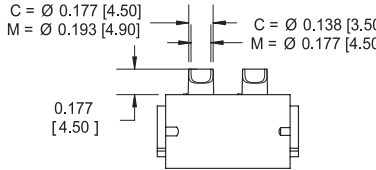
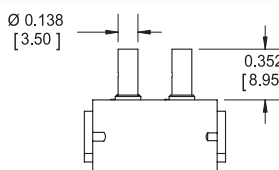
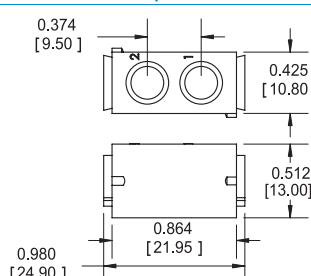
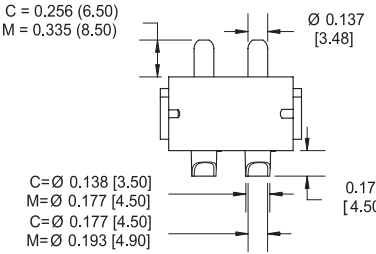
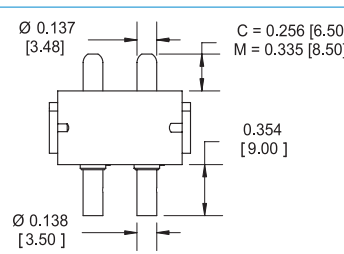
Module	Gender	Termination	Contact Mating Surface Plating	Current Rating	Part Number
 <p>LCF/LMF</p>	Female	Solder Cup Up to 10 AWG	50 µin gold	25 A	LCFSTA H
		Solder Cup Up to 8 AWG		50 A	LMFSTA H
 <p>LCF/LMF</p>	Female	Straight Dip Solder	50 µin gold	25 A	LCFDA TAH
				50 A	LMFDA TAH
 <p>LCHT</p>	Empty Block	—	—	—	LCHT (ZLM002-001)
 <p>LCM/LMM</p>	Male	Solder Cup Up to 10 AWG	10 µin gold	25 A	LCMST
			50 µin gold		LCMSTH
		Solder Cup Up to 8 AWG	10 µin gold	50 A	LMMST
			50 µin gold		LMMSTH
 <p>LCM/LMM</p>	Male	Straight Dip Solder	10 µin gold	25 A	LCMDT
			50 µin gold		LCMDTH
			10 µin gold	50 A	LMMDT
			50 µin gold		LMMDTH

Module U

25 or 50 A Contact Rating

2 units, 2 Hypertac® hyperboloid “Snap-In” crimp contacts, Ø 0.138 [3.50]

Also mates with C & M crimp modules

 File No.: UL E102195

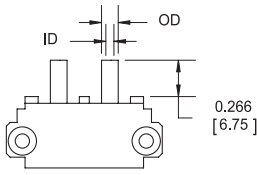
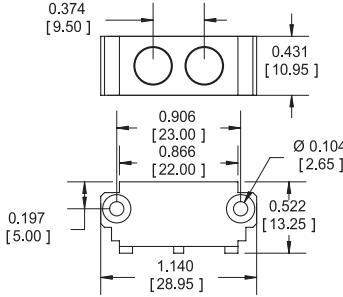
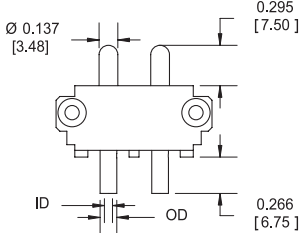
Module	Gender	Wire Gauge	I.D.	O.D.	Contact Mating Surface Plating	Current Rating	Part Number	Replacement Contacts
 <p>LUF</p>	Female	20-22	0.059 [1.50]	0.122 [3.10]	50 µin gold	25 A	LUF1	YSK035-009AH
		16-18	0.077 [1.95]	0.122 [3.10]	50 µin gold	25 A	LUF2	YSK035-010AH
		12-14	0.112 [2.85]	0.161 [4.10]	50 µin gold	25 A	LUF3	YSK035-011AH
		6	0.217 [5.50]	0.285 [7.25]	50 µin gold	50 A	LUF4	YSK035-030AH
		8-10	0.177 [4.50]	0.217 [5.50]	50 µin gold	50 A	LUF5	YSK035-028AH
 <p>LUH</p>	Empty Block	—	—	—	—	—	LUH (ZLU002-001)	—
 <p>LUM</p>	Male	20-22	0.059 [1.50]	0.122 [3.10]	10 µin gold	25 A	LUM1	YPN035-005G
					50 µin gold		LUM1H	YPN035-005H
		16-18	0.059 [1.50]	0.122 [3.10]	10 µin gold	25 A	LUM2	YPN035-006G
					50 µin gold		LUM2H	YPN035-006H
		12-14	0.112 [2.85]	0.161 [4.10]	10 µin gold	25 A	LUM3	YPN035-007G
					50 µin gold		LUM3H	YPN035-007H
		6	0.217 [5.50]	0.285 [7.25]	10 µin gold	50 A	LUM4	YPN035-025RG
					50 µin gold		LUM4H	YPN035-025RH
		8-10	0.177 [4.50]	0.217 [5.50]	10 µin gold	50 A	LUM5	YPN035-023RG
					50 µin gold		LUM5H	YPN035-023RH

Module D

8 A Contact Rating

2 units, 17 Hypertac® hyperboloid fixed contacts, Ø 0.147 [1.20]

 File No.: UL E102195

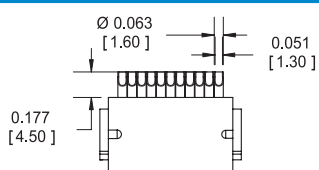
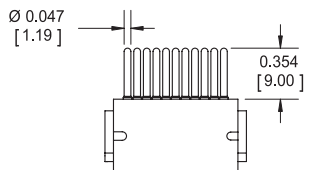
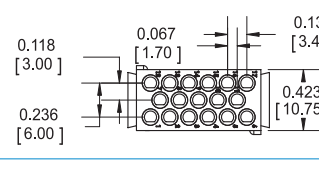
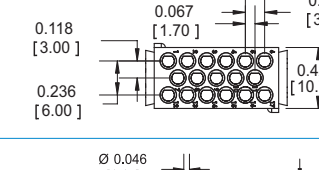
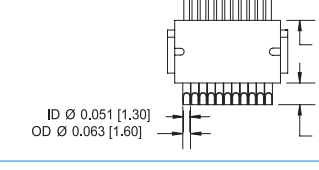
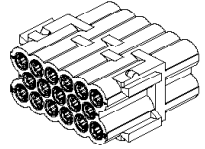
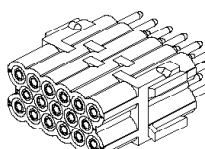
Module	Gender	Termination	Contact Mating Surface Plating	Part Number
 <p>LDF</p>	Female	Solder Cup Up to 20 AWG	50 µin gold	LDFSTAH
 <p>LDF</p>	Female	Straight Dip Solder	50 µin gold	LDFDTAH
 <p>LDM</p>	Empty Male Block	—	—	LDMHT (ZLM017-001)
 <p>LDF</p>	Empty Female Block	—	—	LDFHT (ZLM017-002)
 <p>LDM</p>	Male	Solder Cup Up to 20 AWG	10 µin gold 50 µin gold	LDMST LDMSTH
 <p>LDF</p>	Female	Crimp 20 AWG wire	50 µin gold	LDFRTAH
 <p>LDM</p>	Male	Crimp 20 AWG wire	50 µin gold	LDMRTH

Notes: 1. If assembling the modules into a frame, two YHD0027 clips are required per module.
 2. Crimp tool AF8, Crimp positioner TP1786.

Dimensions are in inches [mm].

Module W

4 A Contact Rating

2 units, 30 Hypertac® hyperboloid removable contacts, Ø 0.024 [0.60]

Can be mounted by itself or in a frame

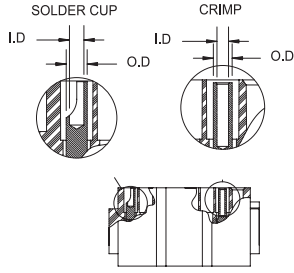
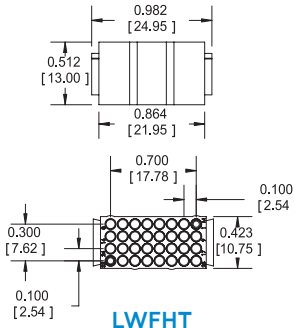
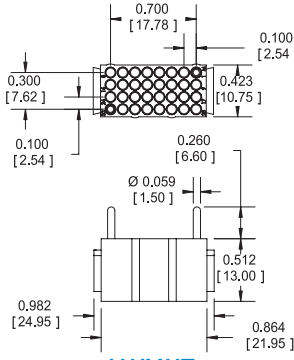
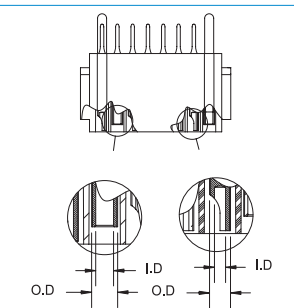
Module	Gender	Termination	I.D.	O.D.	Contact Mating Surface Plating	Part Number	Replacement Contacts
 <p>LWF</p> <p>Guide holes in positions 1 & 32.</p>	Female	Crimp 18-20 AWG	0.055 [1.39]	0.071 [1.80]	50 µin gold	LWFRRTAH	YSK006-089AH
		Crimp 22-26 AWG	0.035 [0.90]	0.051 [1.30]	50 µin gold	LWFRTAH	YSK006-011ANH
		Solder Cup 26 AWG	0.039 [1.00]	0.057 [1.45]	50 µin gold	LWFSTAH	YSK006-010ANH
 <p>LWFHT</p>	Empty Female Block	—	—	—	—	LWFHT (ZLM030-002)	—
 <p>LWMHT</p>	Empty Male Block	—	—	—	—	LWMHT	—
 <p>LWM</p> <p>Guide holes in positions 1 & 32.</p>	Male	Crimp 18-20 AWG	0.055 [1.39]	0.071 [1.80]	10 µin gold	LWMRRT	YPN006-158G
					50 µin gold	LWMRRTH	YPN006-158H
		Crimp 22-26 AWG	0.035 [0.90]	0.051 [1.30]	10 µin gold	LWMRT	YPN006-021G
					50 µin gold	LWMRTH	YPN006-021H
		Solder Cup 26 AWG	0.039 [1.00]	0.057 [1.45]	10 µin gold	LWMST	YPN006-020G
					50 µin gold	LWMSTH	YPN006-020H

Module V

25 A Contact Rating

1.5 units, 3 Hypertac® hyperboloid removable contacts, Ø0.098 [2.50]

Can be mounted by itself or in a frame

 File No.: UL E102195

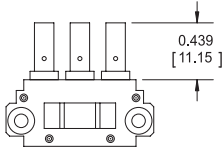
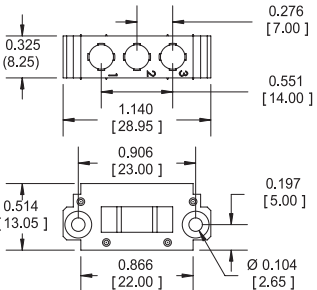
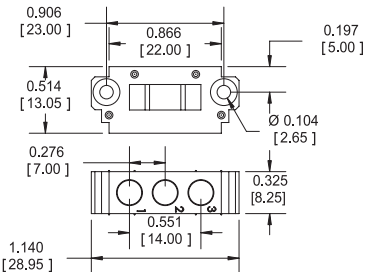
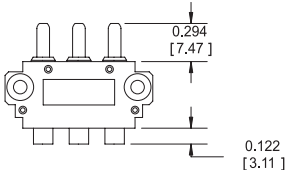
Module	Gender	Termination	Contact Mating	Part Number	Replacement Contacts
 <p>LVF</p>	Female	Crimp 12-14 AWG	50µin gold	LVFP1TAH	YSK025-031AH
 <p>LVFHT</p>	Empty Female Block	—	—	LVFHT (ZLV003-001)	—
 <p>LVMHT</p>	Empty Male Block	—	—	LVMHT (ZLV003-002)	—
 <p>LVMP1TH</p>	Male	Crimp 12-14 AWG	50µin gold	LVMP1TH	YPN025-024H

Notes: 1. Contact shipped unloaded.
Dimensions are in inches [mm].

Module V

Coax

1.5 units, 3 Hypertac® hyperboloid coax contacts (on both signal and ground)
 Can be mounted by itself or in a frame

 File No.: UL E102195

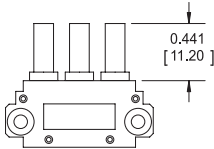
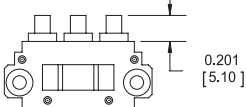
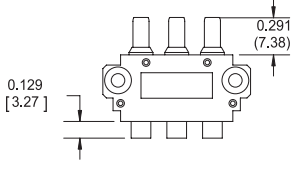
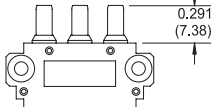
Module	Gender	Termination	Part Number	Replacement Contacts	Cable Termination
 <p>LVF</p>	Female	Crimp Coaxial for RG316	LVFRTAH	YCX0315-002AH	S50302
		Crimp Coaxial for RG316DB	LVFR1TAH	YCX0315-019AH	S50302
 <p>LVF</p>	Female	Solder Coaxial for RG405 or T-Flex 405	LVFSTAH	YCX0315-001AH	S50301 or S50307 (T-Flex)
 <p>LVM</p>	Male	Crimp Coaxial for RG316	LVMRTH	YCX0315-004H	S50304
		Crimp Coaxial for RG316DB	LVMR1TH	YCX0315-018H	S50304
 <p>LVM</p>	Male	Solder Coaxial for RG405 or T-Flex 405	LVMSTH	YCX0315-003H	S50303 or S50308 (T-Flex)

*Please request specs from our customer service department.

COAXTAC™

Nominal Impedance	50 Ω
Frequency Range	DC 3 GHz with RG316 DC 18 GHz with RG405
Contact Resistance	Inner Contact Outer Contact
	8 mΩ max. 2 mΩ max.
Temperature Rating	-55° to 125° C
Voltage Standing Wave Ratio	(DC to 3 GHz) 1:20:1 max. (3 GHz to 18 GHz) 1:50:1 max. 0.50 dB at 18 GHz
RF Transmission Loss	
Insulation Resistance	5,000 MΩ min.
DWV	500 V RMS
Extraction Force Per Contact	1.5 to 6.0 oz. max. 3.0 oz. average
Connector Life Cycle	> 25,000 cycles

MATERIALS & FINISHES

Materials	Brass, beryllium copper PTFE fluorocarbon
Finishes	
Center Contacts & Housings	Gold over nickel over copper
Wire	Gold over nickel

Dimensions are in inches [mm].

Module G

200 A Contact Rating

3.5 units, 1 Hypertac® hyperboloid removable crimp contact, Ø 0.239 [6.08]
 Recommended for LEH and LPH frames only

 File No.: UL E102195

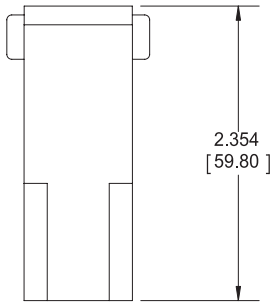
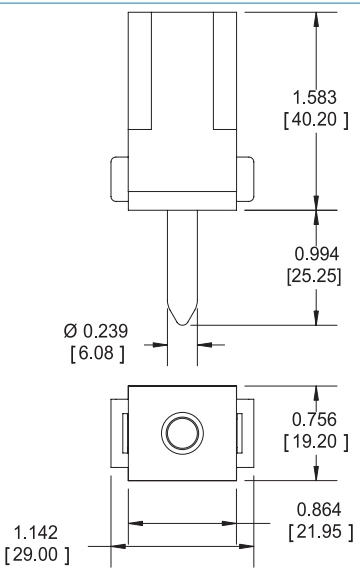
Module	Gender	Termination	I.D.	Contact Mating Surface Plating	Part Number	Replacement Contacts
 <p>LGF</p>	Female	Crimp 1/0 AWG	0.445 [11.30]	50 µin gold	LGFRTAH	YSK0612-015AH
 <p>LGM</p>	Male	Crimp 1/0 AWG	0.445 [11.30]	30 µin gold	LGMRTI	YPN0612-021RI

Notes: 1. Contacts shipped unloaded. 2. Approved for 180 Amps by CSA for 30° C temperature rise. Dimensions are in inches [mm].

Module K

100 A Contact Rating

2.5 units, 1 Hypertac® hyperboloid removable crimp contact, Ø 0.169 [4.30]
 Recommended for LEH and LPH frames only

 File No.: UL E102195

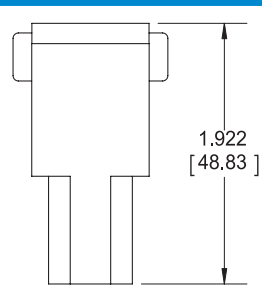
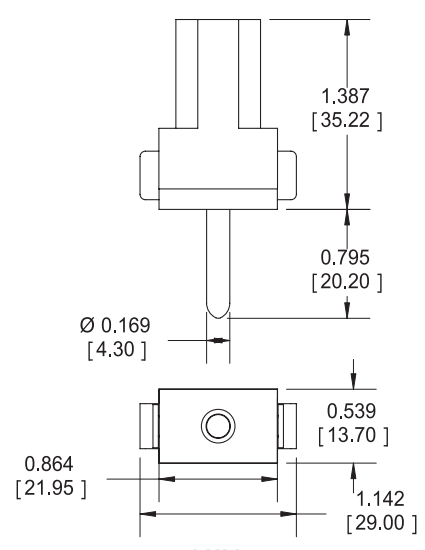
Module	Gender	Termination	I.D.	Contact Mating Surface Plating	Part Number	Replacement Contacts
 <p>LKF</p>	Female	Crimp 4 AWG	0.283 [7.20]	50 µin gold	LKFRTAH	YSK043-010AH
 <p>LKM</p>	Male	Crimp 4 AWG	0.283 [7.20]	30 µin gold	LKMRTI	YPN043-016RI

Notes: 1. Contacts shipped unloaded. Dimensions are in inches [mm].

Module F

Fiber Optic & Coax or Power Module

1.5 units, 2 butt joint fiber optic contacts & 1 Coaxtac or 1 power (25A) contact

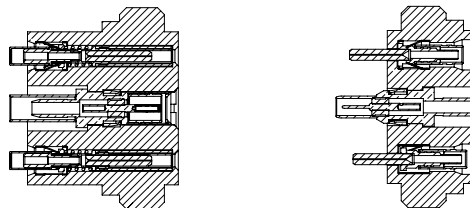

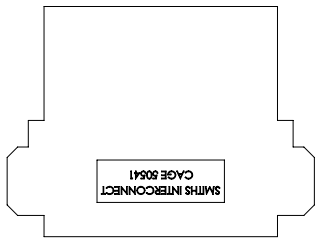
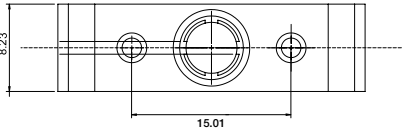
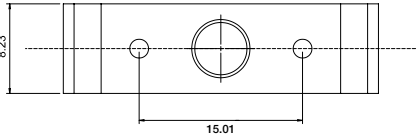
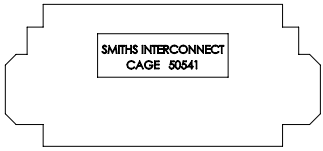
Module	Gender	Module Part Number	Contact part numbers (sold separately)
  <p>LFF</p>	Female Empty Block	LFHHT	<p>FOR FEMALE MODULE:</p> <p>Fiber Optic: Socket terminus 1.3mm 62.5/125um multimode FO cable</p> <ul style="list-style-type: none"> Contact p/n: 853-0011788-001 protective cap: 218-0000508 <p>Coaxtac coaxial contacts:</p> <ul style="list-style-type: none"> p/n for RG316 (crimp): - YCX0315-002AH p/n for RG316DB (crimp): - YCX0315-019AH p/n for RG405 or T-Flex 405 (solder): - YCX0315-001AH <p>Hypertac® Power Contacts (25A):</p> <ul style="list-style-type: none"> p/n for 12-14 AWG crimp socket: - YSK025-031AH
  <p>LFM</p>	Male Empty Block	LFMHT	<p>FOR MALE MODULE:</p> <p>Fiber Optic: Pin terminus for 1.3mm 62.5/125um multimode FO cable</p> <ul style="list-style-type: none"> Contact p/n: 238533-0000 (dust cap included) <p>Coaxtac coaxial contacts</p> <ul style="list-style-type: none"> p/n for RG316 (crimp): - YCX0315-004H p/n for RG316DB (crimp): - YCX0315-018H p/n for RG405 or T-Flex 405 (solder): - YCX0315-003H <p>Hypertac® Power Contacts (25A)</p> <ul style="list-style-type: none"> p/n for 12-14 AWG crimp pin: - YPN025-024H

Notes:

- Contacts are not included with the insulators, must be purchased separately and installed in the insulator modules after termination.
- Insulator material: polyetherimide, black
- Coax tools:
 - Center conductor: AFM8 crimper & T1957 positioner
 - Outer conductor: HX3 crimper & T1958 (T2019 for RG316DB) die set
 - Extraction tool: T1982

Dimensions are in mm

Module PN

Pneumatic*

2 units, 2 pneumatic contacts

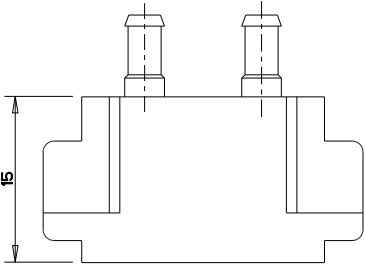
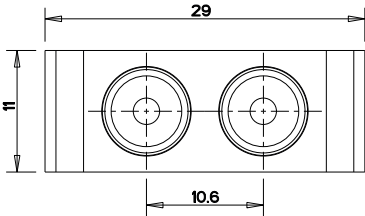
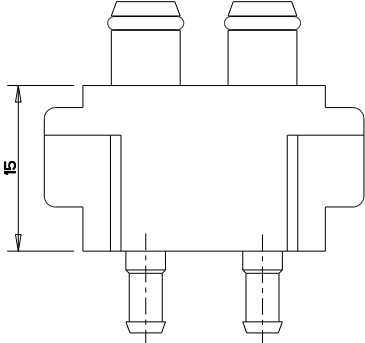
Module	Gender	Part Number	Tubing ID	Contacts
	Female	LPNF	4 mm	M0918 Nominal ID 2.5 mm
	Empty	LPNH	—	—
	Male	LPNM	4 mm	M0919 Nominal ID 2.5 mm

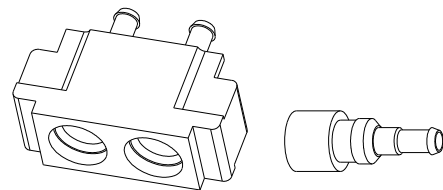
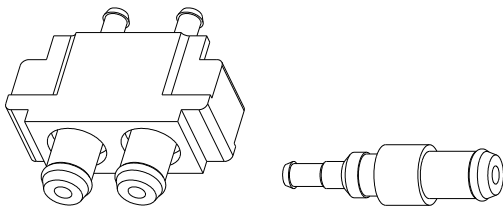

* Operating medium: Compressed air in accordance with ISO8573-1:2010 [7:-:-]
 Note on operating and pilot medium: Lubricated operation possible
 Dimensions are in mm

Mounting Dimensions

UNITS	X	Y
4	1.122 [28.50]	1.969 [50.00]
5	1.338 [34.00]	2.185 [55.50]
6	1.555 [39.50]	2.402 [61.00]
7	1.771 [45.00]	2.618 [66.50]
8	1.988 [50.50]	2.835 [72.00]
9	2.205 [56.00]	3.051 [77.50]
10	2.421 [61.50]	3.268 [83.00]
11	2.638 [67.00]	3.484 [88.50]
12	2.854 [72.50]	3.701 [94.00]
13	3.070 [78.00]	3.917 [99.50]
14	3.287 [83.50]	4.134 [105.00]
15	3.504 [89.00]	4.350 [110.50]
16	3.720 [94.50]	4.567 [116.00]
17	3.936 [100.00]	4.784 [121.50]
18	4.153 [105.50]	5.00 [127.00]
19	4.370 [111.00]	5.217 [132.50]
20	4.586 [116.50]	5.433 [138.00]
21	4.803 [122.00]	5.650 [143.50]
22	5.019 [127.50]	5.866 [149.00]

Stationary Mounting

For Frame Types: A, B, BV, J, JV, K, KV, R, RV

Mount to Wiring Side of Connector

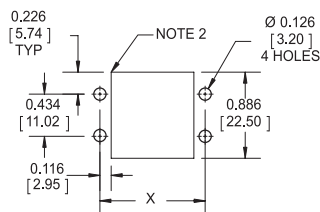

Stationary with Jackscrew Extraction

Three alternate mounting dimensions for receptacle to provide clearance for jackscrew base hold down clamps

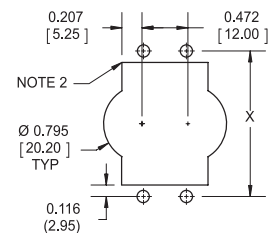
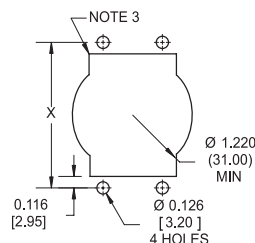
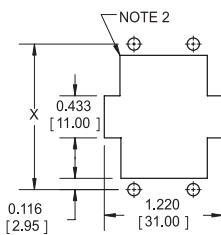

Notes: 1. Standard frames are shipped completely assembled with the selected modules mounted. 2. 59.0 oz. in torque for mounting. 3. 0.010 [0.25] maximum radius typical. Dimensions are in inches [mm].

Float Mounting

For Frame Type H

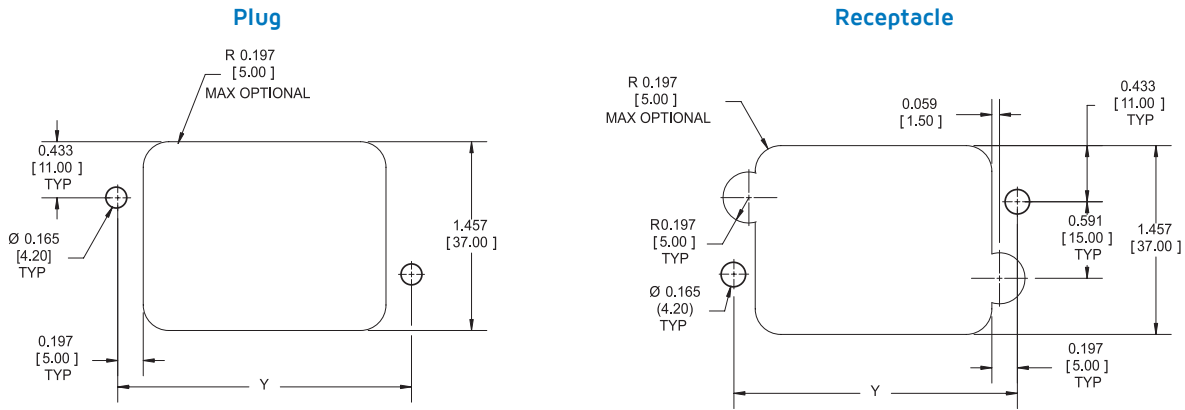

Mounting

For Frame Type MV & MY

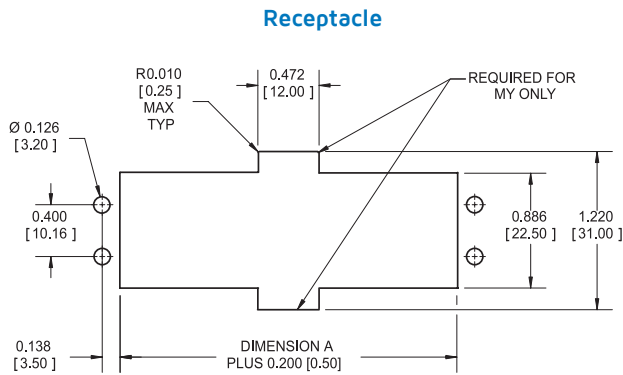

UNITS	A
12	2.598 [66.00]
15	3.248 [82.50]
20	4.331 [110.00]
22	4.764 [121.00]

Notes: 1. Standard frames are shipped completely assembled with the selected modules mounted. 2. 59.0 oz. in torque for mounting. 3. 0.010 [0.25] maximum radius typical. Dimensions are in inches [mm].

Worldwide Support

Connectors

Americas

Sales

connectors.uscsr@smithsinterconnect.com

Technical Support

connectors.ustechsupport@smithsinterconnect.com

Europe

Sales

connectors.emeacsr@smithsinterconnect.com

Technical Support

connectors.emeatechsupport@smithsinterconnect.com

Asia

Sales

asiacsr@smithsinterconnect.com

Technical Support

asiatechsupport@smithsinterconnect.com

Fibre Optics & RF Components

Americas

Sales

focom.uscsr@smithsinterconnect.com

Technical Support

focom.techsupport@smithsinterconnect.com

Europe

Sales

focom.emeacsr@smithsinterconnect.com

Technical Support

focom.techsupport@smithsinterconnect.com

Asia

Sales

focom.asiacsr@smithsinterconnect.com

Technical Support

focom.techsupport@smithsinterconnect.com

Semiconductor Test

Americas

Sales

semi.uscsr@smithsinterconnect.com

Technical Support

semi.techsupport@smithsinterconnect.com

Europe

Sales

semi.emeacsr@smithsinterconnect.com

Technical Support

semi.techsupport@smithsinterconnect.com

Asia

Sales

semi.asiacsr@smithsinterconnect.com

Technical Support

semi.techsupport@smithsinterconnect.com

RF/MW Subsystems

Americas, Europe & Asia

Sales

subsystems.csr@smithsinterconnect.com

Technical Support

subsystems.techsupport@smithsinterconnect.com

Connecting Global Markets

more > [smithsinterconnect.com](https://www.smithsinterconnect.com) | [in](#) [twitter](#) [youtube](#)

Copyright© 2022 Smiths Interconnect | All rights reserved | Version 1.0

The information contained within this document is subject at all times to applicable Export Control regulations and legal requirements