

# Battery Contacts and Dovetail Connectors

Highly configurable spring probes connectors



## Spring probe technology

Smiths Interconnect is a world leader in spring contact probe design and an industry's expert in applying spring probes as connector contacts. Embodied in our connector products, probes are an enabling technology that fundamentally changes the capabilities of the products in which they are incorporated. Spring contact probes provide repeatable contact in the field for modular components, reduce costs, and eliminate cable connections by providing a dependable direct connection in rotating or sliding joints.

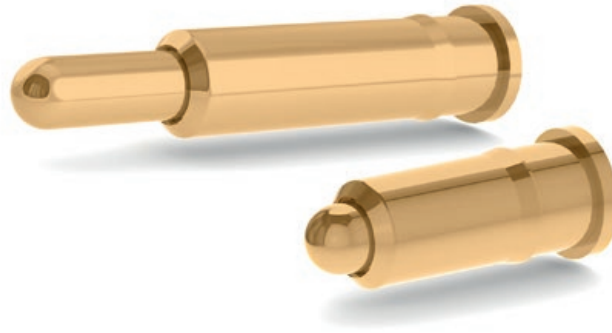

## Features and benefits

### Low profile, high compliance ratio

Spring probe technology permits a very high compliance-to-length ratio. This allows Smiths Interconnect to design connectors as dense as 2 mm, while maintaining 0.5 mm of compliance. Spring probe connectors are low profile designs which are forgiving of challenging mating conditions and vibration environments.

### High frequency

A short signal path, combined with design and signal integrity expertise, ensures remarkable connector solutions for both analogue and digital applications.

### Low stable resistance

Smiths Interconnect's spring probes feature several innovations for control of DC performance. Advanced biasing techniques provide excellent stability of contact resistance, even under conditions of heavy shock and vibration. Our connectors can be designed to withstand up to 30 A of current.

### Higher current ratings

The design parameters of the contact (e.g., the number, diameter and angle of the wires) may be modified for any requirement.

The number of wires can be increased so the contact area is distributed over a larger surface. Thus, the high current carried by each wire because of its intimate line contact, can be multiplied many times.

### High insertion life

Spring contact probes are capable of remarkable longevity from 20k to 300k cycles based on design. Our probes are driven by helical coil springs, which maintain a constant force of contact over millions of cycles. Our extensive plating and materials knowledge combined with engineering expertise delivers contacts that exceed the highest customer specifications for insertion life.

### Excellent for blind mate

Spring probe connectors are compliant on the surface of their mating half, rather than extending into it as with conventional pin and socket connectors, allowing unique blind-mate capabilities. Designed to engage and disengage at a 90° angle to its target, wiping into positions to clear contaminants, making probe technology the best approach to quick-disconnect applications.

### Exceptional misalignment tolerance

A spring contact probe only requires a flat pad for its target. It will safely mate to that target if its tip strikes with the target's diameter. A probe-based connector is thus very forgiving of X-Y-Z, angular and rotational misalignment.

### Environmentally sealed

Smiths Interconnect's application expertise and the durable nature of our contacts permit us to design connectors with excellent performance in harsh environments. IP68 and MIL810 requirements can be accommodated without sacrificing performance.

### Shock and vibration

Spring contact probes provide a constant force against the mating contact surface, easily absorbing and compensating for movement seen during shock and vibration without contact interruption as defined by MIL-STD-810F.

# C series probes

## Compliant electric battery contacts

Smiths Interconnect's advanced C series probes offer exceptional compliance and design flexibility in a wide range of applications. To enhance the capability of the series in military applications, a version was developed which uses a bias ball design to guarantee electrical performance especially in terms of vibration and shock.

## Technical characteristics

Minimum centers	0.100 (2.54)
-----------------	--------------

### Electrical

<b>Current rating</b>	
Ground	10 A continuous
Power	10 A continuous
Bias ball*	15 A continuous (individual probe in free air @ ambient temperature)
<b>Typical resistance</b>	
Ground	<10 mΩ
Power	<10 mΩ
Bias ball*	<10 mΩ

### Mechanical

<b>Spring force</b>	
4 mm	85 g @ working travel
6 mm	82 g @ working travel
Bias ball*	130 g @ working travel
<b>Working travel</b>	
4 mm ground	0.039 (1.00)
4 mm power	0.028 (0.71)
6 mm ground	0.098 (2.50)
6 mm power	0.079 (2.00)
<b>Maximum travel</b>	
4 mm ground	0.039 (1.00)
4 mm power	0.028 (0.71)
6 mm ground	0.098 (2.50)
6 mm power	0.079 (2.00)

### Materials

Barrel	Brass, gold plated
Spring	Stainless steel
Plunger	Brass, gold plated

### Recommendations

Mounting hole	0.064/0.065 (1.62/1.65)
Surface mount pad size	0.085 (2.20)
Solder cup wire gage	20 gage max.
Thru hole drill size	0.035 (0.89)

\*Bias ball version available in 6 mm only.  
Note: Dimensions are in inches (mm)

# Spring probes dimensions

Surface mount

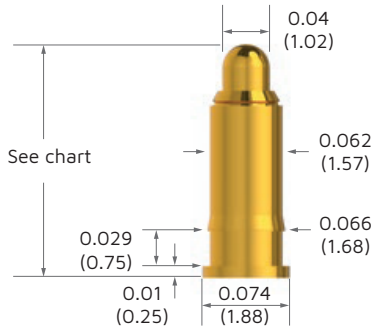

Thru hole

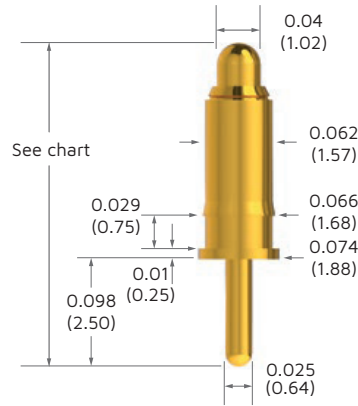

Solder cup

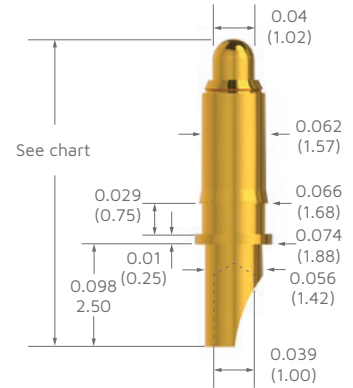

## Overall lengths

Probe	Current	Surface mount	Thru hole	Solder cup
4 mm	Ground	0.197 (5.00)	0.295 (7.50)	0.295 (7.50)
6 mm	Ground	0.335 (8.50)	0.433 (11.00)	0.433 (11.00)
6 mm Bias ball	Ground	0.314 (7.98)	0.412 (10.48)	0.412 (10.48)
4 mm	Power	0.185 (4.70)	0.283 (7.20)	0.283 (7.20)
6 mm	Power	0.315 (8.00)	0.413 (10.50)	0.413 (10.50)
6 mm Bias ball	Power	0.296 (7.52)	0.394 (10.02)	0.394 (10.02)

Note: Dimensions are in inches (mm)



# Performance

## Shock and vibration testing

Thorough shock and vibration testing revealed that the C series probes passed vibrations tests >15 g and shock tests >50 g regardless of the internal biasing technology. During the resonance frequencies testing, the 15 g input resulted in levels up to 120 g (radial direction) and 60 g (axial direction) at the interface between PCB and spring probe plunger.

After more than 10 hours of vibration and shock testing, the contact surfaces of the spring probe tip and PCB are still free of any wearing or fretting corrosion with near perfect surface finish.

### Vibration X axis

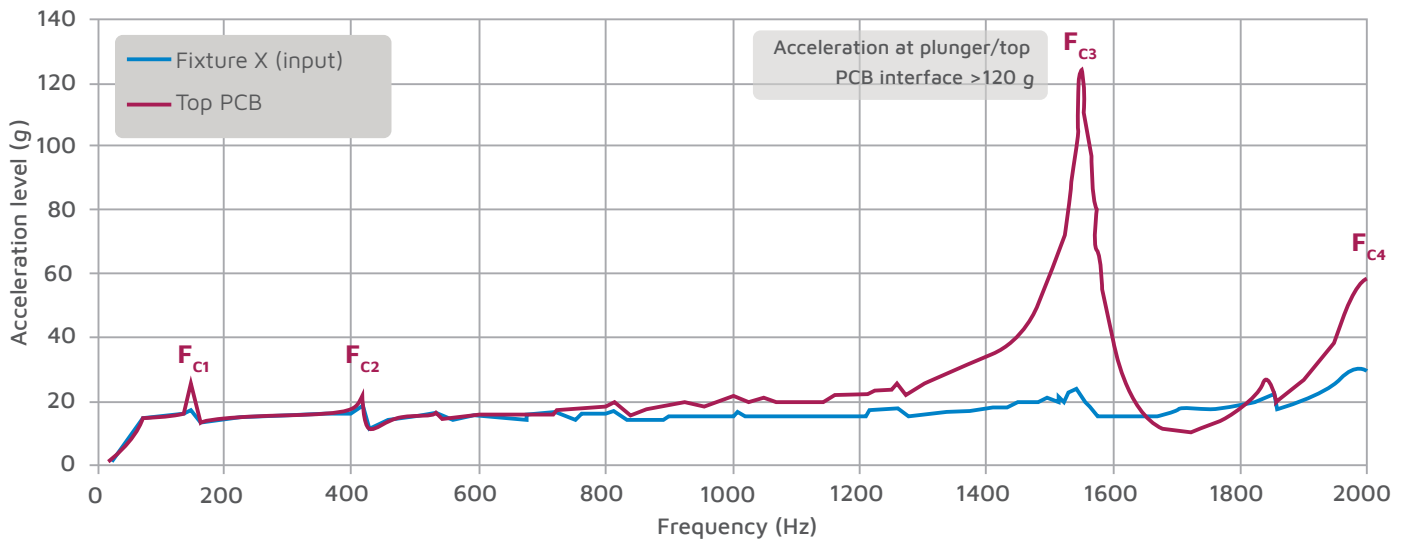

### Vibration Y axis

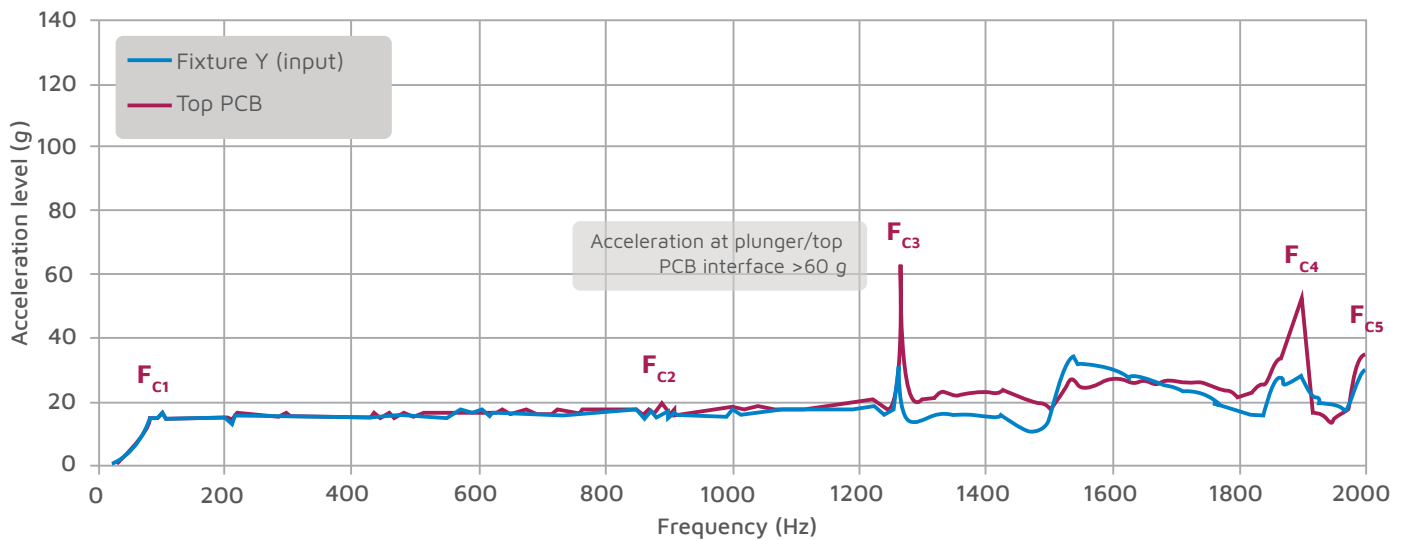

## How to order



1 2



3







4



5

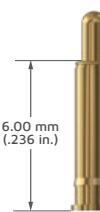

6

1 C probe series	Series [fixed]]		
2 Type	<b>G</b> Ground	<b>P</b> Power	
3 2.5 mm (.100 in.) pitch	Series [fixed]		
4 Compressed height	<b>4</b> 4 mm  4.00 mm (.157 in.)	<b>6</b> 6 mm  6.00 mm (.236 in.)	
5 Termination	<b>S M</b> Surface mount 	<b>T H</b> Thru hole 	<b>S C</b> Solder cup* 
6 Biasing technique <i>Omit for standard versions</i>	<b>B B</b> Bias ball (6 mm option only) 		

\* 20 gage maximum wire diameter

# Dovetail connector series

Configurable spring probe interconnect solution



Smiths Interconnect's Dovetail connector series features C series probes, renowned for their excellent shock and vibration performance, housed in a patented block design.

The symmetrical blocks interlock to allow for simple configuration into any imaginable X-Y pattern. A multitude of probe options permit the benefits of a custom connector design such as intermixing of power and ground functions within the same array.

The Dovetail connector allows users to explore the benefits of spring probe technology without the up front costs involved with tooling a custom connector.

## Features and benefits

### Immediate delivery

Ideal for high mix, low to medium volume manufacturing scales

### Custom configurations

Available individually or pre-configured to meet application specific requirements

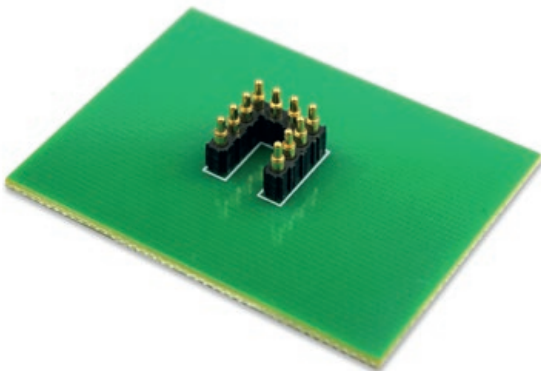

### Dovetail design

Interlocking features permit population to a wide range of footprints.



### Probe diversity

A variety of termination styles, signal path lengths, and performance functions are accommodated within a uniform block design.

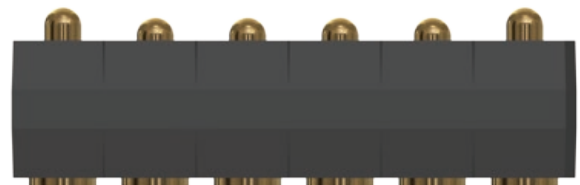

# Probe options

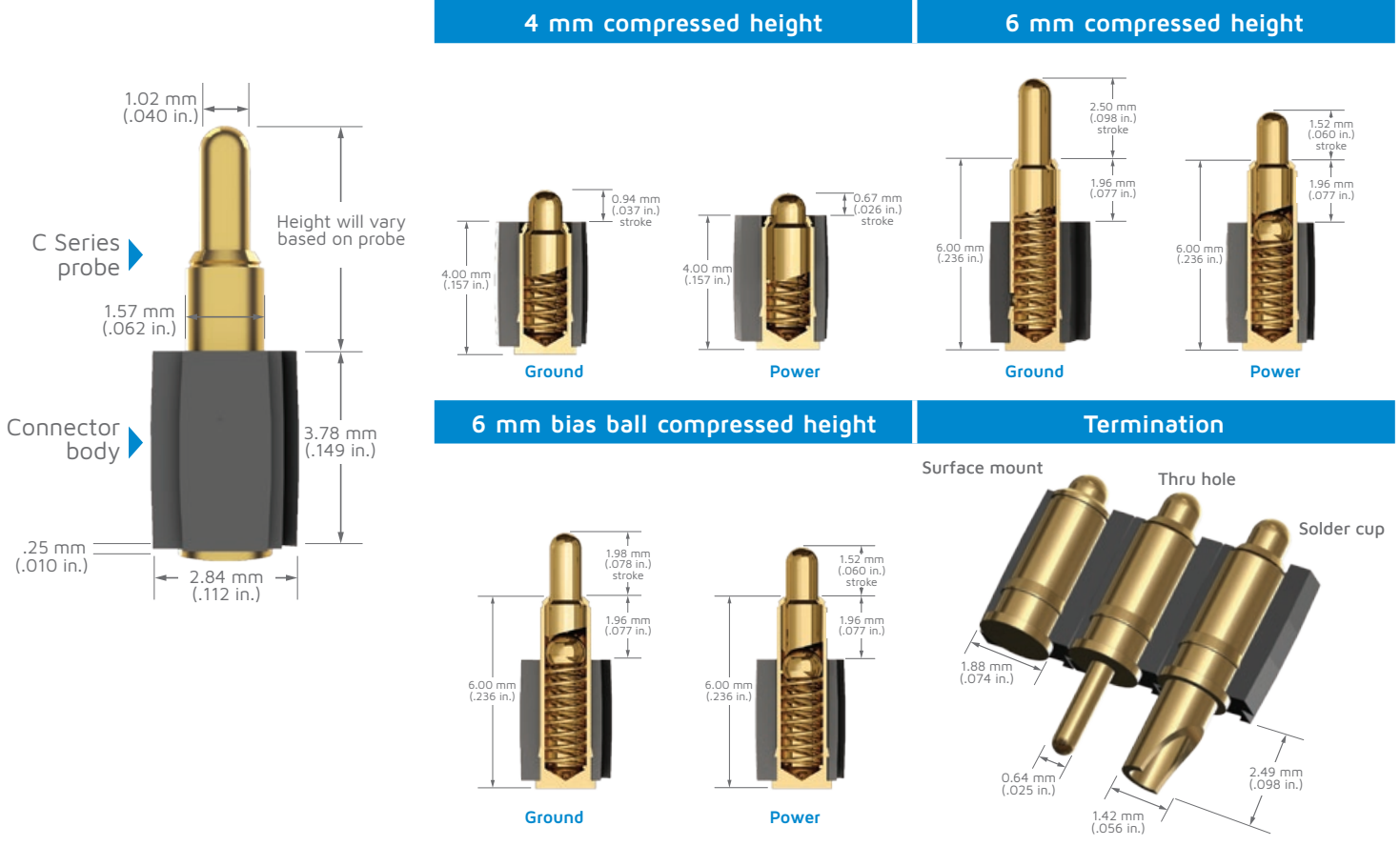

# Probe specifications

	Compressed height		
	4 mm	6 mm	6 mm bias ball
Pitch	2.54 mm (.100 in.)		
Typical resistance	<10 mΩ		
Current rating* continuous	10 A		15 A continuous
Spring force @ working travel	85 g (3.0 oz.)	82 g (2.9 oz.)	130 g (4.6 oz.)

\*Current ratings typical of single probe in ambient environment

# Durability

- Consistent performance across broad temperature ranges
- Perfect for RF, high speed, and mixed signal connections
- Minimal insertion and return loss for signals up to 10 GHz
- Superior continuity in high shock and vibration environments
- Consistent, low resistance through tens of thousands of connections

# How to order

D

1

C

2 3





2.5

4

5

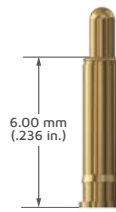
6

7

1 Dovetail connector series	Series [fixed]		
2 C probe series	Series [fixed]		
3 Type	<p><b>G</b> Ground</p>	<p><b>P</b> Power</p>	
4 2.5 mm (.100 in.) pitch	Series [fixed]		
5 Compressed height	<p><b>4</b> 4 mm</p> 	<p><b>6</b> 6 mm</p> 	
6 Termination	<p><b>S M</b> Surface mount</p> 	<p><b>T H</b> Thru hole</p> 	<p><b>S C</b> Solder cup*</p> 
7 Biasing technique <i>Omit for standard versions</i>	<p><b>B B</b> Bias ball <i>(6 mm option only)</i></p> 		

\* 20 gage maximum wire diameter

# Worldwide Support

## Connectors Americas

### Sales

connectors.uscsr@smithsinterconnect.com

### Technical Support

connectors.ustechsupport@smithsinterconnect.com

## Europe

### Sales

connectors.emeacsr@smithsinterconnect.com

### Technical Support

connectors.emeatechsupport@smithsinterconnect.com

## Asia

### Sales

asiacsr@smithsinterconnect.com

### Technical Support

asiatechsupport@smithsinterconnect.com

## Fiber Optics & RF Components Americas

### Sales

focom.uscsr@smithsinterconnect.com

### Technical Support

focom.techsupport@smithsinterconnect.com

## Europe

### Sales

focom.emeacsr@smithsinterconnect.com

### Technical Support

focom.techsupport@smithsinterconnect.com

## Asia

### Sales

focom.asiacsr@smithsinterconnect.com

### Technical Support

focom.techsupport@smithsinterconnect.com

## Semiconductor Test Americas

### Sales

semi.uscsr@smithsinterconnect.com

### Technical Support

semi.techsupport@smithsinterconnect.com

## Europe

### Sales

semi.emeacsr@smithsinterconnect.com

### Technical Support

semi.techsupport@smithsinterconnect.com

## Asia

### Sales

semi.asiacsr@smithsinterconnect.com

### Technical Support

semi.techsupport@smithsinterconnect.com

## RF/MW Subsystems Americas, Europe & Asia

### Sales

subsystems.csr@smithsinterconnect.com

### Technical Support

subsystems.techsupport@smithsinterconnect.com

# Connecting Global Markets

more > [smithsinterconnect.com](https://www.smithsinterconnect.com) | [in](#) [twitter](#) [youtube](#)

Copyright© 2023 Smiths Interconnect | All rights reserved | Version 1.0

The information contained within this document is subject at all times to applicable Export Control regulations and legal requirements.