

# KA Series

MIL-DTL-55302 Compliant PCB connectors

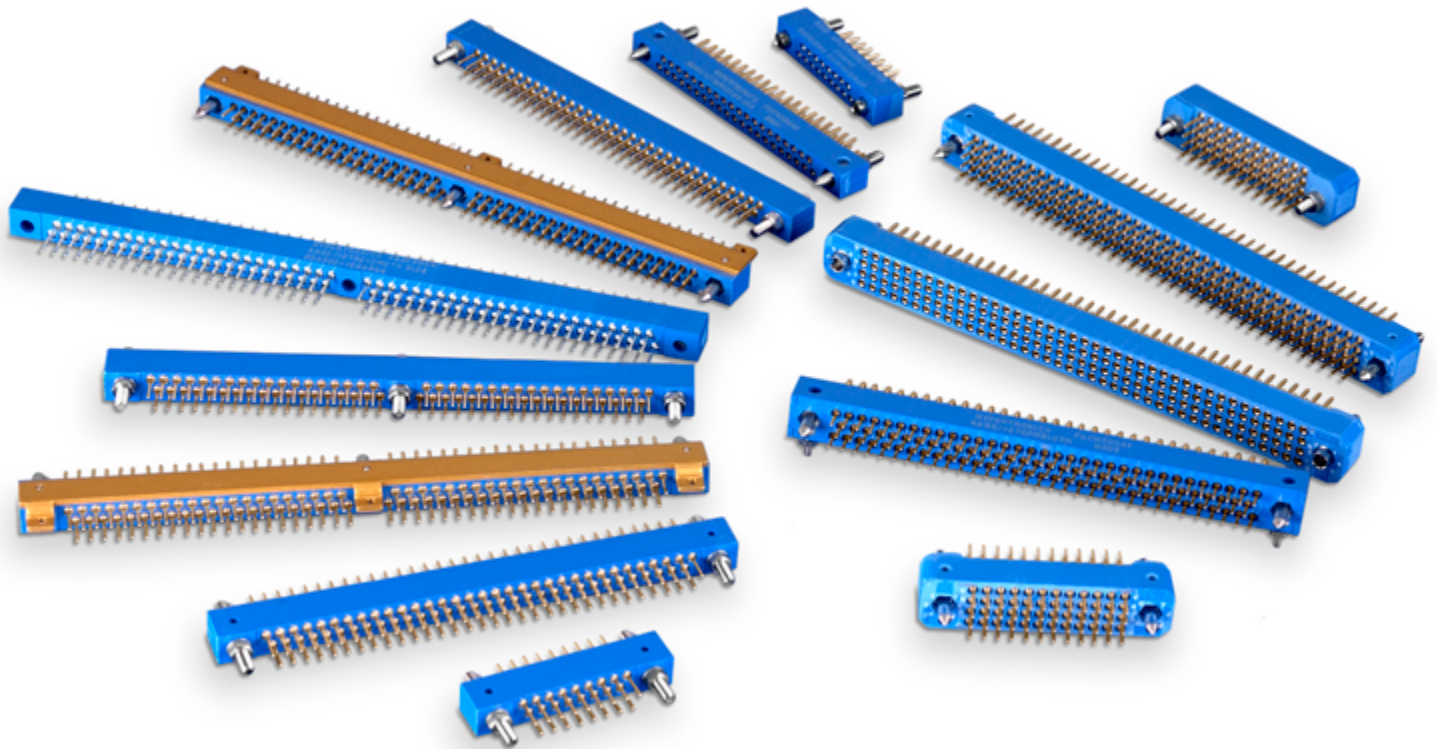

# Hypertac® Hyperboloid Technology

Smiths Interconnect offers an extensive range of superior contact technologies suitable for standard and custom solutions. Hypertac® (HYPERboloid conTAct) is the original superior performing hyperboloid contact technology designed for use in all applications and in harsh and demanding environments where high reliability and safety are critical. The inherent electrical and mechanical characteristics of the Hypertac hyperboloid contact ensures unrivalled performance in terms of reliability, number of mating cycles, low contact force and minimal contact resistance.

The shape of the contact sleeve is formed by hyperbolically arranged contact wires, which align themselves elastically as contact lines around the pin, providing a number of linear contact paths.

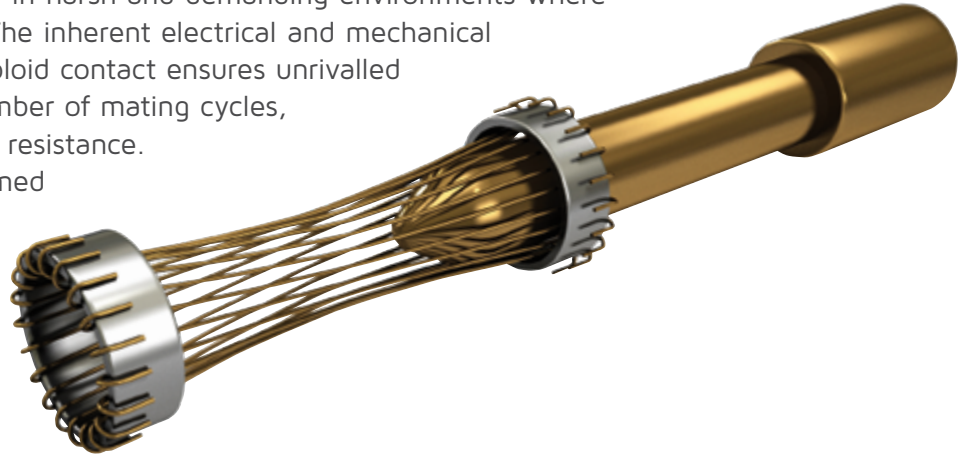

## Features

## Benefits

### Low insertion/extraction forces

The angle of the socket wires allows tight control of the pin insertion and extraction forces. The spring wires are smoothly deflected to make line contact with the pin.

### High density interconnect systems

Significant reductions in size and weight of sub-system designs. No additional hardware is required to overcome mating and unmating forces.

### Long contact life

The smooth and light wiping action minimizes wear on the contact surfaces. Contacts perform up to 100,000 insertion/extraction cycles with minimal degradation in performance.

### Low cost of ownership

The Hypertac contact technology will surpass most product requirements, thus eliminating the burden and cost of having to replace the connector or the entire subsystem.

### Lower contact resistance

The design provides a far greater contact area and the wiping action of the wires insures a clean and polished contact surface. Our contact technology has about half the resistance of conventional contact designs.

### Low power consumption

The lower contact resistance of our technology results in a lower voltage drop across the connector reducing the power consumption and heat generation within the system.

### Higher current ratings

The design parameters of the contact (e.g., the number, diameter and angle of the wires) may be modified for any requirement. The number of wires can be increased so the contact area is distributed over a larger surface. Thus, the high current carried by each wire because of its intimate line contact, can be multiplied many times.

### Maximum contact performance

The lower contact resistance of the Hypertac contact reduces heat build-up; therefore Hypertac contacts are able to handle far greater current in smaller contact assemblies without the detrimental effects of high temperature.

### Immunity to shock & vibration

The low mass and resultant low inertia of the wires enable them to follow the most abrupt or extreme excursions of the pin without loss of contact. The contact area extends 360° around the pin and is uniform over its entire length. The 3 dimensional symmetry of the Hypertac contact design guarantees electrical continuity in all circumstances.

### Reliability under harsh environments

Harsh environmental conditions require connectors that will sustain their electrical integrity even under the most demanding conditions such as shock and vibration. The Hypertac contact provides unmatched stability in demanding environments when failure is not an option.

# Contents

## KA Series

Technical Characteristics .....	3
Dimensions:	
2 & 3 Row Connectors .....	4
4 Row Connectors .....	7
5 Row Connectors .....	9
Terminal Styles:	
Style B.....	11
Style C.....	12
Style D/DD/FD.....	13
Style H2.....	14
Style R.....	14
Style S.....	15
Style W.....	15
Style Y.....	16
Replacement Contacts.....	17
Standard Mounting Hardware.....	18
Locking Hardware .....	23
Board Mounting Applications & Dimensions .....	28
Panel Cutouts:	
2 & 3 Row Connectors .....	33
4 & 5 Row Connectors .....	35
Accessories .....	36
How to Order.....	37
Military Part Number Cross Reference.....	38

# KA Series

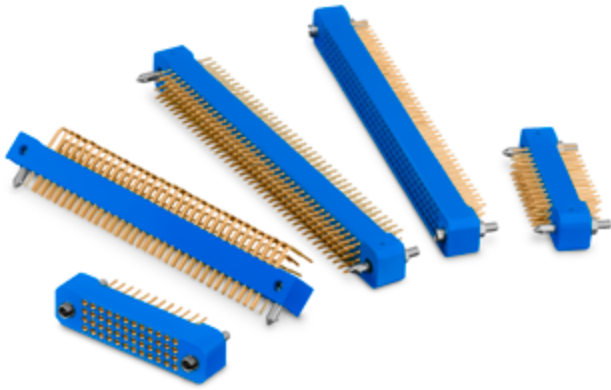

The KA Series connector family is part of Smiths Interconnect's portfolio of interconnect solutions designed and developed for rugged applications in the military, aerospace and commercial aviation markets. The KA Series is a highly engineered connector family that has gained a reputation for reliability under all varieties of extreme environmental conditions.

Utilizing the field-proven capabilities of the Hypertac® hyperboloid contact technology, the KA Series provides immunity to detrimental fretting due to shock and vibration, industry leading mating cycles and durability in a connector that meets the performance requirements of MIL-DTL-55302. With more than 2,500 configurations, the KA Series provides design flexibility not available with other MIL-DTL-55302 connectors. Additionally, the KA Series supports a current rating of 4 Amp per contact, low contact resistance and minimal insertion and extraction forces.

The technological innovation that Smiths Interconnect has designed into the KA Series enables it to provide a significant edge in demanding military, aerospace and commercial aviation operating environments where performance and reliability is essential.

**High reliability  
PCB connectors  
for demanding  
applications**

## Features & Benefits

**Meets performance requirements of MIL-DTL-55302**

### Design flexibility

- Ruggedized connector with straight through-hole solder, right angle PCB solder, crimp, solder cup, and Wire-Wrap® termination options
- Offered in 2 to 5 row configurations with pin counts from 17 to 490 contacts
- End guides provide alignment and 36 user-changeable keying combinations
- Male and female contacts and guides available in either plug or receptacle

**0.024 [0.60] diameter pins/sockets rated at 4 Amps**

**Pitch of 0.100 [2.54] on center**

- Adjacent rows offset by 0.05 [1.27] to allow straight printed circuit traces in 2 & 3 row connectors only

**Average insertion/extraction force of 1 oz. per contact**

**Contacts removable from wiring side**

- Front release, rear removable
- Front removable option available only on select contact configurations

# Technical Characteristics

	2 & 3 Row	4 & 5 Row
Number of Contacts	17, 29, 33, 41, 53, 62, 65, 72, 80, 84, 96, 98, 120, 126, 160	48, 68, 80, 96, 100, 108, 120, 125, 128, 136, 140, 160, 184, 196, 200, 208, 228, 230, 240, 264, 300, 320, 330, 352, 390, 392, 490
Pitch	0.100 [2.54]	
Contact Termination	Straight dip, right angle solder, crimp, solder cup and Wire Wrap® available	
Contact Diameter	0.024 [0.60]	

## Mechanical & Environmental

Temperature Rating	-55° to 125°C
Shock	Shock testing to MIL-DTL-55302 para. 4.5.14
Contact Life Cycles	100,000
Contact Resistance	< 5 mΩ
Extraction Force	0.30 to 2.00 oz. per contact

## Material & Finishes

Insulator	Diallyl-phthalate
Contact	Beryllium copper wires and brass body
Contact Plating	Gold over nickel <i>(tin-lead on PCB termination available)</i>
Guide Hardware	Brass/stainless steel
Guide Hardware Plating	Nickel/passivated stainless steel

## Electrical

Current Rating	4 A at 30°C rise	
DWV	1200 V RMS	1050 V RMS
Insulation Resistance	> 10 <sup>6</sup> MΩ at 500 VDC	
Breakdown Voltage Between Contacts	1600 V RMS	1400 V RMS

### Notes:

1) Wire Wrap is a trademark of Gardner Denver.

Dimensions are in inches [mm] | All content is subject to change without notice

# Dimensions *2 to 5 Row Connectors, 17 to 490 Contacts*

## 2 Row Connectors

17 to 65 Contacts

Plug

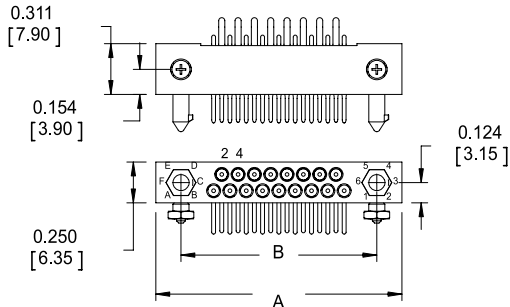

Receptacle

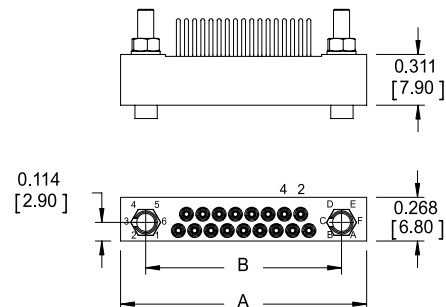

Contacts	A ±0.020 [0.50]	B	Mated pair
17	1.508 [38.30]	1.200 [30.48]	0.622 [15.80]
29	2.106 [53.54]	1.800 [45.72]	
33	2.308 [58.62]	2.000 [50.80]	
41	2.708 [68.78]	2.400 [60.96]	
53	3.308 [84.02]	3.000 [76.20]	
65	3.908 [99.26]	3.600 [91.44]	

## 3 Row Connectors

62, 80.1 & 98 Contacts

Plug

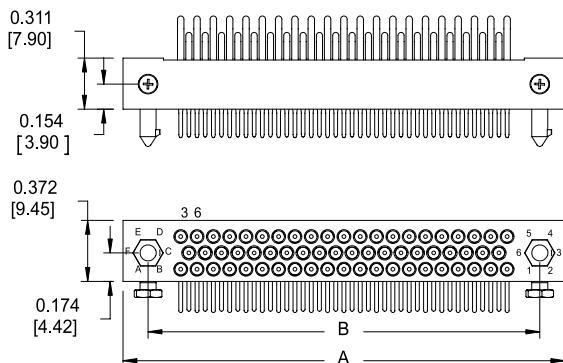

Receptacle

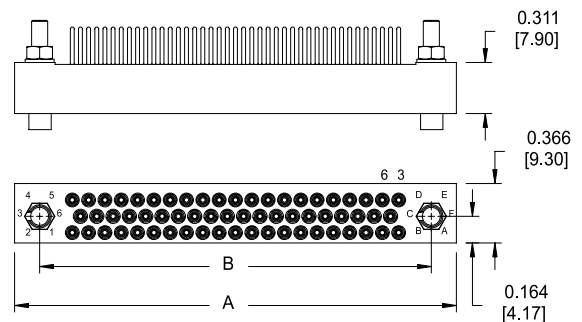

Contacts	A ±0.020 [0.50]	B	Mated pair
62	2.707 [68.75]	2.400 [60.96]	0.622 [15.80]
80.1	3.307 [84.00]	3.000 [76.20]	
98	3.907 [99.24]	3.600 [91.44]	

Dimensions are in inches [mm] | All content is subject to change witho

## 2 Row Connectors

72, 84, 96 & 120 Contacts

### Plug

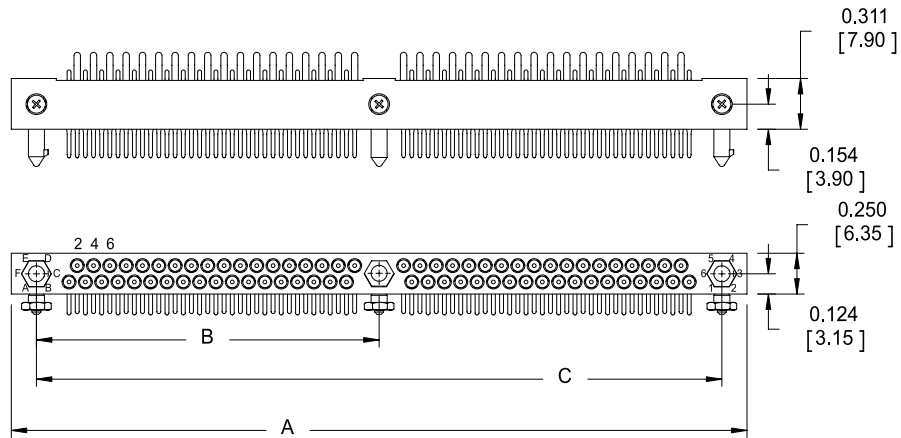

### Receptacle

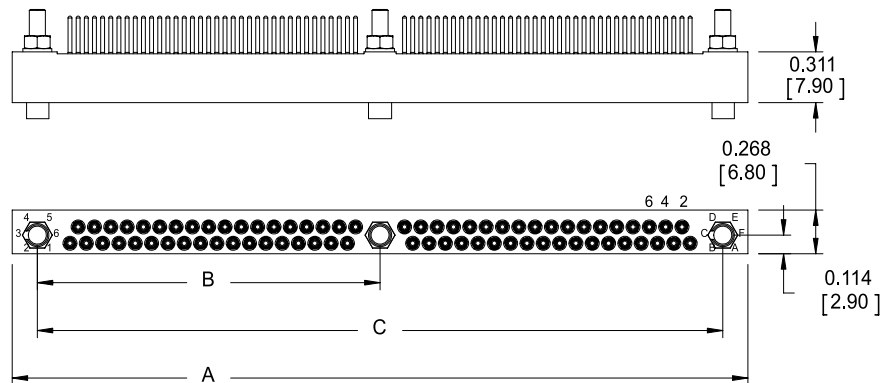

Contacts	A	B	C	Mated pair
72	4.508 [114.50]	2.100 [53.34]	4.200 [106.68]	0.622 [15.80]
84	5.108 [129.74]	2.400 [60.96]	4.800 [121.92]	
96	5.708 [144.98]	2.700 [68.58]	5.400 [137.16]	
120	6.908 [175.46]	3.300 [83.82]	6.600 [167.64]	

### 3 Row Connectors

#### 126 Contacts

Plug

Receptacle

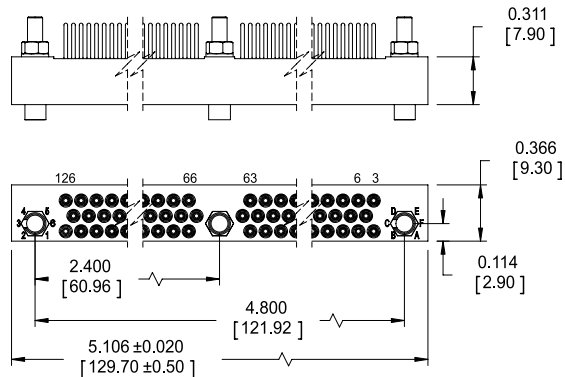
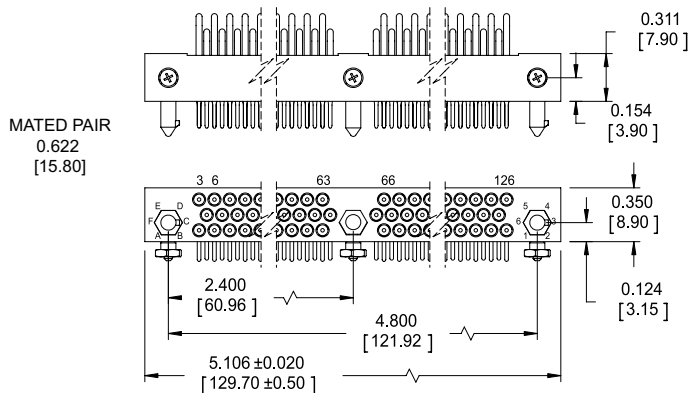

#### 160 Contacts

Plug

Receptacle

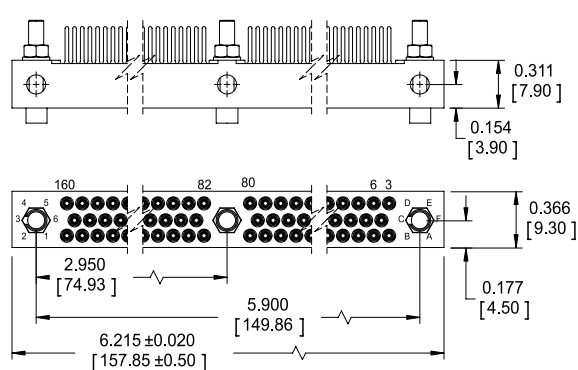
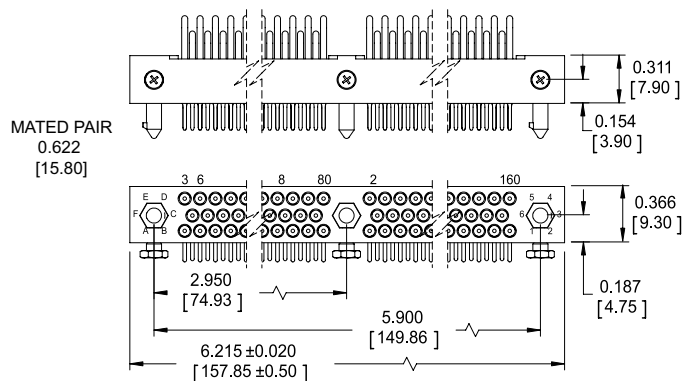

### 3 Row Connectors

160.4 Front Removable Contacts<sup>(1)(2)</sup>

#### Receptacle

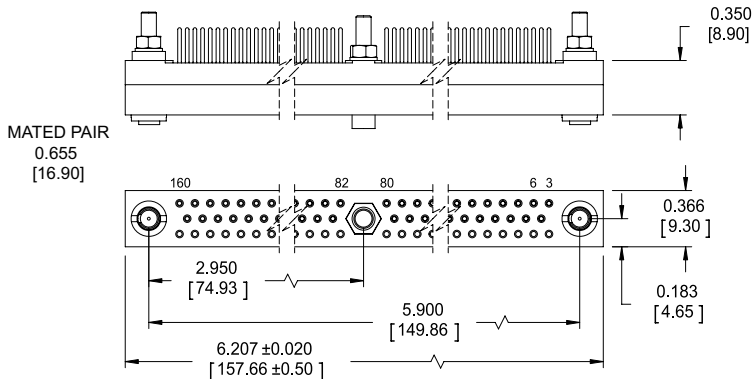

### 4 Row Connectors

48 to 228 Contacts

#### Plugs

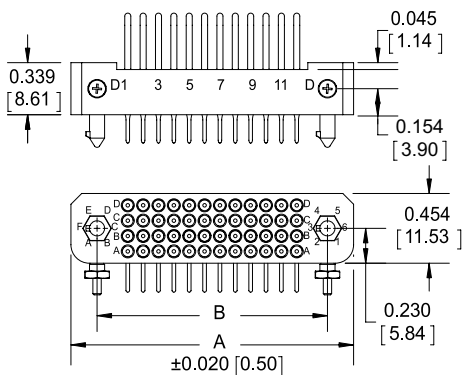

#### Receptacles

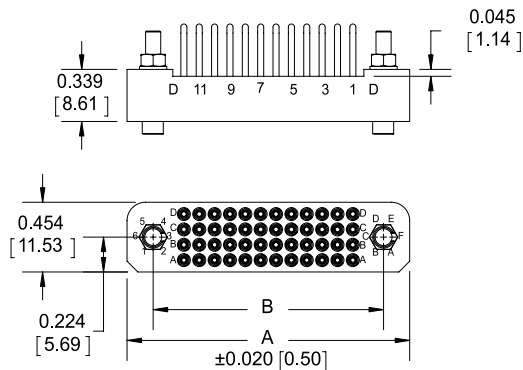

Contacts	A ±0.020 [0.50]	B	Mated pair
48	1.840 [46.74]	1.500 [38.10]	0.678 [17.22]
68	2.340 [59.44]	2.000 [50.80]	
80	2.640 [67.06]	2.300 [58.42]	
96	3.040 [77.22]	2.700 [68.58]	
100	3.140 [79.76]	2.800 [71.12]	
108	3.340 [84.84]	3.000 [76.20]	
120	3.640 [92.46]	3.300 [83.82]	
128	3.840 [97.54]	3.500 [88.90]	
136	4.040 [102.62]	3.700 [93.98]	
160	4.640 [117.86]	4.300 [109.22]	
184	5.240 [133.10]	4.900 [124.46]	
196	5.540 [140.72]	5.200 [132.08]	
228	6.340 [161.04]	6.000 [152.40]	

**Notes:**

- 1) Only available with straight dip solder (style "D") and Wire Wrap (style "Y") tails.
- 2) Mates with standard plug.

Dimensions are in inches [mm] | All content is subject to change without notice

# 4 Row Connectors

208, 240, 264, 352 & 392 Contacts

## Plugs

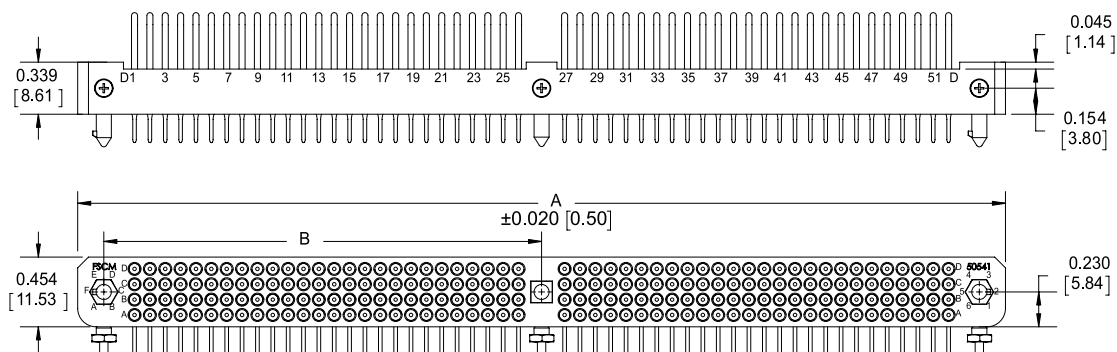

## Receptacles

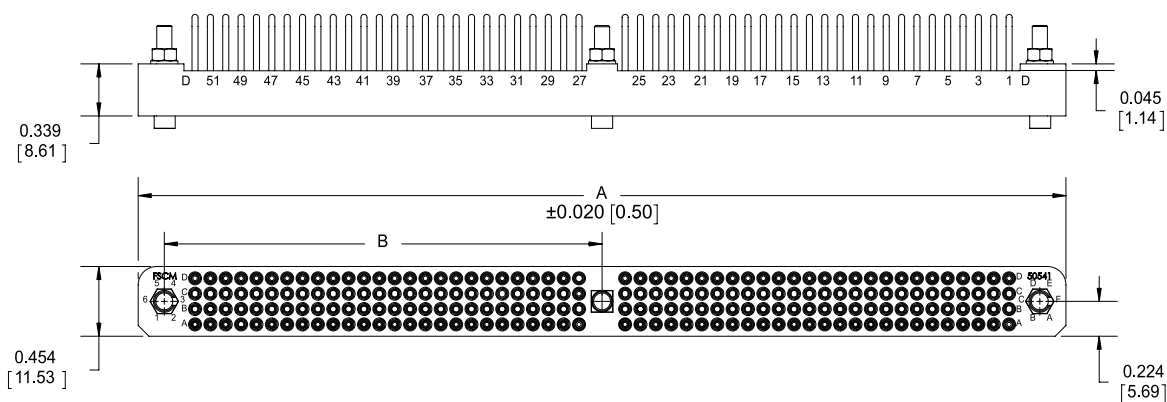

Contacts	A ±0.020 [0.50]	B	Mated pair
208	6.040 [153.42]	2.850 [72.39]	0.678 [17.22]
240	6.840 [173.74]	3.250 [82.55]	
264	7.438 [188.92]	3.550 [90.17]	
352	9.640 [244.86]	4.650 [118.11]	
392	10.640 [270.26]	5.150 [130.81]	

**Notes:**

1) For insulators longer than 7.00 [178.00], a mother board-daughter board configuration is highly recommended.

Dimensions are in inches [mm] | All content is subject to change without notice

# 5 Row Connectors

125, 140, 160, 200, 230 & 240 Contacts

## Plugs

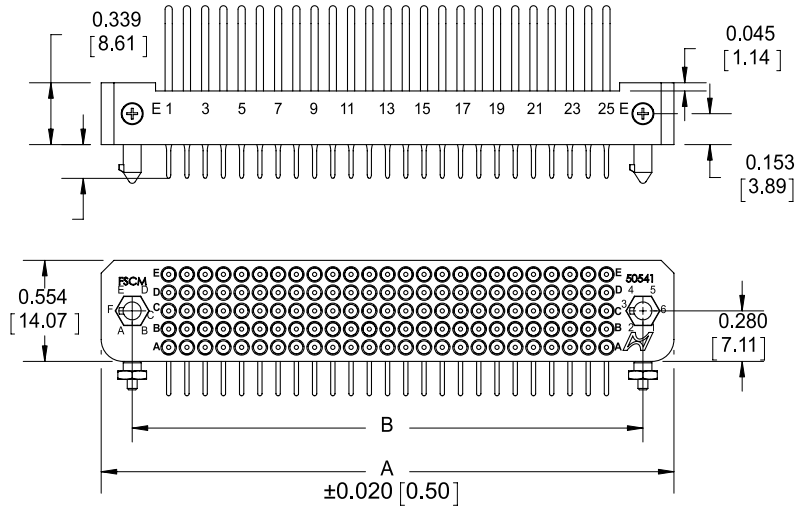

## Receptacles

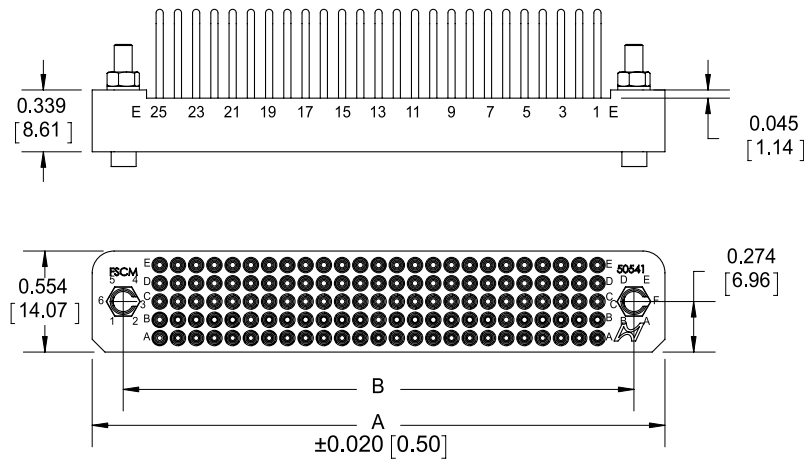

Contacts	A ±0.020 [0.50]	B	Mated pair
125	3.140 [79.76]	2.850 [72.39]	0.678 [17.22]
140	3.440 [87.38]	3.100 [78.74]	
160	3.840 [97.54]	3.500 [88.92]	
200	4.640 [117.86]	4.300 [109.22]	
230	5.240 [133.10]	4.900 [124.46]	
240	5.440 [138.10]	5.100 [129.54]	

# 5 Row Connectors

300, 320, 330, 390 & 490 Contacts

## Plugs

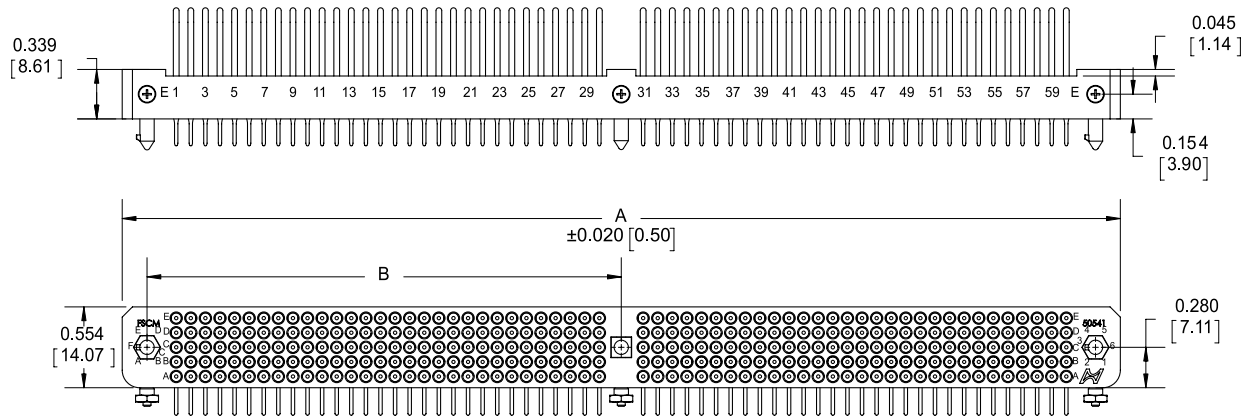

## Receptacles

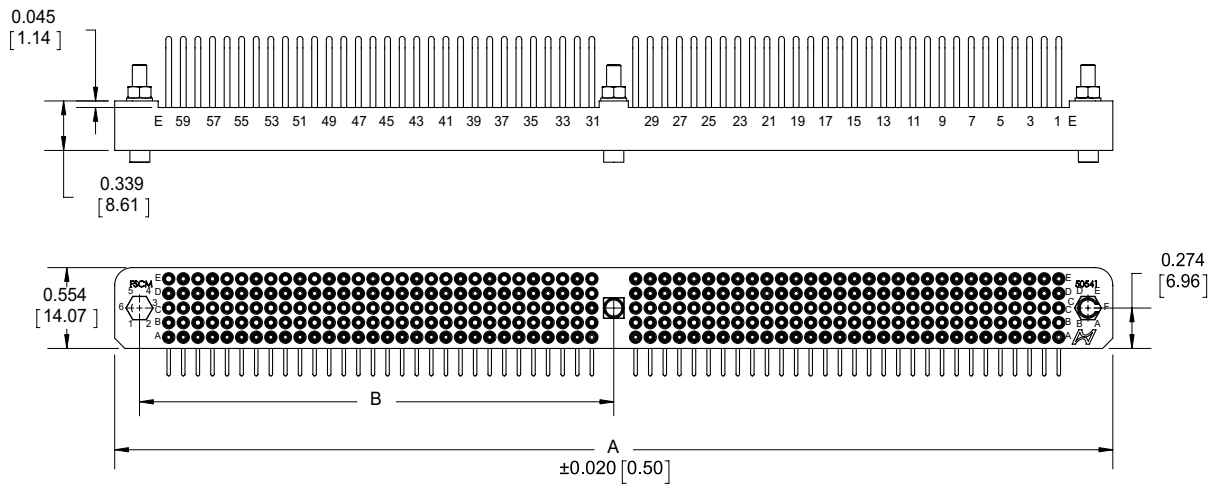

Contacts	A ±0.020 [0.50]	B	Mated pair
300	6.840 [173.74]	3.250 [82.55]	0.678 [17.22]
320	7.240 [183.90]	3.450 [87.63]	
330	7.440 [188.98]	3.550 [90.17]	
390	8.640 [219.46]	4.150 [105.41]	
490	10.640 [270.26]	5.150 [130.81]	

**Notes:**

1) For insulators longer than 7.00 [178.00], a mother board-daughter board configuration is highly recommended.

Dimensions are in inches [mm] | All content is subject to change without notice

# Termination Styles *Dimensions & Specifications<sup>(1)</sup>*

## Style B

Right Angle Through-Hole Solder  
For 0.125 [3.18] PC board

Terminations (female or male)		Rows	Configurations	A	B	C	D
Plugs	Receptacles						
		2 Row	All (17 to 120)	-	-	-	-
		3 Row	62, 80.1, 98 & 126	0.191 [4.86]	0.200 [5.08]	0.201 [5.11]	0.354 [8.98]
			160	0.178 [4.53]	0.188 [4.78]	0.188 [4.78]	0.342 [8.68]
		4 Row	All (48 to 392)	-	-	-	-
		5 Row	All (125 to 490)	-	-	-	-

**Notes:**

1) All tail lengths are ± 0.015 [0.40] long.

Dimensions are in inches [mm] | All content is subject to change without notice

## Style C

### Right Angle Through-Hole Solder

For 0.063 [1.59] PC board

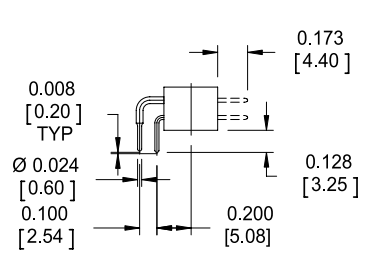
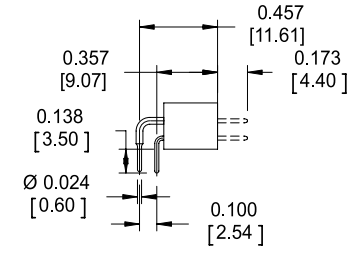
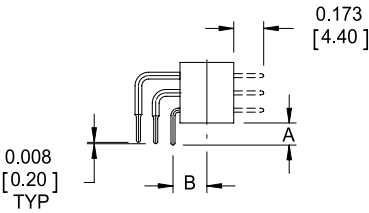
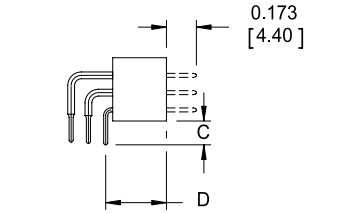
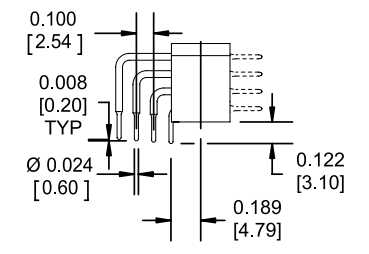
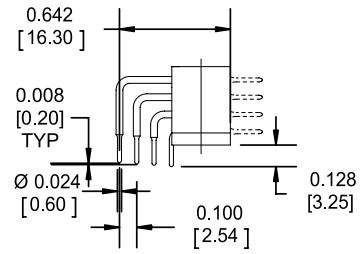
Terminations ( <i>female or male</i> )		Rows	Configurations	A	B	C	D
<b>Plugs</b>	<b>Receptacles</b>						
		2 Row	All (17 to 120)	-	-	-	-
		3 Row	62, 80.1, 98 & 126	0.128 [3.25]	0.200 [5.08]	0.138 [3.50]	0.354 [8.98]
			160	0.115 [2.92]	0.188 [4.78]	0.125 [3.17]	0.342 [8.68]
		4 Row	All (48 to 392)	-	-	-	-
		5 Row	All (125 to 490)	-	-	-	-

## Style D/DD/FD

### Straight Through-Hole Solder

For 0.125 [3.18] PC board

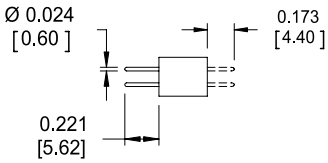
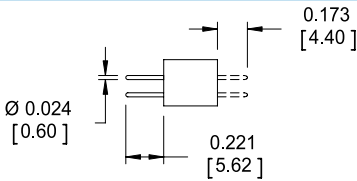
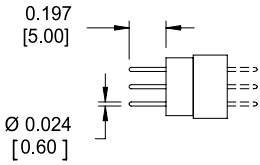
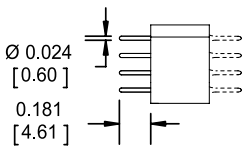
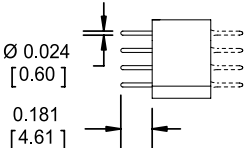
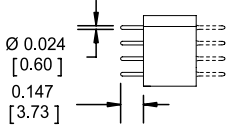
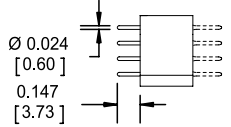
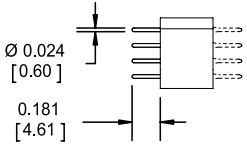
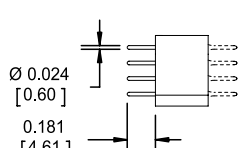
Terminations ( <i>female or male</i> )		Style	Rows	Configurations
Plugs	Receptacles			
		D	2 Row	All (17 to 120)
			3 Row	All (62 to 160)
-		D <i>0.4 front removable version</i>	3 Row	160
		D	4 Row	All (48 to 392)
			5 Row	All (125 to 490)
		DD <sup>(1)</sup>	4 Row	All (48 to 392)
			5 Row	All (125 to 490)
		FD <sup>(1)</sup> <i>front removable version</i>	4 Row	160
			5 Row	160

**Notes:**

1) Consult factory for availability

Dimensions are in inches [mm] | All content is subject to change without notice

## Style H2

Double Solder Cup (for insulation)

Accepts 22 to 26 AWG wire stripped back 0.146 [3.70]

Terminations (female or male)		Wire gauge	Rows	Configurations
Plugs	Receptacles			
		22, 24 & 26 AWG	2 Row	All (17 to 120)
			3 Row	All (62 to 160)
		22 & 26 AWG	4 Row	All (48 to 392)
			5 Row	All (125 to 490)

## Style R

Crimp<sup>(1)</sup>

Accepts 22, 24 and 26 AWG wire stripped back 0.173 [4.40]

Terminations (female or male)		Wire gauge	Rows	Configurations
Plug	Receptacles			
		22, 24 & 26 AWG	2 Row	All (17 to 120)
			3 Row	All (62 to 160)
		22, 24 & 26 AWG	4 Row	All (48 to 392)
			5 Row	All (125 to 490)

**Notes:**

1) Crimp contacts will be shipped unmounted. When inserting into the blocks/insulators be sure that the rear is aligned with the flats in the insulator.

Dimensions are in inches [mm] | All content is subject to change without notice

## Style S

### Solder Cup

Accepts up to 22 AWG wire stripped back 0.126 [3.20]

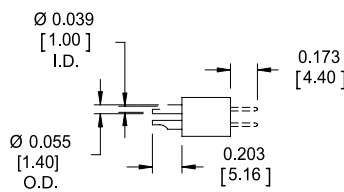
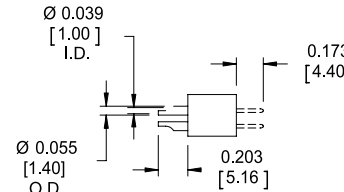
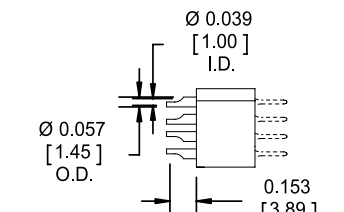
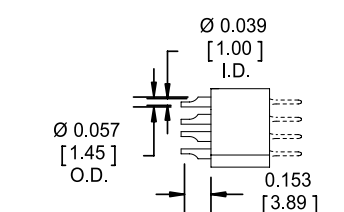
Terminations (female or male)		Wire gauge	Rows	Configurations
Plugs	Receptacles			
		22, 24 & 26 AWG	2 Row	All (17 to 120)
			3 Row	All (62 to 160)
		22 & 26 AWG	4 Row	All (48 to 392)
			5 Row	All (125 to 490)

## Style W<sup>(2)</sup>

### Wire Wrap<sup>®</sup> (2 wraps)

Accepts 28 and 30 AWG wire

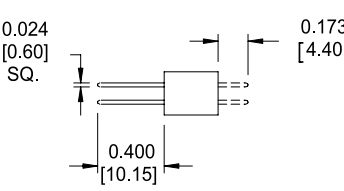
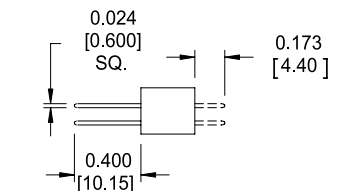
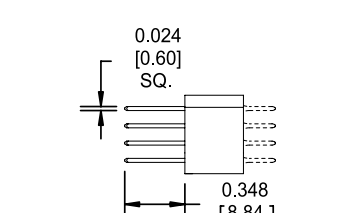
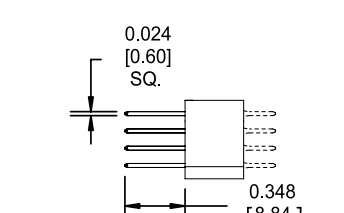
Terminations (female or male)		Wire gauge	Rows	Configurations
Plugs	Receptacles			
		28 & 30 AWG	2 Row	All (17 to 120)
			3 Row	All (62 to 160)
		28 & 30 AWG	4 Row	All (48 to 392)
			5 Row	All (125 to 490)

**Notes:**

- 1) Solder cup access cut-aways will be oriented staggered as shown for commercial parts. Connectors ordered to "D55302" style part numbers have all cut-aways oriented in the same direction.
- 2) Consult factory for availability.

Dimensions are in inches [mm] | All content is subject to change without notice

## Style Y<sup>(1)</sup>

Wire Wrap<sup>®</sup> (2 or 3 wraps)

Accepts 24 to 30 AWG wire

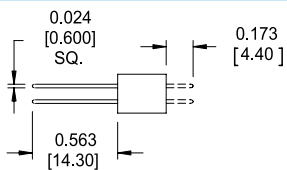
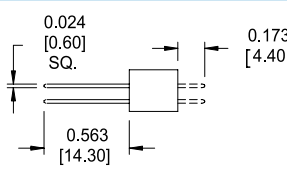
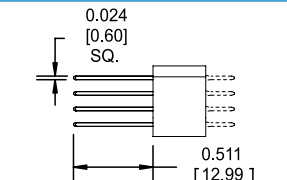
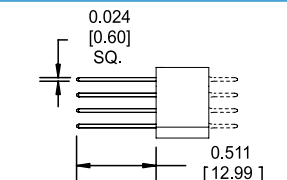
Terminations (female or male)		Rows	Configurations	Wraps	Wire gauge
Plugs	Receptacles				
		2 Row	All (17 to 120)	2 Wraps 3 Wraps	24 & 26 AWG 28 & 30 AWG
		3 Row	All (62 to 160)	2 Wraps 3 Wraps	24 & 26 AWG 28 & 30 AWG
		4 Row	All (48 to 392)	2 Wraps 3 Wraps	24 & 26 AWG 28 & 30 AWG
		5 Row	All (125 to 490)	2 Wraps 3 Wraps	24 & 26 AWG 28 & 30 AWG

# Replacement Contacts *Part Number Reference*

Style	Rows	Standard sockets	Standard pins	Beryllium copper pins
<b>B</b>	Row 1	YSK006-028AH	YPN006-034G or H	YPN006-072H
	Row 2	YSK006-029AH	YPN006-035G or H	YPN006-075H
	Row 3	YSK006-030AH	YPN006-036G or H	YPN006-073H
	Row 4	YSK006-074AH	YPN006-148G or H	—
	Row 5	YSK006-094AH	YPN006-172G or H	—
<b>C</b>	Row 1	YSK006-013AH	YPN006-023G or H	YPN006-048H
	Row 2	YSK006-006AH	YPN006-016G or H	YPN006-050H
	Row 3	YSK006-014AH	YPN006-024G or H	YPN006-077H
	Row 4	YSK006-090AH	YPN006-159G or H	—
	Row 5	YSK006-092AH	YPN006-171G or H	—
<b>D</b>	All	YSK006-005ANH <sup>(2)</sup>	YPN006-015G or H	YPN006-049H
<b>DD</b>	All	YSK006-096ANH	YPN006-106G or H	—
<b>FD<sup>(3)</sup></b>	All	YSK006-274AH	YPN006-470G or H	YPN006-487H
<b>H2</b>	All	YSK006-009AH	YPN006-019G or H	—
<b>R</b>	All	YSK006-011ANH	YPN006-021G or H	—
<b>S</b>	All	YSK006-010ANH	YPN006-020G or H	—
<b>W</b>	All	YSK006-020AH	YPN006-039G or H	—
<b>Y</b>	All	YSK006-012AH	YPN006-022G or H	—

**Notes:**

- 1) Consult factory for availability
- 2) Front removable version: YSK006-027AH
- 3) Front removable contact for standard housing

Dimensions are in inches [mm] | All content is subject to change without notice

# Standard Mounting Hardware *Style & Dimensions*

## Style 10

### Plug Only

Recommended for B and C contact terminations (*H2, R and S optional*)

#### 2 & 3 Row

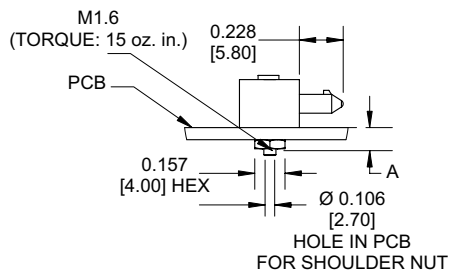

#### 4 & 5 Row

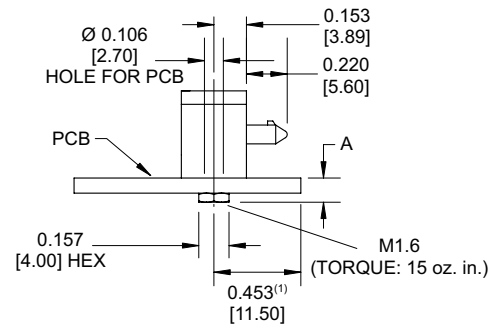

Contacts	A	
	Termination B	Termination C
2 ROW	0.191 [4.85]	0.124 [3.15]
3 ROW	0.220 [5.59] (KA160: 0.207 [5.25])	0.141 [3.58] (KA160: 0.128 [3.25])
4 ROW	0.203 [5.16]	0.164 [4.16]
5 ROW	0.232 [5.89]	0.153 [3.89]

## Style 11

### Plug/Receptacle

Recommended for D, H2, R and S contact terminations (*W and Y optional*)

#### 2 & 3 Row

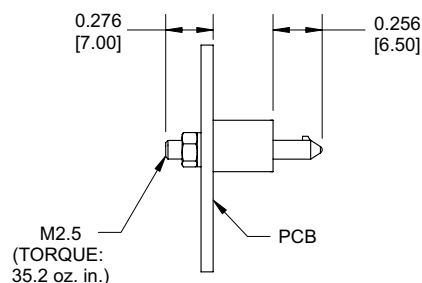

#### 4 & 5 Row

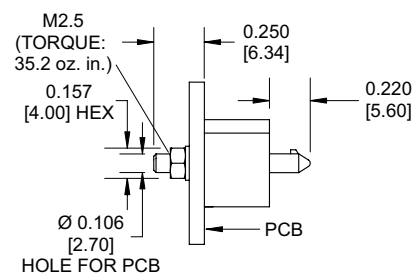

#### Notes:

1) PCB may be extended to 0.453 [11.50] max. for use as a pin protector.

Dimensions are in inches [mm] | All content is subject to change without notice

## Style 12

### Plug Only

Recommended for D contact terminations only

2 Row only

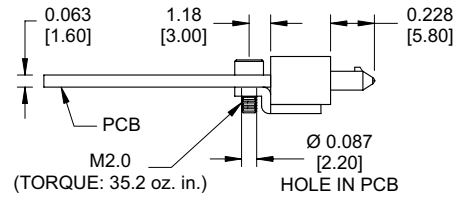

## Style 13 | Float Mounting

### Plug/Receptacle

Recommended for H2, R and S contact terminations

Radial float is 0.020 [0.50] from center

2 & 3 Row

4 & 5 Row

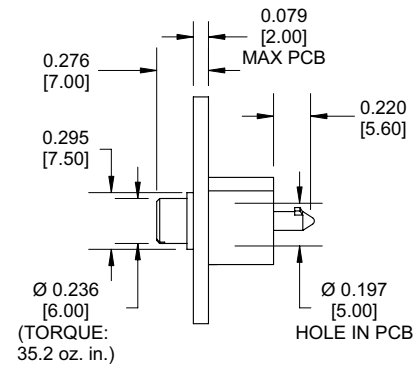
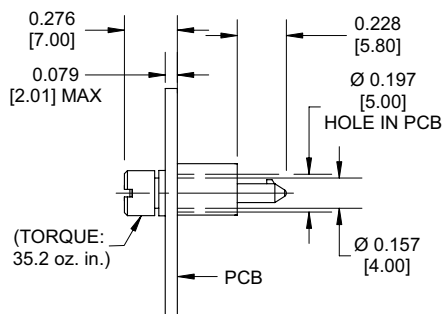

## Style 14

### Receptacle Only

Recommended for B and C contact terminations (H2, R and S optional)

2 & 3 Row

4 & 5 Row

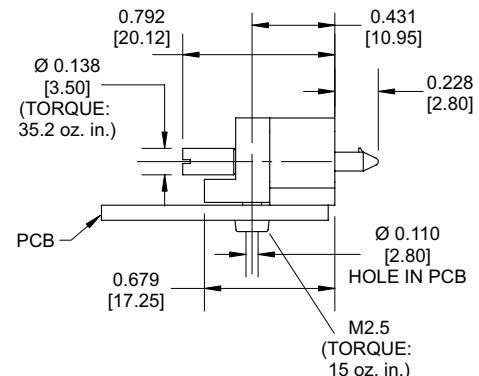
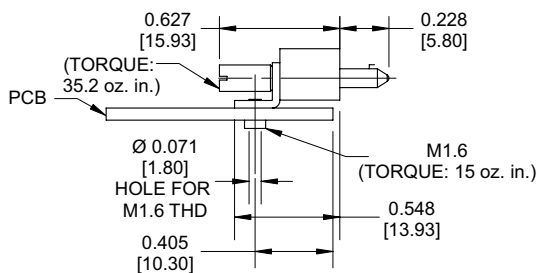

## Style 21

### Plug/Receptacle

Recommended for D, H2, R and S contact terminations (*W and Y optional*)

2 & 3 Row

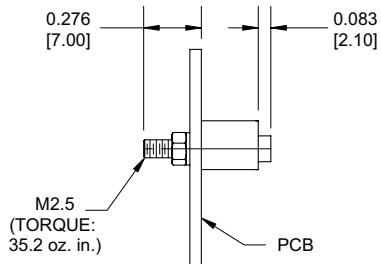

4 & 5 Row

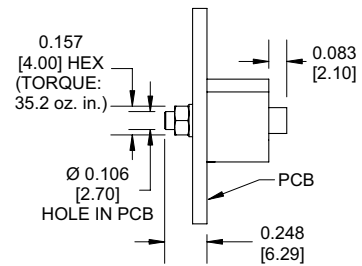

## Style 23 / Float Mounting

### Plug/Receptacle

Recommended for D, H2, R and S contact terminations (*W and Y optional*)

2 & 3 Row

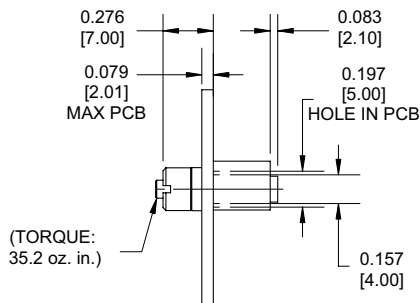

4 & 5 Row

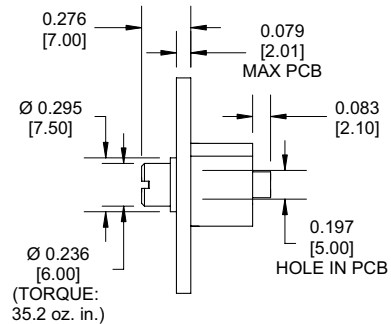

## Style 24

### Plug/Receptacle

Recommended for B and C contact terminations (*H2, R and S optional*)

2 & 3 Row

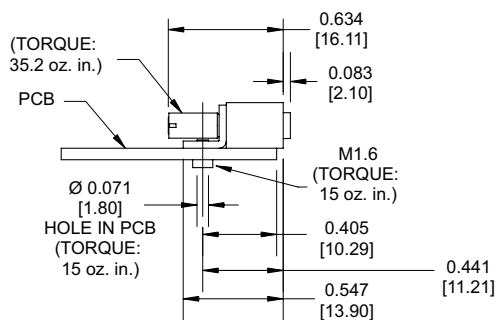

4 & 5 Row

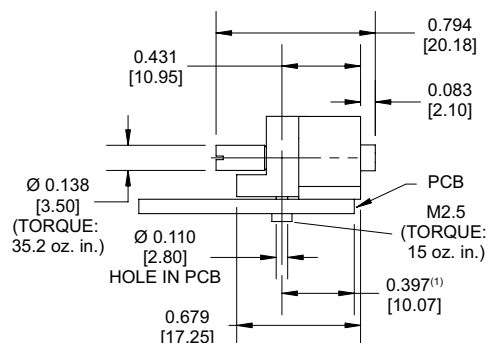

**Notes:**

1) PCB may be extended to 0.453 [11.50] max. for use as a pin protector.

Dimensions are in inches [mm] | All content is subject to change without notice

## Style 101

### Plug Only

Recommended for B and C contact terminations (*H2, R and S optional*)

#### 2 & 3 Row

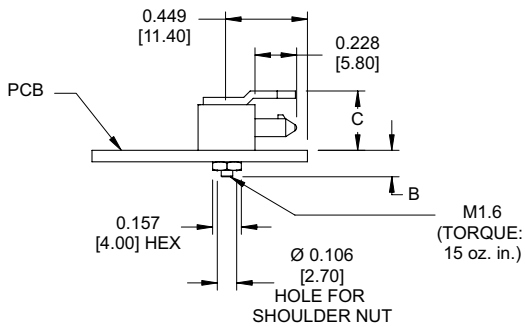

#### 4 & 5 Row

(with pin protector)

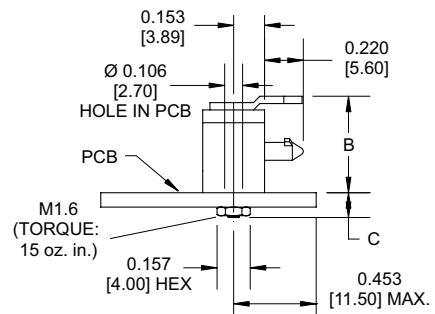

Contacts	B		C
	Termination B	Termination C	
2 ROW	0.204 [5.18]	0.165 [4.18]	0.343 [8.71]
3 ROW	0.218 [5.53] (KA160: 0.205 [5.20])	0.139 [3.53] (KA160: 0.126 [3.20])	0.447 [11.36]
4 ROW	0.541 [13.74]		0.168 [4.26]
5 ROW	0.661 [16.78]		0.236 [5.91]

## Style 111

### Plug Only

Recommended for B and C contact terminations (*W and Y optional*)

#### 2 & 3 Row

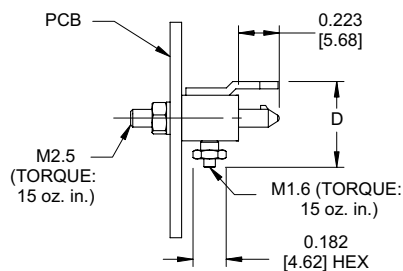

#### 4 & 5 Row

(with pin protector)

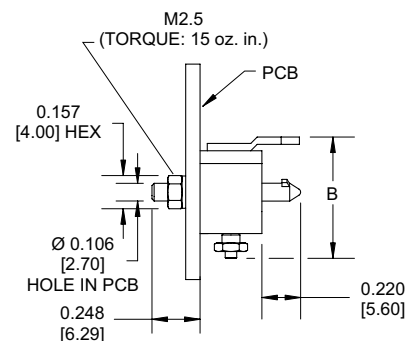

Contacts	B	D
2 ROW	—	0.486 [11.89]
3 ROW	—	0.586 [14.89]
4 ROW	0.781 [19.84]	—
5 ROW	0.900 [22.86]	—

**Notes:**

1) Right angle mounting screw length is determined by contact terminal length.

Dimensions are in inches [mm] | All content is subject to change without notice

## Style 121

### Plug Only

Recommended for D contact terminations only

2 Row only

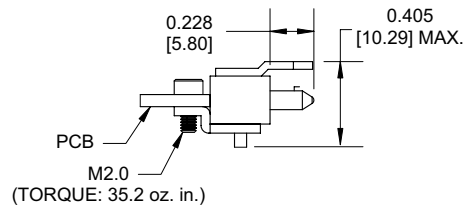

## Style 131 / Float Mounting

### Plug Only

Recommended for H2, R and S contact terminations

2 & 3 Row

(with pin protector)

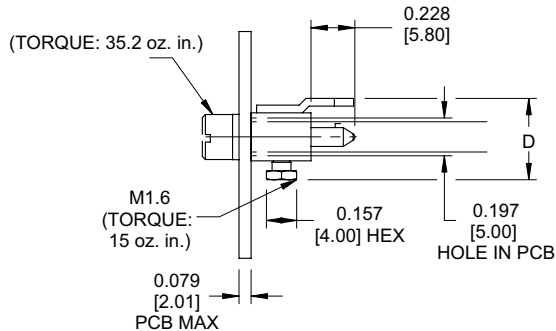

4 & 5 Row

(with pin protector)

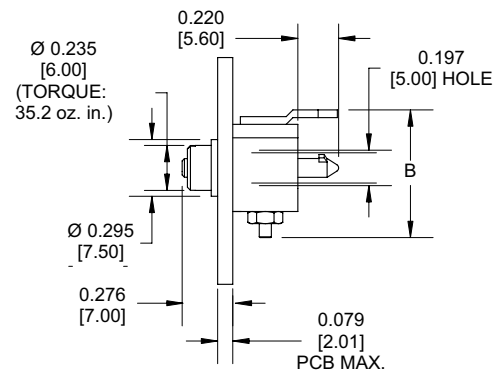

Contacts	B	D
2 ROW	—	0.486 [11.89]
3 ROW	—	0.586 [14.89]
4 ROW	0.781 [19.84]	—
5 ROW	0.900 [22.86]	—

# Locking Hardware *Styles & Dimensions*

## Style V1

### Plug/Receptacle

Push, quarter turn locking method  
Recommended for H2, R and S contact terminations

**2 & 3 Row**  
*Mates with V2 & V4*

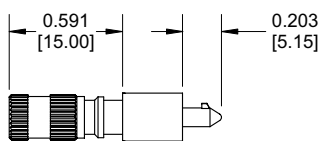

**4 & 5 Row**  
*Mates with V2 & V4*

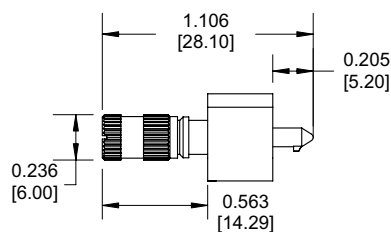

## Style V2

### Plug/Receptacle

Push, quarter turn locking method  
Recommended for D, H2, R and S contact terminations (*W and Y optional*)

**2 & 3 Row**  
*Mates with V1, V3 & V6*

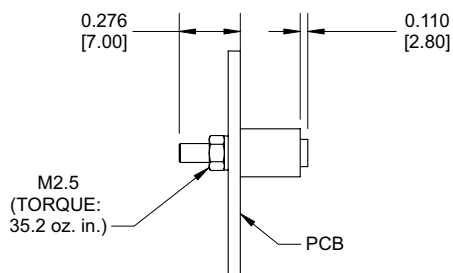

**4 & 5 Row**  
*Mates with V1 & V6*

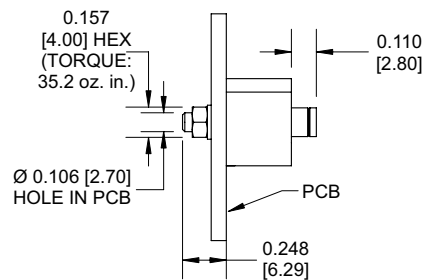

## Style V3

### Plug Only

Push, quarter turn locking method

Recommended for B and C contact terminations (*H2, R and S optional*)

2 & 3 Row only

Mates with V2 & V4

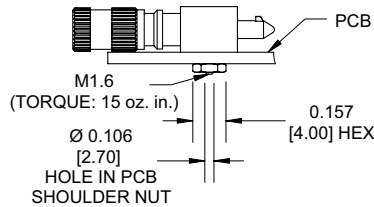

## Style V4

### Plug/Receptacle

Push, quarter turn locking method

Recommended for B and C contact terminations (*H2, R and S optional*)

2 & 3 Row

Mates with V1, V3 & V6

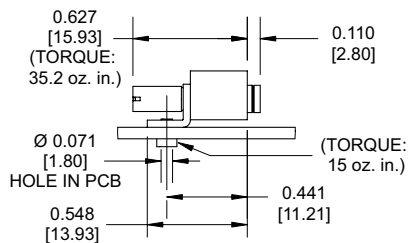

4 & 5 Row

Mates with V1 & V6

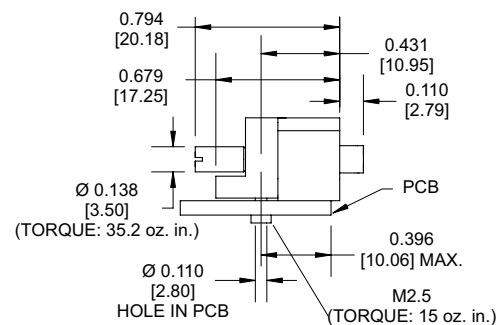

## Style V6

### Plug Only

Push, quarter turn locking method

Recommended for B and C contact terminations (*H2, R and S optional*)

2 & 3 Row

Mates with V2 & V4

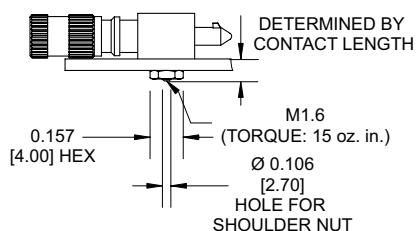

4 & 5 Row

Mates with V2 & V4

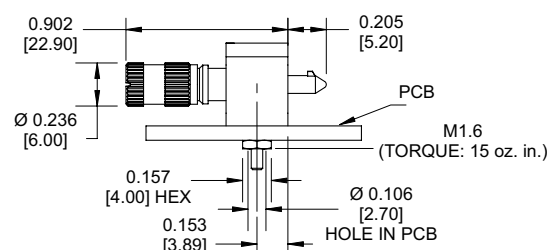

## Style V7

### Plug/Receptacle

Screw locking method

Recommended for H2, R and S contact terminations

#### 2 & 3 Row

Mates with V8, V9 and V15

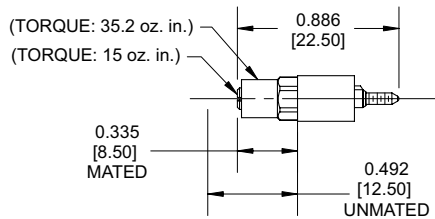

#### 4 & 5 Row

Mates with V9 & V15

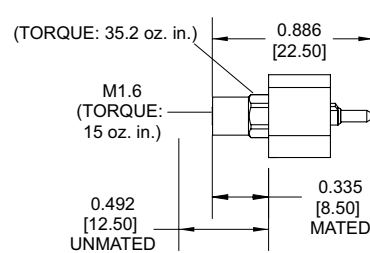

## Style V8

### Plug Only

Screw locking method

Recommended for B and C contact terminations (H2, R and S optional)

#### 2 & 3 Row only

Mates with V7<sup>(1)</sup>

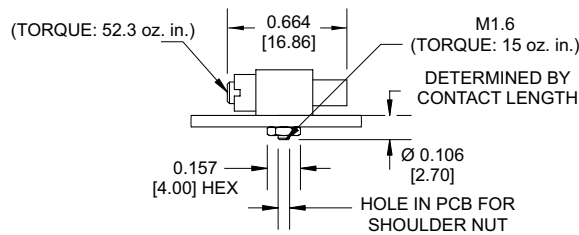

## Style V9

### Plug Only

Screw locking method

Recommended for B and C contact terminations (H2, R and S optional)

#### 2 & 3 Row

Mates with V7<sup>(1)</sup>

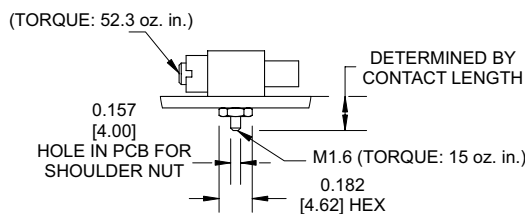

#### 4 & 5 Row

Mates with V7

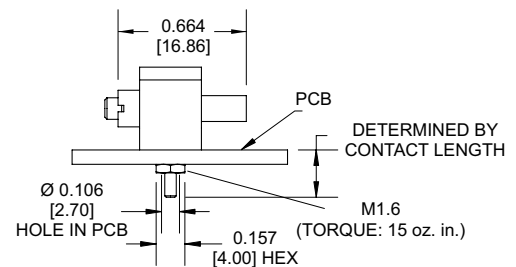

**Notes:**

- 1) For contact configurations: 62, 80.1, 98 and 160
  - 2) Right angle mounting screw length is determined by contact terminal length
- Dimensions are in inches [mm] | All content is subject to change without notice

## Style V15

Plug/Receptacle

Screw locking method

Recommended for D, H2, R and S contact terminations (*W and Y optional*)

2 & 3 Row

Mates with V7

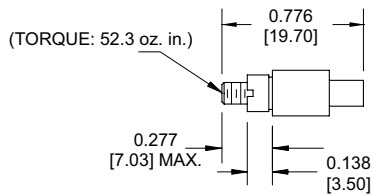

4 & 5 Row

Mates with V7

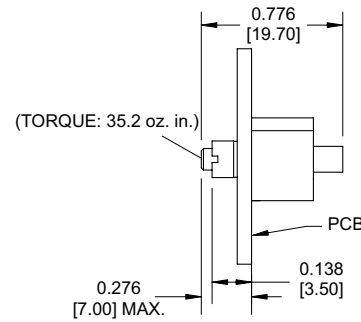

## Style V30 | Stationary Jackscrew

Plug Only

Screw locking method

Recommended for B and C contact terminations (*H2, R and S optional*)

2 & 3 Row

Mates with V33

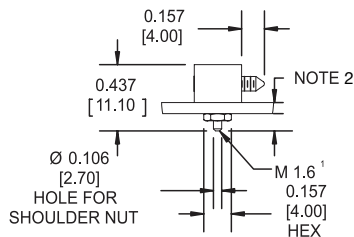

4 & 5 Row

Mates with V33

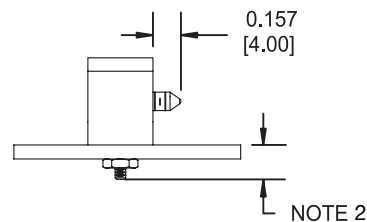

## Style V31 | Stationary Jack Socket

Plug/Receptacle

Screw locking method

Recommended for D, H2, R and S contact terminations (*W and Y optional*)

2 & 3 Row

Mates with V32

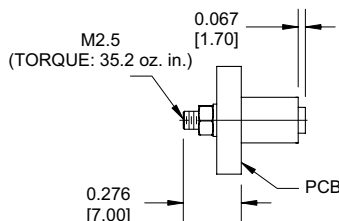

4 & 5 Row

Mates with V32

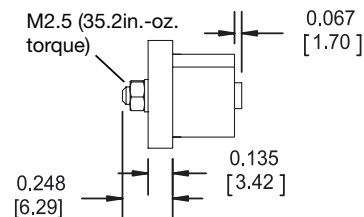

**Notes:**

- 1) 15.00 oz. in torque.
  - 2) Right angle mounting screw length is determined by contact terminal length.
- Dimensions are in inches [mm] | All content is subject to change without notice

## Style V32 | Rotating Jackscrew

Plug/Receptacle

Screw locking method

Recommended for D, H2, R and S contact terminations (*W and Y optional*)

2 & 3 Row

Mates with V31 & V33

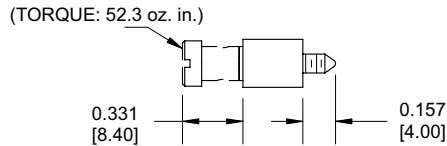

4 & 5 Row

Mates with V31 & V33

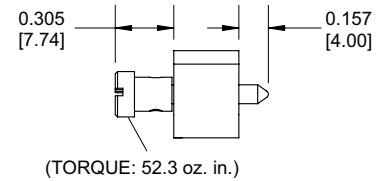

## Style V33 | Rotating Jack Socket

Plug/Receptacle

Screw locking method

Recommended for D, H2, R and S contact terminations (*W and Y optional*)

2 & 3 Row

Mates with V30 & V32

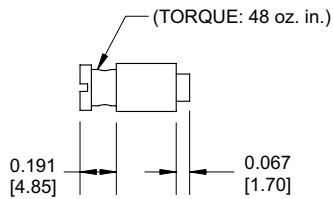

4 & 5 Row

Mates with V30 & V32

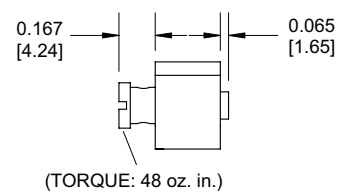

# Board Mounting *Applications & Dimensions*

## 2 Row Connectors

17, 29, 33, 41, 53 & 65 Contacts

PC board shown from component side of board

Contacts	B
17	1.200 [30.48]
29	1.800 [45.72]
33	2.000 [50.8]
41	2.400 [60.96]
53	3.000 [76.20]
65	3.600 [91.44]

### Mother board application

Style 11, 21, V2, V15 & V31

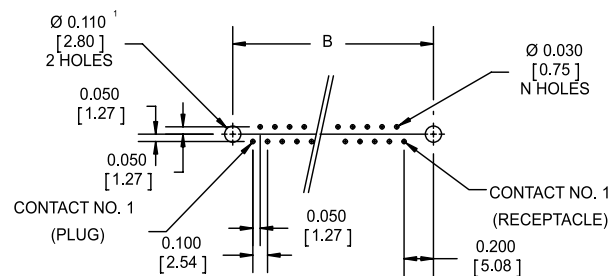

### Daughter board application

Style 10, 30, V3, V8 & V30

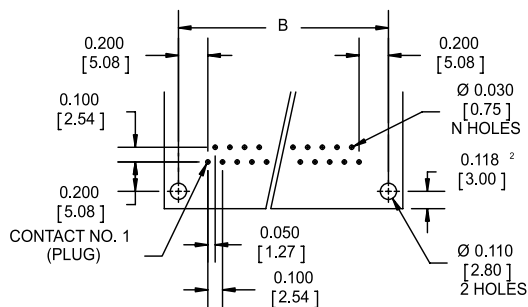

### Daughter board application

Style 24 & V4

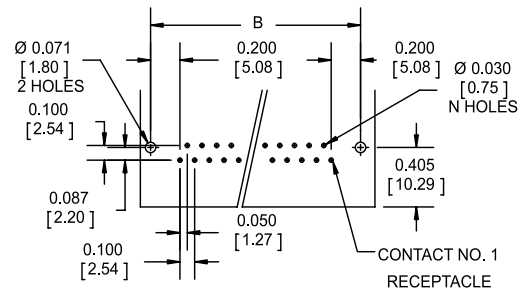

#### Notes:

- 1) For V15 locking mounting style, dimension is  $0.130 \pm 0.004$  [3.20 ± 0.10] diameter.
- 2) PC board may be extended to 0.453 [11.50] max for use as a pin protector.

Dimensions are in inches [mm] | All content is subject to change without notice

### 3 Row Connectors

62, 80.1 & 98 Contacts

PC Board shown from component side of board

Contacts	B
62	2.400 [60.96]
80.1	3.000 [76.20]
98	3.600 [91.44]

#### Mother board application

Style 11, 21, V2, V15 & V31

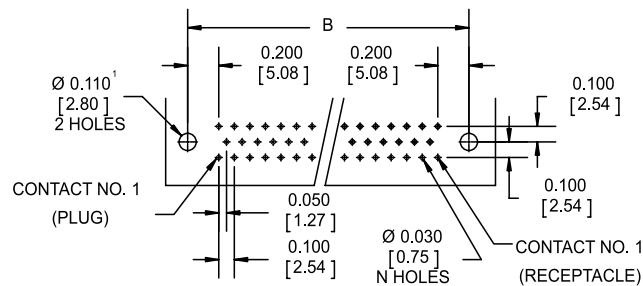

#### Daughter board application

Style 10, 30, V3, V8 & V30

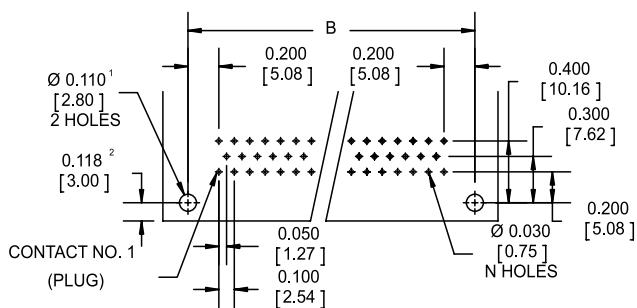

#### Daughter board application

Style 24 & V4

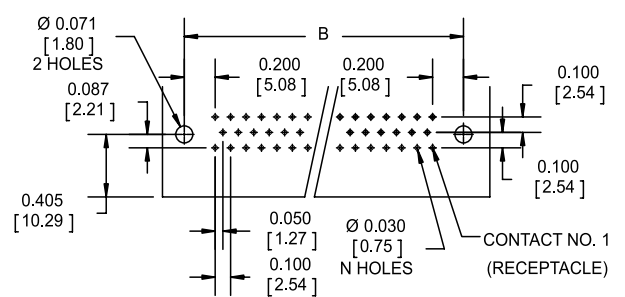

**Notes:**

- 1) For V15 locking mounting style, dimension is 0.130 ± 0.004 [3.20 ± 0.10] diameter.
- 2) PC board may be extended to 0.453 [11.50] max for use as a pin protector.

Dimensions are in inches [mm] | All content is subject to change without notice

## 2 & 3 Row Connectors

72, 84, 96, 120 & 126 Contacts

PC Board shown from component side of board

Contacts	B	C
72	2.100 [53.34]	4.200 [106.68]
84	2.400 [60.96]	4.800 [121.92]
96	2.700 [68.58]	5.400 [137.16]
120	3.300 [83.82]	6.600 [167.64]
126	2.400 [60.96]	4.800 [121.92]

### Mother board application

Style 11, 21, V2, V15 & V31

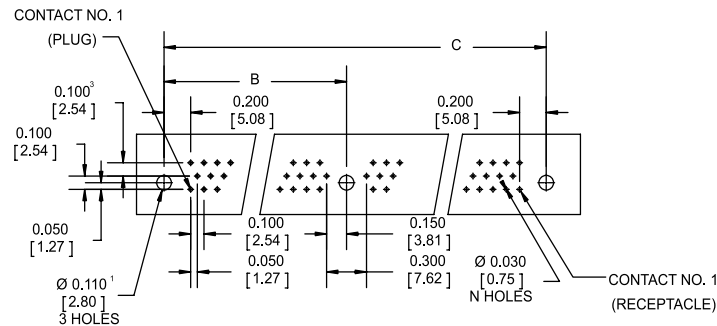

### Daughter board application

Style 10, 30, V3, V8 & V30

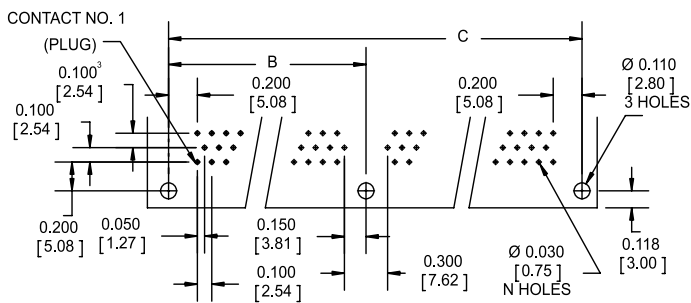

### Daughter board application

Style 24 & V4

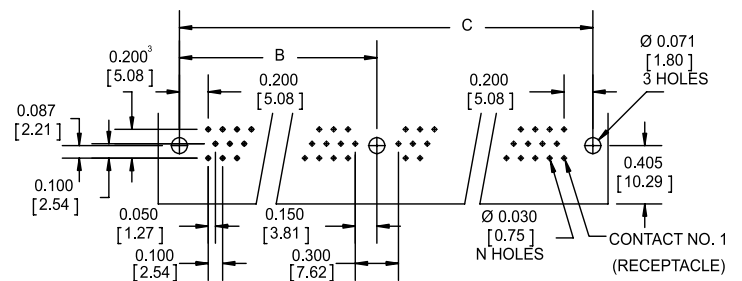

#### Notes:

- 1) For V15 locking mounting style, dimension is  $0.130 \pm 0.004$  [3.20 ± 0.10] diameter.
- 2) PC board may be extended to 0.453 [11.50] max for use as a pin protector.
- 3) Third row is for 126 pin version only.

Dimensions are in inches [mm] | All content is subject to change without notice

### 3 Row Connectors

#### 160 & 160.4 Contacts

PC Board shown from component side of board

Contacts	B	C
160	2.950 [74.93]	5.900 [149.86]
160.4	2.950 [74.93]	5.900 [149.86]

#### Mother board application

Style 11, 21, V2, V15 & V31

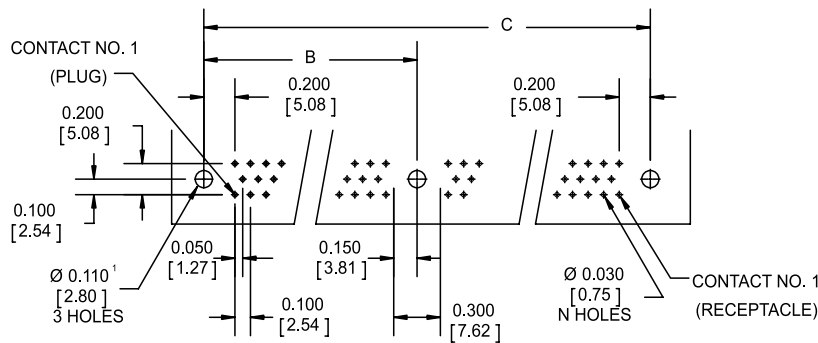

#### Daughter board application

Style 10, 30, V3, V9 & V30

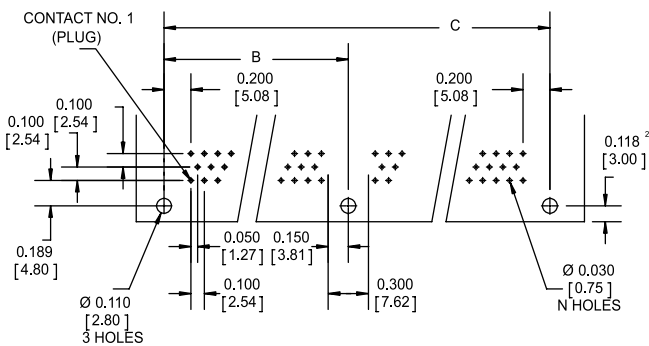

#### Daughter board application

Style 24 & V4

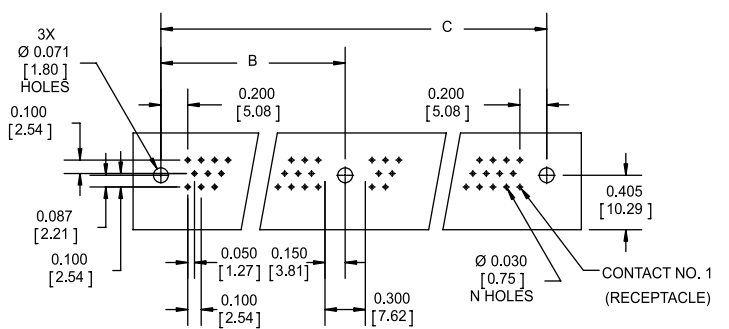

**Notes:**

- 1) For V15 locking mounting style, dimension is 0.130 ± 0.004 [3.20 ± 0.10] diameter.
- 2) PC board may be extended to 0.453 [11.50] max for use as a pin protector.

Dimensions are in inches [mm] | All content is subject to change without notice



# Panel Cutouts

## Fixed & Float Mounting Styles & Dimensions

### 2 Row Connectors

17, 29, 33, 41, 53 & 65 Contacts

Contacts	B
17	1.200 [30.48]
29	1.800 [45.72]
33	2.000 [50.8]
41	2.400 [60.96]
53	3.000 [76.20]
65	3.600 [91.44]

#### Fixed mounting

Styles 11, 21, V2, V15 & V31

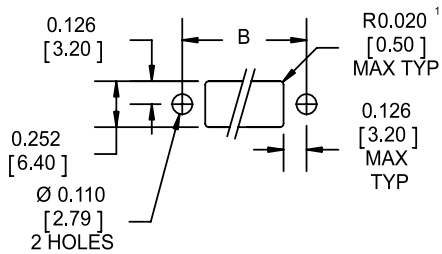

#### Float mounting

Styles 13 & 23

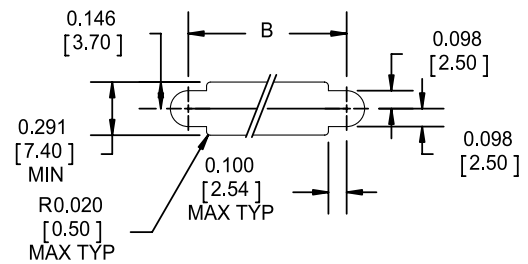

### 3 Row Connectors

62, 80.1 & 98 Contacts

Contacts	B
62	2.400 [60.96]
80.1	3.000 [76.20]
98	3.600 [91.44]

#### Fixed mounting

Styles 11, 21, V2, V15 and V31

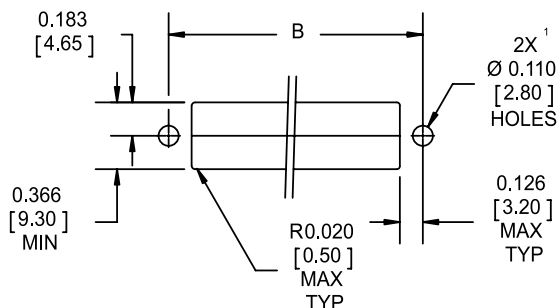

#### Float mounting

Styles 13 & 23

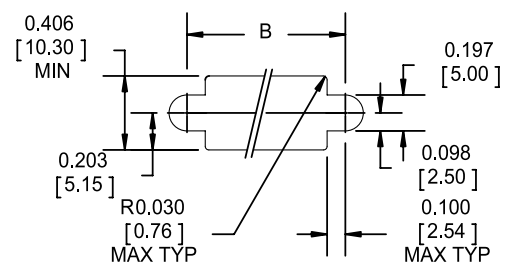

**Notes:**

1) For V15 locking mounting style, dimension is 0.130 ± 0.004 [3.20 ± 0.10] dia.

Dimensions are in inches [mm] | All content is subject to change without notice

### 3 Row Connectors

72, 84, 120 & 126 Contacts

Contacts	B	C	D <sub>MIN</sub>	E <sub>MIN</sub>
72	2.100 [53.34]	4.200 [106.68]	0.252 [6.40]	0.291 [7.50]
84	2.400 [60.96]	4.800 [121.92]	0.252 [6.40]	0.291 [7.50]
96	2.700 [68.58]	5.400 [137.16]	0.252 [6.40]	0.291 [7.50]
120	3.300 [83.82]	6.600 [167.64]	0.252 [6.40]	0.291 [7.50]
126	2.400 [60.96]	4.800 [121.92]	0.366 [9.30]	0.406 [10.30]

**Fixed mounting**  
Styles 11, 21, V2, V15 & V31

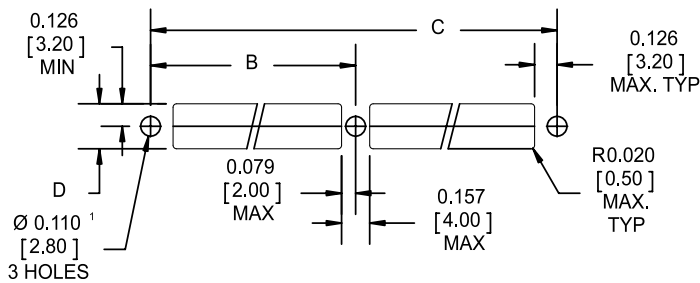

**Float mounting**  
Styles 13 & 23

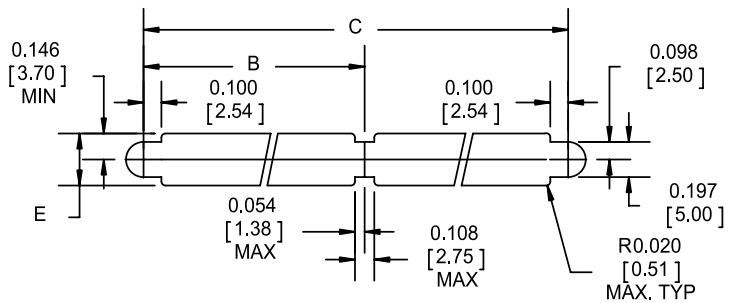

### 3 Row Connectors

160 & 160.4 Contacts

Contacts	B	C
160	2.950 [74.93]	5.900 [149.86]
160.4	2.950 [74.93]	5.900 [149.86]

**Fixed mounting**  
Styles 11, 21, V2, V15 & V31

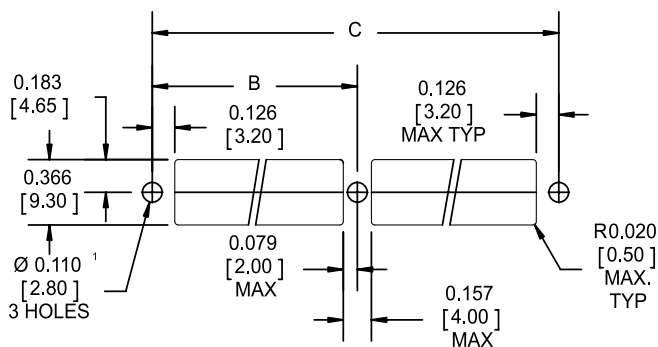

**Float mounting**  
Styles 13 & 23

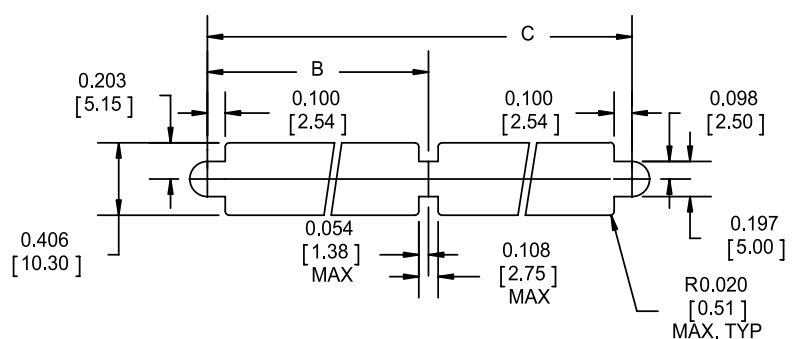

# 4 & 5 Row Connectors

48 to 490 Contacts

Center hole not required for 48 to 184 contacts

Contacts	X
48	1.500 [38.10]
68	2.000 [50.80]
80	2.300 [58.42]
96	2.700 [68.58]
100	2.800 [71.12]
108	3.000 [76.20]
120	3.300 [83.82]
125	2.800 [71.12]
128	3.500 [88.90]
136	3.700 [93.98]
140	3.100 [78.74]
160	4.300 [109.22] (4 row) 3.500 [88.92] (5 row)
184	4.900 [124.46]
196	5.200 [132.08]

Contacts	X
200	4.300 [109.22]
208	5.700 [144.78]
228	6.000 [152.40]
230	4.900 [124.46]
240	6.500 [165.10] (4 row) 5.100 [129.54] (5 row)
264	7.100 [180.34]
300	6.500 [165.10]
320	6.900 [175.26]
330	7.100 [180.34]
352	9.300 [236.22]
390	8.300 [210.82]
392	10.300 [261.62]
490	10.300 [261.62]

## Fixed mounting

Style 11, 21, V2 & V31

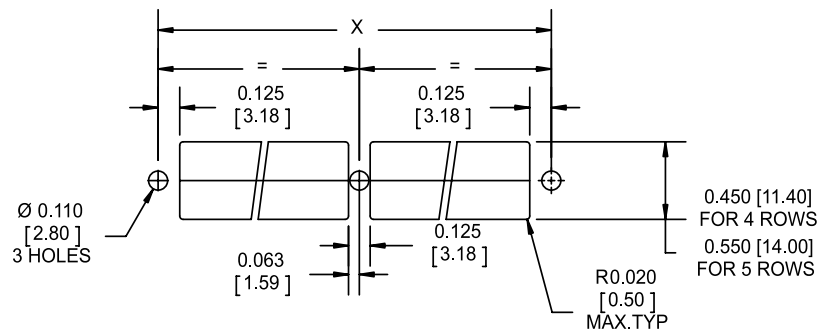

## Float mounting

Style 13 & 23

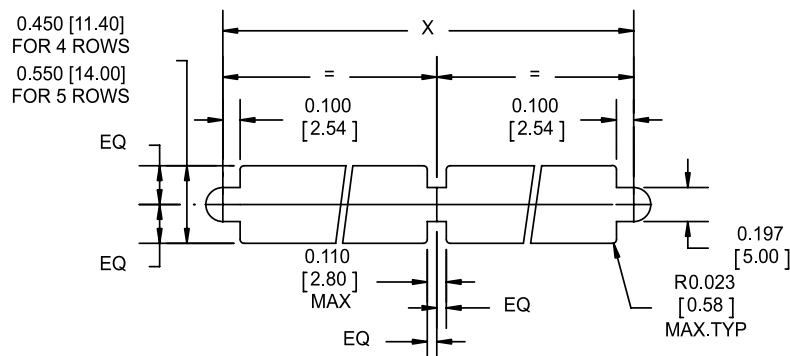

**Notes:**

1) For connectors with center guide float mounts, rows adjacent to center guide will not be loaded. Example: a KA490 will actually have 480 contacts; a KA392 will actually have 384 contacts.

Dimensions are in inches [mm] | All content is subject to change without notice

# Accessories *Insertion, Extraction, & Crimp Tooling*

## Optional tools

Insertion Tool	S/MONT 1.00600
Spanner Wrench	T136 <i>(for receptacle with front removable contacts)</i>
Extraction Tool	S/DEM 1.0060

## Crimp tools

<b>Style R &amp; H2   1 Crimp</b>	
Manual Crimp Tool	MS3198.1 or M22520/2-01 or AFM8
Positioner For Contacts	K547
<b>Style H2   2 Crimps in 2 Operations</b>	
Manual Crimp Tool	MS3198.1 or M22520/2-01 or AFM8
Positioner for Contacts (wire)	K547
Positioner for Contacts (insulation)	K640
<b>Style H2   2 Crimps in Operation<sup>(1)</sup></b>	
Crimping Instructions Document	S50063

### Notes:

1) This requires a special tool. Please submit wire samples and consult factory for further information.

Dimensions are in inches [mm] | All content is subject to change without notice

# How To Order

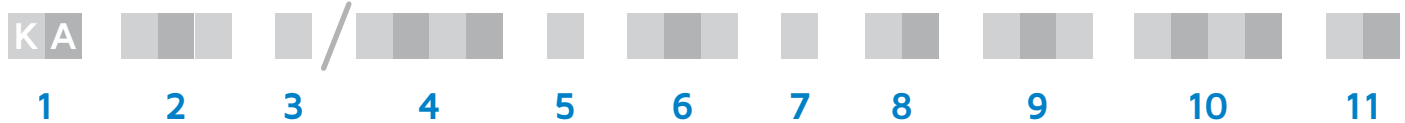

<b>1 KA Series</b>	[Fixed]																																				
<b>2 Number contacts</b> 2 & 3 Row connectors	<table border="0"> <tr> <td>17</td><td>29</td><td>33</td><td>41</td><td>53</td><td>62</td><td>65</td><td>72</td><td>80</td><td>84</td><td>96</td><td>98</td> </tr> <tr> <td>120</td><td>126</td><td>160</td><td colspan="9">Contacts</td> </tr> </table>	17	29	33	41	53	62	65	72	80	84	96	98	120	126	160	Contacts																				
17	29	33	41	53	62	65	72	80	84	96	98																										
120	126	160	Contacts																																		
4 & 5 Row connectors	<table border="0"> <tr> <td>48</td><td>68</td><td>96</td><td>120</td><td>125</td><td>128</td><td>136</td><td>140</td><td>160</td><td colspan="3"></td> </tr> <tr> <td>184</td><td>196</td><td>200</td><td>208</td><td>228</td><td>230</td><td>240</td><td>264</td><td>300</td><td colspan="3"></td> </tr> <tr> <td>320</td><td>330</td><td>352</td><td>390</td><td>392</td><td>490</td><td colspan="6">Contacts<sup>(1)</sup></td> </tr> </table>	48	68	96	120	125	128	136	140	160				184	196	200	208	228	230	240	264	300				320	330	352	390	392	490	Contacts <sup>(1)</sup>					
48	68	96	120	125	128	136	140	160																													
184	196	200	208	228	230	240	264	300																													
320	330	352	390	392	490	Contacts <sup>(1)</sup>																															
<b>3 Contact variants</b> <i>(Omit for standard versions)</i>	<table border="0"> <tr> <td>.1</td><td>For 3 row 80.1 contact version only</td> </tr> <tr> <td>.4</td><td>For 3 row 160.4 contact front removable receptacle only</td> </tr> </table>	.1	For 3 row 80.1 contact version only	.4	For 3 row 160.4 contact front removable receptacle only																																
.1	For 3 row 80.1 contact version only																																				
.4	For 3 row 160.4 contact front removable receptacle only																																				
<b>4 Number rows</b>	<table border="0"> <tr> <td>/ 1 2 7 B</td><td>2 Rows</td> <td>/ 1 2 7 C</td><td>3 Rows</td> </tr> <tr> <td>/ 2 5 4 D</td><td>4 Rows</td> <td>/ 2 5 4 E</td><td>5 Rows</td> </tr> </table>	/ 1 2 7 B	2 Rows	/ 1 2 7 C	3 Rows	/ 2 5 4 D	4 Rows	/ 2 5 4 E	5 Rows																												
/ 1 2 7 B	2 Rows	/ 1 2 7 C	3 Rows																																		
/ 2 5 4 D	4 Rows	/ 2 5 4 E	5 Rows																																		
<b>5 Insulator</b>	P Plug   E Receptacle																																				
<b>6 Locking mounting hardware</b> <i>(Omit for non-locking hardware)</i> <i>(Reference pags. 24-28 for intermatibility)</i>	<table border="0"> <tr> <td>V 1</td><td>V 2</td><td>V 3</td><td>V 4</td><td>V 6</td><td>V 7</td><td>V 9</td><td>V 15</td><td>V 30</td><td>V 31</td><td>V 32</td> </tr> <tr> <td>V 3 3</td><td colspan="10">Locking mounting styles</td> </tr> </table>	V 1	V 2	V 3	V 4	V 6	V 7	V 9	V 15	V 30	V 31	V 32	V 3 3	Locking mounting styles																							
V 1	V 2	V 3	V 4	V 6	V 7	V 9	V 15	V 30	V 31	V 32																											
V 3 3	Locking mounting styles																																				
<b>7 Contact gender</b>	M Male   F Female																																				
<b>8 Terminal styles</b>	<table border="0"> <tr> <td>B</td><td>90° 0.125 [3.18] PCB</td> <td>C</td><td>90° 0.063 [1.59] PCB</td> <td>D</td><td>Straight PCB</td> </tr> <tr> <td>F D</td><td>Front removable D contacts</td> <td>H 2</td><td>Double crimp <sup>(2)</sup></td> <td>R</td><td>Crimp</td> <td>S</td><td>Solder</td> </tr> <tr> <td>W</td><td>Wire wrap [2 wraps]</td> <td>Y</td><td>Wire wrap [3 wraps]</td> <td colspan="4"></td> </tr> </table>	B	90° 0.125 [3.18] PCB	C	90° 0.063 [1.59] PCB	D	Straight PCB	F D	Front removable D contacts	H 2	Double crimp <sup>(2)</sup>	R	Crimp	S	Solder	W	Wire wrap [2 wraps]	Y	Wire wrap [3 wraps]																		
B	90° 0.125 [3.18] PCB	C	90° 0.063 [1.59] PCB	D	Straight PCB																																
F D	Front removable D contacts	H 2	Double crimp <sup>(2)</sup>	R	Crimp	S	Solder																														
W	Wire wrap [2 wraps]	Y	Wire wrap [3 wraps]																																		
<b>9 Mounting hardware</b> No hardware Mounting styles	<table border="0"> <tr> <td>00</td><td colspan="10"></td> </tr> <tr> <td>10</td><td>11</td><td>12</td><td>13</td><td>14</td><td>21</td><td>23</td><td>24</td><td>101</td><td>111</td><td>131</td> </tr> </table>	00											10	11	12	13	14	21	23	24	101	111	131														
00																																					
10	11	12	13	14	21	23	24	101	111	131																											
<b>10 Termination plating</b>	<table border="0"> <tr> <td>T</td><td>50µin. [1.27 µm.] Gold (min) over Nickel [male only]</td> </tr> <tr> <td>TH</td><td>50µin. [1.27 µm.] Gold (min) over Nickel [male only]</td> </tr> <tr> <td>TAH</td><td>50µin. [1.27 µm.] Gold (min) over Nickel on mating surface [female only]</td> </tr> <tr> <td>TB or TBH</td><td>Tin lead option for PC style contacts [male only]</td> </tr> <tr> <td>TABH</td><td>Tin lead option for PC style contacts [female only]</td> </tr> </table>	T	50µin. [1.27 µm.] Gold (min) over Nickel [male only]	TH	50µin. [1.27 µm.] Gold (min) over Nickel [male only]	TAH	50µin. [1.27 µm.] Gold (min) over Nickel on mating surface [female only]	TB or TBH	Tin lead option for PC style contacts [male only]	TABH	Tin lead option for PC style contacts [female only]																										
T	50µin. [1.27 µm.] Gold (min) over Nickel [male only]																																				
TH	50µin. [1.27 µm.] Gold (min) over Nickel [male only]																																				
TAH	50µin. [1.27 µm.] Gold (min) over Nickel on mating surface [female only]																																				
TB or TBH	Tin lead option for PC style contacts [male only]																																				
TABH	Tin lead option for PC style contacts [female only]																																				
<b>11 Keying orientation</b>	A 1 [Omit for default keying positions C & 3]																																				

**Notes:**  
 1) Special sizes from 48 to 392 (4 row) and from 60 to 490 (5 row) are available. Please consult factory.  
 2) Crimp contacts will be shipped unloaded. When inserting contacts into the insulator, be sure the two flats at the rear of the contact body are aligned with the flats in the insulator.

# Military Part Number Cross Reference

## Smiths Interconnect's Part Number Cross Reference

Slash sheets 159 and 160

Receptacle 2 Row Insulator Styles  
For 17 to 120 Contact Positions

MIL-DTL-55302 / 159 E 17 B

KA 17 / 127 BE F C 21 TAH

C	E	R	K	A	D	S	L	Y	M	H	B	F
M	F	M	F	M	F	M	F	F	M	F	M	F
C	C	R	R	D	D	S	S	Y	H2	H2	B	B
H	AH	H	AH	H	AH	H	AH	AH	H	AH	H	AH

17	29	41	53	65	72	84	96	120
159				160				

V	W	B	P	T	U	J	X	Z	G	F
24	14	21	11	23	13	V1	V15	V7	V2	V4

Slash sheets 162 and 163

Receptacle 2 Row Insulator Styles  
For 17 to 120 Contact Positions

MIL-DTL-55302 / 162 C 17 W

KA 17 / 127 BP M C 10 TH

C	E	R	K	A	D	S	L	Y	M	H	B	F
M	F	M	F	M	F	M	F	F	M	F	M	F
C	C	R	R	D	D	S	S	Y	H2	H2	B	B
H	AH	H	AH	H	AH	H	AH	AH	H	AH	H	AH

17	29	41	53	65	72	84	96	120
162				163				

V	W	B	P	T	U	J	K	X	Y	Z	G	F
24	14	21	11	23	13	V1	V3	V15	V8	V7	V2	V4

# Military Part Number Cross Reference

## Smiths Interconnect's Part Number Cross Reference

### Slash sheet 161

160 Position Split Shell Receptacles

D55302/161 J 160 G	KA 160.4/127CEFD21TAH
D55302/161 G 160 G	KA 160.4/127CEFY21TAH
D55302/161 P 160 G	KA 160.4/127CEMD21TAH
D55302/161 Q 160 G	KA 160.4/127CEMY21TAH

### Slash sheet 164

160 Contact Position Plugs and Receptacles

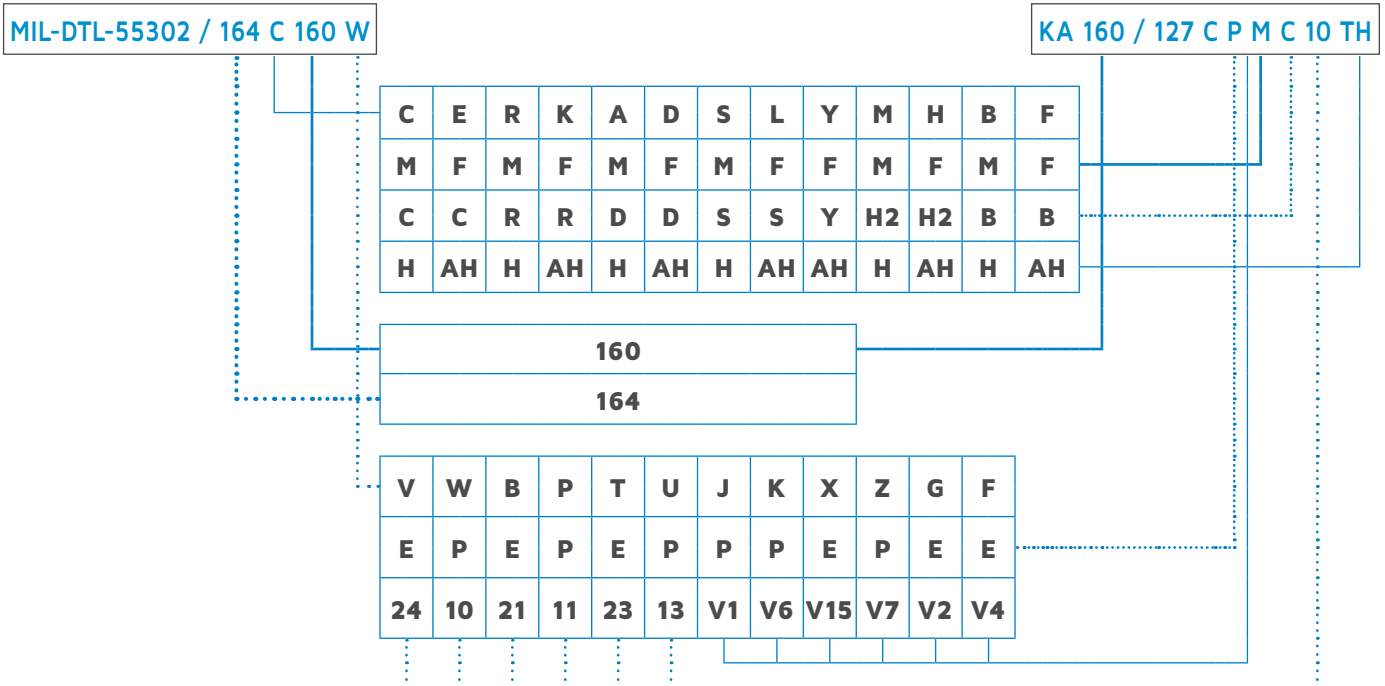

## Disclaimer 2020

All of the information included in this catalog is believed to be accurate at the time of printing. It is recommended, however, that users should independently evaluate the suitability of each product for their intended application and be sure that each product is properly installed, used and maintained to achieve desired results.

Smiths Interconnect makes no warranties as to the accuracy or completeness of the information, and disclaims any liability regarding its use.

Smiths Interconnect reserves the right to modify design and specifications, in order to improve quality, keep pace with technological development, or meet specific production requirements.

Reproduction or use of editorial and/or pictorial content in any manner, without express written permission, is prohibited.

# Product Portfolio

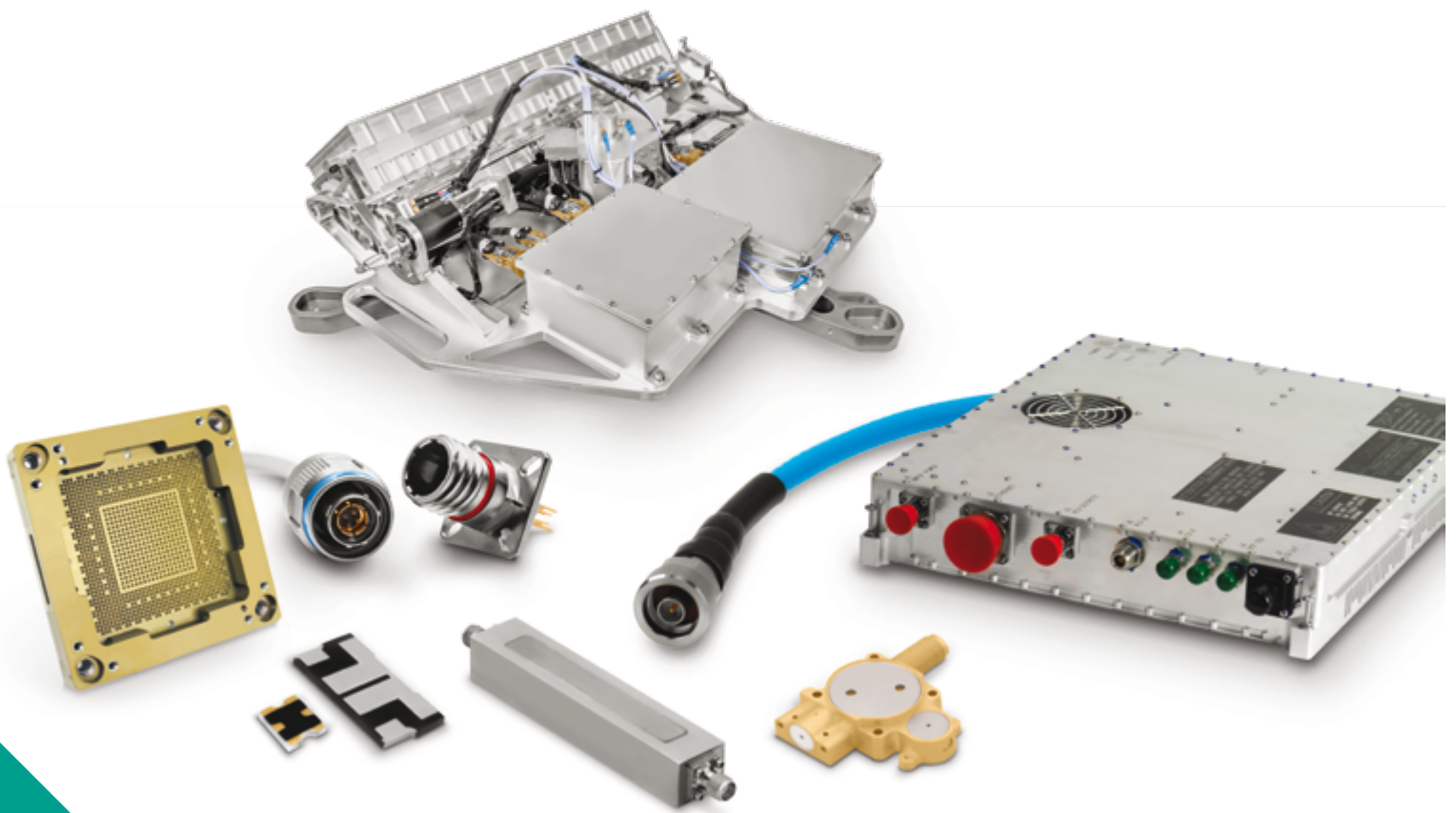

- Antenna Systems
- Cable Assemblies
- Connector Solutions
- Ferrite Components & Assemblies
- RF Filter Components & Assemblies
- Integrated Microwave Assemblies
- Millimeter-Wave Solutions
- RF Components
- Test Sockets and WLCSP Probe Heads
- Time & Frequency Systems

# Global Support

## Americas

- Kansas City, KS  
+1 913 342 5544  
info.us@smithsinterconnect.com
- Tampa, FL  
+ 1 813 901 7200  
info.tampa@smithsinterconnectinc.com
- Milpitas, CA  
+1 408 957 9607 x-1125  
info.us@smithsinterconnect.com
- Kirkland, QC, Canada  
+1 514 842 5179  
info.us@smithsinterconnect.com
- Salisbury, MD  
+1 800 780 2169  
info.us@smithsinterconnect.com

## Europe

- Deggendorf, Germany  
+49 991 250 120  
info.de@smithsinterconnect.com
- Rouen, France  
+33 2 3296 9176  
info.fr@smithsinterconnect.com
- Dundee, UK  
+44 1382 427 200  
info.dundee@smithsinterconnect.com
- Genova, Italy  
+39 0 10 60361  
info.it@smithsinterconnect.com

## Asia

- Bangalore, India  
+91 080 4241 0529  
info.in@smithsinterconnect.com
- Singapore  
+65 6846 1655  
info.asia@smithsinterconnect.com
- Mianyang, China  
+86 816 231 5566  
HSICSR@hf-smiths.com
- Suzhou, China  
+86 512 6273 1188  
info.asia@smithsinterconnect.com
- Shanghai, China  
+86 21 2283 8008  
info.asia@smithsinterconnect.com

more > [smithsinterconnect.com](https://www.smithsinterconnect.com) | [in](#) [twitter](#) [youtube](#)