



Sensata
Technologies

**SENSOR
SOLUTIONS FOR
PRODUCTIVITY
APPLICATIONS**



**Our solutions help
make products safer,
cleaner and smarter,
more productive and
connected**

For more than 100 years, we have provided a wide range of customized, sensor-rich solutions that address complex engineering requirements to help customers solve difficult challenges in many industries. Our solutions help to make products safer, smarter, more productive and connected.

Table of Contents

Why Sensata

Solutions Overview

Productivity Applications

Process Automation

Manufacturing

Pneumatics & Hydraulics
Air Compressors
Plastic Machinery
Printing Machines

Chemical & Petrochemical

Oil & Gas

Metal & Mining

Metal Production

Food & Beverage

Processing Lines

Factory Automation

Material Handling

Elevated Work Platforms
Forklifts & Reachtrucks
Automated Guided Vehicles
Special Equipment (Forestry, Mining, Groundworks)

Assembling

Robotics
Assembly Lines

Packaging

Packaging Lines
Conveyor Belts

We help you develop smart, productive and safe motion enabled solutions

In a connected environment, machinery and equipment are able to improve processes through automation and self-optimization.

We are a global industrial technology leader and an early innovator in mission-critical sensors and controls, helping our customers to develop powerful, small, precise and safe motion enabled solutions.

Our innovations are ushering in IoT adoption and position our customers for success. Together with you, we enable a cleaner, safer, smarter and more productive manufacturing environment.

Car Plants and other sites with Conveying Machinery

Monitoring of key production motors and ancillary equipment

Container Trucks

In transit logging and display of temperature

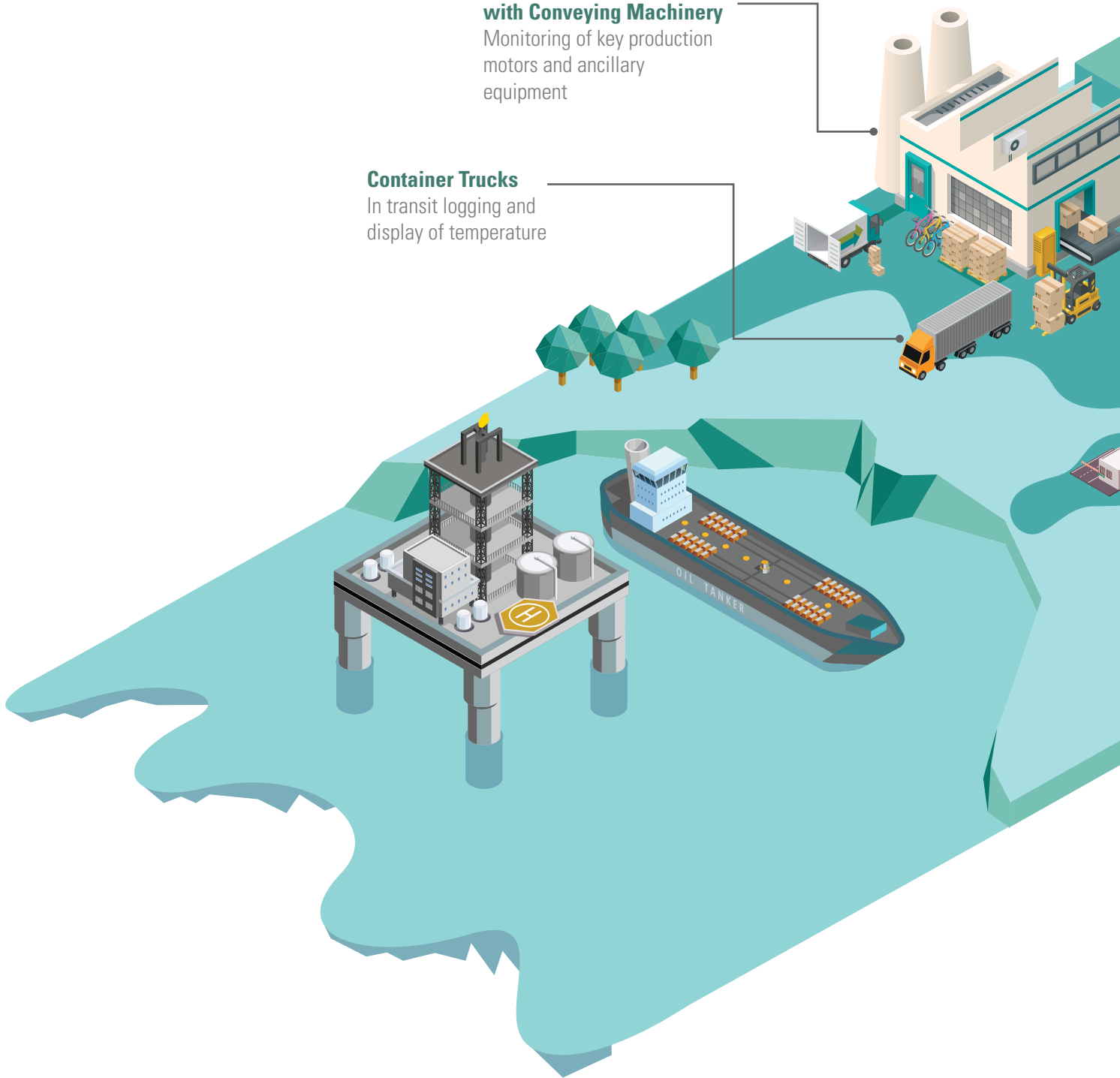

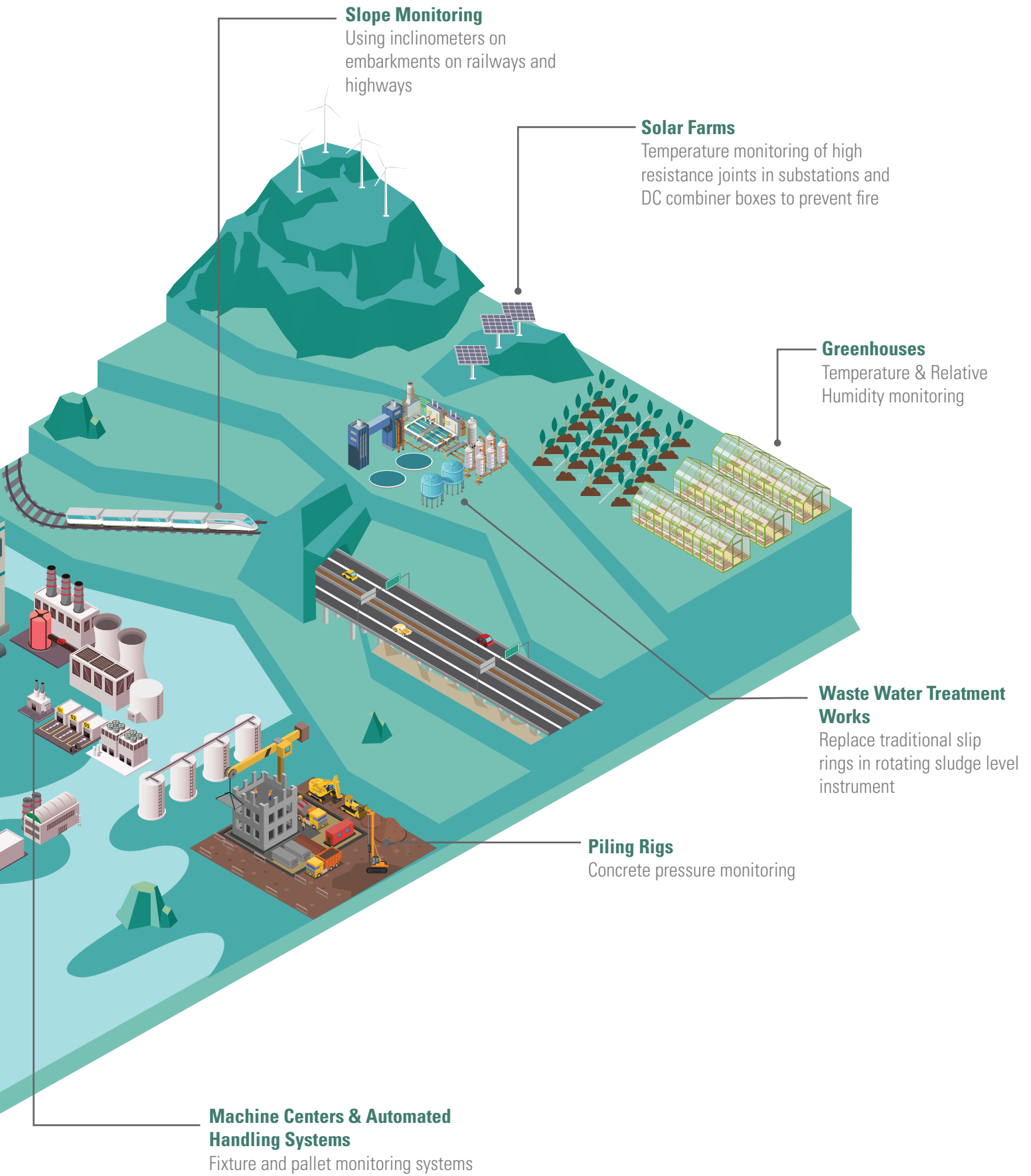

Why Sensata

We have a deep knowledge and understanding of a broad range of industrial applications and we offer advice and support to help you select the right product for your application. All our products are of exceptional quality. We take pride in the flexibility we drive in our operations to customize products at a global scale.

Solution capability: installation, training, support, consumables, local presence

-  Industry-specific knowledge and proprietary technology in mission critical and hard-to-do applications
-  Solution capability, partnership mindset of our team, and flexible technology for customized solutions
-  Cost-convenient manufacturing model with concentrated manufacturing operations across the globe
-  Strong teamwork to deliver fast responses to our customers, with deep understanding of product design cycles and launch execution

What Our Customers Say

European OEM for Transportation Equipment Manufacturing, France:

"We use encoders in our equipment and we started to have problems with them during extreme weather conditions, as the housing was expanding and contracting.

We tested some encoders from Sensata Technologies and our team was impressed by the custom design made in a very short time. We worked very closely with their engineering team and they have a deep knowledge of their products and a great understanding of our application. Also the lead time was very fast."

Fast Facts

2021 Net Revenues: \$3.8B

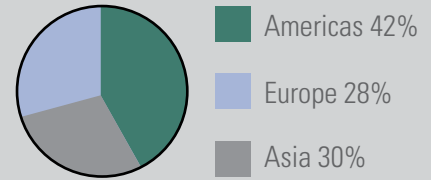

47,000+
different products
manufactured

1.1B
devices shipped each year,
each highly engineered

21,000+
employees worldwide

13
countries with business centers
and manufacturing sites

Solution Overview

Application		Pressure Sensors and Switches	Temperature Sensors and Thermal Cut-Outs	Position Sensors and Encoders	Motor Protectors	Solid State Relays	Float and Level Switches	Operator Controls
Manufacturing	Pneumatics & Hydraulics	•		•				
	Industrial Air Compressors	•	•		•			
	Plastic Machinery	•	•	•	•	•		
	Printing Machines			•		•	•	
Chemicals & Petrochemicals	Oil & Gas Platforms	•		•			•	
Metal & Mining	Metal Production	•	•	•		•		
Food & Beverage	Food Processing Lines	•		•		•	•	
	Fluid Management	•		•			•	
Material Handling	Forklifts & Reachtrucks	•		•		•		•
	Mobile Elevated Work Platforms	•		•		•		•
	Automated Guided Vehicles	•		•		•		•
	Woodworking Machines	•		•		•		•
	Mobile Boom Cranes	•		•		•		•
Assembling	Assembly Equipment, Robotics and Cobotics	•		•				
	Conveyor Belts			•		•		
Packaging	Packaging, Sorting, Palletizing			•		•		

Functional Solutions

Pressure Sensors

Broad portfolio of pressure products based on a variety of proven technologies. From pressure sensors that offer ranges from 1 inch H2O to 10,000psi or vacuum up to 600bar, to our highly reliable pressure switches with a wide range from 0 – 2000 psi or 0 – 140 bar, our pressure solutions provide the configurability and performance needed for demanding industrial applications.

Temperature Sensors

Our comprehensive range of thermal solutions can meet many electrical protection needs. Our portfolio is easily configurable and includes rugged industrial thermostat switches and temperature sensors, with a wide range of form factors and connection options. Sensata is a global leader in high temperature exhaust gas sensing with solutions approaching 850°C.

Position Sensors and Encoders

Our comprehensive Encoders and Position Sensors line includes incremental and absolute encoders, hall effect sensors, rotary and linear potentiometers as well as inclinometers and draw wire solutions. Reliable and rugged products that are designed for use in standard industrial to heavy duty and hazardous area applications.

Solid State Relays

Sensata's Crydom brand is a market leader with the widest range of off-the-shelf solid state relays and contactors, as well as custom-designed solid state switching solutions for professional ovens, vending machines, deep fat fryers, coffee machines and more.





Pneumatics and Hydraulics

Pressure sensors maintain a constant output pressure of the gas or liquid, in order to avoid any leaks that could cause dangerous accidents.

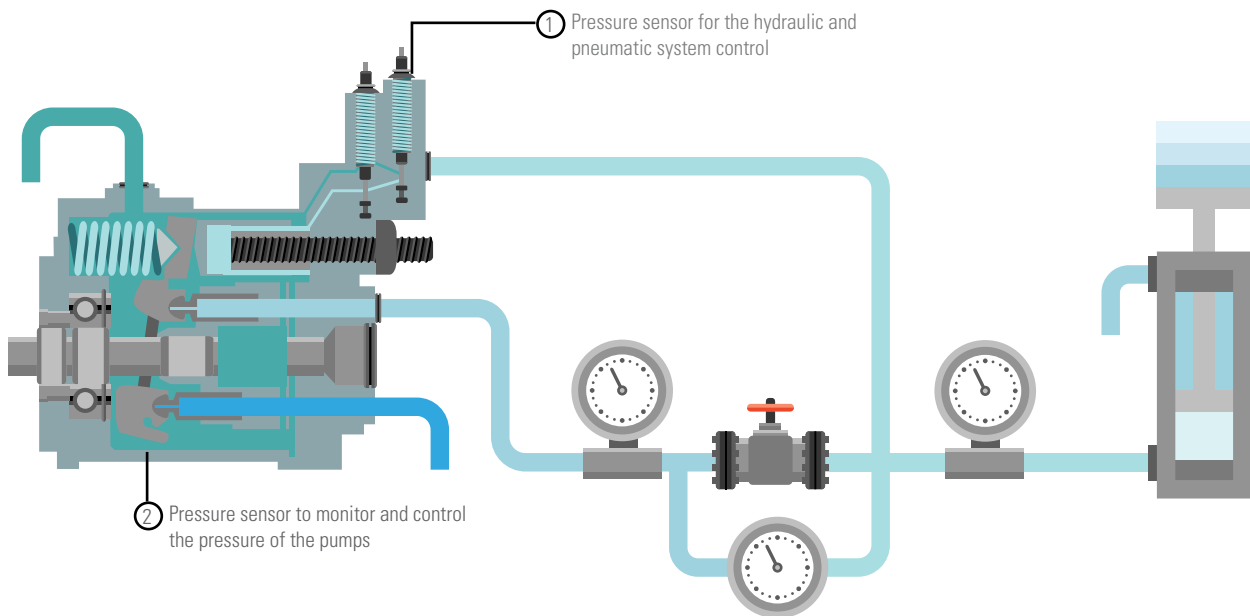
Pneumatic technology is used in vehicle tires, air brakes of buses, trucks or trains, compressed-air engines, vacuum pumps and more. Hydraulic systems are used in vehicle braking systems, power steering systems, shock absorbers, material handling vehicles such as excavators and aerial work platforms, and more. Making sure the right gas or liquid pressure is administered to these systems is crucial, especially when we speak about hydraulics, where the liquid in the system may be flammable. If the pressure or the temperature range are not correct, this can cause dangerous leaks and accidents.

Pressure sensors are used for pressure regulators, which match the demand for gas or liquid to the demands of the system, while maintaining a constant output pressure. Float switches make sure to keep the liquid level at an optimum level.



	2CP5 Pressure Sensors	<ul style="list-style-type: none"> • UL recognized ceramic capacitive sensor, overvoltage and short circuit protected • Durable, compact, low-cost design, with accurate performance over wide temperatures 	It measures the air pressure in the pneumatic system
	PTE7100/PTE7300 Hermetic Analog Pressure Sensors	<ul style="list-style-type: none"> • Ideal for mid and high pressure ranges • Microfused Strain Gauge (MSG) with best-in-class accuracy • Wide range of ports, connectors, and analog electrical outputs for ease of integration in various industrial applications 	Hydraulic and pneumatic system control
	9960 Series	<ul style="list-style-type: none"> • Small package and easy integration; versatile due to the 360 degree turn capability • Packaged in a highly sealed (IP69K) housing and utilizing non-contacting Hall effect technology 	Permit to monitor and control the pressure of the pumps
	ACW4/TCW4 Series	<ul style="list-style-type: none"> • Two-part design, modular, offering maximum flexibility during installation; IO-Link with COM3 transmission rate • Easy commissioning and configuration with IO-Link; Simple device replacement with data storage capability 	Permit to monitor and control the pressure of the pumps
	IMP Industrial Pressure Transmitters	<ul style="list-style-type: none"> • Excellent media compatibility, very stable electronics especially in high vibration and shock applications • Every device is temperature compensated and calibrated and supplied with a traceable serial number and calibration certificate 	Monitor the air pressure supply to power pneumatic controls. Very stable in high vibration and shock applications.





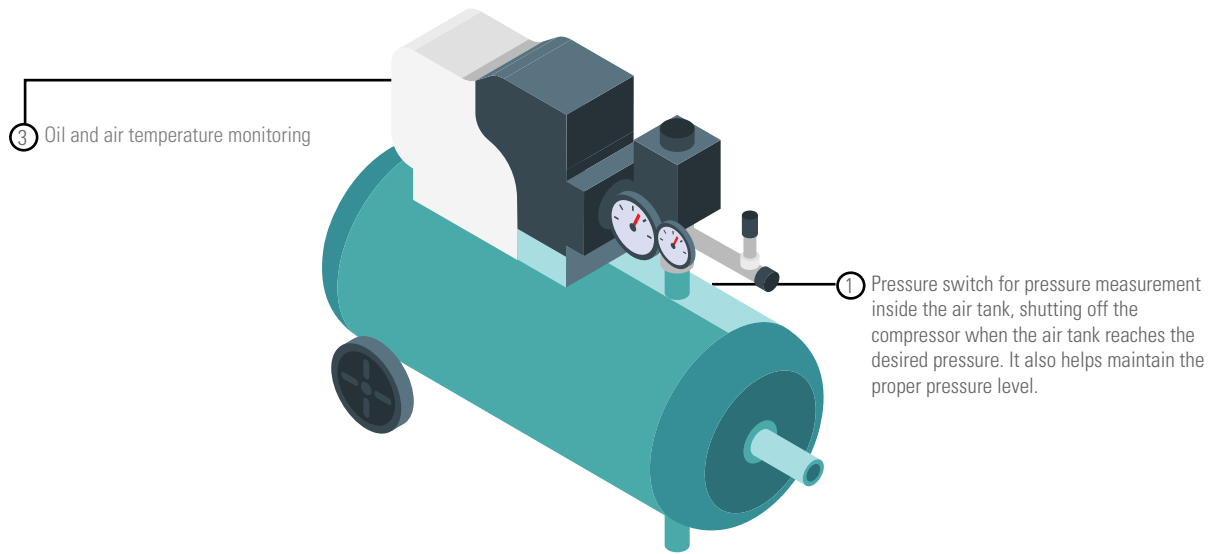

Industrial Air Compressors

Heavy-duty industrial air compressors operate at high pressure levels, therefore they rely on high horsepower motors and heavy-duty components. Typical industrial air compressor uses include spraying crops and ventilating silos in agricultural facilities, running pneumatic machinery in manufacturing plants, operating laundry presses in dry cleaners and various processes in food and beverage manufacturing, oil and gas operations and more.

Pressure switches and sensors are key parts of the air compressors, and they need to be very robust, reliable and completely safe in operation. They control the operation and their main function is to start the air compressor when the pressure in its holding tank drops below a set low point and to stop it when the pressure reaches a set maximum. Maintaining a constant working charge in the system is an essential condition for operations hard stop.

The PTE7100 hermetic analog pressure sensor from Sensata has extreme shock and vibration capabilities and high proof and burst pressures, which makes it ideal for use in any kind of industrial air compressors.



①	 PS80 Automatic Reset Pressure Switches	<ul style="list-style-type: none"> Safe and reliable automatic reset pressure switch, offering a wide range of pressure settings, port fittings and electrical connections Its robust non-electric construction safely operates under high pressure conditions helping keep maintenance costs and return rates low 	Measures the pressure inside the air tank and shuts off the compressor when the air tank reaches the desired pressure. It also helps to maintain the proper pressure level.
②	 PTE 7100 Series	<ul style="list-style-type: none"> Microfused Strain Gauge (MSG) with best-in-class accuracy Wide range of ports, connectors, and analog electrical outputs for ease of integration in various industrial applications 	Oil pressure measurement Monitoring of the air inlet and outlet pressure
③	 3000 Series	<ul style="list-style-type: none"> It offers the choice of thermistor or RTD temperature sensing technology Since no single technology is optimal for every application, the 3000 series offers several thermal sensing options, each of which offers unique advantages. 	Oil and air temperature monitoring
④	 112CP Series	<ul style="list-style-type: none"> Pressure and temperature measurement in one package Fast, in-stream temperature measurement and precise superheat measurement 	Pressure and temperature measurement of the compressed air
⑤	 8EA Solid State Contactors	<ul style="list-style-type: none"> Solid-state PTC motor starter, available for all single phase voltage applications, low power dissipation, easy installation Electrically (EMI) noise free, operating noise free, approved for use with explosive proof applications, high reliability with no moving parts 	Designed for use with most split phase, capacitor run and/or start, fractional h.p. hermetic compressors
⑥	 15HM Series Motor Protectors	<ul style="list-style-type: none"> Compact and rugged design, resistant to mechanical shock and suitable for installation directly on motor windings Meet rotary compressor high side pressure requirements, application range 1 to 5 HP 	Protection from overheating of the compressor motor. They may also be used in commercial motors which must function in destructive or corrosive environments.

Plastic Machinery





Solid state relays are preferred over their electromechanical counterparts because of their extended lifetime, resistance to shock and vibration, and fast switching.

Injection molding is a very common process used for producing plastic, glass or metal parts. This process consists of passing the desired material through a heating and mixing process and injecting it into a mold. Injection molding is used for producing a great variety of plastic parts such as bottles, cases or automotive parts.

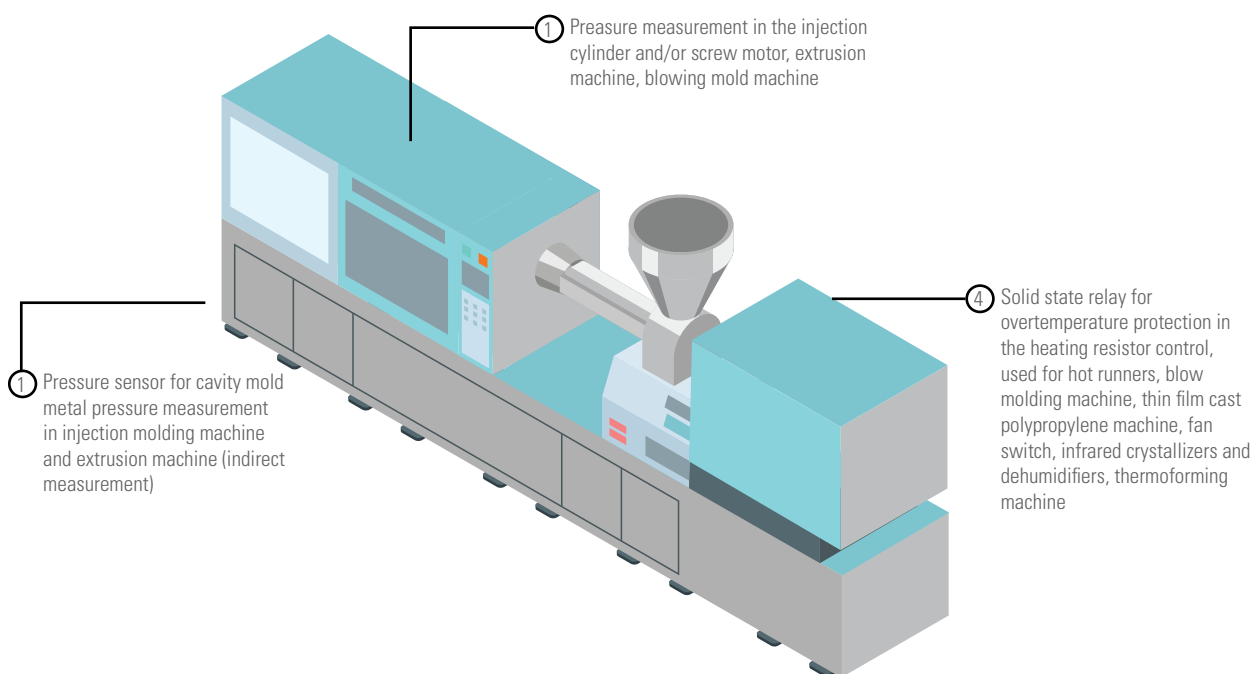
Solid state relays are ideal for use in plastic injection molding machines. They are preferred over their electromechanical counterparts because of their extended lifetime, resistance to shock and vibration, and fast switching.

Solid state relays can be used to switch the barrel and mold heaters, allowing for precise temperature control, thanks to their ability to switch fast and often. A single SSR can drive several heater zones. SSRs can also adjust the position of the tool and get the mold accurately clamped. A solid state reversing contactor provides the required accuracy in addition to a higher life expectancy than an electromechanical contactor. They can also actuate the pins that eject the molded part. A compact DIN Rail mount SSR saves cabinet space and provides extended reliability.



	<p>PTE 7100, 7300 Series</p> <ul style="list-style-type: none"> • Ideal for machines in the mid and high pressure ranges • Wide range of ports, connectors, and analog electrical outputs for ease of integration in various industrial applications 	<p>Pressure measurement in the injection cylinder and/or screw motor, extrusion machine, blowing mold machine</p>
	<p>DR45 Solid State Relays</p> <ul style="list-style-type: none"> • 60 Amp rated solid state relay, cage clamp terminals accept up to 3 AWG wire size, built-in overvoltage protection • High voltage, load monitoring module available, integrated fan for better performance, alarm output 	<p>Overtemperature protection in the heating resistor control, used for hot runners, blow molding machine, thin film cast polypropylene machine, fan switch, infrared crystallizers and dehumidifiers, thermoforming machine</p>
	<p>SOLICON DRC Solid State Contactors</p> <ul style="list-style-type: none"> • 7.6 Amp solid state reversing contactor, built-in overvoltage protection, ultra-efficient thermal design 	<p>Overvoltage protection of the clamping unit</p>
	<p>Series ONE DR Solid State Relays</p> <ul style="list-style-type: none"> • Ready-to-use solid state relay, compact size (11 or 18mm), HP rated 	<p>Overvoltage protection in the ejection system</p>





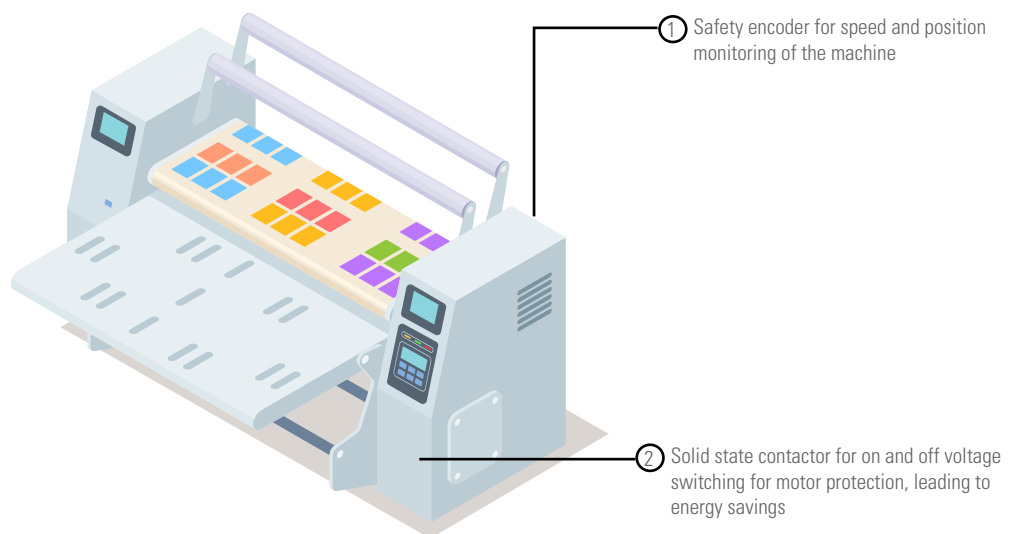

Functional Safety in Printing Machines

Large, high speed printers (like those for newspapers) can be very dangerous. Typically, if there is a violation of the safe space around the equipment it calls for an immediate shutdown. The primary function, safety for the workers is preserved, but there is a commercial cost in terms of significant loss of product, perhaps damage to the web control, and the need to reset the machine.

In an alternative process, a high speed printer operation can be viewed as having different safety zones, each controlled by its own motor in synchronization with the other motors. By treating each section in this way, a safety violation in one area allows that area to respond quickly, maybe executing a knife cut and dumping excess paper very quickly while the other sections adjust their speed in such a way to protect their functions but also ramp down the speed in a safe manner. This maintains the safety aspects, while also reducing the commercial cost of a safety violation.

A safety violation in one area allows that area to respond quickly, maybe executing a knife cut and dumping excess paper very quickly.



	<p>DSU9H Hollow Shaft Safety Encoder</p> <ul style="list-style-type: none"> • Usable up to SIL3/PLe, suitable for safe motor feedback, especially designed for heavy-duty applications • Compact and robust, excellent resistance to shock and vibration, stainless steel version available 	<p>Ideal for long paper length measurement Synchronization of the rolling mill rotors Encoder is also defining the speed of the ink projection</p>
	<p>DRA3 Solid State Contactor</p> <ul style="list-style-type: none"> • Built-in overvoltage protection, LED input status indicator • Wide range of AC and DC control voltage options, cage style screw terminals for easy installation 	<p>Voltage on and off switching for motor protection, leading to energy savings</p>
	<p>CX Solid State Relays</p> <ul style="list-style-type: none"> • PCB Mount, AC output, industry standard SIP package style • SCR output with 5 Amps @ 280 VAC ratings and a high surge current capability in a small package • Available with an AC input and Zero Voltage Turn-On output 	<p>Voltage on and off switching for motor protection, leading to energy savings</p>
	<p>Series 1 Solid State Relays</p> <ul style="list-style-type: none"> • SCR output for heavy industrial loads, AC or DC control • Zero voltage (resistive loads) or random-fire (inductive loads) output; LED input status indicator optional 	<p>Voltage on and off switching for motor protection, leading to energy savings</p>
	<p>DHM5 Programmable Incremental Encoders</p> <ul style="list-style-type: none"> • Easy programming without any specific software or hard-ware • Robustness and excellent resistance to shocks / vibrations • High protection level IP65, IP67 option with a sealing flange • High resolutions available, universal electronic circuits from 5 to 30 Vdc, high performances in temperature -30°C to +70°C 	<p>Ideal for long paper length measurement Synchronization of the rolling mill rotors Encoder is also defining the speed of the ink projection</p>
	<p>Vertical Plastic Float Switch with Internal Mount</p> <ul style="list-style-type: none"> • Compact Design. Available in PPS, Polypropylene, Nylon and PVDF • User configurable N/O or N/C operation; E11M12 or 1/8NPT mounting thread 	<p>Detects the high and low levels of solvent and inks in tanks</p>

Oil and Gas Platforms

Sensata is among the few companies in the industry that has tested its motors to 30K PSI under maximum temperature extremes exceeding 200°C.

The oil and gas exploration and drilling process has become more complex as it reaches deeper than ever before. An increase in the number of directional or “geosteering” operations has driven the need for improved Measurement-While-Drilling (or MWD) logging equipment, which is used to provide real-time positional data to assist with the proper orientation and steering of the drill.

Knowing the location of the drill tip is vital to proper operation of the rig. In addition, it helps in planning when to change out drill bits, when to take certain measurements, how much windup to expect, how to weight the drill string and so on. It is not uncommon to have rotary encoders stacked up on the rotational axis of the DrawWorks, both for redundancy and for sharing signals with other operations on the rig. The ideal encoder would be explosion proof (required by the proximity to explosive gases), stackable (for redundancy and communication) and be able to communicate over long distances reliably. The MAAX encoder from Sensata is all of these things: engineered with this specific application in mind it is a complete solution to the issues of operating a DrawWorks on a drilling rig.

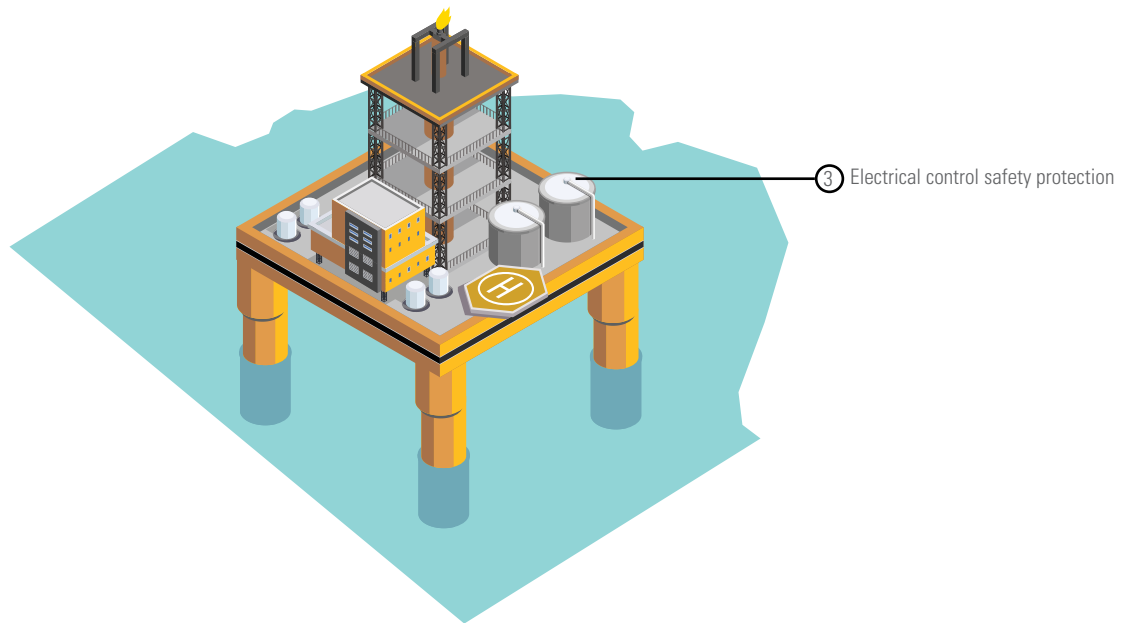

①



**HS35
Intrinsically
Safe Encoders**

- Rated for class 1 Div 1, compact size, ruggedized against shock and vibration

Measurement of the wire rope as well as signal sharing with other operations on the rig

②



**Electronic
I/O Module**

- This module option provides a method to divide the effective resolution and signal frequency of a quadrature output incremental encoder

Electrical control safety protection

③



**MAAX Absolute
Explosion Proof
Encoders**

- Stackable and explosion proof design, the first of its kind, which makes for a simple installation wherever encoders are mounted in tandem to provide multiple signals for redundancy or when data sharing is desired
- The Profibus interface simplifies system set up as it allows for daisy chaining products together without the need for running a control cable from the panel to each individual component

Position sensing solution for oil and gas applications such as DrawWorks, top drives and pipe handling equipment where working conditions are extreme.





Metal Production

Requirements for motion control in iron and steel production machinery are challenging, as the machines need to work under highest precision, reliability and productivity conditions, even in harsh environments with high temperature. The safety factor is also critical.

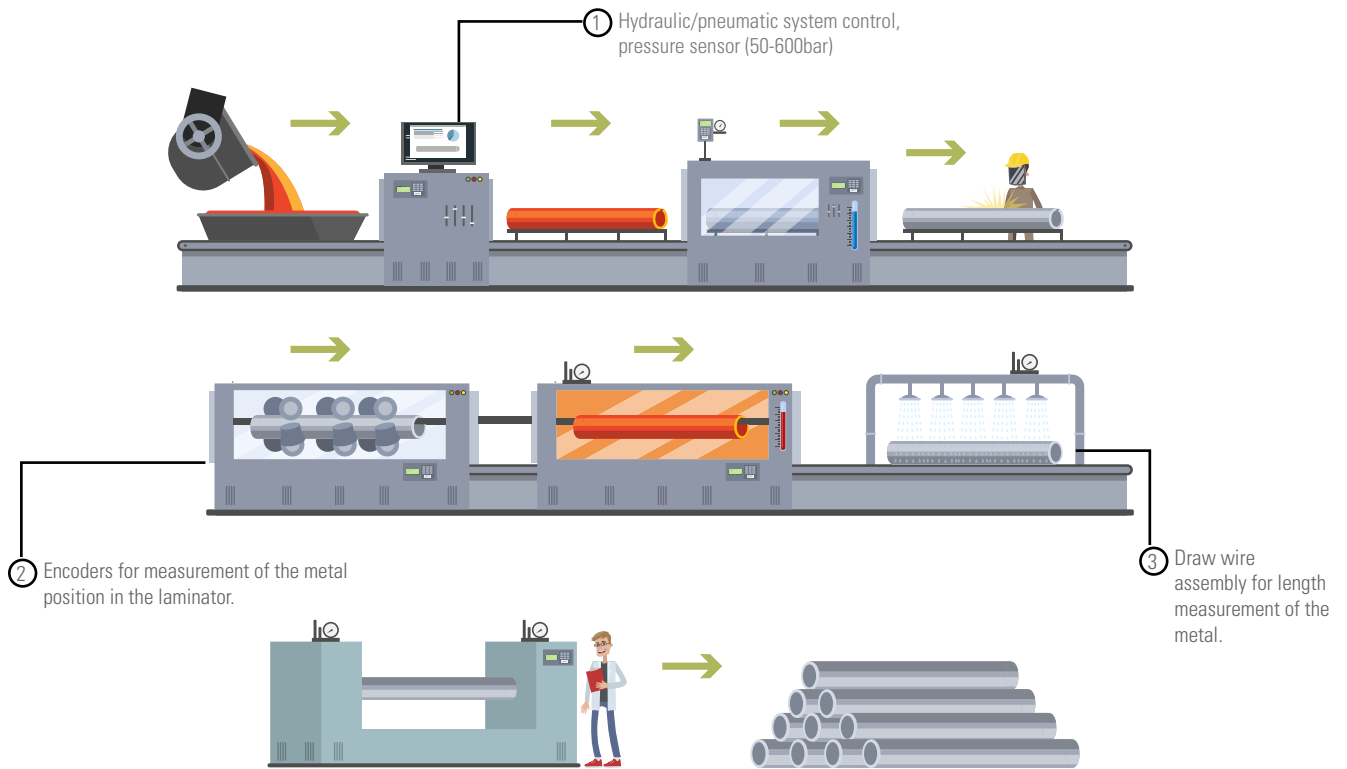
Sensata has a broad range of high quality and robust sensor solutions for the hydraulic and electric parts of the most demanding iron and steel production machinery. More importantly, our team will partner with you right from the design level, and will be there for you whenever needed.

Our engineers have a deep application knowledge which enables us to offer you customized products as well as unique support along the product lifecycle.



①		<p>PTE7100 Hermetic Analogue Pressure Sensor</p> <ul style="list-style-type: none"> • Ideal for machines in the mid and high pressure ranges • Wide range of ports, connectors, and analog electrical outputs for ease of integration in various industrial applications 	Hydraulic/pneumatic system control
②		<p>CHU9 Absolute Single Turn Encoders</p> <ul style="list-style-type: none"> • Especially designed for heavy duty industry, excellent resistance to shocks and vibrations and to extreme axial and radial loads 	Measurement of the metal position in the laminator
③		<p>CD120 Series</p> <ul style="list-style-type: none"> • Consists of a wire drum combined with a rotary sensor, commonly an encoder or a potentiometer • The wire drum is mounted to the sensor so that as wire is extended or retracted it causes the sensor to rotate. 	Length measurement
④		<p>DSUH9 SIL3 Incremental Rotary Encoder</p> <ul style="list-style-type: none"> • Especially designed for heavy-duty applications, compact and robust design; excellent resistance to shock and vibration, usable up to SIL3 /PLc 	Measurement of the metal element length, when there is an interaction between man and machine
⑤		<p>TC Thermocouple Isolator</p> <ul style="list-style-type: none"> • Provides an isolated thermocouple mV signal output from a non-isolated thermocouple • Ultra compact DIN rail mount enclosure; prevents earth loop & sensor failure problems in multi-thermocouple installations 	Isolates thermocouple signals to allow noise-free reading of furnace temperatures





Food Processing Lines

Using functional safety components, it is possible to operate the equipment in a slow, but safe pace during the cleaning operation. The improved uptime and availability of equipment more than pays for the upgrade to a functional safety system.

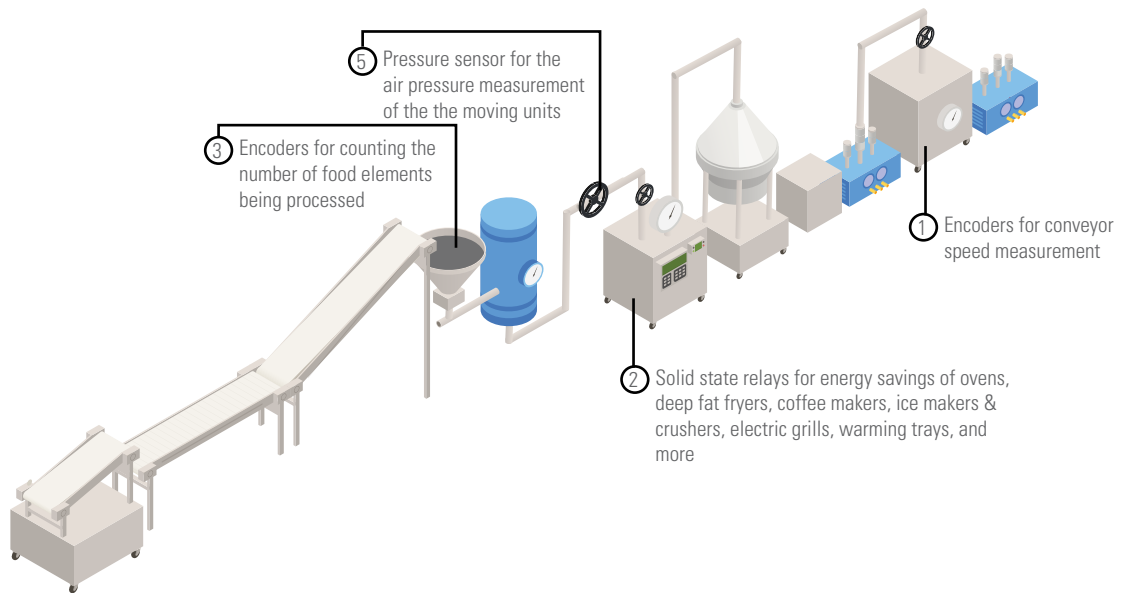
It has always been a time consuming effort to clean up food processing equipment before switching to different products. In fact the process can sometimes take a whole shift. Part of the reason is that the equipment cannot be run at full operating speed during clean-up due to the safety hazard of having people work so near to equipment. This means that the normal process is to clean the accessible part of the machinery, step back, jog the equipment forward and then clean up the newly exposed surfaces. This process is repeated until all areas of the equipment have been cleaned. The equipment is then ready to be put back into service.

Using functional safety components, it is possible to operate the equipment in a slow, but safe pace during the cleaning operation. Some of the control functions that are available within the functional safety system include Safely-Limited Speed (SLS) and Safe Direction (SDI). Referring to our example application in the food industry, under Functional safety it is possible to have the equipment running continuously and slowly in a controlled fashion using these limitations. This allows workers to continuously clean the equipment as it moves, thereby ensuring they can access all parts of the equipment easily and efficiently. Where such systems have been used, the changeover time has been reduced to as little as two hours.



 <p>DSM5X SIL3 Stainless Steel IP69K Incremental Rotary Encoder</p>	<ul style="list-style-type: none"> • Usable up to SIL3/PLc; suitable for safe motor feedback, stainless steel material • Robust and excellent resistance to shocks and vibrations 	<p>Conveyor speed measurement</p>
 <p>CW, EL Solid State Relays</p>	<ul style="list-style-type: none"> • Panel mount AC output solid state relay offering a back-to-back SCR output for reliable switching of commercial and heavy industrial loads • Output ratings of 10 Amps at 24 to 280 VAC, it comes with Zero Voltage Turn-On (for resistive loads) output, includes a removable IP20 "touch-safe" cover for added safety and LED status indicator 	<p>Energy saving of professional food equipment such as ovens, deep fat fryers, coffee makers, ice makers & crushers, electric grills, warming trays, and more</p>
 <p>AXM5S Series</p>	<ul style="list-style-type: none"> • Adapted to food and beverage, pharmaceutical, river, and offshore applications • Stainless steel encoder (316) with hygienic design • Flanges and shaft adapted to the market needs 	<p>Counts the number of food elements being processed</p>
 <p>Compact External Fitting 1/2" NPT Taper Thread Float Switch</p>	<ul style="list-style-type: none"> • E15Compact design in 304 SS; external fitting; temperature range to 180°C • Flying lead or Plug and Socket connection 	<p>Catering oil level control and hot water level control</p>
 <p>2CP5 Pressure Sensors</p>	<ul style="list-style-type: none"> • Proven reliability with many customization options, overvoltage and short circuit protected • UL recognized, ceramic capacitive sensor, durable, compact, low-cost design, accurate performance over wide temperatures 	<p>Measures the air pressure of moving units</p>







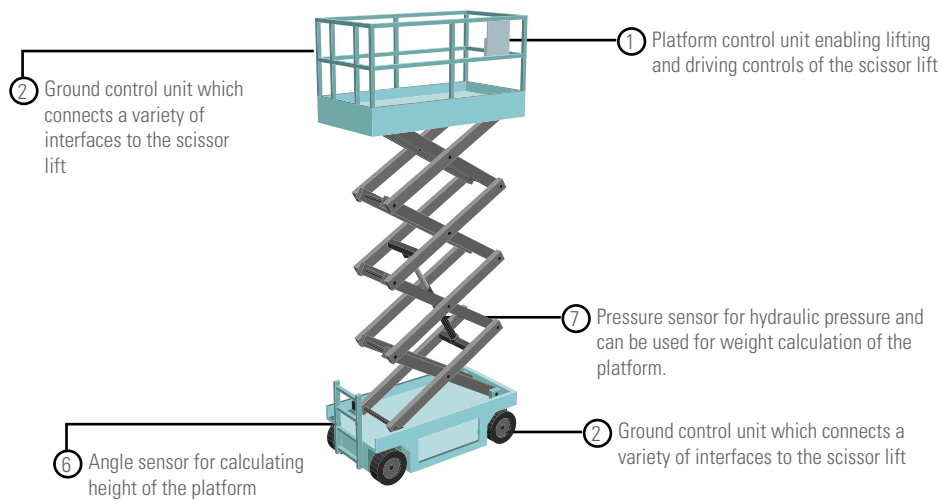

Mobile Elevated Work Platforms

Self-propelled scissor lifts, the most common type of mobile elevating work platforms, move vertically through folding supports known as the scissor mechanism. They are classified in two main categories based on how they are powered and where they are used. Battery powered (or electric) scissor lifts are used mainly indoors on slab surfaces, while the engine powered ones are used outdoors on rough terrain surfaces.

Regardless of how they are powered, they have many sensors and controls to manage movement, safety, and mainly stability (operators on the platform are subject to fall hazards, therefore safety is a priority). For decades, Sensata has been a market leading supplier of complete platform control systems for scissor lifts, either battery or engine powered.

All functions and movements can be controlled using Sensata's platform control systems and sensors to guarantee compliance with international safety standards.



①		PCU500 Platform Control Unit	<ul style="list-style-type: none"> The platform control unit includes the AJ11 joystick High reliability and accuracy, robust design, user friendly 	Ensures lifting and driving the rough terrain scissor lift
②		GCU500 Ground Control Unit	<ul style="list-style-type: none"> User friendly, LCD display, compact design CAN-bus communication system with 58 functionally configurable inputs/output 	Connects a variety of interfaces to the scissor lift
③		AJ11 Single Axis Joystick	<ul style="list-style-type: none"> Provides reliability and long life in heavy duty industrial applications High accuracy and stable output; high mechanical strength of the shaft and unique sensing design 	Single axis joystick for lifting and driving functions (used in PCU)
④		GV210 Contactor	<ul style="list-style-type: none"> Hermetically sealed for improved voltage isolation and switching Operates in explosive and harsh environments without damage to contacts. 	Protection against short circuit
⑤		9960 Hall Effect Rotary Position Sensor	<ul style="list-style-type: none"> Available in numerous standard configurations with fast delivery Available configurations include 7 termination options, single or dual outputs and 24 active electrical angles 	Angle sensor for calculating height of the platform.
⑥		PTE7100 Hermetic Analog Pressure Sensor	<ul style="list-style-type: none"> Measuring range from 0-50 bar to 0-400 bar, high accuracy Wide range of ports, connectors, and electrical outputs; stainless steel design with hermetic port 	Pressure sensor for hydraulic pressure and can be used for weight calculation of the platform.
⑦		T Series Industrial Inclinator	<ul style="list-style-type: none"> Compact, measuring inclination with excellent precision and at a high value Mechanical stability, encapsulated sensor, high environmental protection rating 	Measures the mechanical angle between the forklift and the floor
⑧		Optical Liquid Level Sensor with 1/4" NPT Float Switch Mount	<ul style="list-style-type: none"> Low cost general purpose liquid level sensors High reliability optical sensing External mount via 1/4" NPT thread. High and low output versions 	Optical level sensors that detect the level of hydraulic oil in fluid reservoirs.

Forklifts and Reachtrucks

Sensata's joysticks and fingertip solutions provide the accuracy, safety and durability required for forklifts, as well as the mechanical strength and the unique sensing design necessary for high performance applications moving materials high in the air.

Lift trucks are commonly used to move equipment in warehouses, requiring very accurate and ergonomic operator control systems. Moving materials high in the air demands high resolution and reliable control systems designed for the application. High mechanical strength, flexibility and a unique sensing design help performance under rigorous conditions; many components are involved to control it in the perfect way.

Sensata can help the fork truck operator work more efficiently by using single and dual axis ergonomic joysticks, switch rockers and analog rockers for operational control of lift trucks, draw wire encoders and angle sensors to monitor the fork height and pressure sensors to control the hydraulic circuits and brakes.

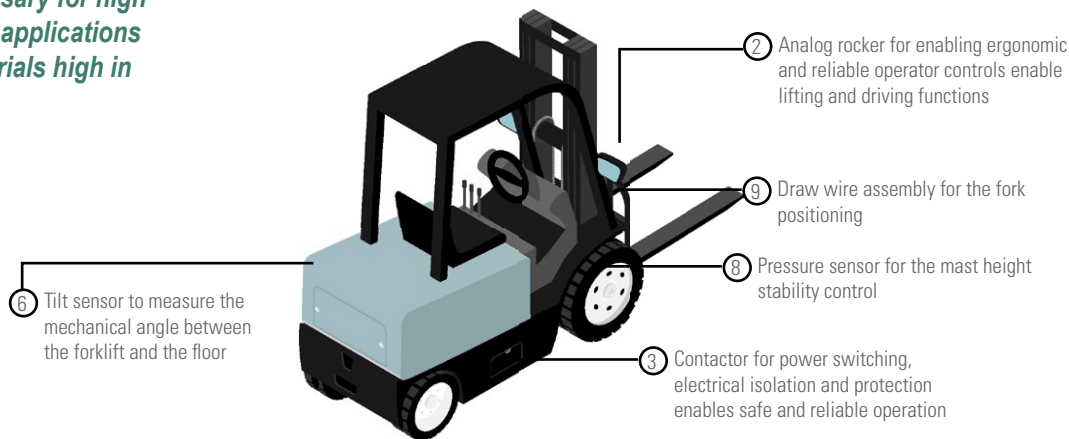

①	AJ3 Dual Axis Joystick	<ul style="list-style-type: none"> Provides the reliability and robustness require in heavy duty industrial applications High mechanical strength of the shaft; unique sensing design 	Enables lifting and driving functions
②	AR4 Analog Rocker	<ul style="list-style-type: none"> High reliability, using hall effect technology, with a unique design Ideal solution for fingertip rocker designs 	Enables lifting and driving functions
③	GV210 Contactor	<ul style="list-style-type: none"> Hermetically sealed for improved voltage isolation and switching Operates in explosive and harsh environments without damage to contacts. 	Power switching, electrical isolation and protection
④	DC100 SSR Solid State Relays	<ul style="list-style-type: none"> Resistance to shock and vibration and the capability to perform efficiently and consistently in harsh environments 	Control of battery cooling, buzzer and auxiliary functions
⑤	HHM3 Magnetic Incremental Encoders	<ul style="list-style-type: none"> Magnetic technology, contactless, robust, excellent resistance to shocks and vibrations. High protection level IP65, flanges and shaft adapted to the market needs. 	Steering command
⑥	T Series	<ul style="list-style-type: none"> Compact, measuring inclination with excellent precision and at a high value Mechanical stability, encapsulated sensor, high environmental protection rating 	Measures the mechanical angle between the forklift and the floor
⑦	ACW4 Hall Effect Position Sensor	<ul style="list-style-type: none"> Small package and easy integration; versatile due to the 360 degree turn capability Packaged in a highly sealed (IP69K) housing and utilizing non-contacting Hall effect technology 	Steering wheel angle
⑧	PTE7100 Hermetic Analog Pressure Sensor	<ul style="list-style-type: none"> Measuring range from 0-50 bar to 0-400 bar, high accuracy Wide range of ports, connectors, and electrical outputs; stainless steel design with hermetic port 	Pressure sensor for hydraulic pressure and can be used for weight calculation of the platform.
⑨	CD120 Series	<ul style="list-style-type: none"> Consists of a wire drum combined with a rotary sensor, commonly an encoder or a potentiometer The wire drum is mounted to the sensor so that as wire is extended or retracted it causes the sensor to rotate. 	Fork positioning
⑩	Optical Liquid Level Sensor with 1/4" NPT Float Switch Mount	<ul style="list-style-type: none"> Low cost general purpose liquid level sensors High reliability optical sensing External mount via 1/4"NPT thread. High and low output versions 	Optical level sensors that detect the level of hydraulic oil in fluid reservoirs.

Automated Guided Vehicles

The future of AGVs will undoubtedly be autonomous: systems that are adaptive and feature intelligence-based capabilities that allow them to respond within bounded domains to situations that were not pre-programmed in the design. Autonomous vehicles for use in factories, industrial facilities, retail outlets, warehouses, etc., can be categorized into four distinct 'types': forklift trucks (moving goods horizontally and vertically), pallet lift trucks (horizontal only), tow vehicles and unit load carriers (to convey heavy goods from conveyor to assembly line).

Hand-in-hand with the navigation and steering technologies comes a wide range of sensors that provide critical feedback to the control system about the AGV's surroundings and operation. The sensors used to navigate, like radar and cameras, and those used to control ground speed and direction, like encoders, are critical to ensure precise and safe operation.

Sensata's functional safety encoders rated to SIL3/PLe, Cat.4, are ideal for use in AGVs to ensure highest system safety, where they monitor ground speed and direction control.

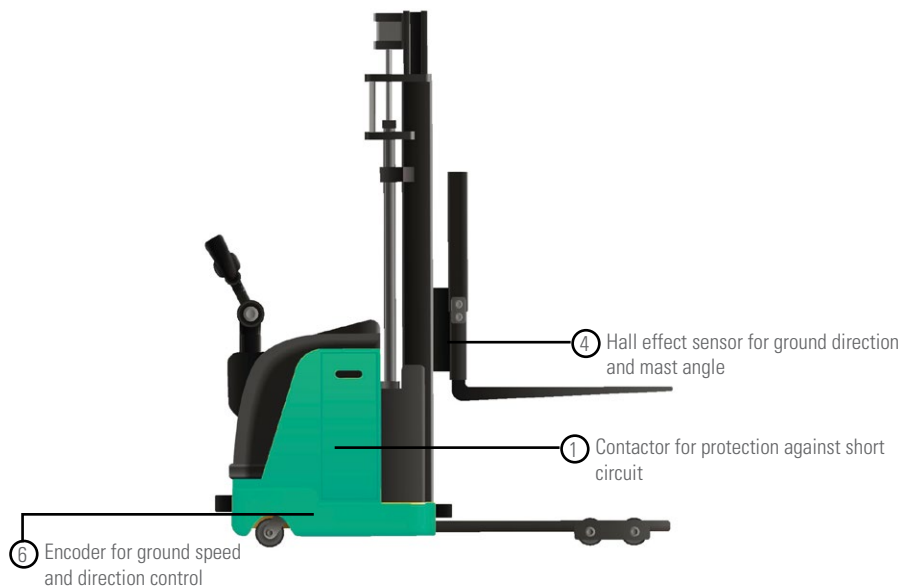







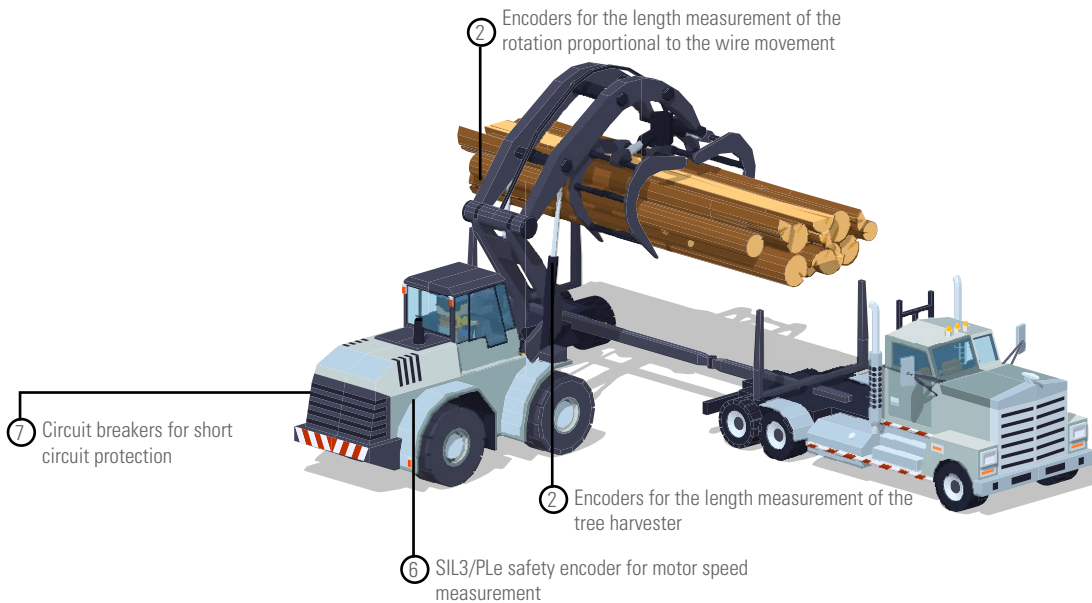

①	GV210 Contactor	<ul style="list-style-type: none"> Hermetically sealed for improved voltage isolation and switching Operates in explosive and harsh environments without damage to contacts. 	Protection against short circuit
②	TSD Tilt Sensor	<ul style="list-style-type: none"> High accuracy MEMS based inclination sensor, 32 bit microprocessor 	Tilt sensor for alarming if the machine is exceeding a specified angle
③	7100 Hermetic Analogue Pressure Sensor	<ul style="list-style-type: none"> Measuring range from 0-50 bar to 0-400 bar, high accuracy Wide range of ports, connectors, and electrical outputs; stainless steel design 	Used for weight calculation of the platform
④	9960 Series	<ul style="list-style-type: none"> Small package and easy integration; versatile due to the 360 degree turn capability Packaged in a highly sealed (IP69K) housing and utilizing non-contacting Hall effect technology 	Ground direction control and mast angle
⑤	CD120 Series	<ul style="list-style-type: none"> Consists of a wire drum combined with a rotary sensor, commonly an encoder or a potentiometer The wire drum is mounted to the sensor so that as wire is extended or retracted it causes the sensor to rotate. 	Determines mast height and fork positioning
⑥	DSM5H SIL3 Incremental Rotary Encoder	<ul style="list-style-type: none"> SIL3/PLe rated; hollow shaft / shafted versions; suitable for safe motor feedback Robust and excellent resistance to shock and vibration; High protection level: IP65 	Ground speed and direction control
⑦	Optical Liquid Level Sensor with M10 Float Switch Mount	<ul style="list-style-type: none"> Low cost general purpose sensor High reliability optical sensing. High and low output versions Internal mount via M10x1 thread 	Sensing the level of Hydraulic oil reservoirs

Woodworking Machinery

Sensors have an essential role in the safe and precise operation of the woodworking machines, as they increase automated operation without reducing machine versatility and safety.

Woodworking machines are intended to process wood and are usually powered by electric motors. High quality machines need to use best parts and materials to handle maximum capacity with ease and in the same time to ensure safe operation. These machines need a certain level of automation but also a degree of manual control. A wide variety of position, temperature sensors, vibration sensors and pressure sensors enable a flexible automation, faster speeds and higher precision, improving resource and energy efficiency as well as condition-based monitoring of machines and machinery components.



	<p>PTE7100/7300 Hermetic Analog Pressure Sensor</p> <ul style="list-style-type: none"> • Ideal for air compressors in the mid and high pressure ranges • Microfused Strain Gauge (MSG) with best-in-class accuracy • Wide range of ports, connectors, and analog electrical outputs for ease of integration in various industrial applications 	<p>Oil pressure measurement and monitoring of the general hydraulic system</p>
	<p>HHM3 Magnetic Incremental Encoders</p> <ul style="list-style-type: none"> • Magnetic technology, contactless, robust, excellent resistance to shocks and vibrations. • High protection level IP65, flanges and shaft adapted to the market needs. 	<p>Measures the length of the tree harvester</p>
	<p>DHM5 Programmable Incremental Encoders</p> <ul style="list-style-type: none"> • Easy programming without any specific software or hardware, robust, excellent resistance to shocks and vibrations 	<p>Monitors the speed of the machine</p>
	<p>CD120 Series</p> <ul style="list-style-type: none"> • Consists of a wire drum combined with a rotary sensor, commonly an encoder or a potentiometer • The wire drum is mounted to the sensor so that as wire is extended or retracted it causes the sensor to rotate. 	<p>Length measurement due to the rotation which is proportional to the wire movement</p>
	<p>T Series Industrial Inclinometer Analog</p> <ul style="list-style-type: none"> • Compact, measuring inclination with excellent precision and at a high value • Mechanical stability, encapsulated sensor, high environmental protection rating making these sensors ideal for measuring tilt in harsh industrial environments 	<p>Determines the inclination of the picking truck</p>
	<p>SIL3 Incremental Rotary Encoder</p> <ul style="list-style-type: none"> • Usable up to SIL3/PLe, suitable for safe motor feedback, especially designed for heavy-duty applications • Compact and robust, excellent resistance to shock and vibration, stainless steel version available 	<p>Speed of the motor, with SIL3/PLe safety performance level</p>
	<p>Circuit Breakers</p> <ul style="list-style-type: none"> • Cost effective power switching, reliable and accurate circuit control • Enables precision operation and is not affected by ambient environment 	<p>Short circuit protection</p>
	<p>GV210 Contactors</p> <ul style="list-style-type: none"> • Hermetically sealed for improved voltage isolation and switching • Operates in explosive and harsh environments without damage to contacts. 	<p>Short circuit protection</p>





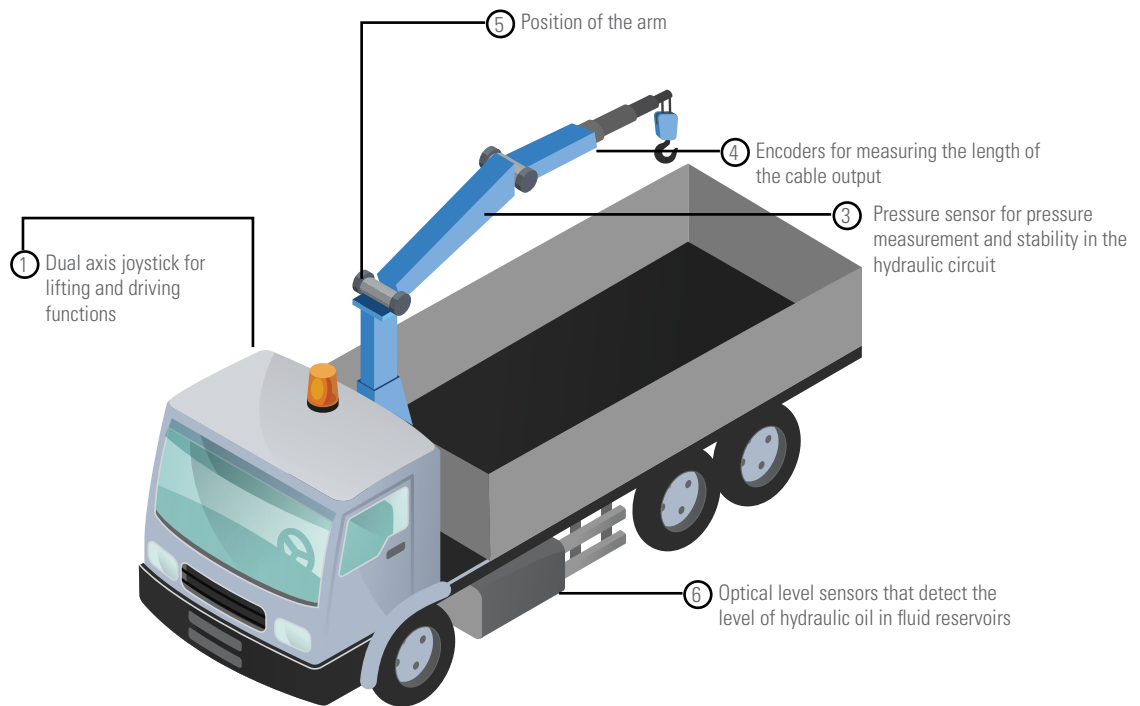

Mobile Boom Cranes

Mobile boom cranes can be used in construction, landscaping, demolitions and a whole lot of other, similar activities. Like all cranes, the crane operator needs to keep close track of the weight they are handling, the angle of the boom and how far out the boom extension is. Without careful attention to these three things, there is a significant risk that the boom will be overloaded and collapse or cause the whole mobile platform to tip over.

One of the most critical parameters to keep track of is the boom extension. For small booms like the one shown the one shown, installing a Draw-Wire assembly with an optical encoder is the perfect solution. As the boom is extended or retracted, the end of the Draw-Wire will move right along with it and the operator can tell exactly how much the boom has been extended. Together with the weight and the angle (using other measuring devices) the operator can stay completely in the safe zone.

As the boom is extended or retracted, the end of the Draw-Wire will move right along with it and the operator can tell exactly how much the boom has been extended



	<p>AJ3 Dual Axis Joystick</p> <ul style="list-style-type: none"> High strength Hall-effect sensing joystick provides reliable control in rugged, harsh environments 	<p>Lifting and driving functions</p>
	<p>AJ11 Single Axis Joystick</p> <ul style="list-style-type: none"> Joystick that provides reliability and long life in heavy duty industrial applications. 3D hall effect sensors provide high accuracy and stable output. The high mechanical strength of the shaft and the unique sensing design make the joystick ideal for rigorous use in rugged, harsh environments. 	<p>Lifting and driving functions</p>
	<p>7100 Hermetic Analogue Pressure Sensor</p> <ul style="list-style-type: none"> Measuring range from 0-50 bar to 0-400 bar, high accuracy Wide range of ports, connectors, and electrical outputs; stainless steel design 	<p>Pressure sensor for pressure measurement and stability in the hydraulic circuit</p>
	<p>DH05 Optical Incremental Encoder</p> <ul style="list-style-type: none"> Hollow shaft, programmable resolution, easy mounting for the hollow shafts thanks to the anti-coupling device Robustness and excellent resistance to shocks / vibrations, high protection level IP65, high resolutions available 	<p>Measures of the length of the cable output</p>
	<p>ACW4, TCW4 I/O Link Hall Effect Position Sensors</p> <ul style="list-style-type: none"> Two-part design, offering maximum flexibility during installation Easy commissioning and configuration with IO-Link, simple device replacement with data storage capability 	<p>Position of the arm</p>
	<p>OLS7 Optical Liquid Level Sensor with 1/4" NPT Float Switch Mount</p> <ul style="list-style-type: none"> Low cost general purpose liquid level sensors High reliability optical sensing External mount via 1/4" NPT thread. High and low output versions 	<p>Optical level sensors that detect the level of hydraulic oil in fluid reservoirs</p>





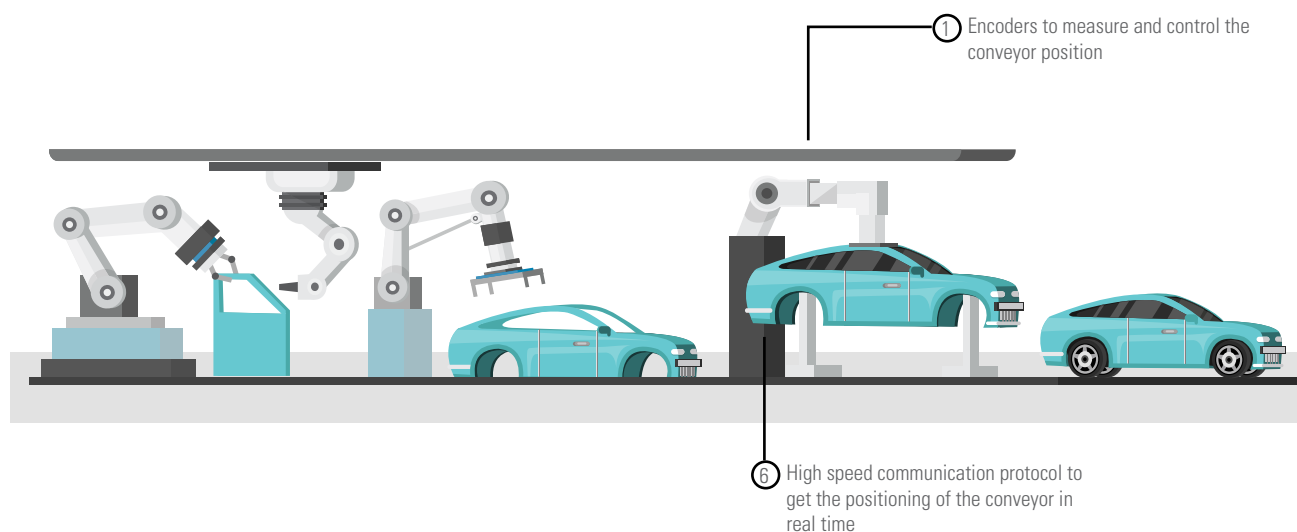

Assembly Equipment, Robotics and Cobotics

Sensors are mandatory in assembly lines for transportation equipment, household appliances and electronic goods, as they help the automated process work safely, precisely and efficiently.

Assembly lines, also called as progressive assembly, is a process where parts are added in as the semi-finished assembly moves from workstation to workstation. Parts are added in sequence until the final assembly is produced. By mechanically moving the parts to the assembly work and moving the semi-finished assembly from workstation to workstation, a finished product can be assembled faster and with less labor than by having workers carry parts to a stationary piece for assembly.

Assembly lines are used particularly to assemble complex items such as cars and other transportation equipment, household appliances and electronic goods. These are machines require sensors to do the automated work safely, precisely and efficiently.



1	 DSU9H Series	<ul style="list-style-type: none"> Secure positive lock mounting Standard incremental output 	Measures and controls position of the robot arms
2	 2CP5 Pressure Sensors	<ul style="list-style-type: none"> UL recognized ceramic capacitive sensor, overvoltage and short circuit protected Durable, compact, low-cost design, with accurate performance over wide temperatures 	Measures the air pressure in the pneumatic cylinders attached to the robots
3	 PTE7100, PTE7300 Hermetic Analogue and Digital Pressure Sensors	<ul style="list-style-type: none"> Simple cable replacement system. Universal Configurable Analogue Input Expand the number of inputs through the use of IsoSlice I/O Modules MODBUS TCP or RTU Protocol. Ethernet or RS232/485 Comms Port 	Measures the liquid pressure in the hydraulic cylinders attached to the robots
4	 E-100 & Isoslice System	<ul style="list-style-type: none"> Measuring range from 0-16 bar to 0-400 bar, high accuracy Low power consumption and fast response time, good electromagnetic noise resistance 	Gathers vibration and temperature data and connects via Ethernet to local network
5	 TCW4 Series	<ul style="list-style-type: none"> Two-part design, offering maximum flexibility during installation Easy commissioning and configuration with IO-Link, simple device replacement with data storage capability 	Measures and controls position of the conveyor
6	 MHM5 Series	<ul style="list-style-type: none"> ProfiNet; EtherCAT; EtherNet/IP; absolute encoders produce a digital word value indicating true position within a full 360° rotation Ideal for position control, especially if power outages or long periods of inactivity are expected 	High speed communication protocol permitting to get the positioning of the conveyor in real time
7	 PHM5 Series	<ul style="list-style-type: none"> CanOpen, ProfiBus extra-flat encoder, robust, excellent resistance to shocks and vibrations, high protection level IP65 High performances in temperature -20°C to +85°C 	High speed communication protocol to get the positioning of the conveyor in real time

Conveyor Belt Systems

Conveyor belts are at the core of factory automation. They move products from point A to point B in an efficient manner, while also allowing the items that travel on it to be sorted, augmented or modified in some way. Factory outfitters and manufacturers are looking for ways to decrease wear and tear, increase capabilities and improve communication of conveyor belt systems.

Position sensors are at the core of the conveyor systems and our solutions help reduce maintenance and downtime, while improving control and safety of the system.

Position sensors are used to control the movement of the belt system and to keep workers safe by limiting the maximum conveyor speed.

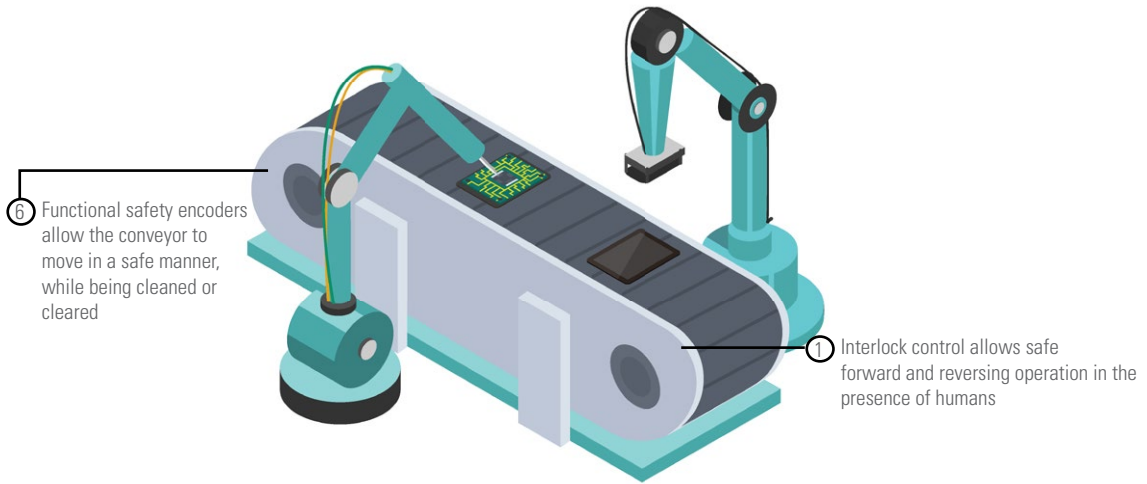

⑥ Functional safety encoders allow the conveyor to move in a safe manner, while being cleaned or cleared

① Interlock control allows safe forward and reversing operation in the presence of humans

①	 SOLICON DRC Solid State Contactor	<ul style="list-style-type: none"> Developed for frequent switching on 3-phase loads Built-in overvoltage protection and ultra-efficient thermal management design 	Interlock control allows safe forward and reversing operation in the presence of humans
②	 DRMS Series Hybrid Motor Starter	<ul style="list-style-type: none"> Soft start, soft stop, and motor reversing functions in a compact 22.5mm package Built-in overload protection and optional mains isolating relay 	Its functions extend the lifetime of the conveyor systems, while the motor functions offer additional control on the movement of the belt
③	 DRA3R/DRA3P Series Solid State Relay	<ul style="list-style-type: none"> 61mm wide DIN rail package which doesn't require heat sinking up to 60°C Ideal low-cost option for conveyor systems 	Switching loads and motor reversing for small 3-phase AC motors up to 2 HP
④	 DP Series	<ul style="list-style-type: none"> It can be used in demanding DC applications that require frequent switching It has an LED input status indicator that shows which direction control (forward, reverse) is being activated 	Reversing control and optional soft start, soft stop functions
⑤	 H25 Series	<ul style="list-style-type: none"> Heavy duty precision bearings, meets NEMA 4 and 13 requirements Designed from the ground up for the industrial marketplace 	Sensing and coordination of conveyor speed with other parts of the system in the loop
⑥	 DSM Series Safety Encoders	<ul style="list-style-type: none"> SIL3 / Cat. 4 PLe rated; IP65 (IP69k functional safety encoders available) Shafted and Hollow versions available 	Cleaning or clearing conveyor jams means downtime and reduced productivity. Functional safety encoders allow the conveyor to move in a safe manner, while being cleaned or cleared.
⑦	 Electronic Anti-Dither Module	<ul style="list-style-type: none"> Logic gates in the Anti-Dither Module use the quadrature relationship to discriminate between dithering and actual movement 	Permit to remove spurious counts caused by mechanical vibration
⑧	 Broadcaster Module	<ul style="list-style-type: none"> Broadcasts encoder signals to up to four independent receivers Signal processing modules can be added to each output for additional capabilities Accepts single ended, differential and open collector input voltages 	Broadcasts encoder signals to up to four independent receivers
⑨	 IHM5 Series	<ul style="list-style-type: none"> SIL3/PLe rated; hollow shaft / shafted versions; usable up to SIL3/PLe; suitable for safe motor feedback Robust and excellent resistance to shock and vibration; High protection level: IP65 	Safe motor feedback
⑩	 ACW4/TCW4 Series	<ul style="list-style-type: none"> Two-part design, modular, offering maximum flexibility during installation; IO-Link with COM3 transmission rate Easy commissioning and configuration with IO-Link; Simple device replacement with data storage capability 	Conveyor speed measurement





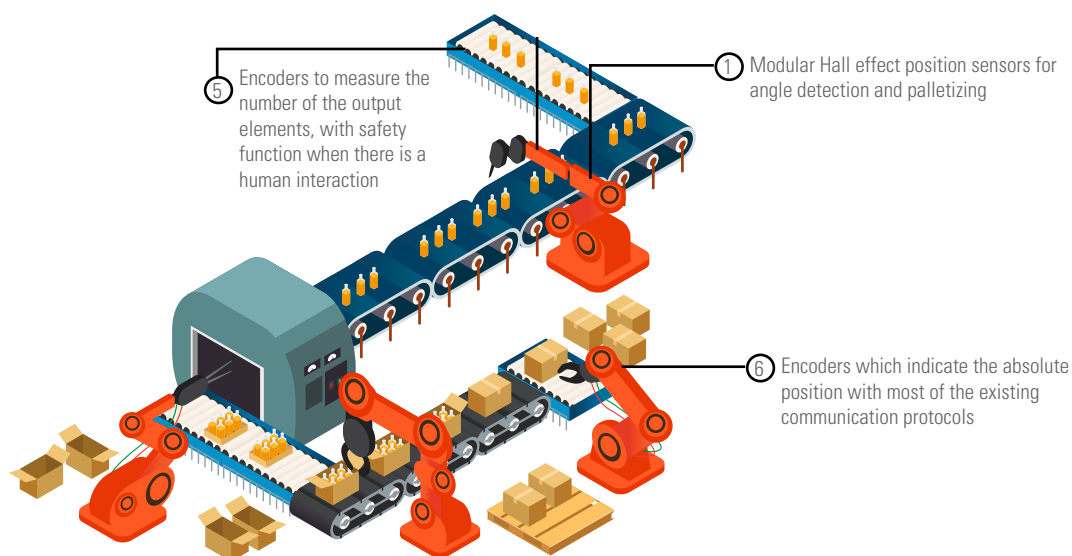

Packaging, Sorting And Palletizing

The strength of IO Link is its configuration simplicity and the diagnostic features

Packaging has some very complex automation needs: all the way from die cutting, carton erecting, filling, inspecting and closing, to multi-packing and palletizing. In addition to these actions, which require split second timing, there is also the need to reconfigure equipment to accommodate runs of different material or to perform operations on packages of different dimensions. In short - versatility, simplicity and configurability are key.

The IO Link system was built with automation in mind. It has a simple master-slave structure, hubs that can be used to share signals with the master and either actuators (outputs) or sensors (inputs) can be plugged in through a handful of standard plug configurations. Sensors and actuators can be configurable to report information that can be used for diagnostics and/or analysis for preventative maintenance programs. Products can be reconfigured on the fly. Sensata sensors with I/O link support Industry 4.0 objectives and the 24volt standard.



①	 ACW4/TCW4 Series	<ul style="list-style-type: none"> Two-part design, modular, offering maximum flexibility during installation; IO-Link with COM3 transmission rate Easy commissioning and configuration with IO-Link; Simple device replacement with data storage capability 	Angle detection and palletizing
②	 DRA3R/DRA3P Series Solid State Relay	<ul style="list-style-type: none"> Built-in overvoltage protection, LED input status indicator Wide range of AC and DC control voltage options, cage style screw terminals for easy installation 	Voltage on and off switching for motor protection, leading to energy savings
③	 DR22 Series	<ul style="list-style-type: none"> The configurations of these relays offer versatility and the possible use of plug-in connector for the control input, in either standard "screw" or "spring cage" terminals Powerful and ready to use SSRs, coming with an integral heat sink, eliminating the need for complex thermal calculations 	Voltage on and off switching for motor protection, leading to energy savings
④	 DH05 Series	<ul style="list-style-type: none"> Hollow shaft, programmable resolution, easy mounting for the hollow shafts thanks to the anti-coupling device Robustness and excellent resistance to shocks / vibrations, high protection level IP65, high resolutions available 	Measures the number of the output elements
⑤	 IHM5 Series	<ul style="list-style-type: none"> SIL3/PLe rated; hollow shaft / shafted versions; usable up to SIL3/PLe; suitable for safe motor feedback Robust and excellent resistance to shock and vibration; High protection level: IP65 	Measures the number of the output elements, with safety function when there is a human interaction
⑥	 MHM5 Series	<ul style="list-style-type: none"> ProfiNet; EtherCAT; EtherNet/IP; absolute encoders produce a digital word value indicating true position within a full 360° rotation Ideal for position control, especially if power outages or long periods of inactivity are expected 	Indicates the absolute position with most of the existing communication protocols
⑦	 PHM5 Series	<ul style="list-style-type: none"> CanOpen, ProfiBus extra-flat encoder, robust, excellent resistance to shocks and vibrations, high protection level IP65 High performances in temperature -20°C to +85°C 	Indicates the absolute position with most of the existing communication protocols

Solid State Relays in Packaging Equipment

Due to the high level of automation used in packaging lines, there is an intensive use of advanced electronic components, which need to meet very strict requirements specific to each industry.

Whatever products need to be packaged and whichever the materials used, Sensata | Crydom offers an extensive line of Solid State Relays and Contactors, which are ideal solutions for heating and AC or DC motor control, increasing the efficiency and reliability of high performance packaging equipment in operations such as filling & closing, formfill-sealing, wrapping and palletizing, among others.

SSRs provide many advantages against EMRs, such as higher life expectancy, higher resistance to shock and vibration, faster switching and better noise immunity.

Solid State Relays are an excellent option in applications where there is a need for precise temperature control or where there are constant starts and stops. They can be used to control heaters, motors, fans/blowers, and valves, as well as many other types of loads.

Solid State Relays are ideal solutions for heating and AC or DC motor control, increasing the efficiency and reliability of high performance packaging equipment.

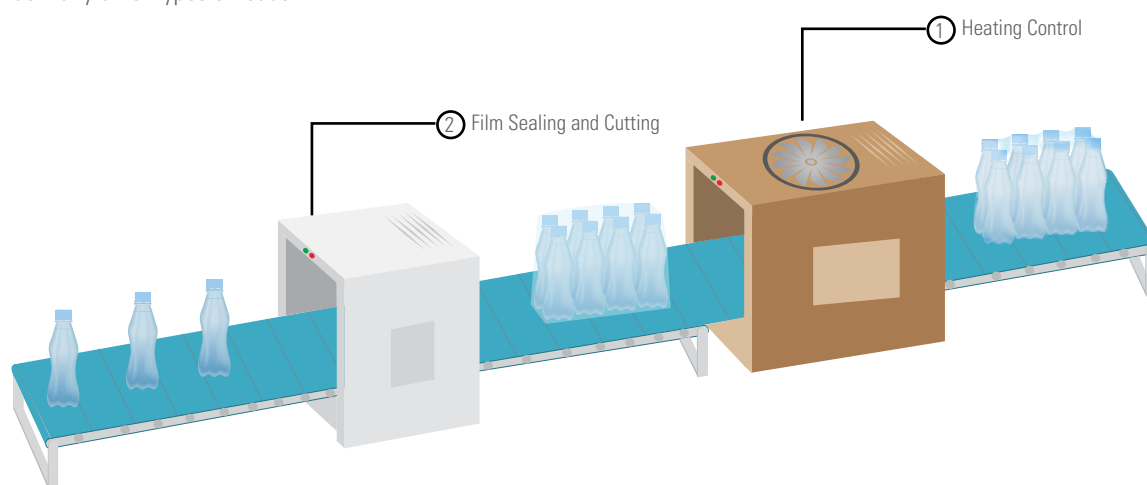

①



DR22 Series

- DIN Rail Mount single phase solid state relay
- 20 to 35 Amp ratings
- Available with back-to-back SCR or cost-effective TRIAC output
- Built-in overvoltage protection

Heating Control

②



SeriesOne DR

- Compact DIN Rail Mount solid state relay
- 3 to 12 Amp ratings
- Class I Div 2 rated

Film Sealing and Cutting

③



DP4R Series

- DC Motor Reversing Contactor
- 20 to 60 Amp ratings
- Soft Start, Soft Stop & Braking Functions
- Built-in interlock circuit

Conveyor Motor Control

⑤



DRC3P & DRC3R Series

- Solid State Contactor
- For 3-phase motors up to 5HP (3.7kW)
- Available with auxiliary contacts
- Built-in overvoltage protection

Conveyor Motor Control
Fan On/Off Control

Americas

SENSATA TECHNOLOGIES INC.
529 Pleasant Street,
Attleboro, MA 02703
USA

PRESSURE SENSORS & SWITCHES
+1 (800) 350 2727
sensors@sensata.com
switches@sensata.com

TEMPERATURE SENSING
+1 (888) 438 2214
sensors@sensata.com

POSITION SENSORS AND ENCODERS
+1 (800) 350 2727
sales.beisensors@sensata.com

SOLID STATE RELAYS
+1 (877) 502 5500
sales.crydom@sensata.com

MOTORS & ACTUATORS
+1 (760) 597 7042
sales.beikimco@sensata.com

OPERATOR CONTROLS
+1 (800) 350 2727
sales.deltatech@sensata.com

ELECTRICAL PROTECTION /POWER CONTROLS
+1 (508) 236 3287
klixon@sensata.com

GIGAVAC CONTACTORS
Phone +1 (805) 684-8401
gigavac@sensata.com

CYNERGY3 COMPONENTS
+44 (0) 1202 897969
sales@cynergy3.com

Europe, Middle East & Africa

SENSATA TECHNOLOGIES HOLLAND B.V.
Jan Tinbergenstraat 80
7559 SP Hengelo
The Netherlands

PRESSURE SENSORS & SWITCHES
+359 (2) 809 1826
pressure-info.eu@sensata.com

TEMPERATURE SENSING
+359 (2) 804 7165 (Klixon)
+31 (74) 357 8156 (Airpax)
temperature-info.eu@sensata.com

POSITION SENSORS AND ENCODERS
+33 (3) 88 20 8080
position-info.eu@sensata.com

SOLID STATE RELAYS
+44 (1202) 416170
ssr-info.eu@sensata.com

MOTORS & ACTUATORS
+1 (760) 597 7042
motors-info.eu@sensata.com

OPERATOR CONTROLS
+359 (2) 809 1826
ost-info.eu@sensata.com

ELECTRICAL PROTECTION /POWER CONTROLS
+31 (74) 357 8156
temperature-info-eu@sensata.com

GIGAVAC CONTACTORS
Phone + (805) 684-8401
gigavac@sensata.com

CYNERGY3 COMPONENTS
+44 (0) 1202 897969
sales@cynergy3.com

Asia Pacific

SENSATA TECHNOLOGIES CHINA CO., LTD.
30th Floor, InterContinental Center,
100 Yu Tong Rd, Jing An District, 200070
Shanghai, China
+86 (21) 2306 1500
sales.isasia@list.sensata.com

JAPAN
+81 (45) 277 7117
sales.isasia@list.sensata.com

KOREA
+82 (31) 601 2004
sales.isasia@list.sensata.com

INDIA
+91 (80) 67920890
sales.isasia@list.sensata.com

REST OF ASIA
+886 (2) 27602006 ext 2808
sales.isasia@list.sensata.com

ELECTRICAL PROTECTION/POWER CONTROLS
+86 (21) 2306 1500
AIRPAXSH@sensata.com (Airpax)
EP_Asia_Public@list.sensata.com (Electrical Protection)

GIGAVAC CONTACTORS
Phone + (805) 684-8401
gigavac@sensata.com

CYNERGY3 COMPONENTS
+44 (0) 1202 897969
sales@cynergy3.com