

Sidewinder AC Current Sensor

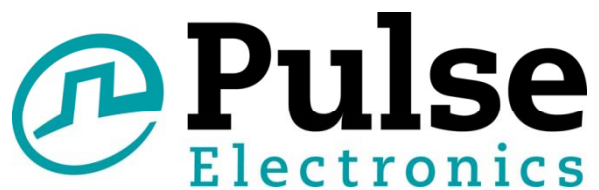

G043.B (6/12)

Rogowski Coil Fundamentals

- Sidewinder Current Sensor is based on the Rogowski Coil Principle
- When an AC current flows through the center of the sensor, an output voltage is induced, that is proportional to the rate of change of the current, $di(t)/dt$

$$v(t)_{\text{out}} = -M di(t)/dt$$

where $M = \mu_0 sn$

μ_0 = permeability of air = $4\pi \cdot 10^{-7}$ H/m

s = cross sectional area of a turn (m^2)

n = number of turns per unit length (m)

Discovered by W. Rogowski in 1912

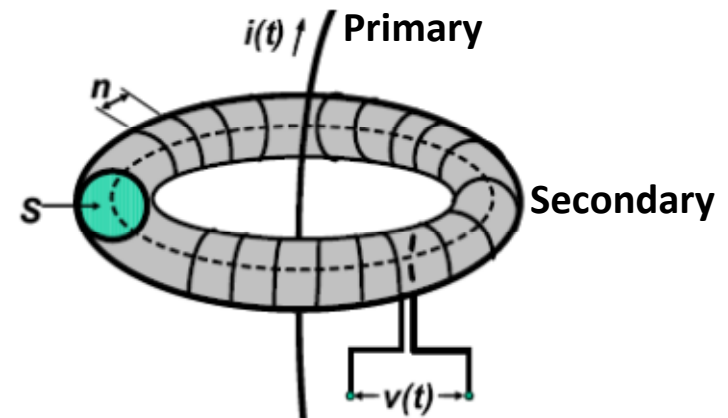

Current Sensing Focus on Metering

- AC current sensor, for 50/60Hz, 120/240V Single Phase applications
- Designed to provide a highly linear output voltage over a very wide dynamic range of 3000:1
- Meets the Class 0.2 percent accuracy limits for currents from 0.1 A to 200A and above for IEC 60044 and ANSI C12.20
- Patent Pending design provides immunity to external magnetic fields
 - Per IEC 62053-21 and 62053-22, Table 6, Class 0.5
 - Per ANSI C12.1 and C12.20, Test 18
- Additional Faraday shield provides immunity to external voltage fields
- Coreless design provides lower cost than a CT
- Very high bandwidth AC Sensor from 1 Hz up to 1MHz and higher
- Suitable for Arc Fault Sensing in high current applications

Technology Comparison

Characteristic	Shunt	Current Xfmr	Hall Effect	Rogowski Coil
Linear Amplitude & Phase	++	0	-	++
Wide Range – 5 decades	0	0	+	++
High Saturation Current	-	--	-	++
Wide Bandwidth	+	0	0	+
DC Immunity	++	-	-	++
Temperature Independent	-	+	-	++
Low Power Consumption	-	+	0	++
Low Cost	++	0	-	+
Tamper resistant	+	-	0	+
Light Weight	+	-	+	+
Flexible size & shape	0	-	+	++

Pulse Sidewinder Products

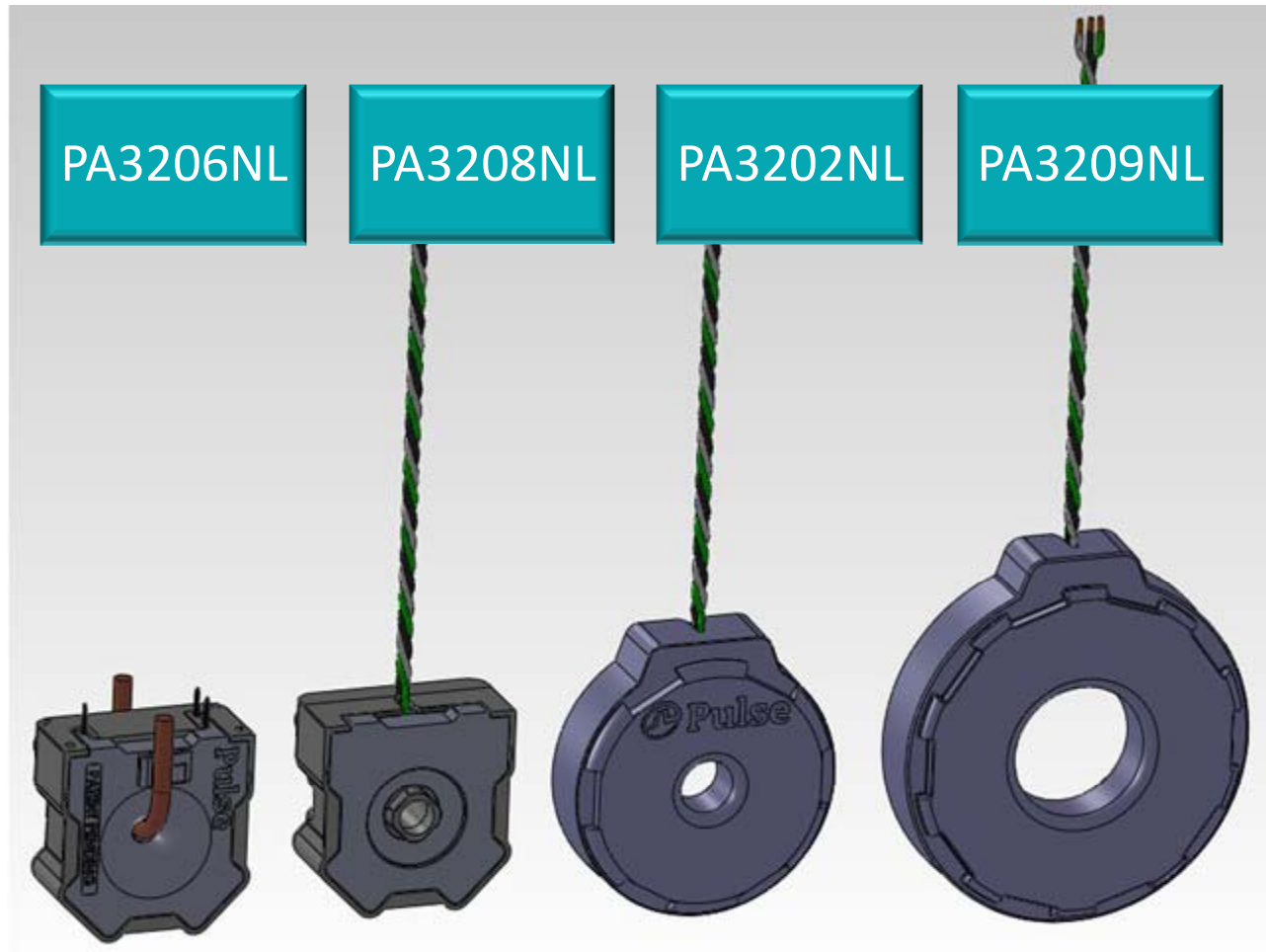

Pulse Sidewinder Products

Pulse has 4 current sensors in the Sidewinder product family

	Part	Accuracy Class	Output Level @ 50Hz	Output Level @ 60Hz	Current Range (see note)
	PA3202NL	0.2 %	416 $\mu\text{V/A}$	500 $\mu\text{V/A}$	0.1 A – 200 A
New	PA3206NL	0.2 %	383 $\mu\text{V/A}$	460 $\mu\text{V/A}$	0.1A – 40 A
New	PA3208NL	0.2 %	383 $\mu\text{V/A}$	460 $\mu\text{V/A}$	0.1A – 120 A
New	PA3209NL	0.2 %	463 $\mu\text{V/A}$	556 $\mu\text{V/A}$	0.1 A – 1000 A

Note: The current range is limited by the maximum current of the buss bar through the hole. The Rogowski Coil sensor has no core and cannot saturate, and therefore there is no maximum current for the sensor, only for the buss bar.

Pulse Current Sensor

Low Frequency Equivalent Circuit

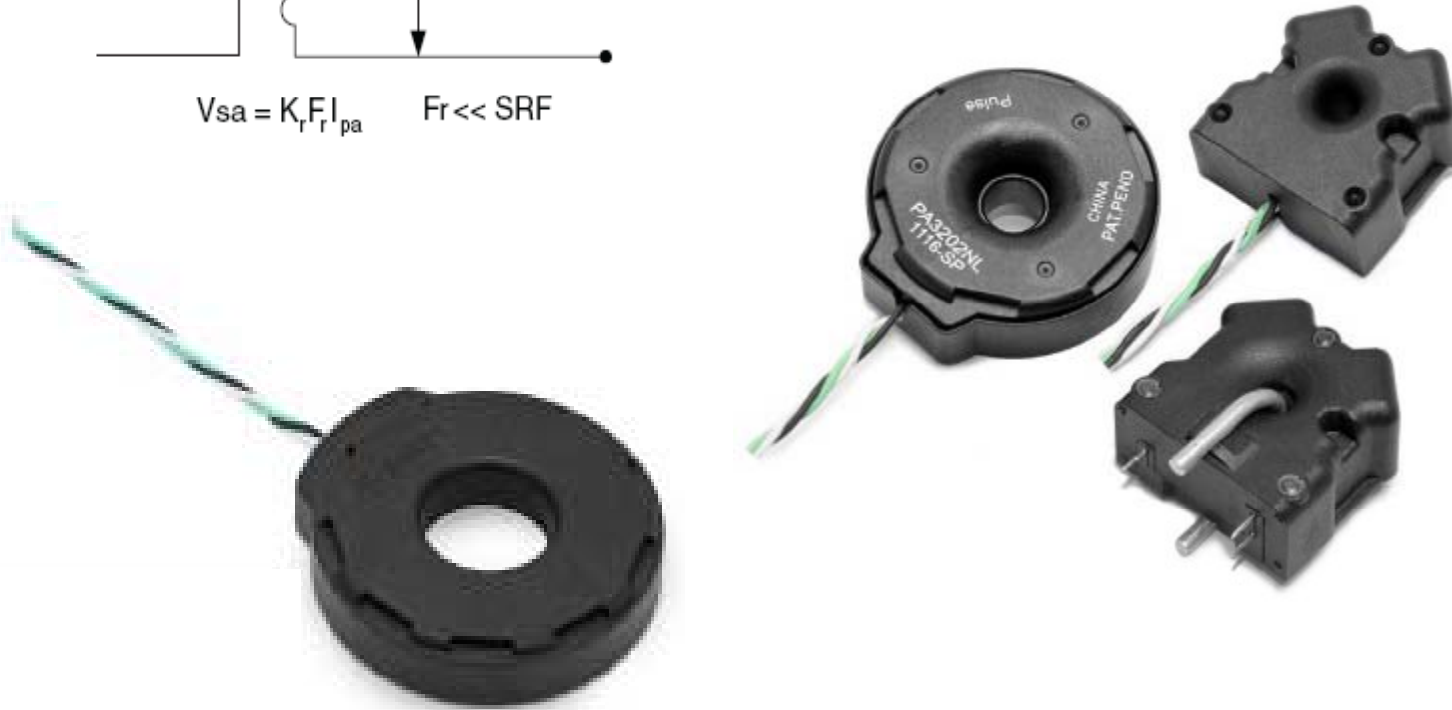
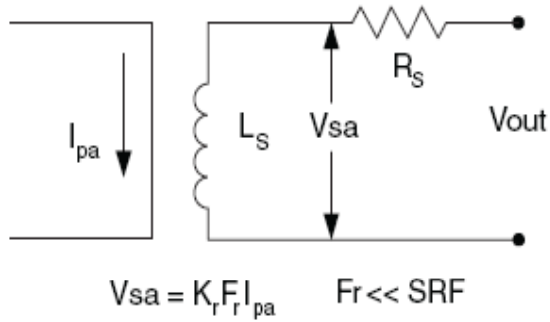

Sidewinder Application Notes

- Black wire is connected to the Current Plus pin I+
- Connect the White wire and the Green wire together, and then connect them to the Current Negative pin, I-
- No burden resistor is required
- Requires an IC that supports Rogowski Coils

Vendor	IC Families
Analog Devices	ADE7753, ADE7878
Cirrus Logic	CS5480, CS5484, CS5490
IDT	90E32, 90E36
Maxim (Teridian)	71M6531, 71M6533
ST Micro	STPM01
Texas Instruments	MSP430FE42xA

Contact Information

More information is available at
www.PulseElectronics.com/Sidewinder

Contact Glenn Roemer at
email: groemer@pulseelectronics.com



*Content is subject to change without notice
©2011 All Rights Reserved*

