

DESIGN OF HIGH POWER PLANAR MAGNETICS FOR A 1.8KW PHASE SHIFTED FULL BRIDGE CONVERTER USING ADVANCE FEA ELECTROMAGNETICS TOOLS

Abstract

There is an important requirement in high-power converter applications for highly efficient yet small power magnetics. It is commonly believed that complicated and dense 3D finite element analysis (FEA) models are required to accurately analyze and design high-power magnetics. In contrast, here we propose a novel design methodology using 2D FEA approximations, that produces results quickly and accurately. We analyze two of the magnetics (phase-shifted full bridge transformer and output inductor) used in a 1.8kW DC/DC inverter for HEV/EV automotive applications.

Overview of Phase Shifted Full Bridge Converter

Due to the increased design activity for electric vehicles, we are receiving many more requests to design magnetic parts in applications using phase-shifted full bridge (PSFB) and LLC converters. Both of these topologies are used for high power applications (400W to 12kW). The PSFB converter is well suited to DC/DC inverters converting the 400v battery pack rails to the lower 12v system rails. The LLC converter is used for on board charger circuits to convert the AC charge to the 400v battery pack voltage. For this presentation, we discuss the PSFB converter. The main components integrating this topology are a full bridge array of switches, an isolation stage, and a rectifier at the output. For magnetics, the PSFB requires careful design of the isolated power transformer, the resonant inductor and the output inductor. Next, we will illustrate the design process of the power transformer and output inductor for this converter using 2D FEA models.

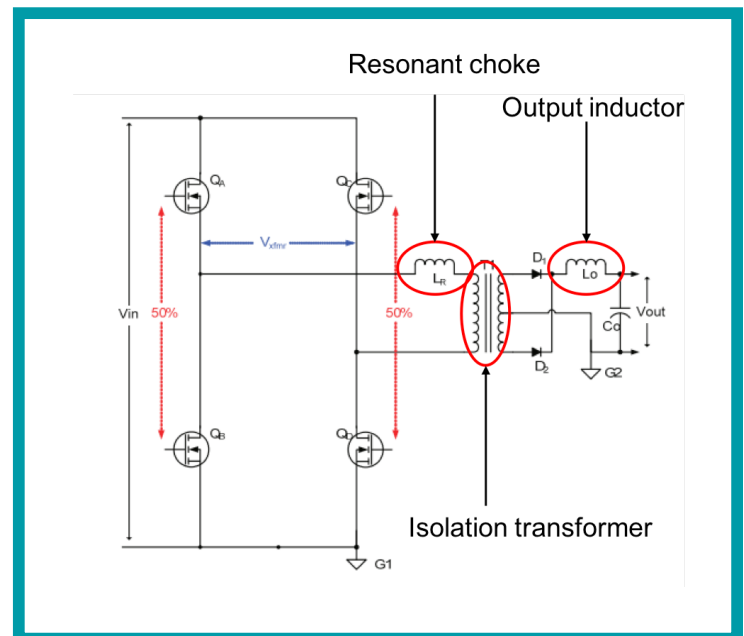

Figure 1

Before we examine the details of the design and optimization of the magnetic components, we discuss the most relevant specifications for the converter in question. This system is required to have a power rating of 1.8KW, with a voltage range input of 280V-400V, a voltage output of 14V, and an operating frequency of 100kHz. It is required that the power transformer meets a 12:1 turn ratio, which will be connected to a full wave rectifier across its secondary terminals. As a result, there must be two separate secondary windings at the output. Also, the output inductor is required to meet an inductance of 2.1uH with a maximum saturation current of 170 Amps.

Now that we have reviewed the specifications of the PSFB converter, we are ready to examine the design process of the main power isolation transformer and the output inductor.

When designing high power planar transformers, it is difficult to find tools and calculation methods that will yield to accurate loss prediction. Commonly known approaches such as Dowell’s equations, work better with concentric windings, than with vertically stacked windings. Therefore, here we propose a design methodology that relies merely in 2d FEA tools and allow the designer to quickly identify the best winding topology/interleaving strategy and then calculate the true loss of the transformer. Figure 2 above, shows a simplified block diagram of the proposed design methodology for the isolation transformer of the PSFB converter described above.

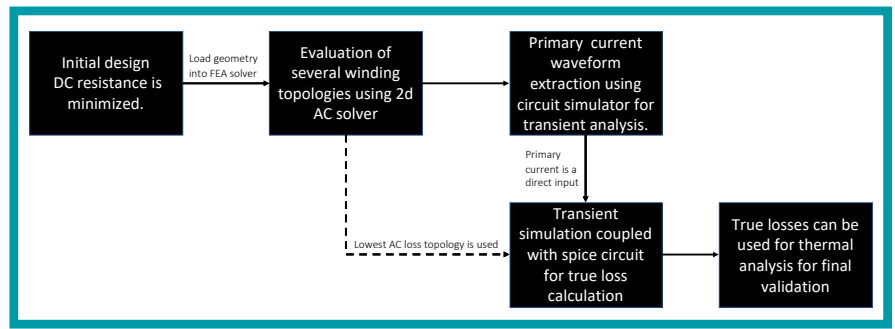

Figure 2

For this transformer, we performed a first iteration using traditional calculation methods. The initial winding topology is chosen to lower the DC resistance by using wide flat coils. Also, because there are two secondary windings they are placed so that they sandwich the primary as shown in Figure 2.

NOTE Due to the full wave rectifier at the output, only one secondary at a time will conduct current, and therefore, there is no effective winding interleaving in this configuration as it is.

At high frequency, there will be skin and proximity losses in the transformer. Therefore, it is crucial to select an optimal interleaving strategy. For this purpose, we use the 2D eddy current solver (AC analysis) within Ansys Maxwell which allows the user to calculate AC losses at any frequency based on sine waves. Note that the true loss of the transformer in the application will not be calculated accurately at this stage. However, the 2D eddy current solver will provide us with enough information to select the most suitable interleaving winding strategy.

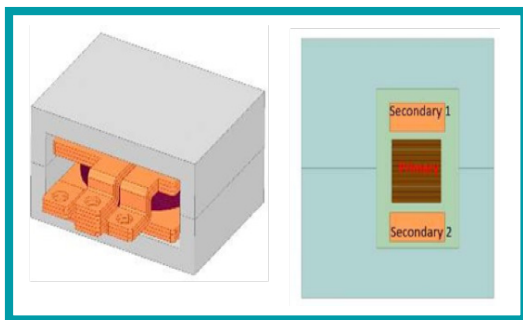

Figure 3

IMPORTANT The main reason for using this approach at this stage is the speed at which one can evaluate different design iterations without having to wait long periods of time for each set of results.

As an initial step, a 2D FEA axisymmetric model of the first iteration design is solved using the 2D eddy current solver. A closer look at the plot of the current distribution with a load of 1 Amp in the primary Figure 4 shows that there is significant current crowding in both windings. Also we are able to extract the total AC loss of the structure for this case, which will be used as a figure of merit for comparison against other winding topologies.

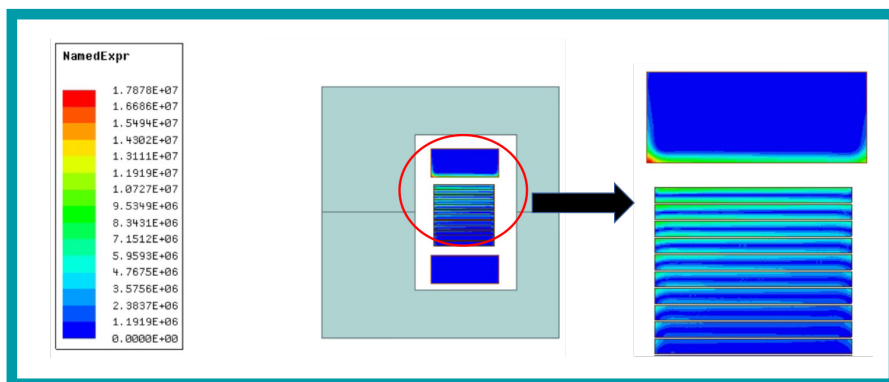

Figure 4

For the next step, we evaluated three additional winding configurations by splitting and moving windings around. Their corresponding current distributions and AC losses appear below in Figure 5 and Table 1.

After examining the current distribution plots, we can conclude that either C3 or C4 will be a better option for this design. Also, when we compare the total AC loss for all four configurations, we see that C3 will provide an estimated loss reduction of about six times compared to C1, C3 is then chosen to move forward as a final design. Furthermore, it is now of interest to calculate the true winding loss of C3, and C1 with real conditions so that the efficiency improvement can be quantify accurately.

To calculate the true winding loss a transient simulation must be set up so that the current waveforms flowing through the windings are the of the exact shape and magnitude of what will be seen in the actual converter application. For this purpose, we will couple the finite element model with the spice circuit editor within the FEA tool itself. To keep the simulation lean, only the secondary part of the circuit is modelled, and the primary current waveform is extracted from a commercially available circuit simulator (ETA designer), and then directly applied to the primary winding in the FEA model.

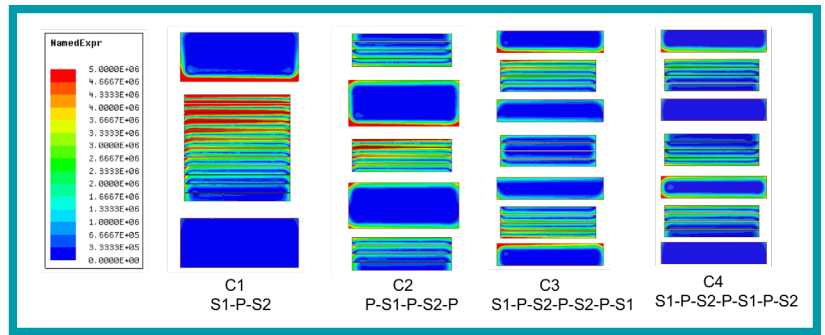

Figure 5

Table 1

1 Amp of Primary Load	
Conf#	Total Loss @ 100KHZ (W)
1	0.83
2	0.34
3	0.14
4	0.27

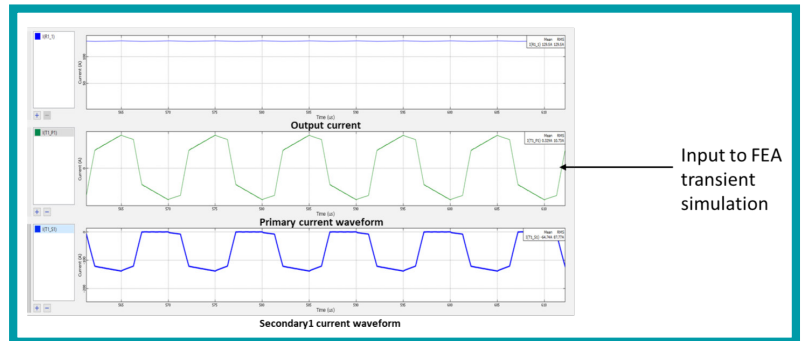

Figure 6

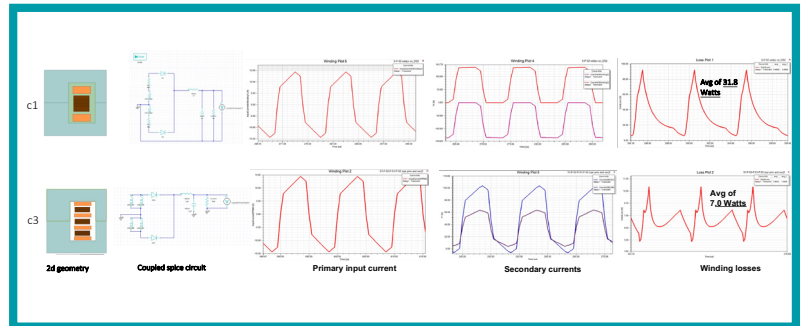

Figure 7

Output Inductor Design

As shown in figure 7, the transient simulation results quantify the improvement more accurately, and it can be easily seen by calculating the average value of the winding loss that design C4 will have a loss of 4 times less than C1. This is a tremendous improvement in the development of this part which would not be possible without smart utilization of FEA software, we will now see how using a similar approach the output inductor can also be quickly designed and optimized.

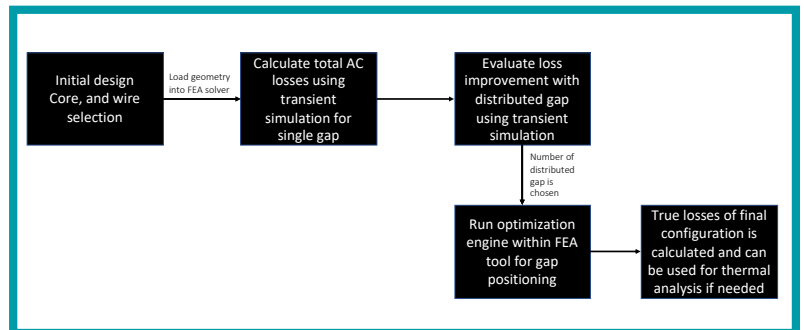

Figure 8

For high current inductors, traditional methods for calculating AC losses in the windings will work better than they do in planar transformer with vertically stacked windings. However, when it comes to accurately predicting the additional loss generated due to fringing flux from the core gap then more sophisticated tools must be used. Furthermore, finding the optimal number of gaps in order to reduce fringing AC losses and at what positions they need to be placed requires the use of an iterative optimization engine. As a result, the following design methodology is proposed for the output inductor:

Similarly, to the approach taken for the isolation transformer, a first design iteration of the output is worked out based on traditional magnetic design equations to calculate the required core gap length and cross section. Because this inductor will carry a significant magnitude of DC bias, it is important for the winding DC resistance to be low, and therefore, a wide copper flat coil will be used.

The iteration 1 design is simulated using a 2D axisymmetric approximation using the eddy current solver at 100kHz, and the AC loss for a 1 amp of load is extracted. It is then easy to modify the model geometry and rerun the analysis for 2,3,4 and 5 gaps to evaluate further improvements. In the chart showed in Figure 10 below it can be seen that going from one gap to two gaps cuts the AC loss in half, and that the loss savings are small beyond four gaps. Based on the results it is chosen to move forward with four distributed gaps, but the question of how far away from each other the gaps need to be located remains. For this purpose, a small optimization exercise is performed. The model is then tweaked so that the distance between gaps is defined as a variable that can be changed by the solver, and the optimization engine goal is then set to minimize AC loss. The results of this exercise find that for a center post with 4 gaps, the minimum AC loss is obtain when the gaps are placed at 3.3 mm from each other.

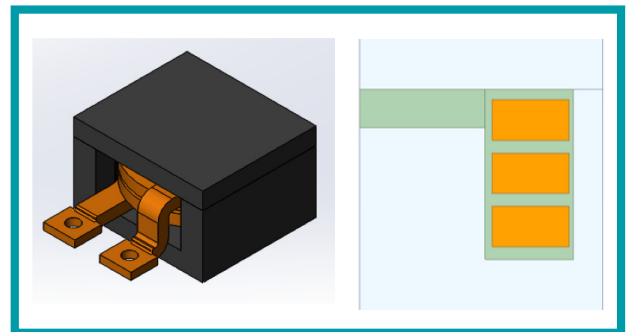

Figure 9

Finally, the last step is to confirm the validity of this design method by calculating the true loss of the inductor when working in the power converter. Therefore, a transient simulation is set and the current load applied is extracted from a circuit simulation of the converter performed in ETA designer. Two cases are ran, single gap vs 4 distributed gaps placed 3.3 mm from each other. It is calculated that the total loss of the single gapped inductor will be 11.5W, the optimized inductor loss is calculated at 6.8W, this is a 60% improvement.

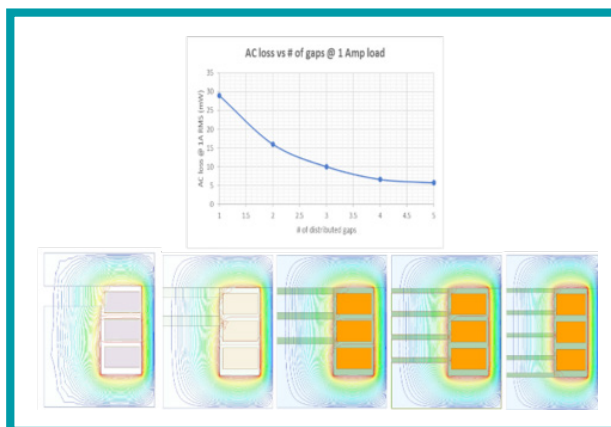

Figure 10



Figure 11

Conclusion

We have demonstrated how designers can take full advantage of the capabilities of advance electromagnetic FEA software to quickly model complicated planar magnetics and improve their performance. The 2D eddy current solver was used for quickly comparing winding topologies in the power transformer, and AC losses in distributed gap configurations for the output inductor. Even though the solver did not produce the true loss, it did help to identify the best configuration. Also, the transient solver was used for more accurate loss calculation due to its ability to specify any current waveform. In addition to presenting the capabilities of these two solvers, we showed how the optimization engine can be used to identify the most suitable gap positioning in an inductor design.

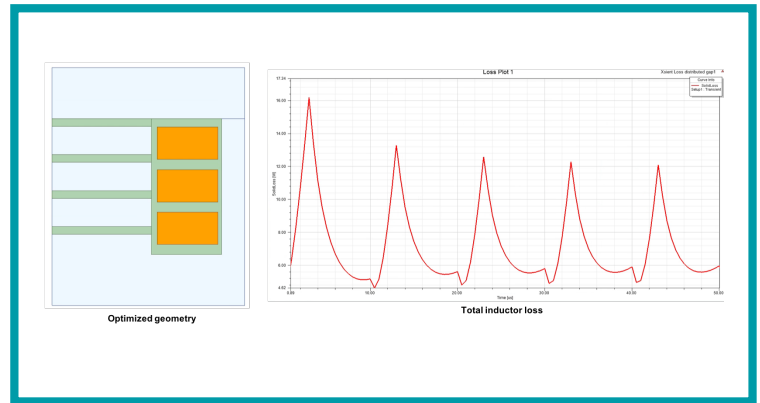

Figure 12

References

- [1] Texas Instruments: Phase Shifted Full Bridge DC/DC Power Converter Design, 2014
- [2] Ansys: Introduction to Ansys Maxwell 17.0, 2016

Written By: David Mungia

Written By: Gerard Healy