

# The Use of Surge Protective Devices in Mitigating the Effects of Lightning on the Natural Gas Pipeline Infrastructure

James Schroeder P.E., Schroeder Consulting Services  
Fred Czubba, Phoenix Contact USA

## Executive Summary

This paper will review the use and implementation of surge protective devices (SPDs) in mitigating and controlling the effects of conducted electromagnetic interference (EMI) due to lightning strikes on the natural gas pipeline infrastructure. The paper will focus on the proper use of SPDs for the following application areas:

- Cathodic protection systems
- Process transmitters
- Inductive coupling issues associated with lightning strikes to electrical transmission equipment and the resultant radiated and conducted damage to pipelines located in the same right-of-way space

## TABLE OF CONTENTS

Executive Summary .....	1
Introduction .....	2
Cathodic Protection Systems .....	3-4
The Use of SPDs in Flange Breakdown Applications .....	5
Process Transmitters .....	5-6
Shared System ROW Inductive Coupling Issues .....	6-7
Conclusion .....	8
References .....	8

**Introduction**

The natural gas pipeline infrastructure, including transmission lines, distribution lines, processing plants, compressions stations, gate stations, and underground storage facilities, is susceptible to lightning strikes. This infrastructure encompasses approximately 310,000 miles of natural gas transmission pipeline, 1.9 million miles of natural gas distribution pipelines<sup>1</sup>, approximately 3,000 compression stations, and the associated electronic supervisory control and data acquisition (SCADA) systems used to control the infrastructure. This vast size provides a high probability that there will be lightning strikes on or near the natural gas infrastructure on a recurring basis.

In addition to the substantial size of the present U.S. pipeline infrastructure, it is estimated that the combined global growth of the pipeline infrastructure under construction or in the planning cycle for 2012 will be 118,000 miles. The two major areas of growth are the Asia Pacific Region, (34,295 miles) and the North America Region (31, 951 miles).<sup>2</sup>

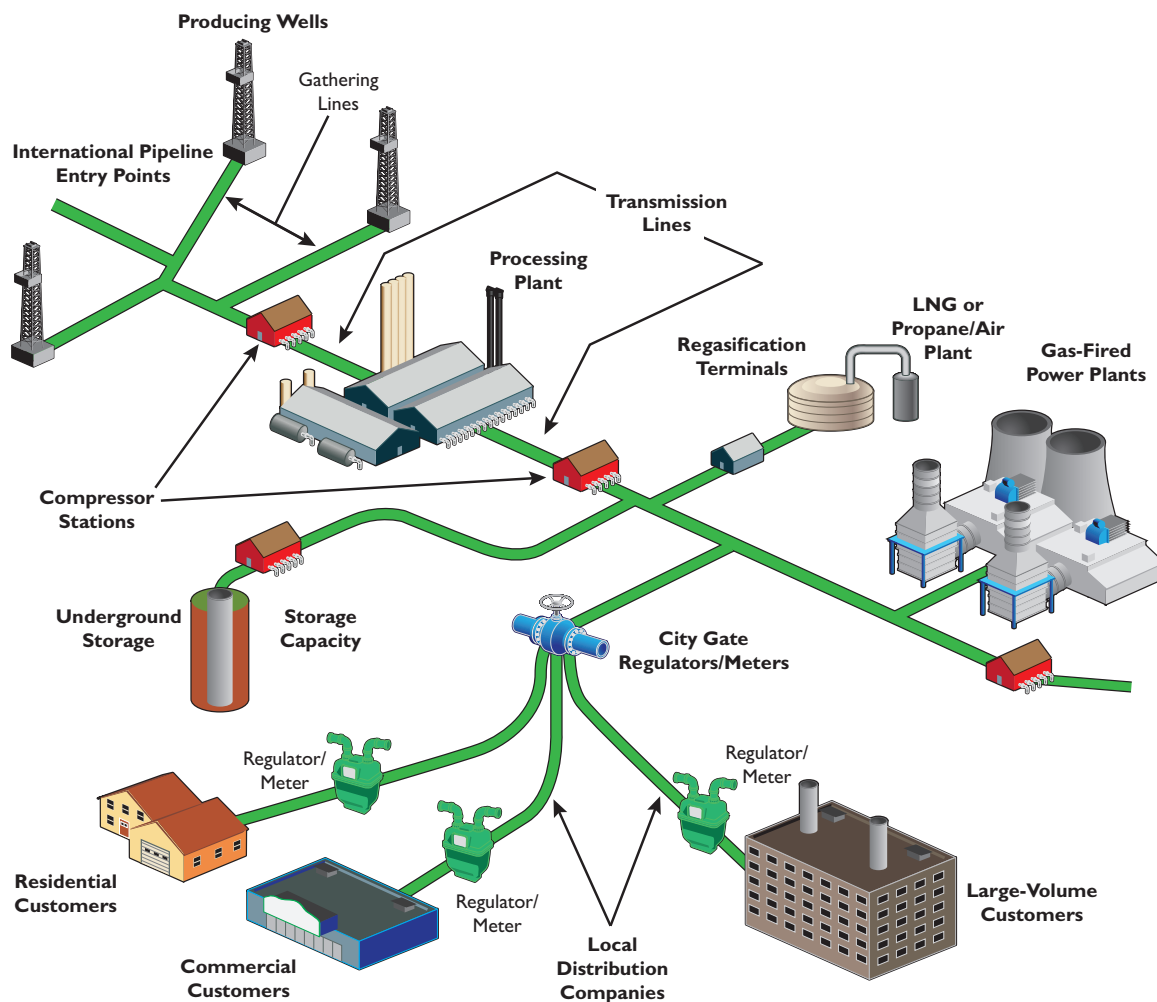

**Figure 1** Natural gas pipeline system

## Cathodic Protection Systems

The transmission lines and distribution lines associated with the natural gas pipeline infrastructure are made of steel and are subject to corrosion. The two main methods used to lessen and mitigate the effects of corrosion are specialty coatings and cathodic protection.<sup>3</sup>

The available types and application methods of specialty coatings is beyond the scope of this paper. Suffice to say that all transmission lines are coated with long-term (10 years or more) coating materials to inhibit the effects of corrosion.

There are two types of cathodic protection systems in use today for the natural gas pipeline infrastructure: the galvanic protection (sacrificial) system and the impressed current cathodic protection system (ICCP).

Both of these systems require four components to work:

1. An anode: made of copper or magnesium for sacrificial systems, and silicon-cast iron, mixed metal oxide, graphite, platinum or titanium-coated alloys for ICCP systems
2. A cathode: the protected pipeline
3. An electrolyte: for underground pipeline, this would be the earth
4. A connecting wire: to complete the circuit.

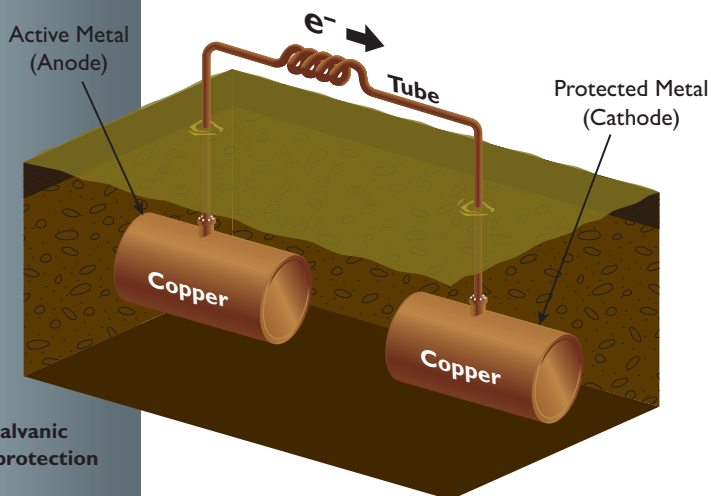

**Figure 2 – Galvanic (sacrificial) protection schematic**

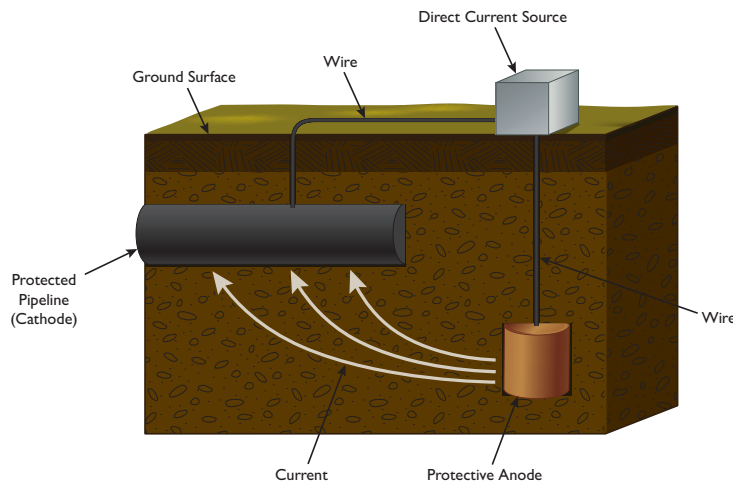

**Figure 3 Impressed Current System**

The galvanic system depends on the resistance of the electrolyte (the earth) to establish the amount of current flow between the cathode (pipeline) and the anode (magnesium or copper rods placed in relatively close proximity of the pipeline). The anode rods are sacrificial and need to be replaced on a periodic basis. Changes in the earth's resistance (due to soil type and moisture content variations) will result in changes in current flow between the anode and cathode. This variability of current flow as a function of soil resistance is the main uncontrolled variable of the galvanic system. The galvanic system is primarily used in the distribution segment of the pipeline infrastructure. This is due to smaller pipe diameter, shorter run lengths, lower current requirements, and the presence of foreign metallic structures. A typical protection span for a galvanic system is six to ten miles.

The ICCP system adds an external DC power supply to stabilize and increase the required current flow of the system (Figure 3).

The DC power supply used in the ICCP system provides a higher, stabilized and adjustable current flow for the system. This allows a longer protection span for the ICCP system. ICCP systems are primarily used for the transmission segment of the pipeline infrastructure. ICCP systems typically span 30 to 40 miles. The

**CATHODIC PROTECTION SYSTEMS continued >>**

**CATHODIC PROTECTION SYSTEMS** *continued* »

anodes of the ICCP system may be silicon-cast iron (most economical), mixed metal oxide, graphite, platinum or titanium-coated alloys.<sup>4</sup> The main concern of the impressed current system is that too high of an impressed current can damage the pipe coating or drive current to other structures not intended to receive current.

Use of either of these systems as a corrosion resistance measure requires that the supply pipes being protected are electrically isolated from the system's ground. Therefore, when underground supply pipes surface at compression stations, measurement and regulation stations, gate stations, etc., an insulating flange insert separates the electrically isolated pipe (transmission or distribution lines) from the electrically grounded pipe of the station.

**Figure 4** shows a cross section of a typical flange insert with sealing element.

The typical flange insert used to separate station pipe from isolated CP pipe is a 1/8-inch-thick phenolic retainer containing a precision tapered groove to accommodate the controlled compression of a sealing element.<sup>5</sup> The phenolic retainer has a dielectric breakdown voltage of 500 volts per mil. Therefore, the dielectric breakdown voltage from isolated pipe to system pipe through the retainer wall would be  $500 \text{ v/m} \times 125 \text{ mil} = 62,500 \text{ volts}$ .

By comparison, the dielectric breakdown voltage of air under standard conditions (20°C and 20% R. H.) is generally accepted to be  $3 \times 10^6 \text{ volts/meter}$  or 76 volts/mil. Therefore, the dielectric breakdown voltage of the air immediately above the flange between the isolated pipe and the system pipe would be  $76 \text{ v/m} \times 125 \text{ m} = 9,500 \text{ volts}$ .

During direct or nearby lightning strikes in the vicinity of the supply pipeline, strong earth currents and voltage gradients are developed in the adjacent soil. These gradients result in voltage potential differences of several thousand volts across the supply pipeline. This high-voltage gradient wave travels along the pipeline

until the pipeline surfaces at a compression station, transmission station or gate station. At that point, the voltage wave meets a flange isolation interface. Here, due to voltage differences between the isolated section and the grounded section on the other side of the isolation flange, the air immediately above the flange could be ionized or the voltage differential could be sufficient to puncture the dielectric of the flange interface. Either result would lead to arcing and potential igniting of any natural gas in the area. Surge protective devices (SPDs) can prevent such events from happening by limiting the voltage across the flange interface to an acceptable level.

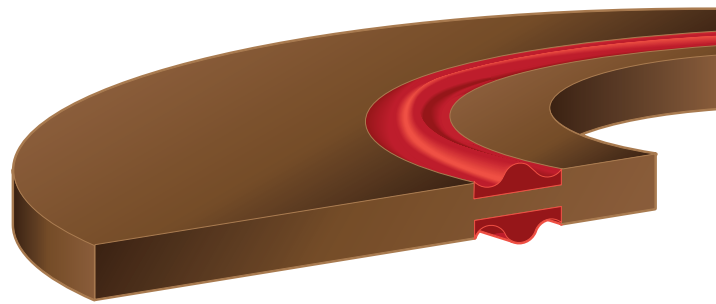

**Figure 4** Typical flange insert

## The Use of SPDs in Flange Breakdown Applications

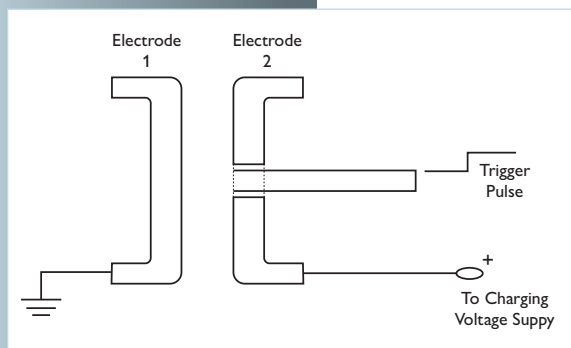

**Figure 5** Triggered spark gap

SPDs are electronic devices that switch to a low impedance mode at a predetermined voltage level. They enter a low-voltage, high-current mode after reaching their triggering voltage. In the situation described above, the SPD will act to limit the voltage gradient that has developed

across the isolated flange to a value below either the dielectric breakdown of air or the dielectric breakdown of the flange insert.

A controlled triggered spark gap (**Figure 5**) is one of the SPD configurations that can be used for this application.

The triggering voltage for the spark gap is typically set at approximately 1000 V, well below the breakdown voltage of air or the breakdown voltage of the flange dielectric. When the transient voltage gradient amplitude reaches approximately 1000 V, the spark gap begins to conduct. This equalizes the voltages on both sides of the flange and maintains the integrity of the flange interface and the surrounding air dielectric.

**Figure 6** shows an example of a triggered spark gap SPD protecting an isolated pipeline flange.

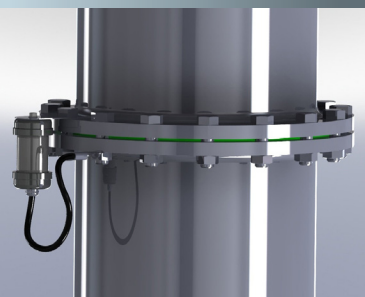

**Figure 6** Isolated flange spark gap protection scheme

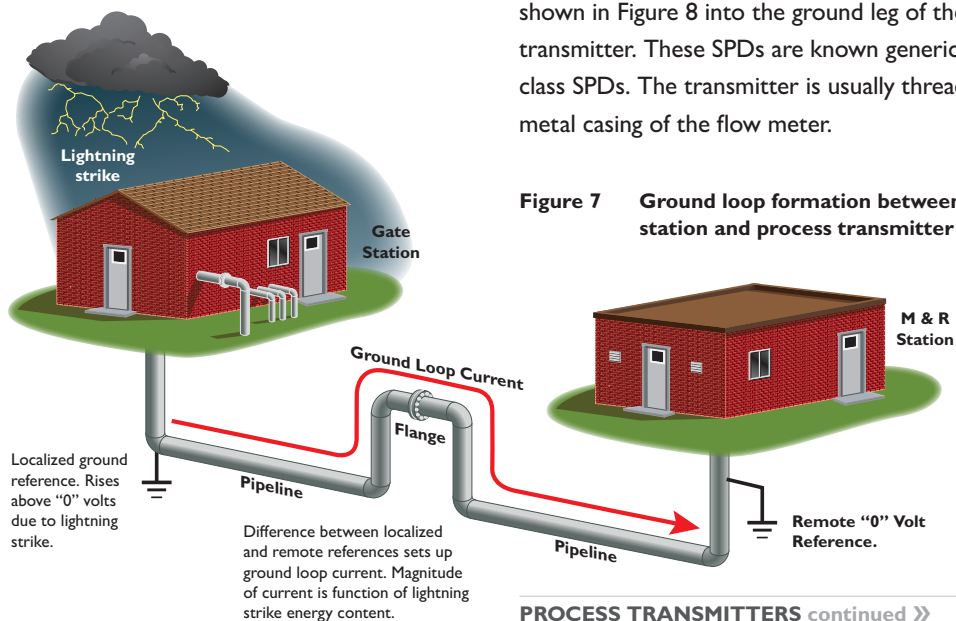

**Figure 7** Ground loop formation between control station and process transmitter

## Process Transmitters

Process transmitters are a part of the electronic supervisory control and data acquisition (SCADA) system used to control the pipeline infrastructure. Process transmitters are found in measurement equipment such as flow meters and are usually located remotely from control stations.<sup>6</sup> SPDs are used to protect the electrical integrity of process transmitters in one of two ways.

A process transmitter used to measure data as part of the flow meter process center can be locally grounded at the site. This localized grounding of the transmitter will result in the formation of ground loops if a high-voltage transient (lightning strike) occurs at or near the locally grounded control station (**Figure 7**).

A lightning strike at or near the control center will increase the ground voltage potential at the control center relative to the localized ground voltage at the process transmitter by several thousand volts, depending upon the amplitude and duration of the lightning strike. This imbalance in ground potential between the control center and the process center will cause a transient surge current in the earth (ground current) to flow, creating what is known as a ground loop. This ground current will flow into the process transmitter and cause transmitter failure. To avoid transmitter failure, insert an SPD such as the one shown in **Figure 8** into the ground leg of the process transmitter. These SPDs are known generically as TP-48 class SPDs. The transmitter is usually threaded into the metal casing of the flow meter.

PROCESS TRANSMITTERS continued >>



**Figure 8** TP 48 Surge Protective Device

#### PROCESS TRANSMITTERS *continued* »

There are reasons not to ground the process transmitter used to measure data as part of the flow meter process center. One reason is to provide mechanical isolation from the piping, which can be the actual source of the surge fault current traveling along the pipe. Another is the prevention of the ground loop scenario caused by multiple ground references. Whatever the reason, implementing a TP-48 SPD in the reference leg of the transmitter can protect the electrical integrity of the floating transmitter. This will serve to limit the surge voltage between the transmitter and system ground to a manageable level and preserve the functionality of the transmitter.

#### Shared System ROW Inductive Coupling Issues

Distribution natural gas pipelines often use the same right-of-way (ROW) as other utilities, usually electrical power distribution utilities. This minimizes the amount of land required for utilities in a given locality. The proximity of different utilities in the same ROW can cause unexpected and serious problems for natural gas pipelines when lightning strikes the electrical distribution utility (**Figure 9**).

As illustrated in **Figure 9**, buried pipelines in the vicinity of electrical distribution systems are susceptible to inductively coupled transients and parasitic ground currents as a result of lightning strikes to the nearby electrical transmission lines. The amount of damage sustained by the pipeline due to the lightning strike is a function of the magnitude and duration of the strike's energy level at the point of contact with the electrical distribution system. While calculating the resultant energy coupling into the gas pipeline is complex

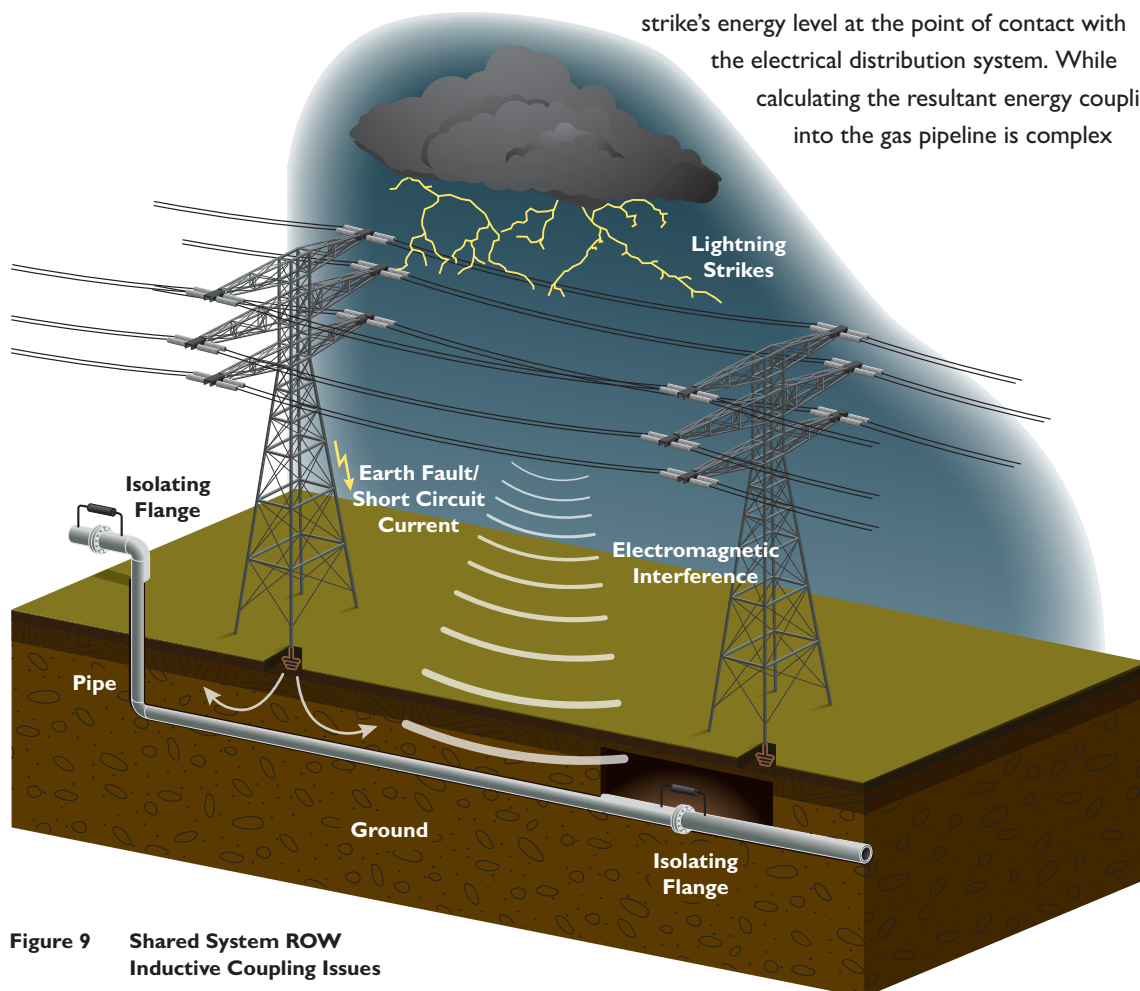

**Figure 9** Shared System ROW Inductive Coupling Issues

SHARED SYSTEM ROW *continued* »

**SHARED SYSTEM ROW** *continued* >>

and beyond the scope of this paper, it can be said that the energy level that is coupled into the pipeline infrastructure will vary inversely with the distance from the strike's contact point.<sup>7</sup> Therefore, maximizing the distance between the electrical utility structure and the pipeline within the constraints of the ROW dimensions will serve to minimize the amount of energy coupled into the pipeline.

Damage from past incidents due to the coupling mechanisms described above has included damaged electrical conduit and cabling, destroyed flange guards, damaged grounding cables and pipeline exterior, damaged turbine meters and pressure controllers.<sup>8</sup> The following SPD measures can mitigate future damage to above-ground or buried pipeline due to lightning strikes under similar conditions:

- Install SPDs across all isolated flanges, above and below ground, in the proximity of ROW electrical distribution towers. These SPDs (**Figure 10**) should have 100,000-amp surge current ratings due to the possibility of extremely high current faults associated with the potential loss of phase voltages in the electrical system due to a lightning strike and the cascading effect on the natural gas distribution infrastructure.
- Install SPDs at power line input feeds to gate stations, M/R stations, etc., that are in proximity of electrical grid transmission equipment within an electrical utility ROW. Again, these SPDs should have 100,000 A surge current ratings due to the possibility of extremely high current faults associated with the potential loss of phase voltages in the electrical system due to a lightning strike and the cascading effect on the natural gas distribution infrastructure. **Figure 11** shows this type of installation.

Implementing these measures in conjunction with industry-recommended grounding and corrosion resistance methodologies will substantially mitigate pipeline damage during lightning strikes to utilities in ROW environments.

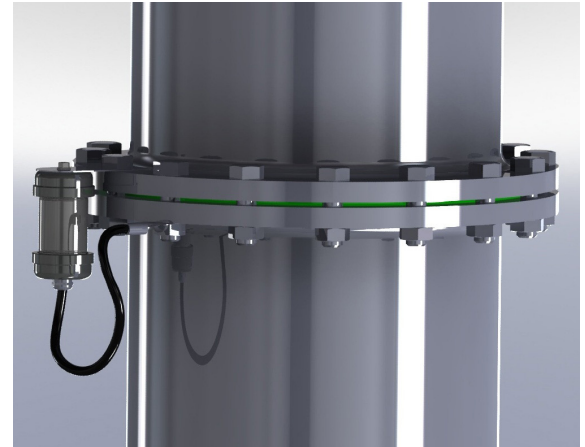

**Figure 10** 100 kA SPD for use on isolated flange ROW applications



**Figure 11** 100 kA SPD for use at power line input feeds

## Conclusion

This paper has discussed the implementation and usage of SPDs for the protection of the transmission and distribution of natural gas pipeline infrastructure against damage created by lightning strikes. Specifically the paper has focused on the following areas of concern related to the pipeline infrastructure:

- Cathodic protection systems
- Process transmitters
- Inductive coupling issues associated with lightning strikes to electrical transmission equipment and the resultant radiated and conducted damage to pipelines located in the same right-of-way space.

By understanding the principles discussed here and implementing the recommendations, it is possible to mitigate future potential pipeline damage related to lightning strikes. Indeed, an investment in strategically placed SPDs in critical use areas could return a significant savings in future cost of unmitigated damages.

## References

1. *Pipeline and Gas Journal*; May 2012; Pg. 56 – US Department of Transportation's Office of Pipeline Safety.
2. *Pipeline & Gas Journal*; January 2012; "2012 Worldwide Pipeline Construction Report," Pg. 26.
3. 71st Annual Appalachian Gas Measurement Short Course 2011, "Corrosion Control Considerations for M&R Stations," Michael J. Placzek, P.E., Duke Energy Gas Transmission.
4. "Cathodic Protection" – a knol by Adam Junid: <http://knol.google.com/k/cathodic-protection>
5. *Pipeline Seal & Insulator, Inc., Linebacker Flange Isolation Kits Catalog*, Pg. 7.
6. *Emerson Process Management, Model 1700 and 2700 Field and Integral Mount Transmitter*.
7. *The Lightning Discharge*, Martin A. Uman, 2001. Chapter 7 , Pg. 111.
8. 71st Annual Appalachian Gas Measurement Short Course 2011, "Grounding Techniques at Plants and Gate Stations," Pg. 314, Donald R. Long, ISTA, Inc., and Matthew G. Esmacher, P.E., Washington Gas.

### ABOUT PHOENIX CONTACT

Phoenix Contact develops and manufactures industrial electrical and electronic technology products that power, protect, connect and automate systems and equipment for a wide range of industries. Phoenix Contact GmbH & Co. KG, Blomberg, Germany, operates 50 international subsidiaries, including Phoenix Contact USA in Middletown, Pa.

For more information about Phoenix Contact or its products, visit [www.phoenixcontact.com](http://www.phoenixcontact.com), call technical service at 800-322-3225, or e-mail [info@phoenixcon.com](mailto:info@phoenixcon.com).