

CHARX PS-M2/825DC/1000DC/ 30KW

Power module



Data sheet
110335_en_00

© PHOENIX CONTACT 2022-03-25

1 Description

CHARX power, which includes power modules, is an integral part of a device family for professional solutions for operating DC charging infrastructure.

The power module was designed especially for the fast charging of electric vehicles. The modular concept enables the performance-based scaling of charging points in the 19" control cabinet. Alternatively, operation in a local DC grid is also possible.

DC charging is supported with high DC voltages and DC currents up to High Power Charging (HPC).

Features

- Digitally controlled power level
- Electrical isolation between DC input voltage and DC output voltage
- >95% efficiency at 50% load supply
- Freely scalable with a nominal power of up to 360 kW
- Low power dissipation in standby mode
- CAN bus communication with the controller, e.g., a CHARX control controller
- Management of 30 power modules as CAN bus devices within one CHARX control controller
- High power density at just 3RU (134 mm)
- Can be mounted and operated in any location
- Approved in accordance with IEC 61851-1

Technical data (short form)

Input voltage range	650 V DC ... 825 V DC
Nominal output voltage	150 V DC ... 1000 V DC
Output current range	0 A ... 100 A
Nominal power	30 kW
Degree of efficiency	> 95 % (P _{Out} >50%)
Ambient temperature (operation)	-40 °C ... 70 °C
Dimensions W/H/D	483 mm / 134 mm / 550 mm
Rack unit	3 U
Weight	30 kg



All technical specifications are nominal and refer to a room temperature of 25 °C and 70% relative humidity at 100 m above sea level.

2 Table of contents

1 Description 1

2 Table of contents 2

3 Ordering data 5

4 Technical data 6

5 Safety and installation notes 10

6 Design 11

 6.1 Rating plate 11

 6.2 Device connections and functional elements 12

 6.2.1 Front view 12

 6.2.2 Rear view 12

 6.3 Block diagram 12

 6.4 Device dimensions 13

 6.4.1 Front view 13

 6.4.2 Side view 13

 6.4.3 Top view 14

7 Mounting/remove 15

 7.1 Installation location 15

 7.1.1 19" control cabinet 15

 7.1.2 DC home charger 15

 7.2 Fan unit flow direction 15

 7.3 Installation height 15

 7.4 Mounting the power module 16

 7.4.1 Mounting in a 19" control cabinet 16

 7.4.2 Mounting in a DC home charger 16

 7.5 Removing the power module 17

 7.5.1 Removing from a 19" control cabinet 17

 7.5.2 Removing from a DC home charger 17

8 Device connection terminal blocks 18

 8.1 DC input terminal 18

 8.2 Primary side connection and fuse protection 18

 8.2.1 DC supply network 18

 8.2.2 Connecting connection terminal blocks DC IN +/-/PE 18

 8.2.3 Removing connection terminal blocks DC IN +/-/PE 19

 8.3 DC output terminal blocks 19

 8.4 Secondary-side connection and fuse protection 19

 8.4.1 Connecting connection terminal blocks DC OUT +/- 20

 8.4.2 Removing connection terminal blocks DC OUT +/- 20

 8.5 Can bus connection jacks (RJ45) 21

 8.5.1 CAN bus topology 21

 8.5.2 Connecting/removing CAN bus lines 21

 8.5.3 CAN bus interface RJ45 contact assignment 21

9	Function elements	22
9.1	LED status indicators	22
9.1.1	Operation	22
9.1.2	Alarm	22
9.1.3	Malfunction	22
9.2	DIP switch	23
9.2.1	Default group number	23
9.3	Fan unit	23
10	Manually assigning the group number	23
10.1	Addressing examples.....	23
10.1.1	Addressing example 1	23
10.1.2	Addressing example 2	23
11	Protective functions (device-internal and external)	24
11.1	Alarm message triggers.....	24
11.1.1	DC UVP/OVP (Undervoltage/overvoltage protection)	24
11.1.2	OTP (Overtemperature protection)	24
11.1.3	Internal bus voltages	24
11.1.4	CAN bus communication	24
11.2	Malfunction message triggers	24
11.2.1	DC OVP (Overvoltage protection)	24
11.2.2	DC OCP (Overcurrent protection)	24
11.2.3	Internal address conflict and internal bus error.....	24
11.2.4	Fan unit	24
12	Output power	25
12.1	Increasing power	25
12.1.1	Parallel operation	25
12.1.2	Fundamental prerequisites for parallel operation (power increase).....	25
13	Derating	25
13.1	Ambient temperature.....	25
13.2	Output power.....	25
13.3	Installation height	26
13.4	Position-dependent derating	26
14	Disposal and recycling	26
15	Attachment	27
15.1	Application example with EV-PLCC-AC1-DC1 DC charging controller (1624130)	27
15.2	CAN bus communication cable connection	27
15.3	Downloading PC WORX StartUpPackage.....	27
15.4	Unzipping and installing the PC WORX StartUpPackage	28
15.4.1	Step 1: Unzip StartUpPackage.....	28
15.4.2	Step 2: Start project	28
15.4.3	Step 3: Select the target directory	28

15.5	Step 4: Create a library	28
15.5.1	Step 5: Project tree in PC WORX	28
15.5.2	Step 6: Select a CAN* instance	29
15.5.3	Step 7: Replace input variables	29
15.5.4	Step 8: IP address of the charging controller	29
15.5.5	Step 9: Generate a program code	30
15.5.6	Step 10: Power module starts to operate	30

3 Ordering data

Description	Type	Item no.	Pcs./Pkt.
CHARX power, Fast charging module for setting up DC charging stations, 19" rack mounting, CAN bus, output: 150 V DC...1000 V DC / 0 A...100 A	CHARX PS-M2/825DC/1000DC/30KW	1296467	1
Documentation	Type	Item No.	Pcs./Pkt.
CAN-based communication protocol between one or more power modules and a charging controller	DB EN CHARX PS-M2/... CAN BUS GCP Protocol V1.1 0	-	-
Accessories	Type	Item no.	Pcs./Pkt.
Network cable, degree of protection: IP20, cable length: 2 m, number of positions: 8, CAT6, cable outlet: straight, Ethernet	VS-IP20-OE-94F-LI/2,0	1415255	1
Network cable, degree of protection: IP20, cable length: 2 m, number of positions: 8, CAT6, cable outlet: straight, Ethernet	VS-IP20-OE-94F-LI/2,0	1415255	1
Programmable charging controller for DC and AC charging of electric vehicles in accordance with IEC 61851-1,-23, DIN SPEC 70121, and CHAdeMO, with integrated cellular modem	EV-PLCC-AC1-DC1	1624130	1



You will find the latest accessories for the item at phoenixcontact.net/products.

4 Technical data

Input data

Input voltage range	650 V DC ... 825 V DC
Nominal input voltage range	650 V DC ... 825 V DC
Current consumption	48 A (650 V DC) / 38 A (825 V DC)
Inrush current limitation	< 60 A
Insulation resistance	> 10 MΩ
Overvoltage category	II (IEC 60664-1)

Electric strength of the insulation

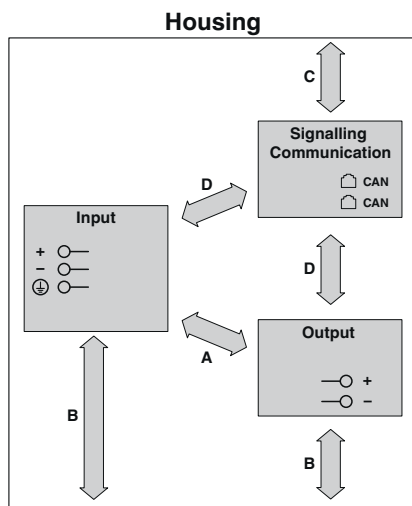

	Insulation distance	Insulation voltage
Insulation voltage input/output	A	2121 V DC
Insulation voltage input, output / housing	B	2121 V DC
Insulation voltage signal, communication/housing	C	707 V DC
Insulation voltage input, output/signal, communication	D	4242 V DC

Connection data: Input

	Connection capacity Terminal block	recommended
Connection method	Push-in connection	
Stripping length	18 mm (rigid/flexible)	
1-conductor rigid	1.5 mm ² ... 16 mm ²	10 mm ²
1-conductor flexible	1.5 mm ² ... 16 mm ²	10 mm ²
1-conductor rigid (AWG) (Cu)	15 ... 5	7

Output data		
Output voltage range	150 V DC ... 1000 V DC	
Protection against overvoltage at the output (OVP)	> 1040 V DC	
Output current range	0 A ... 100 A	
Control deviation	< 0.5 % (Voltage deviation static load change 20% ... 100%) < 1 % (Current deviation Static load change 20 % ... 100 %) ± 0.2 % (Input voltage change ±20 %)	
Switch-on delay	< 8 s	
Overshoot behavior	± 3 % (Switch-on procedure)	
Connection data: Output	Connection capacity Terminal block	recommended
Connection method	T-LOX knee lever connection	
Stripping length	18 mm (rigid/flexible)	
1-conductor rigid	10 mm ² ... 50 mm ²	25 mm ²
1-conductor flexible	16 mm ² ... 50 mm ²	25 mm ²
1-conductor rigid (AWG) (Cu)	8 ... 0	16
Data interface		
Interface	CAN bus	
Number of interfaces	1	
Connection method	2x RJ45 (pin assignment, CANopen standard)	
Locking	Locking clip	
Transmission physics	Twisted-Pair	
Topology	Line (daisy-chain connection)	
Termination resistor	120 Ω (Terminating the end device)	
Transmission speed	125 kbps	
Transmission length	max. 20 m	
Electrical isolation	yes (primary/secondary) no (PE)	
Supported protocols	CAN 2.0B	

General data

Degree of protection	IP20
Protection class	I
Internal fan	✓
Volumetric flow	

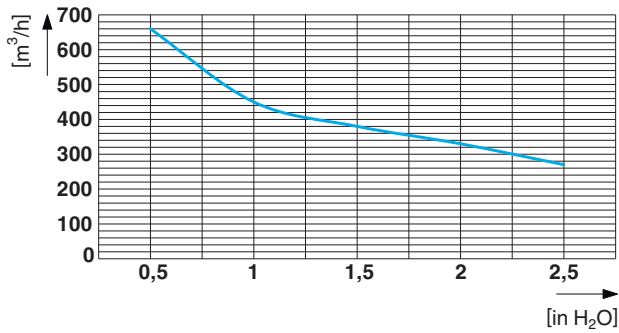

Flow direction	from front to back
Noise level	< 60 dB (1 m)
Mounting type	19" rack mounting
Dimensions (W/H/D)	483 x 134 x 550 mm
Rack unit	3 U
Weight	30 kg

Power consumption

Nominal power	30 kW
Efficiency	> 95 % (P _{Out} >50%)
Power dissipation standby	< 14 W

Ambient conditions

Degree of pollution	2
Ambient temperature (operation)	-40 °C ... 70 °C
Derating	> 45 °C ... 55 °C (1.2 A/K) > 55 °C (3.2 A/K) > 55 °C (1 kW/K)
Overtemperature protection (OTP)	> 75 °C
Ambient temperature (storage/transport)	-40 °C ... 70 °C
Max. permissible relative humidity (operation)	≤ 95 % (non-condensing)
Installation height	≤ 4000 m (Derating >2000 m: 10% / 1000 m)
Noise level	< 60 dB (1 m)

Standards/specifications

Electric vehicle conductive charging system - Part 1:
General requirements IEC 61851-1

Conductive charging systems for electric vehicles –
Part 23: DC supply equipment for electric vehicles IEC 61851-23

EMC data

Interference emission Class B (IEC 61000-6-3)

Noise immunity IEC 61000-6-1

5 Safety and installation notes

Symbols used

Instructions and possible hazards are indicated by corresponding symbols in this document.



This is the safety alert symbol. It is used to alert you to potential personal injury hazards. Obey all safety measures that follow this symbol to avoid possible personal injuries.

There are different categories of personal injury that are indicated by a signal word.



WARNING

This indicates a hazardous situation which, if not avoided, could result in death or serious injury.



CAUTION

This indicates a hazardous situation which, if not avoided, could result in minor or moderate injury.

The following symbols are used to indicate potential damage, malfunctions, or more detailed sources of information.



NOTE

Together with the signal word NOTE and the accompanying text, this symbol alerts readers to a situation that may cause damage or malfunction to the power module, surrounding property, or hardware/software.



This symbol and the accompanying text provide the reader with additional information or refer to detailed sources of information.

Safety notes and warning instructions



WARNING: Danger to life by electric shock!

- Only qualified specialist personnel may install, commission, and operate the power module.
- Never carry out work when voltage is present.
- Establish connection correctly and ensure protection against electric shock.
- Cover termination area after installation in order to avoid accidental contact with live parts (e. g., installation in control cabinet).
- Protection may be impaired if the power module is used in a manner not specified by the manufacturer.



NOTE

- Observe the national safety and accident prevention regulations.
- Assembly and electrical installation must correspond to the state of the art.
- The power module is a built-in device and is designed for mounting in a control cabinet.
- The IP20 degree of protection of the device is intended for use in a clean and dry environment.
- Observe mechanical and thermal limits.
- Connect the protective conductor device terminal block (PE) with ground.
- Ensure that the primary-side wiring and secondary-side wiring are the correct size and have sufficient fuse protection.
- The connection parameters for wiring the power module, such as the required stripping length with and without ferrule, are listed in the section: Technical data.
- To wire the input and output terminals on the device side, use double insulated cables with a test voltage >1000 V DC.
- Use copper cables for operating temperatures of >75 °C (ambient temperature <55 °C)
>90 °C (ambient temperature <75 °C).
- The power module is approved for connection to a DC power grid with protective conductor connection and a supply voltage of maximum 825 V DC.

- Protect the device against foreign bodies penetrating it, e.g., paper clips or metal parts.
- The power module is maintenance-free. Repairs may only be carried out by the manufacturer. Opening the housing invalidates the warranty.
- The power module may only be used for its intended use.
- The power module is a built-in device and is designed for horizontal mounting in a 19" control cabinet.
- The 19" control cabinet must be securely anchored to the base surface and sufficiently protected against tipping over.
- The high intrinsic weight of the power module requires two side-mounted high-load support rails in the 19" control cabinet.
- Power modules must be assembled in the 19" control cabinet in the specified sequence from bottom to top. They are removed in reverse order.

6 Design

6.1 Rating plate

In accordance with the German Product Safety Law (ProdSG) it is only permissible to make such products available on the market if they meet certain safety standards. It must be ensured at all times that users are not exposed to hazards.

In accordance with ProdSG, the power module must therefore be fitted with a rating plate. All relevant information on the safe use of the power module must also be included.



The device rating plate for the power module is located on the right-hand side of the housing (as viewed from the front).

Figure 1 Rating plate information

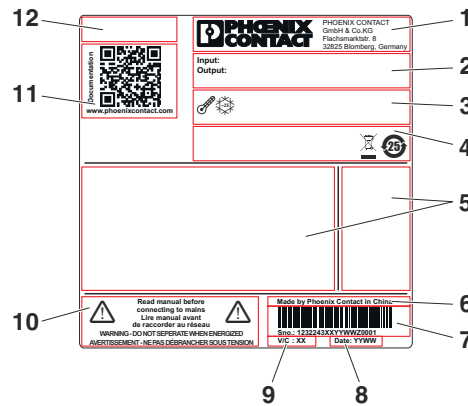

Key

No.	Designation
1	Identification of the provider
2	Device connection data
3	Ambient conditions
4	Disposal and recycling notes
5	Device approvals/conformities
6	Phoenix Contact Group production facilities
7	Bar code and serial number for identification
8	Date of manufacture
9	Version designation
10	Designation of product-related device documentation
11	QR code as web link to the device documentation
12	Product designation

6.2 Device connections and functional elements

Device connections are labeled with connection tags to ensure clear and definitive identification.

The connection tags are split into the following connection levels:

Connection level	Marking
DC supply voltage	DC IN: +/-/PE⊕
DC output voltage	DC OUT: + / -
2x CAN bus communication interface	CAN

6.2.1 Front view

Figure 2 Position of the function and operating elements

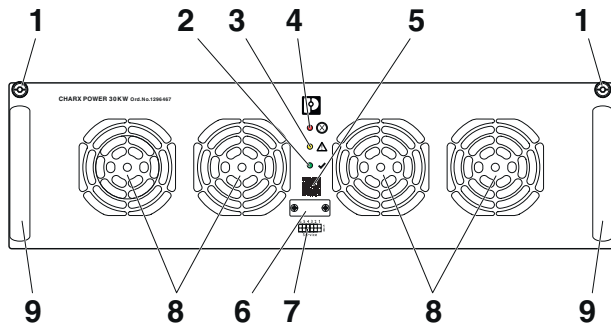

Key

No.	Designation
1	Mounting screws for 19" control cabinet mounting
2	Power module in operation: LED display (green)
3	Power module in alarm state: LED display (yellow)
4	Power module in malfunction state: LED (red)
5	QR code web link
6	DIP switches for manually assigning a group number (behind the cover)
7	Marking field for the manually assigned group number
8	Fan unit (speed-controlled)
9	Handle for mounting/removing the power module

6.2.2 Rear view

Figure 3 Position of the function elements

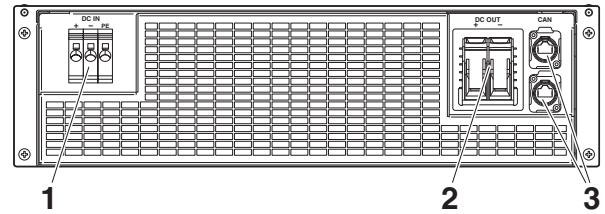

Key

No.	Designation
1	DC feed-in terminals with protective conductor connection PE (supply voltage)
2	DC output terminal blocks
3	2x CAN bus communication interface

6.3 Block diagram

Figure 4 Block diagram (schematic diagram)

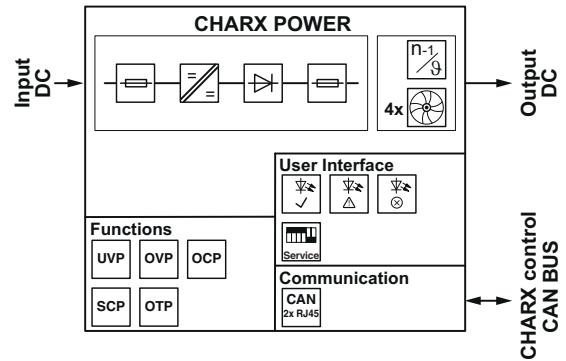

6.4 Device dimensions

6.4.1 Front view

Figure 5 Device dimensions (dimensions in mm)

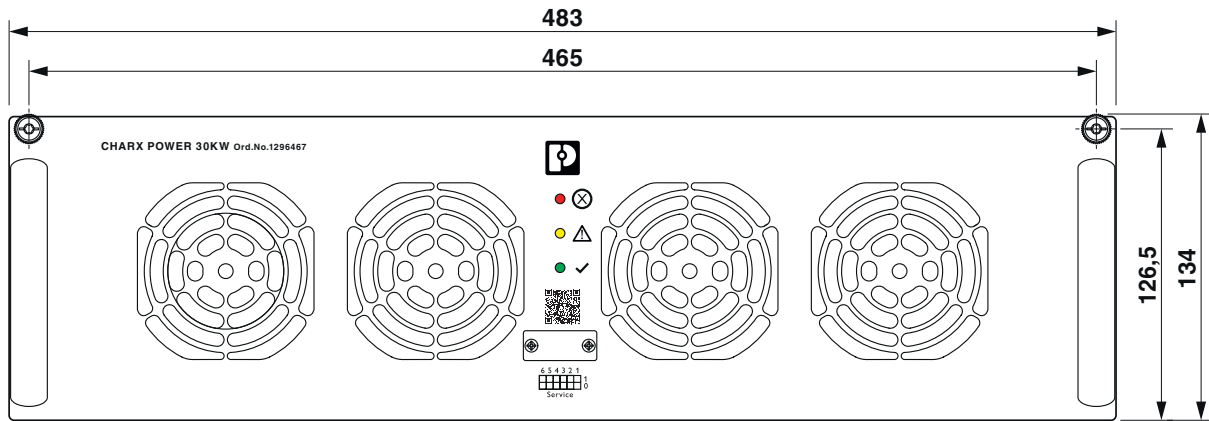

6.4.2 Side view

Figure 6 Device dimensions (dimensions in mm)

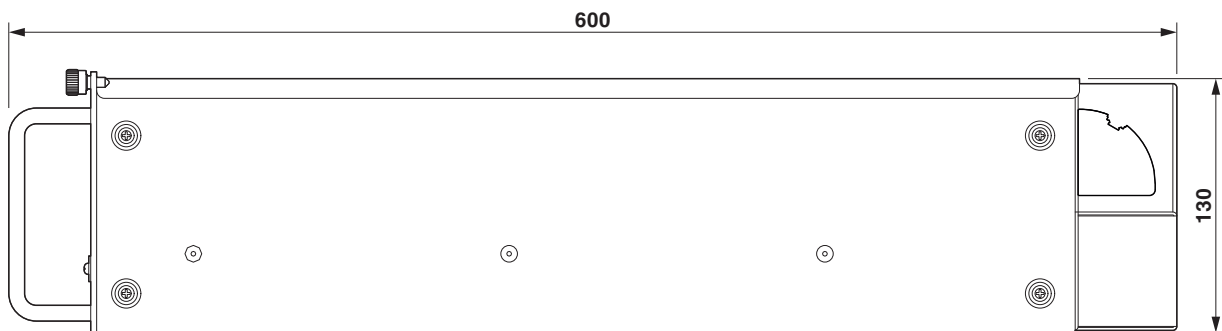

6.4.3 Top view

Figure 7 Device dimensions (dimensions in mm)

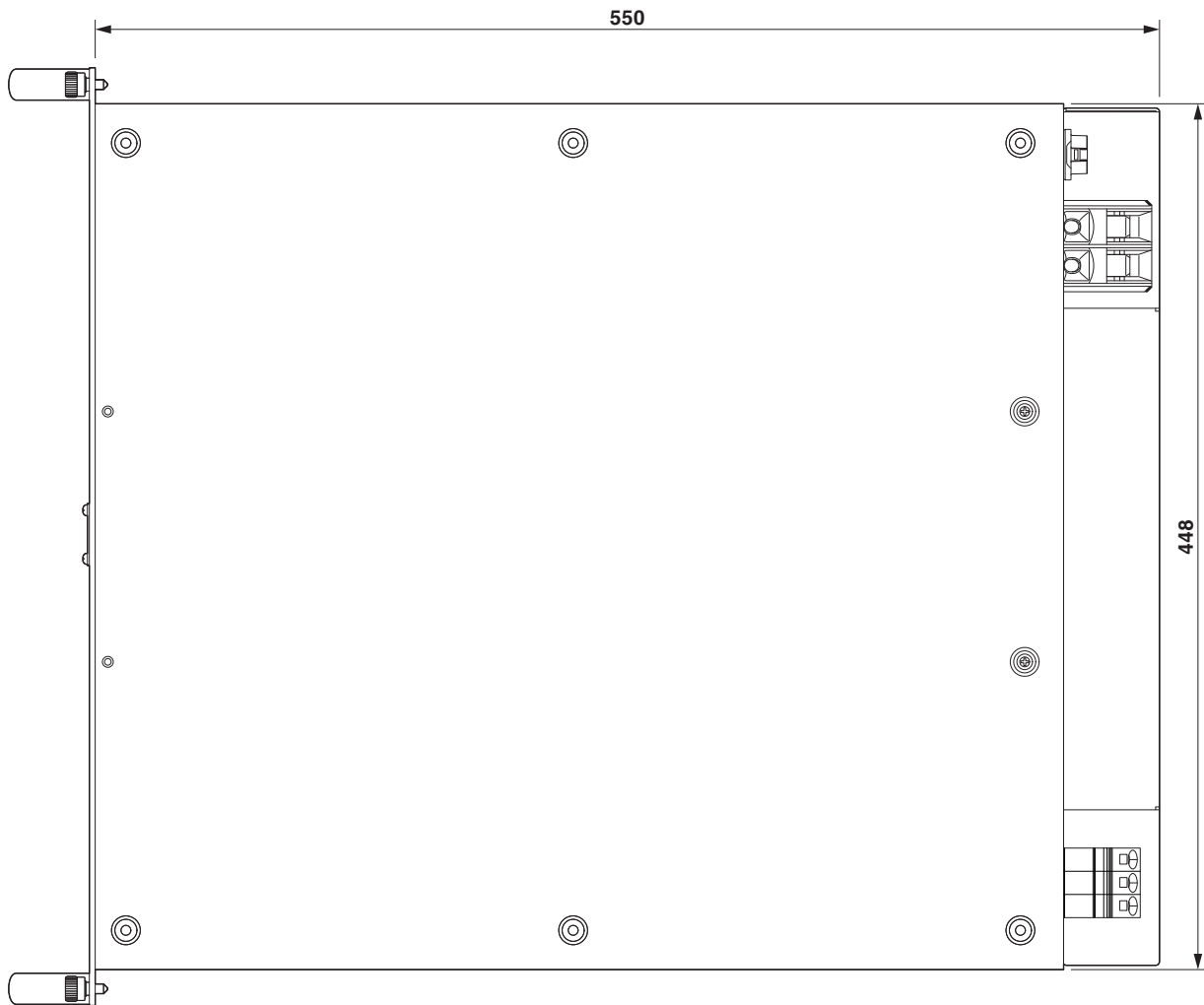

7 Mounting/remove

7.1 Installation location

Select a suitable installation location for erecting the DC charging infrastructure. Two mounting versions are available, depending on the nominal power required.

7.1.1 19" control cabinet

The power module is designed to be mounted and operated horizontally in a 19" control cabinet. Two mounting screws integrated into the front panel are used to attach the power module.

In a 19" control cabinet, twelve power modules can be scaled for a charging point with up to 360 kW of total power.



WARNING: Danger due to heavy weight

Ensure that the 19" control cabinet is installed securely and that it is not subject to tensile loads. Use sufficient and suitable mounting material to securely fix the 19" control cabinet in place.

Figure 8 Power modules mounted in the 19" control cabinet (schematic diagram)

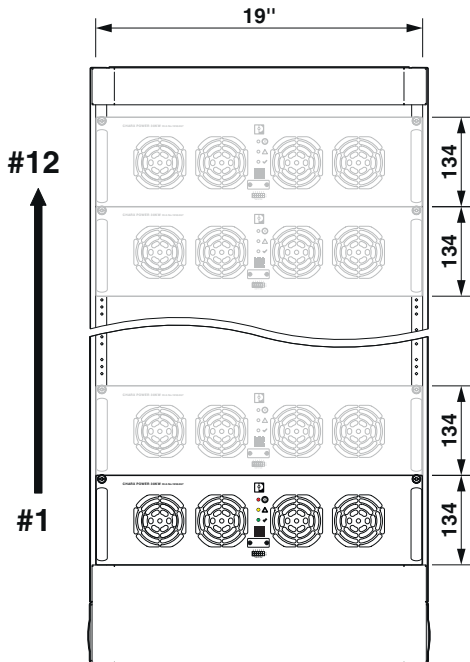

7.1.2 DC home charger

Operation of the power module in a DC home charging station, for example, is also possible as an alternative to the 19" control cabinet installation.

The preferred position for installing the power module is based on the available space



The power module can be mounted and operated in any location.



NOTE: Avoid overheating

Ensure sufficient space at the installation location. The device-side ventilation grid on the power module may not be obstructed by neighboring equipment. Otherwise, despite active cooling, there is a DANGER that trapped heat will lead to the power module switching off.

7.2 Fan unit flow direction

The power module is equipped with an internal fan unit for active cooling of the device-internal power levels. The inflow for the ambient air for air cooling is through the device front and the outflow is through the device rear.

For the volumetric flow required for cooling for each power module, please refer to section: Technical data.

Figure 9 Flow direction (schematic diagram)

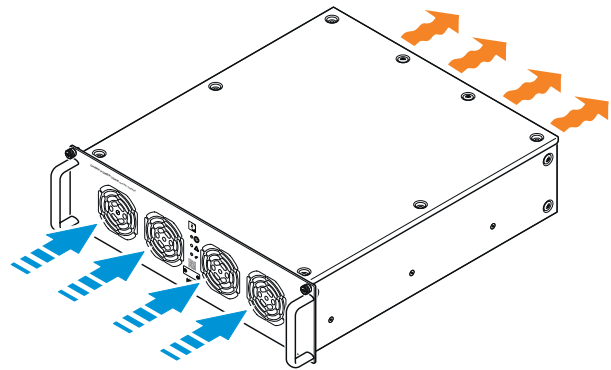

7.3 Installation height

You can operate the power module without power limitations up to an installation altitude of 2000 m. For altitudes higher than 2000 m, different specifications apply due to the differing air pressure and the reduced air cooling associated with this (see section: Derating).

7.4 Mounting the power module



Due to the high intrinsic weight of the power module, a second person should always help when mounting the power module in the 19" mounting frame and when removing it.



Two side-mounted high-load support rails are necessary to ensure that the high intrinsic weight of the power module is safely supported in the 19" mounting frame.



WARNING: Danger of tipping due to center of gravity offset

Power modules must be assembled in the 19" mounting frame in the specified sequence from bottom to top. They are removed in reverse order.



WARNING: Observe the national safety regulations for working on electrical systems

In Germany, this work may only be carried out by electrically skilled persons with additional training.

Furthermore, the five basic safety rules apply:

- Disconnect safely
- Ensure power cannot be switched on again
- Verify safe isolation from the supply for all positions
- Ground and short circuit
- Cover or safeguard adjacent live parts

7.4.1 Mounting in a 19" control cabinet

To mount the power module in a 19" control cabinet, proceed as follows:

1. Ensure that the necessary side-mounted support rails have been installed at the required installation pitch (3RU) in the mounting frame.
2. Place the power module in its normal mounting orientation on the side-mounting support rails in the 19" mounting frame. When doing so, ensure that the power module sits securely on at least 1/3 of the housing depth.
3. Then carefully push the power module into the 19" mounting frame without tilting it. Ensure that the two mounting screws on the front panel protrude into the opening of the cage nuts in the 19" mounting frame.
4. Next, tighten the mounting screws using a suitable screwdriver. The front panel of the power module must lie flush on the 19" mounting frame.
5. Check that the power module is firmly and securely positioned in the 19" mounting frame.

6. Connect the electrical DC connecting cables and the CAN bus communication (see section: Device connection terminals).

Figure 10 Mounting in a 19" control cabinet

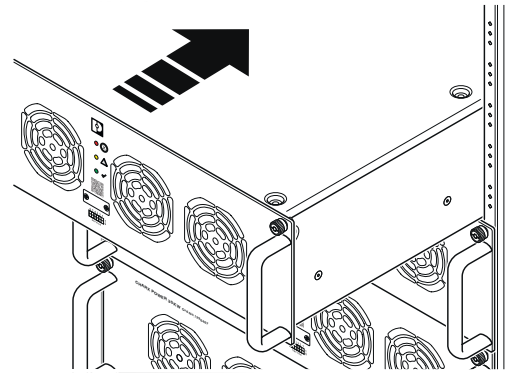
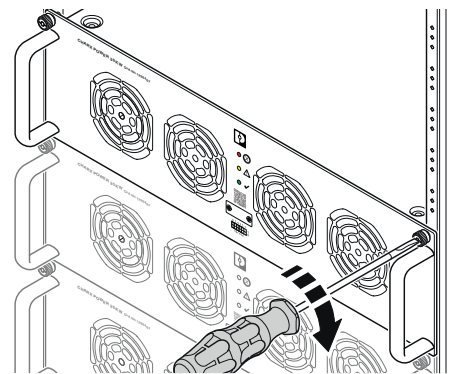

Figure 11 Fixing the power module securely in place



7.4.2 Mounting in a DC home charger

An individual mounting bracket is necessary for installing the power module in a DC home charger. The bracket selected depends on the available installation space.

7.5 Removing the power module



Due to the high intrinsic weight of the power module, a second person should always help when mounting the power module in the 19" mounting frame and when removing it.



WARNING: Observe the national safety regulations for working on electrical systems

In Germany, this work may only be carried out by electrically skilled persons with additional training.

Furthermore, the five basic safety rules apply:

- Disconnect safely
- Ensure power cannot be switched on again
- Verify safe isolation from the supply for all positions
- Ground and short circuit
- Cover or safeguard adjacent live parts

7.5.1 Removing from a 19" control cabinet

To remove the power module from a 19" control cabinet, proceed as follows:

1. Ensure that the power module is disconnected from all power sources.
2. Begin with the preparatory work at the rear of the power module.
3. Disconnect the electrical DC connecting cables (DC IN) from the power module. Secure the uninsulated connecting cables using suitable insulating clamps.
4. Disconnect the electrical DC connecting cables (DC OUT) from the power module. Secure the uninsulated connecting cables using suitable insulating clamps.
5. Disconnect the CAB bus communication from the power module.
6. Continue with the preparatory work on the front of the power module.
7. With a suitable screwdriver, completely unscrew the two mounting screws on the front panel out of the cage nuts on the 19" mounting frame.
8. Next, use the two handles to carefully pull the power module 2/3 of the way out of the 19" mounting frame. When doing so, ensure that the power module does not tilt downwards.

9. Remove the power module and carefully put it down on a secure surface.

Figure 12 Removing from a 19" control cabinet

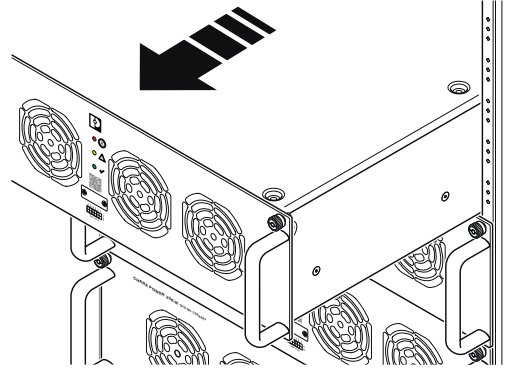

7.5.2 Removing from a DC home charger

To remove the power module from a DC home charger, proceed as follows:

1. Ensure that the power module is disconnected from all power sources.
2. Begin with the preparatory work at the rear of the power module.
3. Disconnect the electrical DC connecting cables (DC IN) from the power module. Secure the uninsulated connecting cables using suitable insulating clamps.
4. Disconnect the electrical DC connecting cables (DC OUT) from the power module. Secure the uninsulated connecting cables using suitable insulating clamps.
5. Disconnect the CAB bus communication from the power module.
6. Continue with the preparatory work on the front of the power module.
7. With a suitable screwdriver, completely unscrew the two mounting screws on the front panel out of the mounting bracket.
8. Now use the two handles to lift the power module carefully out of the mounting bracket.
9. Put the removed power module down carefully on a secure surface.

8 Device connection terminal blocks

The connection terminal blocks of the DC feed-in, DC load supply, and CAN bus communication are located at the rear of the power module.

 For the necessary connection parameters for the connection terminal blocks, refer to the technical data section.

8.1 DC input terminal

The power module is operated on a DC grid with protective conductor connection. The primary-side DC connection is via connection terminal blocks DC IN +/-/PE.

No additional tools are necessary for wiring the primary side connection terminal blocks.

 The power module is approved for connection to a DC power grid with protective conductor connection and a maximum supply voltage of 825 V DC.

Figure 13 Position of the DC IN connection terminal blocks (detail section)



8.2 Primary side connection and fuse protection

The power module must be installed in accordance with the provisions in EN 61851-1. It must be possible to switch the power module off using a suitable disconnection device from the outside. The line protection on the primary side, for example, is suitable for doing so (see section: Technical data).

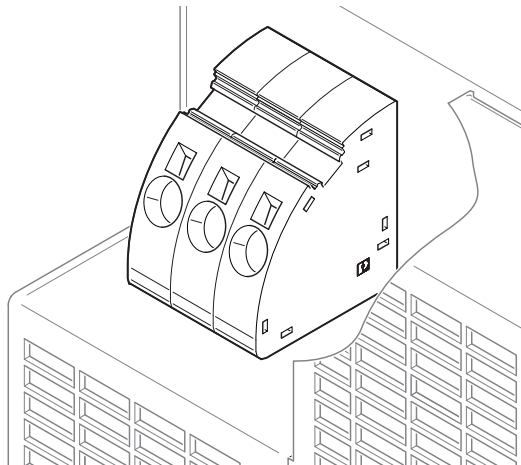
8.2.1 DC supply network



DANGER: Hazardous voltage

When operating the power module on a DC supply network, observe the maximum permissible line voltage (see section: Technical data).

Figure 14 Schematic diagram, two-phase fuse protection

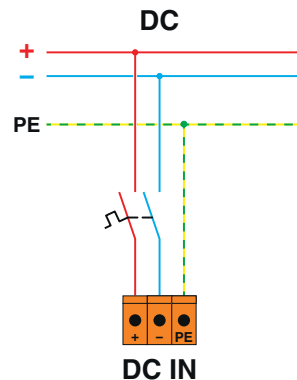

8.2.2 Connecting connection terminal blocks DC IN +/-/PE

To wire the power module with the feeding connecting cables, proceed as follows:

1. Strip the individual connecting cables and, if necessary, fit the conductor ends with ferrules (see section: Technical data)
2. Guide the stripped ends of the connecting cables into the center of the round cable openings in the connection terminal blocks until they stop.
3. Then check that the connecting cables are fixed securely in the connection terminal blocks.



If you use rigid connecting cables or flexible connecting cables with ferrules to wire the power module, no additional tools are required. Simply plug the connecting cables into the terminal openings provided.



NOTE: Observe mechanical loads

Avoid any mechanical loads on the connecting cables, otherwise the electrical contact is at risk. Make sure there is enough space for the wiring in the wiring space.



DANGER: Life-threatening mains voltage

Only perform wiring work on the DC feed-in terminals when no voltage is present. The protective conductor of the feed-in system must be connected to the ground terminal PE on the power module. Operating the power module without a protective conductor connection is not permitted.

Figure 15 Connecting the connecting cable

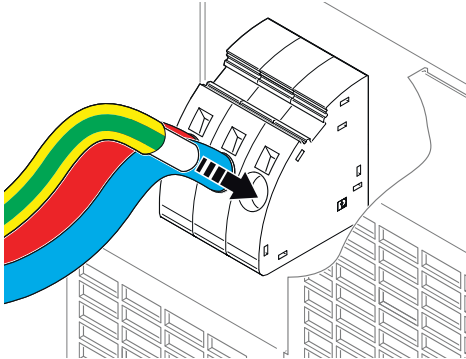

8.2.3 Removing connection terminal blocks DC IN +/- /PE

To remove the feeding connecting cables from the power module, proceed as follows:

1. Ensure that the power module is disconnected from all power sources.
2. To open the connection terminal blocks, insert a screwdriver into the square opening. Then carefully push the screwdriver to release the connection terminal block.
3. Pull the connecting cables from the connection terminal blocks. Secure the uninsulated ends of the connecting cables using suitable insulating clamps.

Figure 16 Removing connecting cables

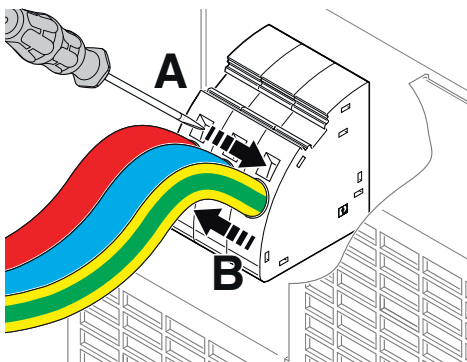

8.3 DC output terminal blocks

The power module features a digitally controlled power level and provides electrical energy to the DC OUT+/- connection terminal blocks.

Using a screwdriver as a locking lever is helpful when wiring the DC connection terminal blocks.



The DC output voltage is electrically isolated from the feeding DC input voltage.

8.4 Secondary-side connection and fuse protection

Connect the DC load to be supplied to the DC OUT connection terminal blocks in accordance with EN 61851-1.

Figure 17 Position of the DC OUT connection terminal blocks (detail section)

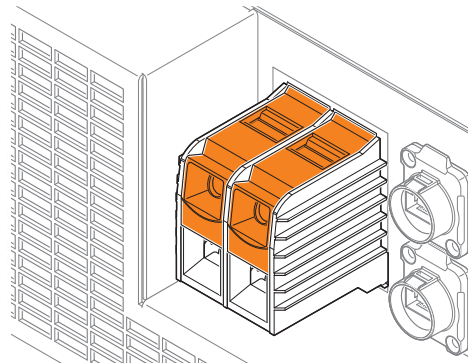

The power module has one connection terminal block with positive potential and one with negative potential for supplying the DC load. The power module is electronically short-circuit-proof and idling-proof. In the event of a fault, the output voltage is limited.



DANGER: Hazardous voltage

2-position fuse protection is necessary for the positive and negative potentials.

Figure 18 Wiring principle, 2-position fuse protection

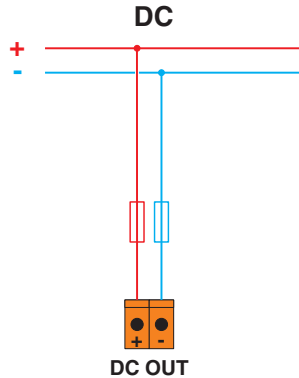

8.4.1 Connecting connection terminal blocks DC OUT+/-

To wire the power module to the DC load that is to be supplied, proceed as follows:

1. Strip the individual connecting cables and, if necessary, fit the conductor ends with ferrules (see section: Technical data)
2. To open the respective connection terminal blocks, insert a screwdriver into the round opening on the cover flap. Now pry the screwdriver upwards.
3. Guide the stripped ends of the connecting cables into the open connection terminal blocks until they stop.
4. To contact the connecting cables in the connection terminal blocks, pry the relevant cover flaps back down.
5. Check to make sure that the cover flap has been completely pried down to the stop. If not, a seamless electrical connection is not guaranteed.

NOTE: Observe mechanical loads
 Avoid any mechanical loads on the connecting cables, otherwise the electrical contact is at risk. Make sure there is enough space for the wiring in the wiring space.

DANGER: Life-threatening DC voltage
 Only perform wiring work on the DC connection terminal blocks when the power module is disconnected from all power sources.

Figure 19 Connecting the DC connecting cable

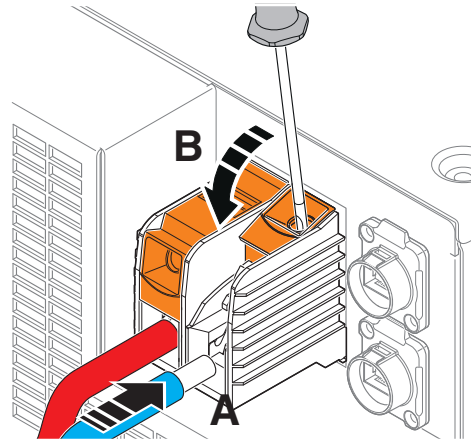

8.4.2 Removing connection terminal blocks DC OUT+/-

To remove the connecting cables of the power module from the DC load that is to be supplied, proceed as follows:

1. Ensure that the power module is disconnected from all power sources.
2. To open the respective connection terminal blocks, insert a screwdriver into the round opening on the cover flap. Now pry the screwdriver upwards.
3. Lift the stripped ends of the connecting cables out of the open connection terminal blocks. Secure the uninsulated ends of the connecting cables using suitable insulating clamps.

Figure 20 Removing connecting cables

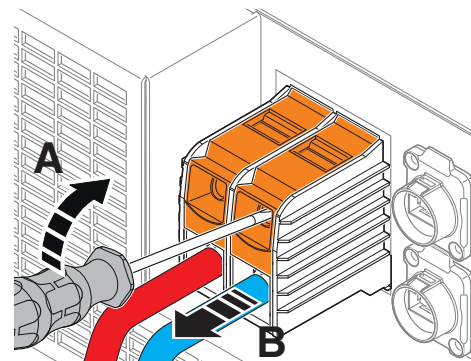

8.5 Can bus connection jacks (RJ45)

The power module is equipped with two CAN bus interfaces for communication with a higher-level CHARX control controller (CAN bus master).

Figure 21 Position of the CAN bus communication interfaces (detail section)

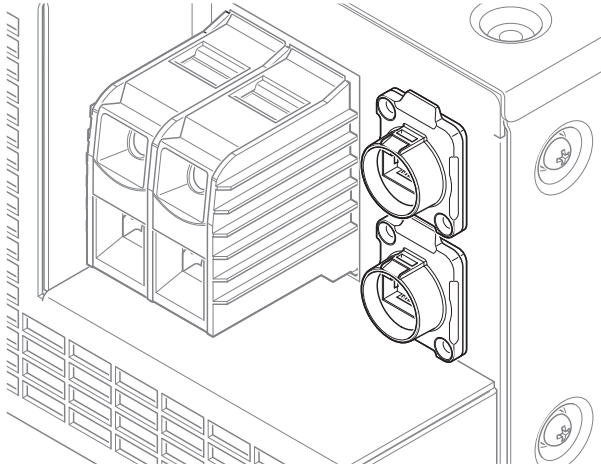

8.5.1 CAN bus topology

The power module supports the CAN 2.0B protocol. The maximum number on a linear CAN bus is 30 power modules.

CAN bus communication between the higher-level CHARX control controller and the power module is realized as a daisy-chain connection with an RJ45 connection.

Use CAT 3, CAT 4, or CAT 5 cables with RJ45 connection plugs as CAN bus lines. The functional assignment of the CAN bus communication (CAN-IN, CAN-OUT) has not been specified on the power module.

i When cabling the CAN bus communication interfaces, uniform assignment of the RJ45 jacks will simplify troubleshooting in the event of errors. This can be, for example: CAN-IN (lower RJ45 jack), CAN-OUT (upper RJ45 jack)

i The end devices on the maximum 20 m long CAN bus are each terminated with a 120 Ω termination resistor.

Figure 22 CAN bus communication as a daisy-chain connection (schematic diagram)

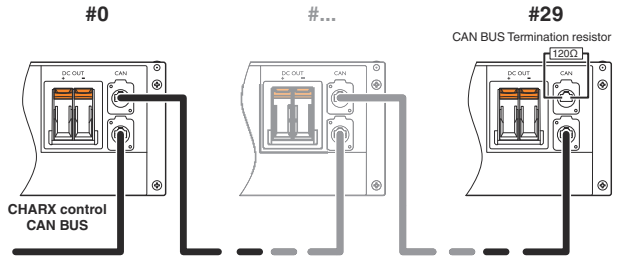

8.5.2 Connecting/removing CAN bus lines

The CAN bus line is connected in exactly the same way as a standard network cable. When you plug the bus line RJ45 connection plug into the RJ45 jack on the power module, you will hear the typical click when it locks into place.

To unlock it, press the unlocking lever on the RJ45 connection plug and pull the plug out of the RJ45 jack.

8.5.3 CAN bus interface RJ45 contact assignment

Pin	Signal	Description
1	CAN_H	CAN_H signal (active high)
2	CAN_L	CAN_L signal (active low)
3	—	not used
4	—	not used
5	—	not used
6	—	not used
7	—	not used
8	—	not used

Figure 23 CAN bus interface pin assignment

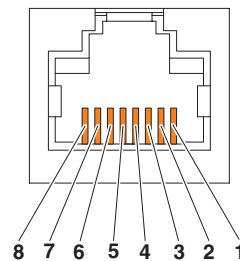

i The controller CAN_GND must be connected to functional ground (FE) to ensure interference-free data transmission between the power module and the superordinate controller.

9 Function elements

The functional elements of the power module are located on the front of the housing and are categorized as follows:

- LED status indicators
- DIP switch

The functional elements also include a row of internal fans for active cooling of the power levels.

Figure 24 LED status indicators (detail section)

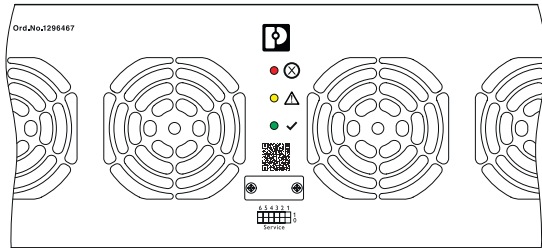

9.1 LED status indicators

Various LED status indicators are available for preventive power module function monitoring. Various indicator modes provide information on the current device status of the power module.

9.1.1 Operation

 LED status indicator - operation

The possible indicator modes and their descriptions are listed in the following table:

Operation	Description
○	Primary-side DC supply voltage not present
●	Normal operation
★	Device-internal function monitoring active

○ = off, ● = on, ★ = flashing (green)

9.1.2 Alarm

 LED status indicator - alarm

The possible indicator modes and their descriptions are listed in the following table:

Alarm	Description
○	Normal operation
●	Primary-side under- or overvoltage
	Internal device temperature above limit value
	Internal bus voltages outside the limit values
★	CAN bus communication interrupted

○ = off, ● = on, ★ = flashing (yellow)

 For further information on the alarm messages, see section: Protective functions (device-internal and external)

9.1.3 Malfunction

 LED status indicator - malfunction

The possible indicator modes and their descriptions are listed in the following table:

Error	Description
○	Normal operation
●	Overvoltage at the DC output
	Output current limitation at the DC output
	Device-internal address conflict and bus error
★	Malfunction in the fan unit

○ = off, ● = on, ★ = flashing (red)

 For further information on the malfunction messages, see section: Protective functions (device-internal and external)

9.2 DIP switch



DIP switch

The power module (CAN bus device) is automatically assigned a unique module address for CAN bus communication with the higher-level CHARX control controller as the CAN bus master.

The maximum number of CAN bus devices is limited to 30 power modules.



The DIP switch is only intended for manually assigning a module number to the power module. To protect against manipulation, the DIP switch is located behind a cover.

9.2.1 Default group number

The power module is delivered with a default group number 0_{Bin} .

Figure 25 Default group number (detail section)

Addressing default state

Group No.: 0
DIP switch code: 000000 0 = OFF, 1 = ON

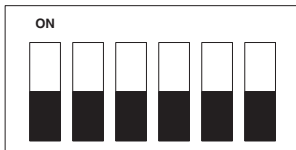

9.3 Fan unit

The power module is equipped with an internal fan unit for active cooling of the power levels. The power-dependent electrical heat that is generated during operation (self-heating) is dissipated to the ambient air via the heatsinks of the power levels. The prevalent ambient temperature at the installation location is acquired via temperature sensors. The fan controller regulates the speed via processors.

10 Manually assigning the group number

A group number can also be assigned to the power module using the 6-pos. DIP switch on the device side. The address range 1_{Bin} to 60_{Bin} is available for this purpose.



NOTE: Malfunction

A manual change of the group number cannot be carried out if the power module is active (DC load supply).

10.1 Addressing examples

The following addressing examples provide you with a general overview of the power module group number in binary code.



When addressing the power module manually, the assigned group number (in binary code) should be entered into the marking field for unique identification. Copy the DIP switch positions into the fields specified. The unique assignment of the power module simplifies any potential troubleshooting.

10.1.1 Addressing example 1

Figure 26 DIP switch (detail section)

Addressing example 1

Group No.: 3
DIP switch code: 000011 0 = OFF, 1 = ON

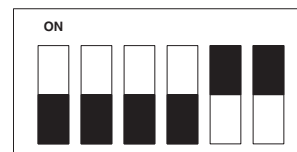

10.1.2 Addressing example 2

Figure 27 DIP switch (detail section)

Addressing example 2

Group No.: 60 (max. address range)
DIP switch code: 111000 0 = OFF, 1 = ON

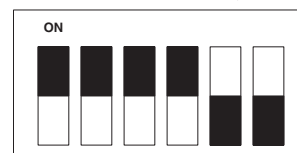

11 Protective functions (device-internal and external)

The power module supports various protective functions for device-internal protection and for protection of the connected DC load.

Depending on the type of protective function, it is possible to automatically return to normal operation once the cause of the malfunction has been remedied.

The following device-internal and external protective functions are executed and signaled as an alarm or malfunction message.

11.1 Alarm message triggers

Detection of the following events will trigger an alarm message. The alarm message is signaled with an LED status indicator (see section: LED status indicator - alarm).

11.1.1 DC UVP/OVP (Undervoltage/overvoltage protection)

The DC undervoltage/overvoltage protection function protects the DC input circuit of the power module against damage if the input voltage is too low or too high. If the DC input voltage leaves the permissible voltage range, the power module is switched off.

When the DC input voltage returns to the permissible voltage range, the power module switches back to normal operation. The DC output is enabled and the DC load supplied.

11.1.2 OTP (Overtemperature protection)

The overtemperature protection function protects the power module against damage in case of impermissibly high self-heating caused by electrical heat or external heating (e.g. due to solar irradiation). If the temperature limit value is exceeded, the DC output is switched off.

Once the power module has cooled down and the device-internal temperature falls below the triggering temperature limit value, the power module switches back to normal operation. The DC output is enabled and the DC load supplied.

11.1.3 Internal bus voltages

The bus module operates with different device-internal bus voltages. If impermissible deviations from the parameter limits are detected during cyclic checks, an alarm message is triggered.

11.1.4 CAN bus communication

The power module internally monitors whether CAN bus communication with the higher-level CHARX control controller is being executed. Irregularities in CAN bus communication trigger an alarm message.

11.2 Malfunction message triggers

Detection of the following malfunctions will trigger an alarm message. The malfunction message is signaled via an LED status indicator (see section: LED status indicator - malfunction).

11.2.1 DC OVP (Overvoltage protection)

The DC overvoltage protection function protects the DC output of the power module and the connected DC load against damage in the event of a device-internal overvoltage. The power module switches the DC output off.

When the DC output voltage returns to the permissible voltage range, the power module switches back to normal operation. The DC output is enabled and the DC load supplied.

11.2.2 DC OCP (Overcurrent protection)

The overcurrent protection function protects the DC output of the power module and the connected DC load against damage in the event of an impermissibly high current load. In addition, the DC output is short-circuit-proof. The power module switches the DC output off.

When the output-side current load drops back below the limit value, the power module switches to normal operation again. The DC output is enabled and the DC load supplied.

11.2.3 Internal address conflict and internal bus error

The power module performs cyclic checks for device-internal address conflicts and internal communication bus errors. If an internal bus communication interruption of >10 s is detected, an alarm message is triggered. If the internal bus communication returns within 10 to 20 s, the alarm message is reset. The power module returns to normal operation.

11.2.4 Fan unit

The power module checks cyclically that the device-internal fan unit is functioning correctly. If impermissible deviations from the parameter limits are detected during the device-internal check, an alarm message is triggered.

12 Output power

The output power provided by the power module when required depends on the state of charge of the connected DC load, e.g., a battery.

12.1 Increasing power

In a fully assembled 19" control cabinet, twelve power modules each with an individual power of 30 kW can be scaled for one charging point. Therefore, a total power of up to 360 kW is available in parallel operation for supplying the DC load.

When supplying the DC load, the higher-level CHARX control controller regulates the balanced capacity utilization of the power modules. With a constant output voltage, the regulated asymmetrical deviation of the charging current is max. ± 0.5 A.

12.1.1 Parallel operation

When n power module DC outputs are connected in parallel in a 19" control cabinet, the output current is increased to $n \times I_N$. When 12 power module DC outputs are connected in parallel, the output current is increased to $12 \times I_N$. Each power module supplies a maximum output power of 30 kW at an output current of 100 A.

12.1.2 Fundamental prerequisites for parallel operation (power increase)

In order to ensure correct parallel operation of the power modules, observe the following rules:

Conductor cross-sections:

The connecting cables for supplying DC loads must be rated for the maximum occurring total current of all power modules.

Ambient conditions:

Select the installation location of the power modules such that the prevailing ambient conditions are identical. This is of particular importance if the power modules are installed in different installation locations. Large temperature differences between installation locations have a negative effect on the operating points of the power modules.

13 Derating

The power module is subject to derating influences that exist as individual influences or from combinations of influencing conditions.

13.1 Ambient temperature

When operated within the permissible temperature range for nominal operation, the power module provides the full output power. If the power module is operated outside the temperature range for nominal values, note the reduced output power for the supply of DC loads.

13.2 Output power

The output power of the power module depends directly on the prevailing ambient temperature at the installation site, output voltage, output current, and installation altitude. The following figure shows the interdependencies of the parameters.

Figure 28 Output power and its dependencies

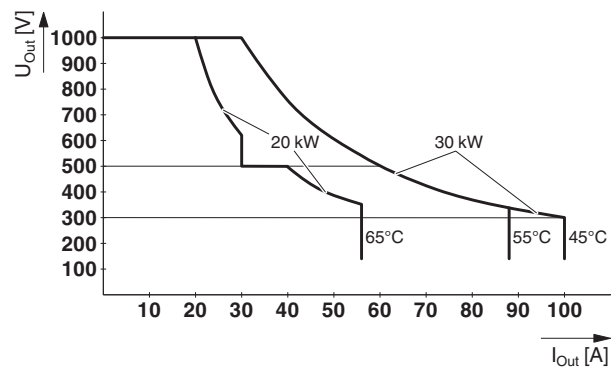

13.3 Installation height

The power module can be operated at an installation altitude of up to 2000 m without any limitations. Different data applies for installation locations above 2000 m due to the differing air pressure and the reduced cooling associated with it.

Figure 29 Output power depending on the installation height

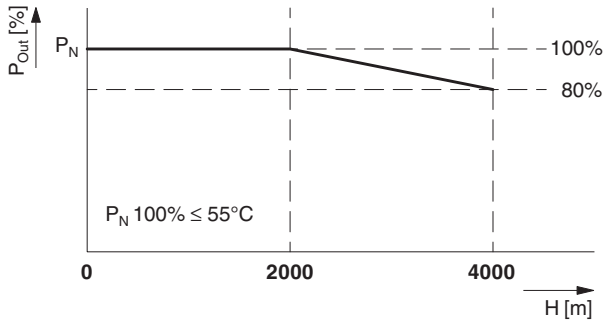

13.4 Position-dependent derating

The specified technical data for the power module is based on nominal operation in the horizontal mounting position. The power module is not subject to position-dependent derating. Operation in different mounting positions is also possible without limitations.

14 Disposal and recycling



Ensure the correct disposal of electronic components

Do not dispose of the power module as household waste.

Observe the applicable national standards and regulations.



Ensure correct disposal or recycling

Dispose of or recycle packaging material that is no longer needed as household waste.

Observe the applicable national standards and regulations.

15 Attachment

15.1 Application example with EV-PLCC-AC1-DC1 DC charging controller (1624130)

This application example describes the principle hardware and software connection of the CHARX PS/... power module to the superordinate EV-PLCC-AC1-DC1 charging controller (1624130).

The goal of this application example is:

- The communication path between the power module and superordinate charging controller is physically established
- CAN bus communication is established
- The charging controller transmits the specified output values (default values) to the power module
- Measure the following values at the DC output terminals of the power module. DC output voltage 300 V DC (without DC load), DC output current 50 A (only with suitable DC load)

The following hardware and software components are required for this:

Quantity	Designation	Item No.
1	CHARX PS-M2/825DC/1000DC/30KW power module	1296467
1	EV-PLCC-AC1-DC1 charging controller	1624130
1	CAN bus communication cable, RJ45 plug connection, open cable end	1415255
1	PC WORX DEMO software package for PC-based automation solutions	2985725
1	Application note AX SW SUITE CHANGE NOTES AUTOMATIONWORX Software Suite - Change notes at a glance (see download area - PC WORX DEMO)	
1	PC WORX StartUpPackage (see the download area of the charging controller)	
1	CANopen® termination resistor for RJ45 connectors	
1	Description of the CAN bus protocol CHARX PS-M2/... CAN BUS GCP Protocol Vx.x (see the download area of the power module)	
1	Service PC or notebook (state of the art)	
1	Ethernet communication cable (for connecting the service PC or notebook to the charging controller)	

15.2 CAN bus communication cable connection

Establish a physical communication path so that the power module can communicate bi-directionally with the DC charging controller.

Figure 30 Schematic diagram of the communication path

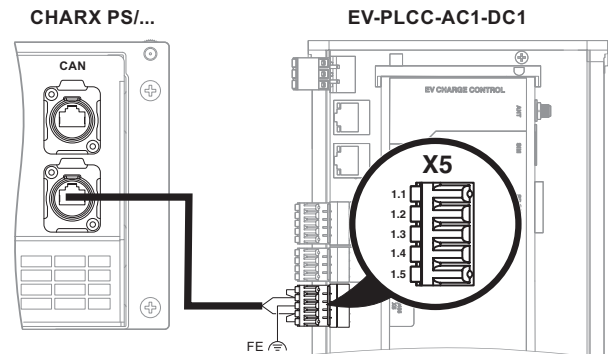
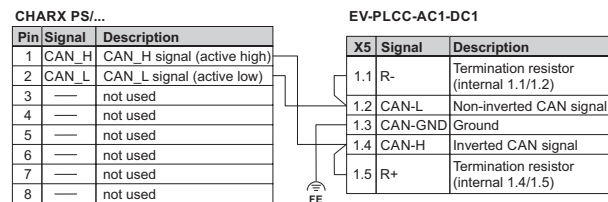

Figure 31 Connection assignment of the communication path



Terminate the power module with a CANopen® termination resistor for RJ45 connectors. To do this, plug the CANopen® termination resistor into the unassigned RJ45 connection socket.

On the charging controller, activate the termination resistor of the CAN bus communication interface. To do so, bridge connection terminal blocks X5:1.1 with 1.2 and X5:1.4 with 1.5, respectively.

Connect connection terminal block X5:1.3 on the charging controller to functional ground (⏚) at the installation location (control cabinet).

15.3 Downloading PC WORX StartUpPackage

The PC WORX StartUpPackage is necessary to operate the charging controller with the PC WORX engineering tool.



You will find the latest downloads for the item at phoenixcontact.net/products.

15.4 Unzipping and installing the PC WORX StartUpPackage

15.4.1 Step 1: Unzip StartUpPackage

Unzip the PC WORX StartUpPackage in your preferred folder on your service PC or notebook.

Figure 32 Unzipping StartUpPackage

Name	Date modified	Type
PCWORX Project	23/09/2021 13:57	File folder
Setup PCWORX SUITE 2020	23/09/2021 13:57	File folder
Setup PCWORX SUITE 2021	23/09/2021 13:57	File folder
Web Visu EVCC_Professionel_HTML5	14/10/2021 09:59	File folder
StartUpPackage_V1_44.zip	15/10/2021 08:21	zip Archive

15.4.2 Step 2: Start project

Start project EVCC_TrplChgr_Vx_xx_xx.zwt, located in the ...PCWORX Project folder.

Figure 33 Starting a project

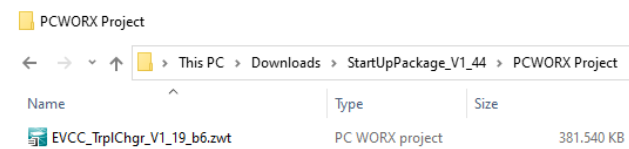

15.4.3 Step 3: Select the target directory

Select the target directory in which the project is to be installed. If the project is to be unzipped in the preset EVCC_TrplChgr_Vx_xx_xx.zw directory, click on the [Yes] button. If you want to create your own target directory, click on the [No] button and then specify the target directory.

Figure 34 Creating a project directory

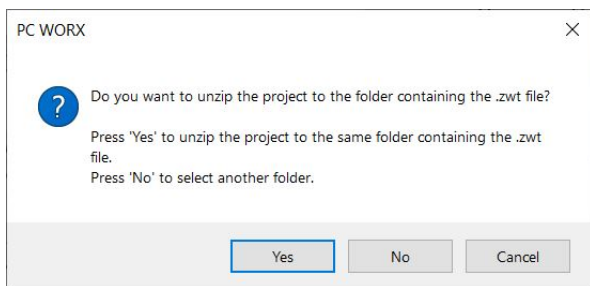

15.5 Step 4: Create a library

Install further libraries during the unzip process. These libraries contain functions that simplify the implementation of a charging point and communication with the power module. First select the *Do this for all similar conflicts* checkbox. Then click on the [Replace existing library with zipped library] button.

The following libraries will then be made available for selection:

Modbus, ReSyBasic, ReSyOCPP, SYS_PLC, IT_Library, IP_Com, EVCC_PROF_COM, EVCC_PROF_LIB, SE_Basic

Figure 35 Creating libraries

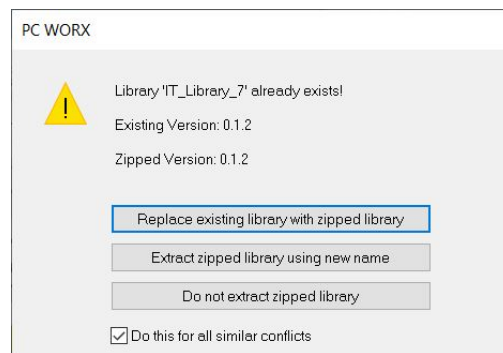

15.5.1 Step 5: Project tree in PC WORX

You will now find the installed libraries in the project tree on the left-hand side of the PC WORX interface. Each library contains a wide range of function blocks for electric vehicle charging stations.

Figure 36 Project tree in PC WORX

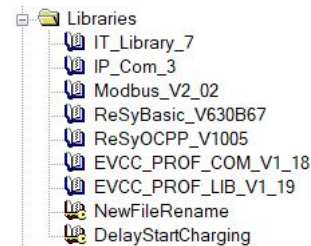

15.5.2 Step 6: Select a CAN* instance

Open the ...LogicalPOUs directory and select the CAN* instance from the subordinate directory structure.

Figure 37 Selecting CAN* instance

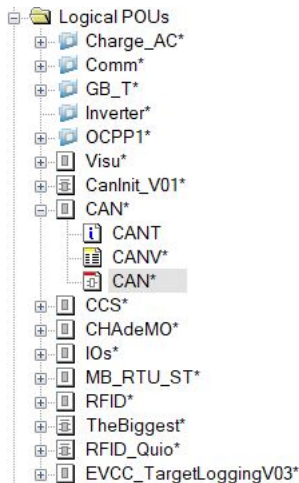

15.5.3 Step 7: Replace input variables

To enable the power module to activate the DC output and, at the same time, to be able to measure the specified static values at the DC output terminals, replace the specified variables with the following default values.

Input variable	Default value	Function
usiLinkStateCcs	USINT#13	Power module activation
diTargetVoltageEvCcs	DINT#300	Output voltage 300 [V]
diTargetCurrentCcs	DINT#50	Output current 50 [A]

Figure 38 Value supply via input variables

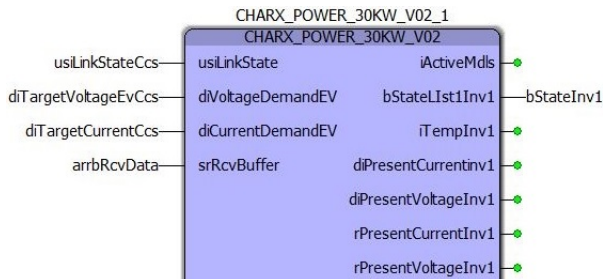
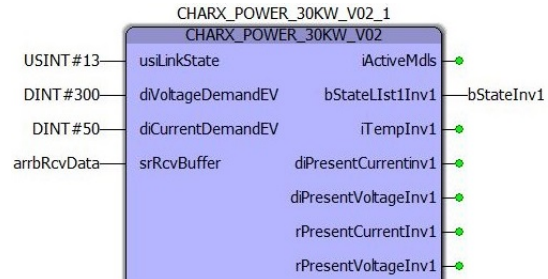

Figure 39 Value supply via default values (fixed value)



15.5.4 Step 8: IP address of the charging controller

- Select the *ViewBus Structure* menu command.

Figure 40 Selecting the *Bus Structure* menu command

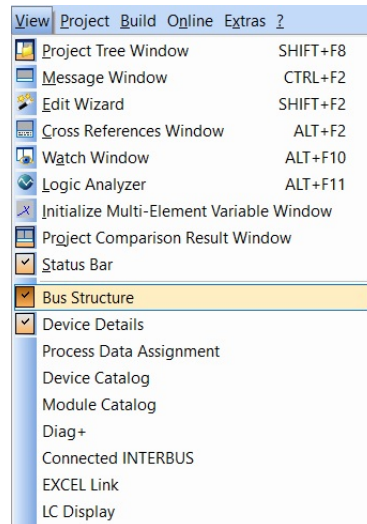

- To be able to display the IP address of the default charging controller, select the *ViewDevices Details* menu command.

Figure 41 Selecting the *Device Details* menu command

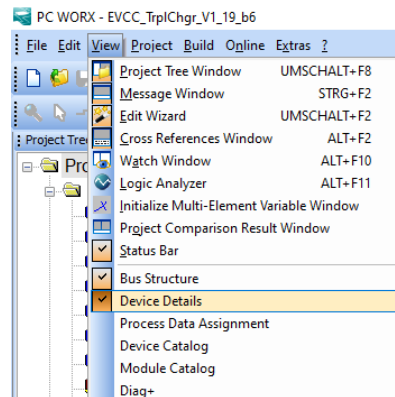

- The default IP address assigned to the charging controller (192.168.0.8) will now be displayed. If the IP address needs to be adjusted, do this in this dialog window.

Figure 42 Creating a project directory

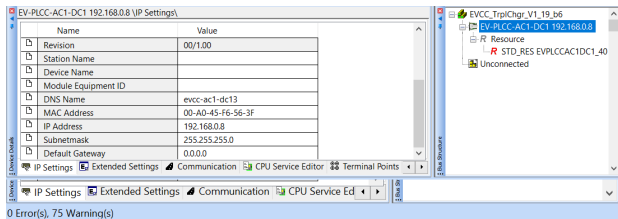

15.5.5 Step 9: Generate a program code

- Now generate the program code and load this onto the charging controller.
- Three buttons in the toolbar are necessary for this.
- Here, proceed in the order the buttons are described in.

1. [Rebuild Project] button



Click on this button to generate the program code.

2. [Download changes] button



Click on this button to transfer the program to the charging controller. The Run state will then be displayed in the control panel.

3. [Project Control Dialog] button



Click on this button to open the control panel.



If the charging controller does not switch to the Run operating state, click on the [Download] button in the control panel. Then click on the [Cold] button.

Figure 43 Control panel

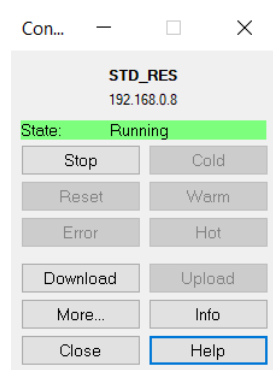

15.5.6 Step 10: Power module starts to operate

The charging controller now enables the power modules, and the program functions are executed. The DC output of the power module is controlled with the default values configured in the charging controller.

1. [Debug on/off] button



Click on the button to view the variables for the program runtime.

Output variable	Function
diPresentCurrentCcs	Shows the value of the output current 0 [A]
diPresentVoltageEvCcs	Shows the value of the output voltage 300 [V]

Figure 44 Output data of the current/voltage values

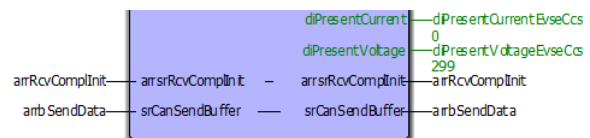

You now measure an output voltage of 300 V DC at the DC output terminals of the power module, even without a connected DC load.

To check the new output current value, connect a suitable DC load to the DC output terminals.