

CHARX PS-M2/... CAN BUS GCP Protocol V1.10

Data sheet
109960_en_01

© PHOENIX CONTACT 2021-08-11



1 Description

This document describes the CAN-based Grid Charge Protocol (GCP) communication protocol for communication between one or more power modules and a charging controller.

Here, the charging controller, as the superordinate controller, always handles communication with the bus devices on the linear CAN-BUS.

The CAN-based GCP communication protocol supports the following communication methods:

- Peer-to-peer
- Multicast
- Broadcast

Supported power modules

The following CHARX PS-M2... power modules are currently supported by the CAN-based GCP communication protocol:

Order designation	Order No.
CHARX PS-M2/3AC/1000DC/30KW	1232243
CHARX PS-M2/3AC/500DC/20KW	1232253
CHARX PS-M2/825DC/1000DC/30KW	1296467

Figure 1 Overview of the communication methods

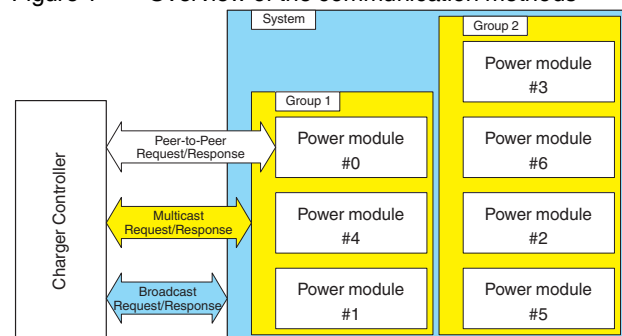

Table of contents

1	Description.....	1
2	Summary	3
2.1	CAN protocol.....	3
2.2	Communication procedure	3
2.3	Data type.....	3
2.3.1	Fixed point number	3
2.3.2	Floating point number	3
3	Frame format application and data definition	4
3.1	Frame format.....	4
3.2	Identifier	4
3.2.1	Error code	4
3.2.2	Device No.	4
3.2.3	Command No.....	4
3.2.4	Target address/source address	4
3.3	Command description	5
3.4	Status description.....	8
3.5	Communication methods with addressing examples	9
4	Reference.....	10
4.1	Recommended sequence when switching on	10
4.2	Recommended sequence when shutting down.....	10
4.3	Example of communication sequence.....	10

2 Summary

2.1 CAN protocol

- Uses the extended frame mode CAN 2.0B
- The bit rate is 125 Kbps
- Linear CAN bus topology limited to 30 devices
- 120 Ω termination resistors for terminating the CAN bus

2.2 Communication procedure

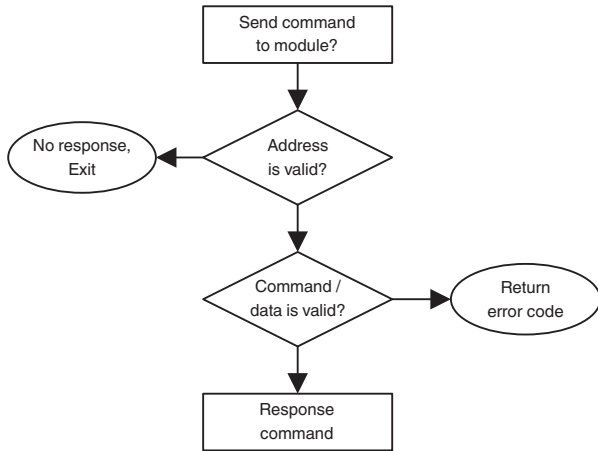

2.3 Data type

Send the bytes in an increasing sequence. Begin with byte 0. Depending on the command number, the data type of the command can contain fixed point or floating point numbers.

2.3.1 Fixed point number

A fixed point number can take up a length of 1 to 4 bytes. The detailed format can be found in Section 3.3 – Command description.

2.3.2 Floating point number

The storage format of the floating point number is 4 bytes and is sent in the following sequence: sign bit, code, mantissa high bit, and mantissa low bit.

The floating point number uses the IEEE 32-bit standard format for floating point numbers (standard format for floating point numbers for the C programming language), whereby the length is 32 bits and the format is structured as follows:

D31	D30-D23	D22-D16	D15-D8	D7-D0
Sign of the floating point number	Code	Mantissa high bit	Mantissa middle bit	Mantissa low bit

If the code is E and the mantissa is M, then: floating point number = $\pm(1+M \times 2^{-23}) \cdot 2^{E-127}$. Whether the floating point number is positive or negative depends on the value of the sign bit (S). S = 1 means that the floating point number is negative, and S = 0 means that the floating point number is positive.

Example: If the 32-bit floating point number is 43H, FAH, 00H, and 00H (S = 0, E = 135, M = $0x7A0000 = 61 \times 2^{17}$), the value of the floating point number $(1+61 \times 2^{17} \times 2^{-23}) \cdot 2^{135-127} = 500$.

If the floating point number is 40.0, then the transmission sequence is 42, 20, 00, 00.

If the floating point number is 2.40, then the transmission sequence is 40, 19, 99, 9A.

3 Frame format application and data definition

3.1 Frame format

Communication between the superordinate charging controller and one or more power module is via CAN 2.0B frames.

The frame format is illustrated in the following table:

Description	Code
Start of frame	SOF (1 bit)
Arbitration field	Identifier (11 bits)
	SRR
	IDE
	Identifier (18 bits)
	RTR
Control field	Reserved (1 bit)
	Data Len (4 bits)
Data field	Data (0-8 bytes)
CRC field	CRC (16 bits)
Ack field	Ack (2 bits)
End of frame	(7 bits)

The data length in this protocol is 8 bytes. The controllable part is comprised of the identifier and the data.

Identifier		Data		
29 bits	Byte 0	Byte 1	...	Byte 7
Identifier	Data (8 bytes)			

3.2 Identifier

28-26	25-22	21-16	15-8	7-0
Error code (3 bits)	Device No. (4 bits)	Command No. (6 bits)	Target address (8 bits)	Source address (8 bits)

3.2.1 Error code

Error code	Description
0x00	Normal
0x01	/
0x02	Command invalid
0x03	Data invalid
/	/
0x07	Start of processing

3.2.2 Device No.

Device No.	Description
0x0A	Protocol between the charging controller and the individual power module
0x0B	Protocol between the charging controller and a module group

3.2.3 Command No.

Detailed information can be found in Section 3.3 – Command description.

3.2.4 Target address/source address

Peer-to-peer

Describes equal-authority communication between the charging controller and individual power modules. The request/response pattern is reciprocal.

For peer-to-peer addressing, the target address is the automatically assigned module address. Set the device number to the value 0x0A.

Multicast

Describes the communication between the charging controller and a group of power modules. The charging controller sends a request with a group address. Depending on the command sent (command No.), individual or all modules in the group respond. Set the device number to the value 0x0B.

Broadcast

Describes the communication between the charging controller and the entire system. The charging controller sends a request as a broadcast message.

For broadcast addressing, the target address is 0x3F. Set the device number to the value 0x0A.

	Target address/source address							
	Bit 7	Bit 6	Bit 5	Bit 4	Bit 3	Bit 2	Bit 1	Bit 0
Power module	Reserved (0.0)		Module address: 00–0x3B, broadcast address: 3F					
Charging controller	Charging controller address: 0xF0–0xF8, Standard address: 0xF0							

- 30 power modules are supported in parallel.
- The power module will be assigned an address automatically after power on. The group number is set via the DIP switch on the panel.
- During the startup phase the power modules exchange messages with error code 0x07: “Start of processing” in order to allocate an address and exchange group information. At this time, the user may not send commands to the power module.

3.3 Command description



Note

In the following table, please note that the abbreviation Mdl = power module and Ctrl = charging controller in the listed examples.

Command No.	Description								
0x01	Read system information								
	Peer-to-peer: No								
	Multicast: Yes, response only from group coordinator								
	Broadcast: Yes, response from system coordinator								
		Byte 0	Byte 1	Byte 2	Byte 3	Byte 4	Byte 5	Byte 6	Byte 7
	Request	0	0	0	0	0	0	0	0
Response	Vo: System output voltage (floating point)				Io: Total system output current (floating point)				
Example	Ctrl transmits: 02 81 3F F0		00 00 00 00 00 00 00		Read system information				
	Mdl responds: 02 81 F0 3F		43 FA 00 00 42 48 00 00		Response Vo 500 V, Io_total 50 A				
	Ctrl transmits: 02 C1 01 F0		00 00 00 00 00 00 00		Read group #1 information				
	Mdl responds: 02 C1 F0 01		43 FA 00 00 40 A0 00 00		Response Vo_group_1 500 V, Io_group_1 5 A				
0x02	Read system information								
	Peer-to-peer: No								
	Multicast: Yes, response only from group coordinator								
	Broadcast: Yes, response from system coordinator								
		Byte 0	Byte 1	Byte 2	Byte 3	Byte 4	Byte 5	Byte 6	Byte 7
	Request	0	0	0	0	0	0	0	0
Response	0	0	Mdl quantity	0	0	0	0	0	
Note	Multicast addressing: The module returns the number of power modules in the group Broadcast addressing: The module returns the number of power modules in the system								
Example	Ctrl transmits: 02 82 3F F0		00 00 00 00 00 00 00		Read number of power modules in the system				
	Mdl responds: 02 82 F0 3F		00 00 07 00 00 00 00		7 power modules detected in the system				
	Ctrl transmits: 02 C2 01 F0		00 00 00 00 00 00 00		Read number of power modules in the group				
	Mdl responds: 02 C2 F0 01		00 00 03 00 00 00 00		3 power modules detected in group 1				
0x03	Read power module information								
	Peer-to-peer: Yes								
	Multicast: Yes, response from every power module in the group								
	Broadcast: No								
		Byte 0	Byte 1	Byte 2	Byte 3	Byte 4	Byte 5	Byte 6	Byte 7
	Request	0	0	0	0	0	0	0	0
Response	Power module #N output voltage (floating point)				Power module #N output current (floating point)				
Example	Ctrl transmits: 02 83 00 F0		00 00 00 00 00 00 00 00 43		Read power module #0 information				
	Mdl responds: 02 83 F0 00		FA 00 00 40 60 00 00		Power module #0 Vo 500 V, Io 3.5 A				
0x04	Read power module status								
	Peer-to-peer: Yes								
	Multicast: Yes, response from every power module in the group								
	Broadcast: No								
		Byte 0	Byte 1	Byte 2	Byte 3	Byte 4	Byte 5	Byte 6	Byte 7
	Request	0	0	0	0	0	0	0	0
Response	0	0	Mdl group#	0	Mdl temperature	Mdl status 2	Mdl status 1	Mdl status 0	
Note	Module temperature is a signed character, 8 bits, -128°C to +127°C								
Example	Ctrl transmits: 02 84 01 F0		00 00 00 00 00 00 00		Read power module #1 information				
	Mdl responds: 02 82 F0 01		00 00 02 00 1B 00 40 00		Power module #1 belongs to group #2, module temperature 27°C, enable access				

Command No.	Description								
0x06	Read AC/DC input voltage information								
	Peer-to-peer: Yes								
	Multicast: Yes, response from every power module in the group								
	Broadcast: No								
		Byte 0	Byte 1	Byte 2	Byte 3	Byte 4	Byte 5	Byte 6	Byte 7
	Request	0	0	0	0	0	0	0	0
Response	$V_{L1_L2} / V_{IN} / V_{\pm}$ high byte	$V_{L1_L2} / V_{IN} / V_{\pm}$ low byte	V_{L2_L3} high byte	V_{L2_L3} low byte	V_{L3_L1} high byte	V_{L3_L1} low byte	0	0	
Note	Single phase is V_{IN} , unit is 0.1 V								
Example	Ctrl transmits: 02 86 01 F0			00 00 00 00 00 00 00			Read power module #1 information		
	Mdl responds: 02 86 F0 01			0F B4 0F A5 0F A7 00 00			Power module #1 L1_L2 402 VL2_L3 400.5 V L3_L1 400.7 V		
0x0C	Read power module information								
	Peer-to-peer: Yes								
	Multicast: Yes, response from every power module in the group								
	Broadcast: No								
		Byte 0	Byte 1	Byte 2	Byte 3	Byte 4	Byte 5	Byte 6	Byte 7
	Request	0	0	0	0	0	0	0	0
Response	Vext high byte	Vext low byte	lavail high byte	lavail low byte	0	0	0	0	
Note	Unit is 0.1 V/0.1 A Vext is the actual voltage on the output terminals of the module; lavail is the currently available module current								
Example	Ctrl transmits: 02 8C 00 F0			00 00 00 00 00 00 00			Read Mdl #0 information		
	Mdl responds: 02 8C F0 010			13 58 01 66 00 00 00 00			Mdl #0 external voltage 495.2 V, available output current 35.8 A		
0x1A	Switch operational readiness on/off								
	Peer-to-peer: Yes								
	Multicast: Yes, response from every power module in the group								
	Broadcast: Yes, without response								
		Byte 0	Byte 1	Byte 2	Byte 3	Byte 4	Byte 5	Byte 6	Byte 7
	Request	0 = on 1 = off	0	0	0	0	0	0	0
Response	0	0	0	0	0	0	0	0	
Note									
Example	Ctrl transmits: 02 9A 3F F0			01 00 00 00 00 00 00			Switch off all modules		
	Mdl responds: 02 9A 01 F0			01 00 00 00 00 00 00			Switch off power module #1		
	Mdl responds: 02 9A F0 01			01 00 00 00 00 00 00			Power module #1 response OFF		
	Ctrl transmits: 02 DA 02 F0			01 00 00 00 00 00 00			Switch off power modules in group #2		
0x1B	Set system output voltage and total output current								
	Peer-to-peer: No								
	Multicast: Yes, response only from group coordinator								
	Broadcast: Yes, response from system coordinator								
		Byte 0	Byte 1	Byte 2	Byte 3	Byte 4	Byte 5	Byte 6	Byte 7
		MSB			LSB	MSB			LSB
Request	Output voltage (mV)				Total output current (mA)				
Response	Output voltage (mV)				Total output current (mA)				
Note	Multicast addressing: System output voltage and total output current for the entire group Broadcast addressing: System output voltage and total output current for the entire system								
Example	Ctrl transmits: 02 9B 3F F0			00 04 93 E0 00 00 27 10			Set all power modules to Vo 300 V, Io_total 10 A (If there are 2 power modules in the system, then the Io of each power module is 5 A)		
	Ctrl transmits: 02 DB 02 F0			00 03 0D 40 00 00 13 88			Set group #2 to Vo 200 V, Io_group_2_total 5 A (If there are 2 power modules in a group, then the Io of each power module is 2.5 A)		
	Mdl responds: 02 DB F0 02			00 03 0D 40 00 00 13 88			Read power module numbers in this group		

Command No.	Description								
0x1C	Set the output voltage and output current of a power module								
	Peer-to-peer: Yes								
	Multicast: Yes, response from every power module in the group								
	Broadcast: Yes, without response								
		Byte 0	Byte 1	Byte 2	Byte 3	Byte 4	Byte 5	Byte 6	Byte 7
		MSB			LSB	MSB			LSB
	Request	Output voltage (mV)				Output current (mA)			
	Response	Output voltage (mV)				Output current (mA)			
	Note	The coordinating power module responds with the actual set value.							
	Example	Ctrl transmits:	02 9C 3F F0	00 04 93 E0 00 00 27 10	Set all power modules to Vo 300 V, Io 10 A				
	Ctrl transmits:	02 DC 02 F0	00 03 0D 40 00 00 13 88	Set group #2 to Vo 200 V, set lo_group_2 to 5 A for each power module in group #2					
	Mdl responds:	02 DC F0 00	00 03 0D 40 00 00 13 88	Group #2 power modules #0					
	Mdl responds:	02 DC F0 01	00 03 0D 40 00 00 13 88	Group #2 power modules #1					

3.4 Status description

	Bit	Description	Condition	Power module status	LED
Status 2	7	1: PFC circuit is OFF	1: PFC circuit is OFF	OFF	
	6	1: Overvoltage at the input	1: Vin >535 V 0: Vin <520 V	OFF	Yellow
	5	1: Undervoltage at the input	1: Vin <255 V 0: Vin >275 V	OFF	Yellow
	4	1: Input asymmetry	/	/	/
	3	1: Input phase lost	1: One phase lost (input overvoltage if single phase first)	OFF	Yellow
	2	1: Load sharing	1: lavg_system >20%, I0 <2%	ON	Red
	1	1: Module ID repetition	1: Bar code or address repetition	OFF	Red
	0	1: Current limitation	1: Limitation of the output power for high temperatures or low input voltages	ON	/
Status 1	7	1: CAN command interruption	1: No CAN signal from the charging controller for 10 seconds	OFF	Flashing yellow
	6	1: Enable access	1: Enable access status	/	Red
	5	1: Overvoltage at the output	1: Vo > overvoltage point 0: Vext > Vext overvoltage point	OFF	Yellow
	4	1: Temperature threshold value exceeded	1: Temperature threshold ambient temperature >80°C or PCB temperature >100°C (reference value)	OFF	Yellow
	3	1: Fan error	1: Fan error signal active	OFF	Flashing red
	2	1: Module protection	1: Input undervoltage or input overvoltage or overtemperature	OFF	Yellow
	1	1: Module error	1: Output overvoltage or output short circuit or power module ID repetition or no load sharing	OFF (except load sharing)	Red
	0	1: DC side is OFF	1: DC side is OFF		
Status 0	7				
	6				
	5	1: Discharge abnormal	1: Vo >50 V 2 seconds after OFF	ON	Yellow
	4				
	3	1: PFC circuit abnormal	1: Vbus overvoltage/undervoltage or Vin overvoltage/undervoltage or overtemperature	OFF	Yellow
	2	1: Internal communication interruption	1: Communication interruption between PFC and DC	OFF	Yellow/red*
	1				
	0	1: Output short circuit	1: Vo <25 V, Io >10% for 2 seconds	OFF	Red

* Red if the internal communication is interrupted for longer than 2 minutes



Note: Communication interruption

If the power module does not receive any signals from the charging controller within 10 seconds, the power module switches off.



Note: Interval time for controller requests

The interval time for control requests should be between 50 ms and 200 ms.

3.5 Communication methods with addressing examples



Note: Different address ranges

Different address ranges for the response/request are used for the different communication methods.

The following examples apply for the examples shown: Group 0x03 is assigned to Mdl#0, Mdl#1

Peer-to-peer addressing

	Request	Response
		Mdl#0
Source address	0xF0	0x00
Target address	0x00	0xF0
Command No.	0x03	0x03
Device No.	0x0A	0x0B
Error code	0x00	0x00

Identifier	0x028300F0	0x0283F000
------------	------------	------------

Multicast addressing with group response

Command 0x01, 0x02, 0x1B

	Request	Response
		Group 0x03
Source address	0xF0	0x03
Target address	0x03	0xF0
Command No.	0x01	0x03
Device No.	0x0B	0x0B
Error code	0x00	0x00

Identifier	0x02C303F0	0x02C3F003
------------	------------	------------

Multicast addressing with module response

Command 0x03, 0x04, 0x06, 0x0C, 0x1A, 0x1C

	Request	Response	
		Mdl#0	Mdl#1
Source address	0xF0	0x00	0x01
Target address	0x00	0xF0	0xF0
Command No.	0x03	0x03	0x03
Device No.	0x0B	0x0B	0x0B
Error code	0x00	0x00	0x00

Identifier	0x2C300F0	0x2C3F000	0x2C3F001
------------	-----------	-----------	-----------

Broadcast addressing with response

Command 0x01, 0x02, 0x1B

	Request	Response
		System coordinator
Source address	0xF0	0x3F
Target address	0x03	0xF0
Command No.	0x01	0x01
Device No.	0x0A	0x0A
Error code	0x00	0x00

Identifier	0x02813FF0	0x0281F03F
------------	------------	------------

Broadcast addressing without response

Command 0x1A, 0x1C

	Request
Source address	0xF0
Target address	0x03
Command No.	0x01A
Device No.	0x0A
Error code	0x00

Identifier	0x029A3FF0
------------	------------

4 Reference

4.1 Recommended sequence when switching on

- Power on
- Set the output voltage and output current for the power module
- Close the system relay
- Switch the power module on

4.2 Recommended sequence when shutting down

- Switch the power module off
- Open the system relay

4.3 Example of communication sequence

The following table illustrates the communication sequence between the superordinate charging controller and three power modules.

	Direction	ID	Data	Description	
	Power module receives	02 9A 3F F0	01 00 00 00 00 00 00 00	Switch off all modules (ensure defined status)	
Set and call up information continuously	Power module receives	02 9C 3F F0	00 0B 71 B0 00 00 3A 98	Set 750 V, 15 A	
		02 9A 3F F0	00 00 00 00 00 00 00 00	Switch all modules on (begin charging)	
		02 81 3F F0	00 00 00 00 00 00 00 00		
	Power module transmits	02 81 F0 3F	44 3B 80 00 41 6F 33 33	750 V, 14.95 A	
	Power module receives	02 82 01 F0	00 00 00 00 00 00 00 00		
	Power module transmits	02 82 F0 01	00 00 03 00 00 00 00 00	3 modules in the system	
	Power module receives	02 9C 3F F0	00 0B 71 B0 00 00 3A 98		Set 750 V, 15 A
		02 9A 3F F0	00 00 00 00 00 00 00 00		Switch all modules on
		02 84 00 F0	00 00 00 00 00 00 00 00		
	Power module transmits	02 84 F0 00	00 00 00 00 16 00 40 00	Power module #0, 22°C, access enabled	
	Power module receives	02 84 01 F0	00 00 00 00 00 00 00 00		
	Power module transmits	02 84 F0 01	00 00 00 00 18 00 40 00	Power module #1, 24°C, access enabled	
	Power module receives	02 84 02 F0	00 00 00 00 00 00 00 00		
	Power module transmits	02 84 F0 02	00 00 00 00 17 00 40 00	Power module #2, 23°C, access enabled	
	Power module receives	02 9A 3F F0	01 00 00 00 00 00 00 00	Switch off all modules (end charging, ensure defined status)	



Note: Use of frame 0x0757F8XX in the charging controller not permitted

The power modules use the frame 0x0757F8XX for internal communication with each other. Additional use of this frame in the charging controller is not permitted.