

((PaPIRs)))

FAQ's

PIR MOTION SENSORS 2020



Special designs from Panasonic that provide high sensitivity and reliability

Operating principle, usage related

Q1-1: Can a single Panasonic Passive Infrared sensor detect the specific position of where person is located in an area? 6

Q1-2: Can Panasonic Passive infrared sensors detect even if human body temperature is lower than ambient temperature? 6

Q1-3: Do Panasonic Passive infrared sensors detect animals or other objects aside from humans? 6

Q1-4: Is light for motion detection constantly emitted from the lens? 7

Q1-5: Although the detection range of standard lens type is 5m, is it possible for detection distance to be shorter? 7

Q1-6: How long is the detectable infrared wavelength? 8

Q1-7: What are "pyroelectric elements"? 8

Q1-8: Is it possible to use PaPIRs in outdoor applications? 9

Q1-9: How should the sensor be waterproofed? 9

Q1-10: Can I change the detection area? 10

Q1-11: Can the sensor be installed on a moving body? 10

Q1-12: Is detection possible when the distance between the person and the sensor is almost zero? . . . 11

Q1-13: Can Panasonic Passive infrared sensors detect through a transparent plate such as glass or acrylic? 11

Q1-14: Does the detection sensitivity change due to the ambient temperature? 11

Q1-15: Is there any impact by sunlight? 12

Q1-16: Does detection performance change depending on clothes? 12

Q1-17: What is an effective method for pet immunity? 13

Q1-18: Does airflow around the sensor have any influence on detection performance? 14

Electrical connection, output signal related

Q2-1: How should the sensor be wired? 16

Q2-2: Can the circuit stabilization time (wait time) be shortened? 17

Q2-3: Can the AC load be turned on and off directly? 17

Q2-4: Are there any sensors with an operating voltage of 12V DC or 24V DC? 18

Q2-5: Is it possible to design a common circuit for multiple sensors? 18

Q2-6: How do I set a timer for the output? 19

Q2-7: Does the performance change depending on the operating voltage? 19

Q2-8: What is the duration for the digital output signal during a detection? 20

Q2-9: If a person keeps moving in the detection area, what kind of output appears from the digital
output type sensor? 21

Q2-10: What is the duration of the digital output signal from the sensor after a detection? 22

Q2-11: How much time elapses after the person stops moving within the detection area and before the
signal becomes a “definite” OFF? 22

Q2-12: Why doesn’t the sensor have a timer circuit for setting the output time? 22

Q2-13: Can the sensor handle external surges and electrical noise? 23

Q2-14: What is a comparator? 23

Q2-15: What are sleep mode, standby mode, and mask mode? 24

Q2-16: How to reinforce power source noise? 25

Q2-17: What is the operating process for output current? 26

Related to product specifications, etc.

Q3-1: Will the sensor detect anything beyond the “maximum distance” specified in the catalog? 28

Q3-2: How is the detection area of Panasonic infrared sensors determined? 29

Q3-3: What does “temperature difference of 4°C or more against background” mean? 30

Q3-4: How is product life cycle calculated? 31

Q3-5: What is the TO-5 metal package? 31

Q3-6: Is it possible to use reflow soldering? 31

Q3-7: How can we confirm detection performance based on the specification? 32

Q3-8: Is there any correlation between sensitivity and distance? 33

Q3-9: What is NEP (Noise Equivalent Power)? 34

Q3-10: What is D^* (ratio of detection performance)? 35

■ Source

The information contained in this document is based on the information as of March 2020.
The information provided in this document is subject to change without notice.

■ Caution for use of FAQ's

This FAQ's should be for referential purposes only.
When adopting our products, please make sure that you evaluate our products with your actual equipment after carefully reviewing the latest information in the specification sheets or catalogs and decide the availability on your own responsibility.
Please note that this FAQ's is based on our estimated of compatibility with other manufacturer's products, based on the information provided by those manufacturers, at the time the data was published.
We are not responsible for any incorrect or incomplete information in this FAQ's.
The information is subject to change at any time without notice.

Operating principle, usage related

Q1-1**Can a single Panasonic Passive Infrared sensor detect the specific position of where person is located in an area?**

No, specific position detection of a person is not possible.

Panasonic passive infrared sensors have a QUAD sensing element, meaning only one sensor component with four pyroelectric, heat receiving elements which are all interconnected. The lens determines the size and shape of the detection area, as well as the distribution and number of the switching zones.

Therefore, because there is only one sensor component, it cannot identify where the infrared source is coming from within the detection area.

On the other hand, if you use multiple Panasonic passive infrared sensors, it may be possible to identify the approximate position of person.

Q1-2**Can Panasonic Passive infrared sensors detect even if human body temperature is lower than ambient temperature?**

Yes, detection is possible.

Panasonic Passive infrared sensors are able to detect movement through the interpretation of temperature differentials. A human body can be detected whether it is higher or lower than the ambient temperature. However, since the surface of the human body is affected by the ambient temperature to a certain extent, the sensitivity of the sensor may deteriorate if the body and ambient temperatures equalize.

Q1-3**Do Panasonic Passive infrared sensors detect animals or other objects aside from humans?**

Yes, detection is possible.

Pyroelectric sensors react to a change in intensity of infrared radiation within the specified detection criteria. All objects on earth emit infrared radiation and are therefore detected if they are moving and the if change in intensity is large enough to be detected (animals, insects, cleaning robots, curtains, flying objects, rain, etc.).

Q1-4

Is light for motion detection constantly emitted from the lens?

No, light is never emitted from the sensor.

PaPIRs are passive infrared sensors, which means that they do NOT emit infrared radiation to detect motion. Instead, the sensor operates by receiving infrared radiation emitted from a moving object. Therefore it is called a “Passive type” sensor.

Q1-5

Although the detection range of standard lens type is 5m, is it possible for detection distance to be shorter?

Yes, although the sensor itself can not adjust detection distance on its own due to the principal of its operation. In order to set the limitation of detection range, the sensor should be pointed toward an obstacle such as ground, wall, or ceiling.

Additionally, it is also effective to limit the detection range by blocking the incoming infrared light by using a transmittance reducing material in front of the lens like Polyethylene.

Another possibility would be to use the analog sensor with amplifier output. With this sensor you can adjust the sensitivity to a certain degree by adjusting the switching thresholds within a software or with the help of a window comparator.

- Setting the sensor so it will not detect people who are far away

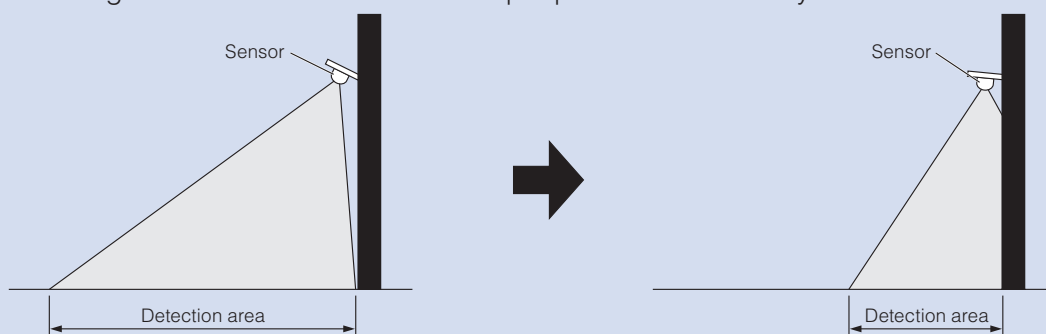

- For detection in only a limited area

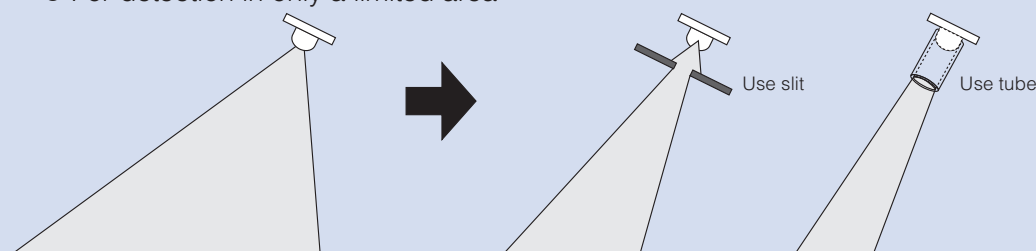

Q1-6

How long is the detectable infrared wavelength?

As indicated below, the sensor uses an optical filter with light transmission characteristics of approximately 5µm or longer.

It is defined as a long wavelength (far infrared) which is from approximately 5 - 15µm.

■ Wavelength characteristics

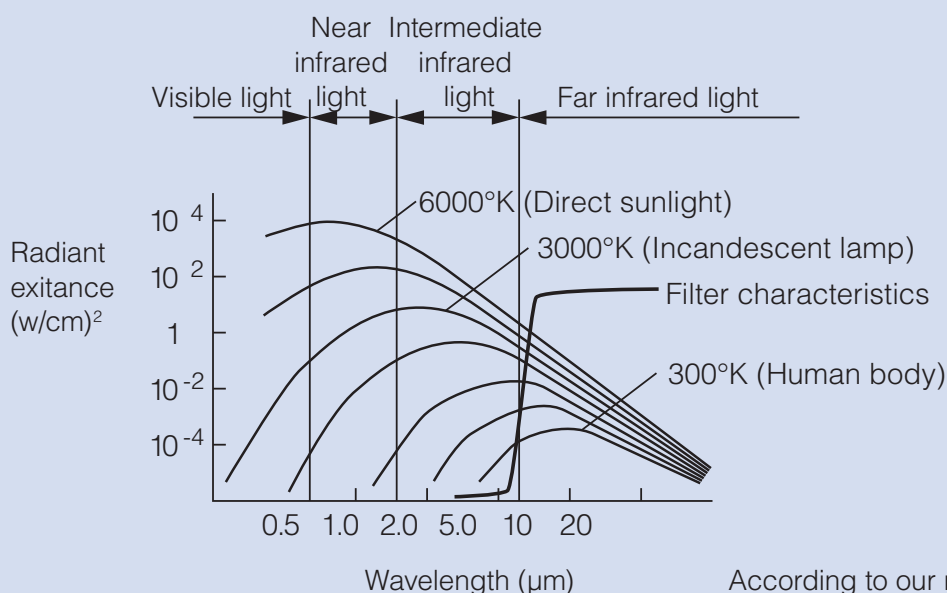

Q1-7

What are "pyroelectric elements"?

Pyroelectric elements are pyroelectric crystals provided with electrodes. With the help of an optical system, incident infrared radiation emitted by a moving person, for example, is focused on these pyroelectric elements by means of a lens, causing the crystals to change temperature. This temperature change leads to a charge shift at the electrodes. This charge shift generates a measurable voltage which is used to detect moving objects within the specified detection area.

PaPIRs are quad sensors, which means that four pyroelectric crystals are connected together on a carrier substrate. In contrast to sensors with one or only two pyroelectric elements, the probability of a triggering error is reduced with a quad sensor. False triggers can usually be caused by thermal interference sources in the environment, for example, by spontaneous shading of an object heated by the sun or quickly adjustable heat sources.

Q1-8

Is it possible to use PaPIRs in outdoor applications?

Only with certain precautions.

Panasonic passive infrared sensors are designed for indoor use with common indoor electronic devices.

If you need to use a sensor outdoors please take measures to waterproof the sensor and protect it from dust, condensation, and freezing.

There are many causes of temperature changes outdoors and because of that detection errors may result.

Operating principle, usage related

Q1-9

How should the sensor be waterproofed?

The sensor itself is not water-proof.

It is necessary to take water-proof measures by using O-rings or gaskets for example or HDPE suitable potting material (please contact potting material experts for HDPE suitable potting materials).

The high-density, long-distance, and low-profile lenses have a step for which O-rings or gasket seals can be placed (maybe CAD based pictures are a little bit more representative here).

Electrical connection, output signal related

Related to product specifications, etc.

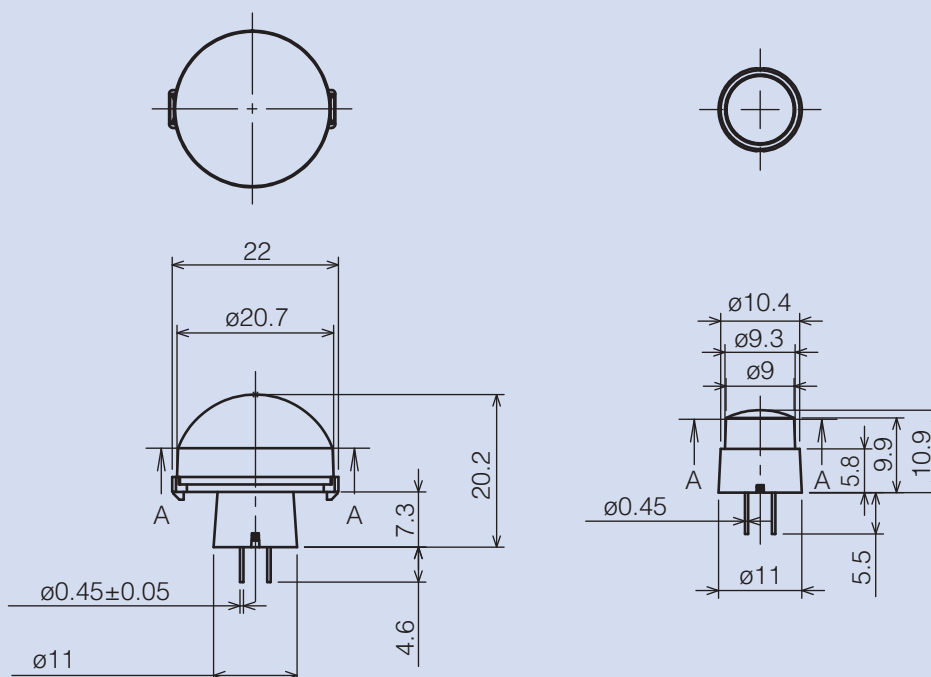

[$\varnothing 20.45\text{mm}$ (High density & Long-distance)] [$\varnothing 9.3\text{mm}$ (Low-profile)]

Q1-10

Can I change the detection area?

Yes, you can depending on the setting.

The detection area can be changed by changing the angle of the mounting of the sensor and by placing a cover with a slit or a mask in front of the sensor that limits the area detected by reducing the F.O.V. (Field of View).

If you find it difficult to calculate the desired detection area, please ask us. We can possibly create a field of view simulation upon request.

- Setting the sensor so it will not detect people who are far away

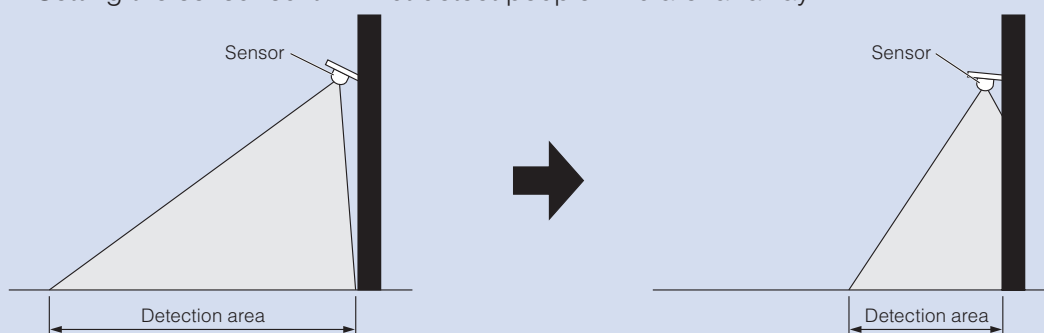

- For detection in only a limited area

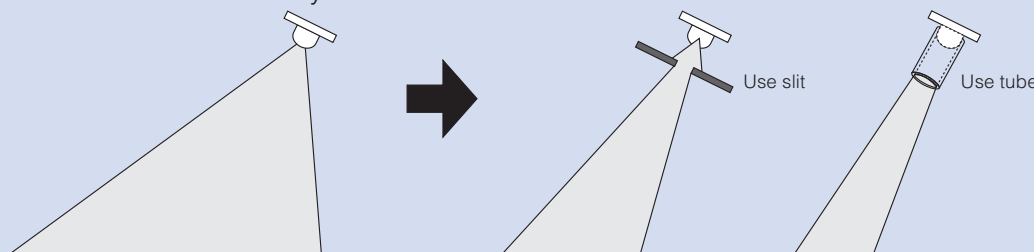

Q1-11

Can the sensor be installed on a moving body?

No, the sensor is not suitable for mounting on moving objects.

PaPIRs are normally installed in stationary devices. When an object enters the detection area, the sensor detects a change in the amount of infrared radiation in the detection area.

If the sensor were to move, it would mistake changes in wall and floor temperature for a moving object, which would incorrectly lead to detection.

Strong shocks and vibrations can cause false alarms too, and in the worst case damage the sensor.

Q1-12 Is detection possible when the distance between the person and the sensor is almost zero?

Yes.

Panasonic Passive infrared sensors detect when a human enters or exits the specified detection area.

However, if the person is too close to the sensor, the entire detection area is covered by the upper body, for example. As a result, temperature changes are less likely to occur with small movements in the detection area.

In addition, detection can be difficult if a person moves through the detection area at an extremely short distance, very quickly. In this case, the temperature change could be too fast for the sensor.

Q1-13 Can Panasonic Passive infrared sensors detect through a transparent plate such as glass or acrylic?

No, it cannot a person through these materials.

The wavelength which can be detected by this sensor is over $5\mu\text{m}$.

Ordinary, light wavelengths passing through glass are limited to $2\mu\text{m}$. Since the sensor can only detect infrared wavelengths greater than $5\mu\text{m}$, glass would render the sensor unable to detect a person on the other side.

As an alternative we suggest using a polyethylene sheet which allows for infrared light to pass through. However, if a sensor is placed opposite or close to a window, etc., it may react if the ambient temperature changes quickly enough, for example if the sun is shaded by clouds, etc.

Q1-14 Does the detection sensitivity change due to the ambient temperature?

Yes, it does.

During summer, when the difference between surface temperature of a human body and the background temperature is small, the sensitivity decreases. Conversely, during the winter, the sensitivity can increase all depending on amount of temperature differential between the object and background ambient.

Q1-15 Is there any impact by sunlight?

Yes, there is.

When sunlight suddenly illuminates or shades the sensor, a change in temperature occurs.

The sensor may detect this change, and there is a possibility to trigger a false detection. Therefore, we recommend that the sensor should be installed at a place where it is not in direct sunlight.

Q1-16 Does detection performance change depending on clothes?

Yes, it does.

Since Panasonic Passive infrared sensors detect the difference between the ambient temperature and the human body, the detection performance changes depending on the state of the target object and the ambient temperature.

Regarding the change due to clothes, this depends on how much skin is exposed. The human body emits more infrared light when more skin is exposed. The more energy radiated from the human body, the easier it is for the sensor to recognize infrared energy. Although people tend to cover up more with clothing during colder environments and winter seasons, the actual detection performance is actually still better in these climates. This is because the ambient temperature is lower in winter and the effect of lowering ambient temperature has a greater effect than the change of infrared emitted by the person due to clothing.

Generally, it is necessary to pay attention to changes in the ambient temperature more than the affects of clothing.

Q1-17

What is an effective method for pet immunity?

There is no true “Pet Immunity” type PIR sensor from Panasonic.

You can install the “wall installation detection” lens type upside down and tilt the lens so that the detection area does not cover near the ground.

However, this is only possible with smaller animals. Larger dogs for example could be detected. But also cats or dogs that move into the detection area trigger the sensor, for example when they jump or climb on an elevation (create a 3D CAD picture).

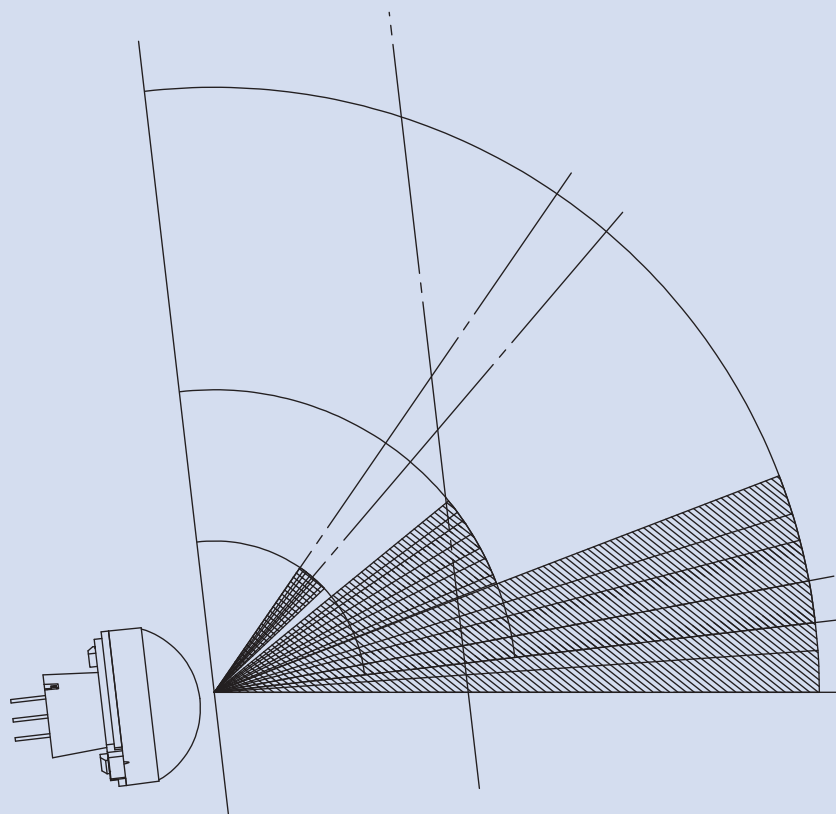

Q1-18

Does airflow around the sensor have any influence on detection performance?

No, unless the airflow is blown directly across the lens or directly at the sensor. The principle of operation of the sensor is to detect changes in the amount of infrared energy.

$$\text{Infrared energy} = \text{Temperature} \times \text{Emissivity of the object}$$

Therefore, because air is 0% emissivity, the sensor does not respond no matter how much the temperature changes.

However, when the airflow blows directly toward the sensor's lens causing the temperature of the lens itself to change, there is the possibility of a false trigger. In addition, if the airflow changes the background temperature rapidly, the sensor may be sensitive enough to interpret this as warm body movement.

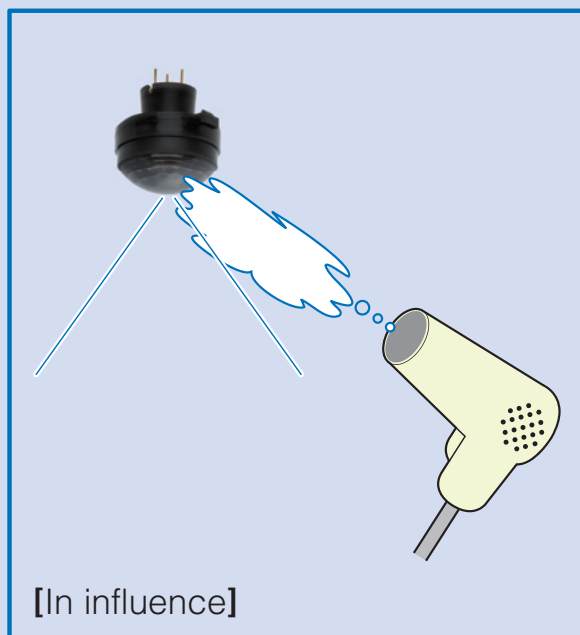
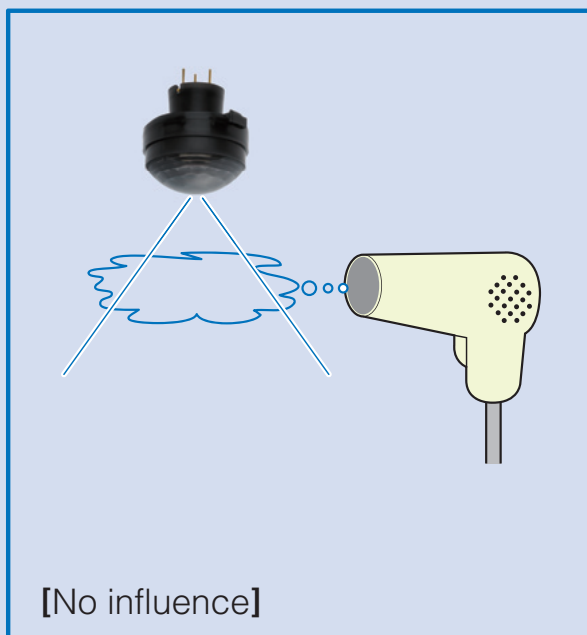

Q2-1

How should the sensor be wired?

- Below are the functional pin assignments:
 Vdd power source (+)
 GND power source (-)
 Out output terminal
- Connect the pins as follows:
 - Connect the (+) terminal of the power source to Vdd.
 - Connect the (-) terminal of the power source to GND.
- Select an output resistor in accordance with Vout.

1) Digital output type

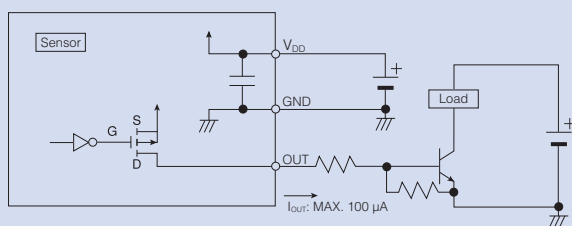

2) Analog output type

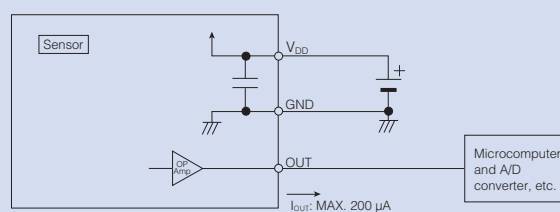

Q2-2

Can the circuit stabilization time (wait time) be shortened?

No, it cannot.

The circuit stabilization time is the time required for the internal circuit to stabilize after the power is turned on.

During this time accurate detection cannot take place as the output is unstable.

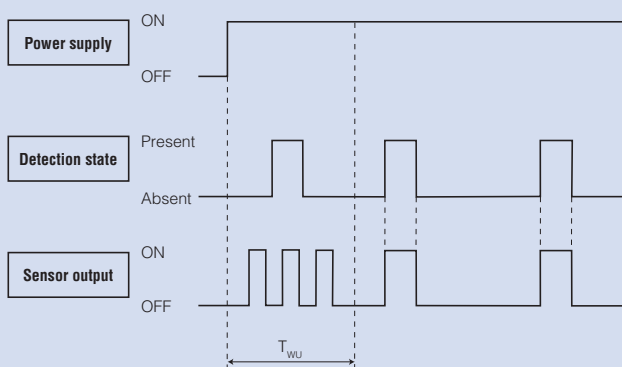

Operating principle, usage related

Electrical connection, output signal related

Q2-3

Can the AC load be turned on and off directly?

No, it cannot.

A mechanical relay or solid state relay should be connected to the output of the infrared sensor to turn the AC load on or off.

If a timer is needed, please refer to Q2-6 for an example of a timer circuit.

Circuit example

Circuit example as bellows.

1. For mechanical relay drive

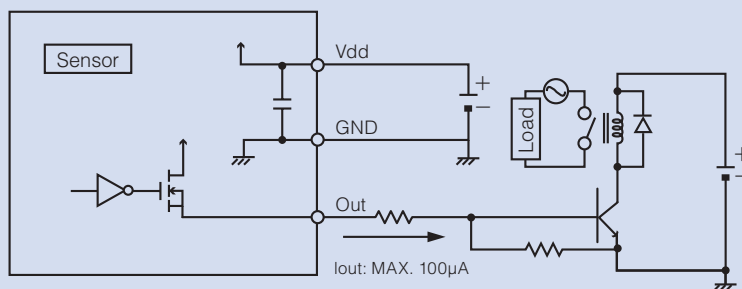

Related to product specifications, etc.

Q2-4

Are there any sensors with an operating voltage of 12V DC or 24V DC?

No, there are not.

A regulator or other circuitry should be used to transform the voltage to 5V DC.

Q2-5

Is it possible to design a common circuit for multiple sensors?

Yes, it is.

A design using parallel connections such as in the example below can be used.

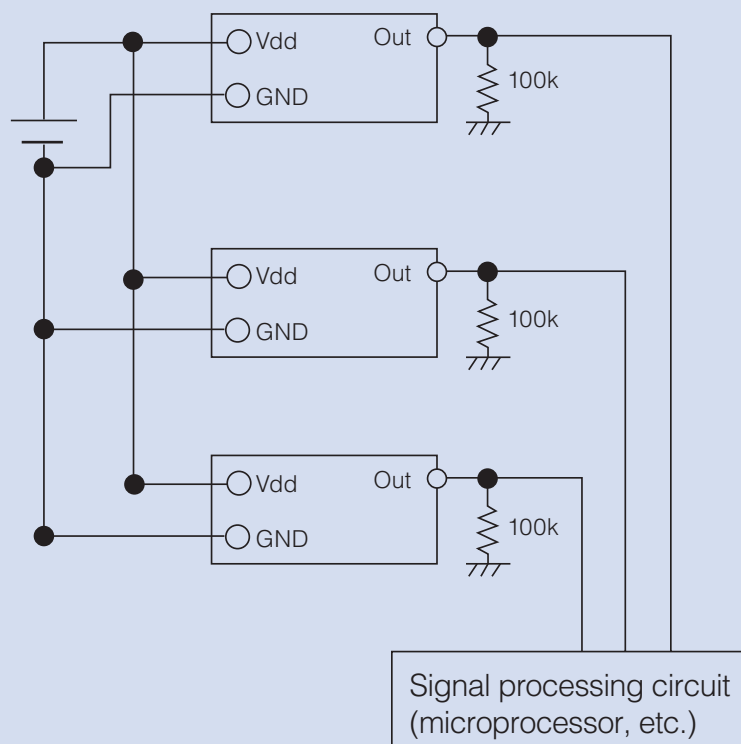

Q2-6

How do I set a timer for the output?

You can set the microprocessor's timer function. If the device does not have such a function, refer to the following circuit image below to create a timer as an example.

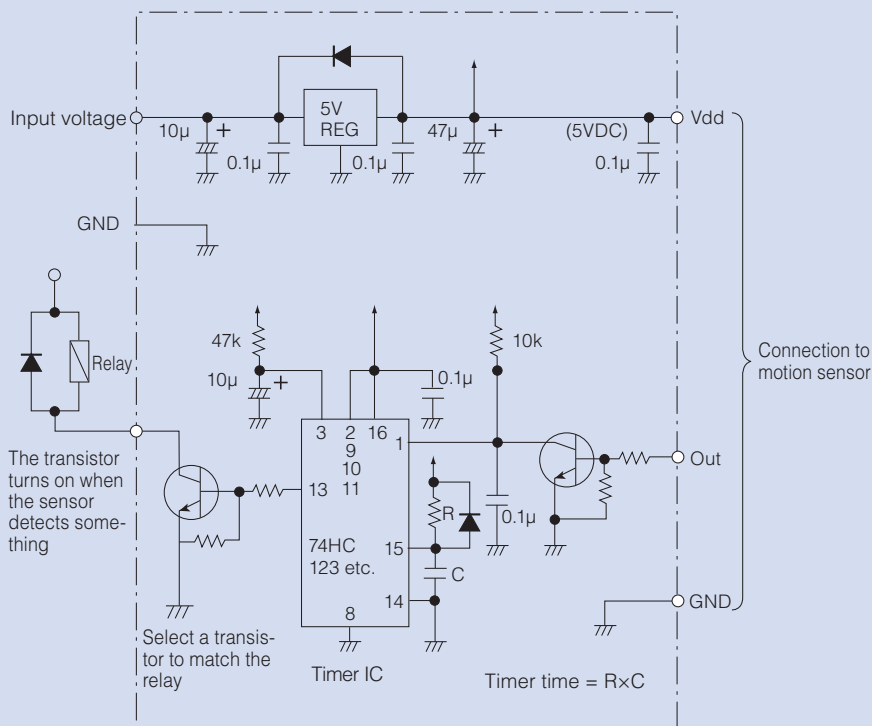

Note 1) Each timer IC manufacturer required different values for the resistance (R) and capacitance (C) used for the time setting. Please confirm with the manufacturer for these values before you design the circuit.

Note 2) This is the reference circuit which drives the motion sensor. Please note that Panasonic bears no responsibility for any damages or loss arising from the use of this circuit. A noise filter should be installed for applications requiring enhanced detection reliability and noise withstanding capability.

Q2-7

Does the performance change depending on the operating voltage?

The detection performance does not change.

Operating principle, usage related

Electrical connection, output signal related

Related to product specifications, etc.

Q2-8 What is the duration for the digital output signal during a detection?

It is depends on certain conditions.
Therefore, it cannot be specified.

Detection occurs when the sensor generates an analog signal that extends beyond its threshold values. The slope of this analog signal can ramp drastically or minimally due to the detected change in temperature or movement speed of the object.

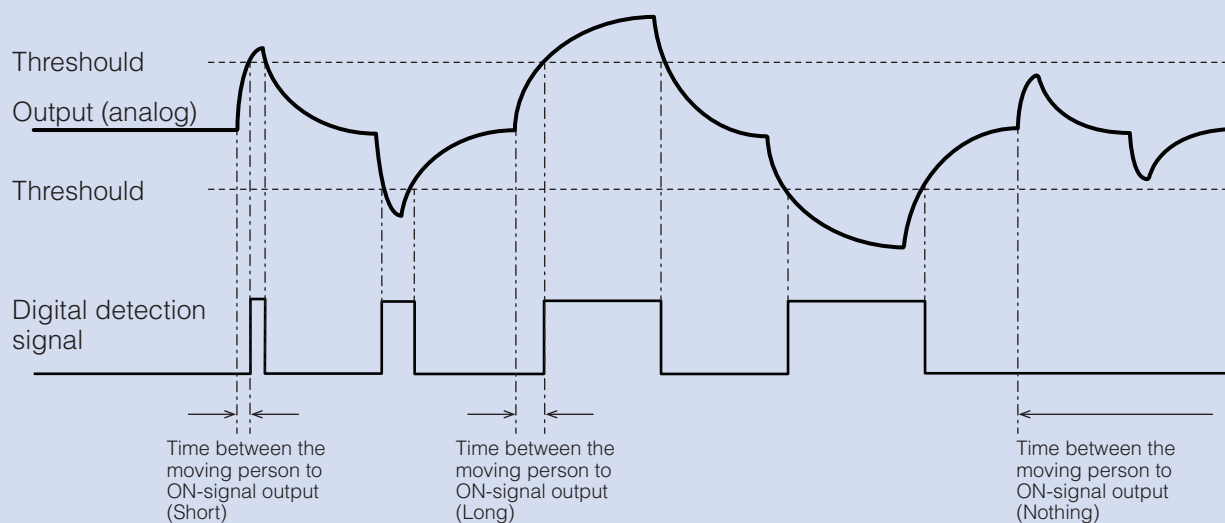

Q2-9

If a person keeps moving in the detection area, what kind of output appears from the digital output type sensor?

The output would be a repetition of ON/OFF.

When the detection state persists, the pyroelectric elements output an analog signal waveform continuously. The output analog signal is amplified by an amplifier circuit and when it exceeds the preset voltage level threshold, the sensor interprets this as motion by converting the signal to a digital ON output.

As the analog signal drops below the voltage threshold, the digital signal goes back to an OFF signal as the output.

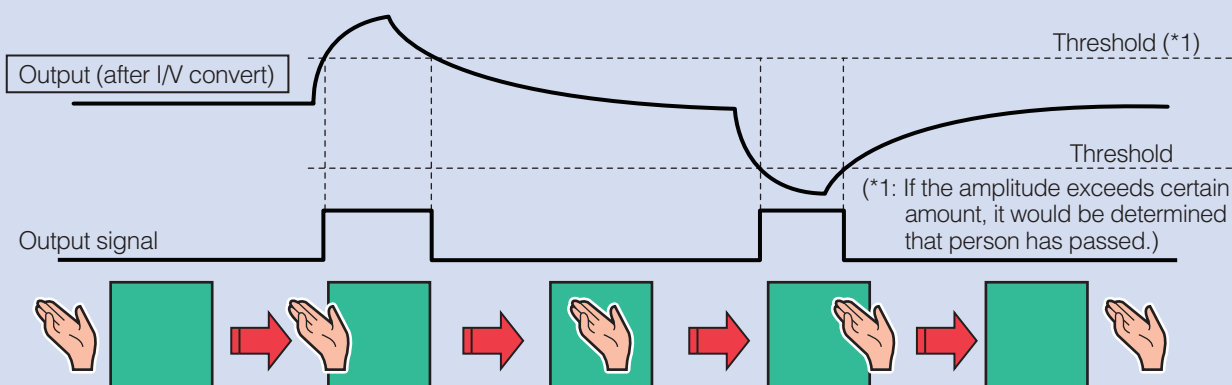

Operating principle, usage related

Electrical connection, output signal related

Related to product specifications, etc.

Q2-10 What is the duration of the digital output signal from the sensor after a detection?

More than 1ms.

The pyroelectric elements' output differs depending on the temperature difference between the object and its surroundings as well as the moving object's speed. The output is amplified by an amplifier, and if the amplified output exceeds the reference voltage, the sensor interprets this as a detection by converting the analog signal to a digital ON output signal.

Although the output time is not always the same, the signal is more than 1ms due to the circuit characteristics.

Q2-11 How much time elapses after the person stops moving within the detection area and before the signal becomes a "definite" OFF?

It cannot be specified because it depends on too many parameters. It may take some time to turn off depending on the conditions.

Q2-12 Why doesn't the sensor have a timer circuit for setting the output time?

It has become common practice to use the timer function of a microprocessor on the main board, so Panasonic infrared sensors do not implement it. If you wish to see an example of a timer circuit, refer to Q2-6.

Q2-13

Can the sensor handle external surges and electrical noise?

Yes it can handle external surges to a certain extent. It depends on the quality of the power supply and the noise conditions of the surrounding environment such as noise amplitude, noise frequency and cable routing.

In principle, the sensor should be used in a low noise environment.

Reference: The sensor is not affected by mobile phone noise with a minimum distance of 5 centimeters.

Operating principle, usage related

Q2-14

What is a comparator?

The amount of infrared radiation emitted from the human body is very small and the signal cannot be processed by the circuit as is.

For this reason, the signal is amplified by an internal amplifier circuit. The amplified signal must be compared to a preset reference level.

If the amplified circuit is greater than the reference level, a person is considered to have entered the detection area and a digital ON signal is outputted.

The circuit that makes this comparison is called a comparator.

Electrical connection, output signal related

<Timing chart> ● Standard type

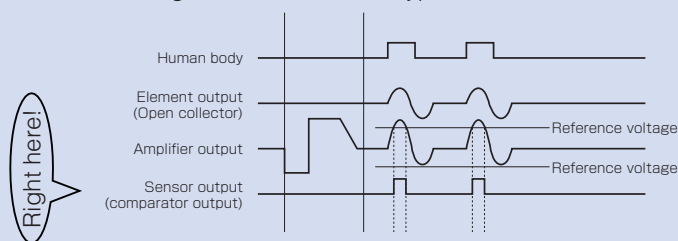

Related to product specifications, etc.

Q2-15

What are sleep mode, standby mode, and mask mode?

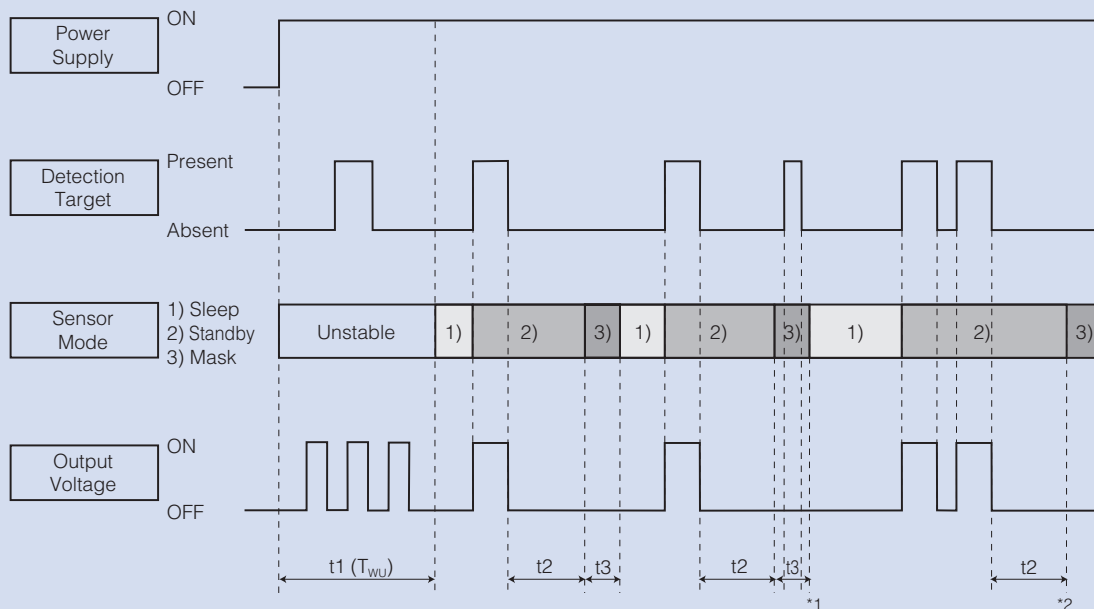

[Modes]

- 1) Sleep Mode: When the output is OFF. The electrical current consumption during sleep mode is around $1\mu A$.
- 2) Standby Mode: After the sensor's output reaches ON status, the sensor switches to standby mode. The electrical current consumption gets close to $1.9\mu A$. When the sensor's output returns to its OFF value after expiration of the "hold time", the sensor switches again to sleep mode.
- 3) Mask Mode: Time during which the output is forced to OFF after the end of the standby mode. (No detection is possible during this period.)

[Durations]

- $t_1(T_{wu})$: Circuit Stability Time About 25s. (typ.)
During this stage, the output's status is undefined (ON/OFF) and detection is therefore not guaranteed.
- t_2 : Standby Hold Time About 2.6s (typ.)
Depending on the number of output happening during standby mode, the hold time can differ. (*1)
- t_3 : Mask Time About 1.3s (typ.)
During this stage, even if the sensor detects something, output will not switch to ON (*2)

According to our research

Q2-16

How to reinforce power source noise?

A capacitor can be added as seen in the example below.

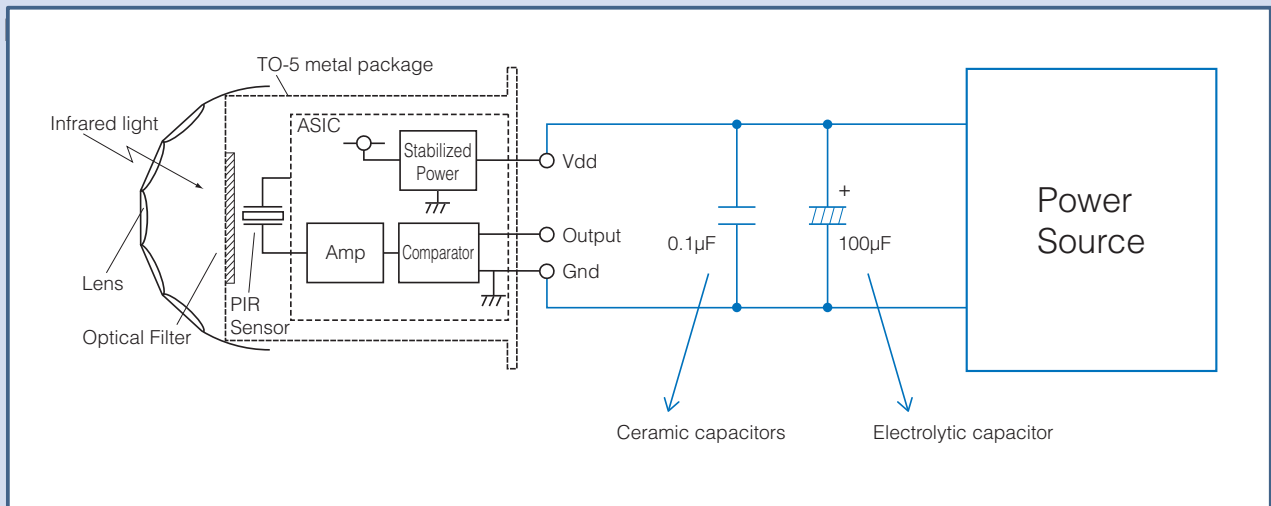

Operating principle, usage related

Electrical connection, output signal related

Related to product specifications, etc.

Q2-17

What is the operating process for output current?

PaPIRs have a voltage output (Out) which can only drive a certain current. The digital sensors can drive a maximum of 100 μ A, whereas the analog sensors (EKMC26-series) can drive up to 200 μ A.

The user must consider & design the circuit connected to the voltage output so that the specified maximum output current is not exceeded.

Otherwise the sensor shows unstable behavior and in the worst case can be damaged if this value is exceeded.

Panasonic infrared sensors do not work if more than 100 μ A is output.

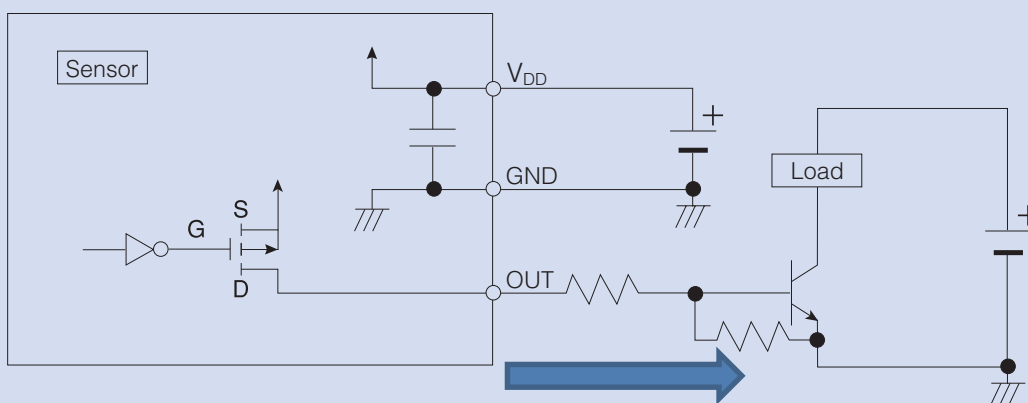
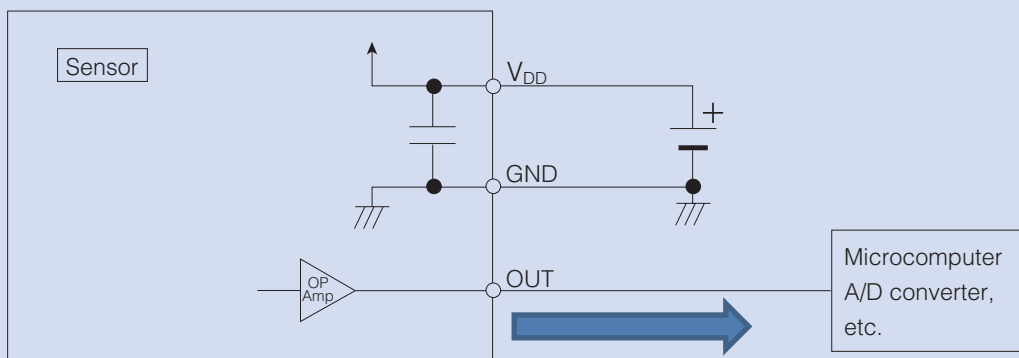

Operating principle, usage related

Electrical connection, output signal related

Related to product specifications, etc.

Q3-1**Will the sensor detect anything beyond the “maximum distance” specified in the catalog?**

There is a possibility of detection.

This sensor is specified to detect an object based on defined conditions.

The catalogue is written as “Standard detection type 5m” and “Slight motion detection type 2m”, which is our “guaranteed detection distance”.

In reality, the detection cases may differ depending on the following factors.

- Temperature difference between target object and surroundings.
- Size of target object and how it overlaps with the detection zones.
- Moving speed of target object.

Therefore, there is the possibility that the sensor detects something beyond the specified “maximum distance”.

In addition, depending on the conditions, there is even the possibility that the sensor may not detect even within the specified detection distance.

Q3-2

How is the detection area of Panasonic infrared sensors determined?

- Detection zone

This is the area where people are detected. There are 4 heat receiving elements inside the sensor, and those elements are projected to the lens creating 4 detection zones per each facet of the lens.

- Detection area

Detection area is where the 4 detection zones are as one group. This is a set of detection zones projected by a single facet on the lens.

- Detection range/distance

If ceiling mounted - Detection range / distance is the installation height that the sensor will detect reliably as per specification.

If wall mounted - Detection range / distance that the sensor will detect reliably.

One pyroelectric element inside PaPIRs is projected in various directions by a lens.

→ The detection area is configured.

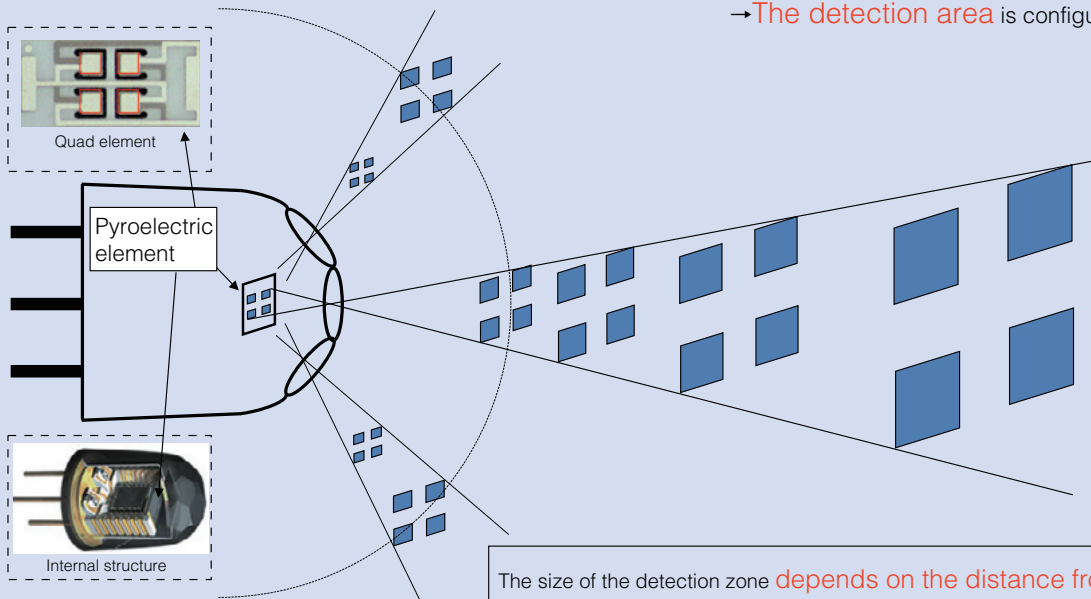

X-Y sectional view (3m)

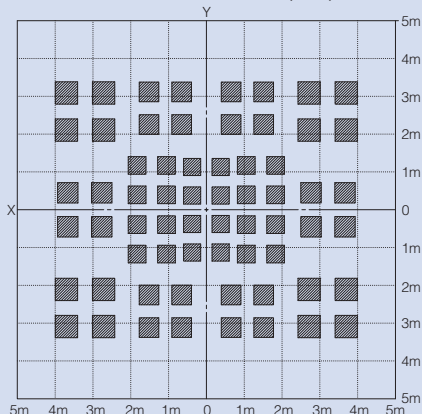

Detection area

The standard type of PaPIRs (EKMC160111*) consists of 16 lens facets of 5 different shapes. The sensor is composed of 64 detection zones (4 detection zones x 16 lenses).

*Color of lens

Operating principle, usage related

Electrical connection, output signal related

Related to product specifications, etc.

Q3-3

What does “temperature difference of 4°C or more against background” mean?

PaPIRs are able to function based on a temperature difference of 4°C between a heat source such as a person and the background such as a floor or wall.

The background is the environmental temperature such as the area around the ground, walls and ceiling. When the person enters detection range of the sensor, the temperature difference between the ambient temperature and object will be detected due to the sensing of change in infrared light.

(Reference date) Wearing long-sleeve work clothes

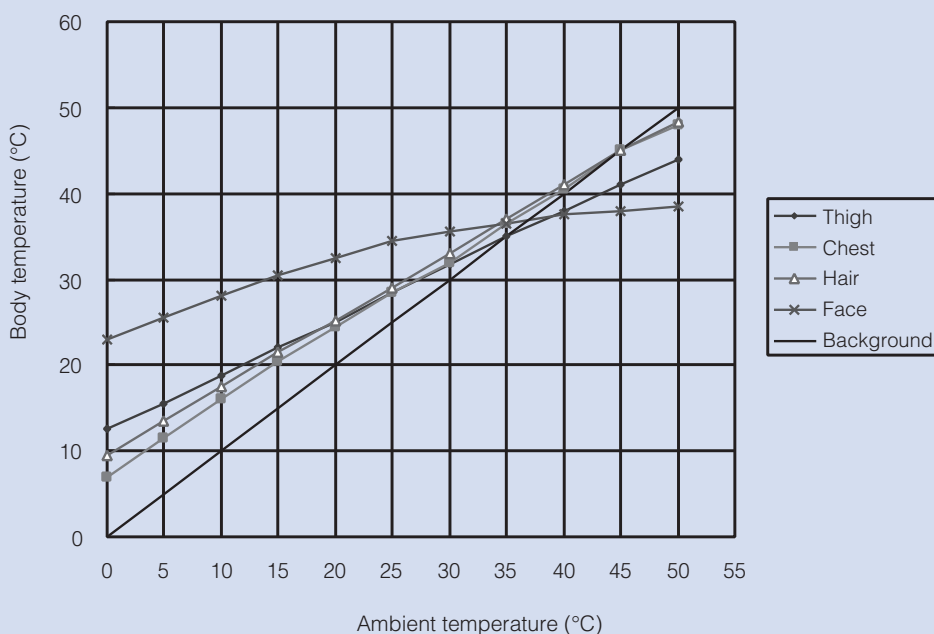

According to our research

Q3-4 How is product life cycle calculated?

Product life is estimated by an accelerated reliability test based on a THB (Temperature, Humidity and Bias) test.

Using this evaluation method, we established that there is no problem storing the sensor indoors at normal temperatures and humidity for 5 years.

The quality guarantee period is one year.

Operating principle, usage related

Q3-5 What is the TO-5 metal package?

TO-5 is a standard for package size for semiconductors.

As seen in this image, a TO-5 package consists of a metal semiconductor chip mounting 9mm in a diameter, a dish-shaped component called “stem” that holds the external leads, and metal cap that covers the semiconductor chip.

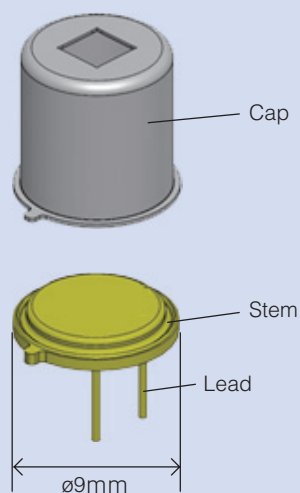

Electrical connection, output signal related

Related to product specifications, etc.

Q3-6 Is it possible to use reflow soldering?

No, it is impossible.

Q3-7

How can we confirm detection performance based on the specification?

The design concept requires that the target object to be detected completely passes through the detection zone.

The conditions are as follows.

- Size of detection target.
- Movement speed of detection target.
- Temperature of detection target. (temperature difference from surroundings)
- Distance between the target and the sensor

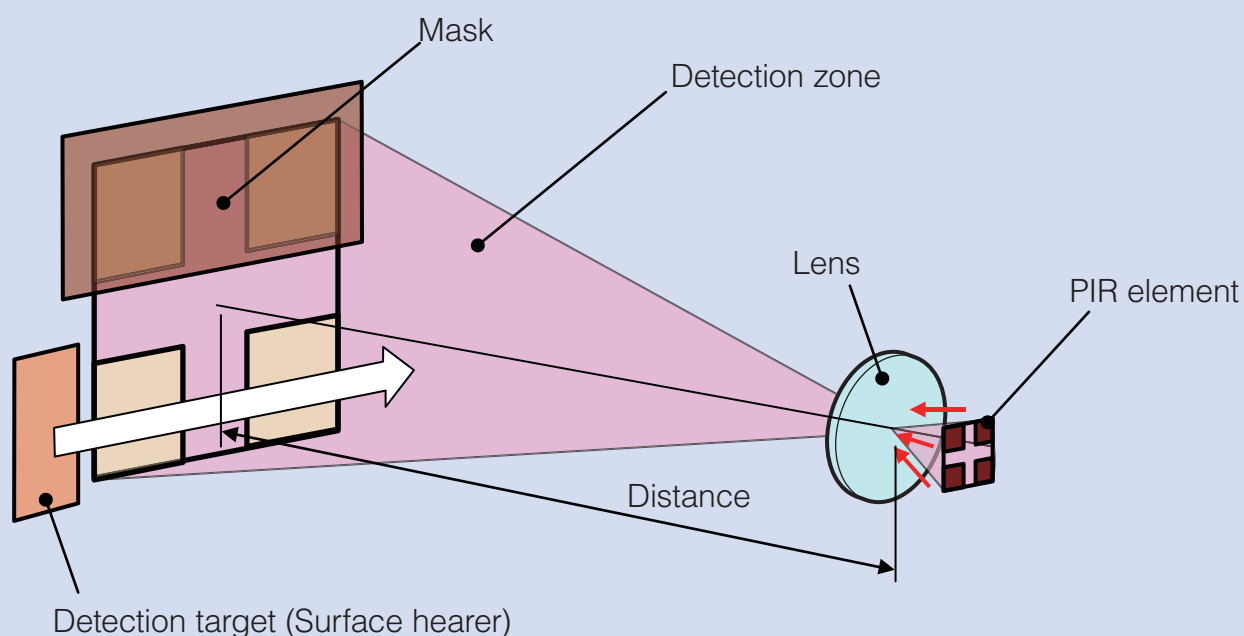

Operating principle, usage related

Electrical connection, output signal related

Related to product specifications, etc.

Q3-8 Is there any correlation between sensitivity and distance?

Yes, there is.

Sensitivity is inversely proportional to the size of the detection zone.
 (The larger the detection zone, the more difficult it is to detect the object.)

The sensitivity is roughly inversely proportional to the square of the distance as defined by the Inverse Square Law.

The greater the distance, the larger the individual detection zones become. Larger detection zones reduce the sensitivity against small objects or small movements.

One pyroelectric element inside PaPIRs is projected in various directions by a lens.

→ The detection area is configured.

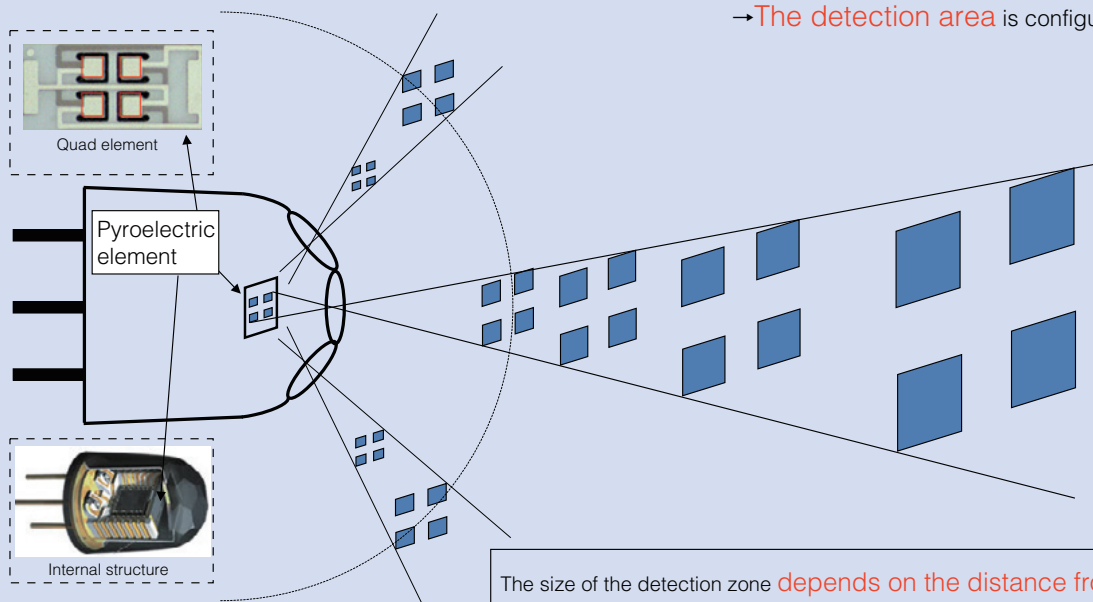

The size of the detection zone depends on the distance from PaPIRs
 = Zone size increases as the distance increases.

X-Y sectional view (3m)

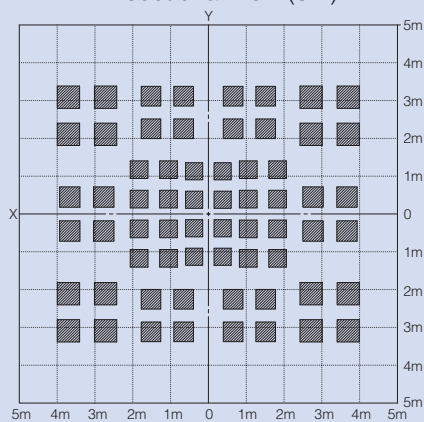

Detection area

The standard type of PaPIRs (EKMC160111*) consists of 16 lens facets of 5 different shapes. The sensor is composed of 64 detection zones (4 detection zones x 16 lenses).

*Color of lens

Operating principle, usage related

Electrical connection, output signal related

Related to product specifications, etc.

Q3-9

What is NEP (Noise Equivalent Power)?

This amount indicates the incident energy intensity when the noise and signal output are equal.

The smaller this value is, the higher the detection capability which means that the noise level is reached with less light incident.

NEP = Noise Equivalent Power

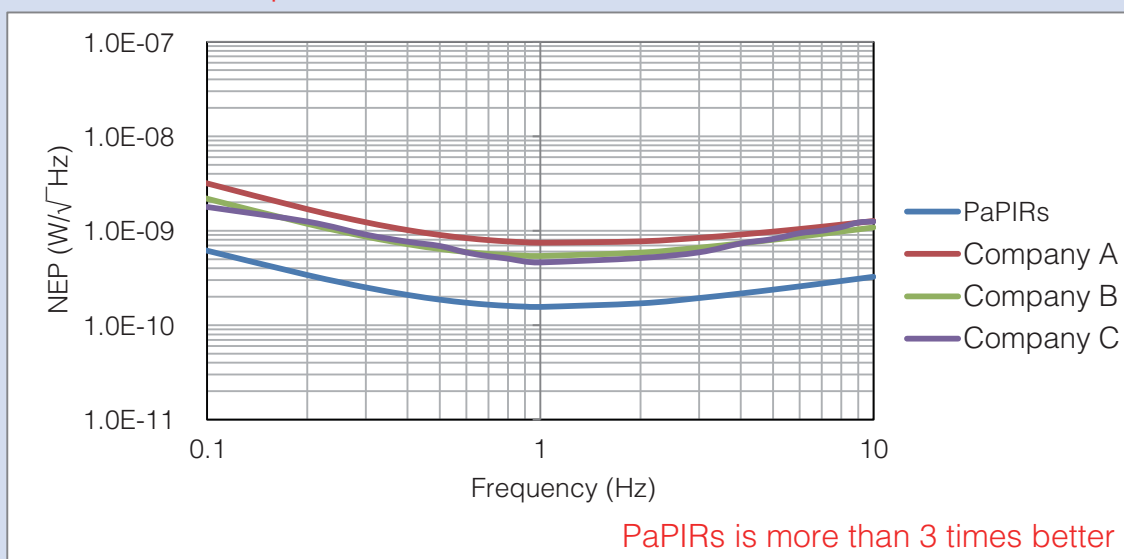

PaPIRs is more than 3 times better

According to our research

Operating principle, usage related

Electrical connection, output signal related

Related to product specifications, etc.

Q3-10

What is D* (ratio of detection performance)?

D* This is an index that component of the light receiving area is reflected in NEP. It indicates the sensor detection performance as actual product.

D* = Detection capability

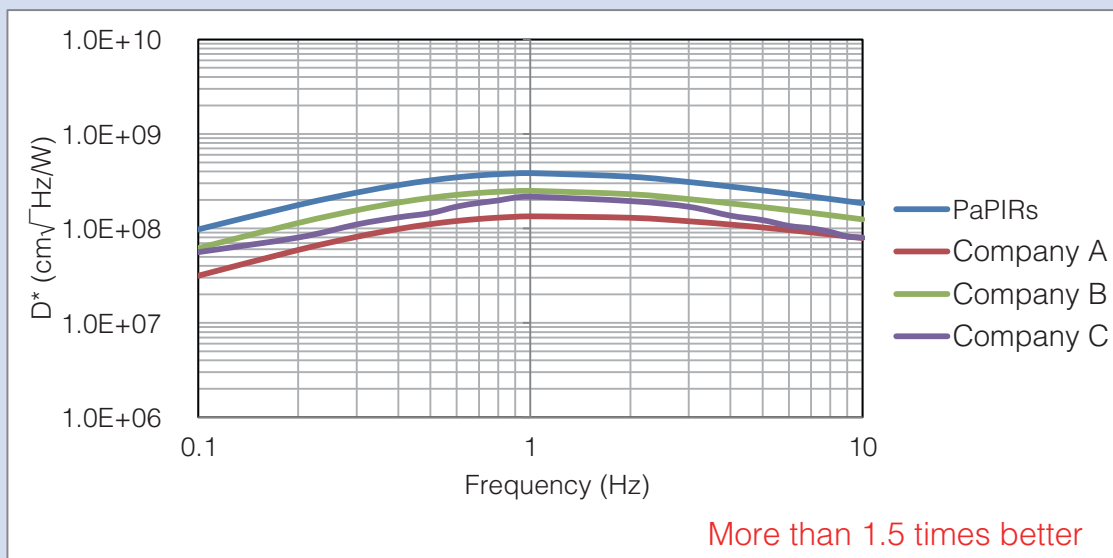

According to our research

Panasonic has better detection performance even though the sensor has a smaller element compared to other solutions.

Element	PaPIRs	Company A	Company B	Company C
Size (mm)	0.6 × 0.6	2.6 × 0.7	1.0 × 1.0	1.0 × 1.0

Operating principle, usage related

Electrical connection, output signal related

Related to product specifications, etc.