

D2JW-AQ

Sealed Subminiature Basic Switch

Ultra-small and Highly Sealed

- Degree of protection conforms to JIS Waterproof standard and IEC IP67.
(Excluding the terminals on terminal models)
- Wide range of operating temperatures from -40°C to +85°C.
- Gold-alloy crossbar contact and coil spring offer long durability and high contact reliability.

RoHS Compliant



Model Number Legend

D2JW-01 1 2 3 -AQ

1. Actuator

- None : Pin plunger
- K1A : Short hinge lever
- K1 : Hinge lever
- K2 : Hinge roller Lever
- K3 : Simulated roller hinge lever

2. Contact form





- 1: SPDT
- 2: SPST-NC (Molded lead wire models only)
- 3: SPST-NO (Molded lead wire models only)

3. Terminals

- None : Solder terminals
- MD : Molded lead wires

List of Models

Due to the idiosyncrasies of the automotive parts industry, a business decision is required on individual items to determine when to start supply. Contact your OMRON representative for information on individual models.

Actuator	Terminals	Contact form	Model
Pin plunger 	Solder terminals	SPDT	D2JW-011-AQ
		SPDT	D2JW-011-MD-AQ
	Molded lead wires	SPST-NC	D2JW-012-MD-AQ
		SPST-NO	D2JW-013-MD-AQ
Short hinge lever 	Solder terminals	SPDT	D2JW-01K1A1-AQ
		SPDT	D2JW-01K1A1-MD-AQ
	Molded lead wires	SPST-NC	D2JW-01K1A2-MD-AQ
		SPST-NO	D2JW-01K1A3-MD-AQ
Hinge Lever Models 	Solder terminals	SPDT	D2JW-01K11-AQ
		SPDT	D2JW-01K11-MD-AQ
	Molded lead wires	SPST-NC	D2JW-01K12-MD-AQ
		SPST-NO	D2JW-01K13-MD-AQ
Hinge Roller Lever Models 	Solder terminals	SPDT	D2JW-01K21-AQ
		SPDT	D2JW-01K21-MD-AQ
	Molded lead wires	SPST-NC	D2JW-01K22-MD-AQ
		SPST-NO	D2JW-01K23-MD-AQ
Simulated Roller Hinge Lever Models 	Solder terminals	SPDT	D2JW-01K31-AQ
		SPDT	D2JW-01K31-MD-AQ
	Molded lead wires	SPST-NC	D2JW-01K32-MD-AQ
		SPST-NO	D2JW-01K33-MD-AQ

Contact form

● SPDT

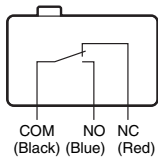

● SPST-NC

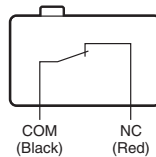

● SPST-NO

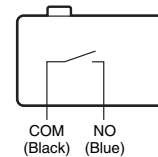

The color in parentheses indicates the color of the lead wire.

Contact Specifications

Contact	Specification	Crossbar
	Material	Gold alloy
	Gap (standard value)	0.5 mm
Inrush current	NC	0.1A max.
	NO	0.1A max.
Minimum applicable load (see note)		5 VDC 1 mA

Ratings

Rated voltage	Resistive load
30 VDC	0.1A

Note. The above rating values apply under the following test conditions.

- (1) Ambient temperature: 20±2°C
- (2) Ambient humidity: 65±5%
- (3) Operating frequency: 30 operations/min

Characteristics

Permissible operating speed	1 mm to 250 mm/s (for pin plunger models)	
Permissible operating frequency	Mechanical	240 operations/min
	Electrical	30 operations/min
Insulation resistance	100 MΩ min. (at 500 VDC with insulation tester)	
Contact resistance (initial value)	Solder terminal models	100 mΩ max.
	Molded lead wire models	140 mΩ max.
Dielectric strength * 1	Between terminals of the same polarity	600 VAC 50/60 Hz 1min
	Between current-carrying metal parts and ground	1,000 VAC 50/60 Hz 1min
	Between each terminal and non-current-carrying metal parts	1,000 VAC 50/60 Hz 1min
Vibration resistance * 2	Malfunction	10 to 55 Hz, 1.5 mm double amplitude
Shock resistance	Durability	1,000 m/s ² {approx. 100G} max.
	Malfunction * 2	200 m/s ² {approx. 20G} max.
Durability * 3	Mechanical	1,000,000 operations min. (60 operations/min)
	Electrical	100,000 operations min. (30 operations/min)
Degree of protection	Solder terminal models	IEC IP67 (excluding the terminals on terminal models)
	Molded lead wire models	IEC IP67
Ambient operating temperature	-40°C to +85°C (at ambient humidity of 60% max.) (with no icing or condensation)	
Ambient operating humidity	35% to 98% (for +5°C to +35°C)	
Weight	Approx. 0.6g (for pin plunger models with terminals)	

Note. The data given above are initial values.

- *1. The dielectric strength values shown apply for use with Separator (refer to **page 48**).
- *2. For the pin plunger models, the above values apply for use at the free position and total travel position. For the lever models, they apply at the total travel position. Close or open circuit of the contact is 1ms max.
- *3. For testing conditions, consult your OMRON sales representative.

Mounting Holes (Unit: mm)

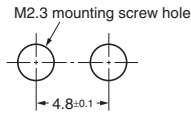

Dimensions (Unit: mm) / Operating Characteristics

Dimensions and operating characteristics of other actuator models for lead wire models are omitted in the illustration below, as the dimensions other than the terminal part and operating characteristics is common with Solder terminal models.

● Pin plunger models D2JW-01K1-AQ

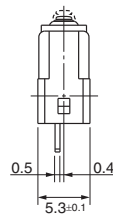
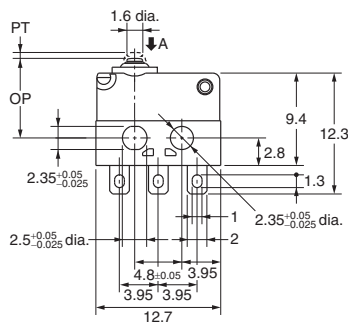
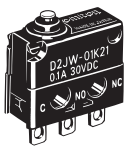

Operating characteristics

Operating Force	OF Max.	2.45 N {250 gf}
Releasing Force	RF Min.	0.98 N {100 gf}
Pretravel	PT Max.	0.6 mm
Overtravel	OT Min.	0.3 mm
Movement Differential	MD Max.	0.1 mm
Operating Position	OP	8.1±0.3 mm

● Short hinge lever models D2JW-01K1A1-AQ

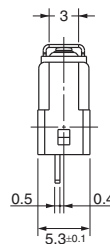
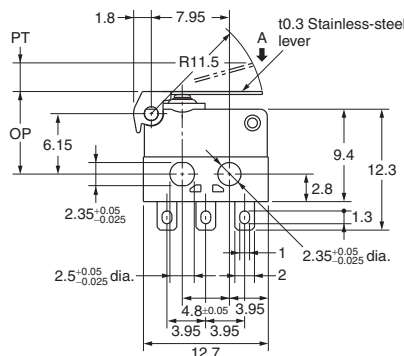

Operating Force	OF Max.	1.15 N {117 gf}
Releasing Force	RF Min.	0.23 N {23 gf}
Pretravel	PT Max.	5.4 mm
Overtravel	OT Min.	0.7 mm
Movement Differential	MD Max.	0.5 mm
Operating Position	OP	8.4±0.8 mm

Note 1. Unless otherwise specified, a tolerance of ±0.4 mm applies to all dimensions.
 Note 2. The operating characteristics are for operation in the A direction (↓).

●Hinge lever models D2JW-01K11-AQ

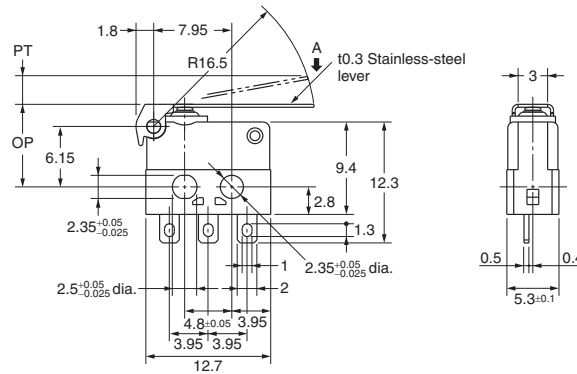
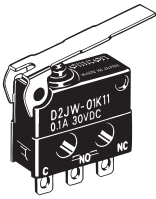

Operating Force	OF Max.	0.80 N {82 gf}
Releasing Force	RF Min.	0.15 N {16 gf}
Pretravel	PT Max.	6.4 mm
Overtravel	OT Min.	1.4 mm
Movement Differential	MD Max.	0.7 mm
Operating Position	OP	8.4±0.8 mm

●Simulated roller lever hinge models D2JW-01K31-AQ

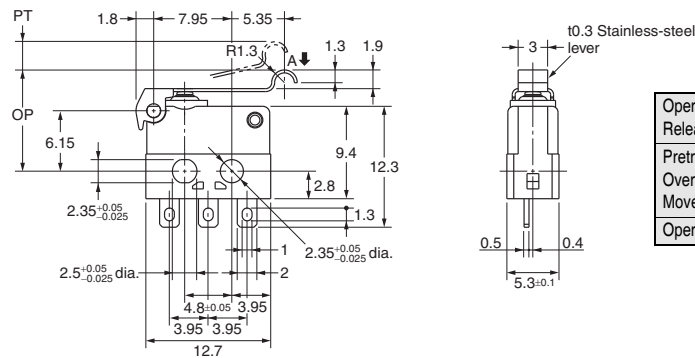
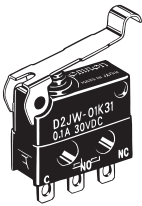

Operating Force	OF Max.	0.95 N {97 gf}
Releasing Force	RF Min.	0.19 N {20 gf}
Pretravel	PT Max.	5.5 mm
Overtravel	OT Min.	1.1 mm
Movement Differential	MD Max.	0.6 mm
Operating Position	OP	10.3±0.8mm

●Hinge roller lever models D2JW-01K21-AQ

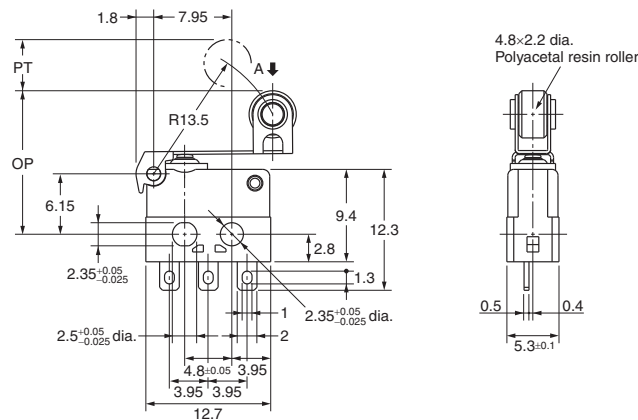
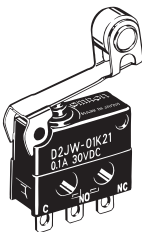

Operating Force	OF Max.	0.98 N {100 gf}
Releasing Force	RF Min.	0.19 N {20 gf}
Pretravel	PT Max.	5.2 mm
Overtravel	OT Min.	1.1 mm
Movement Differential	MD Max.	0.5 mm
Operating Position	OP	14.6±0.8 mm

●Molded lead wire models D2JW-01□□□-MD-AQ

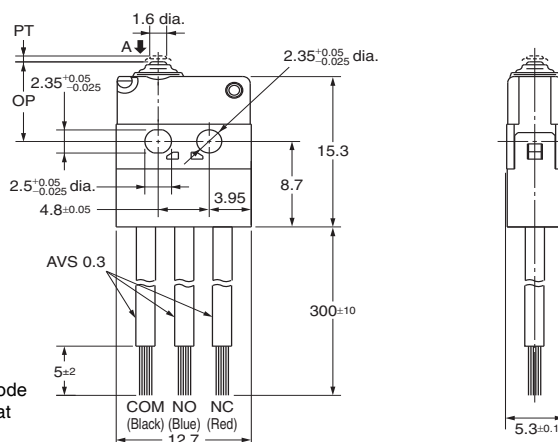
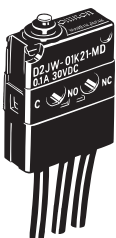

Operating Force	OF Max.	2.45 N {250 gf}
Releasing Force	RF Min.	0.98 N {100 gf}
Pretravel	PT Max.	0.6 mm
Overtravel	OT Min.	0.3 mm
Movement Differential	MD Max.	0.1 mm
Operating Position	OP	8.1±0.3 mm

Note. When ordering, replace □ with the code for the actuator and contact form that you need.

Note 1. Unless otherwise specified, a tolerance of ±0.4 mm applies to all dimensions.
Note 2. The operating characteristics are for operation in the A direction (↓).

Precautions

Please refer to "Safety Precautions for All Detection Switches" on page 15 for correct use.

Cautions

●Terminal Connection

Before soldering the lead wire to the terminal, first insert the lead wire conductor through the terminal hole.

Complete the soldering at the iron tip temperature till 250°C within 3 seconds, and do not apply any external force for 1 minute after soldering. Soldering at an excessively high temperature or soldering for more than 3 seconds may deteriorate the characteristics of the Switch.

●Degree of Protection

- The Switch was tested and found to meet the conditions necessary to meet the following standard given below. The test checks for water intrusion after immersion for a specified time period, not for switching operation underwater.

JIS C0920:

Degrees of protection provided by enclosures of electrical apparatus (IP Code)

IEC 60529:

Degrees of protection provided by enclosures (IP Code)

Degree of protection: IP67

(check water intrusion after immersion for 30 min. submerged 1m underwater)

●Protection Against Chemicals

Prevent the Switch from coming into contact with oil or chemicals.

Otherwise, damage to or deterioration of Switch materials may result.

Correct Use

●Mounting

Use M2.3 mounting screw with plane washers or spring washers to securely mount the Switch. Tighten the screws to a torque of 0.20 to 0.29 N·m {2 to 3 kgf·cm}.

●Wiring Molded Lead Wire Models

When wiring molded lead wire models, ensure that there is no weight applied on the wire and that the wire is not bent. Otherwise, damage to the Switch or deterioration in the sealing may result.

●Using Micro Loads

Even when using micro load models within the operating range shown below, if inrush/surge current occurs, it may increase the contact wear and so decrease durability. Therefore, insert a contact protection circuit where necessary.

Separator (sold separately)

SEPARATOR FOR D2JW

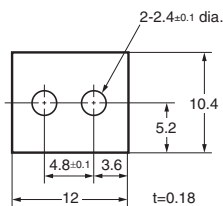

Note. The material of the separator is EAVTC (epoxy alkylid/ varnish tetron cloth).