

Sensors Selector Guide

OMRON's unique sensing technology responds to users' evolving needs.

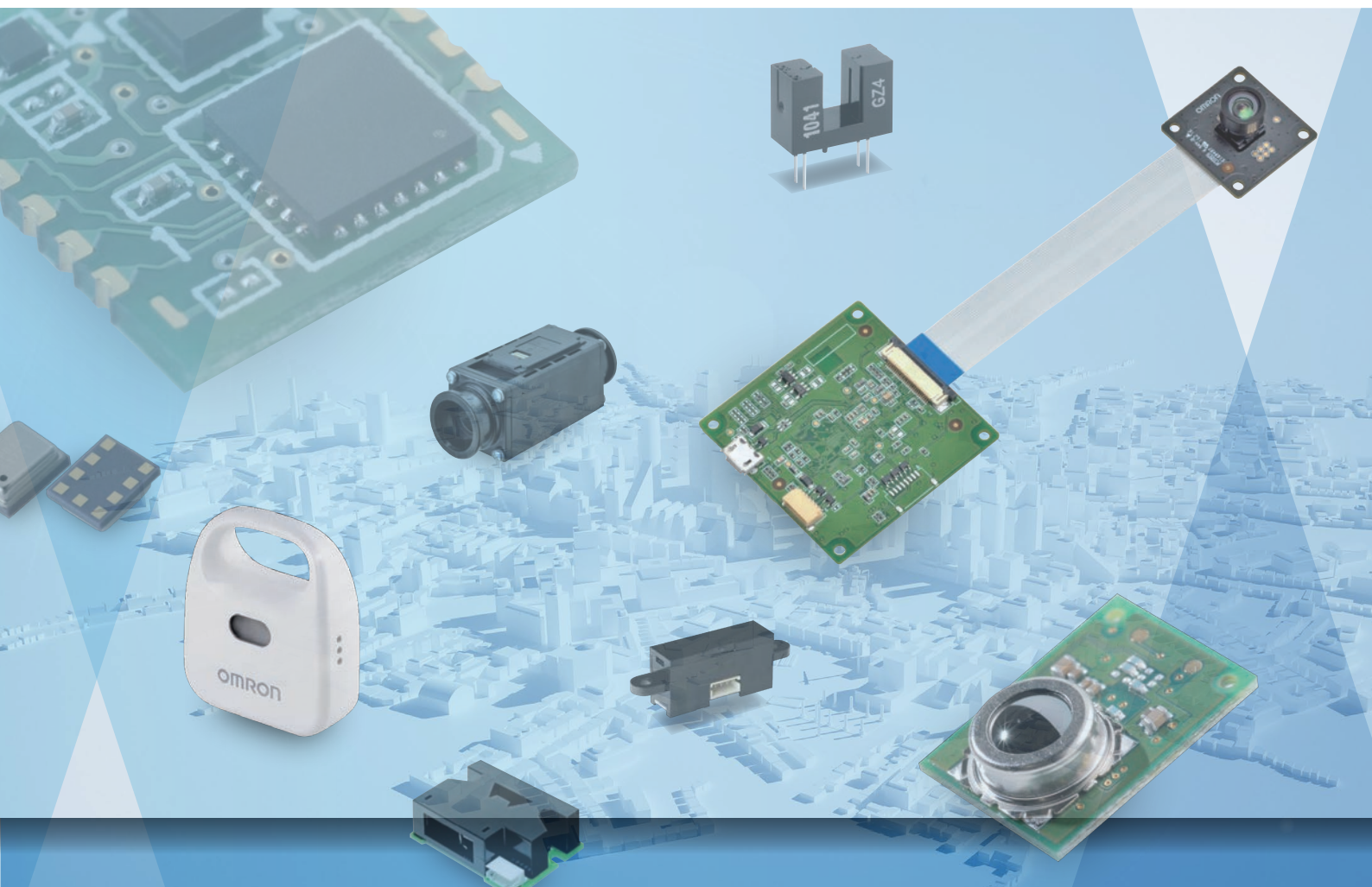

Analysis algorithm technology

- Human vision sensing technologies
- Seismic detection

Optical design technology

- Object presence/absence
- Displacement
- Distance

MEMS technology

- Temperature
- Pressure
- Flow rate

OMRON's human-friendly sensing technology helps build a safe and comfortable society.

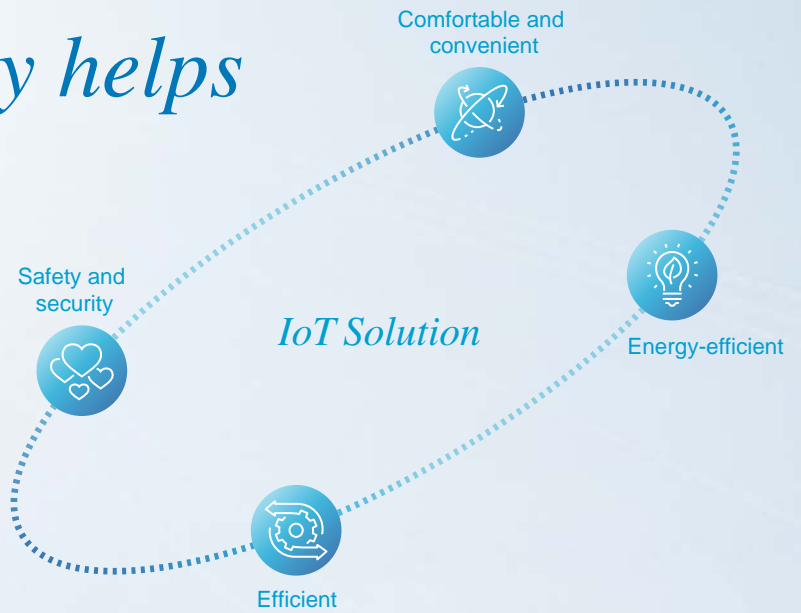

OMRON's sensing technology meets users' evolving needs.

Technology

Analysis algorithm technology

- Human image sensing technologies
- Earthquake detection



OKAO® Vision (Software)



Human Vision Components (Module)











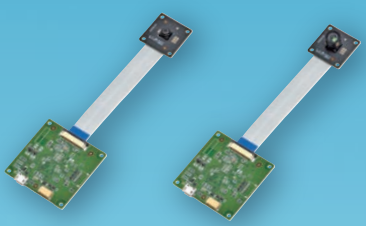

Seismic Sensor

* The OKAO® name and logo are registered trademarks or trademarks of OMRON Corporation in Japan and other countries.

Human Sensing



Embedded-type Human Vision Components

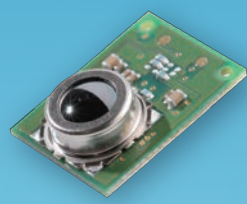

-  Face detection
-  Mr. Alex Face recognition
-  happiness Expression estimation
-  age 25 Age estimation
-  male Gender estimation
-  Right 30° Face Direction estimation
-  Gaze estimation
-  Body detection
-  Hand detection
-  Blink estimation

MEMS Thermal Sensor



-  Position of people
-  Number of people

Condition Sensing

Air Quality Sensor

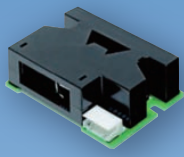

-  Dust

MEMS Flow Sensor



-  Airflow

Seismic Sensor

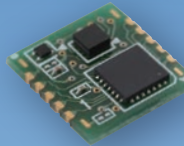

-  Earthquake

MEMS Thermal Sensor



-  Temperature

Light Convergent Reflective Sensor



-  Object presence/absence

MEMS Barometric Pressure Sensor

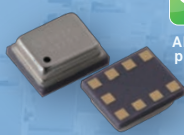

-  Absolute pressure







Photomicrosensor



-  Object presence/absence

Environment Sensor



-  Temperature
-  Humidity
-  Absolute pressure
-  Light
-  Noise
-  UVI

Optical design technology

- Object presence/absence
- Displacement
- Distance



MEMS technology

- Humidity
- Flow rate
- Pressure

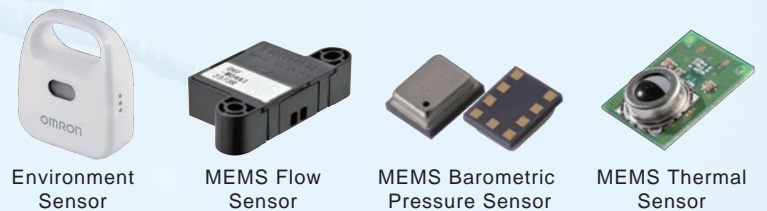

Photomicrosensor EE-S

Ordering Information

Model *1	EE-SX1320 /4320	EE-SX1321	EE-SX1330	EE-SX1340 /3340,4340	EE-SX1350 /3350,4350	EE-SX1235A-P2 /3239-P2, 4235A-P2	EE-SX460-P1	EE-SX3162 /4162-P1(-Z),P2	EE-SX3163 /4163-P1,P2	EE-SX3164 /4164-P1,P2
Sensing Type (Termination)	Transmissive (SMD)					Transmissive (Connectors)				
Appearance										
Mounting Type	Surface Mount	Surface Mount	Surface Mount	Surface Mount	Surface Mount	Snap-In	Snap-In	Screw-mounting	Screw-mounting	Screw-mounting
Sensing Distance	2 mm	2 mm	3 mm	4 mm	5 mm	5 mm	5 mm	5 mm	5 mm	5 mm
Output Configuration *2	PTTr/P-IC	PTTr	PTTr	PTTr/P-IC	PTTr/P-IC	PTTr/P-IC	P-IC	P-IC	P-IC	P-IC
Aperture Size	0.3 mm	0.3 mm	0.3 mm	0.5 mm	0.5 mm	0.5 mm	0.5 mm	0.5 mm	0.5 mm	0.5 mm
Dimensions	5.1x4x4	5.1x4x4	6x4x5	8x4x5.5	9x4x9	27x8x15.9	30x11x23.6	13x16x14	13.6x13.3x14.7	22.6x8.3x14
Features	Ultra-compact	Output 2ch, Ultra-compact	Ultra-compact	Compact	General purpose	High-resolution model	High-resolution model Easy to mount	Connector with lock manufactured	Connector with lock manufactured	Connector with lock manufactured

Model *1	EE-SX1046	EE-SX1106	EE-SX198 /398,498	EE-SX1071 /301,401	EE-SX1057	EE-SX1128	EE-SX1081 /3081,4081	EE-SX1041	EE-SX1042	EE-SX1035
Sensing Type (Termination)	Transmissive (Terminal)									
Appearance										
Mounting Type	Through-hole	Through-hole	Through-hole	Through-hole	Through-hole	Through-hole	Through-hole	Through-hole	Through-hole	Through-hole
Sensing Distance	3 mm	3 mm	3 mm	3.4 mm	3.6 mm	4.2 mm	5 mm	5 mm	5 mm	5.2 mm
Output Configuration *2	PTTr	PTTr	PTTr/P-IC	PTTr/P-IC	PTTr	PTTr	PTTr/P-IC	PTTr	PTTr	PTTr
Aperture Size	0.5 mm	0.4 mm	0.5 mm	0.5 mm	2 mm	0.5 mm	0.5 mm	0.5 mm	0.5 mm	1 mm
Dimensions	10x6.5x5	6.4x4.2x5.4	12.2x5x10	13.6x6.2x10.4 /15.4x6.2x10.4	13x6.35x11.5	13.5x5.2x9.3	13.7x5x10	14x6x10	14x5x14.5	12.6x6.3x6.9
Features	Horizontal aperture	Compact	General purpose without a positioning boss *3	General purpose	Dustproof	Horizontal aperture with a positioning boss	General purpose	with a positioning boss	High profile without a positioning boss *4	Compact with wide slot

Model *1	EE-SX1161-W11 /3161-W11, 4161-W11	EE-SX1088-W11 /3088-W11, 4088-W11	EE-SX1096-W11 /3096-W11, 4096-W11	EE-SX1160-W11 /3160-W11, 4160-W11	EE-SY1200	EE-SY171	EE-SY169, 169A, 169B	EE-SY113 /313,413	EE-SA105	EE-SA103
Sensing Type (Termination)	Transmissive (Prewired)				*Detachable connector			Reflective		Actuator
Appearance										
Mounting Type	Screw-mounting	Screw-mounting	Screw-mounting	Screw-mounting	Surface Mount	Through-hole	Through-hole	Through-hole	Through-hole	Through-hole
Sensing Distance	3.2 mm	3.4 mm	3.4 mm	9.5 mm	1 mm	3.5 mm	4 mm	4.4 mm	2.1 mm	3 mm
Output Configuration *2	PTTr/P-IC	PTTr/P-IC	PTTr/P-IC	PTTr/P-IC	PTTr	PTTr	PTTr	PTTr/P-IC	PTTr	PTTr
Aperture Size	0.5 mm	0.5 mm	0.5 mm	0.5 mm	---	---	---	---	---	0.5 mm
Dimensions	12.95x23.7x12.7	25x6x10	25x6x10	31.75x6x15.5	3.2x1.9x1.1	14x4.2x3	12.5x6x8	12x6.2x6	9.4x4.4x14.2	9x4x6
Features	Dustproof	General purpose	Horizontal aperture	Wide slot	Ultra-compact	Thin	Red LED, A: General purpose, B: Red LED, High power	Dustproof	Low operating force	Side attachment

*1 EE-SX3~...Dark On, EE-SX4~...Light On

*2 PTTr...Phototransistor, P-IC...Photo-IC

*3 With a positioning boss version...EE-SX199

*4 With a positioning boss version...EE-SX1115

Application examples

Rotation detection



Robots

Pass detection



Cash dispensers

Non-contact switch



Medication dispensers

Origin detection

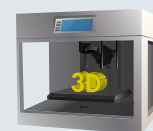

3D printers

Light Convergent Reflective Sensor B5W-LA

Ordering Information

Model	B5W-LA01
Detection range	MIN: 70mV (at 22.8 mm, Black paper) MAX: 30mV (at 70.0 mm, White paper)



Features

- Features 01 Applicability**
Detection of presence/absence of specular or black objects is possible
- Features 02 Robustness**
Minimal difference in sensing distance between different workpieces
- Features 03 High-performance**
Unique optical design technology

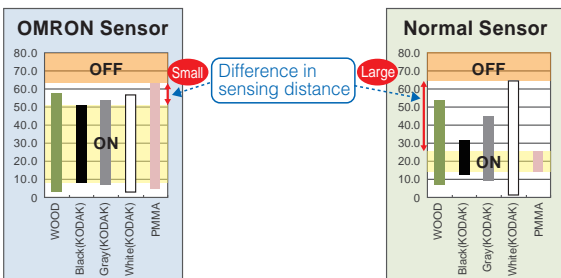

Application examples

Cliff detection

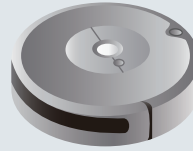

Robot vacuum cleaners

Non-contact switch

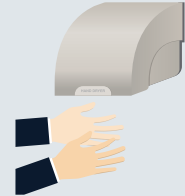

Sanitary equipment

Detection of object presence/absence in containers



Plastic container collectors/lockers

Transfer detection



Packing/Packaging machines

Air Quality Sensor B5W-LD

Ordering Information

Model	B5W-LD0101
Detection range	V(OUT1): Minimum detectable particle Approximately 0.5 μm V(OUT2): Minimum detectable particle Approximately 2.5 μm



Features

- Features 01 Highly Sensitive**
Detection of particles 0.5 μm in diameter is possible
- Features 02 Inflow performance**
Features a unique flow path structure that efficiently sucks in air
- Features 03 Small in size**
Miniaturized by unique optical design

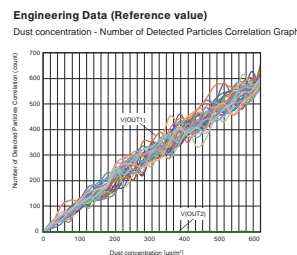

Application examples



Air cleaners



Ventilation systems



Air conditioners

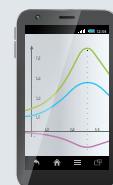





Environmental monitor

MEMS Flow Sensor D6F



Ordering Information

MEMS Flow Sensor





▶ Air
▶ Minute flow
▶ Analog

Applicable fluid		Air			
Items	Model	D6F-P0001A1	D6F-01A1-110/D6F-P0010A□/ D6F-P0010AM2	D6F-02A1-110	D6F-03A3-000
Shape					
Flow Range (L/min)		0 to 0.1 L/min	0 to 1 L/min	0 to 2 L/min	0 to 3 L/min

▶ Gas
▶ Minute to middle flow
▶ Analog





Applicable fluid		Natural gas (13A)	LP gas	Natural gas (13A)
Items	Model	D6F-01N2-000	D6F-02L2-000/D6F-02L7-000	D6F-05N2-000/D6F-05N7-000
Shape				
Flow Range (L/min)		0 to 0.1 L/min	0 to 2 L/min	0 to 5 L/min

▶ Air
▶ Minute to middle flow
▶ Analog
▶ Digital
🔒 Digital type only

Applicable fluid		Air				
Items	Model	D6F-10A5-000/D6F-10A6-000/ D6F-10A7-000/ D6F-10A7D-000	D6F-20A5-000/D6F-20A6-000/ D6F-20A7D-000	D6F-30A7-000/D6F-30AB71-000	D6F-50A5-000/D6F-50A6-000/ D6F-50A7D-000	D6F-70AB71-000/ D6F-70AB71D-000
Shape						
Flow Range (L/min)		0 to 10 L/min	0 to 20 L/min	0 to 30 L/min	0 to 50 L/min	0 to 70 L/min



MEMS 2-axis Flow Sensor/ MEMS Flow Sensor

▶ Air
▶ Velocity
▶ Analog
▶ Digital
🔒 Digital type only

Applicable fluid		Air				
Items	Model	D6F-D	D6F-W01A1	D6F-V03A1	D6F-W04A1	D6F-W10A1
Shape						
Velocity Range (m/s)		-1 to 1 m/s	0 to 1 m/s	0 to 3 m/s	0 to 4 m/s	0 to 10 m/s

MEMS Differential Pressure Sensor

▶ Air
▶ Differential pressure
▶ Digital
🔒 Digital type only

Applicable fluid		Air		
Items	Model	D6F-PH0505AD3	D6F-PH0025AD1	D6F-PH5050AD3
Shape				
Differential pressure range (Pa)		-50 to 50 Pa	0 to 250 Pa	-500 to 500 Pa

Features



High Accuracy

±3RD (25-100%F.S.) is realized by linear temperature correction using ASIC technology

Ambient temperature = 25degC (Model: D6F-20A7D-000-0)



High Sensitivity

Omron's unique MEMS technology allows detection of very low air velocities

Flow rate of 1L: Output corresponding to flow rate change below 1/1000 of full scale.



Compact

The product size is reduced by using the world-smallest class size MEMS sensor element

Dimension of D6F-V model: 24x8x14mm.

Product and Technical Overview

Measurement Principle of MEMS Flow Sensor D6F Series

Energy-efficient

During the absence of airflow, the temperature distribution around the heater is symmetrical. When there is airflow, the temperature of the upwind side cools down and the temperature of the downwind side warms up, disrupting the symmetry of the temperature distribution. By detecting this temperature difference appearing as a difference in the electromotive forces developed by the thermopiles, it allows the mass flow rate and mass flow velocity to be measured without the influence of temperature and pressure. Since the thermopile generates the thermo-electromotive force, the power consumption is much lower than when using the resistivity method.

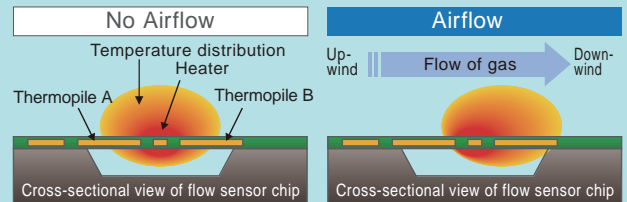

Highly Resistant to Dust - Built-in Dust Segregation System (cyclonic)

D6F-W/-V/-P

Patent No.4534526



The sensor can be placed anywhere thanks to its dust-resistant structure

Omron's unique design of 3D flow path provides a high level of reliability by separating dust particles to reduce its effect on the sensor chip. Additionally, Omron succeeded in reducing the sensor size, allowing it to be used in wider range of applications.

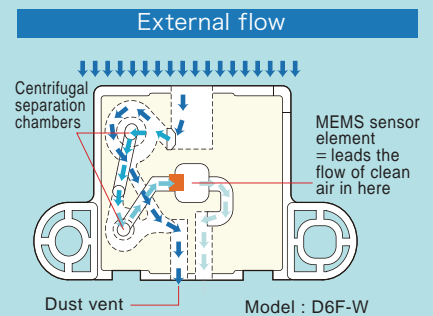

Application examples

Clogging detection

Flow rate Velocity Differential pressure



Projector



PC

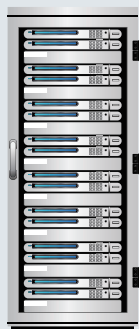

Server

Combustion control

Flow rate Differential pressure



Fuel cell

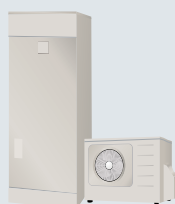

Water heater



Boiler

Air volume measurement

Velocity Differential pressure



Ducts

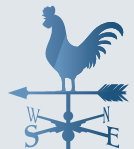



Airflow analysis (environment)



Air conditioner

MEMS Thermal Sensor D6T

Ordering Information

Model	D6T-1A-01	D6T-1A-02	D6T-8L-09	D6T-44L-06
Element	1 (1x1)		8 (1x8)	16 (4x4)
Appearance				
Object Temperature Detection Range	5 - 50°C	-40 - +80°C	5 - 50°C	5 - 50°C
View angle (X=X axis, Y=Y axis)	X = 58.0°, Y = 58.0°	X = 26.5°, Y = 26.5°	X = 54.5°, Y = 5.5°	X=44.2°, Y=45.7°

Features



High-precision

Achieving the highest level of SNR *1 in the world *2

*1 SNR: Signal-to-Noise Ratio. Compares the level of a signal to the level of background noise

*2 As of December 2017, according to OMRON research



Easy connection

Converts sensor signal to digital temperature output allowing easy use of microcontroller



Compact size

Space-saving design, well-suited for embedded applications

Application examples

Air conditioners, lighting systems, security systems, Industrial equipment, refrigerators

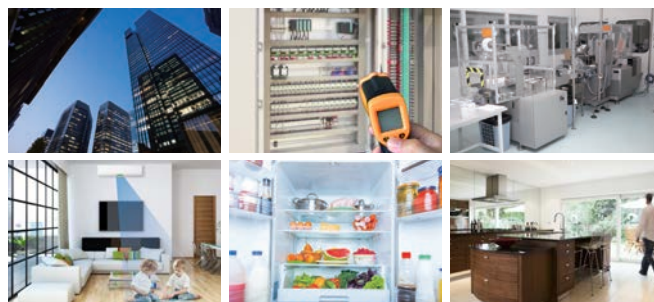

MEMS Barometric Pressure Sensor 2SMPB

Ordering Information

Model	2SMPB-02E
Pressure detection range	30 – 110 kPa

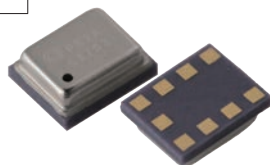

Features



High-precision absolute pressure measurement

Performing absolute pressure measurement with a precision of ± 0.5 hPa



Low noise output

Measuring height level differences of ± 5 cm



Stable pressure output

Detecting pressure fluctuations resulting from filter clogging



Application examples

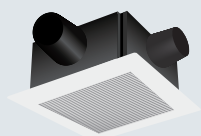

Ventilation systems



Navigation devices



Smartphones



Wearable devices



Filter clogging detection

Environment Sensor 2JCIE

Ordering Information

Model	2JCIE-BL01
Communication Interface	Bluetooth® low energy*
Sensors	Temperature, Humidity, Light, Absolute pressure, Noise, UVI



* The Bluetooth® word mark and logos are registered trademarks owned by Bluetooth SIG, Inc. and any use of such marks by OMRON Corporation is under license.

Features



Handy

Battery-operated with no external power supply required



Wireless

Output compatible with Bluetooth® low energy *



Multiple

Six types of sensing functions in a single package

Application examples

Application	Temperature	Humidity	Absolute pressure	Light	UVI	Noise
Home <ul style="list-style-type: none"> Watching over babies, elderly parents, and pets Checking when family members return Preparing for comfortable sleep 						
Office <ul style="list-style-type: none"> Maintaining a comfortable office environment 						
Outdoors <ul style="list-style-type: none"> Notifying weather changes and UV alerts Notifying heat stroke alerts 						
Factory <ul style="list-style-type: none"> Factory equipment diagnosis and work environment optimization 						

Seismic Sensor D7S

Ordering Information

Model	D7S-A0001
Acceleration sensing range	-2,000+2,000gal
Shutoff output	Output with a seismic intensity of 5-upper or above on the Japanese seismic scale of 7



Features



Ultra-compact

Ideal for embedded applications



Highly reliable

Prevention of false detection and non-detection



IoT-friendly

Secondary use of earthquake information is possible

Application examples

World's smallest-class seismic sensors can be used in a wide range of applications and is ideal for embedded applications.

Industry



Semiconductors/FPDs, machine tools, control panels, combustion furnaces, and printing machines

Life



Distribution boards, disaster prevention systems, and home appliances (heaters and gas stoves)

Society

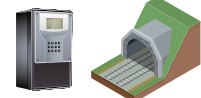

Electricity/gas meters, chemical plants, highways, bridges, tunnels, and railways

Human Vision Components (HVC) B5T

Ordering Information

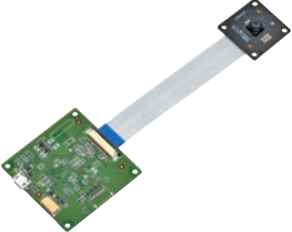
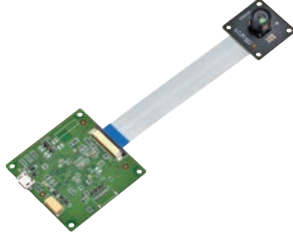
Item	Long-distance type B5T-007001-010	Wide-angle type B5T-007001-020
Appearance		
Horizontal detection range (angle of view)	Approximately 54 deg.	Approximately 94 deg.
Vertical detection range (angle of view)	Approximately 41 deg.	Approximately 76 deg.
Input resolution	1600x1200 pixel	
Output resolution	Selectable (no image output, 160 × 120 pixels, or 320 × 240 pixels)	
Dark location use	200 lx or above	
Supply voltage	DC 5 V ±0.5 V	
Consumption current	Below 0.4 A	
Power consumption	Below 2 W	
Operating temperature	0 to +50°C (no condensation or freezing)	
System	(1) UART 3.3 V (2) USB CDC-class device	

Features

Features
01

Choice of Wide-angle or Long-distance Detection Modules according to the sensing distance and range.

Features
02

Available for applications to analyze customer types from attribute information (age, gender, etc.) for marketing.

Features
03

Evaluation software and development tools can be downloaded free of charge from the following websites.

- Development tools [\[English\] https://www.components.omron.com/](https://www.components.omron.com/)
Click here to download [\[Japanese\] https://www.omron.co.jp/ecb/](https://www.omron.co.jp/ecb/)

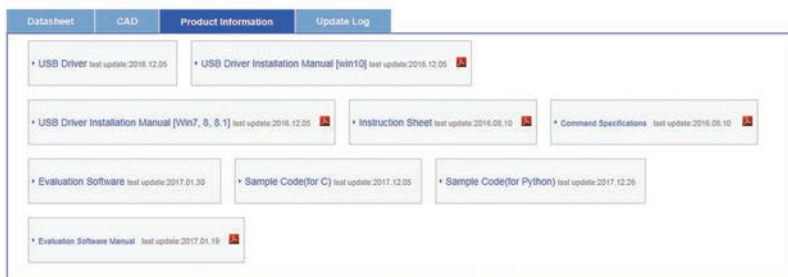

Development tool download page

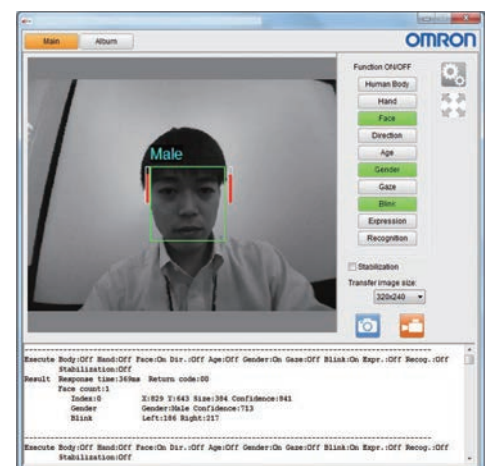

Evaluation software (actual layout may differ)

Product and Technical Overview

- Incorporating different human vision sensing technologies supported by face information on over one million people (with cumulative shipment results of one billion or more licenses *).



* Cumulative number of shipment licenses in the past 10 years as of April 2018, based on OMRON investigation.

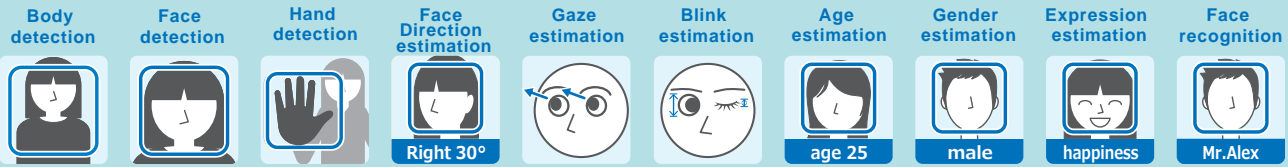

* The OKAO® name and logo are registered trademarks or trademarks of OMRON Corporation in Japan and other countries.

- Making use of the strengths of a compact and high-speed algorithm to modularize different human vision sensing technologies.

▶▶▶ Easy to install even to customers' equipment not normally provided with cameras.

* System construction after receiving output from the product is necessary.

Customer's equipment that did not previously have a camera



Application examples

Application Examples

Vending and Ticketing Machines, POS, Digital Signage

- Customer attributes (such as age, gender, and expression) and line-of-sight data (such as degree of interest in products) are analyzed for effective product marketing.
- Switch Displayed product recommendations and advertisements according to the user attributes.

Function examples:
Face detection, age estimation, gender estimation, and expression estimation



Amusement Machines, Robots

- The operator is identified and actions are changed accordingly.
- The Module can be used as robot eyes to identify and communicate with users.

Function examples:
Face detection, body detection, face recognition, and expression estimation

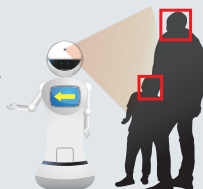

Application-specific Modules

Wide-angle Detection Module B5T-007001-020

Ideal for detecting targets at a relatively short distance over a wide angle.



Long-distance Detection Module B5T-007001-010

Ideal for detecting targets at a relatively long distance.

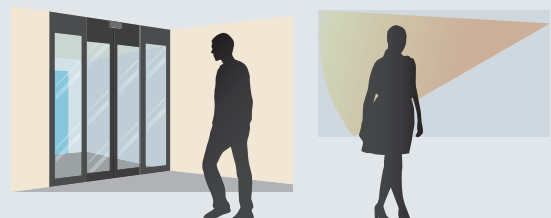

Please check each region's Terms & Conditions by region website.

OMRON Corporation

Electronic and Mechanical Components Company

Regional Contact

Americas

<https://www.components.omron.com/>

Asia-Pacific

<https://ecb.omron.com.sg/>

Korea

<https://www.omron-ecb.co.kr/>

Europe

<http://components.omron.eu/>

China

<https://www.ecb.omron.com.cn/>

Japan

<https://www.omron.co.jp/ecb/>