

AN10753

ESD protection for USB 2.0 interfaces

Rev. 3 — 5 February 2013

Application note

Document information

Info	Content
Keywords	ESD, USB, PESD5V0X1BL, PESD12VS1UL, PRTR5V0U2F, PRTR5V0U2K
Abstract	This application note describes how to protect USB 2.0 ports with NXP general-application discretes parts, i.e. low-capacitance ElectroStatic Discharge (ESD) protection diodes PESD5V0X1BL, PRTR5V0U2F and PRTR5V0U2K.



Revision history

Rev	Date	Description
3	20130205	Section 6 "Appendix" added.
2	20101101	Measurement results for PRTR5V0U2F and PRTR5V0U2K added. Table 2 "Device ESD failure threshold classification according to MIL-STD 883" added.
1	20090115	Initial version

Contact information

For more information, please visit: <http://www.nxp.com>

For sales office addresses, please send an email to: salesaddresses@nxp.com

1. Introduction

An Integrated Circuit (IC) connected to external ports can be damaged by ElectroStatic Discharge (ESD) from the operating environment.

The result of ever-shrinking IC process technology is the decrease of ESD robustness because of the smaller geometry of the silicon die.

Traditional methods to prevent ICs from ESD damage are the implementation of additional devices such as:

- Zener diodes
- Varistors
- Transient Voltage Suppressor (TVS) diodes
- Bipolar clamp diodes

However, at much higher data rates, the parasitic characteristics can distort or deteriorate signal integrity. This application note examines the general parameters the hardware designer should look at to increase the ESD robustness of the application, e.g. USB interfaces.

2. ElectroStatic Discharge (ESD) basics

ESD events are one of the most challenging issues in the semiconductor industry these days due to ever-shrinking IC structures of semiconductor devices.



Fig 1. Typical attention sign

The smaller the geometry of the silicon die, the more ESD sensitive are the ICs, and the more IC area is required for the ESD protection of the device (see [Figure 2](#)).

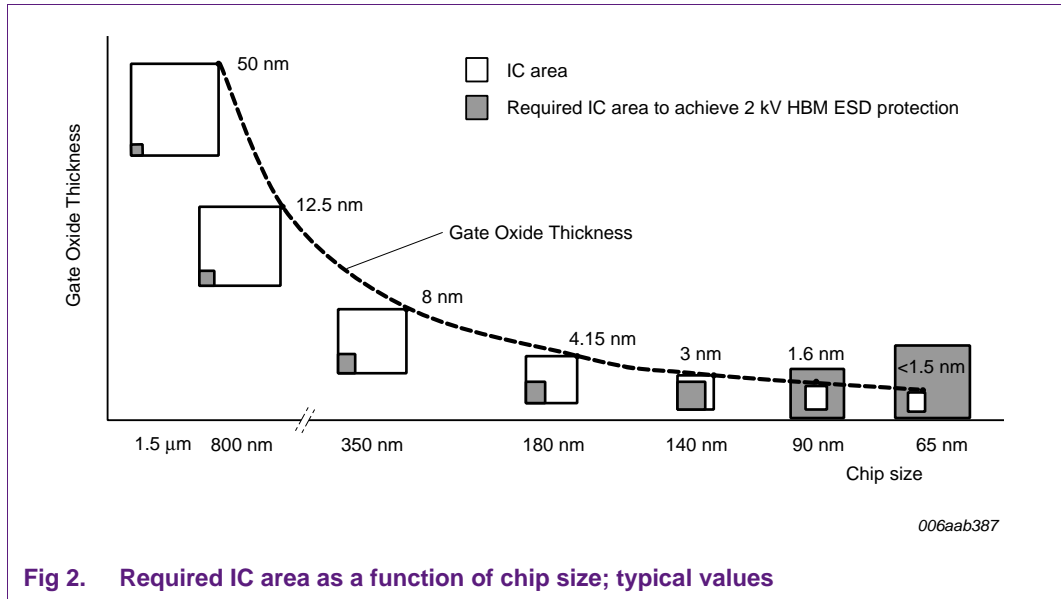

Fig 2. Required IC area as a function of chip size; typical values

An ESD event is the transfer of energy between two bodies of different electrostatic potential.

ElectroStatic Discharge can happen by contact, or via an ionized ambient discharge.

There are several models known:

- Human Body Model (HBM) - A human body is discharged to an electronic component.
- Machine Model (MM) - A machine or tool is discharged to an electronic component.
- Charged Device Model (CDM) - An electronic component is discharged to the ambient.
- System Level (IEC) - A human body is discharged to a powered system.

This application note covers the difference between the Human Body Model and the System Level Model which are both Human Body Models, but the System Level Model is relevant for a complete solution, e.g. a portable multimedia device.

2.1 Human Body Model (HBM) - Standards IEC/EN 61340-3-1 or MIL-STD 883

This standard covers the manual handling of none-powered electronic components. The handling can be picking up a device for testing or mounting the device on a Printed-Circuit Board (PCB)!

A capacitor of 100 pF is charged and then discharged via a 1.5 kΩ resistor to the Device Under Test (DUT).

The waveform of IEC 61340-3-1 is shown in [Figure 3](#), the rise time is defined up to 10 ns.

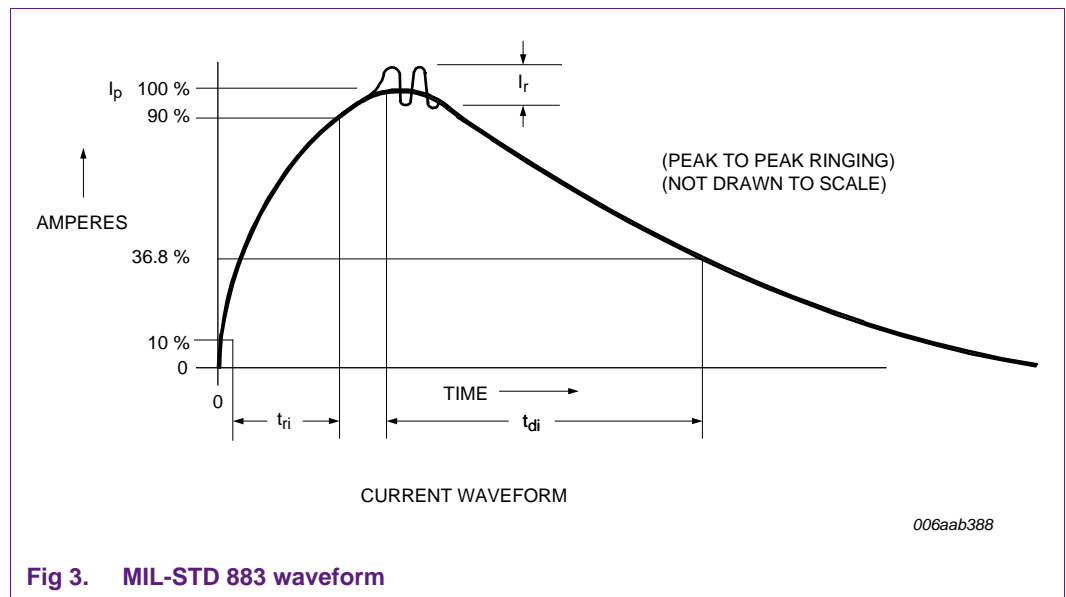

Fig 3. MIL-STD 883 waveform

Table 1. Waveform parameters according to MIL-STD 883

Step	Test voltage (kV)	Peak current (A)
1	0.5	0.33
2	1	0.67
3	2	1.33
4	4	2.67

Table 2. Device ESD failure threshold classification according to MIL-STD 883

Class	Threshold voltage (V)
0	< 250
1A	250 to 499
1B	500 to 999
1C	1000 to 1999
2	2000 to 3999
3A	4000 to 7999
3B	≥ 8000

2.2 System Level (IEC) - Standard IEC 61000-4-2

This standard covers the manual handling of a powered electronic system, e.g. touching an interface connector.

A capacitor of 150 pF is charged and then discharged via a 330 Ω resistor to the DUT.

The waveform of IEC 61000-4-2 is shown in [Figure 4](#), the rise time is defined between 0.7 ns and 1 ns.

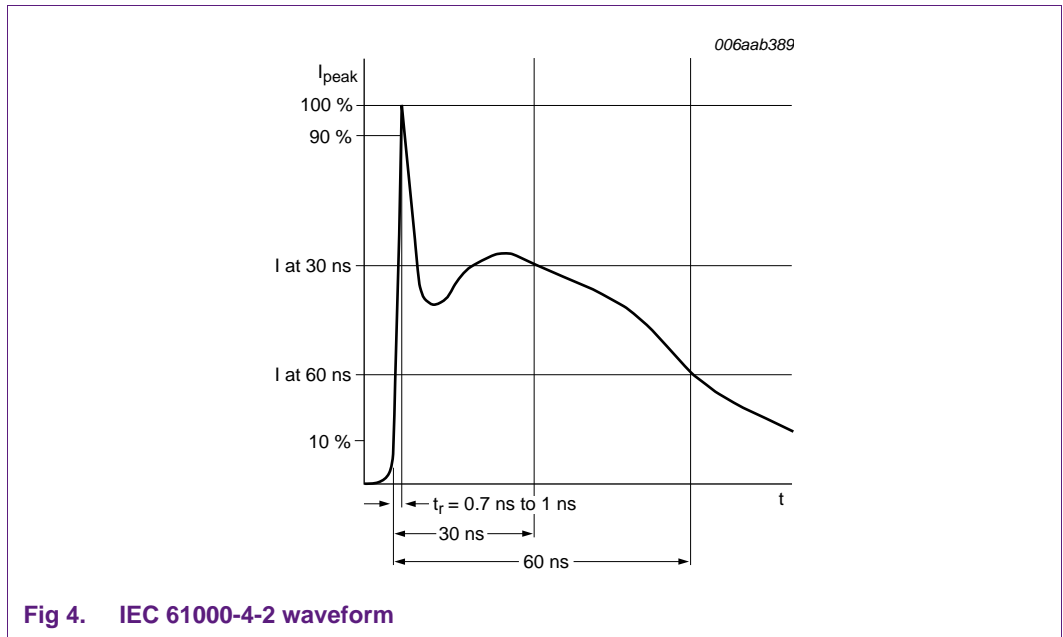

Fig 4. IEC 61000-4-2 waveform

There are different levels for test proposals mentioned.

For contact or air discharge test, they differ in the voltage values (see [Table 3](#)).

Table 3. Waveform parameters according to IEC 61000-4-2

Level	Test voltage (kV)		Current (A)		
	Contact	Air	Peak current	After 30 ns	After 60 ns
1	2	2	7.5	4	2
2	4	4	15	8	4
3	6	8	22.5	12	6
4	8	15	30	16	8

2.3 Standard comparison

Both models differentiate concerning the test voltages.

One can see that a 2 kV discharge voltage refers to different discharge currents.

Therefore, NXP recommends external ESD protection to be compliant with the IEC 61000-4-2 standard.

3. USB interface protection

The USB 2.0 standard covers several data transmission rates. It is also compliant to the former specification USB 1.1.

Following data transmission rates are covered:

- 1.5 MBit/s (low speed)
- 12.0 MBit/s (full speed)
- 480 MBit/s (hi-speed)

For the hi-speed mode, the maximum allowed capacitance according to the USB 2.0 specification is 10 pF overall.

These 10 pF are shared by a maximum of 5 pF for the transceiver itself, and the other 5 pF for the connector, PCB traces, and additional components.

[Figure 5](#) shows the maximum allowable line capacitance at different data speeds.

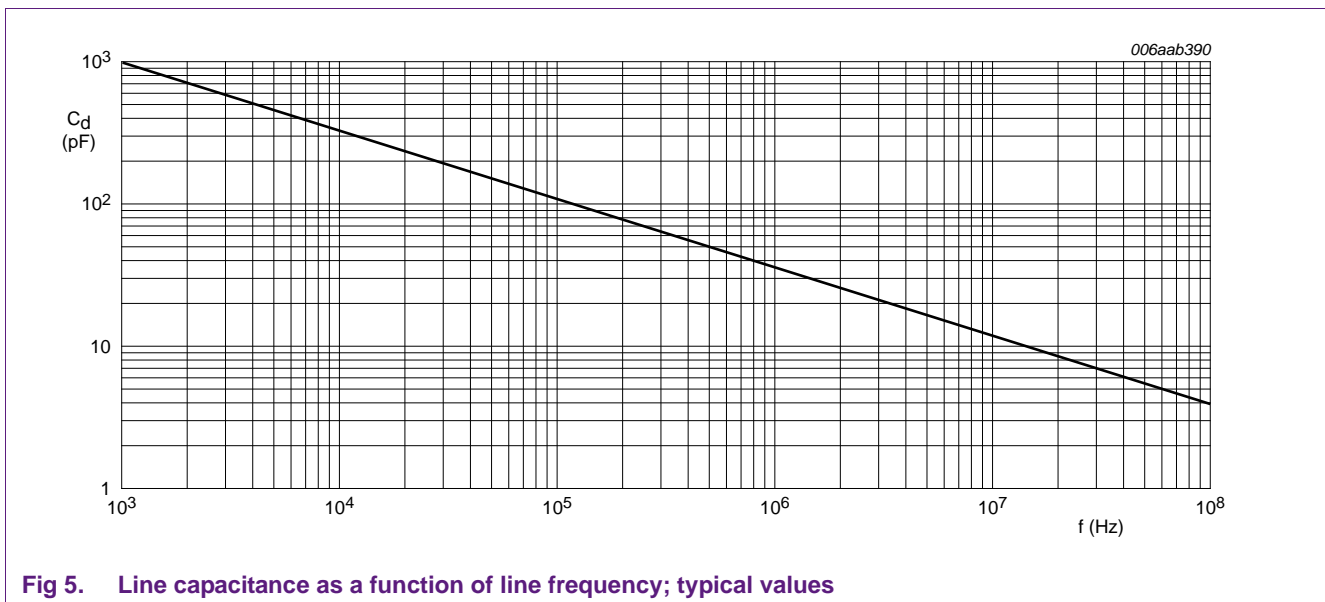

Fig 5. Line capacitance as a function of line frequency; typical values

To expose any issue in USB data lines, the measurement method “eye pattern”, also known as “eye diagram”, is used.

It represents a digital signal that provides minimum and maximum voltage levels and signal jitter.

One can also measure the signal rise time and the fall time, as well as overshoot and undershoot.

Line capacitance and bandwidth effects of the USB data transmission can be evaluated!

USB 2.0 signal mask specifications are provided by the USB Implementers Forum.

Figure 6 shows an “eye pattern” with the critical issues of a USB 2.0 data signal.

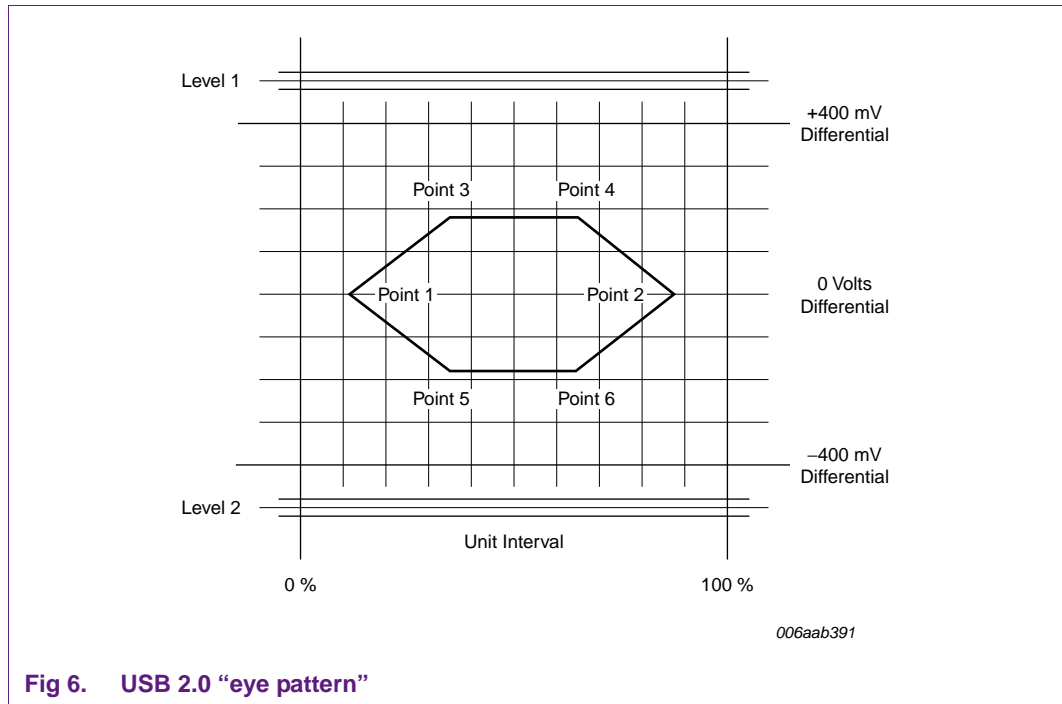

Fig 6. USB 2.0 “eye pattern”

3.1 Component differences

The NXP product portfolio offers two different approaches:

One component for each single line to be protected:

- Single-line protection for D+ and D– bidirectional configuration (PESD5V0X1BL).
- Single-line protection for V_{BUS} unidirectional configuration (PESD12VS1UL).

One package for complete USB interface protection:

- Dual line protection in rail-to-rail configuration, i. e. D+, D– and V_{BUS} (PRTR5V0U2x).

4. Measurement methods

4.1 USB 2.0 protection with PESD5V0X1BL

To evaluate the PESD5V0X1BL behavior in USB 2.0 applications, a reference board (see Figure 7) was designed.

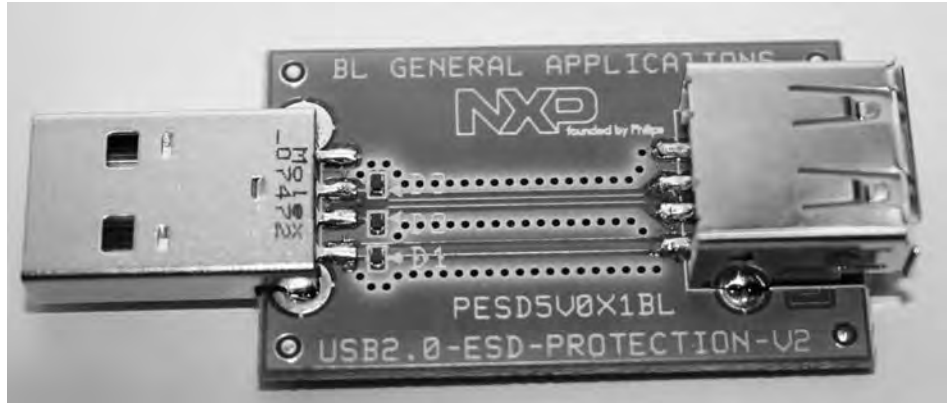

006aab392

Fig 7. USB 2.0-ESD-Protection-V2-board

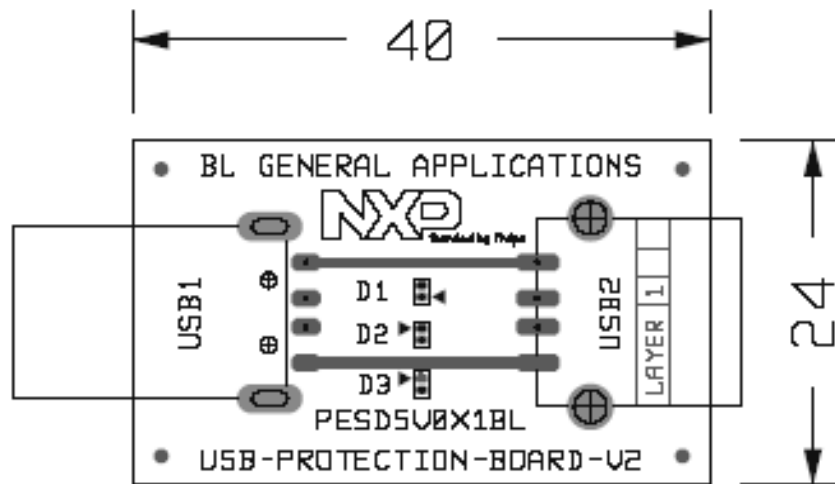

006aab393

Fig 8. USB 2.0-ESD-Protection-V2-assembly diagram

4.1.1 Reference measurements

To evaluate the influence of different ESD protection components, the measurements were done in several steps.

A board without a device was evaluated as reference.

Comparing all “eye patterns” demonstrates the degradation caused by the ESD protection devices.

The first test was done without any protection diode (see [Figure 11](#)), the result pattern is shown in [Figure 13](#).

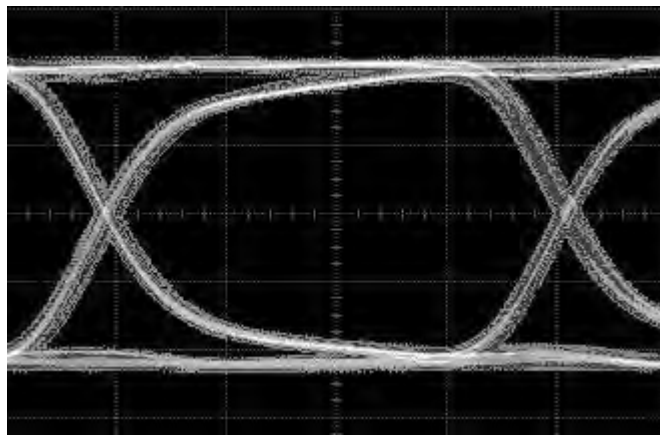

006aab396

Fig 11. USB 2.0 “eye pattern” without DUT

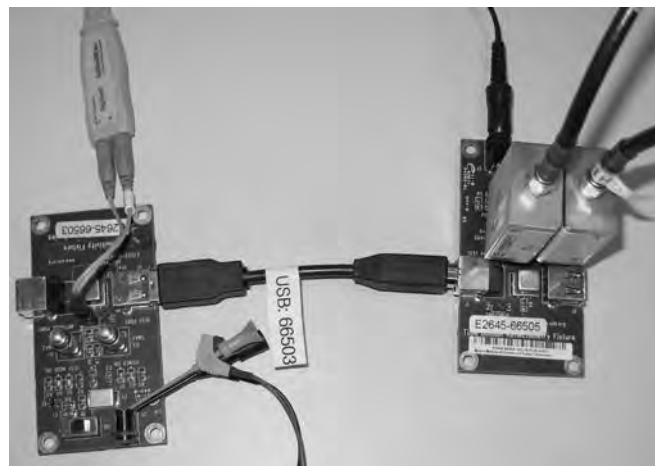

006aab397

Fig 12. Test setup for USB 2.0 “eye pattern” without DUT

4.1.2 DUT measurements

DUT measurements done on three different PCBs using two different PESD5V0X1BL diodes each are shown below.

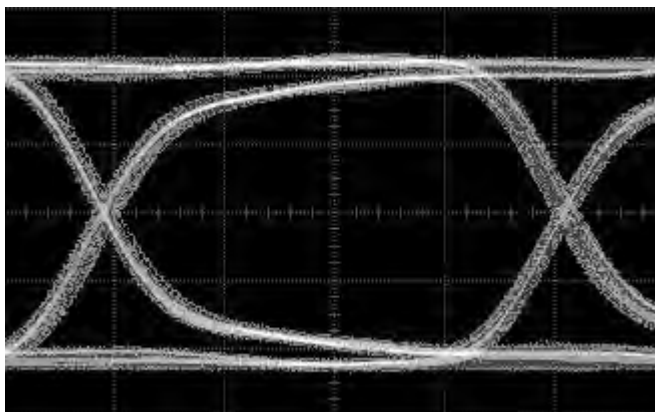

006aab398

Fig 13. USB 2.0 “eye pattern” with a 0.9 pF PESD5V0X1BL ESD protection diode; PCB1

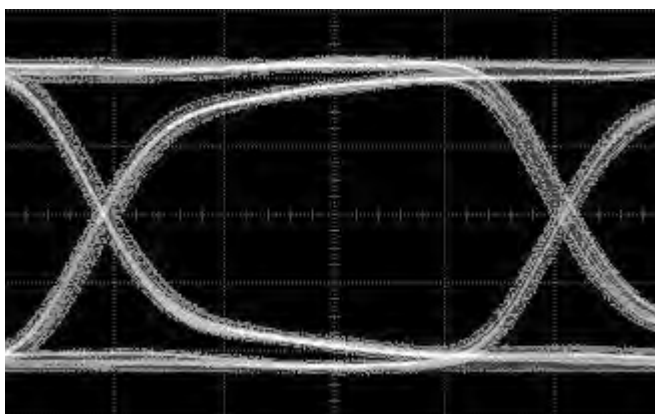

006aab399

Fig 14. USB 2.0 “eye pattern” with a 0.9 pF PESD5V0X1BL ESD protection diode; PCB2

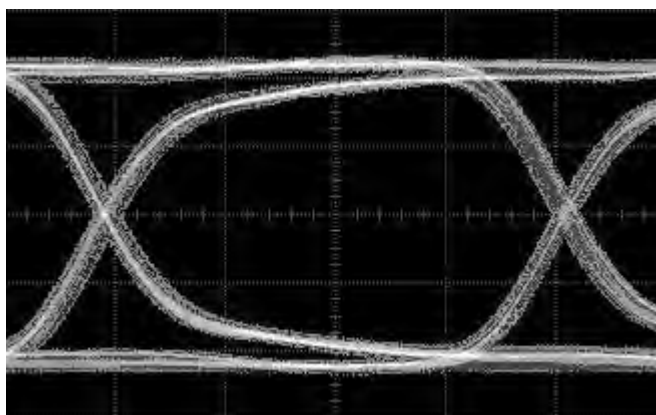

006aab400

Fig 15. USB 2.0 “eye pattern” with a 0.9 pF PESD5V0X1BL ESD protection diode; PCB3

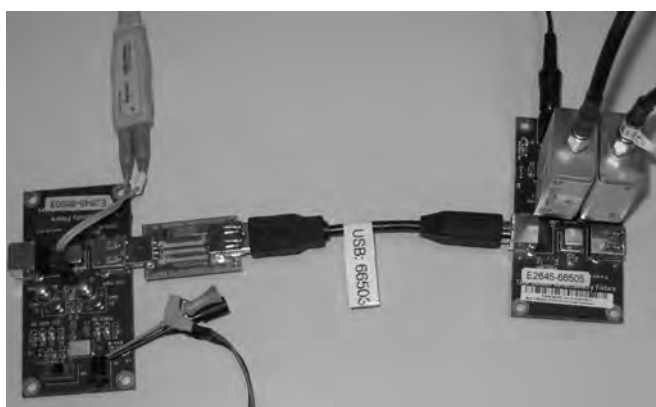

006aab401

Fig 16. Test setup for USB 2.0 “eye pattern” with a 0.9 pF PESD5V0X1BL ESD protection diode

4.2 USB 2.0 protection with PRTR5V0U2F/K

In order to evaluate the PRTR5V0U2F/K behaviors in USB 2.0 applications, two reference boards were designed (see [Figure 17](#) and [Figure 18](#)).



006aac463

Fig 17. USB 2.0 ESD-Protection-V3-board

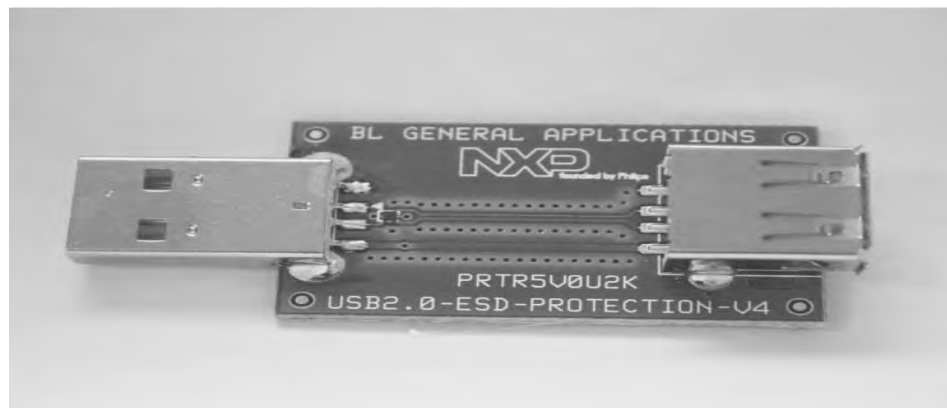

006aac464

Fig 18. USB 2.0 ESD-Protection-V4-board

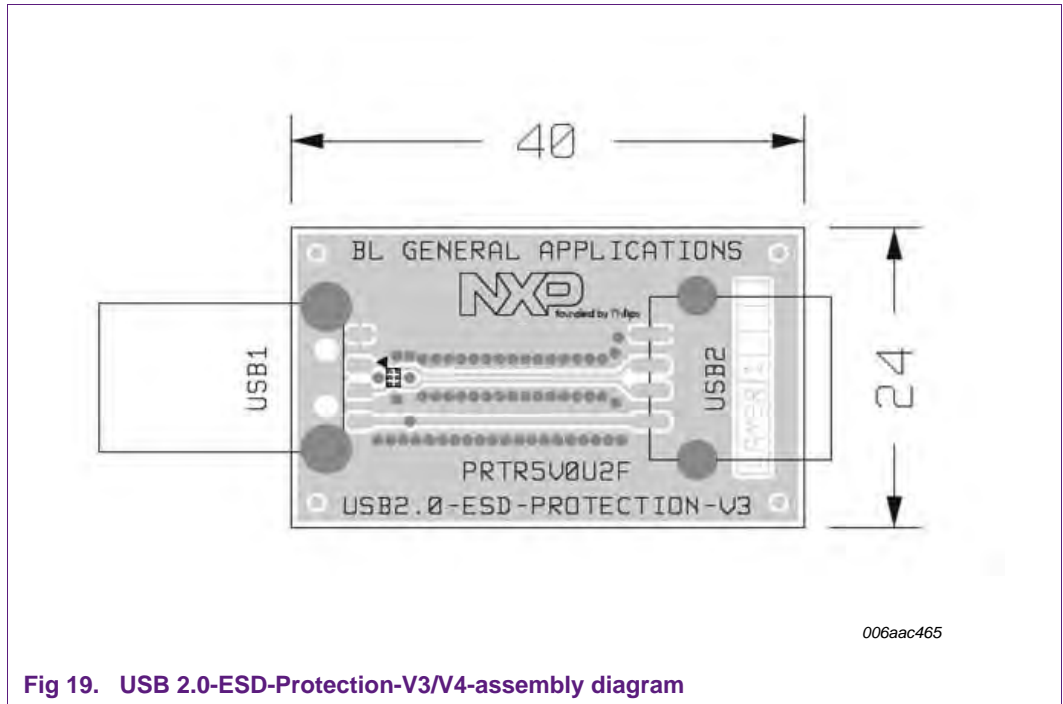

Fig 19. USB 2.0-ESD-Protection-V3/V4-assembly diagram

The PCB layer structure for the USB 2.0-ESD-Protection-V3/V4-assembly diagram as shown in [Figure 19](#) is similar to the USB 2.0-ESD-Protection-V2-board (see [Figure 9](#)).

[Figure 20](#) provides the schematic of both, V3 and V4 reference boards, with only slight differences with respect to the packages. PRTR5V0U2F is housed in an SOT886 package of dimensions 1.45 × 1 × 0.5 mm, and PRTR5V0U2K is housed in an SOT891 package of dimensions 1 × 1 × 0.5 mm.

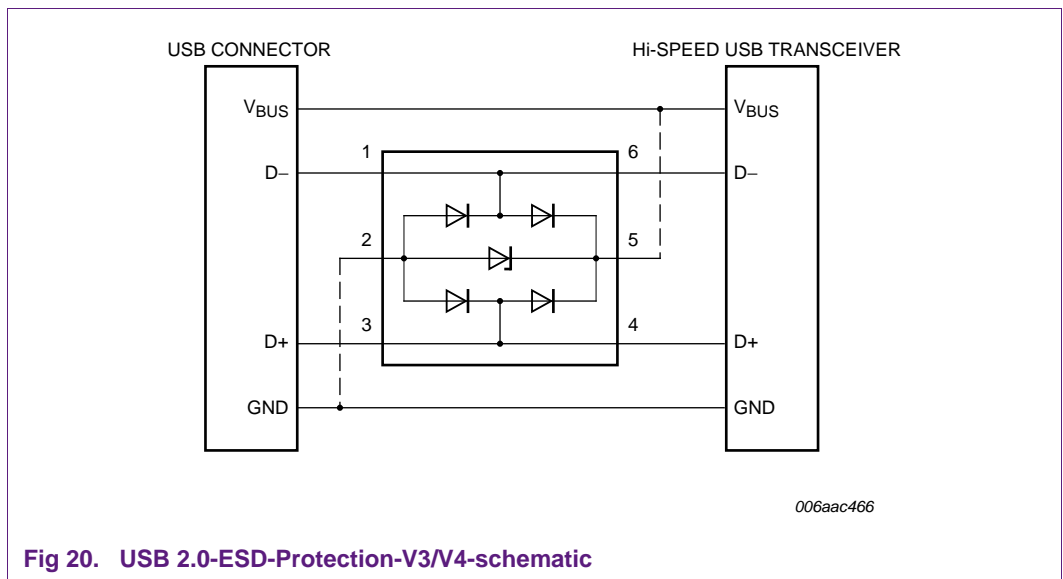

Fig 20. USB 2.0-ESD-Protection-V3/V4-schematic

4.2.1 Reference measurements

To evaluate the influence of different ESD protection components, the measurements were done in several steps.

A board without a device was evaluated as reference.

Comparing all “eye patterns” demonstrates the degradation caused by the ESD protection devices.

The first test was done without any protection diode (see [Figure 21](#)) using a similar test setup to [Figure 12](#).

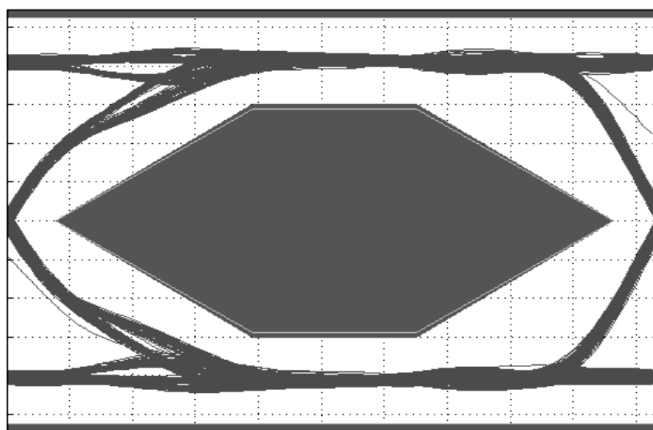

006aac467

Fig 21. USB 2.0 “eye pattern” without DUT

4.2.2 DUT measurements

The DUT measurements were done on three different PCBs using PRTR5V0U2F and PRTR5V0U2K on a similar test setup to [Figure 16](#).

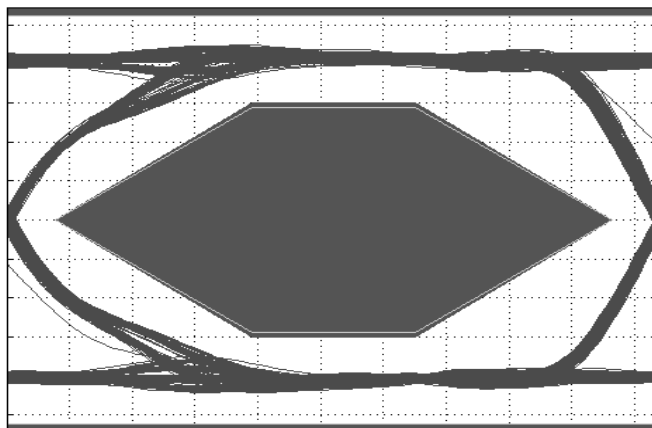

006aac468

Fig 22. USB 2.0 “eye pattern” with PRTR5V0U2F protection diode; PCB1

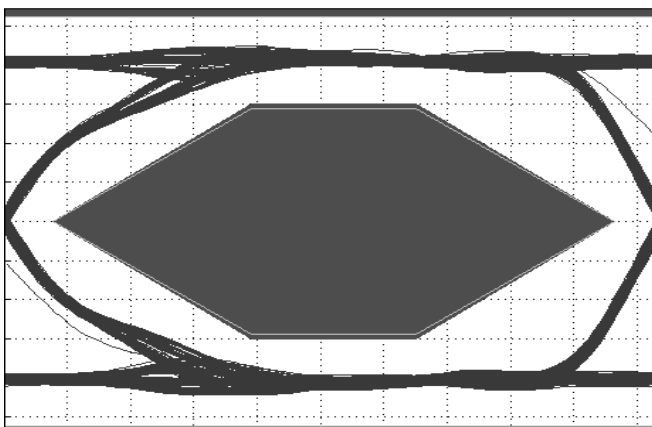

006aac469

Fig 23. USB 2.0 “eye pattern” with PRTR5V0U2F protection diode; PCB2

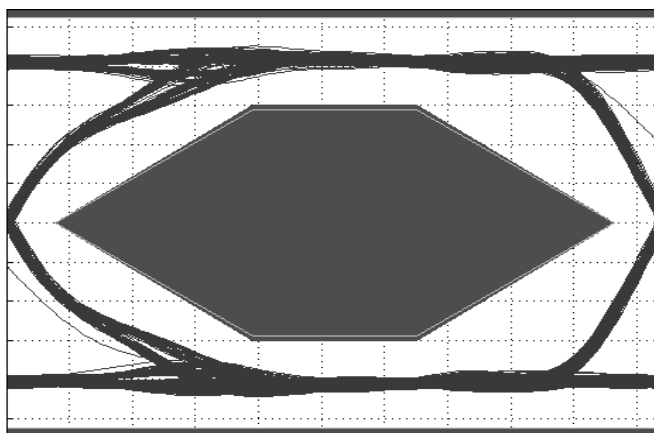

006aac470

Fig 24. USB 2.0 “eye pattern” with PRTR5V0U2F protection diode; PCB3

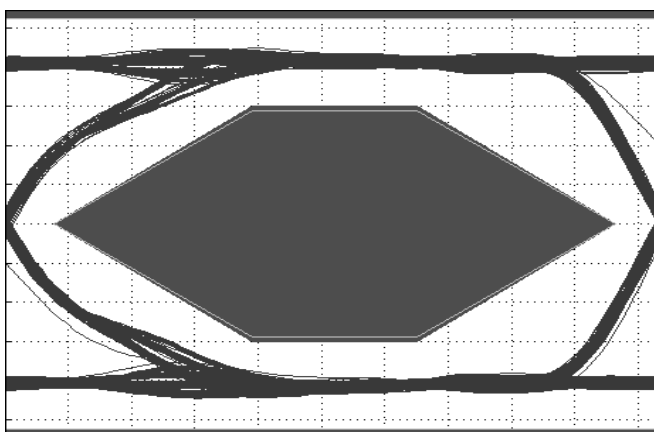

006aac471

Fig 25. USB 2.0 “eye pattern” with PRTR5V0U2K protection diode; PCB1

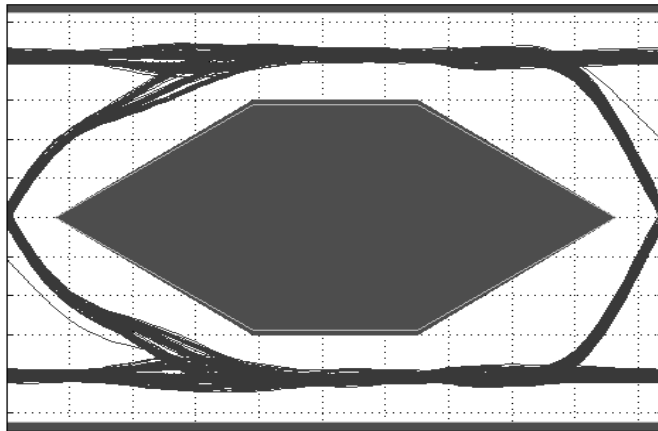

006aac472

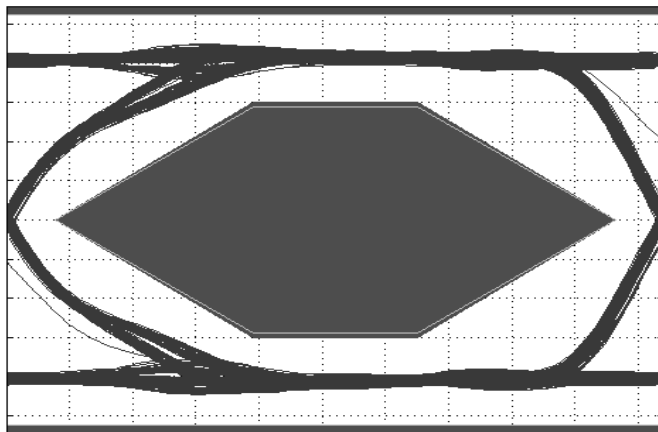
Fig 26. USB 2.0 “eye pattern” with PRTR5V0U2K protection diode; PCB2

006aac473

Fig 27. USB 2.0 “eye pattern” with PRTR5V0U2K protection diode; PCB3

5. Summary

The NXP low-capacitance ESD protection devices offer best results for USB 2.0 hi-speed applications.

The “eye pattern” evaluations show that NXP’s low-capacitance ESD protection devices have an extremely low impact on the USB 2.0 data signals.

This option gives the hardware designer some space for additional capacitance on the USB 2.0 signal lines!

6. Appendix

6.1 USB 2.0 ESD protection portfolio

Table 4. USB 2.0 ESD protection portfolio

Type number	C _{line} [1]	V _{BUS(max)}	ESD rating	Package	AEC-Q101
PRTR5V0U2X	1.0 pF	5.0 V	8 kV	SOT143B	YES
PRTR5V0U2AX	1.8 pF	5.0 V	8 kV	SOT143B	YES
PRTR5V0U4D	1.0 pF	5.0 V	8 kV	SOT457	YES
PRTR5V0U2F	1.0 pF	5.0 V	8 kV	DFN1410-6	NO
PRTR5V0U2K	1.0 pF	5.0 V	8 kV	DFN1010-6	NO
PUSBM5V5X4-TL	1.0 pF	5.5 V	8 kV	DFN1616-6	NO
PUSBM12VX4-TL	1.0 pF	12 V	8 kV	DFN1616-6	NO
PUSBM15VX4-TL	1.0 pF	15 V	8 kV	DFN1616-6	NO
PUSBM30VX4-TL	1.0 pF	30 V	8 kV	DFN1616-6	NO
IP4369CX4	0.8 pF	only D- lines	8 kV	WLCSP4	NO

[1] Data lines (D+/D-)

6.2 USB 3.0 ESD protection portfolio

Table 5. USB 3.0 ESD protection portfolio

Type number	C _{line}	V _{BUS(max)}	ESD rating	Package	AEC-Q101
IP4294CZ10-TBR	0.50 pF	only D- lines	10 kV	DFN2510A-10	NO
IP4292CZ10-TBR	0.55 pF	only D- lines	8 kV	DFN2510A-10	NO

7. Legal information

7.1 Definitions

Draft — The document is a draft version only. The content is still under internal review and subject to formal approval, which may result in modifications or additions. NXP Semiconductors does not give any representations or warranties as to the accuracy or completeness of information included herein and shall have no liability for the consequences of use of such information.

7.2 Disclaimers

Limited warranty and liability — Information in this document is believed to be accurate and reliable. However, NXP Semiconductors does not give any representations or warranties, expressed or implied, as to the accuracy or completeness of such information and shall have no liability for the consequences of use of such information. NXP Semiconductors takes no responsibility for the content in this document if provided by an information source outside of NXP Semiconductors.

In no event shall NXP Semiconductors be liable for any indirect, incidental, punitive, special or consequential damages (including - without limitation - lost profits, lost savings, business interruption, costs related to the removal or replacement of any products or rework charges) whether or not such damages are based on tort (including negligence), warranty, breach of contract or any other legal theory.

Notwithstanding any damages that customer might incur for any reason whatsoever, NXP Semiconductors' aggregate and cumulative liability towards customer for the products described herein shall be limited in accordance with the *Terms and conditions of commercial sale* of NXP Semiconductors.

Right to make changes — NXP Semiconductors reserves the right to make changes to information published in this document, including without limitation specifications and product descriptions, at any time and without notice. This document supersedes and replaces all information supplied prior to the publication hereof.

Suitability for use — NXP Semiconductors products are not designed, authorized or warranted to be suitable for use in life support, life-critical or safety-critical systems or equipment, nor in applications where failure or malfunction of an NXP Semiconductors product can reasonably be expected to result in personal injury, death or severe property or environmental damage. NXP Semiconductors and its suppliers accept no liability for inclusion and/or use of NXP Semiconductors products in such equipment or applications and therefore such inclusion and/or use is at the customer's own risk.

Applications — Applications that are described herein for any of these products are for illustrative purposes only. NXP Semiconductors makes no representation or warranty that such applications will be suitable for the specified use without further testing or modification.

Customers are responsible for the design and operation of their applications and products using NXP Semiconductors products, and NXP Semiconductors accepts no liability for any assistance with applications or customer product design. It is customer's sole responsibility to determine whether the NXP Semiconductors product is suitable and fit for the customer's applications and products planned, as well as for the planned application and use of customer's third party customer(s). Customers should provide appropriate design and operating safeguards to minimize the risks associated with their applications and products.

NXP Semiconductors does not accept any liability related to any default, damage, costs or problem which is based on any weakness or default in the customer's applications or products, or the application or use by customer's third party customer(s). Customer is responsible for doing all necessary testing for the customer's applications and products using NXP Semiconductors products in order to avoid a default of the applications and the products or of the application or use by customer's third party customer(s). NXP does not accept any liability in this respect.

Export control — This document as well as the item(s) described herein may be subject to export control regulations. Export might require a prior authorization from competent authorities.

Evaluation products — This product is provided on an "as is" and "with all faults" basis for evaluation purposes only. NXP Semiconductors, its affiliates and their suppliers expressly disclaim all warranties, whether express, implied or statutory, including but not limited to the implied warranties of non-infringement, merchantability and fitness for a particular purpose. The entire risk as to the quality, or arising out of the use or performance, of this product remains with customer.

In no event shall NXP Semiconductors, its affiliates or their suppliers be liable to customer for any special, indirect, consequential, punitive or incidental damages (including without limitation damages for loss of business, business interruption, loss of use, loss of data or information, and the like) arising out of the use of or inability to use the product, whether or not based on tort (including negligence), strict liability, breach of contract, breach of warranty or any other theory, even if advised of the possibility of such damages.

Notwithstanding any damages that customer might incur for any reason whatsoever (including without limitation, all damages referenced above and all direct or general damages), the entire liability of NXP Semiconductors, its affiliates and their suppliers and customer's exclusive remedy for all of the foregoing shall be limited to actual damages incurred by customer based on reasonable reliance up to the greater of the amount actually paid by customer for the product or five dollars (US\$5.00). The foregoing limitations, exclusions and disclaimers shall apply to the maximum extent permitted by applicable law, even if any remedy fails of its essential purpose.

7.3 Trademarks

Notice: All referenced brands, product names, service names and trademarks are the property of their respective owners.

8. Contents

1	Introduction	3
2	ElectroStatic Discharge (ESD) basics	3
2.1	Human Body Model (HBM) - Standards IEC/EN 61340-3-1 or MIL-STD 883.	5
2.2	System Level (IEC) - Standard IEC 61000-4-2.	6
2.3	Standard comparison	7
3	USB interface protection	7
3.1	Component differences.	8
4	Measurement methods	9
4.1	USB 2.0 protection with PESD5V0X1BL	9
4.1.1	Reference measurements	11
4.1.2	DUT measurements	12
4.2	USB 2.0 protection with PRTR5V0U2F/K.	14
4.2.1	Reference measurements	16
4.2.2	DUT measurements	17
5	Summary	19
6	Appendix	20
6.1	USB 2.0 ESD protection portfolio	20
6.2	USB 3.0 ESD protection portfolio	20
7	Legal information	21
7.1	Definitions.	21
7.2	Disclaimers	21
7.3	Trademarks	21
8	Contents	22

Please be aware that important notices concerning this document and the product(s) described herein, have been included in section 'Legal information'.

© NXP B.V. 2013.

All rights reserved.

For more information, please visit: <http://www.nxp.com>

For sales office addresses, please send an email to: salesaddresses@nxp.com

Date of release: 5 February 2013

Document identifier: AN10753