



Power Train

 Automotive



Expertise Applied | Answers Delivered

Users must independently evaluate the suitability of and test each product selected for their own specific applications. It is the User's sole responsibility to determine fitness for a particular system or use based on their own performance criteria, conditions, specific application, compatibility with other components and environmental conditions. Users must independently provide appropriate design and operating safeguards to minimize any risks associated with their applications and products. Littelfuse products are not designed for, and may not be used in, all applications.

Read complete Disclaimer Notice at: www.littelfuse.com/disclaimer-electronics.

Advanced electronics are driving innovation in multiple automotive applications

A Infotainment and communication

- Smart infotainment
- Navigation
- Multipurpose camera
- Telematics box



B Network systems & body electronics

- CAN, LIN
- USB, Wireless
- Keyless entry
- Lighting control



C Advanced Driver Assistance System

- V2X Communication
- Radar
- eCall
- Sensor fusion



D Power train

- Battery management system
- On-board charger
- Traction motor inverter
- DC/DC converter



E Chassis and safety system

- Seatbelt safety
- Tire pressure monitoring
- Battery disconnect
- Fuel level detection

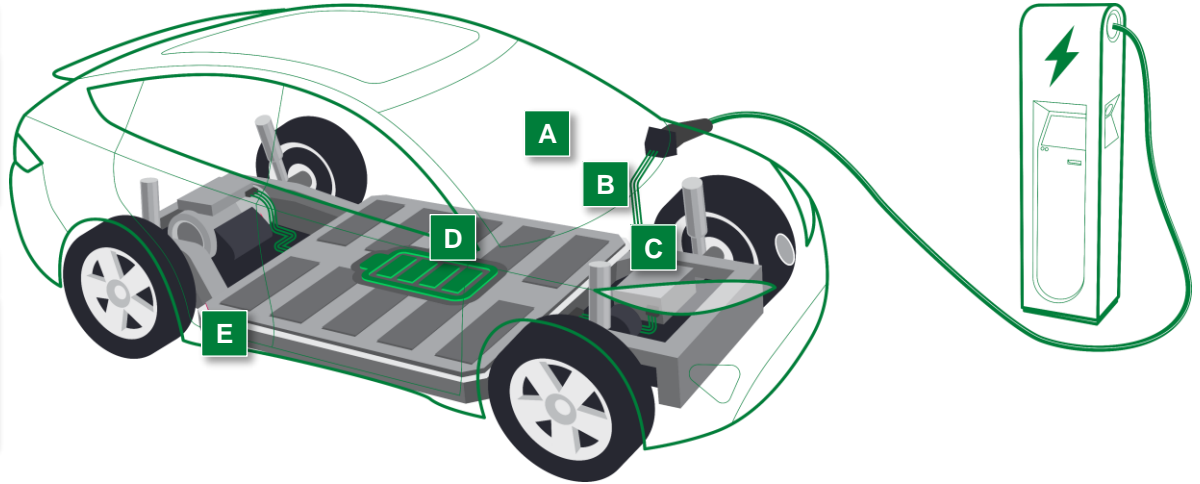

Increased need for circuit protection, power control, and sensing products to ensure safety and reliability

xEV market key takeaways

Market trends

Global sales of passenger cars were sluggish in 2019, but electric cars had another banner year. The global electric car fleet was 7.2 million (2019) versus 5.1 million (2018). Global EV sales will reach 25 million units by 2030. China will continue to dominate the EV market.

The infrastructure for electric vehicle charging continues to expand. There were 7.3 million chargers worldwide in 2019 (6.5 million were private). Convenience, cost-effectiveness, and a variety of support policies such as preferential rates, equipment purchase incentives, and rebates are the main drivers.

Electric car sales drive cost reductions in batteries, which boosts deployment across all road vehicle categories.

Policies continue to support electric vehicle deployment and are evolving to a more holistic policy portfolio. Environmental and sustainability objectives drive electric vehicle policy support at all governance levels.

Market projections

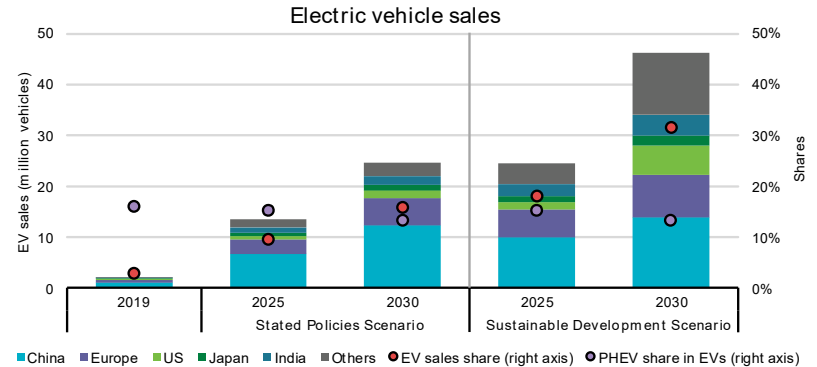

Stated Policy Scenario includes aims to illustrate the likely consequences of existing and announced policy measures.

Sustainable Development Scenario aims at ensuring universal energy access for all by 2030, bringing about sharp reductions in emissions of air pollutants; and meeting global climate goals in line with the Paris Agreement. It is based on limiting the global temperature rise to below 1.7-1.8 degrees Celsius with a 66% probability, reaching net zero emissions by 2070.

Source: [Global EV Outlook 2020](#)

Government regulations, environmental concerns and performance drive shift to EV

Overview of the power train for electric vehicles

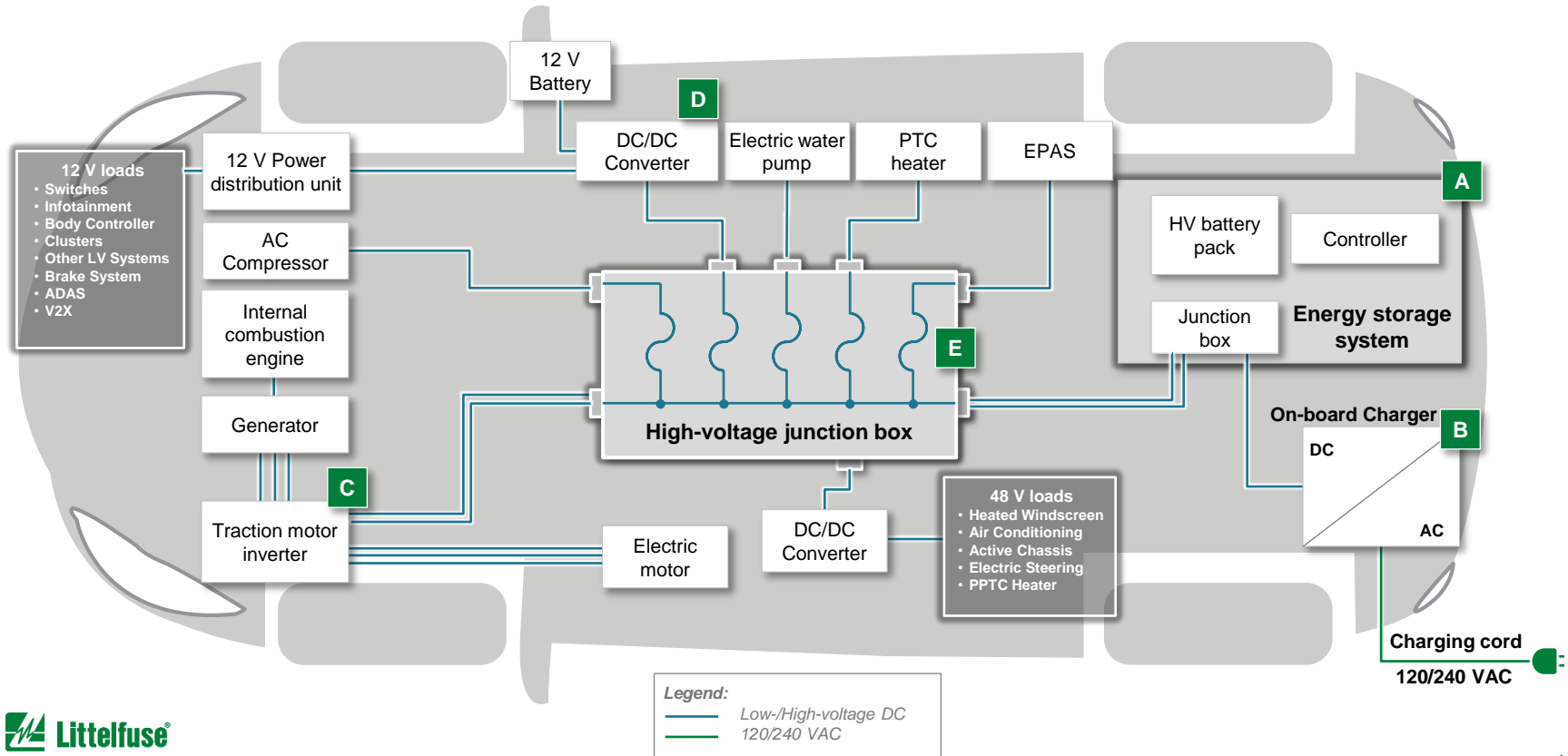

Passenger and commercial EVs share many functional blocks including common power train architectures

A Battery management system

Fuses, TVS Diode,
Gate Driver, Diode Array



B On-board charger

Fuses, MOV,
SIDACtor®, TVS Diode

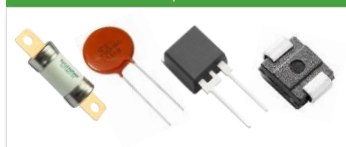

C Traction motor inverter

TVS Diode, Diode Array,
IGBT, Thermal Protector-Mini



D Battery distribution unit

Pre-charge Controller,
Auxiliary Fuse, Pyro Fuse



E DC-DC converter

Fuse, TVS Diode,
Diode Array, Gate Driver

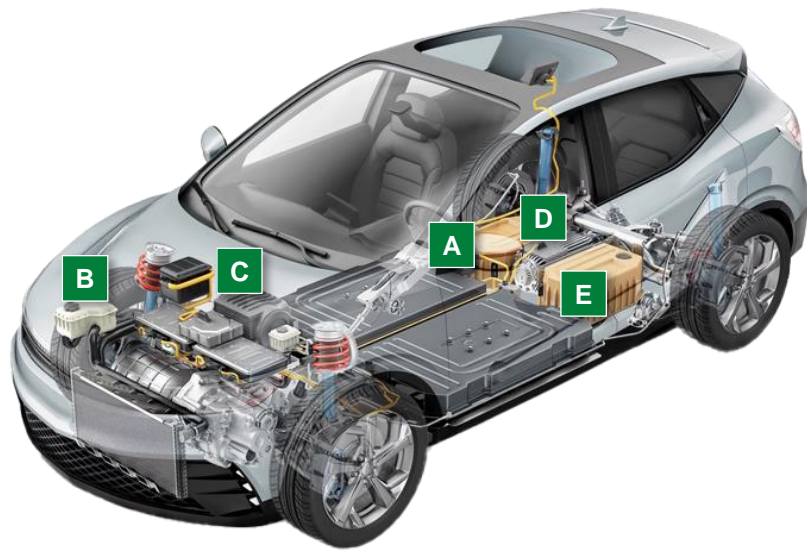
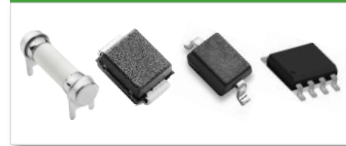

Acronyms:
EV: electric vehicle
TVS: transient voltage suppressor
MOV: metal oxide varistor
IGBT: insulated gate bipolar transistor
DC: direct current



Energy storage system

 Click the product series in the table below for more info

Energy storage system block diagram

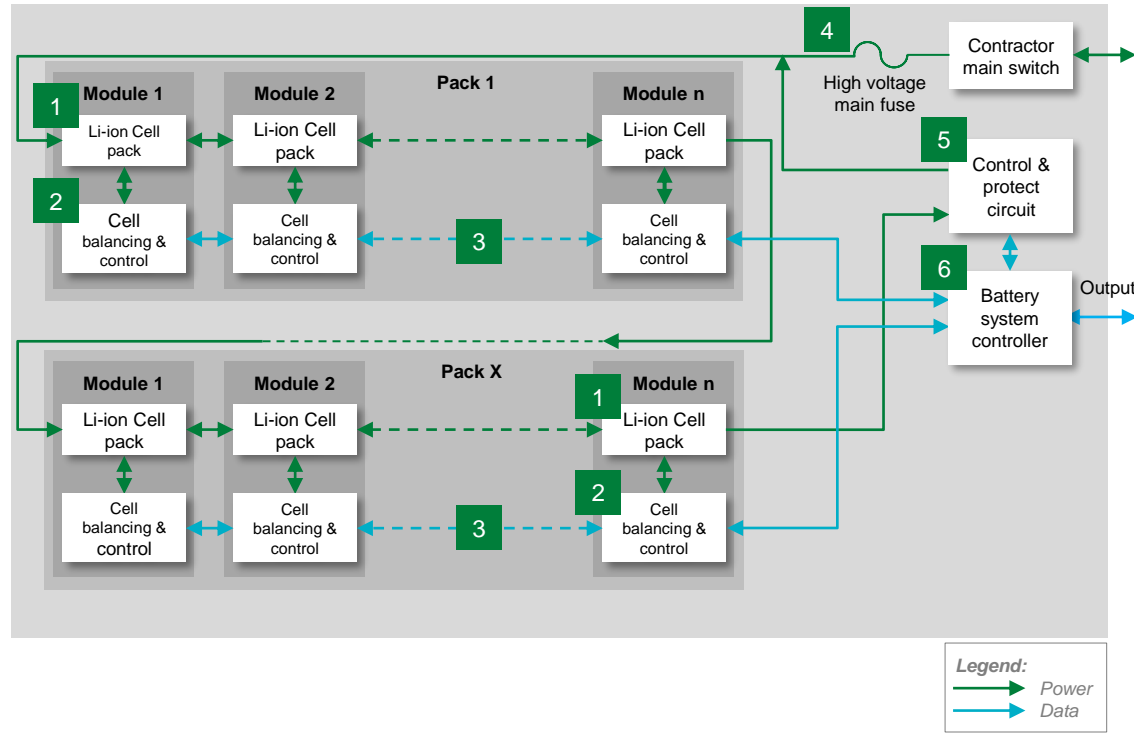

	Technology	Product Series
1	SMD Fuse	501A , 881
	TVS Diode	TPSMC , SZ1SMC , SZ1.5SMC
2	SMD or In-line Fuse	438A , 441A , 521 , 483A
	TVS Diode	TPSMB , SZ1SMB , SZP6SMB
3	Diode Array	AQ05C
	TVS Diode	TPSMA6L , SZ1SMA
4	High-voltage Fuse	30EV1K , 20HEV , 25EV1K
5	Gate Driver	IXD_6xxSI
	Diode Array	AQ24CAN
6	Fuse	885
	TVS Diode	TPSMB , TPSMC

Acronyms:
SMD: surface mount device



Click the product series
in the table below for more info

Potential Littelfuse products for cell/module level protection

	Technology	Function in application	Product series	Benefits	Features
1	SMD Fuse	Protects cells and downstream BMS components from high fault currents due to external shorts	501A , 881	Excellent temperature stability and performance reliability; compact design; ceramic substrate ensures compatibility with high temperature environment	Tested to new AEC-Q specification; fast response to fault current; surface mount device
	TVS Diode	Transient voltage suppression	TPSMC , SZ1SMC , SZ1.5SMC	Excellent clamping capability; meets automotive industry standards; fast response time	AEC-Q101 qualified; meets IEC standards for ESD protection and ISO for in-vehicle transient surges
2	SMD or In-line Fuse	Protects cells and BMS components from overcurrent	438A , 441A , 521 , 483A	Excellent temperature stability and performance reliability; ceramic substrate ensures compatibility with high temperature environment	Tested to new AECQ specification; fast response to fault current; surface mount device
	TVS Diode	Transient voltage suppression	TPSMB , SZ1SMB , SZP6SMB	Excellent clamping capability; meets automotive industry standards; fast response time	AEC-Q101 qualified; meets IEC standards for ESD protection and ISO for in-vehicle transient surges
3	TVS Diode	Transient voltage suppression	AQ05C	Excellent clamping capability; meets automotive industry standards; fast response time	AEC-Q101 qualified; meets IEC standards for ESD protection and ISO for in-vehicle transient surges
	Diode Array	Protects sensitive electronic ICs from ESD, EFT and voltage transient	TPSMA6L , SZ1SMA	Ensures reliability of the equipment without performance degradation	AEC-Q101 qualified; meets ESD protection levels specified under IEC 61000-4-2, ISO10605; low leakage current and clamping voltage
4	High-voltage Fuse	Short circuit protection; overload circuit protection	30EV1K , 20HEV , 25EV1K	Provides safety protection in high-voltage environments; full range fuse	Bolt down form factor; high breaking capacity; ISO 8820 qualified
5	Gate Driver	Controls the switching MOSFETs	JXD_6xxSI	Dual outputs provide space efficient design; high immunity to latch-up; rise/fall times less than 10 ns	Tight tolerance; small form factor; fast thermal response
6	Diode Array	Protects CAN bus from ESD, EFT and voltage transient	AQ24CAN	Ensures reliability of the equipment without performance degradation	AEC-Q101 qualified; meets ESD protection levels specified under IEC 61000-4-2 and ISO10605; low leakage current and clamping voltage
	SMD Fuse	Protects cells and BMS components from over current	885	High voltage SMD form-factor allows compact design; ceramic body ensures compatibility with high temperature environment	Tested to new AEC-Q specification; fast response to fault current; surface mount device
	TVS Diode	Transient voltage suppression	TPSMB , TPSMC	Excellent clamping capability; meets automotive industry standards; fast response time	AEC-Q101 qualified; meets IEC standards for ESD protection and ISO for in-vehicle transient surges

Battery module block diagram

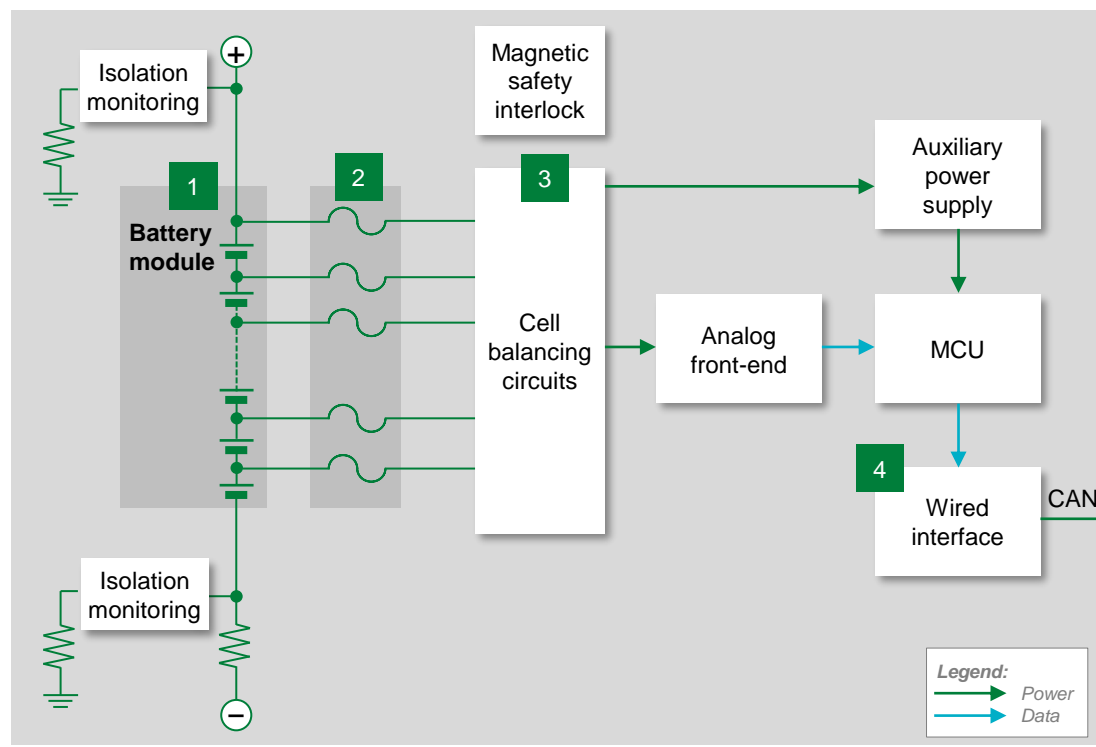

	Technology	Product series
1	HV Fuse	885 , 521
2	LV Fuse	440A , 437A , 438A
3	TVS Diode	TPSMB , SZ1SMB
4	Diode Array	AQ24CANA

Acronyms:
 MCU: microcontroller unit
 CAN: controller area network
 HV: high voltage
 LV: low voltage



Click the product series
in the table below for more info

Protection and sensing solutions for battery packs

	Technology	Function in application	Product series	Benefits	Features
1	HV Fuse	Protects battery pack module and cable from over current	885 , 521	Reduces customer qualification time by complying with third-party safety standards such as ISO	Third-party compliance UL/ISO; low internal resistance; shock safe; vibration resistant
2	LV Fuse	Analog front-end protection of user and environment in case of external short, overload between power-sense line	440A , 437A , 438A	AEC-Q compliant based on inhouse test, reduces customer qualification time by complying with third party safety standards such as UL/IEC; SMD form-factor allows for compact design	Surface mountable; compatible with lead-free solder process per IEC standards; high reliability
3	TVS Diode	Protects sensitive electronic components from voltage transients	TPSMB , SZ1SMB	Improves system reliability by protecting downstream components from transients on power lines	600 W peak pulse capability; compatible with lead-free solder reflow temperature profile
4	Diode Array	Protects CAN bus sensitive electronic ICs from ESD, EFT, and voltage transient	AQ24CANA	Smaller form-factor and multi-line protection enables ease of design	AECQ-101 qualified; low capacitance; low leakage current



On-board charger

On-board charger block diagram

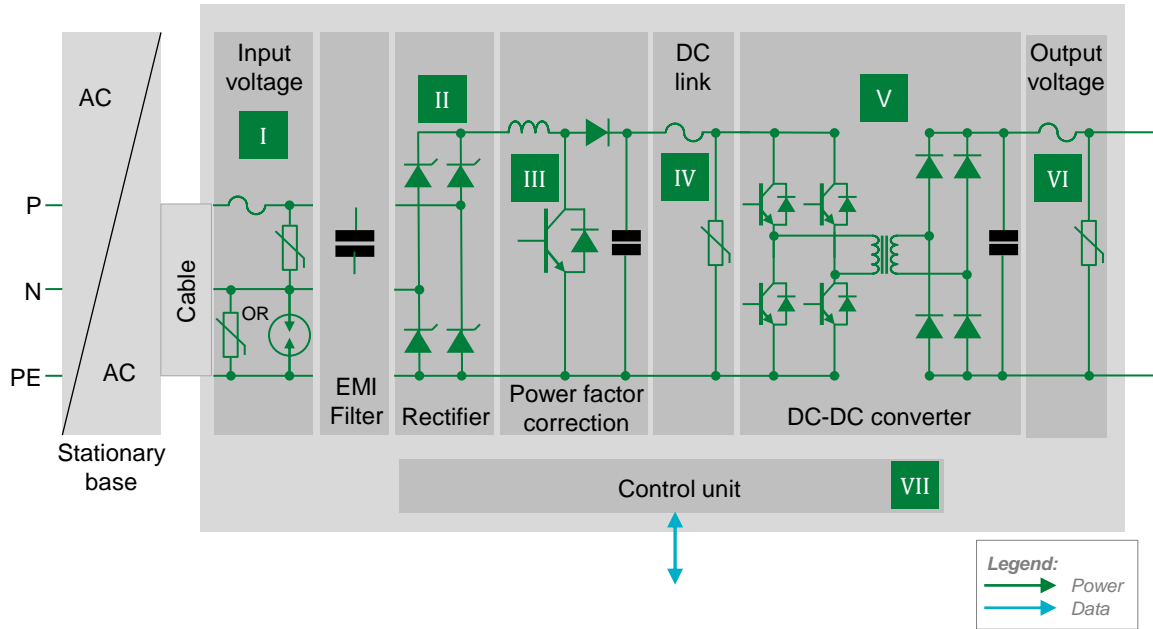

	Technology	Product series
I	Fuse	526 , 527 , 10EV , 20EV
	MOV	AUMOV
	GDT	CG2 , CG3
	SIDACtor®	Pxxx0FNL , Pxxx0SD
II	Thyristor	S8016xA
III	Gate Driver	IXD_6xxSI , IX4340NE
IV	TVS Diode	TPSMB , SZ1SMB , SZP6SMB
	Gate Driver	IXD_6xxSI , IX4340NE
V	TVS Diode	TPSMB , SZ1SMB , SZP6SMB
	Diode Array	AQ4022
VI	Fuse	526 , 527 , 10EV , 20EV , 30EV1K , 25EV1K , 828
	MOV	AUMOV
	TVS Diode	TPSMB , SZ1SMB , SZP6SMB
VII	Diode Array	AQ24CANA



Click the product series
in the table below for more info

Benefits of Littelfuse products in on-board charger

	Technology	Function in application	Product series	Benefits	Features
I	Fuse	Short circuit protection; overload circuit protection	526 , 527 , 10EV , 20EV	Provides safety protection in high-voltage environments; full range fuse	Bolt down form factor; high breaking capacity; qualified to ISO 8820 standard
	MOV	Lightning and system transient surges	AUMOV	Clamps transient surge to ensure the reliable performance of the circuitry	Wide range of surge current ratings; disk sizes and lead options
	GDT	Ensures electrical isolation between line, neutral, and ground	CG2 , CG3	Provides safety to the system with high resistance isolation	Rugged, high surge current based on ceramic tube design; low leakage current
	SIDACtor®	Lightning and system transient surges	Pxx0FNL , Pxx0SD	Used in combination with MOV; provides lower clamping voltage for sensitive circuitry	Surface mount form factor; semiconductor-based design provides no wear-out capability
II	Thyristor	Rectification	S8016xA	Reduces the in-rush current during rectification that can damage expensive DC link capacitor	Compact TO-220AQ and surface mount TO-263 form factors, V_{DRM} of 800 V, I_t of 25 A (rms)
III	Gate Driver	Controls the switching MOSFETs	IXD 6xxSI , IX4340NE	Dual outputs provide space efficient design; high immunity to latch-up; rise/fall times less than 10 ns	Tight tolerance, small form factor; fast thermal response.
IV	TVS Diode	Active clamping	TPSMB , SZ1SMB , SZP6SMB	Clamps the transient that is created when the MOSFET switches; ensuring reliability	Small form factor DO214-AA package; low clamping voltage
V	Gate Driver	Controls the switching MOSFETs	IXD 6xxSI , IX4340NE	Dual outputs provide space efficient design; high immunity to latch-up; rise/fall times less than 10 ns	Tight tolerance; small form factor; fast thermal response
	TVS Diode	Active clamping	TPSMB , SZ1SMB , SZP6SMB	Clamps the transient that is created when the MOSFET switches; ensuring reliability	Small form factor DO214-AA package; low clamping voltage
	Diode Array	ESD protection of the gate input	AQ4022	Ensures reliability of the equipment without performance degradation	AEC-Q101 qualified; meets ESD protection levels specified under IEC 61000-4-2 and ISO10605; low leakage current and clamping voltage
VI	Fuse	Short circuit protection Overload circuit protection	526 , 527 , 10EV , 20EV , 30EV1K , 25EV1K , 828	Provides safety protection in high-voltage environments; full range fuse	Bolt down form factor, high breaking capacity; qualified to ISO 8820 standard
	MOV	Transient voltage suppression	AUMOV	Clamps transient surge to ensure the reliable performance of the circuitry	Wide range of surge current ratings; disk sizes and lead options
	TVS Diode	transient voltage suppression	TPSMB , SZ1SMB , SZP6SMB	Excellent clamping capability; meets automotive industry standards; fast response time	AEC-Q101 qualified; meets IEC standards for ESD protection and ISO for in-vehicle transient surges
VII	Diode Array	Protects CAN bus from ESD, EFT, and voltage transient	AQ24CANA	Ensures reliability of the equipment without performance degradation	AEC-Q101 qualified; meets ESD protection levels specified under IEC 61000-4-2, ISO10605; low leakage current and clamping voltage



Traction motor inverter

Traction motor inverter block diagram

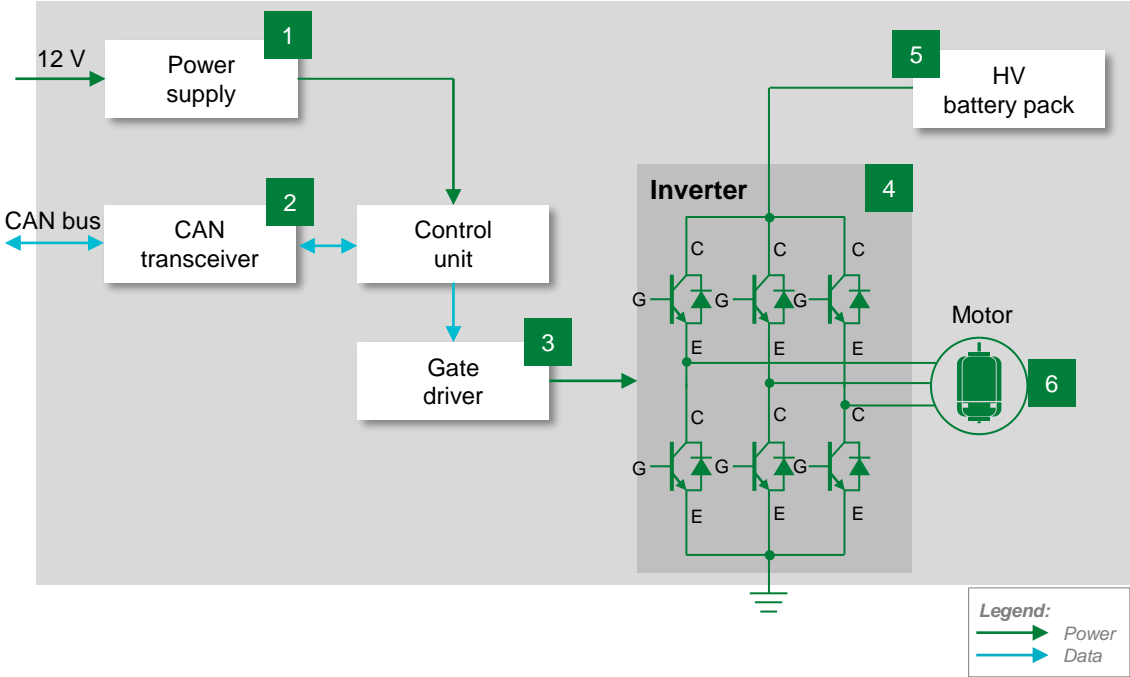

	Technology	Product series
1	TVS Diode	TPSMB , TPSMA6L , SZ1SMB , SZP6SMB , SZ1SMA
	Fuse	441A
2	TVS Diode Array	AQ24CANA
3	Diode Array	AQ4022
	IGBT Gate Driver	IXD_6xxSI , IX4340NE
4	TVS Diode	TPSMB , SZ1SMB , SZP6SMB
5	Fuse	526 , 527 , 30EV1K , 25EV1K , 828
6	TVS Diode	TPSMB
	Thermal Protector Mini	HCRTP-mini

Benefits of Littelfuse products in traction motor inverter



Click the product series in the table below for more info

	Technology	Function in application	Product series	Benefits	Features
1	TVS Diode	Transient voltage suppression	TPSMB , TPSMA6L , SZ1SMB , SZP6SMB , SZ1SMA	Excellent clamping capability; meets automotive industry standards; fast response time; compact design	AEC-Q101 qualified; meets IEC standards for ESD protection and ISO for in-vehicle transient surges
	Fuse	Short circuit protection overload circuit protection	441A	Excellent temperature stability and performance reliability; compact design; ceramic substrate ensures compatibility with high temperature environment	Tested to new AECQ specification; fast response to fault current; surface mount device
2	Diode Array	Protect CAN bus from ESD, EFT, and voltage transient	AQ24CANA	Ensures reliability of the equipment without performance degradation	AEC-Q101 qualified; meets ESD protection levels specified under IEC 61000-4-2, ISO10605; low leakage current and clamping voltage
3	Diode Array	ESD protection of the gate input	AQ4022	Ensures reliability of the equipment without performance degradation	AEC-Q101 qualified; meets ESD protection levels specified under IEC 61000-4-2, ISO10605; low leakage current and clamping voltage
	TVS Diode	Transient voltage suppression	TPSMF4L , SZSMF	Excellent clamping capability; meets automotive industry standards; fast response time; compact design	AEC-Q101 qualified; meets IEC standards for ESD protection and ISO for in-vehicle transient surges
	IGBT Gate Driver	Controls the switching MOSFETs	IXD_6xxSI , IX4340NE	Dual outputs provide space efficient design; high immunity to latch-up; rise/fall times less than 10 ns	Tight tolerance; small form factor; fast thermal response
4	TVS Diode	Active clamping	TPSMB , SZ1SMB , SZP6SMB	Clamps the transient that is created when the MOSFET switches; ensuring reliability	Small form factor DO214-AA package; low clamping voltage
5	Fuse	Short circuit protection	526 , 527 , 30EV1K , 25EV1K , 828	Provides safety protection from short circuit conditions	High voltage; ceramic body ensures compatibility with high temperature environment
6	TVS Diode	Transient voltage suppression	TPSMB	Excellent clamping capability; meets automotive industry standards; fast response time	AEC-Q101 qualified; meets IEC standards for ESD protection and ISO for in-vehicle transient surges
	Thermal Protection Mini	Thermal protection for MOSFETs	HCRTP-mini	Responds to over-temperature conditions caused by catastrophic failure of MOSFET device	Surface mountable form factor; compatible with standard reflow process; breaks current flow during overtemperature condition



DC-DC converter



Click the product series
in the table below for more info

DC-DC converter block diagram

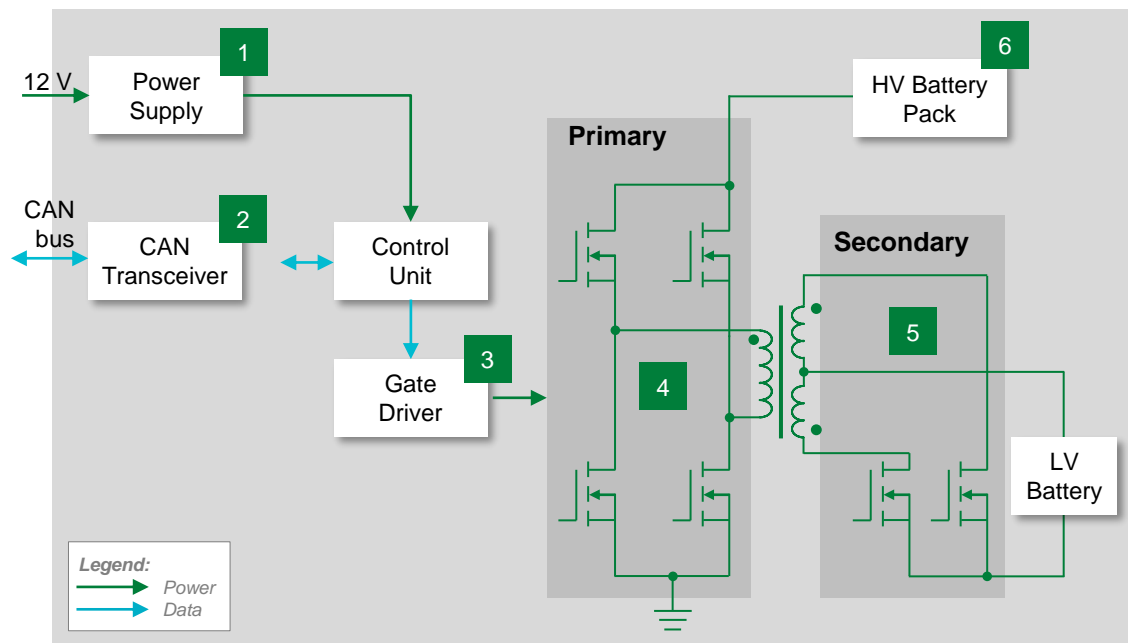

	Technology	Product series
1	TVS Diode	TPSMB , TPSMA6L , SZ1SMB , SZP6SMB , SZ1SMA
	Fuse	441A
	Thermal Protector	HCRTP-mini
2	Diode Array	AQ24CANA
	Diode Array	AQ4022
3	TVS Diode	TPSMF4L
	Gate Driver	IXD 6xxSI , IX4340NE
4	TVS Diode	TPSMB , SZ1SMB , SZP6SMB
	Fuse	526 , 527 , 30EV1K , 25EV1K , 828
5	Thermal Protector	HCRTP-mini
	TVS Diode	TPSMB , SZ1SMB , SZP6SMB
6	Gate Driver	IXD 6xxSI , IX4340NE



Benefits of Littelfuse products in DC-DC converter

	Technology	Function in application	Product series	Benefits	Features
1	TVS Diode	Transient voltage suppression	TPSMB , TPSMA6L , SZ1SMB , SZP6SMB , SZ1SMA	Excellent clamping capability; meets automotive industry standards; fast response time; compact design	AEC-Q101 qualified; meets IEC standards for ESD protection and ISO for in-vehicle transient surges
	Fuse	Short circuit and overload circuit protection	441A	Excellent temperature stability and performance reliability; ceramic substrate ensures compatibility with high temperature environment	Tested to new AECQ specification; fast response to fault current; surface mount device
	Thermal Protection	Thermal protection for MOSFETs	HCRTP-mini	Responds to over-temperature conditions caused by catastrophic failure of MOSFET device	Surface mountable form factor; compatible with standard reflow process; breaks current flow during overtemperature condition
2	Diode Array	Protects CAN bus from ESD, EFT, and voltage transient	AQ24CANA	Ensures reliability of the equipment without performance degradation	AEC-Q101 qualified; meets ESD protection levels specified under IEC 61000-4-2 and ISO10605; low leakage current and clamping voltage
3	Diode Array	ESD protection of the gate input	AQ4022	Ensures reliability of the equipment without performance degradation	AEC-Q101 qualified; meets ESD protection levels specified under IEC 61000-4-2 and ISO10605; low leakage current and clamping voltage
	TVS Diode Array	Transient voltage suppression	TPSMF4L	Excellent clamping capability; meets automotive industry standards; fast response time	AEC-Q101 qualified; meets IEC standards for ESD protection and ISO for in-vehicle transient surges
	Gate Driver	Controls the switching MOSFETs	IXD_6xxSI , IX4340NE	Dual outputs provide space efficient design; high immunity to latch-up; rise/fall times less than 10 ns	Tight tolerance; small form factor; fast thermal response
4	TVS Diode	Active clamping	TPSMB , SZ1SMB , SZP6SMB	Clamps the transient that is created when the MOSFET switches; ensuring reliability	Small form factor DO214-AA package; low clamping voltage
5	Fuse	Short circuit protection	526 , 527 , 30EV1K , 25EV1K , 828	Provides safety protection from short circuit conditions	High voltage; ceramic body ensures compatibility with high temperature environment
	Thermal Protection	Thermal protection for MOSFETs	HCRTP-mini	Responds to over-temperature conditions caused by catastrophic failure of MOSFET device	Surface mountable form factor; compatible with standard reflow process; breaks current flow during overtemperature condition
6	TVS Diode	Active clamping	TPSMB , SZ1SMB , SZP6SMB	Clamps the transient that is created when the MOSFET switches; ensuring reliability	Small form factor DO214-AA package; low clamping voltage
	Gate Driver	Controls the switching MOSFETs	IXD_6xxSI , IX4340NE	Dual outputs provide space efficient design; high immunity to latch-up; rise/fall times less than 10 ns	Tight tolerance; small form factor; fast thermal response



Battery distribution unit



Click the product series
in the table below for more info

Battery distribution unit block diagram

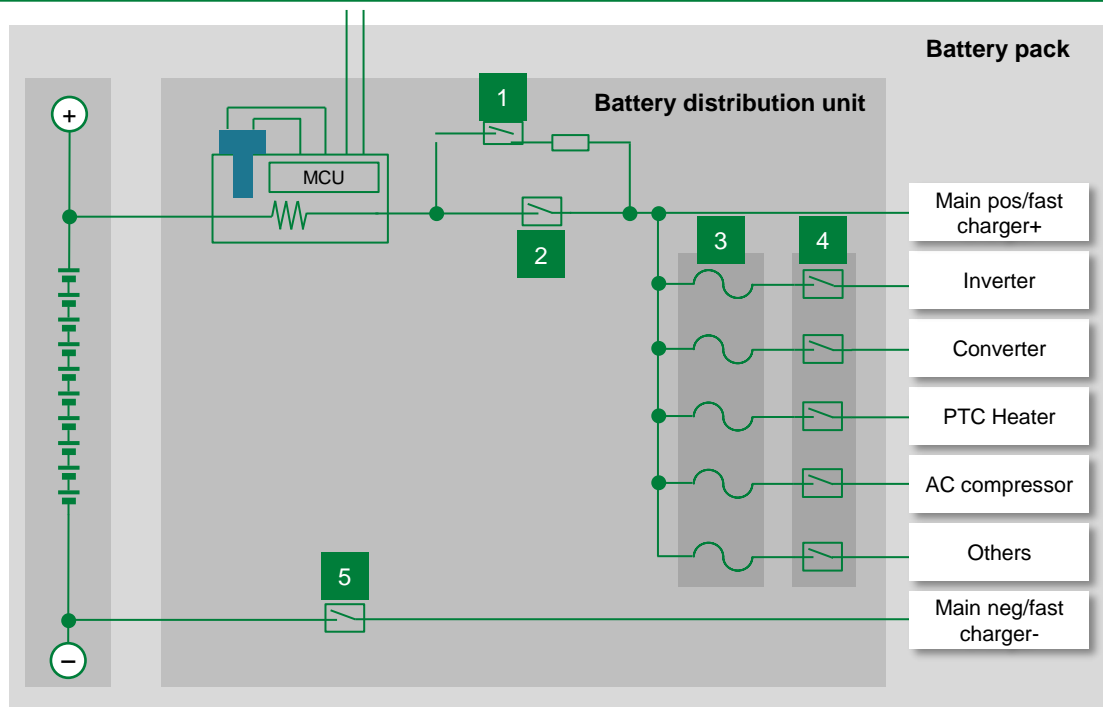

	Technology	Product series
1	High Voltage DC Contactor	DCNHR
2	High Voltage DC Contactor	DCNHR
3	Auxiliary Fuse	10EV , 20EV , SHEV , EV1K , 526 , 828
4	High Voltage DC Contactor	DCNHR
5	High Voltage DC Contactor	DCNHR

Benefits of Littelfuse products in battery distribution unit



Click the product series in the table below for more info

	Technology	Function in application	Product series	Benefits	Features
1	High Voltage DC Contactor	Used to protect the main contactors from an excess inrush current, a pre-charge contactor is used together with a pre-charge resistor to charge the capacitors of the power inverter to a level of typically 90–98% of the battery voltage	DCNHR	Allows a low-voltage signal to switch the contacts for a high voltage signal	Wide amperage rating 30–100 A; gas-filled contact chamber and magnetic blowouts for arc suppression; available direct switched auxiliary circuit for status indication
2	High Voltage DC Contactor	The main contactors connect and disconnect the traction battery from the entire electric drivetrain in the vehicle	DCNHR	Allows a low voltage signal to switch the contacts for a high-voltage signal	Wide amperage rating 100–500 A; gas-filled contact chamber and magnetic blowouts for arc suppression; integrated coil economizer included in many models; available direct switched auxiliary circuit for status indication
3	Auxiliary Fuse	Short circuit protection; overload circuit protection	10EV , 20EV , SHEV , EV1K , 526 , 828	Provides safety protection in high-voltage environments, full range fuse; can protect the entire pack's voltage and short circuit current	Bolt-down form factor; high breaking capacity; qualified to ISO 8820 standard
4	High Voltage DC Contactor	Control other electrical loads in the vehicle that are operated by the HV battery (for example, electric heater, blower, AC compressor, power steering pump, and so on)	DCNHR	Allows a low voltage signal to switch the contacts for a high-voltage signal	Wide amperage rating 100–500 A; gas-filled contact chamber and magnetic blowouts for arc suppression; integrated coil economizer included in many models; available direct switched auxiliary circuit for status indication
5	High Voltage DC Contactor	The main contactors connect and disconnect the traction battery from the entire electric drivetrain in the vehicle	DCNHR	Allows a low voltage signal to switch the contacts for a high-voltage signal	Wide amperage rating 100–500 A; gas-filled contact chamber and magnetic blowouts for arc suppression; integrated coil economizer included in many models; available direct switched auxiliary circuit for status indication

Select standards for automotive applications

Standard	Title	General scope	Littelfuse technology	Region
ISO7637-2	Road vehicles – Electrical disturbances from conduction and coupling – Part 2: Electrical transient conduction along supply lines only	Specifies test methods and procedures to ensure the compatibility to conducted electrical transients of equipment installed on passenger cars and commercial vehicles fitted with 12 V or 24 V electrical systems. It describes bench tests for both the injection and measurement of transients. It is applicable to all types of road vehicles independent of the propulsion system (For example, spark ignition or diesel engine, and electric motor).	TVS Diode	Global
ISO16750-2	Road vehicles – Environmental conditions and testing for electrical and electronic equipment – Part 2: Electrical loads	This standard applies to electric and electronic systems/components for road vehicles. It describes the potential environmental stresses and specifies tests and requirements recommended for the specific mounting location on/in the road vehicle.	TVS Diode	Global
ISO 10605:2008	Road vehicles – Test methods for electrical disturbances from electrostatic discharge	This standard specifies the electrostatic discharge (ESD) test methods necessary to evaluate electronic modules intended for vehicle use. It includes these sources of ESD: in assembly, by service staff, by vehicle occupants.	Diode Array PulseGuard (AXGD) Multilayer Varistor	Global

Additional information can be found on Littelfuse.com

Explore the world of Littelfuse with the electronics eCatalogs (electronicscatalogs.littelfuse.com)



Circuit Protection Selection Guide

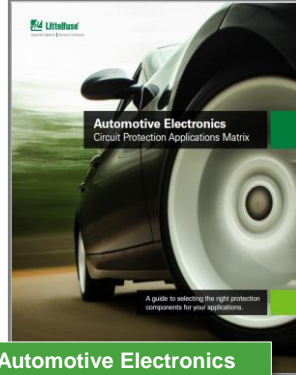

Automotive Electronics Application Guide



ESD Suppression Selection Guide



ESD Protection Selection Guide

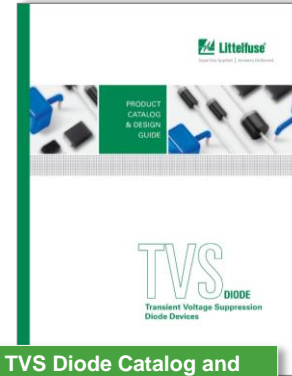
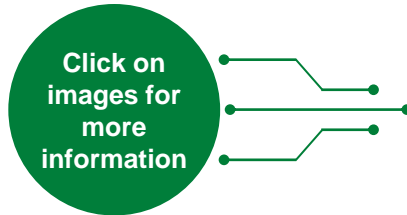

TVS Diode Catalog and Design Guide

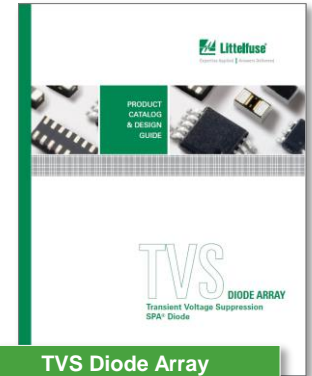

TVS Diode Array Selection Guide

Local resources supporting our global customers

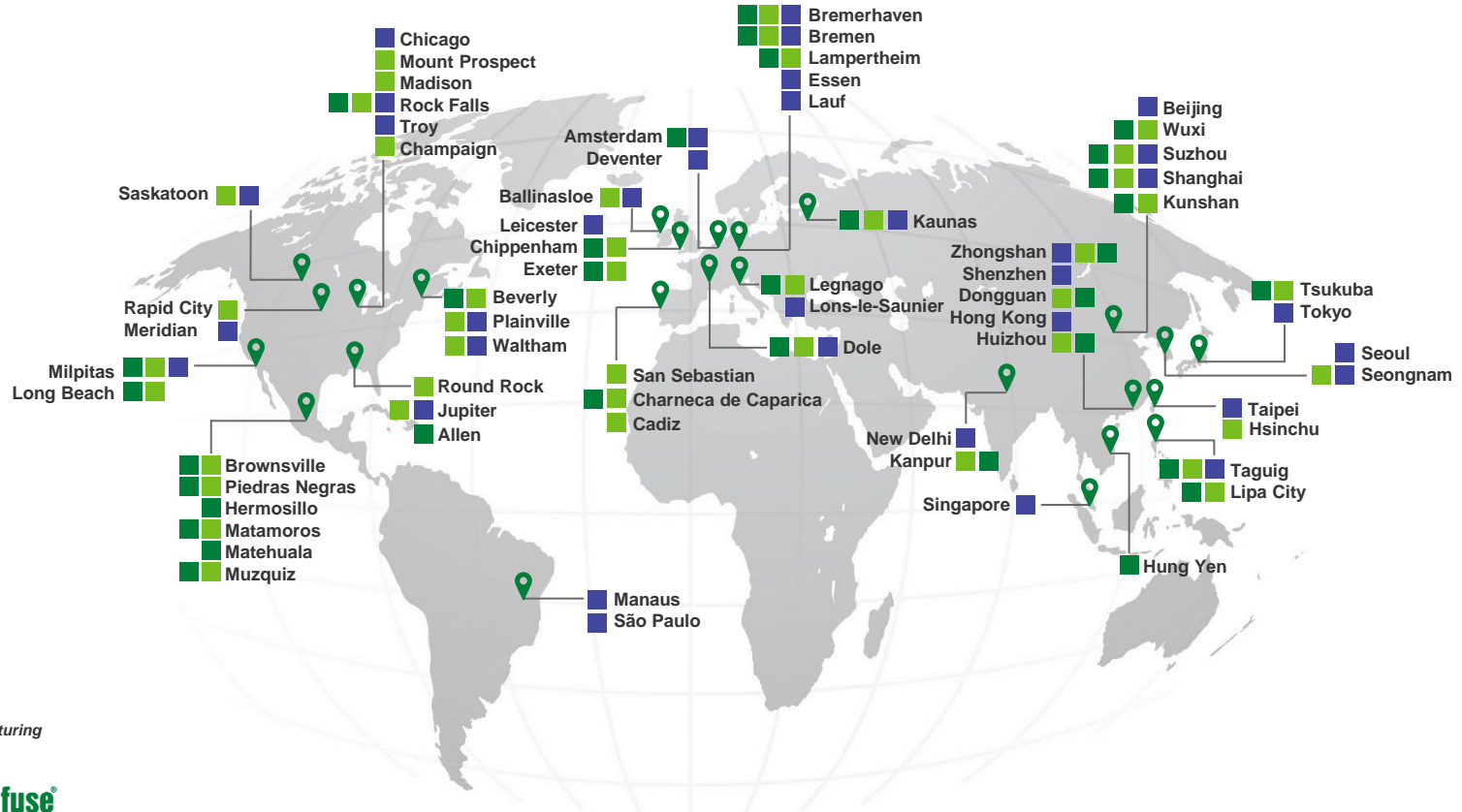

Legend

- Sales
- R&D
- Manufacturing

Partner for tomorrow's electronic systems

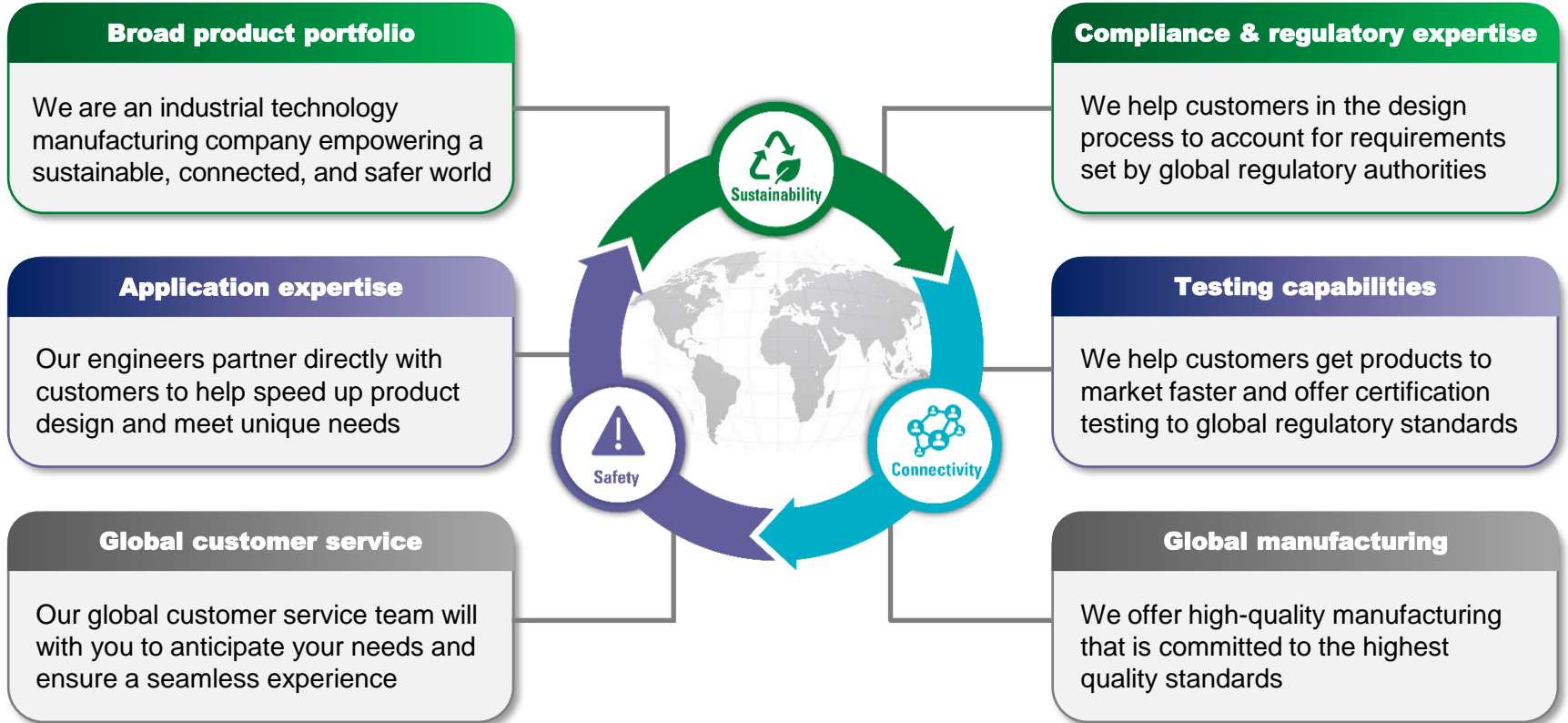



Expertise Applied | Answers Delivered

Littelfuse.com

This document is provided by Littelfuse, Inc. ("Littelfuse") for informational and guideline purposes only. Littelfuse assumes no liability for errors or omissions in this document or for any of the information contained herein. Information is provided on an "as is" and "with all faults" basis for evaluation purposes only. Applications described are for illustrative purposes only and Littelfuse makes no representation that such applications will be suitable for the customer's specific use without further testing or modification. Littelfuse expressly disclaims all warranties, whether express, implied or statutory, including but not limited to the implied warranties of merchantability and fitness for a particular purpose, and non-infringement. It is the customer's sole responsibility to determine suitability for a particular system or use based on their own performance criteria, conditions, specific application, compatibility with other components, and environmental conditions. Customers must independently provide appropriate design and operating safeguards to minimize any risks associated with their applications and products. Read complete Disclaimer Notice at: www.littelfuse.com/disclaimer-electronics.