



Expertise Applied | Answers Delivered



setP™

## Digital Temperature Indicators for USB Type-C Cables

Design and Installation Guide



# setP Design and Installation Guide

## Contents

| Topic   | Page |
|---|------|
| <b>Sections</b>   |      |
| 1.0 Description of Risks and Hazards                                | 3    |
| 2.0 Theory of Operation   | 3    |
| 3.0 Placement Inside the Plug                                       | 4    |
| 4.0 Soldering Parameters  | 4    |
| 5.0 Overmolding Process Guidance                                    | 5    |
| 6.0 Testing Methods   | 5    |
| 6.1 Testing Method: Design Verification                             | 6    |
| 6.2 Testing Method: Quality Assurance                               | 8    |
| 7.0 Part Numbering and Selection Guidance                           | 8    |
| <b>Figures</b>  |      |
| 1 USB Full-Featured Type-C Plug Interface (Front View)              | 3    |
| 2 setP Placement Within Charging System                             | 3    |
| 3 setP Location Recommendation                                      | 4    |
| 4 Temperature Location Example                                      | 4    |
| 5 Soldering Parameters  | 5    |
| 6 Recommended Solder Pad Layout                                     | 5    |
| 7 Design Verification Method 1, Test Setup                          | 6    |
| 8 Design Verification Method 2, Test Setup                          | 7    |
| 9 USB Type-C to Type-C Cable Quality Assurance Test                 | 8    |
| 10 USB Type-C to Open Cable Quality Assurance Test                  | 8    |
| A1 Sink Monitoring for Current in Current Source/Pull-down CC Model | 10   |
| A2 Sink Monitoring for Current in Pull-up/Pull-down CC Model        | 10   |
| C1 setP Eye Diagram   | 10   |
| C2 Surface Temperatures During Overheating Test                     | 11   |
| D1 setP Resistance vs. Temperature Curve                            | 11   |
| <b>Tables</b>   |      |
| 1 Soldering Parameters  | 4    |
| 2 Contamination Test Board Resistor Values                          | 7    |
| A1 Electrical Requirements for CC and SBU Wires                     | 9    |
| A2 CC Voltage vs. Power Level                                       | 9    |
| <b>Appendices</b>   |      |
| A Power Negotiation Over CC Line of USB Type-C                      | 9    |
| B Applicable Standards  | 10   |
| C setP Protection Verification                                      | 10   |
| D Source Advertisement vs. Trip Temperature                         | 11   |



## 1.0 Description of Risks and Hazards

Power levels of up to 100W and small pin-to-pin spacing make the risk of dangerous overheating quite high for USB Type-C devices and the cables used to charge them.

Environmental factors can also lead to equipment overheating. Dust, dirt, lint, water, and other liquids are just a few examples of environmental conditions that can lead to failure.

Mechanical failures such as bent pins or worn cables may lead to overcurrent events. Other mechanical failures may lead to worn-out devices; over time, these worn-out devices can also become the source of heat, eventually leading to failure.

## 2.0 Theory of Operation

USB Type-C uses a configuration process over the Configuration Channel, usually referred to as the CC pin. In the USB Type-C plug interface illustrated in Figure 1, this is pin A5. The configuration process is used to confirm multiple items, including:

- Attachment or detachment of the cable
- Plug orientation
- Agreement of power to be delivered over the cable

|     |      |      |                  |                   |    |    |      |                  |      |      |     |
|-----|------|------|------------------|-------------------|----|----|------|------------------|------|------|-----|
| A12 | A11  | A10  | A9               | A8                | A7 | A6 | A5   | A4               | A3   | A2   | A1  |
| GND | RX2+ | RX2- | V <sub>BUS</sub> | SBU1              | D- | D+ | CC   | V <sub>BUS</sub> | TX1- | TX1+ | GND |
|     |      |      |                  |                   |    |    |      |                  |      |      |     |
| GND | TX2+ | TX2- | V <sub>BUS</sub> | V <sub>CONN</sub> |    |    | SBU2 | V <sub>BUS</sub> | RX1- | RX1+ | GND |
| B1  | B2   | B3   | B4               | B5                | B6 | B7 | B8   | B9               | B10  | B11  | B12 |

Figure 1. USB full-featured Type-C plug interface (front view)<sup>1</sup>

Using a pull-up resistor ( $R_p$ ) in the Source and a pull-down resistor ( $R_d$ ) in the Sink, the source measures the voltage on the CC pin to determine if the Sink is attached or not. When the voltage is higher than a specific value, the Source “knows” that no Sink is attached. When there is no connection, the Source will keep  $V_{BUS}$  off (pins A9, B4, A4, and B9). The “No Connection” voltage is defined in the USB Type-C Cable and Connector Specification as “vOpen”. Appendix A provides further details on the power negotiation process.

A setP digital temperature indicator is designed to be placed inside the plug, onto the CC line, as shown in Figure 2. The setP device senses heat, which causes its resistance to rise and thereby increase the voltage present on the CC line. The CC line’s increased voltage causes the system to assume there is no connection, so the system turns  $V_{BUS}$  power off.

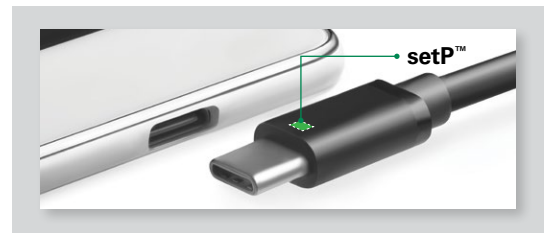

Figure 2. setP placement within charging system

<sup>1</sup> Source: USB Type-C Cable and Connector Specification Release 1.4

### 3.0 Placement Inside the Plug

Centering the setP device on the printed circuit board (PCB) as close to the connector mounting pins as possible will provide the best protection performance.

In accordance with the electrical creepage and clearance guidelines within IPC-2221A, Section 6.3.7, the setP device should be no closer than 0.25 mm to components without conformal coating and no closer than 0.13 mm for components with conformal coating. Figure 3 illustrates the recommended placement.

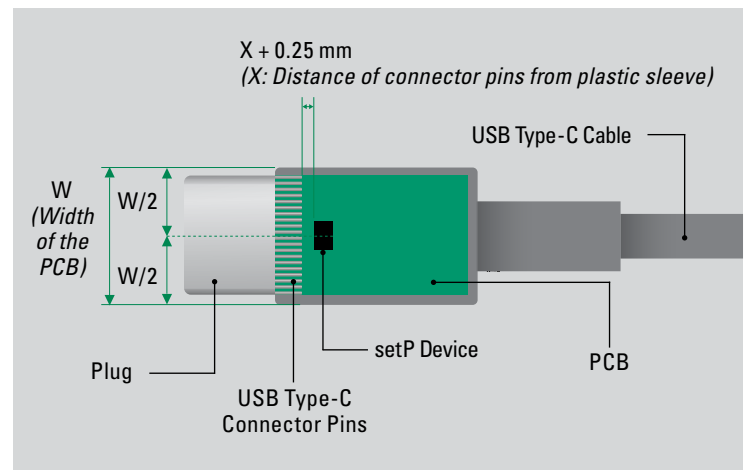

Figure 3. setP location recommendation

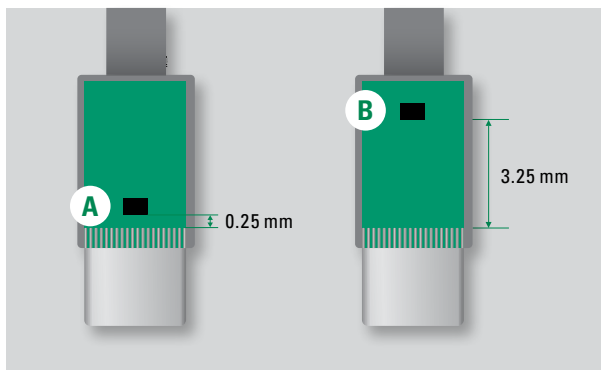

Figure 4. Temperature location example

Littelfuse advises locating a setP device no further than 3 mm from the pins of the connector. Testing to determine how temperature changes for various setP placement locations on the PCB indicates that for every 1 mm further from the connector, the temperature decreases ~5° C.

For example, while the temperature at location A (Figure 4) reaches 100°C, the temperature at location B would be 85° C.

The thermal response during a fault situation will vary depending on the materials selected and other factors related to the overall design. Testing can help determine the optimal placement of the setP device for each design.

### 4.0 Soldering Parameters

This section provides soldering parameters and the recommended circuit board pad.

| Profile Feature  | Average Ramp-Up Rate ( $T_{S_{max}}$ to $T_p$ ) | Pre Heat                          |                                   |   | Time Maintained Above |                       | Peak / Classification Temperature ( $T_p$ ) | Time Within 5° C of Actual Peak Temperature ( $t_p$ ) | Ramp down Rate | Time 25° C to Peak Temperature |
|------------------|---|-----------------------------------|-----------------------------------|---|-----------------------|-----------------------|---|---|----------------|--------------------------------|
|                  |   | Temperature Min ( $T_{S_{min}}$ ) | Temperature Max ( $T_{S_{max}}$ ) | Time ( $t_{S_{min}}$ to $t_{S_{max}}$ ) | Temperature ( $T_L$ ) | Temperature ( $t_L$ ) |   |   |                |                                |
| Pb-Free Assembly | 3° C/s Max                                      | 150° C                            | 200° C                            | 60 – 120s                               | 217° C                | 60 – 150s             | 260° C                                      | 30s Max   | 2° C/s Max     | 8 Mins Max                     |

Table 1. Soldering Parameters

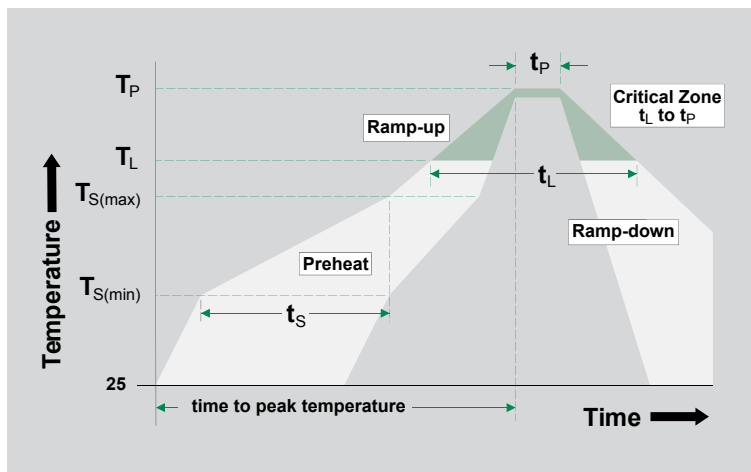

Figure 5. Soldering parameters

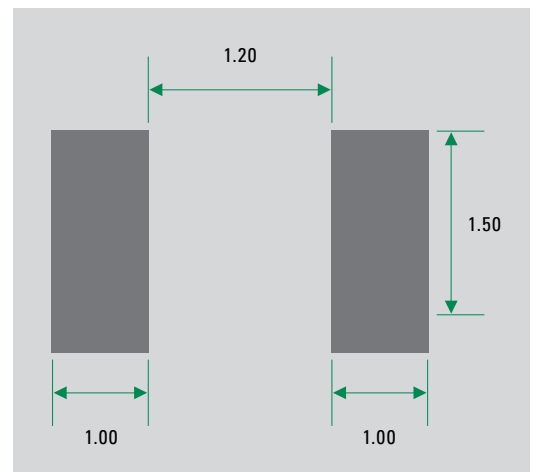

Figure 6. Recommended solder pad layout

#### Soldering profile notes:

- All temperatures refer to topside of the package, measured on the package body surface
- If reflow temperature exceeds the recommended profile, devices may not meet the performance requirements
- Recommended reflow methods: IR, vapor phase oven, hot air oven, N2 environment
- Recommended maximum paste thickness is 0.25 mm (0.010 inch)
- Devices can be cleaned using standard industry methods and aqueous solvents
- Devices can be reworked using the standard industry practices. (Avoid contact to the device.)

## 5.0 Overmolding Process Guidance

A setP device is constructed much like other resistors and capacitors commonly used on PCBs. It is compatible with most modern cable assembly processes, which typically include an inner-mold to enclose and protect the PCB prior to further assembly of a metal shield and an outer mold. Littelfuse has evaluated setP devices for use with polypropylene materials, which require an injection pressure of 400 psi. For assistance with other materials and molding processes, contact Littelfuse.

## 6.0 Testing Methods

Testing of the protection is performed for two primary reasons.

- Design Verification: To verify the design and confirm the protection works as intended during simulated fault conditions. This type of testing could degrade or damage the cable, so it is only performed on a statistically significant quantity of samples from the general cable population.
- Quality Assurance: To verify proper assembly of the cable. It is often desirable to test the assembly quality, for all products. This testing should be non-destructive, given that it will be performed on product being sold to consumers.

The following testing outline addresses these two primary objectives.

## 6.1 Testing Method: Design Verification

Applying heat externally to a cable with a setP device inside is often done to validate that a design provides the intended protection. Two test methods are commonly used.

- Design Verification Test Method 1: External heat from a thermal chamber (Figure 7)
  - 1 Connect the USB-C cable with setP inside to a USB-C Source, a USB-C extension cable, a USB-C test board, power meter, and a USB-C sink.
  - 2 Measure and record the  $V_{BUS}$  voltage via the USB-C test board.
  - 3 Put the mated connectors (USB-C plug + receptacle) into a thermal chamber.
  - 4 Raise the thermal chamber temperature at the rate of 1°C per minute.
  - 5 Measure and record the thermal chamber temperature via a thermocouple sensor.
  - 6 When  $V_{BUS}$  voltage is observed turning off, turn off the thermal chamber and let the temperature drop naturally.
  - 7 When  $V_{BUS}$  voltage is observed turning back on, the test is complete.
  - 8 Pass/fail evaluation: Pass =  $V_{BUS}$  voltage observed to be off during step 6. The  $V_{BUS}$  voltage is observed to be on during step 7.

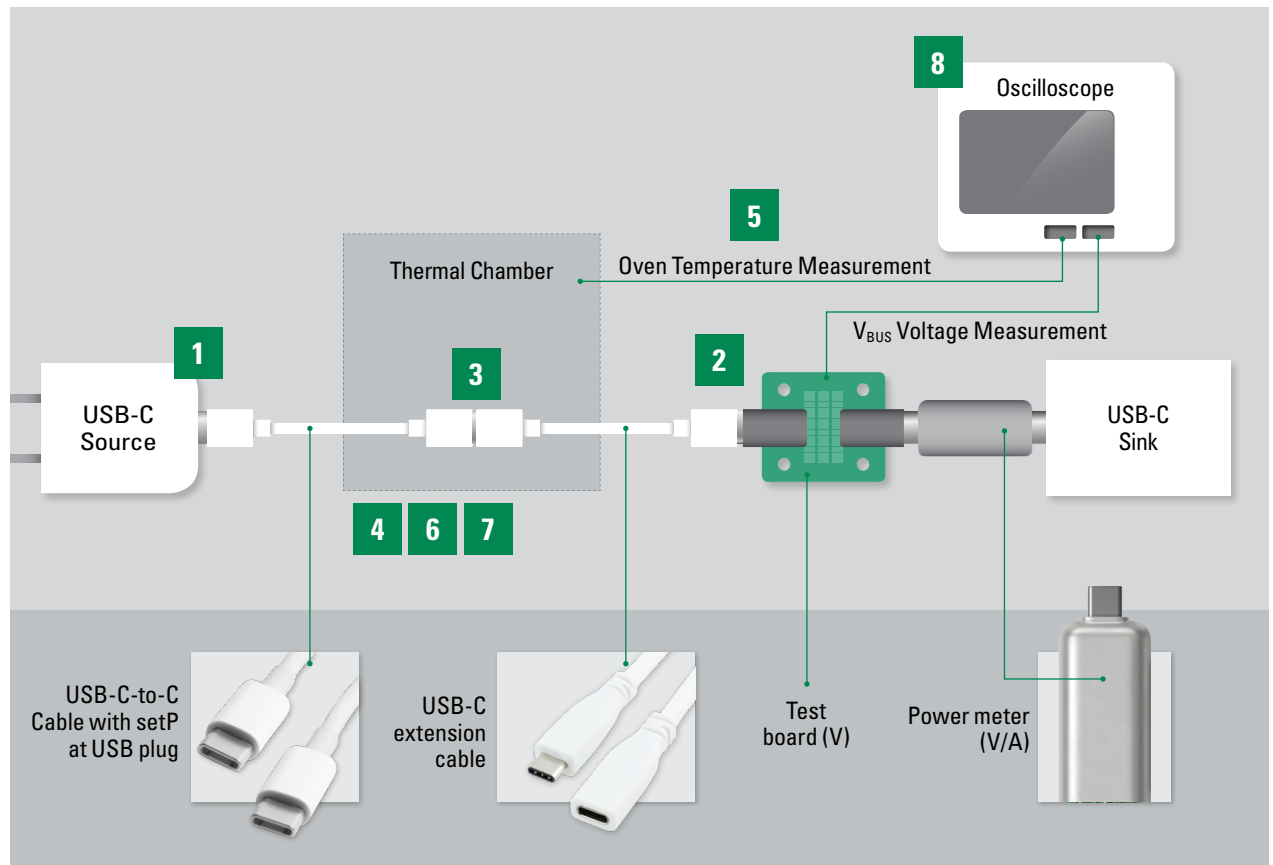

Figure 7. Design verification method 1 test setup

■ Design Verification Test Method 2: Contamination fault simulation test board (Figure 8)

- 1 Connect the USB-C cable with setP inside to a USB-C Source, a USB-C extension cable, a fault simulation board, power meter, and a USB-C sink. (Contact Littelfuse for details on the fault simulation board.)
- 2 As soon as USB-C Source is connected to a power supply, the fault simulation test board will start generating heat, resulting in the USB-C cable with a setP device heating up.
- 3 Measure and record the  $V_{BUS-Gnd}$  voltage via the test board and the temperature of the cable outer mold via thermocouples placed 7 mm from the plug edge.
- 4 The  $V_{BUS}$  to Gnd voltage will be observed to turn off and turn on.
- 5 Pass/fail evaluation: Pass =  $V_{BUS}$  voltage toggling off indicates setP has activated, protecting the cable from overheating.

| $V_{BUS}$ System Voltage (V) | Suggested Resistor Rating Range ( $\Omega$ ) |     |
|------------------------------|--|-----|
|                              | Min  | Max |
| 5                            | 3.3  | 8.2 |
| 9                            | 5  | 27  |
| 12                           | 6.5  | 48  |
| 15                           | 8.3  | 75  |
| 18                           | 10   | 108 |
| 20                           | 12   | 130 |

Table 2. Contamination test board resistor values

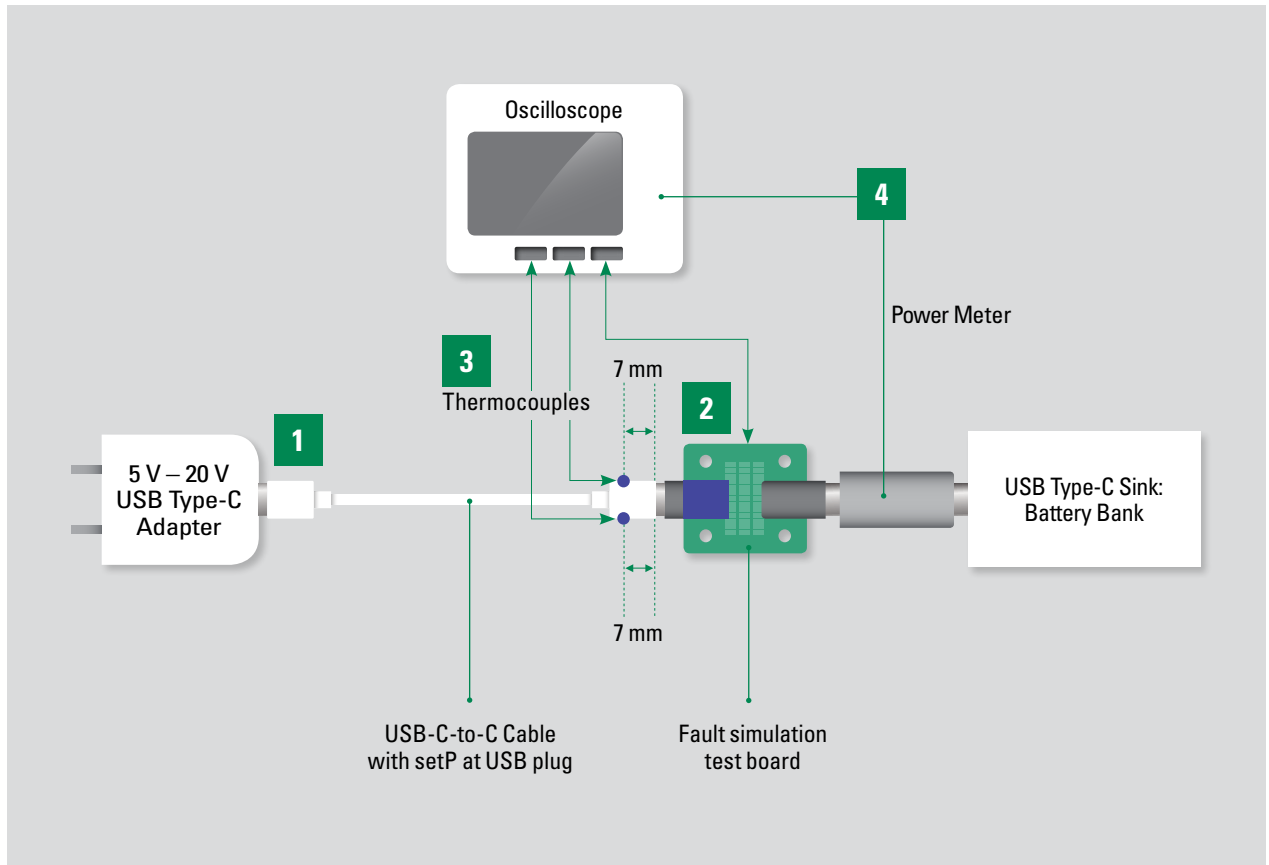

Figure 8. Design verification method 2 test setup

## 6.2 Testing Method: Quality Assurance

A simple measurement of the CC line's resistance is sufficient to ensure proper assembly of setP devices.

- 1 When writing the Quality Control Plan for the mass production of cables, identify multiple stages of assembly at which to perform the resistance measurement. Suggested stages at which to perform testing include:
  - Before inner-molding process, when all soldering processing is completed.
  - Before packaging process, when molding process is completed.
- 2 Determine the number of cables to be tested for each lot.
- 3 Connect the USB-C cable to an ohm-meter
- 4 Measure the resistance of the CC line from one end of the USB-C connector to the other end.
  - Refer to Figure 9 for cables with a USB-C plug on each end.
  - Refer to Figure 10 for cables with a USB-C plug on one end, and open or no connector on the other end. This is common for cables built as a sub-assembly for use in a captive-cable charger.
- 5 Pass/fail evaluation: Pass = resistance of setP is less than its  $R_{1max}$  value. Refer to the datasheet for  $R_{1max}$  for each part number.

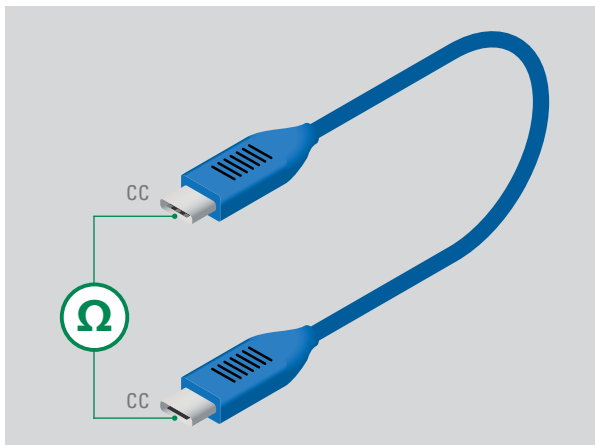

Figure 9. USB Type-C to Type-C cable quality assurance test

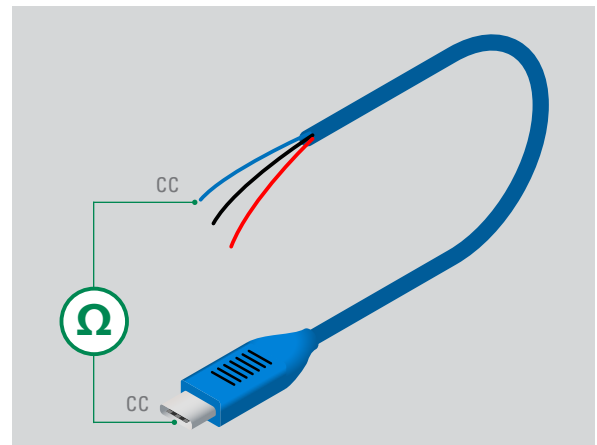
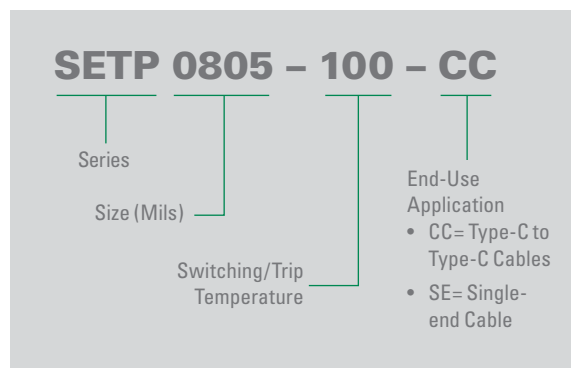

Figure 10. USB Type-C to open cable quality assurance test

## 7.0 Part Numbering and Selection Guidance



| Application                                   | Part Suggestion | Characteristic(s) most important to selection  |
|---|-----------------|--|
| USB Cables:<br>Type-C to Type-C               | SETPxxxx-xxx-CC | <ul style="list-style-type: none"> <li>• Two setP devices per cable</li> <li>• One setP device for each USB Type-C plug</li> </ul> |
| Chargers with captive USB Type-C output plugs | SETPxxxx-xxx-SE | One setP device per cable  |

## Appendix A: Power Negotiation Over CC Line of USB Type-C

According to USB-IF specifications, the maximum allowable DC resistance on the CC wire inside a cable is 15  $\Omega$ . This is defined in Table 3-23 of the USB Type-C Cable and Connector Specification, reproduced here as Table A1.

| Name                  | Description                                     | Min | Max  | Units    |
|-----------------------|---|-----|--|----------|
| zCable_CC             | Cable characteristic impedance on the CC wire   | 32  | 93   | $\Omega$ |
| rCable_CC             | Cable DC resistance on the CC wire              |     | 15   | $\Omega$ |
| tCableDelay_CC        | Cable propagation delay on the CC wire          |     | 26   | ns       |
| cCablePlug_CC         | Capacitance for each cable plug on the CC wire  |     | 25   | pF       |
| zCable_SBU            | Cable characteristic impedance on the SBU wires | 32  | 53   | $\Omega$ |
| tCableDelay_SBU       | Cable propagation delay on the SBU wires        |     | 26   | ns       |
| rCable_SBU            | DC resistance of the SBU wires in the cable     |     | 5  | $\Omega$ |
| SBU SE Insertion Loss | Cable SBU single-ended insertion loss           |     | 2.0 @ 0.5 MHz<br>4.0 @ 1 MHz<br>9.0 @ 10 MHz<br>10.7 @ 25 MHz<br>11.9 @ 50 MHz<br>13.0 @ 100 MHz | dB       |

**Table A1.** Electrical requirements for CC and SBU wires

The voltage value on the CC line is monitored by the sink. Based on the voltage value measured by the sink, the sink will understand the power capability of the source.

As described in Section 4.11.3 of the USB Type-C Cable and Connector Specification, the Source measures the CC voltage to detect whether the Sink is attached. When the CC voltage is equal to or greater than vOPEN, the Source assumes that there is nothing connected. See Appendix D for further information regarding how Source advertisement affects system trip performance.

Table A2 lists approximate CC voltage values at various ranges and power levels.

| CC Voltage Value Range (When Sink Connected) | Source Power Level              | Minimum CC Voltage for vOPEN |
|--|---------------------------------|------------------------------|
| 0.25 V to 1.6 V                              | Default USB Power (0.9 A @ 5 V) | 1.65 V                       |
| 0.45 V to 1.6 V                              | 1.5 A @ 5 V                     | 1.65 V                       |
| 0.85 V to 2.6 V                              | 3.0 A @ 5 V                     | 2.75 V                       |

**Table A2.** CC voltage vs. power level



To achieve these CC voltage values, multiple variables can be adjusted:

1. The Source provides a current Source as seen in Figure A1.
2. The Source provides a voltage Source with 5 V and a pull-up resistor ( $R_P$ ) as shown in Figure A2.
3. The Source provides a voltage Source with 3.3 V and a pull-up resistor ( $R_P$ ) as seen in Figure A2.

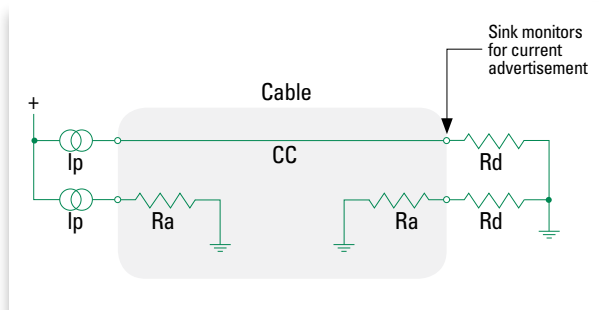

**Figure A1.** Sink monitoring for current in current source/pull-down CC model

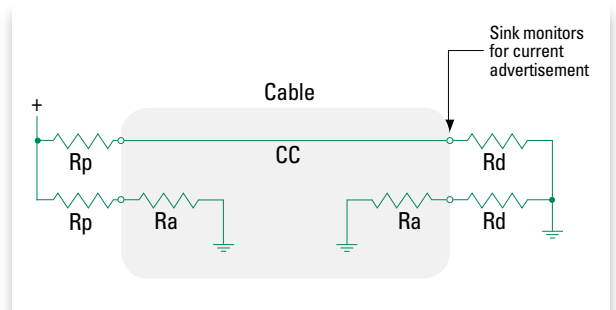

**Figure A2.** Sink monitoring for current in pull-up/pull-down CC model

The setP device has been designed to comply with the resistance values at both the normal operating temperature and the abnormal fault condition temperature.

The system enters into USB PD mode when both Source and Sink have a PD Controller that communicates over the CC line using a USB-IF defined protocol.

## Appendix B: Applicable Standards

### USB-IF Documentation:

- USB Type-C™ Cable and Connector Specification
- USB Power Delivery Specification

### Underwriters Laboratories:

- UL 9990 Outline of Investigation for Information and Communication Technology (ICT) Power Cables

## Appendix C: setP Protection Verification

Two conditions must be considered to verify any protection method. The first is that the protection used should not interfere with the intended operation of the system. The second is that the protection device ensures a fault is stopped prior to a predetermined amount of damage.

To confirm that the setP device does not interfere with the communication occurring on the CC line, the highest possible bit rate, 330 kbps<sup>ii</sup>, was used to create the eye diagram illustrated in Figure C1. The eye diagram was created using a USB Type-C cable with a setP device inside.

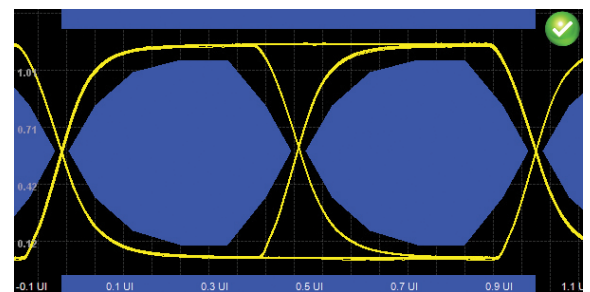

**Figure C1.** setP eye diagram

The results confirm that a setP device won't interfere with the communication intended for the CC line.

The next step is confirming whether a setP device has the sensitivity and speed necessary to prevent a cable from overheating. The test method described in Section 6.1. of this design guide, "Design verification test method 2" was used to confirm the surface temperature of the plug would be limited to 80° C or less as described by the requirements outlined in Table 6-14 of the USB Type-C Cable and Connector Specification.

<sup>ii</sup> **Source:** *USB Power Delivery (USB-PD) Specification, Table 5-17*

As shown in Figure C2, the surface temperature of the plug was measured to be less than 75°C. Because both temperature measurements were lower than 80° C, this confirms the setP device can prevent a heating fault from damaging the plug.

In contrast, a cable with no known protection was tested in the same way. This cable without a setP device inside was damaged and showed a very high surface temperature, as shown in Figure C2.

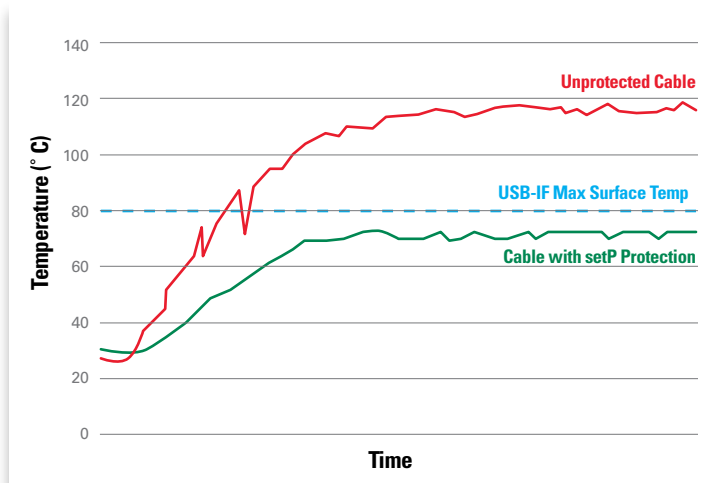

Figure C2. Surface temperatures during overheating test

## Appendix D: Source Advertisement vs. Trip Temperature

USB Sources can output a variety of power levels. Refer to Section 4.11—Parameter Values in the USB Type-C Cable and Connector Specification. The Source will advertise to the Sink its power level using a constant voltage Source or a constant current Source. Both methods result in an advertisement current of between 80  $\mu\text{A}$  and 330  $\mu\text{A}$ . When the advertisement current is 80  $\mu\text{A}$ , the setP device must reach 35  $\text{k}\Omega$  or higher to cause vOpen. When the advertisement current is 330  $\mu\text{A}$ , the setP device only needs to reach 4  $\text{k}\Omega$  or higher to cause vOpen.

In two systems with the same design (e.g., 3 A at 5 V) but using different advertisement (e.g., voltage or current Source), the trip temperature can be expected to vary by a few degrees. The resistance vs. temperature curve (Figure D1) illustrates this small variation.

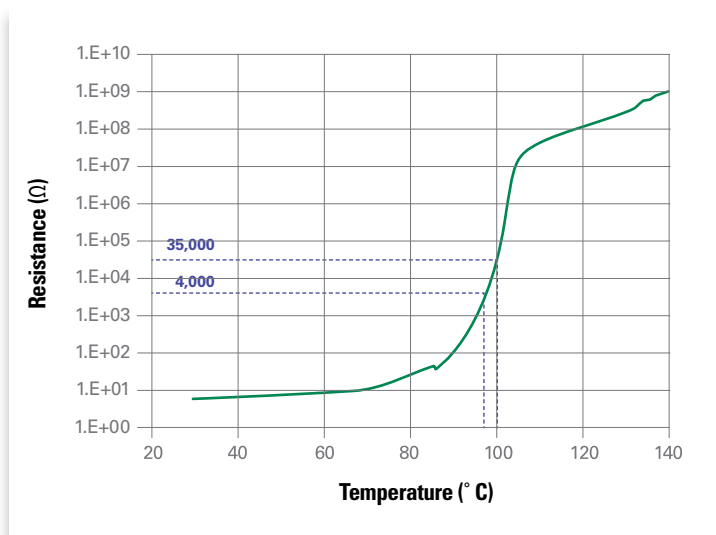
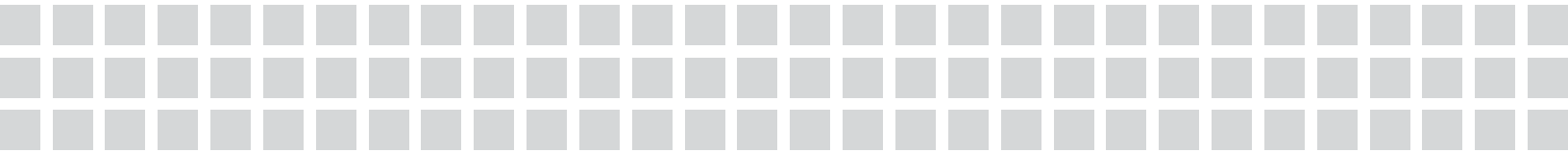

Figure D1. setP resistance vs. temperature curve

Figure D1 shows that if the advertisement current is 330  $\mu\text{A}$  for a 3 A and 5 V Source, the setP device will cause a trip at 4  $\text{k}\Omega$ , then the trip temperature will be about 97°C. If the advertisement current is 80  $\mu\text{A}$ , the setP device will cause a trip at 35  $\text{k}\Omega$ , then the trip temperature will be about 100°C.



Expertise Applied | Answers Delivered

[littelfuse.com](http://littelfuse.com)