

## Top 10 Circuit Protection Considerations

(Published February 2013, *Konstruktion & Entwicklung* magazine, Germany)

Selecting the right circuit protection components is essential to designing robust, reliable industrial power conversion equipment. This article, drawing on the experience Littelfuse has accumulated over 85 years, outlines the top 10 overvoltage (OV) and overcurrent (OC) protection considerations for low voltage (<1000V) light industrial applications.

### System Operating Voltage

For low voltage equipment, system voltage varies by application, from the 400VAC European three-phase supply to the 3.3VDC system control board.

For OV protection, it is generally accepted that the rating of the stand-off voltage device must be higher than the peak voltage for AC or the highest DC voltage of the power source, including any temporary or long-term testing conditions. Increasing the stand-off voltage reduces the number of low level conducting events the device must withstand, which will increase life expectancy but may also increase the peak let-through voltage or protection voltage, depending on the selected device.

For fuse and PPTC selection, the protection device's voltage rating must be higher than the system voltage including any temporary conditions.

### Interrupting Rating

In the circuit protection world, "interrupting" refers to the interrupting rating of a fuse or circuit breaker (or breaking capacity of a fuse).

The chart (right) is taken from a 1A TE type fuse, which is rated at 250VAC; the breaking capacity is at 25A, which means the fuse has the capability to open a 25A current safely at 250VAC.

A fuse's interrupting rating must be higher than

Amp Code	Rated Current	Voltage Rating	Breaking Capacity
0800	800 mA	250V	25A/250 VAC
1100	1.00 A	250V	25A/250 VAC
1125	1.25 A	250V	25A/250 VAC
1160	1.60 A	250V	25A/250 VAC

the available current from the circuit to be protected (often called the prospective short-circuit current).

### International Standards and Expected Withstand

To counter threats like ESD, EFT, and lightning induced surges, some important industry standards have been developed:

- ESD threat: IEC 61000-4-2
- Electrical fast transient: IEC 61000-4-4
- Lightning: IEC 61000-4-5

For ESD, the expected withstand is at least 8kV contact. For EFT, the expected withstand is between 1kV and 2kV (industrial). For lightning, the most common expected withstand levels are 6kV and 3kA.

### Endurance Requirements

Compact power conversion equipment components must endure high temperatures and thermal cycling reliably. For low voltage, low power interconnections, the requirement to survive ESD, EFT, or TLP may be up to 20 or 30kV contact discharge for ESD, level 5 or greater for EFT, and 10A+ of TLP.

Littelfuse has extended its line of industrial-grade parts in the AK Series Diodes up to 15kA 8/20us surge withstanding capability and developed the award-winning TMOV25S and TMOV34S devices to help power supply designs pass the relevant regulatory testing.

### Component Rating vs. Calculated Needs

The following illustration of a basic SMPS power structure shows where protection devices like fuses and MOVs/TVS Diodes are used.

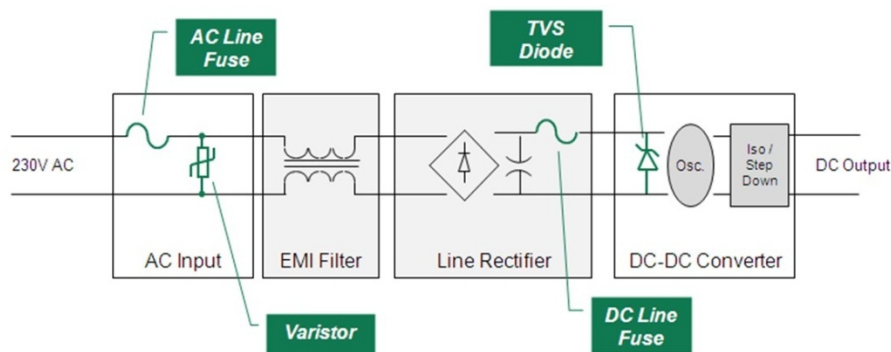

- 1) For surge testing, the fuse must not open due to the OV surge. The rule of thumb: the  $I^2t$  (Melting Integral) of the fuse should be at least five times that of the surge.
- 2) For OC testing, the fuse should open before other components are affected, start smoking or catch fire.
- 3) Fuse breaking capacity should be chosen based on short-circuit current capability of the power source including any cable/cord. IEC defines three levels (Low, Enhanced and High).
- 4) Post rectification part (DC Side): Littelfuse has specialty fuses designed for high voltage DC applications using 400VDC to 1000VDC.

### Lifetime Expectations

Designing an industrial power conversion product to last 10-20 years requires considering protection component degradation. For example, lightning induced surges have a quantifiable effect on MOV life. Much the same is true for fuses: in-rush current during a switch-on sequence can produce OC conditions.

MOVs exhibit a power withstanding curve. This graph indicates the number of pulse events a particular MOV can withstand for the pulse duration. This should be considered in conjunction with the electrical environment in which the equipment will be installed.

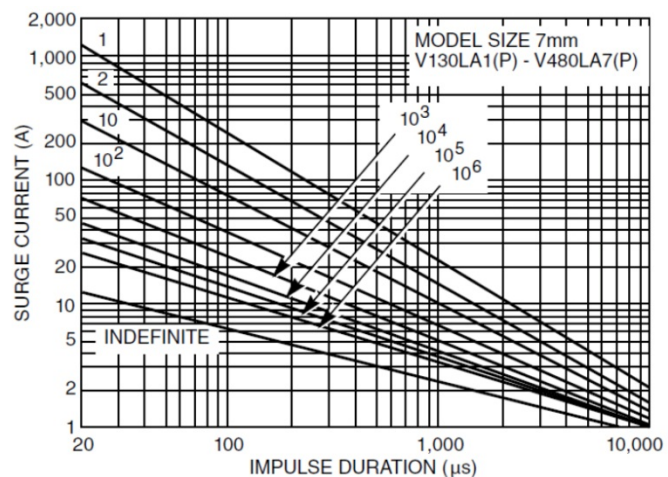

Temperature derating for OC protection/fuses from 25°C to 85°C:

- For a WIA (Wire-In-Air) fuse, derate about 5%.
- Thin film fuse, derate at 10%.
- Resettable PPTC, derate at 40%.

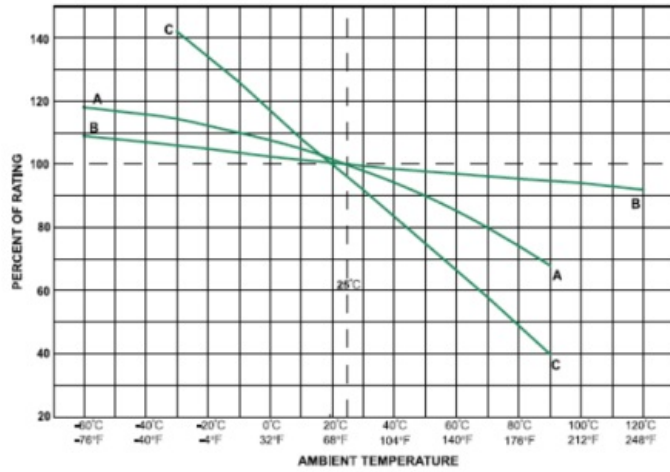

Pulse cycle withstand for WIA fuses.

Stressing a fuse with impulse OC conditions affects the wire element and increased pulse magnitude reduces life.

**CHART II**

**PULSE CYCLE WITHSTAND CAPABILITY**

100,000 Pulses	Pulse I <sup>2</sup> t = 22% of Nominal Melting I <sup>2</sup> t
10,000 Pulses	Pulse I <sup>2</sup> t = 29% of Nominal Melting I <sup>2</sup> t
1,000 Pulses	Pulse I <sup>2</sup> t = 38% of Nominal Melting I <sup>2</sup> t
100 Pulses	Pulse I <sup>2</sup> t = 48% of Nominal Melting I <sup>2</sup> t

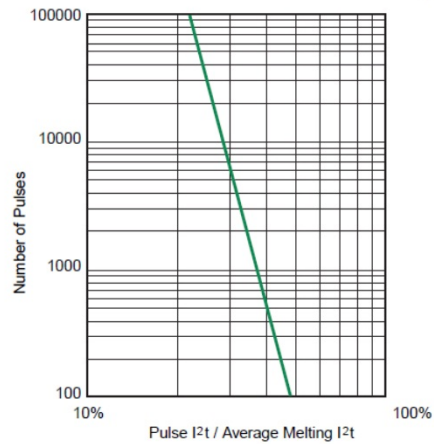

Note: Adequate time (10 seconds) must exist between pulse events to allow heat from the previous event to dissipate.

## Voltage Limiting Requirements

Control ICs used for industrial power conversion control are smaller, faster and less tolerant of OV and OC, so shorter reaction times and lower protection voltages are essential, especially if the IC has a direct connection to other equipment. Intelligent power control often consists of analog lines, RS communication and/or differential bus communication. Littelfuse has a family of SPA (Silicon Protection Arrays = Diode Arrays) devices tailored for these applications.

The two most common ways of diverting OV events to protect sensitive control ICs are **crowbar** and **clamping** devices. The crowbar method can be used for wiring of a data port depending upon prevailing operating conditions. The clamping method can be used for both AC and DC power lines, as well as datalines and analog lines.

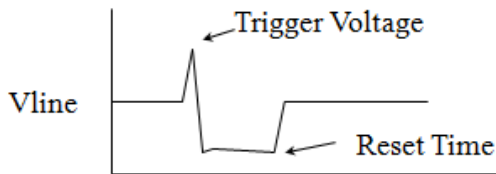

**Crowbar Devices**  
(GDT, SIDACTor, and PGB)

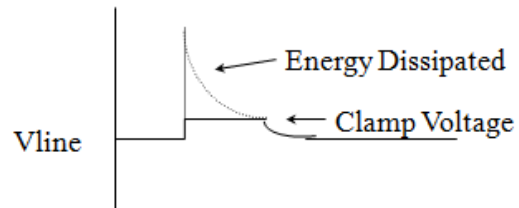

**Clamping Devices**  
(TVS, MOV, and MLV)

## Long-Term and Temporary OV

For mains power, select an OV protection device with a rated operating voltage above any potential high mains or long-term OV condition to ensure the device is not rendered ineffective by over-dissipation. Safety agencies sometimes impose Temporary OV (TOV) testing conditions on equipment; any OV protection device must be able to survive these temporary conditions without risk of fire, etc. TOV conditions can cause catastrophic failure of OV protection devices like varistors due to the longer duration of fault current going through the device. Littelfuse TMOV<sup>®</sup> Series Varistors have an integrated thermal cut-out device coupled to the varistor disc for optimal protection against dangerous TOV conditions.

## Component Effects on Data

Parallel data transmission is giving way to serial data transmission as control ICs become faster and smaller, and data rates have risen sharply. Most of the ICs used now have finer internal geometries, leading to a reduction in OV withstand.

Littelfuse was the first supplier to introduce **eye diagram measurements** for signal integrity checks of ESD protection devices such as PulseGuard® for USB 2.0 ESD protection.

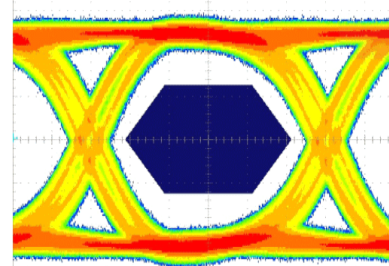

As a rule of thumb, the 480Mbps data rate of USB 2.0 requires that the capacitance of the protection device be lower than 3.0pF in order to avoid signal integrity problems. The highest capacitance Littelfuse PulseGuard product is 0.12pF; with a leakage current of less than 1nA, it does not disturb such communications.

The following table compares the most common ESD protection technologies Littelfuse offers for their suitability for various data rates/interface speeds.

Protection Technology	Data Rate	Peak/clamp (8kV)	ESD Level	Discrete Options	Array Options	Applications and Circuits	Relative Cost	Key Advantage
<a href="#">MLV</a>	<125 Mbps	Good	Good	0201 0402 0603 0805 1206	1206	<a href="#">Keypad/switch, audio, analog video, USB1.1, RS232</a>	Best	Lowest cost; broad discrete offering
<a href="#">SPA</a>	≤5Gbps	Excellent	Excellent	0402 (SOD723) 0201 (Flipchip)	SOIC MSOP SOT23 SC70 SOT553 SOT563 SOT953 µDFN	<a href="#">Keypad/switch, USB1.1, USB2.0, USB3.0, Audio, Analog video, 1394, HDMI, Ethernet, MMC interface, LCD module</a>	Good	Lowest peak and clamping voltages
<a href="#">PGB</a>	10Gbps+	Fair	Good	0402 0603	SOT23	<a href="#">USB2.0, 1394, HDMI, RF antenna</a>	Good	Lowest capacitance

## Protection and Testing

Today, less circuit design time is available than ever, which can compromise circuit protection. Littelfuse has test labs around the globe to help customers test and debug their boards and applications before applying for official certification.

With on-site expert guidance, world-class test equipment, and circuit protection solution support, Littelfuse truly stands for expertise applied, answers delivered.

