

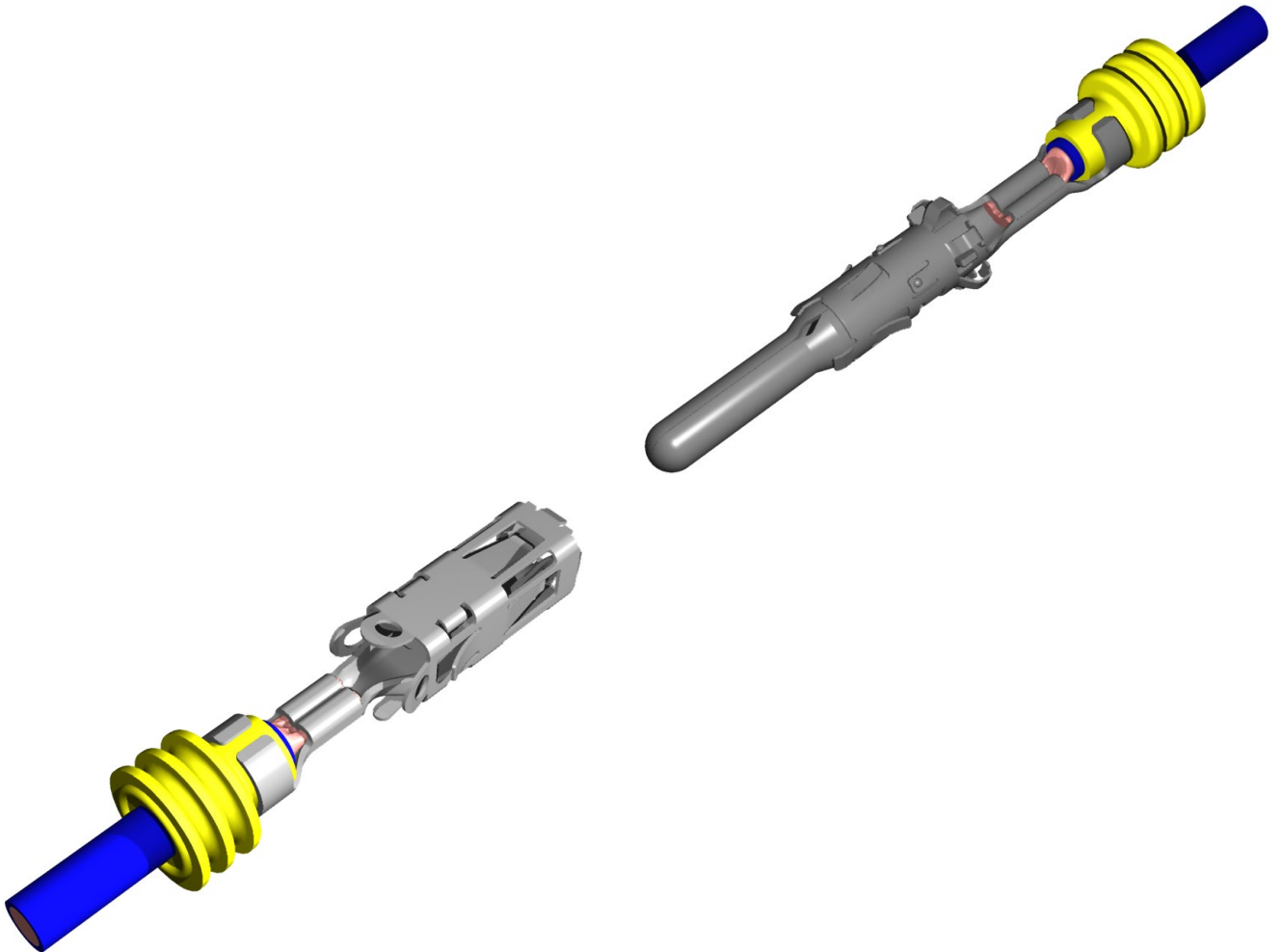

Terminals & Connectors



Product specification

VKR Plus - VKS Plus



Index

1. Product
2. Drawings
3. Extraction tool
4. Product description
5. Application reports
6. Technical specification
7. Environmental simulation
8. Chemical resistance
9. Documentation summary
10. Benefits

1. Product - VKR plus

Part number - VKR plus:

26570 / for CSA: 0.50 – 1.0 sqmm

26571 / for CSA: 1.50 – 2.5 sqmm

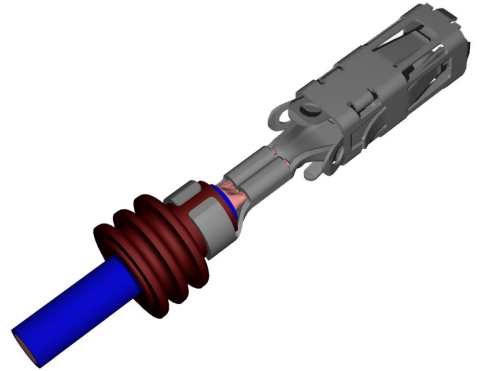

Single cable seal:

14414 (brown) / for CSA: 0.50 – 1.0 sqmm

14415 (grey) / for CSA: 1.50 – 2.5 sqmm

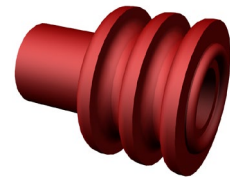

cavity plug

16315.627.646 (green)

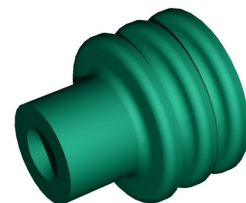

1. Product - VKS plus

Part number - VKS plus:

26634 / for CSA : 0.50 – 1.0 sqmm

26633 / for CSA : 1.50 – 2.5 sqmm

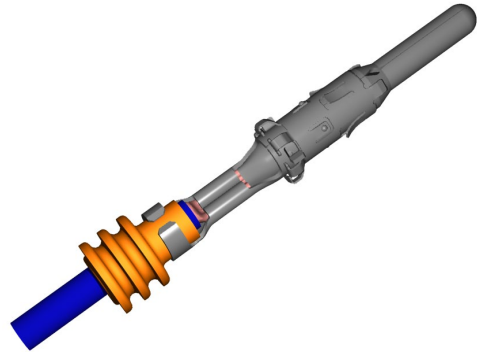

Single cable seal:

14740 (white) / for CSA : 0.50 – 1.0 sqmm

14739 (orange) / for CSA : 1.50 – 2.5 sqmm

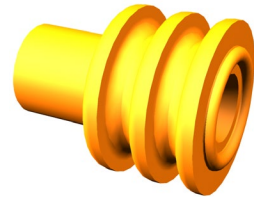

cavity plug

14741.627.610 (yellow)

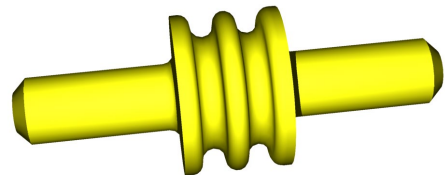

1. Product - Housings

Cabin inter-connect housings

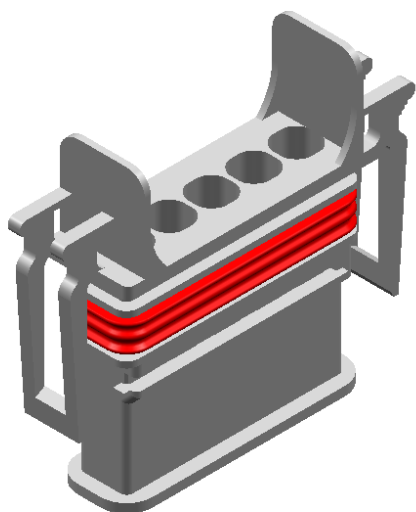

5-way unsealed

10-way unsealed

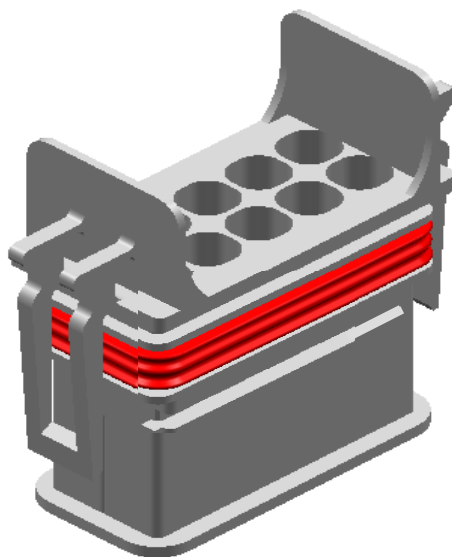

1. Product - Housings

4-way sealed VKR housing

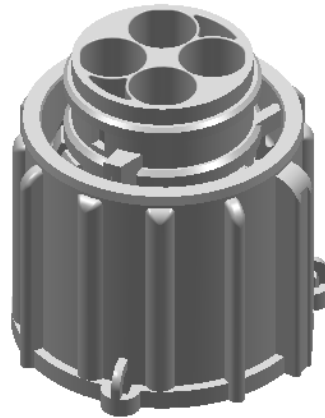

4-way sealed VKS housings

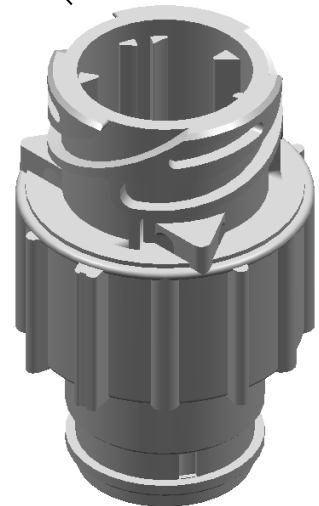
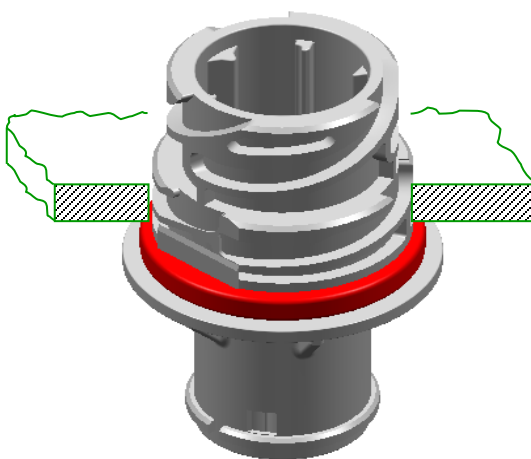

1. Product

VKR/ VKS Plus Ø 2.5 mm

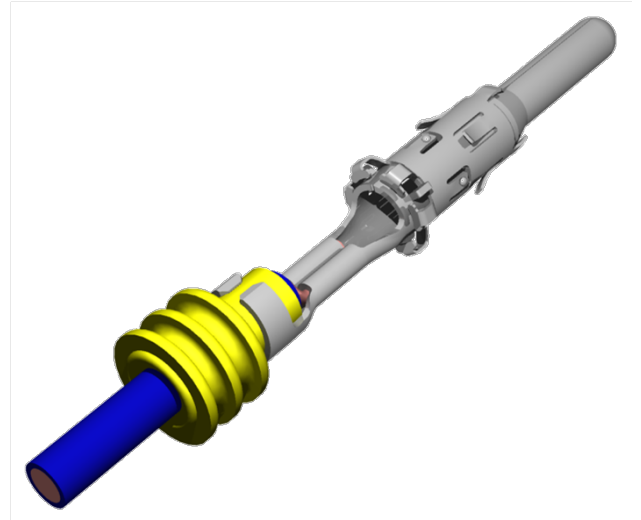
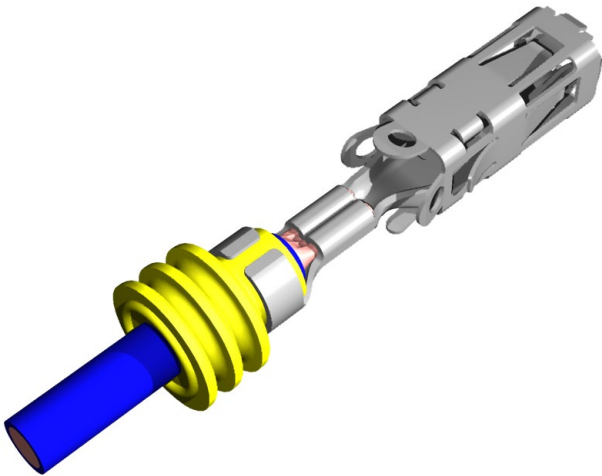

Contact principle

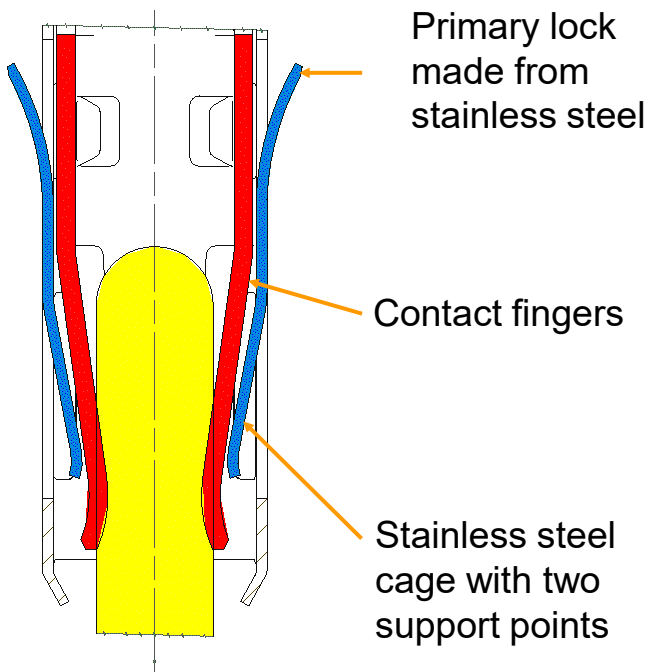

Primary lock
made from
stainless steel

Contact fingers

Stainless steel
cage with two
support points

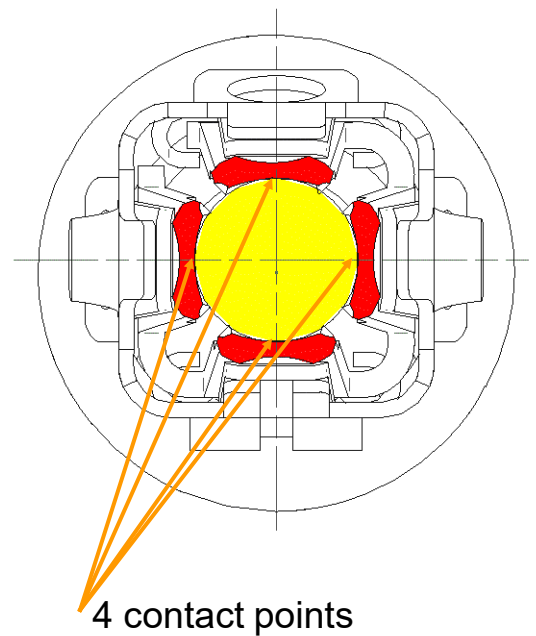

4 contact points

2. Drawing cable seals

4	14415	627	670	grau	1,0...2,5	0,5...1,5	1,9...3,0	6.7 ±0.05	1.3	2.35	4.25	5.0	5.25	7.25	7.5	3.5	1.2	1.65	0.3	3.6	1.65	0.7	0.4	0.4
	14414	627	626	rotbraun	0,35...1,00	0,22...0,38	1,2...2,1		0.85	1.65														
Typ Nr.	Teil-Nr.	Stoff	Ofi.	Farbe	FLR	FL	Ø	ØGehäusebohrung	Abmessungen															
	Bestell-Nr.				Querschnitt		Leitung																	

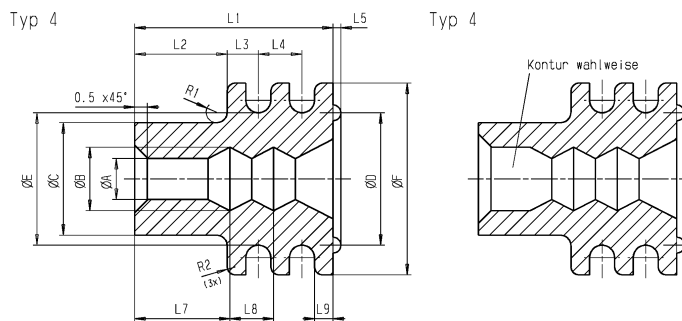

6	14739	627	619	orange	1,0...2,5	0,5...1,5	1,9...3,0	5.4 ±0.1	1.55	2.4	3.4	3.7	4.2	6.0	7.5	3.5	1.2	1.65	0.3	3.6	1.65	0.7	0.4	0.4
	14740	627	694	weiß	0,35...1,00	0,22...0,38	1,2...2,1		0.85	1.6														
Typ Nr.	Teil-Nr.	Stoff	Ofi.	Farbe	FLR	FL	Ø	ØGehäusebohrung	Abmessungen															
	Bestell-Nr.				Querschnitt		Leitung																	

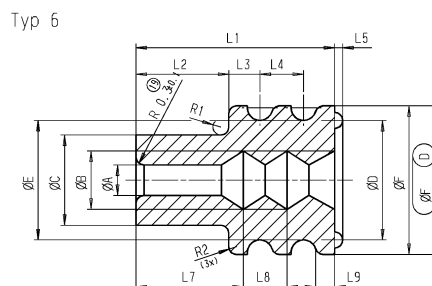

2. Drawing cavity plugs

4	16315	627	646	grün	$\varnothing 6.7 \pm 0.05$	-	$\varnothing 5.0$	-	-	-	$\varnothing 7.3$	13.3	7.3	0.7	1.65	1.3	-	-	-	0.5	...
Typ Nr.	Teil-Nr. Bestell-Nr.	Stoff	Ofl.	Farbe	Gehäuse- bohrung	Abmessungen															
					A ± 0.1	B ± 0.2	C ± 0.2	D ± 0.15	E ± 0.15	F ± 0.1	L1 ± 0.4	L2 ± 0.2	L3 $\begin{smallmatrix} +0.15 \\ -0.1 \end{smallmatrix}$	L4 ± 0.1	L5 ± 0.1	L6 ± 0.2	L7 ± 0.2	L9 ± 0.1	R1 ± 0.1	R2 ± 0.15	

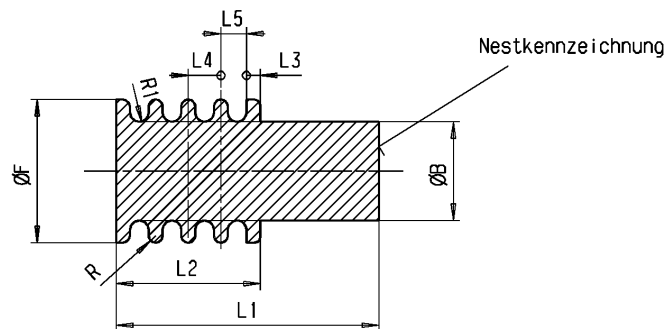

6	14741	627	610	gelb	$\varnothing 5.4 \pm 0.1$	-	-	$\varnothing 2.5$	-	$\varnothing 4.2$	$\varnothing 6.0$	16	4.0	0.7	-	-	-	-	-	0.4	0.4
Typ Nr.	Teil-Nr. Bestell-Nr.	Stoff	Ofl.	Farbe	Gehäuse- bohrung	Abmessungen															
					A ± 0.1	B ± 0.2	C ± 0.2	D ± 0.3	E $\begin{smallmatrix} +0.1 \\ -0.2 \end{smallmatrix}$	F ± 0.1	L1 ± 0.2	L2 ± 0.2	L3 ± 0.1	L4 ± 0.15	L5 ± 0.1	L6 ± 0.2	L7 ± 0.2	L9 ± 0.15	R1 ± 0.1	R2 ± 0.15	

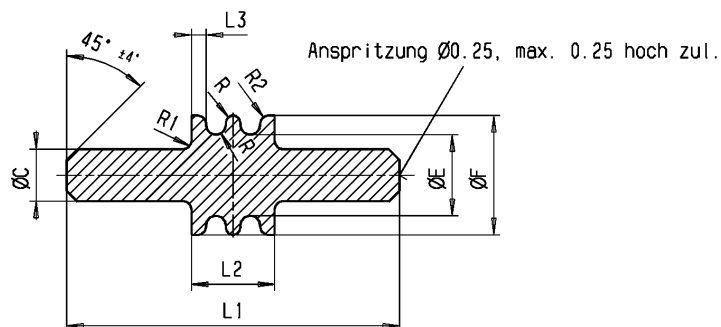

3. Extraction tool VKR Plus

VKR Plus

Part number: 50000.017.590



3. Extraction tool VKS Plus

VKS Plus

Part number: 50000.017.600



Spare part case VKS Plus

Part number: 50000.038.567

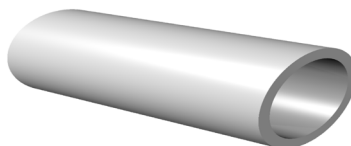

4. Product description

The VKR Plus is a 2.5 mm spring supported socket. It has a box-section and is designed for crimping with single cable seals.

The VKS Plus is a 2.5 mm spring supported pin for connecting to the VKR Plus socket. It has a box-section and is designed for crimping with single cable seals.

Operational usages:

High vibration systems in accordance with the requirements of

DIN 72585

Suitable for high vibration usage on chassis', engines, axles and gearboxes

4. Product description

Terminal materials

- Material

- Base material CuSn

- Spring X12 CrNi 17 7

- Plating

- Sn Thickness 2 to 4 μm

- Ag Thickness minimum 2 μm

- Au Selective plating

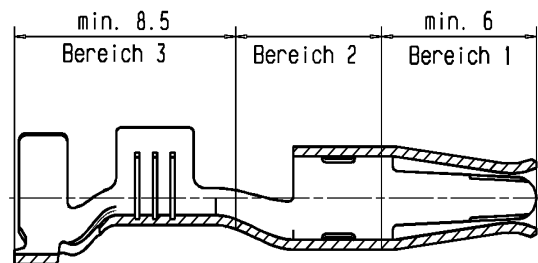

Bereich 1: inner gal Ni 2 + gal AU 1.5 , outer gal Ni 1

Bereich 2: both sides gal Ni 1

Bereich 3: both sides gal Ni 1 + gal Sn 1.5

Bereich 1: innen gal Ni 2 + gal AU 1.5, außen gal Ni 1

Bereich 2: beidseitig gal Ni 1

Bereich 3: beidseitig gal Ni 1 + gal Sn 1.5

4. Product description

Pitch size with seal: 7.0 x 7.0 mm

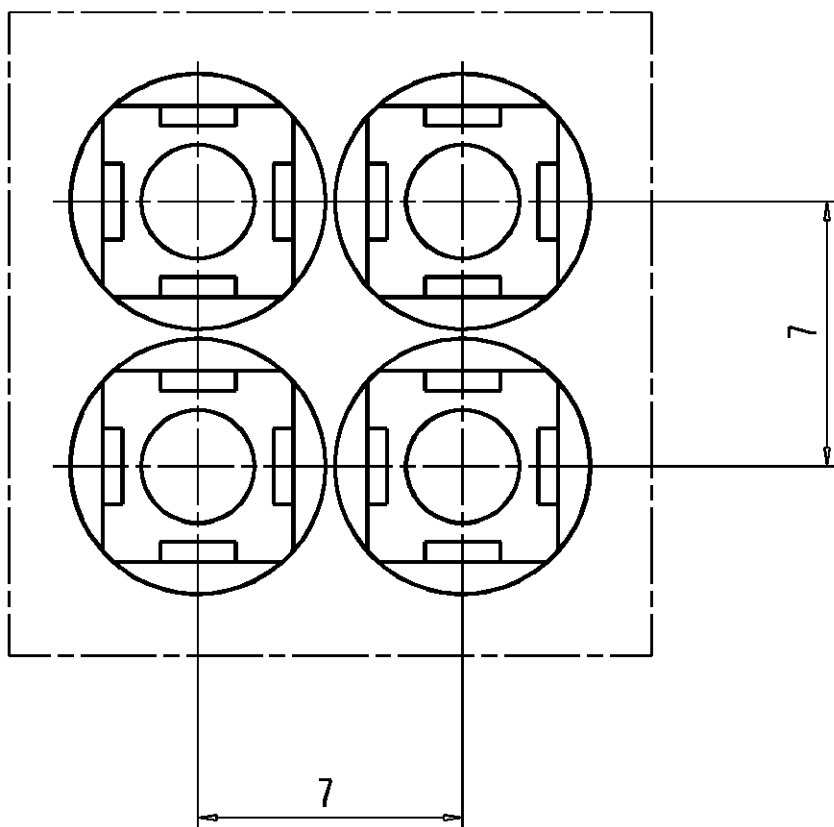

5. Application reports

The available specifications cover the following points:

- Implementation style
- Performance characteristics
- Testing

6. Technical Specification

- 6. 1 Current carrying
- 6. 2 Contact resistance
- 6. 3 Continuous temperature requirements
- 6. 4 Insulation resistance
- 6. 5 Terminal retention force in a housing
- 6. 6 Maximum pin angle
- 6. 7 Terminal cross-section
- 6. 8 Engagement and withdrawal forces
- 6. 9 Spring support force
- 6.10 Crimp measurements
- 6.11 Crimp tensile strength
- 6.12 Vibration requirements
- 6.13 Contact disconnection
- 6.14 Climate test
- 6.15 Water sealing
- 6.16 Thermal testing
- 6.17 Dynamic testing

6.1 Current carrying

Derating without housing

VKR - VKS Plus 0.50 / 0.75 / 1.00 mm²

Material: CuSn

Plating: Sn

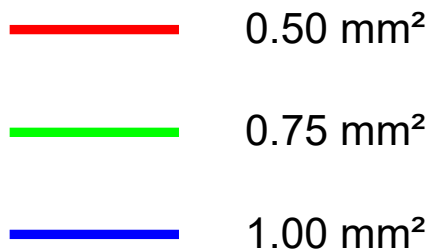
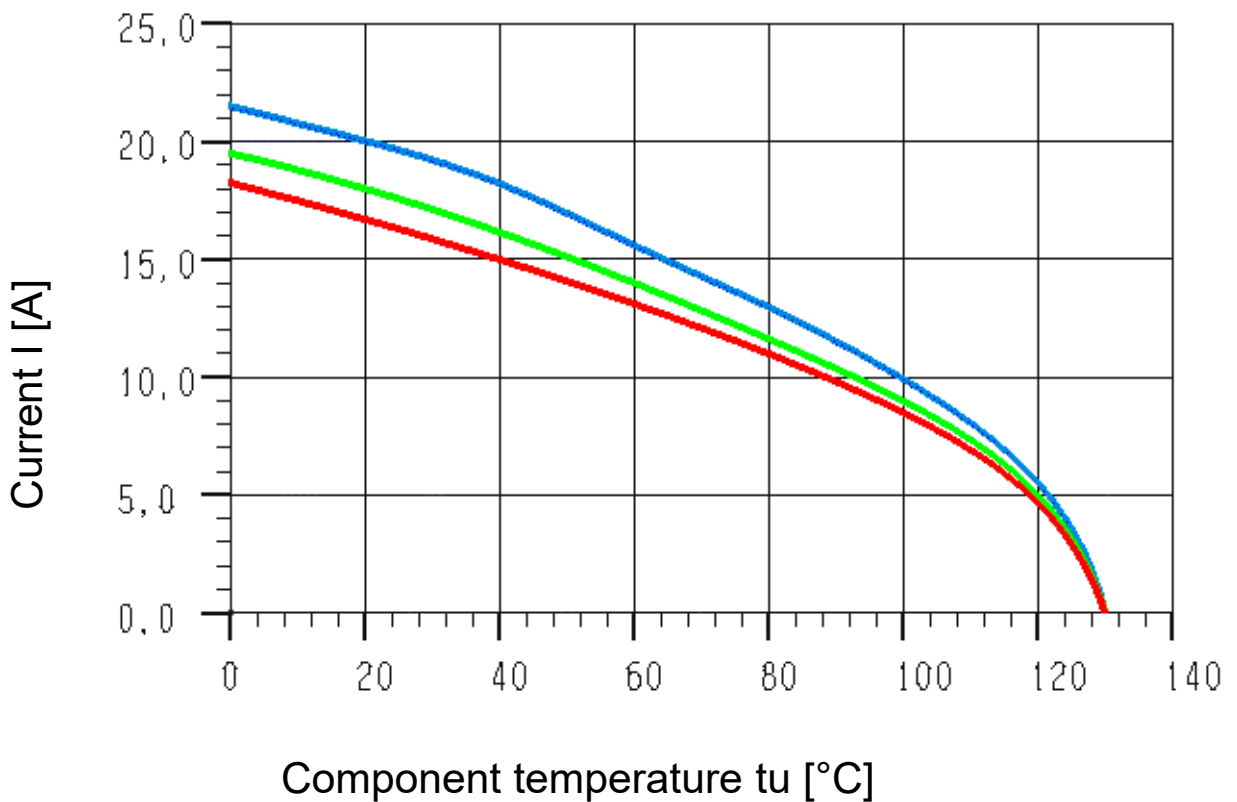

6.1 Current carrying

Derating without housing

VKR - VKS Plus 1.50 / 2.50 mm²

Material: CuSn

Plating: Sn

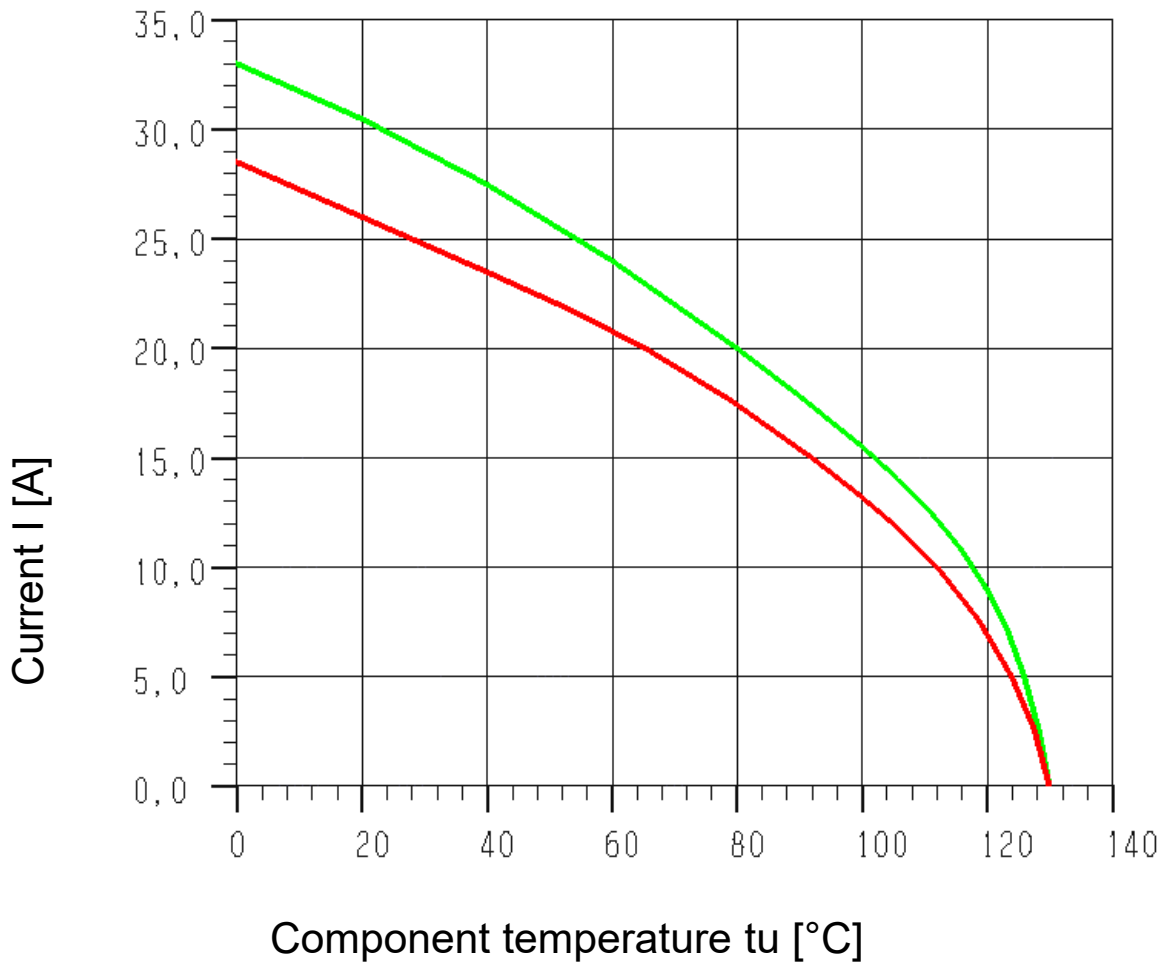

— 1.50 mm²

— 2.50 mm²

6.1 Current carrying

Derating in housing

VKR - VKS Plus 0.50 mm²

Material: CuSn

Plating: Sn

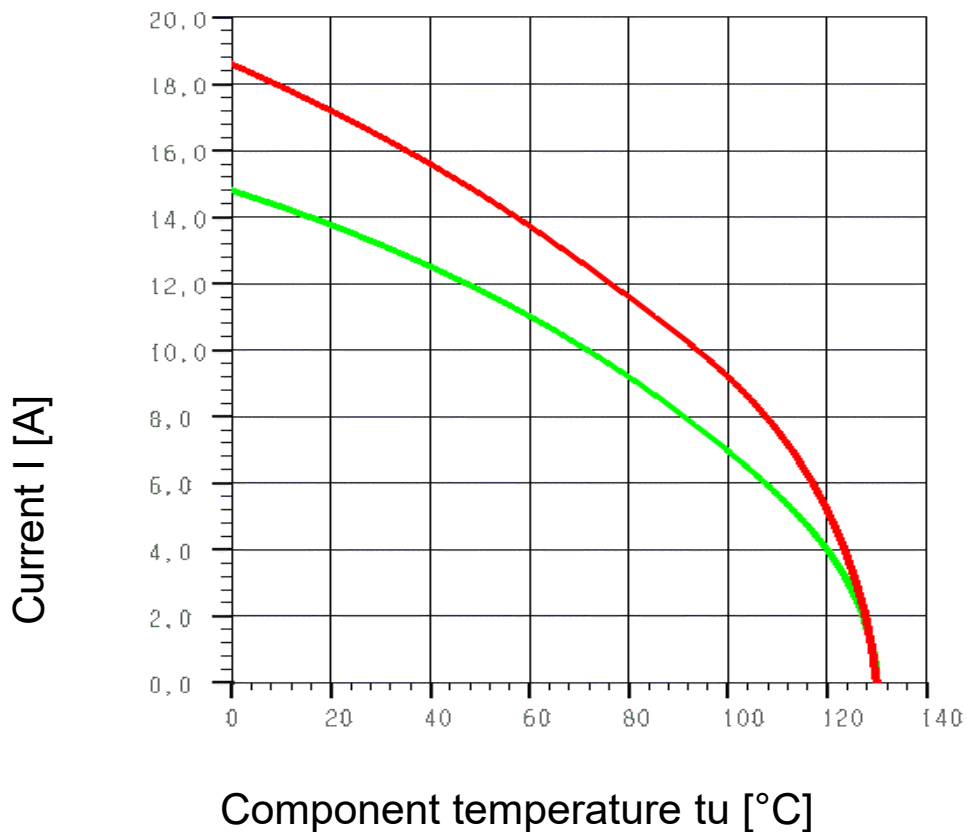

— 1-way

— 4-way

6.1 Current carrying

Derating in housing

VKR - VKS Plus 0.75 mm²

Material: CuSn

Plating: Sn

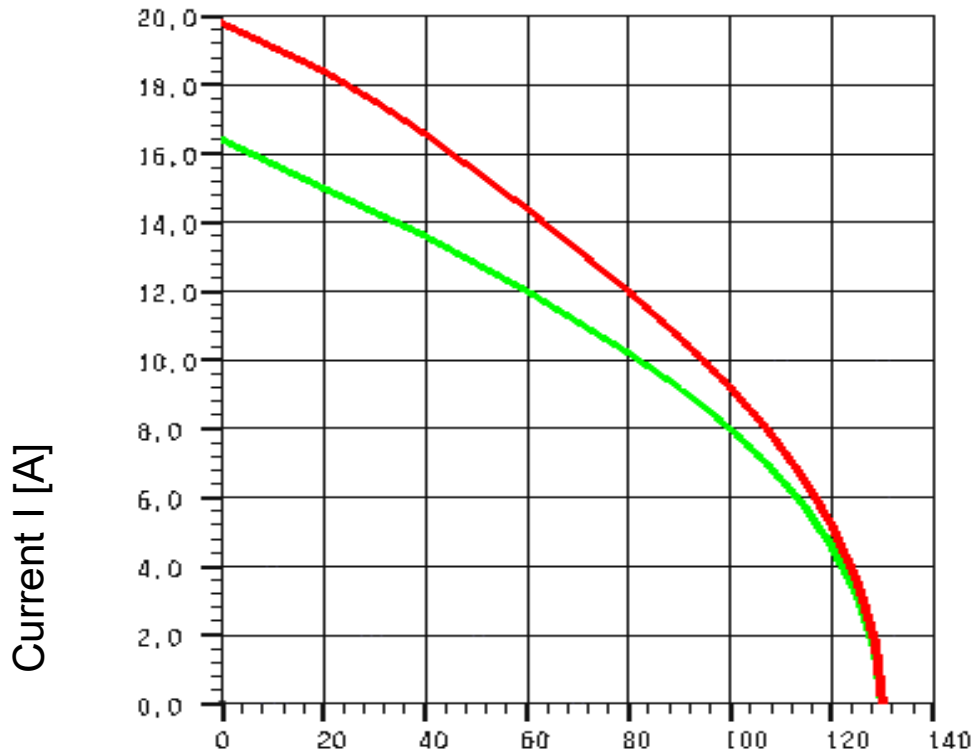

Component temperature tu [°C]

— 1-way

— 4-way

6.1 Current carrying

Derating in housing

VKR - VKS Plus 1.00 mm²

Material: CuSn

Plating: Sn

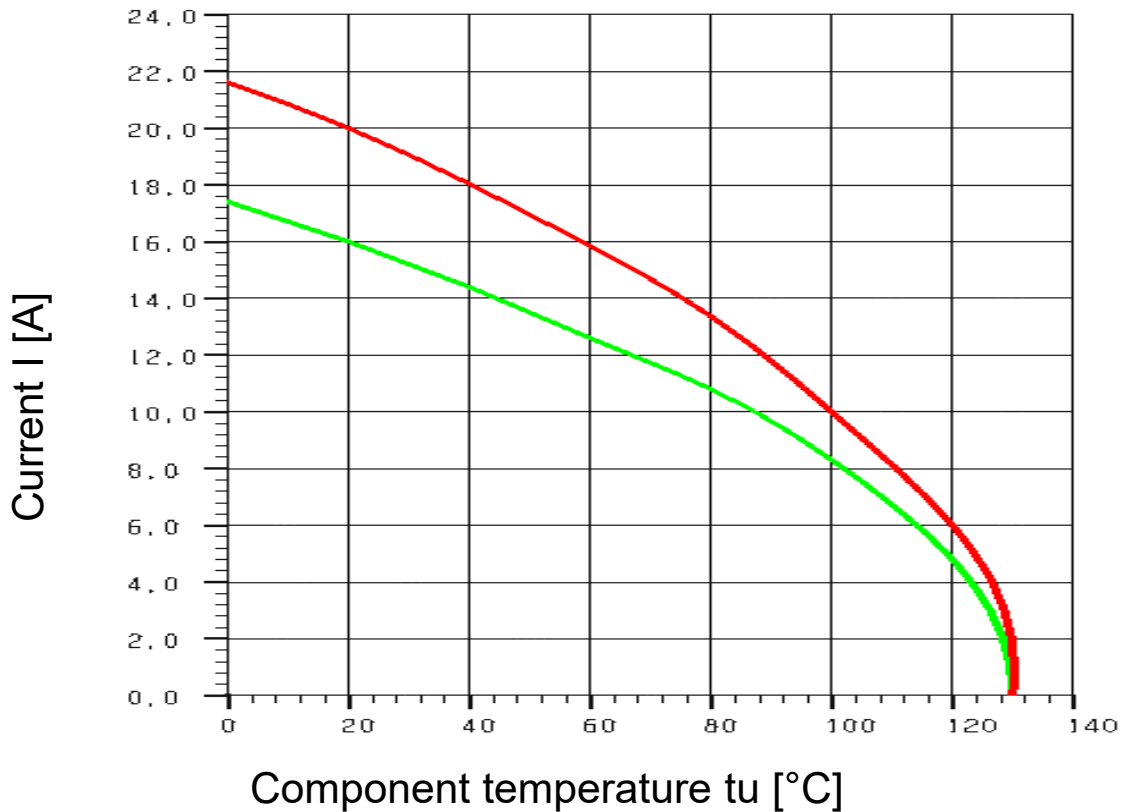

— 1-way

— 4-way

6.1 Current carrying

Derating in housing

VKR - VKS Plus 1.50 mm²

Material: CuSn

Plating: Sn

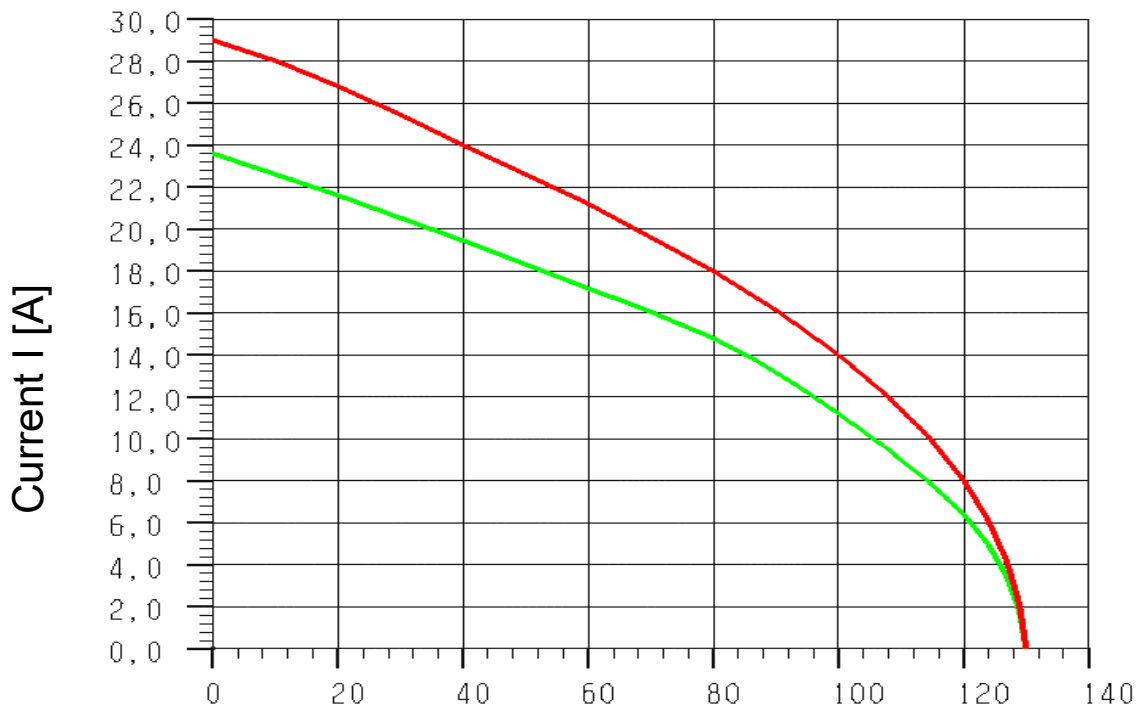

Component temperature tu [°C]

— 1-way

— 4-way

6.1 Current carrying

Derating in housing

VKR - VKS Plus 2.50 mm²

Material: CuSn

Plating: Sn

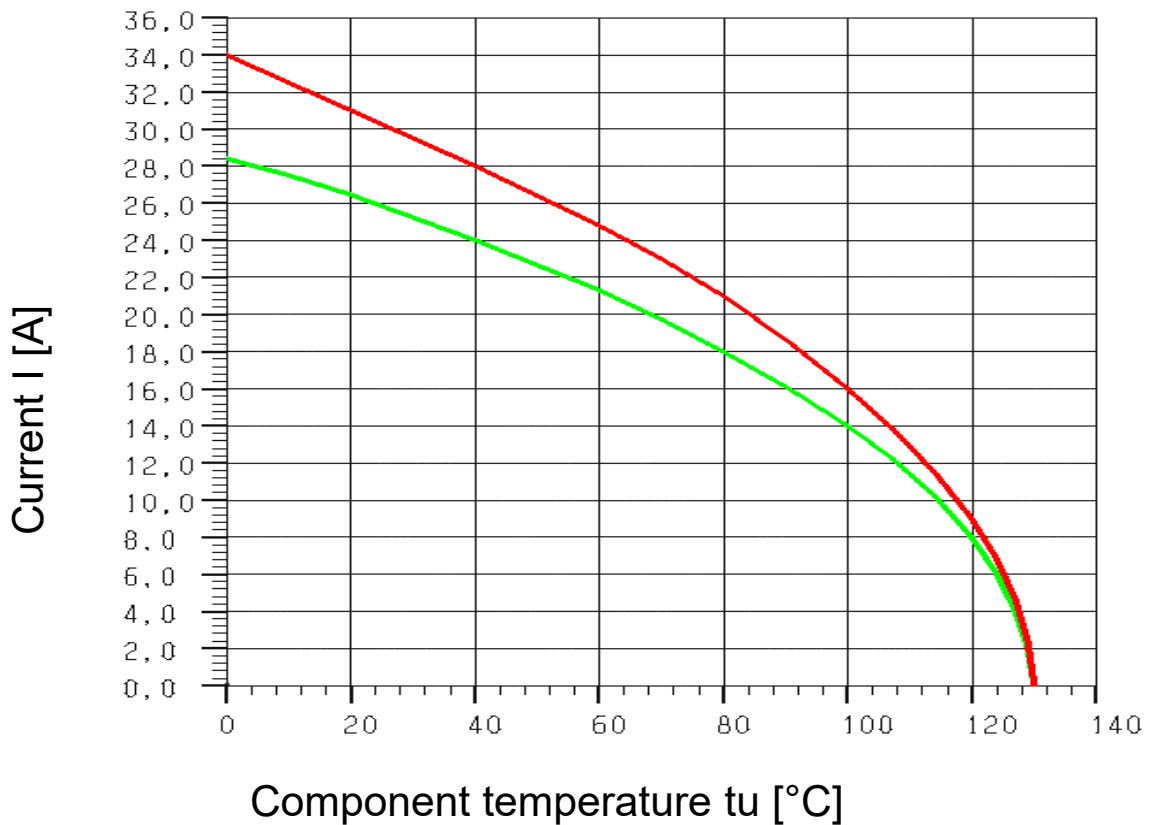

— 1-way

— 4-way

6.2 Contact resistance

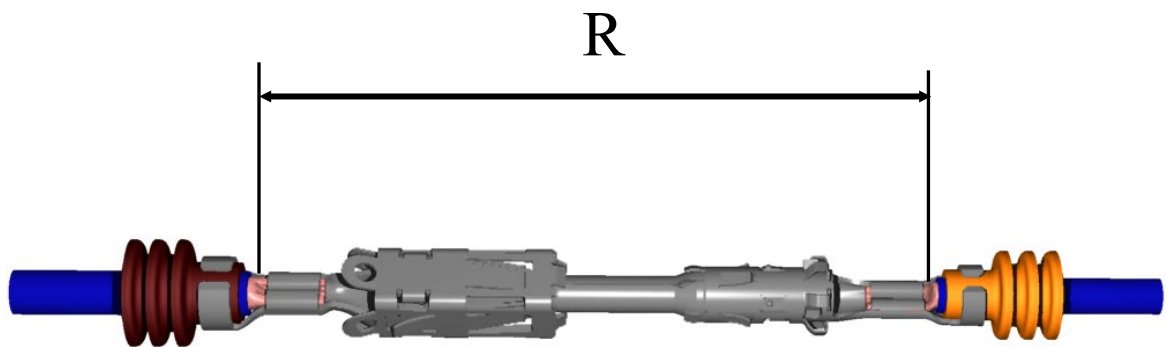

A value of 5 m Ω must not be exceeded for a new connection.

After testing to DIN 72585, a value of 10 m Ω must not be exceeded

6.3 Continuous temperature requirements

Plating Sn

The maximum continuous operating temperature for this terminal plating is + 130 ° C.

Connection cycles: maximum 20

Plating Ag

The maximum continuous operating temperature for this terminal plating is + 150 ° C, which is limited by the terminal material.

Connection cycles: maximum 50

Plating Au

The maximum continuous operating temperature for this terminal plating is + 150 ° C, which is limited by the terminal material.

Connection cycles: maximum 100

6.4 Insulation resistance

High voltage test

A test voltage of $U_{\text{eff}}=1000\text{ V}$, 50 or 60 Hz was applied over a minimum period of one minute across a set of terminals as well as between every other terminal and the outside of the housing with no shorting or carbonisation appearing.

The measured insulation resistance was greater than $10^7\Omega$

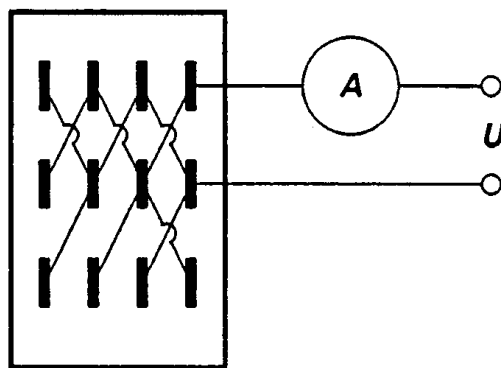

Measurement of the leakage current between adjacent terminals

6.5 Terminal retention force

Primary

- Terminal primary lock without housing secondary lock
- Material PA , PBT without glass filling

• > 60 N

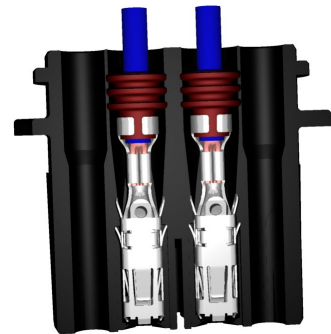

Secondary

- Housing secondary lock without terminal primary lock
- Material PA , PBT without glass filling

• > 80 N

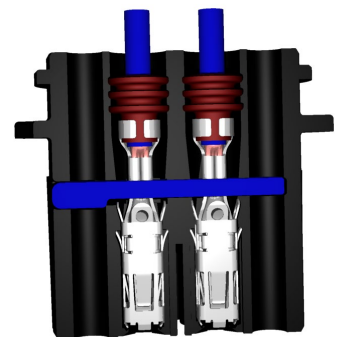
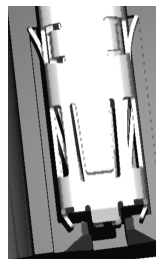
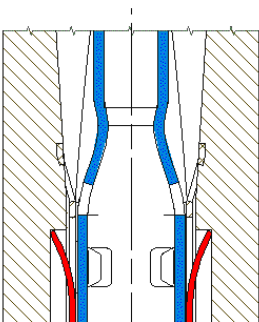

6.6 Maximum pin angle

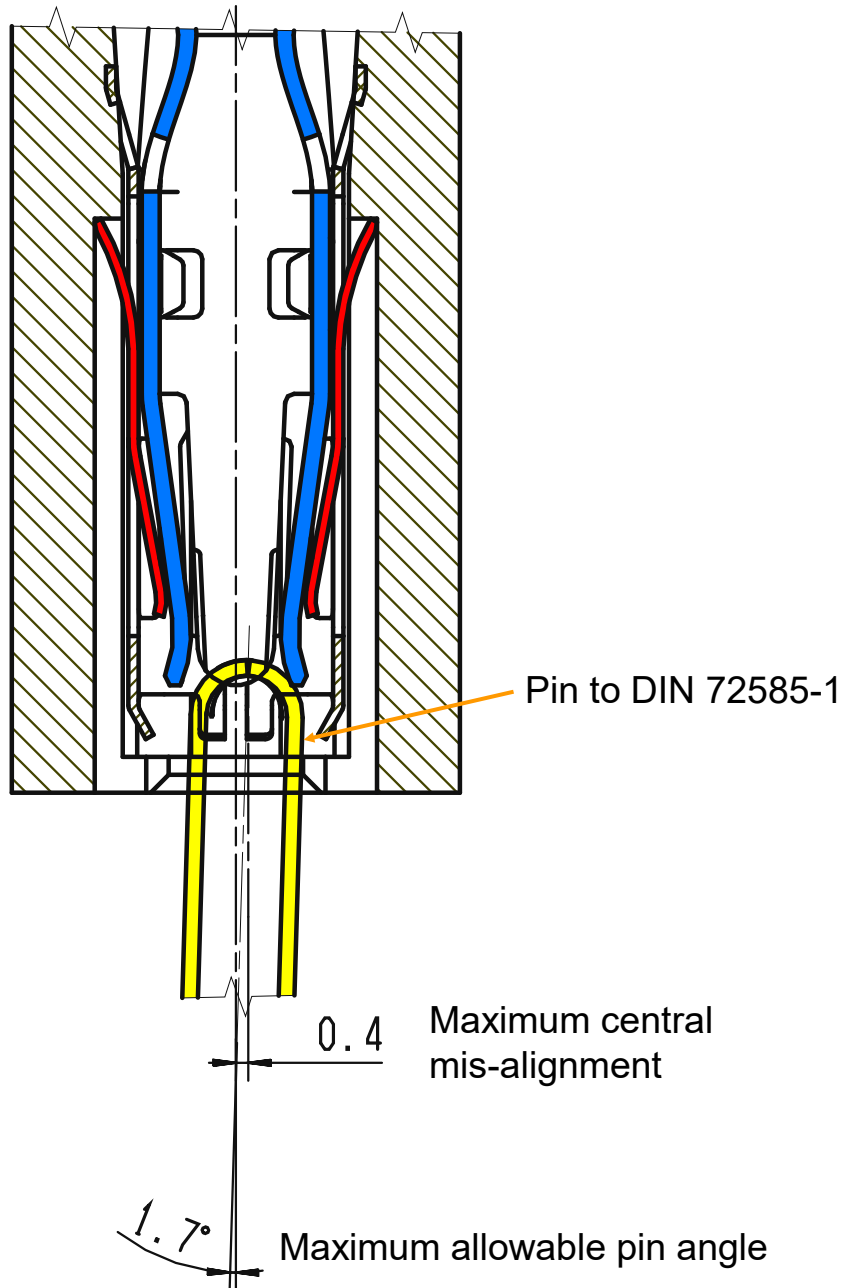

6.7 Terminal cross-section

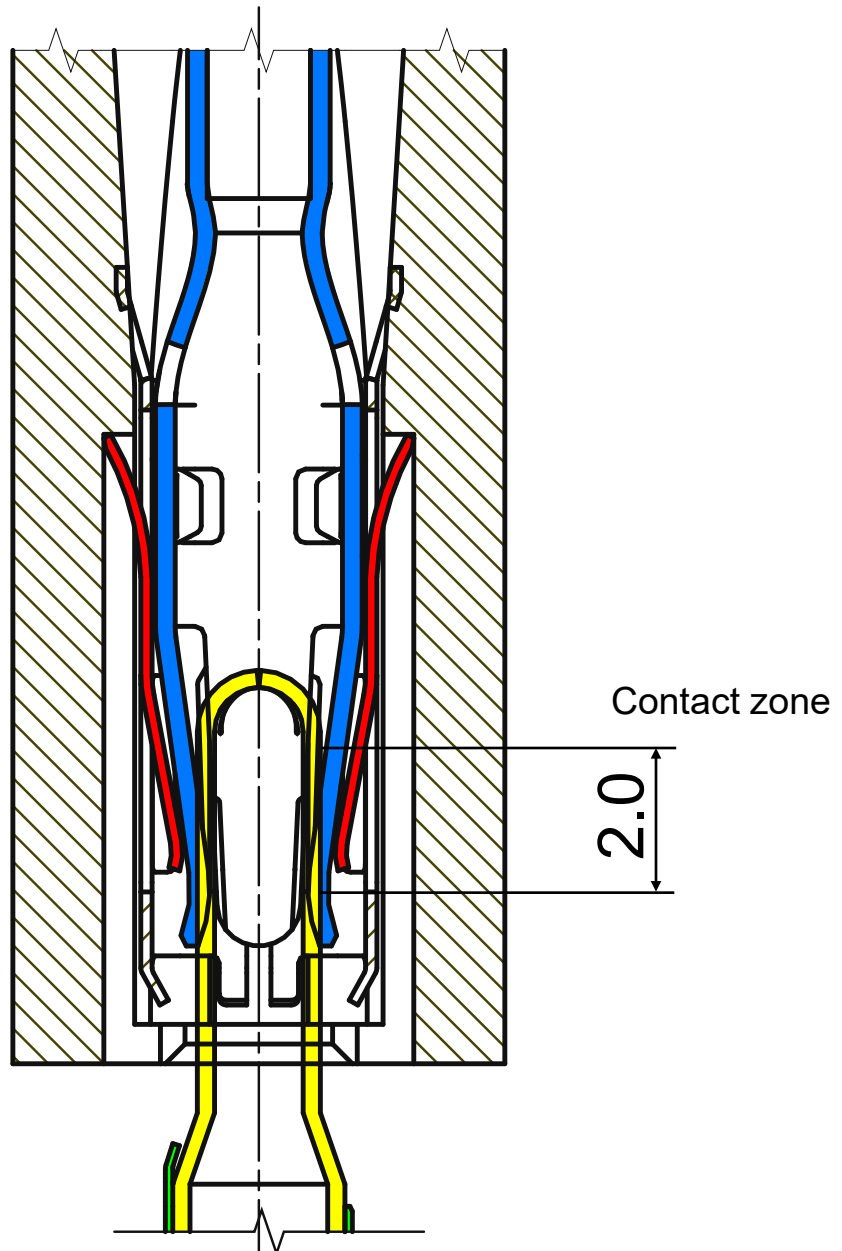

6.8 Engagement and withdrawal forces

VKR - VKS Plus

Results over 10 cycles

Material: CuSn

Plating: Sn

Engagement force

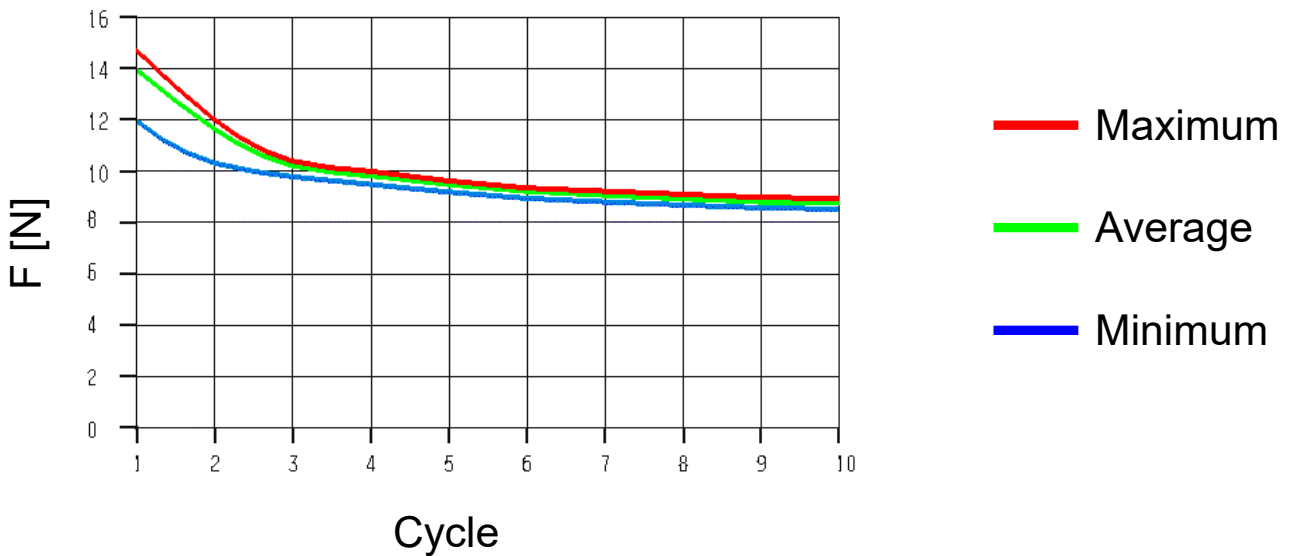

Withdrawal force

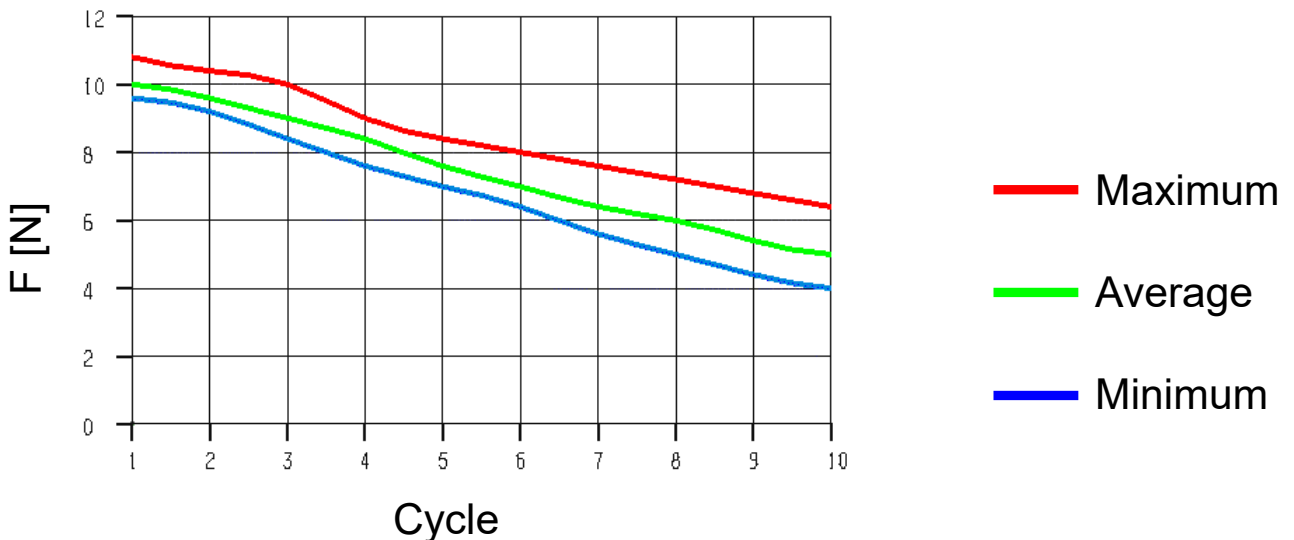

6.9 Spring support force

Spring support force VKR Plus

Material: CuSn

Plating: Sn

Spring support for VKR Plus in the contact area

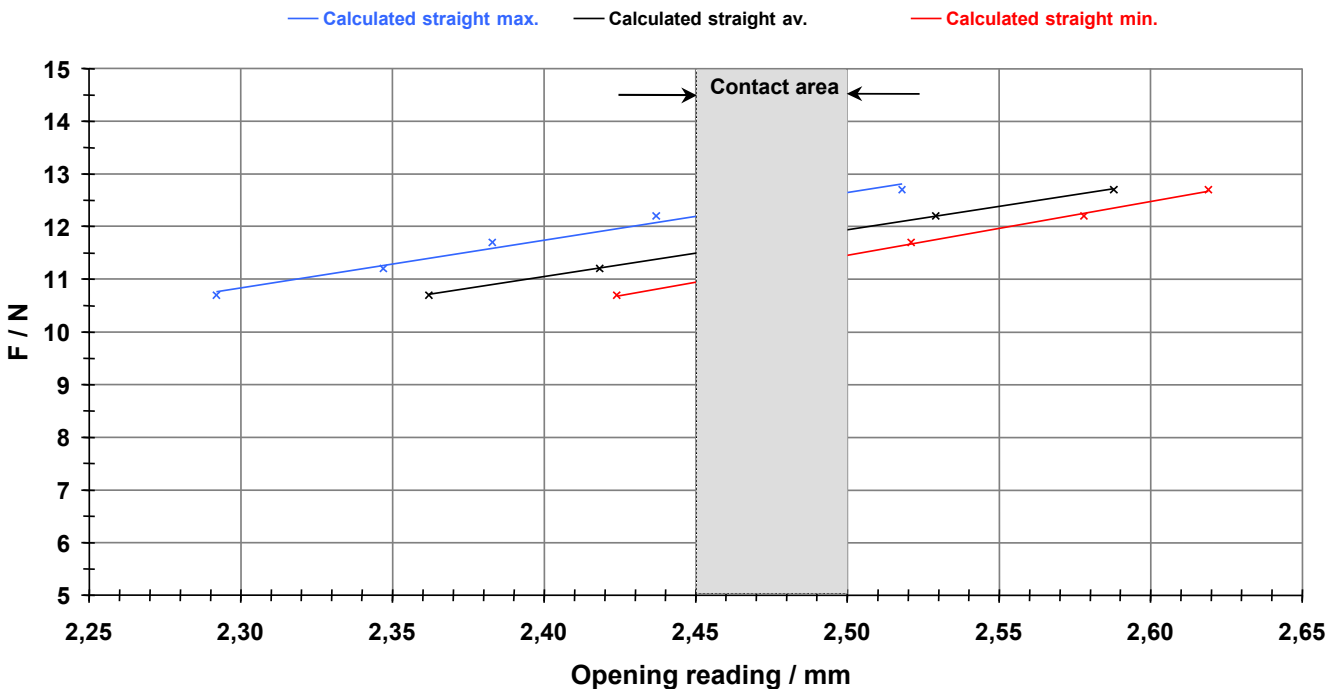

Note: The figures were calculated from seven measurements and cover only a single point within the contact mouth of the VKR terminal. This means that the whole force applied to the four contact points is approximately 12N.

6.10 Crimp measurements

VKR Plus

<u>Nominal CSA</u>	<u>Crimp sizes</u> <u>Wire crimp</u> <u>mm</u>	<u>Crimp sizes</u> <u>Insulation crimp</u> <u>mm</u>
0.50 sqmm	Height : 1.35 ± 0.05 Width: 2.05 ± 0.10	4.90 5.10
0.75 sqmm	Height : 1.40 ± 0.05 Width: 2.05 ± 0.10	5.00 5.10
1.00 sqmm	Height : 1.50 ± 0.05 Width: 2.10 ± 0.10	5.00 5.10
1.50 sqmm	Height : 1.65 ± 0.05 Width: 2.85 ± 0.10	5.30 5.20
2.50 sqmm	Height : 1.85 ± 0.05 Width: 2.85 ± 0.10	5.20 5.20

Example – Wire crimp

0.75 sqmm

1.00 sqmm

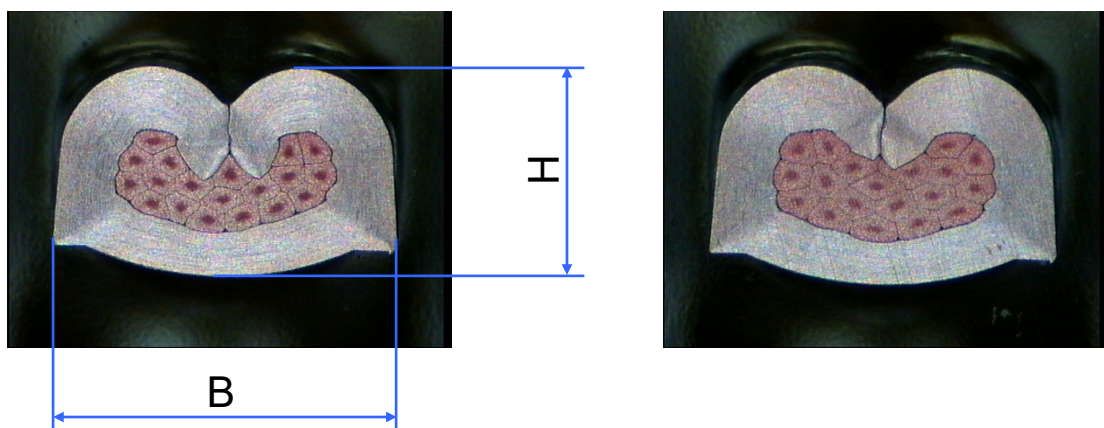

6.10 Crimp measurements

VKS Plus

<u>Nominal CSA</u>	<u>Crimp sizes</u> <u>Wire crimp</u> <u>mm</u>	<u>Crimp sizes</u> <u>Insulation crimp</u> <u>mm</u>
0.50 sqmm	Height : 1.22 ± 0.05 Width: 2.05 ± 0.10	3.90 4.10
0.75 sqmm	Height : 1.32 ± 0.05 Width: 2.05 ± 0.10	4.00 4.10
1.00 sqmm	Height : 1.42 ± 0.05 Width: 2.05 ± 0.10	4.10 4.10
1.50 sqmm	Height : 1.45 ± 0.05 Width: 2.80 ± 0.10	4.00 4.10
2.50 sqmm	Height : 1.65 ± 0.05 Width: 2.80 ± 0.10	4.20 4.20

Example – Insulation crimp (sealed)

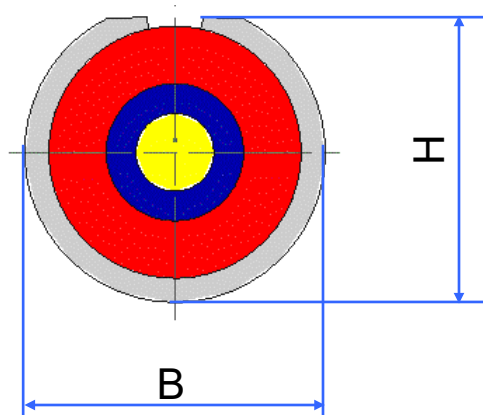

6.11 Crimp tensile strength

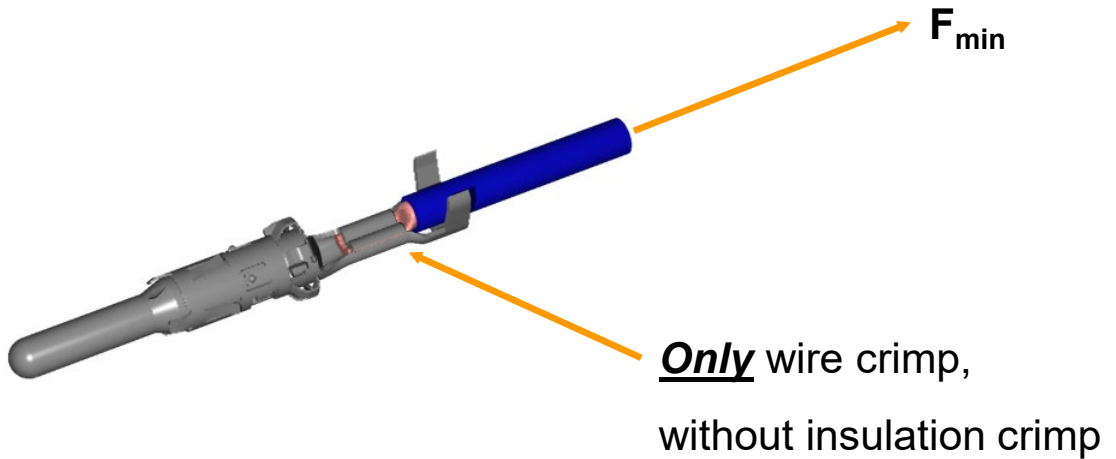

<u>Nominal CSA</u>	<u>Cable construction (FLR)</u>	<u>Force</u>
0.50 sqmm	19 strand x \varnothing 0.18 mm	$F_{min} > 60$ N
0.75 sqmm	19 strand x \varnothing 0.22 mm	$F_{min} > 85$ N
1.00 sqmm	19 strand x \varnothing 0.25 mm	$F_{min} > 108$ N
1.50 sqmm	19 strand x \varnothing 0.30 mm	$F_{min} > 150$ N
2.50 sqmm	19 strand x \varnothing 0.39 mm	$F_{min} > 230$ N

* Measured by Lear T&C

6.12 Vibration requirements

Vibration requirements,

Tests with connected housings,

For full description see DIN 72585-2, March 1996

Test group C

↓
Visual check

↓
Contact resistance

Vibration requirements with free-standing
connected terminals, gradient K2:

30g, 3-way axis for 50h at ambient and 120°C,

supported at 100 mm

contact disconnection: $t < 1\mu\text{s}$, $R < 7\Omega$

↓
Contact resistance

↓
Visual check

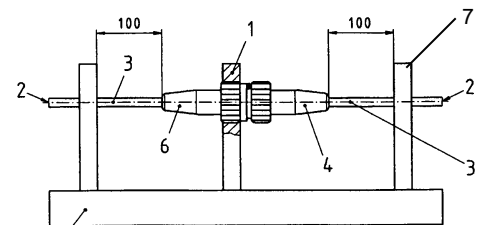
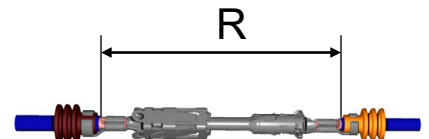

- 1 Metal support
- 2 Connected to current supply
- 3 Cable
- 4 Free-standing connector
- 5 Vibration table
- 6 Free-standing connector
- 7 Joined to vibration table

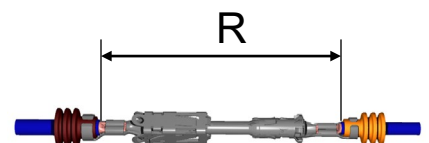

6.13 Contact disconnection

During the total vibration test time of 300 hours, the contact resistance should **not** be :

$>7 \Omega$ for longer than $1 \mu\text{s}$

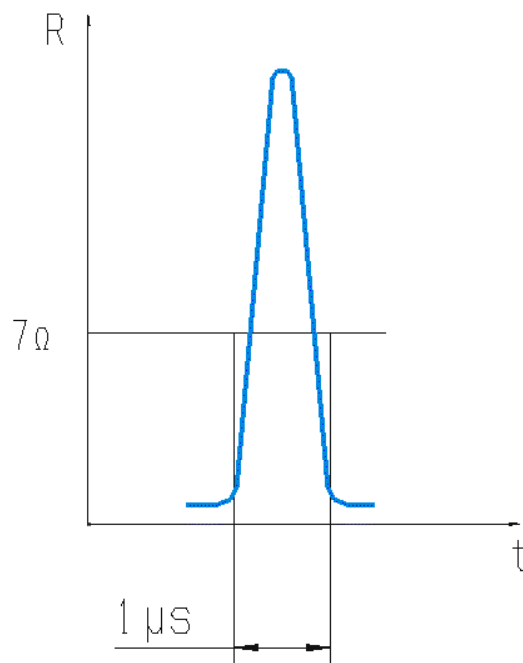
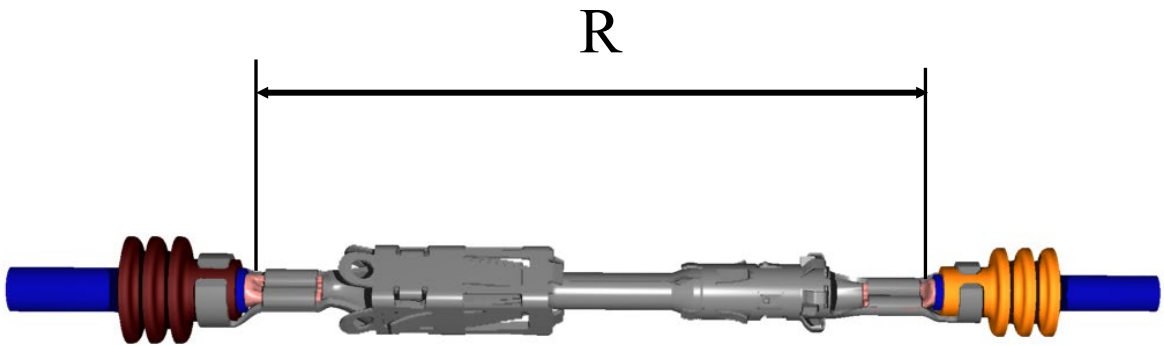

6.14 Climate test

Climate tests with connected housings

For full description see DIN 72585-2, March 1996

Test group K

↓
Visual check

↓
Contact resistance

↓
Insulation resistance

↓
Humidity change

21 days humidity change to DIN 50016 FW24:

23°C/40°C, 83% / 92% rel.H, 1 cycle=24h

↓
Contact resistance

↓
Insulation resistance

↓
Temperature change

50 cycles, gradient K2, - 40°C / +140°C

↓
Contact resistance, Insulation resistance, Visual check

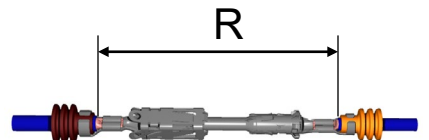
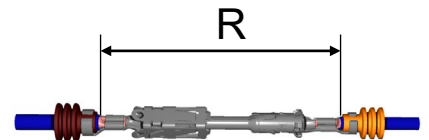

6.15 Water sealing

Water sealing (IP 9K),

Tests with connected housings

For full description see DIN 72585-2, March 1996

Test group L

↓
Visual check

↓
Insulation resistance

↓
Water sealing IP9K
DIN 40050 Part 9, high pressure

↓
jet wash

↓
Insulation resistance

↓
Visual check

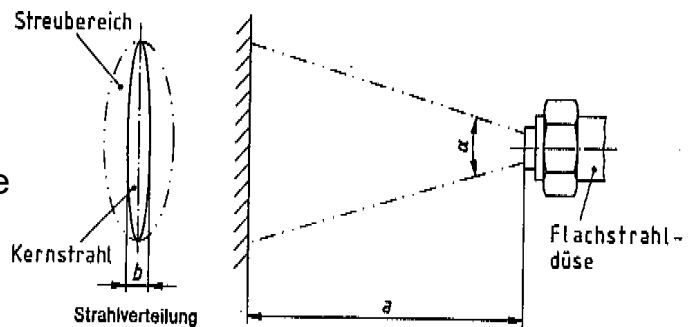

Jet wash and spray distribution for test equipment to certify protection against high pressure water ingress - Water gradient 9K

6.16 Thermal testing

Temperature / Running time

VKR - VKS Plus 1.00 mm²

Tests in housings - 1-way equipped / 1-way nominal current
(19.7 A)

Material: CuSn

Plating: Sn

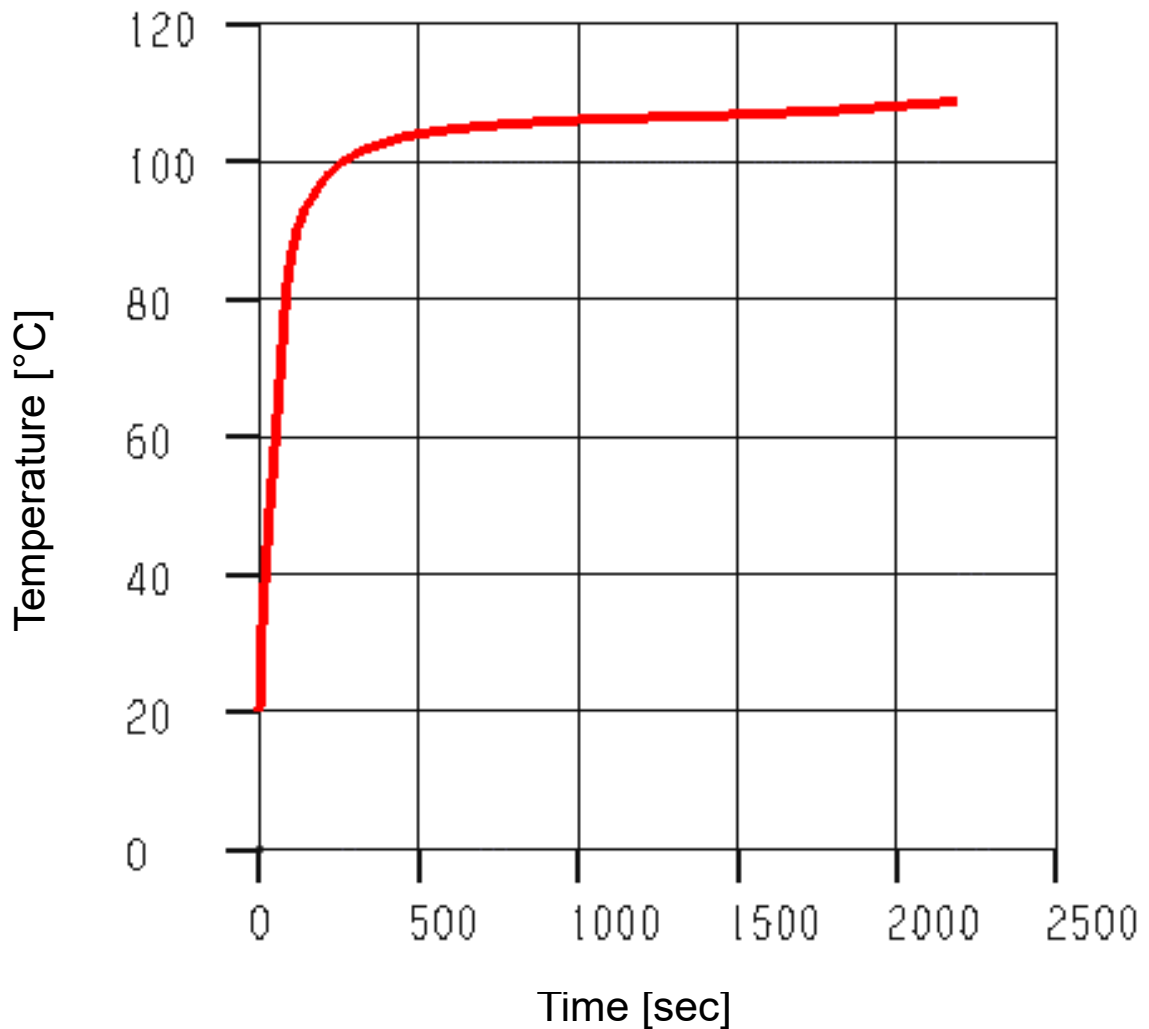

6.16 Thermal testing

Temperature / Running time

VKR - VKS Plus 2.50 mm²

Tests in housings - 1-way equipped / 1-way nominal current
(31.5 A)

Material: CuSn

Plating: Sn

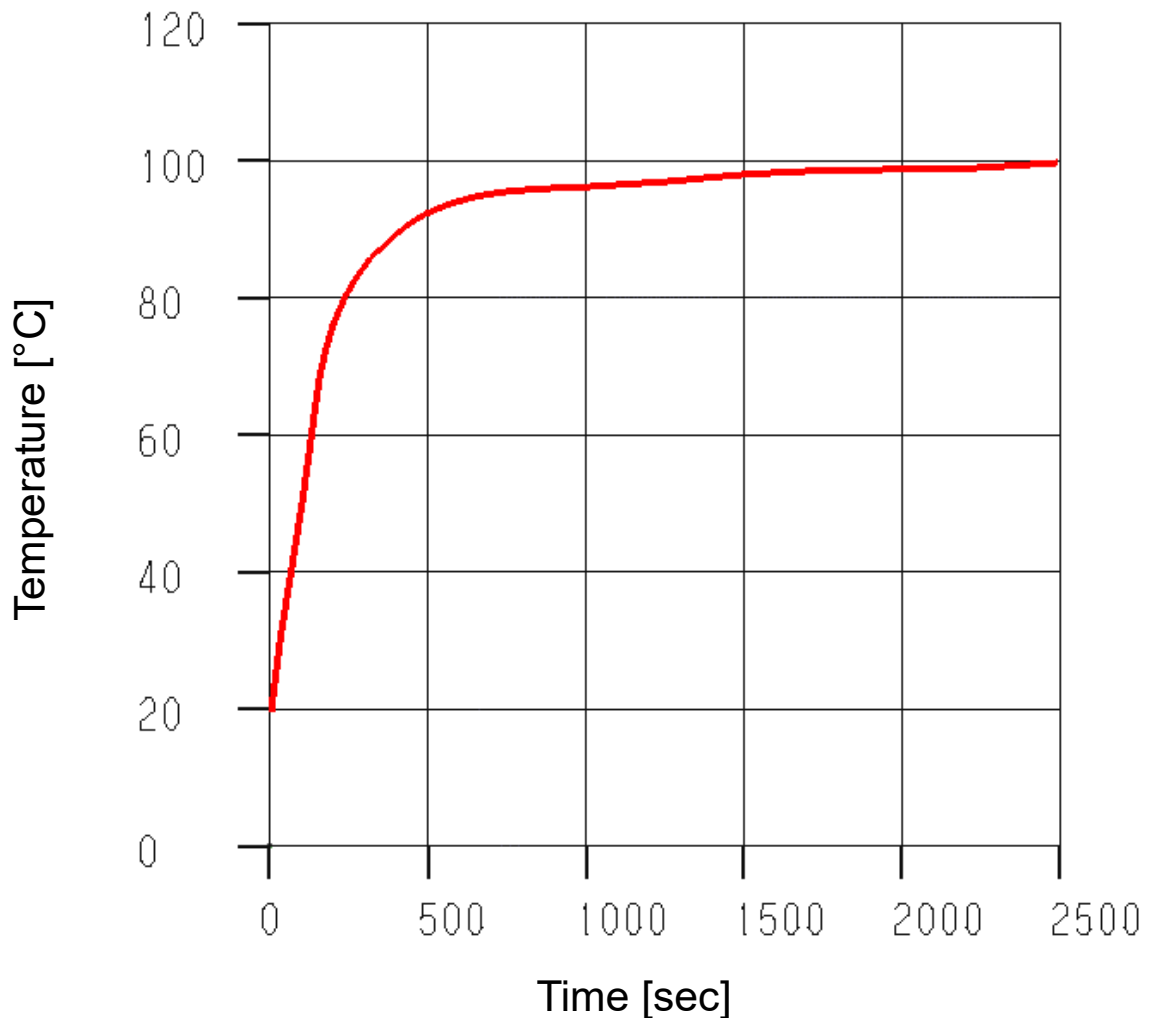

6.17 Dynamic testing

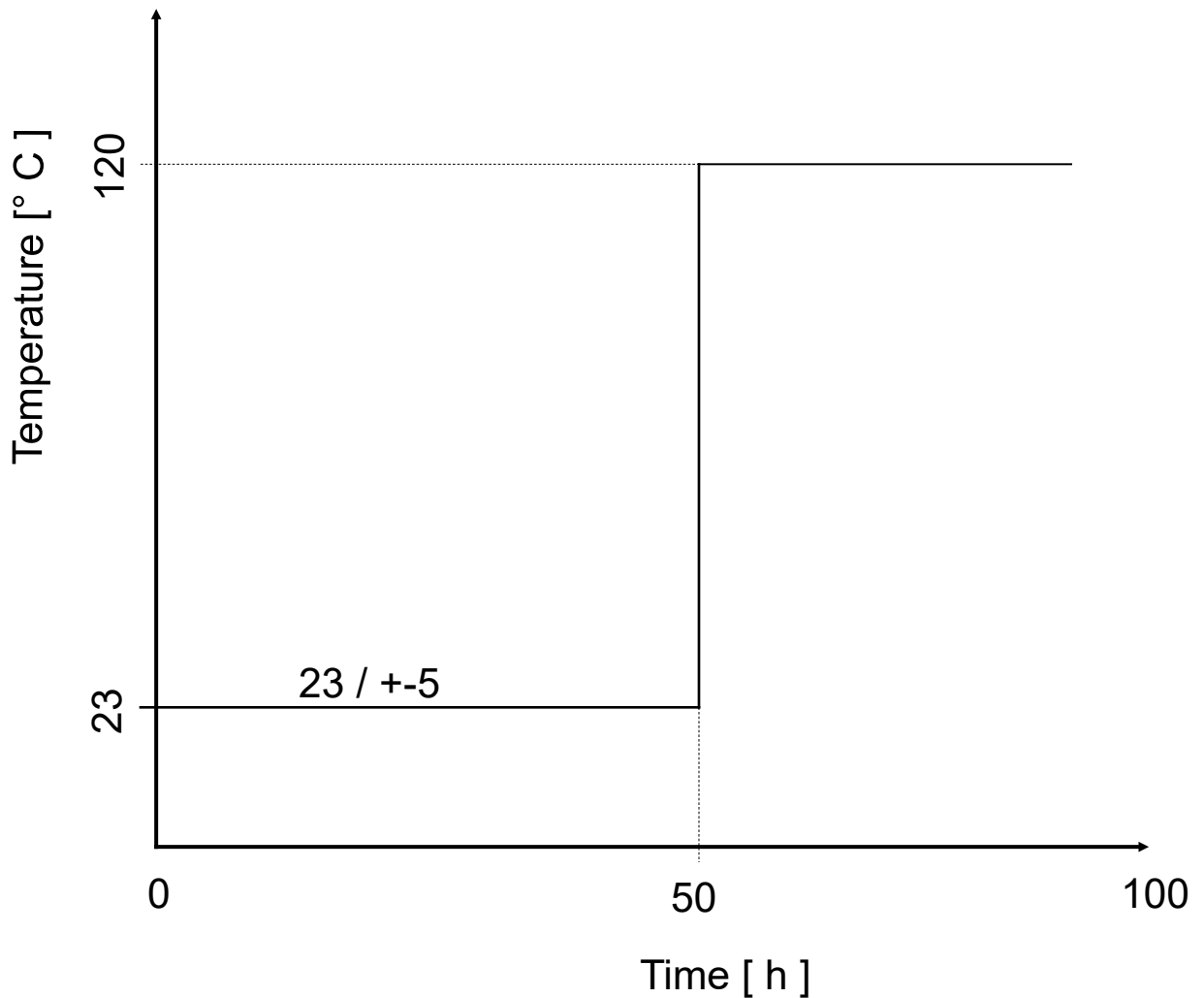

There should be no interruption of the current flow during the test

7. Environmental simulation

Protection against dust penetration:

In accordance with DIN 72585-2 and DIN 40050-9, a dust mist was created from 50% limestone and 50% pulverised ash.

Approximately 2kg of this dust was placed in the test chamber per m³ volume and this suspension was maintained during the test as required.

Conclusion:

Protection against dust penetration was in accordance with the specification.

Industrial climate:

In accordance with DIN 72585-2 and EN ISO 6988, three cycles of 72h in an atmosphere of condensation, sulphur dioxide and humidity were carried out, with a sulphur dioxide density of 2.0 per m³ each cycle.

Conclusion :

Protection against corrosion was in accordance with the specification.

Protection from salt spray

In accordance with DIN 72585-2 and DIN 50021-SS, the test was carried out over 90h with a concentrated test solution spray of 50 +/-5g sodium chloride.

Conclusion :

Protection against salt spray was in accordance with the specification.

8. Chemical resistance

For this test, the samples were sprayed for 5s with each of the chemicals listed below and then connected for 24h at 80°C.

- Diesel fuel to DIN EN 590
- Fuel mixture (70% Diesel and 30% FAM test liquid to DIN 51604-B and DIN 51604-2)
- Motor oil, SAE 30 to DIN 51511
- Brake fluid to DIN ISO 4925
- Antifreeze
- Transmission oil, SAE 80W-90 to DIN 51512

Conclusion:

Protection against these chemicals was in accordance with the specification

9. Documentation summary

Lear T&C - specifications:

- GHW-WN 98011 111 110 Construction rules for open, uninsulated crimped terminals
- GHW-WN 95215 001 001 Test rules for crimped connectors, general requirements and processing rules

Special specifications:

- DIN 72585-2 K2 Version 1996
- DIN IEC 60512-3 Version 2002
- DIN EN ISO 8092-2 Version 1998
- DIN 40050-9 Version 1993
- Applicable regulations, typically standards

10. Benefits

VKR Plus / VKS Plus is a proven design with over four years in service with Volvo Trucks, MAN and Scania

Proven quality record over this period

Potential cost savings when compared to competitor parts

Lear T&C technical and after-sales support

Lear Corporation worldwide support

Possibilities to develop new products using this terminal system in the future

Excellent housing designs – see Truck Catalogue