

# EMC/RFI Board Level Shielding Clips and Cans

Simple designs for fast and easy assembly

The Shield Can and Clip range from Harwin is based on the concept of fast assembly and component protection. Designed for use within an existing SMT circuit board layout, these products are a simple and cost-effective method of shielding vulnerable or EMI-radiating board components.

By using a push-action, the removable shield can is held in place with SMT-mounted spring clips, so no additional secondary soldering operation is required. All soldering takes place on the clip, at the same time as the rest of the PCB components. This eliminates the risk of heat damage and hot spots (caused by hand soldering) affecting the more expensive components located under the can.

The devices under the can are also now accessible at any time, by simply pulling out the can from the clips. Rework and module replacement can be completed, and the can is simply pushed back into place again.

Shield Cans are available in three different material thicknesses (0.3, 0.2 and 0.15mm) to assist matching to different EMI / RFI characteristics. Clips are supplied in a variety of shapes and sizes for added design flexibility.

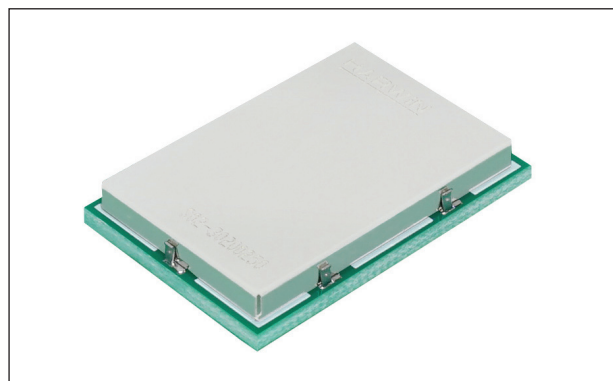

Shield can with S0911-46R miniature clips on PCB

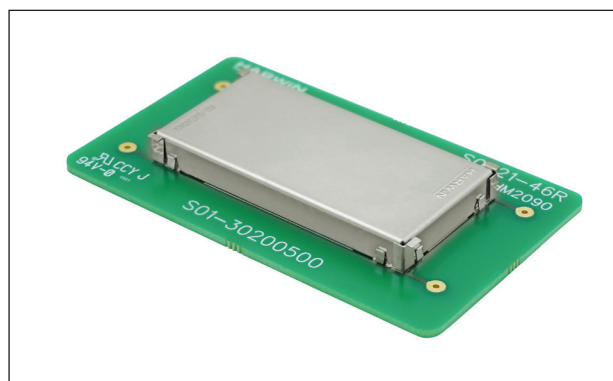

S0921-46R corner shroud shield clip



0.15mm thickness, 10 x 10mm smallest can

## Features and Benefits

No soldering required for can assembly	Eliminate secondary soldering operations and the damage risk from hot-spots
SMT clips supplied on Tape and Reel	Enables fast, fully automated PCB assembly, at the same time as other components
Fast and simple push-fit with SMT clips	Quick secondary operation for reduced assembly costs
Easy to remove in a single action	Simple to rework or upgrade covered devices
Re-usable can once removed	No de-soldering clean-up activity required
Choice of material thicknesses	Different EMI / RFI shielding characteristics
Ready-made can sizes and clips available from stock	Fast delivery, easily purchased from a global authorized distribution network

## Key Applications

Energy	Renewable Sources, Home Energy meters, E-vehicles
Telecommunications	Base Stations, WiFi, Wireless Modules, IOT, Handheld devices
Industrial	Drives and Controls, Robotics, IIOT, Wireless Modules
Motorsport	Wireless communications and Telemetry, Navigation and Tracking, Control Systems
Space	Satellites, CubeSats, Launch Systems
Aviation, Defense, Security	UAVs, Avionics, Aircraft infotainment, Radar, Mobile Communications, Vehicle Control systems, Wireless Telemetry

## Product Features

### Shield Cans

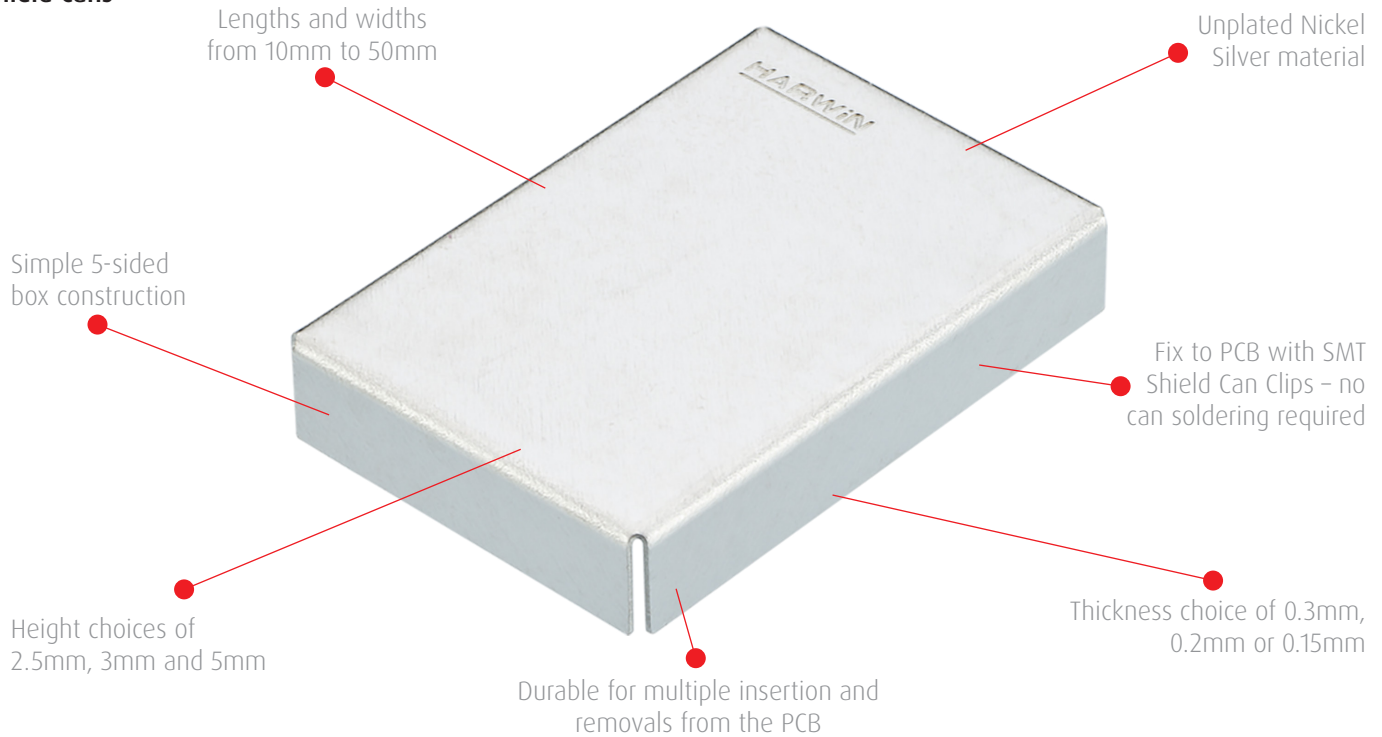

## How to Order

Order Code	Tape & Reel Quantity	Length x Width	Height	Thickness	Compatible SMT Shield Clips
S01-30200500	Loose	30 x 20mm	5mm	0.30mm	S1711-46R, S2711-46R, S0971-46R, S0921-46R
S01-30300500	Loose	30 x 30mm	5mm	0.30mm	S1711-46R, S2711-46R, S0971-46R, S0921-46R
S01-50250500	Loose	50 x 25mm	5mm	0.30mm	S1711-46R, S2711-46R, S0971-46R, S0921-46R
S02-20150300	Loose	20 x 15mm	3mm	0.20mm	S1711-46R, S2711-46R, S0971-46R, S1721-46R, S0951-46R, S0961-46R, S0991-46R, S1001-46R, S0911-46R, S0981-46R
S02-20150300R	900				
S02-25200300	Loose	25 x 20mm	3mm	0.20mm	S1711-46R, S2711-46R, S0971-46R, S1721-46R, S0951-46R, S0961-46R, S0991-46R, S1001-46R, S0911-46R, S0981-46R
S02-25200300R	700				
S02-30200250	Loose	30 x 20mm	2.5mm	0.20mm	S1711-46R, S2711-46R, S0971-46R, S1721-46R, S0951-46R, S0961-46R, S0991-46R, S1001-46R, S0911-46R, S0981-46R
S02-30200250R	700				
S03-10100300	Strip of Tape	10 x 10mm	3mm	0.15mm	S1721-46R, S0941-46R, S0961-46R, S1001-46R, S0911-46R
S03-10100300R	900				
S03-15100300	Strip of Tape	15 x 10mm	3mm	0.15mm	S1721-46R, S0941-46R, S0961-46R, S1001-46R, S0911-46R
S03-15100300R	900				
S03-30100300	Strip of Tape	30 x 10mm	3mm	0.15mm	S1721-46R, S0941-46R, S0961-46R, S1001-46R, S0911-46R
S03-30100300R	900				

## Product Features

### Shield Clips

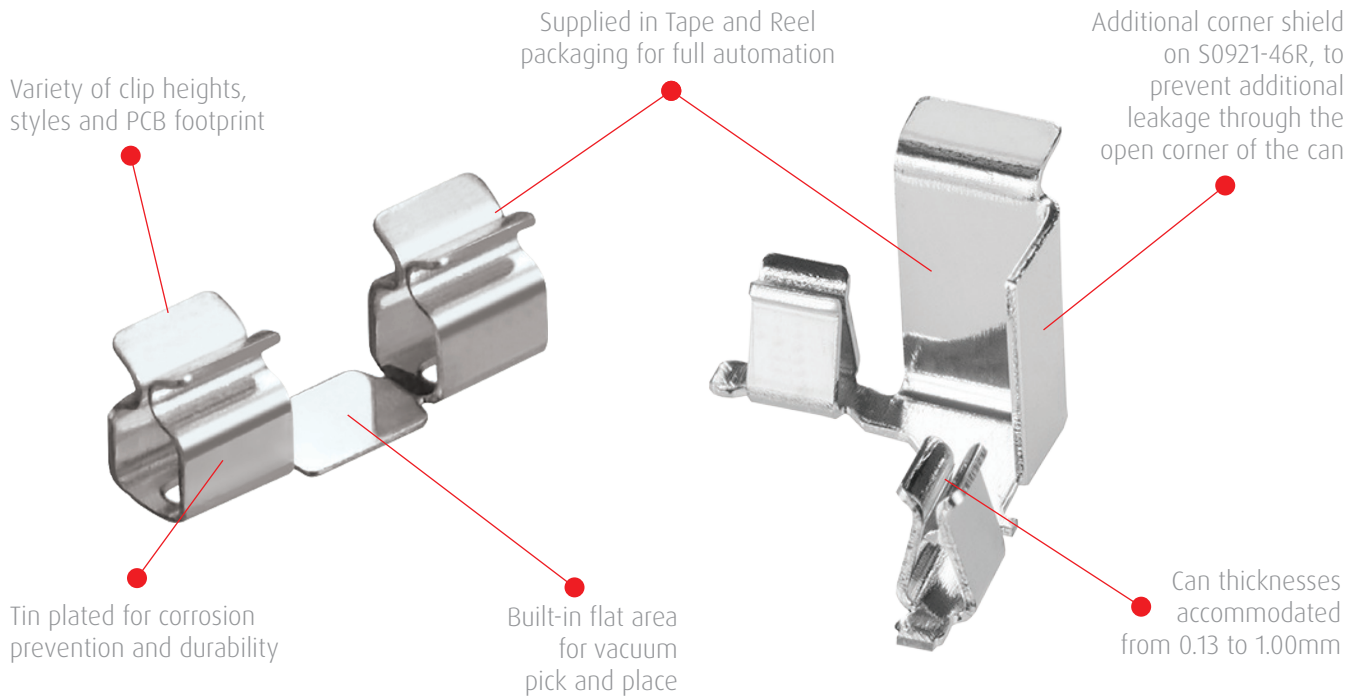

### How to Order

Order Code	Shield Thickness	Height	Base Material	Tape & Reel Quantity	Special Feature
S1411-46R	0.70-1.00mm	3.65mm	Beryllium Copper	1,900	-
S1711-46R	0.17-0.30mm	3.55mm	Beryllium Copper	1,900	-
S2711-46R	0.17-0.30mm	3.55mm	Cupro-Nickel	1,900	-
S0971-46R	0.20-0.30mm	2.00mm	Stainless Steel	5,000	Higher force
S1721-46R	0.13-0.23mm	2.23mm	Beryllium Copper	5,000	-
S0941-46R	0.135-0.16mm	1.00mm	Stainless Steel	10,000	-
S0951-46R	0.20mm	1.28mm	Stainless Steel	10,000	-
S0961-46R	0.15-0.20mm	1.28mm	Stainless Steel	10,000	Higher force
S0991-46R	0.20-0.25mm	1.28mm	Stainless Steel	15,000	Higher force
S1001-46R	0.15-0.20mm	0.80mm	Stainless Steel	20,000	Higher force, Very low profile
S0911-46R	0.15-0.20mm	2.00mm	Beryllium Copper	6,500	Ultra-compact
S0981-46R	0.20-0.25mm	1.30mm	Stainless Steel	6,000	Higher force, Corner style
S0921-46R	0.30-0.40mm	5.45mm	Cupro-Nickel	600	Corner style with Shield

## Shield Can Kit

Everything you need to make your own customized size of shield can! Just add a ruler and a pair of scissors. Ideal for prototyping or low volume manufacturing.

Instructions for use are supplied in the kit or available from the website.

The instruction video is at [www.harwin.tv](http://www.harwin.tv).

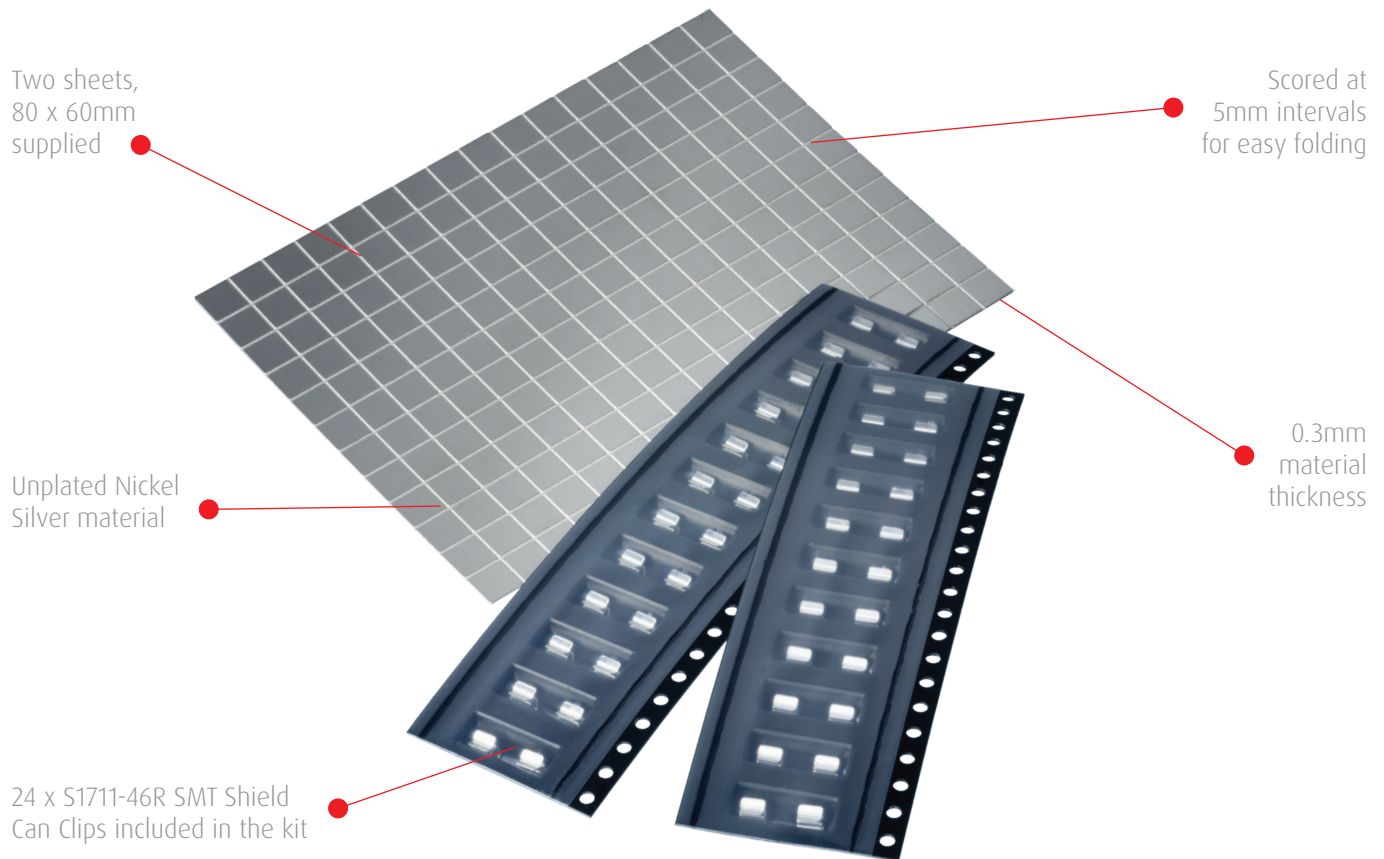

### How to Order

S01-806005KIT

## CONTACT US

**Harwin Europe  
(Global Headquarters)**  
Portsmouth, Hampshire, UK  
E: [mis@harwin.co.uk](mailto:mis@harwin.co.uk)  
T: +44 (0)23 9231 4545

**Harwin Inc (Americas)**  
New Albany, Indiana, USA  
E: [mis@harwin.com](mailto:mis@harwin.com)  
T: +1 603 893 5376

**Harwin Asia Pte Ltd  
(Asia, Australasia)**  
Singapore  
E: [mis@harwinasia.com](mailto:mis@harwinasia.com)  
T: +65 6 779 4909