

AEROSPACE & DEFENSE™

TECHNOLOGY

The Engineer's Guide to Design & Manufacturing Advances

Welcome to your Digital Edition of *Aerospace & Defense Technology* October 2020



How to Navigate the Magazine:

At the bottom of each page, you will see a navigation bar with the following buttons:



Arrows: Click on the right or left facing arrow to turn the page forward or backward.



Introduction: Click on this icon to quickly turn to this page.



Cover: Click on this icon to quickly turn to the front cover.



Table of Contents: Click on this icon to quickly turn to the table of contents.



Zoom In: Click on this magnifying glass icon to zoom in on the page.



Zoom Out: Click on this magnifying glass icon to zoom out on the page.



Find: Click on this icon to search the document.

You can also use the standard Acrobat Reader tools to navigate through each magazine.

Develop better products – faster.

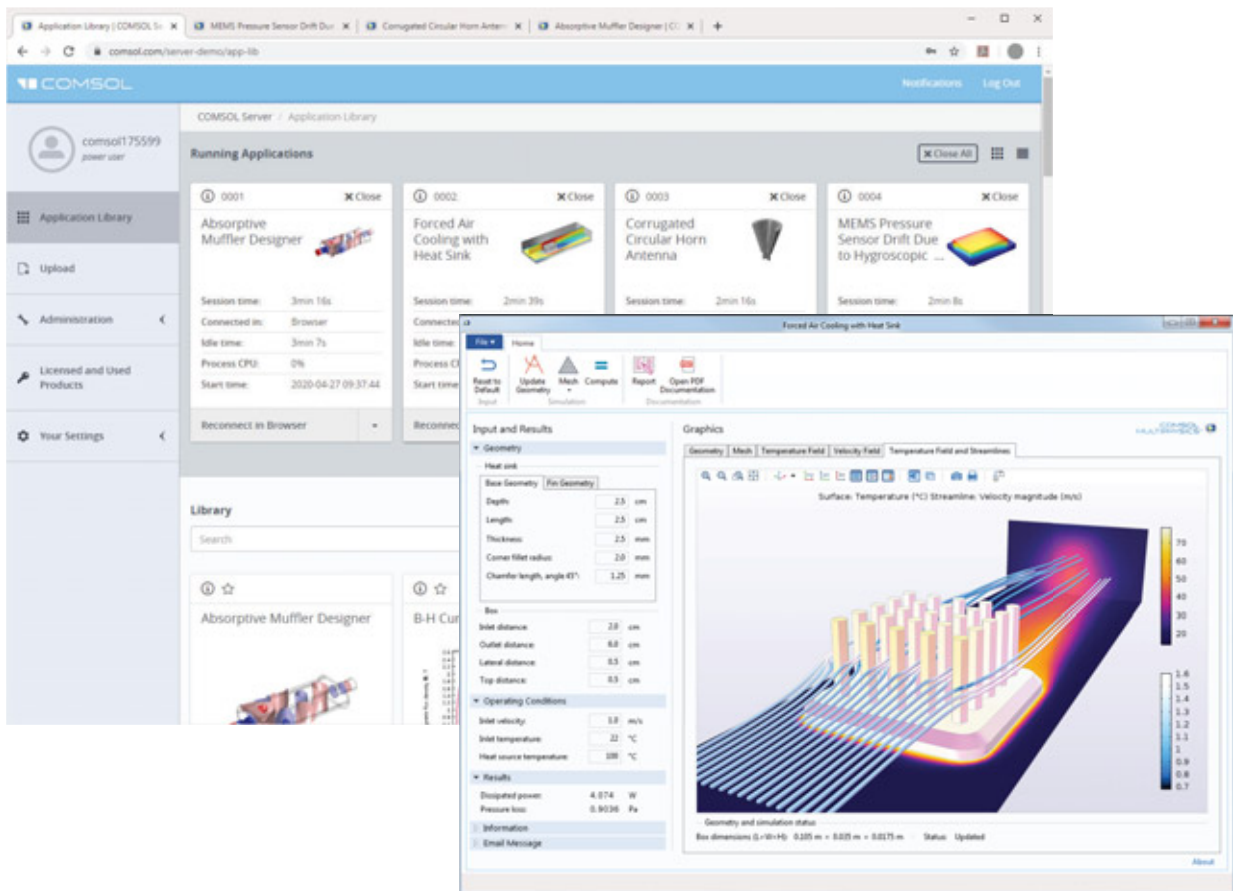

An example of a simulation application in the COMSOL Server™ application library. Application users can find an optimal heat sink design without having any knowledge of the underlying mathematical model.

Industry engineers and researchers are accelerating product development by building numerical simulation applications and deploying them throughout their organizations. COMSOL Multiphysics® enables you to build specialized applications, and COMSOL Server™ and COMSOL Compiler™ help you distribute them to the right contributors at the right time in your product development workflow.

The COMSOL Multiphysics® software is used for simulating designs, devices, and processes in all fields of engineering, manufacturing, and scientific research. See how you can apply it to product development.

[comsol.blog/product-development](https://www.comsol.com/blog/product-development)



Free Info at <http://info.hotims.com/76508-847>

AEROSPACE & DEFENSE™

TECHNOLOGY

The Engineer's Guide to Design & Manufacturing Advances



The Role of
Autonomous Unmanned
Ground Vehicle Technologies
in Defense Applications

Information Warfare –
Staying Protected at the Edge

Designing Connectivity Solutions
for an Electric Aircraft Future

From the Publishers of TECH BRIEFS

Autonomy ON THE Tactical Edge



RUGGED. SCALABLE. **SECURE.**

Designed and tested to strict cyber and environmental MIL standards, the Crystal Group RIA™ rugged server arms UAVs with scalable Intel® processing, 10-32VDC input power, liquid cooling and secure FIPS 140-2 data storage. Crystal Group RIA is easily integrated with UAVs for any domain, making it ideal for autonomous, unmanned and optionally-manned vehicles in battle – when uncompromised performance matters most.

The DoD trusts NIST-compliant, U.S.-based Crystal Group on hundreds of mission-critical programs including Gorgon Stare, Blackjack and Fire Scout, because failure is not an option.



 RIA™



A clear advantage.

SERVERS | DISPLAYS | STORAGE | NETWORKING | EMBEDDED | CYBER
info@crystalrugged.com | 800.378.1636 | crystalrugged.com

Free Info at <http://info.hotims.com/76508-824>

ADVANCING THE INTELLIGENCE OF DEFENSE



ADVANCING INNOVATION FOR OVER 100 YEARS

Advancements in defense technology have helped to reduce casualties and increase intelligence to levels never before thought possible.

We are committed to working with agencies to continue advancement and help provide intelligent defense solutions.



NEW ENGLAND WIRE
TECHNOLOGIES

Manufacturing Custom Wire & Cable
solutions since 1898

603-838-6624 • www.NewEnglandWire.com
Lisbon, New Hampshire USA

Free Info at <http://info.hotims.com/76508-825>



MOISTURE IS THE ENEMY AT THE GATE.

We protect your products from moisture's corrosive effects.



Machinable Desiccants



Custom Desiccants



Indicating Desiccants



Breathing Desiccants

Talk with an AGM Engineer today for a custom designed moisture protection solution.

Call: 1-800-995-5590 or
Email: consult@agmcontainer.com

AGM
AGMCONTAINER.COM



Free Info at <http://info.hotims.com/76508-826>

ATOM DX™ encoder series

Performance in miniature

All-in-one: digital, miniaturization, quality, performance

- All-in-one miniature encoder
- Versatile metrology performance
- Direct digital output
- Compatible with the Advanced Diagnostic Tool (ADT)

For more information visit www.renishaw.com/atomdx

Renishaw Inc 1001 Wesemann Drive West Dundee, IL, 60118
T 847-286-9953 F 847-286-9974 E usa@renishaw.com

www.renishaw.com

Free Info at <http://info.hotims.com/76508-827>





Contents

FEATURES

Unmanned Vehicles

- 6 The Role of Autonomous Unmanned Ground Vehicle Technologies in Defense Applications

Military Data Security

- 11 Information Warfare - Staying Protected at the Edge

Electrical Connectivity

- 14 Designing Connectivity Solutions for an Electric Aircraft Future

Electric Propulsion Technology

- 18 Redesigning the Systems Engineering Process to Speed Development of E-Propulsion Aircraft

RF & Microwave Technology

- 22 Four RF Technology Trends You Need to Know for Satellite Communication Device Design
- 25 Manufacturer Reduces Risk and Improves Quality of Military Radar Receivers

TECH BRIEFS

- 28 Instrumentation for Fabrication and Testing of High-Speed Single-Rotor and Compound-Rotor Systems
- 29 Collection, Processing, and Accuracy of Mobile Terrestrial Lidar Survey Data in the Coastal Environment

- 30 Analysis of Broadband Metamaterial Shielding for Counter-Directed Energy Weapons
- 32 Data Collection Using the MetalMapper in Dynamic Data Acquisition and Cued Modes
- 34 Exploring the Impact of Fuel Data Acquisition Technology on the USMC Expeditionary Energy Command and Control System

DEPARTMENTS

- 36 Application Briefs
- 41 New Products
- 44 Advertisers Index

ON THE COVER

Autonomous ground vehicles possess several benefits in terms of size, affordability and survivability that make them suitable for defense applications as security threats become increasingly more unconventional. There are innovative technologies under development in the unmanned ground vehicles (UGV) industry, from small hybrid systems to future-ready unmanned military vehicle platforms, that will enable them to play an even bigger role in military operations. To learn more, read the feature article on page 6.

(Photo by Grant Turnbull / Shutterstock.com)





Advanced Lighted Pushbutton
Switches and Indicators

Manufactured by
Applied Avionics



12
Internal NEXSYS
Component
Options

There's Never Been a Better Time to Make the Switch

VIVISUN® has set the standard in ruggedized MIL-SPEC avionics switches and indicators for more than 50 years. With advanced internal NEXSYS® component options, our products simply outperform the competition.

If you're looking for personal customer service, worldwide factory support and the industry's fastest delivery, it's time that you make the switch to VIVISUN, manufactured by Applied Avionics.

Speaking of making the switch, our easy-to-use Part Configurator allows you to design a switch and get a complete part number 24/7 as part of our online paperless ordering process.

Ready to make the switch? Visit our website at:
www.AppliedAvionics.com/VIVISUN
 Sales and Support: +1 (888) 848-4786

©2019. VIVISUN® and NEXSYS® are registered trademarks of Applied Avionics, Inc. All rights reserved.

Do you just feel like there's got to be a better way?

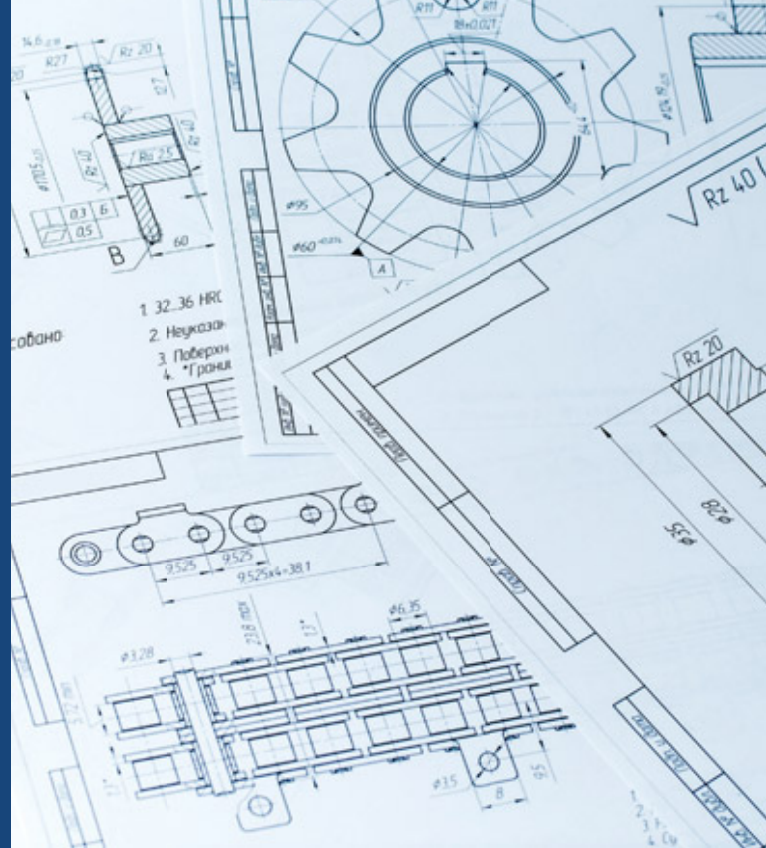

So do we. Let's talk about designing smaller, more reliable and less expensive devices

The most rewarding projects involve a breakthrough — a new way to solve an old problem. Minco engineers stand ready to listen to your requirements and show you novel ideas for creating smaller, less expensive and higher performing devices. Lately, we've helped customers achieve this by integrating circuits, heaters and sensors. If you're ready to explore new ideas call Minco at 763.571.3121. Or send email inquiries to design.engineer@minco.com.

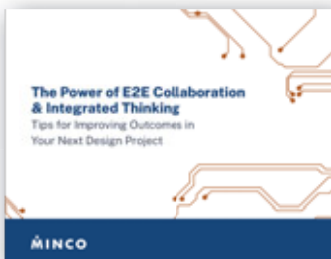

FREE INTEGRATION E-BOOK:
Want to explore integration ideas on your own?

Download our new e-book at minco.com/integration



7300 Commerce Lane NE | Minneapolis, MN 55432

minco.com

Free Info at <http://info.hotims.com/76508-829>



The Role of Autonomous Unmanned Ground Vehicle Technologies in Defense Applications

Artificial Intelligence (AI), which is also being hailed as a part of Industrial Revolution 4.0, has established its presence across myriad fields in recent years. AI has become somewhat of an umbrella term for a host of scientific and technological evolutions across various applications, computer sciences, and use cases.

Known predominantly as a series of technologies that promote intelligent execution of tasks in machines, AI is rapidly establishing itself as a reality in the current technological landscape, as well as a robust solution for future evolutions. The success of the AI field is characterized by the ever-increasing availability of computing power and data, backed by advancements in electronics miniaturization and machine learning (ML), among others.

While AI already has a significant presence across various commercial

sectors such as retail and banking, its scope for defense and security is becoming more prominent in recent years. Artificial intelligence can be used for a plethora of defense applications including novel weaponry development, command and control of military operations, logistics and maintenance optimization, and force training and sustainment.

The integration of AI is also bringing more autonomy to military applications, particularly in unmanned machines and robots. These range from aerial autonomous vehicles





Nations worldwide, including the US, UK, Estonia, and Russia, are becoming more aware of the merits of UGVs as combat vehicles and force enablers.



The Ripsaw Unmanned Ground Vehicle being developed by the Remote Weapons Branch of the Armament Research, Development and Engineering Center (ARDEC). (Photo: U.S. Army)

to unmanned ground vehicles that can function with the help of environmental sensors and AI with little to no human intervention.

Autonomy in Land Defense Vehicles

The first truly autonomous vehicle came into being in 1984, developed by the ALV and Navlab projects from Carnegie Mellon University. Various research and development efforts have been undertaken since then, giving rise to a number of advanced Unmanned Ground Vehicles (UGV) prototypes. Advancements in technology have ex-

panded the use of robotic autonomous vehicles across many fields in addition to UGVs, including Unmanned Under Water Vehicles (UUV), and Unmanned Aerial Vehicles (UAVs). UGVs are vehicles that operate on the ground, without the need for human presence on-board. They are the land counterparts of marine and aerial unmanned vehicles. All of these vehicles play integral roles in enhancing performance, efficiency, and safety across various applications, including military and civilian.

Unmanned ground vehicles are classified into two broad types, remotely

operated and autonomous. Autonomous unmanned ground vehicles comprise several technologies that allow the machine to be self-acting and self-regulating, sans human intervention. The technology was initially developed to aid ground forces in the transfer of heavy equipment. However, the technology has witnessed significant evolution over the years, giving rise to more tactical vehicles designed to assist in surveillance or IED search-and-destroy missions. For example, a modular UGV developed jointly by Milrem Robotics and QinetiQ North America, dubbed Titan UGV, is designed to undertake multiple missions, including transport, reconnaissance, and rescue, and can be reconfigured to add or modify functionality as needed.

Autonomous ground vehicles possess several benefits in terms of their size and affordability, in addition to high survivability, which makes them ideal for defense applications across the globe, as security threats continue to become increasingly more unconventional. Nations worldwide, including the US, UK, Estonia, and Russia, are becoming more aware of the merits of UGVs as combat vehicles and force enablers. A range of UGVs are being developed, from the robotic combat vehicle by Textron, to the TheMIS UGV by Milrem, to Russia's Uran-9 unmanned ground vehicle. Available in different sizes and configurations, unmanned ground combat vehicles can cater to diverse missions and fulfill many roles, taking a step closer to the seamless integration of ground forces and unmanned systems.

Small UGV Models Are Poised To Make a Big Impact

In keeping with recent trends, unmanned military vehicles are growing increasingly smarter and smaller. Small unmanned ground vehicle technologies help make battlefields safer for humans. These systems demonstrate a robust ability to undertake several high-pressure tasks, including firefighting, public safety, and the delivery of supplies and medications to patients in remote areas. They are especially helpful in defense applications, as their miniature size allows them to reach and operate in re-

MILITARY AND AEROSPACE INTERCONNECTS AT THE READY



From high-volume production, to low-volume customized products, MilesTek is your source for military, aerospace, communications and industrial interconnect solutions. With quick turnaround and same-day shipping from our stock of more than 10,000 highly reliable products, MilesTek is at the ready to help meet your project deadlines.

The MilesTek Advantage:

- Large In-Stock Inventories
- Same-Day Shipping
- Prototype Development
- CAD Design Capabilities
- Multiple Testing Solutions
- Expert Technical Support
- ISO 9001:2015 Registered



866-524-1553 • MilesTek.com

MilesTek[™]
an INFINIT[®] brand

Free Info at <http://info.hotims.com/76508-830>



remote locations that may be inaccessible to humans.

The Dragon Runner 10 (DR-10) is a small 10-pound UGV developed by QinetiQ North America. Operated with an easy-to-use controller, it is equipped with night and day cameras as well as communication transceivers, in order to allow operators to gain a comprehensive understanding of the site from a remote location. The UGV is able to place counter-IED charges and deliver remote sensors, making it an ideal fit for the US Army's objective of extended tunnel mapping.

What Is on the Horizon for UGV Technology?

There are several innovative technologies under development in the unmanned ground vehicles industry, from small hybrid UGV systems to future-ready unmanned military vehicle platforms. To illustrate, Robotics Research, an autonomy and robotics technology developer for commercial and defense applications has created the Pegasus Mini, a mini version of the transformable hybrid Pegasus (UAV/UGV), which can operate both on the ground and in the air. This hybrid UGV technology delivers a range of capabilities for different sectors, from law enforcement, to first responders, to the military. The Pegasus Mini combines the benefits of both land- and air-based unmanned vehicles, featuring sophisticated GPS functions and high-speed, fully autonomous flying and driving capabilities. It can be used for rapid response, public safety, search and rescue missions, inspection, and lots of other applications across the spectrum.

Meanwhile, BAE Systems has introduced a new UGV platform prototype, called the Robotic Technology Demonstrator (RTD). The system, which has been built as a rolling lab for the integration of emerging autonomy with lethality technology testing, is designed specifically for battlefield applications. The platform is flexible and future-ready, designed to be adaptable to various future developments in sensors, weapon systems, and other payloads.

A team of engineers and scientists from the Army Research Laboratory,



The Next Generation Combat Vehicle's manned-unmanned teaming concept would leverage a protected tether between the NGCV Optionally Manned Fighting Vehicle and the Robotic Combat Vehicle in order to give soldiers the capability to safely engage in combat with autonomous systems while safely remaining outside of enemy range. (Photo Credit: U.S. Army)



A soldier operates a remotely piloted ground vehicle. The next step in the evolution of UGV technology is vehicle autonomy.

supported by the U.S. Army Combat Capabilities Development Command, is focusing on developing new unmanned vehicle technologies to promote military modernization. To that end, the team is working on adapting an energy-efficient power generator, which has been used predominantly for household energy applications, for use on military vehicles. The research team is evaluating the efficacy of a Stirling cycle generator as a propulsion aid for autonomous ground vehicles. The generator is known for its virtually silent nature, high efficiency, low emissions, and long life. This effort marks the first time that a generator of this scale is being investigated as a possible UGV propulsion technology. The team has created a host of novel

technologies to ready the generator for propulsion applications. These include a DC-DC power converter to convert electrical energy from the Stirling generator to the electrical bus of the vehicle.

Additionally, a Clearpath Robotics Warthog UGV, with operational capacity both on land and in water, was modified, leaving behind just the original wheels and chassis. Then, a new lithium-titanate battery along with a new battery management system was developed, to ensure the safety and efficiency of the batteries.

This article was written by Saloni Walimbe, Research Content Developer at Global Market Insights (GMI) (Selbyville, DE). For more information, visit <http://info.hotims.com/76508-500>.

Information Warfare

Staying Protected at the Edge

On April 1, 2001, a United States Navy EP-3E ARIES II signals intelligence aircraft and a Chinese People's Liberation Army Navy J-8II interceptor fighter jet collided above Hainan Island, China. Per protocol, the EP crew scrambled to destroy sensitive key-management data onboard the aircraft. However, the team was interrupted by opposing soldiers, and as a result failed to destroy cryptographic keys and other highly sensitive information on the plane. In a matter of seconds, U.S. secrets were in the hands of another nation, including intelligence documents, NSA employee names, defense plans, and other confidential documents.

This exposure of information set back U.S. intelligence enough to impact the nation's defense strategy for years. Had this aircraft been equipped with hardware-embedded cyber defense capabilities such as instant secure erase (ISE), the complete compromise of sensitive data could have been prevented — U.S. troops would have been able to destroy the data with the press of a button. Solutions that integrate with ISE capabilities built into modern hard drives would have protected this sensitive data.

In 2013, Edward Snowden, a former contractor for the CIA, left the U.S. after sharing quantities of classified details about extensive internet and phone surveillance by American intelligence.

Once again, the consequences of this disclosure had a chilling effect on U.S. intelligence missions. In 2017, WikiLeaks published a series of documents claiming that the CIA hacked users' devices exploiting zero-day vulnerabilities.

Looking back, we know those data dumps could have been detected and prevented. With an integrated user and entity behavior analytics policy management protocol, excessive downloads would be detected and an information rights management solution would prevent the extraction of data or remotely destroy data when needed.

Today we're well into an era where everything is data-driven, including the



RCS7450-24 Rugged Network Switch with IP Secure Module



confidential information contributing to some of the nation's most important military decisions. This problem impacts many grid-modernization markets, such as power distribution. Traditional perimeter security and even moving to the cloud isn't enough — securing the sheer volume of data being transmitted and collected has to start at the hardware level.

Secure Data in Action

It's mission-critical for military formations to communicate and transmit data across platforms and up and down the chain of command. However, this broadens the attack surface, creating openings for various data security threats — including the enduring danger of equipment-tampering, whether from the unintentional purchase of counterfeit equipment, hardware intercepted and compromised in-transit, or evolving attacks on data-in-motion, and on network locations that aren't well-monitored.

A robust integration of hardware roots of trust that can maintain a cryptographic list of trusted components and detect any malicious tampering will help prevent and alert users to compro-

mised systems. Counterfeit equipment, on the other hand, can only be solved by a mature supply chain integrity review process that ensures the equipment is sourced from and provided by trusted suppliers. Furthermore, comprehensively safeguarding against counterfeit goods requires integrators to perform holistic checks when they receive equipment for assembly.

The “guns, guards, and gates” mentality for security has shifted. Given the massive amounts of data produced and consumed by military systems and networks, it's no longer a practical way to approach data-protection. Safeguarding today's systems requires the integration of core capabilities, including encryption, key management, attestation services, and data-at-rest and data-in-transit security measures along with active information monitoring. Integrating these capabilities, which are available in today's hardware components and operating systems, and from security software vendors, can better ensure confidential information remains contained in the event of an emergency or cyberattack. These core capabilities enable a system to be hardened with active configuration man-

agement, which decreases the likelihood of a successful malware attack and increases the ability to detect insider data theft or tampering.

As they prepare to deploy to dispersed locations around the world, commanders increasingly are turning to COTS-based computing hardware as a way to provide IT-based capabilities in transit and in theater. Under the ongoing threat of equipment-tampering and evolving attacks on weapons systems' data-in-transit across military networks, there is a need for streamlined, trusted, and secure servers rugged enough to withstand extreme tactical environments and demands. While outfitted for military use, these technologies increasingly are integrating tools favored by the commercial sector, particularly the financial services industry. That includes broader adoption of machine learning and artificial intelligence to execute a range of functions, including detecting abnormal behavior, automating virtual resources, establishing a robust baseline for scalable deployment of trusted systems, and implementing encryption and access control.

Consider, for example, a forward-deployed special operations team that is dispersed across the globe. As they move through and operate in zones where there will be inevitable attempts to compromise their systems and data, it's critical they can communicate about sensitive matters without risking detection or unintentionally releasing information. The ability to encrypt communications and render data useless to an adversary when needed is a force-enabler in this scenario — and in untold other military and intelligence operations.

Tactical operators can also benefit from cybersecurity solutions in rugged hardware on the ground. Small command posts, for example, are continuously coordinating intel and other classified information. That data sits on hard drives and networks in storage and needs to be encrypted and cloaked, with the ability to wipe the data in the event of a compromise. Through the use of network attached storage (NAS) solutions that provide instant data destruction, dual layers of encryption, and inte-



A MIL-SPEC modified Seagate solid state drive.



grated key management, operators can better secure highly confidential data, both in storage and in transit, at the hardware level. Leveraging Trusted Computing Group Opal Standard-compliant hard drives that have completed FIPS 140-2 cryptographic review of the NAS enables the use of cryptographic data erasure that's in line with NIST 800-88 Guidelines for Media Sanitization.

Securing the Supply Chain

To deploy cybersecurity at the hardware level, it's essential first to ensure the hardware was developed securely and isn't vulnerable itself, by gaining full visibility into the supply chain. Unfortunately, according to a National Defense Industrial Association survey, less than 60% of small and medium-sized defense contractors even read the Defense Federal Acquisition Regulation Supplement (DFARS), which specifies the bare minimum security standards for contractor information systems. This general unpreparedness can be preyed upon by nation-states and rogue actors looking to obtain confidential information or gain access to restricted networks.

Per DFARS subpart 239.73, agencies must have complete trust in their supply chain to avoid tampering or the use of vulnerable third parties for critical systems. This requires prime contractors to have visibility that ensures end-to-end chain of custody security and mitigates vulnerabilities. Knowing where and how the hardware is being manufactured adds another layer of security. Suppliers should have the capabilities to trace every component of the supply chain, from the raw materials through the production phases to the delivery of the final warrantied product. This increased visibility dramatically reduces the risk of vulnerable components making it into the final product.

Given the prevalent use of third-party suppliers and open-source code, government agencies have to consider suppliers with extra security features beyond what's standard in goods and services. These features should include, for example, tamper-evident solutions and tamper-resistant elements starting at the chip, board, drive, network, and software levels.



FORCE™ RS1104 Rugged 1U Server with 8- or 16-port GbE Switch

A "Tamper-Resistant" Future

Securing data shared and stored on the battlefield will require hardware with built-in cybersecurity features to serve as the frontlines of defense and national security. Solutions with capabilities such as FIPS 140-2 certified data-encryption, near-zero latency, instant data destruction, and integrated key management, are necessary to prevent crippling attacks on U.S. military and intelligence in the coming years.

As the U.S. defense pivots away from a "guns, guards, and gates" approach to security, it will be vital that cybersecu-

rity defense starts on the ground. Hardware that is secure against physical and digital threats will only continue to evolve as the first line of defense against threats targeting sensitive, confidential data held by the military and intelligence communities. As edge computing grows in adoption and emphasis, this only reinforces the need for strong protection at the farthest reaches of tactical operations.

This article was written by Jim Shaw, Executive Vice President of Engineering at Crystal Group (Hiawatha, IA). For more information, visit <http://info.hotims.com/76508-501>.

AirBorn

Introducing Rocket® Macro Ds

- Save space: fit three, 150 position Rockets in the space of a single 151 position, D38999 — shell size 23
- Crimp removable, customer terminated contact system — install multiple times
- Rugged design, ideal for panel-mount installation
- Signal & power, Rocket delivers both — options for 8, 16, 20, 50, 74, 100 and 150 pos.

www.airborn.com



Designing Connectivity Solutions for an Electric Aircraft Future

The levels of voltage and current needed in electric-powered vertical takeoff and landing aircraft (eVTOL), personal air vehicles (PAVs), and rotorcraft systems are high and going higher. That's because electric propulsion motors, inverters, controllers, batteries, and sensor-laden electric aircraft require significant amounts of power.

High voltages and high kW peak outputs present many implementation challenges. Designers can meet these challenges by understanding how proper product selection and a "follow-the-wire" design approach enable high-power connectivity solutions. Some of the hurdles that designers need to overcome include the following.

Electrical Challenges

Preventing Partial Electrical Discharge — the need to minimize corona effects, voids, and cavities that may cause insulation breakdown and electrical treeing.

Managing high voltage (HV) in the air is more complicated than on the ground. HV can ionize surrounding air, which then becomes conductive, producing a corona discharge. The corona effect is responsible for electrical power losses through voids, cavities, and electrical treeing. A self-sustaining ionizing discharge can initiate electrical arcing, potentially igniting a fire. Selecting materials with dielectric properties suited to HV conditions such as corona-resistant polytetrafluoroethylene (PTFE) can minimize risks

of corona discharge due to insulation breakdown.

Encountering Critical Voltage Stresses — the need to use appropriate techniques that protect against different voltage gradients.

Different techniques are used to protect conductor parts depending on the characteristics and strength (voltage gradient) of the electrical field around the conductors (Figure 1). With relatively low-energy corona effects, connectors that use conductors with large radii and designs that avoid sharp points and edges, help minimize air ionization. To protect against air ionization breaking down the dielectric between pins, each pair of conductor pins must maintain an adequate clearance distance as measured through air. These



values will change as a function of altitude and temperature.

Electrical discharges can also occur on or close to the insulation surface. A localized, partially conductive path on the insulation surface is termed "arc tracking." To minimize electric discharges along the insulation's exterior, each pair of conductive parts (including the binding surface of equipment) must maintain adequate creepage distance as measured on the insulation surface. Creepage distance is typically equal to or larger than clearance distance. Minimum creepage distance can be determined by the insulation's Comparative Tracking Index (CTI).

Avoiding Arc Tracking Damage — the need to minimize breaches in insulation to avoid electrical arcing between wires.

Current on the outer surface of polymeric insulators has the ability to create carbon tracks that damage insulation. Carbon tracks can cause the insulator to lose its dielectric properties and become an electrical conductor instead. Electrical arcing can then occur across the conductive path, resulting in power loss, with a high probability of ignition. Maintaining proper creepage distance and using insulation materials that maintain their dielectric properties in HV conditions are critical.

Handling High Network Operating Voltages (>3kV DC) — the need to select relays and contactors that can withstand extreme electrical stress.

High network operating voltages impose significant demands on relays and contactors used for propulsion motor power switching, battery charging management, comfort heating for passengers, and other auxiliary functions. HV relays and contactors are available to meet demanding peak load capacity, operating temperature, coil efficiency, short-circuit protection, breaking capacity, and other critical requirements, such as robust shock and vibration performance.

Dealing with Skin Effect — the need to minimize opposing eddy currents to reduce the effective resistance of conductors at higher frequencies.

When determining proper shielding and filtering for electromagnetic compatibility (EMC), designers must ac-

count for skin effects, which is the tendency of AC to flow close to the surface of a conductor. Skin effect is the result of eddy currents induced by the changing magnetic fields of alternating current,

and therefore, is a factor in nearly every AC design. Printed circuit board (PCB) traces and other aspects of AC power circuits can be designed to negate skin effect, but expert planning is required.

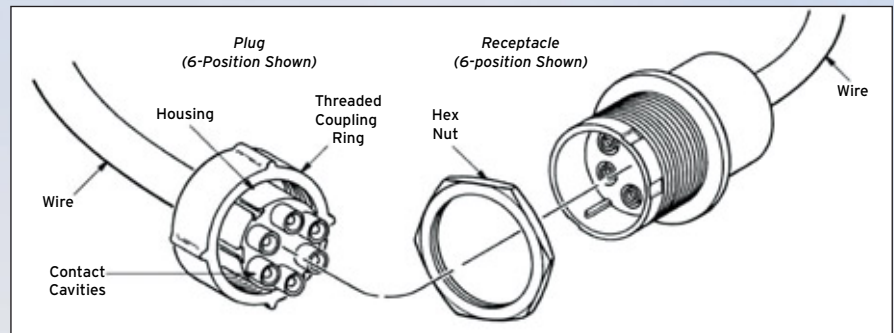

Figure 1. HV connectors protect adjacent pins from arcing by using a male insulation ring that surrounds the female part prior to electrical contact. (Courtesy TE Connectivity)

ENABLING NEW IDEAS IN HUMAN MOBILITY

From sensors, to connectors, to anything else they need, see what is going into the future of flight

- MiniMRP SYSTEM**
Standard avionics format/ easy install/compact & lightweight/ distributed architecture
- KILOVAC HIGH POWER/ VOLTAGE CONTACTORS**
1000V-1000A ready for high power full electrical solution.
- RAYCHEM POWER FEEDER CABLES**
Designed for high temperature/ engine environments
- SENSORS**
Monitor engine, flight controls, safety, environmental conditions. Designed for size & weight reduction. Power management and control.
- COPALUM TERMINATIONS**
Especially for full electrical solution requiring high electrical power
- CANBUS ASSEMBLIES**
Allow high speed connection, exchange lots of information.
- HARSH ENVIRONMENT CONNECTORS**
Small form factors, lots of inserts available accommodate fiber optic, power and signal options.

*Products are for reference only and may vary in the final vehicle design.
© 2019 TE Connectivity Corporation. All Rights Reserved. TE Connectivity, TE, TE connectivity (logo) and EVERY CONNECTION COUNTS are trademarks.

Figure 2. UAM and eVTOL projects can now utilize a wide range of high-power connectivity products for a variety of applications.



Managing Size and Weight Constraints — the need to select smaller components to trim aircraft loads.

Components employed in high-power electrical energy storage and

management in industrial applications tend to be hefty. Fortunately for aircraft, high-efficiency relays and contactors are available that can handle high voltage and amperage within a

compact footprint. For example, KILOVAC high voltage relays and contactors from TE Connectivity (TE) offer voltage ratings up to 70 kV DC and current ratings up to 1,000 Amps while providing a useful size-to-power ratio (Figure 3). Compact cables, terminations, and connectors are also available to meet demanding size, weight, and power (SWaP) requirements.

Thermal Challenges

Managing Thermal Issues — the need to dissipate heat in composite structures to create a stable electrical/electronic environment.

Dissipating heat in composite structures is difficult. Pick-up voltage (VPI) and coil resistance (RC) change as the temperature of wires and relays changes. To ensure electrical stability, the designer must determine the steady-state characteristics for the temperature and voltage combination of a DC relay's operating conditions. The same is true for AC applications, although their VPI varies less with temperature than DC relays. This evaluation ensures proper product selection.

Battery Charge Cycles — the need to enable higher energy transfer rates by optimizing heat distribution and balance.

High power charging (HPC) for DC presents a challenging electric load profile in eVTOL and UAM applications. Individual components are subjected to temperature extremes at resistance points along the HV path. For HPC system safety, a simulation can apply dynamic load profiles along the complete HV path to identify potential thermal bottlenecks. Every microhm ($\mu\Omega$) of resistance counts.

Areas to reduce resistance include cable attachment (termination technology), contact interfaces (crimps and contact types), and contact materials, as well as applying optimized high-voltage contactors and relays. Thermal sensing, thermal system protection, and thermal modeling can be used to avoid hot-spots and to design an HV path that can carry short-time peak dynamic loads.

Power-Management Challenges

Handling Power Management — the need to use high-frequency switching to enable rapid bus transfer in the event of power loss.



Figure 3. KILOVAC High Voltage Contactors



Figure 4. HARTMAN offers a variety of power switching components such as these lightweight 28 VDC contactors.



Variable frequency AC power is used for typical aircraft loads. But fixed-frequency 400 Hz AC power enables smaller and lighter transformers and motors, and faster transfer of bus power if power is lost, all of which is ideal for eVTOL applications. Used throughout the aviation and aerospace industry, HARTMAN power switching technology from TE offers 400 Hz AC contactors rated up to 500A and lightweight high-performance DC contactors, up to 1000A (Figure 4).

Hermetically sealed enclosures provide protection in severe environments. Multiple main contact configurations and auxiliary contact configurations are available. Additionally, modular power distribution units or backplane-type panels can be customized for fixed-wing aircraft and rotorcraft applications.

Using Hybrid Electromechanical and Solid-State Power Switching Technologies — the need to evaluate the advantages and disadvantages of both.

Solid-state relays (SSRs) offer silent operation, low electrical interference, functionality over a wide range of input voltages, low power consumption, and no electrical arcing. Additionally, zero-voltage crossover minimizes surge currents. Essentially an electronic circuit, an SSR employs no moving parts and resists physical shock, vibration, or changes in altitude. But as with any electronic circuit, SSRs are sensitive to ambient heat and require a heat sink. They are also vulnerable to power surges.

Electromechanical relays (EMRs) are far more tolerant of surges and overloads and can switch any AC or DC load up to their maximum rating. EMRs will operate at full load over a wide temperature range without requiring a heat sink. However, EMRs arc when contacts open and close, which may affect nearby equipment sensitive to radio frequency interference (RFI). Consequently, EMRs are suitable in applications with heavy surge currents or spike voltages that tolerate RFI. Relay manufacturers should be consulted for SSR and EMR selections that fit particular applications.

“Follow-the-Wire” to Meet High-Power Challenges

To uncover hidden factors compromising power and signal reliability, designers can employ a “follow-the-wire” methodology. Success depends on viewing interconnects holistically as part of the system rather than a last-minute afterthought. In other words, every connection counts. Industry standards groups also provide insights to solve technology problems at the subsystem and component levels.

Solution providers with extensive high-power expertise and a broad product portfolio can help designers strike the right balance between performance, cost, and time to market. Designers who need to iterate prototypes and products rapidly benefit by working with a manufacturer who can design, customize, manufacture, and implement all the components along the wire (Figure 2). A connectivity partner with broad experience can also offer innovative solutions that help eVTOL and UAM projects soar over roadblocks.

This article was written by Russ Graves, Global Aerospace Business Development Manager, TE Connectivity (Berwyn, PA). For more information, visit <http://info.hotims.com/76508-503>.

If it flies, we're probably on it.

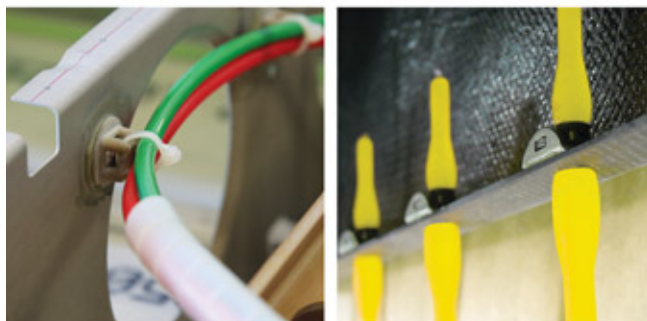

Adhesive-bonded fastening solutions:

- Require no installation holes
- Preserve structural integrity
- Install easily in tight spaces
- Eliminate crack-starting holes

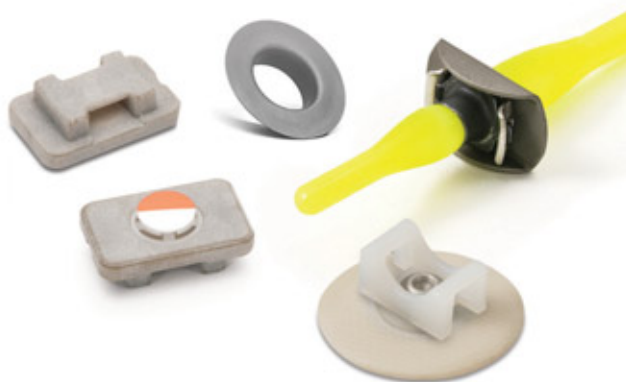

CLICK BOND®

PIONEERING > ADVANCED > SOLUTIONS

+1-775-885-8000 | WWW.CLICKBOND.COM/AD5

Redesigning the Systems Engineering Process to Speed Development of E-Propulsion Aircraft

The e-propulsion aircraft industry is a hotbed of activity and investment. However, converting these exciting concepts into viable commercial solutions presents one of the most significant challenges in the history of aviation. To streamline the development process and accelerate time to market, OEMs should consider replacing traditional, silo-based approaches to systems engineering with a model-based strategy that facilitates seamless, real-time collaboration among the entire development team.

Until the unwelcome intervention of the coronavirus pandemic, the civil aviation sector was benefiting from sustained growth in demand for global air travel. At the time of writing, it is hard to predict how quickly the industry will return to normal, and indeed what normal will look like. However, even amidst unprecedented levels of uncertainty, there can be little doubt that electric propulsion will be critical in shaping the future of aviation. Indeed, given that easing

gridlock is central to the urban air mobility offer, it could be argued that the pandemic has at least given us a glimpse of what a congestion-free, clean air future might look like.

While much progress has already been made in terms of developing electric and hybrid electric propulsion systems, significant challenges remain if we are to transform exciting concepts and prototypes into viable commercial solutions for transporting people and cargo. In overcoming these hurdles quickly and cost-effectively, OEMs can realize significant benefits by adopting a radically different approach to the system design process. By shifting from traditional, silo-based methodologies to a philosophy built around a single, system-level model and efficient real-time collaboration among the entire development team, it becomes possible to eliminate long-standing bottlenecks and inefficiencies in the delivery of complex products.

Fierce Competition Ahead

Even for those involved in the aerospace industry, the size and scale of the electric aviation

sector can come as a surprise. Recent reports indicate that there are over 200 manufacturers active in this field, backed by total investments that already run to billions of dollars. The extent of the interest is best explained by the potential rewards on offer. By 2040, it is estimated that the U.S. eVTOL (electric vertical takeoff and landing) market alone will be worth \$17.7 billion.

Inevitably, the competition between players that range from household names such as Airbus and Uber to ambitious start-ups, is going to be fierce. To come out on top, enterprises will need to resolve some seriously demanding issues. These include the ability to volume-manufacture affordable products and achieve range/payload capabilities that offer owners and operators a realistic return on investment. Safety is naturally paramount; in particular, there is a pressing need to secure wider public confidence.

Complex Projects Expose Weaknesses

Given such pressures, there are convincing arguments in favor of OEMs taking an opportunity to rethink their approach to systems engineering. To date, in the aviation sector and beyond, it is still sometimes characterized by a series of distinct boundaries: for example, between the





various stages in the product development lifecycle, and different disciplines. And even the most streamlined systems engineering processes are often undermined by problems in the transition between 1D and 3D design models.

Unfortunately, the increasingly complex nature of systems engineering has served to highlight these weaknesses. If each element of the design is handled discretely, there is obvious potential for miscommunication and misunderstanding; the wider implications of changes made in one area are not automatically reflected and registered in others. Moreover, at every stage, time is being lost. Lessons learned by one team are not readily available to others. As each new step begins, there is a manifest risk that the wheel is being reinvented.

The Benefits of a 'V-Shaped' Development Path

Figure 1 shows the widely employed V-Model approach to design. The left-hand side of the V represents the digital element of the design process. The right-hand side reflects the physical validation journey assisted by physical simulations, through to product release and manufacturing.

Virtually all aerospace OEMs have implemented this V-Model in some form or other. The starting point, at the top left of the V, is where mission requirements for the product are established. These are then translated to vehicle functional requirements using model-based systems engineering (MBSE). The process then cascades down to system, subsystem, and component design. Such a process leads to a shorter development cycle and enhanced product design.

Unfortunately, many processes that utilize the V-Model are compromised by a lack of ability to transition from 1D to 3D models. The process starts at the top left of the V with a 1D model. Ideally, it should generate increasing content for the 3D model as it progresses further down the left-hand side. To fully leverage the efficiency of the V-Model, it is essential to have a setup that enables 1D and 3D content to co-exist in the same model, and for them to be easily inter-

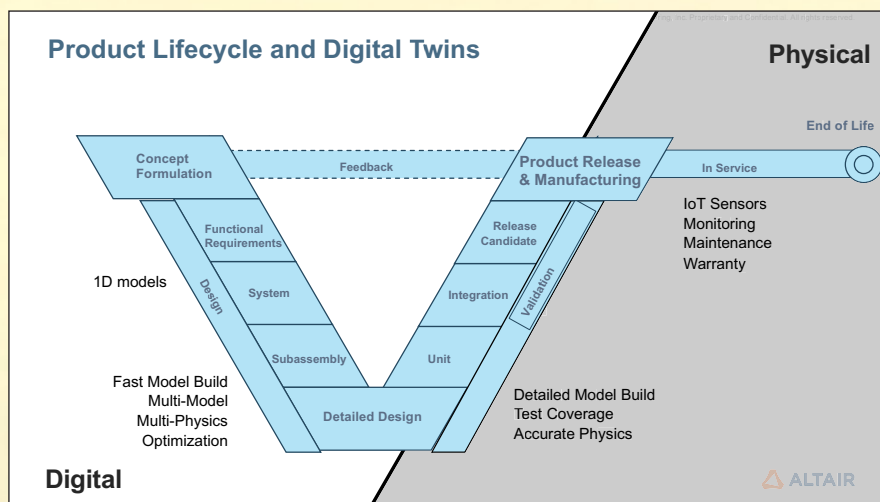

Figure 1. The V-Model approach to design

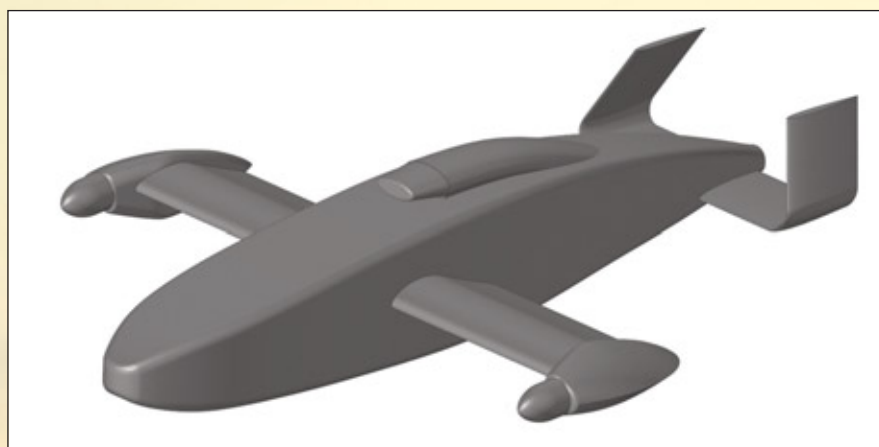

Figure 2. An existing design is often used as a starting concept to build 1D models.

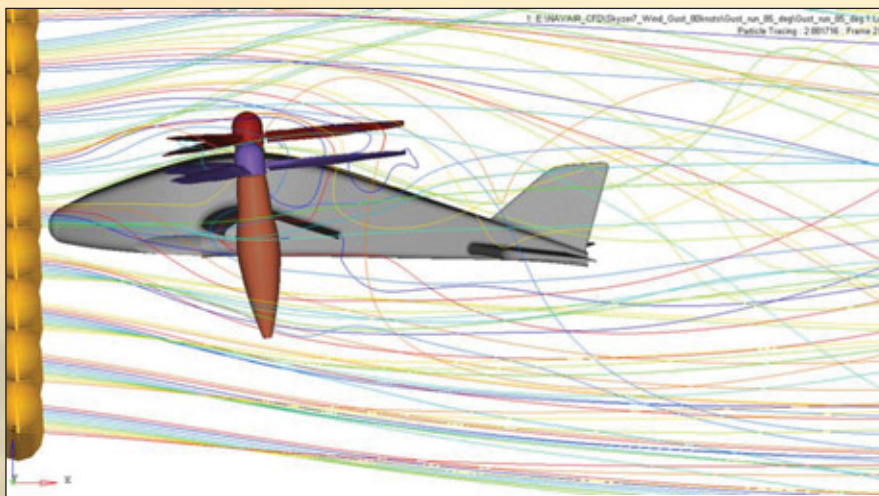

Figure 3. 3D CFD analysis was performed at a system level.

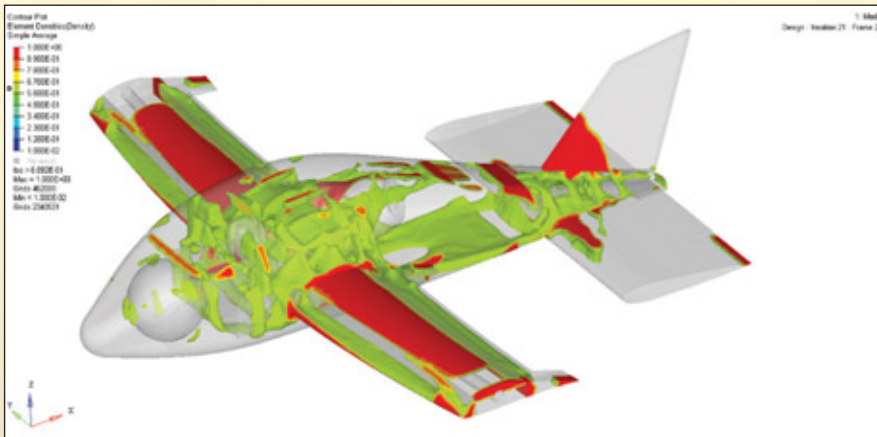

Figure 4. 3D Structural Systems Model: CFD loads were used to perform 3D structural analysis.

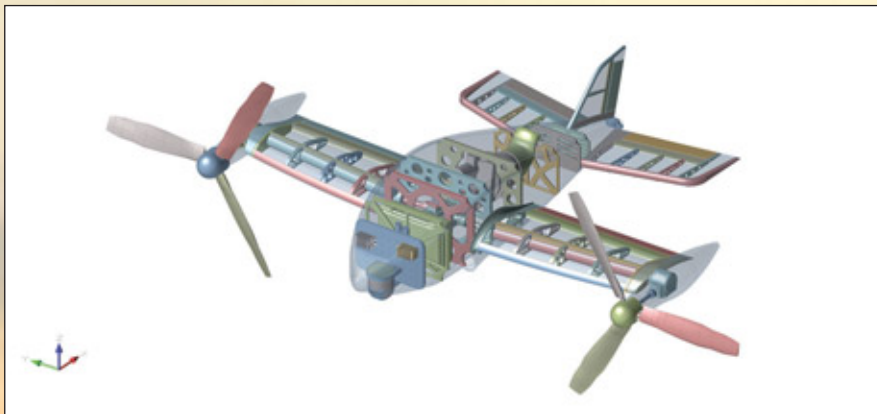

Figure 5. Results from the global analysis were cascaded down to do detailed design.

changeable. Digital models of fully validated products should also transition seamlessly to digital twins for the products deployed in service. These can then help with predictive maintenance, failure prediction, and assessment of remaining useful life throughout the lifetime of the product.

Model-Based Systems Engineering

The strategy is rooted in the principles of MBSE. In simple terms, this applies the model-based approach that is now the norm for mechanical and electrical design to systems-level engineering. So instead of a plethora of different files, documents, and discrete models, a universal, system-level model becomes the 'Authoritative Source of Truth.' With everyone involved working to this common model, it becomes far easier to ensure that collaboration, knowledge sharing,

and a seamless end-to-end development cycle become part of the project DNA.

United States Naval Air Systems Command Leads the Way

The United States Naval Air Systems Command (NAVAIR) has emerged as a pioneer in this field. Its Systems Engineering Transformation (SET) initiative aims to put in place the foundations for effective collaboration between government and industry in model-based acquisition. Altair has been selected to help implement this framework and prove it on a surrogate product. This facilitates a fully integrated multi-physics approach and effortless transition between 1D and 3D design.

Overcoming Inertia

The SET initiative serves to demonstrate that, in technical terms, all the

necessary building blocks are in place to enable a more seamless, collaborative approach to system design. In fact, at Altair it is a trend being supported right across the design engineering industry. In practice, the real barriers to wider adoption of an MBSE-type strategy are now more likely to lie in cultural and organizational inertia. People have become accustomed to doing things a certain way and are naturally reluctant to implement what appear to be dramatic changes.

In this context, it is worth stressing that a wholesale, top-down approach to change is not the only option available to OEMs. It is equally feasible to follow a more evolutionary pathway, fueled from the bottom up by design teams adopting software tools that enable cooperation at a grass roots level. That way, change becomes an ongoing, organic affair that can and should spread throughout the product development cycle.

Time To Innovate

Not long ago, concepts such as the eVTOL taxi were the stuff of science fiction. Now, making these bold ideas a commercially viable reality is a pressing imperative if the aviation industry is to meet its environmental obligations. To ensure success, leadership teams need to consider all the options available to streamline development and speed time-to-market. An MBSE-based approach, enabling real-time collaboration and seamless transition between 1D and 3D models, offers unprecedented opportunities to do just that.

In the aerospace industry, innovative thinking is invariably the key to achieving landmark breakthroughs. The electric aviation sector will be no exception. Enterprises that apply it to the system engineering process, as well as the products themselves, will be ideally positioned to secure a significant competitive advantage in what is now the industry's most important and exciting emerging market.

This article was written by Dhiren Marjadi, VP Global Aerospace Business, Altair (Troy, MI). For more information, visit <http://info.hotims.com/76508-502>.

SAE MOBILUS™ TECHNICAL RESOURCE PLATFORM

Your critical advantage to develop
the future of mobility engineering

SAE MOBILUS™ is your destination for mobility engineering resources with instant access to explore, discover, and share more than 226,000 of SAE's current and historical standards, technical papers, eBooks, magazines, and more.

THE FEATURES YOUR PEERS REQUESTED



Developed with extensive user feedback, the SAE MOBILUS™ platform features intuitive, easy search and navigation so engineers and students can focus on solving essential problems facing the mobility industry.



The customizable dashboard keeps pertinent materials accessible by allowing saved searches, personal document annotations, and custom folder creation



Dynamic redlining visually represents revision tracking for standards, eliminating a tedious manual process



Improved, intuitive site search returns focused results with content snippets so you can preview the resource before you download



COUNTER 4 reporting provides administrators with accurate, timely content usage data to enable informed subscription decisions

For more information

+1.888.875.3976

(U.S. and Canada only)

+1.724.772.4086

(Outside U.S. and Canada)

Visit saemobilus.org



Four RF Technology Trends *You Need to Know* for Satellite Communication Device Design

Over the past four decades, the sheer amount and complexity of information transmitted through satellite communication (satcom) has substantially increased. At the same time, more mission-critical applications — such as aeronautical, maritime, and military navigation — have become increasingly reliant on these communications. As a result, the RF circuit building blocks that make up satcom technology have been through many changes to accommodate the latest advancements in the industry including miniaturization, increased re-

liability, and the ability to rapidly transmit even more complex data.

This article examines four RF technology trends today that are helping satcom design engineers meet the data demands of their military and aerospace clients while also making RF components that are lighter by size, weight, and power and more cost-effective to produce (SWaP-C).

1. A Shift in Active Electronically Scanned Array Construction

Chances are, you are familiar with how television display technology has evolved and dramatically reduced the depth of

TVs in the past few decades. Likewise, the same type of evolution has occurred with the phased-array antenna technology powering today's most sophisticated radar and satcom applications.

Today, satcom applications consist of active electronically scanned arrays (AESAs) that use multiple transmit/receive modules (TRMs) to electronically steer beams independently. In the past, AESAs were quite large as they used a 3D brick configuration made up of boards placed side by side and attached using multiple connectors and cables (Figure 1, left).

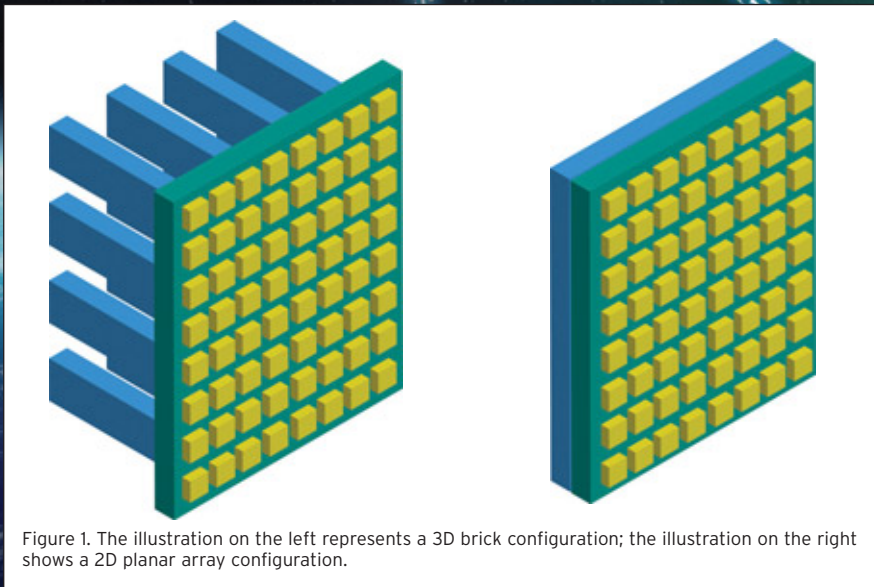

Figure 1. The illustration on the left represents a 3D brick configuration; the illustration on the right shows a 2D planar array configuration.



Instead of this bulky configuration, designs are now using 2D planar arrays that are built like a PCB using surface-mount (SM) attachment of components (Figure 1, right). A planar configuration removes the need for most connectors and cables, which not only improves SWaP-C but also increases reliability and simplifies manufacturing.

2. Operating at Increasingly High Frequencies

The whole world is moving to operate at higher frequencies and satcom applications are no exception. In response to the ever-increasing demand for communications via satellite, satcom designers are pushing through X and Ku bands to the Ka and V bands. This shift is ideal for high-throughput satellites since up to 3.5 GHz of bandwidth are available in the Ka band, which is four times more than what is available in other commonly used bands.

This increase in bandwidth is critical because, all things being equal — such as

signal-to-noise ratio, encoding, and modulation schemes — a system with four times the bandwidth can help users do one of two things: send more information in a given amount of time or send the same things in a fraction of the time. Additionally, operating at higher frequencies reduces device size because higher frequencies yield smaller wavelengths. But this does not simply mean fewer components are required or devices inherently become smaller. Instead, it actually presents new challenges as more components need to fit into smaller device form factors.

Beyond making sure everything physically fits into a circuit, other considerations need to be made to ensure optimal functionality at higher frequencies. For example, in mmWave applications, whether filters are mounted close to each antenna or at some location that feeds the antenna array, considering the size of the filter relative to the rest of the front end is important. It can become physically cumbersome to mount devices close to the antenna that are apprecia-

bly different in size to the antenna, or the antenna array itself.

3. A Shift to Build Smaller, More Efficient Radio Architectures

As we've already hinted, satcom devices, like most communication devices, are following the general trend of performing more functions with fewer components. As a result, this is creating a shift to move from traditional heterodyne architectures to a direct RF sampling approach. By doing this, components such as mixers and local oscillators (LOs) can be eliminated since a direct sampling approach digitizes an RF signal directly without turning it into an IF signal (Figure 2).

While removing components will inherently reduce size and cost, some level of filtering is still needed for direct sampling, which creates new challenges. These new filtering challenges are also much different at higher frequencies than at lower frequencies.

4. Improving SWaP-C Using a Surface Mount Device Assembly

As discussed, all satcom designers strive to improve SWaP-C.

As a result, there is a push to

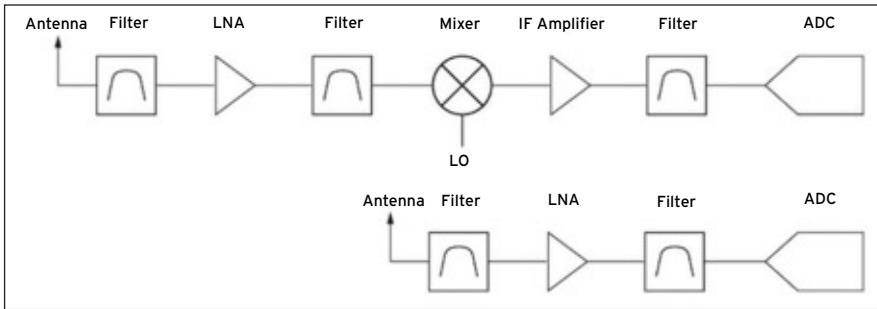

Figure 2. The block diagram on the bottom shows which components can be removed when using a direct RF sampling approach versus a heterodyne receiver.

move from traditional chip-and-wire or hybrid assembly approaches to a full surface mount device (SMD) assembly. One of the biggest cost-savings of SMD assembly is that it uses a single automated assembly line, dramatically reducing the cost of assembly versus a chip-and-wire or hybrid approach. Additionally, using a single-line SMD assembly can accelerate time to market.

Beyond cost and time savings, SMD implementations can help dramatically reduce the size of a circuit. For example, by using a microstrip filter, designers can minimize the space needed for the filter while maintaining high levels of performance in terms of bandwidth, rejection, and insertion loss.

But to achieve the benefits of SMD assembly, it is critical to select a sup-

plier who is experienced in working with SMD technology at high frequencies. While SMDs have been around a while, they were not traditionally used in the Ka band, meaning many suppliers may not be familiar with the challenges of using SMDs at high frequencies.

Designing Satcom Devices for the Future

The number of devices that need to maintain mission-critical satcom connections is rapidly growing; therefore, satcom device manufacturers are looking for ways to reduce SWaP-C while also performing device innovations to take advantage of new technologies and trends today and tomorrow.

This article was written by Tim Brauner, Product Line Manager, SLC & Thin Film, at Knowles Precision Devices, Cazenovia, NY. For more information, visit <http://info.hotims.com/76508-510>.



CMI



- ① Products: Solder Tabs (Moly Gold), Ceramic Power Planes
- ② Capabilities: Design and Assembly (inc. Wire Bonding)
- ③ Markets: Medical Device and Military Aerospace
- ④ Capacity: Prototype to Volume Manufacturing

RECEIVE NO CHARGE DESIGN PROPOSALS [compositemodules.com](http://www.compositemodules.com)

Composite Modules

High-Powered Microelectronics

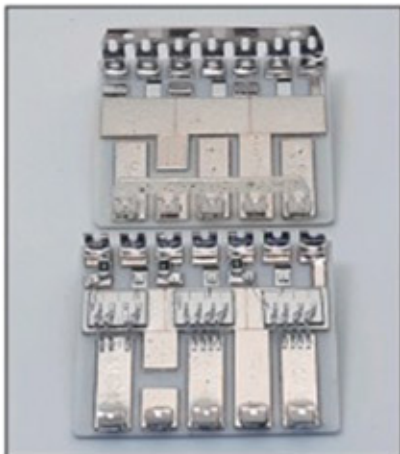
To learn more about our unique solutions and how we can serve you, get in touch with one of our experts.

(352) 799-2599 - sales@cmi-south.com - www.compositemodules.com

H.Q.: 15446 Flight Path Drive, Brooksville, FL 34604 **ISO 9001:2015 CERTIFIED**



Manufacturer Reduces Risk and Improves Quality of Military Radar Receivers



Radar receiver sensitivity is critical for electronic warfare (EW) applications. A radar receiver that is outside specifications will fail to decipher signals properly from long distances. This is not an option in military applications.

An industry-leading military radar receiver manufacturer needed to deliver radar receivers that met tough new customer specifications. To ensure a quality product, the manufacturer reviewed many aspects of its test strategy, focused on ensuring its radar receivers could meet the new specifications. Radar receiver sensitivity is critical for electronic warfare (EW) applications. A radar receiver that is outside specifications will fail to decipher signals properly from long distances. This is not an option in military applications.

Risk of False Passes

The aerospace and defense manufacturer needed to improve receiver sensitivity and the accuracy of its power level measurements in order to meet its design specifications and cost goals.

Receiver sensitivity is defined as the minimum signal level that is intelligible to the receiver or that can be demodu-

lated effectively by the receiver. Sensitivity measurement accuracy relates directly to the power level accuracy of the low-level signal. An RF signal generator connected to the radar receiver antenna input generates the source signal used to determine

receiver sensitivity. An RF signal generator with poor power level accuracy at very low power levels will cause inaccurate receiver sensitivity measurements.

If the signal generator is out-of-specification, one of two measurement errors can occur. If the signal generator delivers a higher power level than indicated, the test may result in a false pass. The false pass results in the manufacturer shipping a product it believes meets customer receiver sensitivity requirements, when in fact, the actual sensitivity is several dB higher. Correspondingly, if the signal generator delivers an under-powered signal, a false fail occurs and a “good unit” is re-worked, resulting in waste and increased cost. False pass results put this aerospace and defense company at great risk (Figure 1).

One method for reducing false pass results is to optimize test limits by using guardbanding. With measurement un-

| | | Measured Value Test Outcome | |
|----------------------------------|------|-------------------------------------------------------------------|------------------------------------------------------|
| | | PASS | FAIL |
| True Value Real World Outcome | GOOD | TRUE PASS (products in spec) | FALSE FAIL (rework and scrap costs) |
| | BAD | FALSE PASS (warranty, recall, and high liability costs) | TRUE FAIL (products out-of-spec discarded) |

Figure 1. Measurement uncertainty introduces four possible test outcomes.

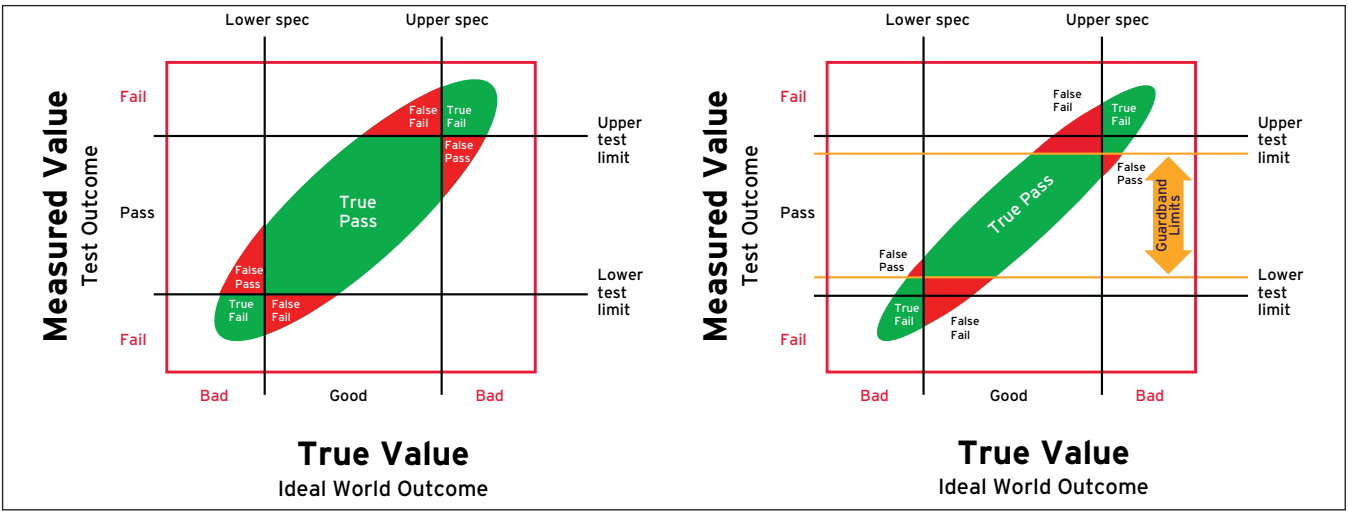

Figure 2. Reduce false pass with guardbanding.

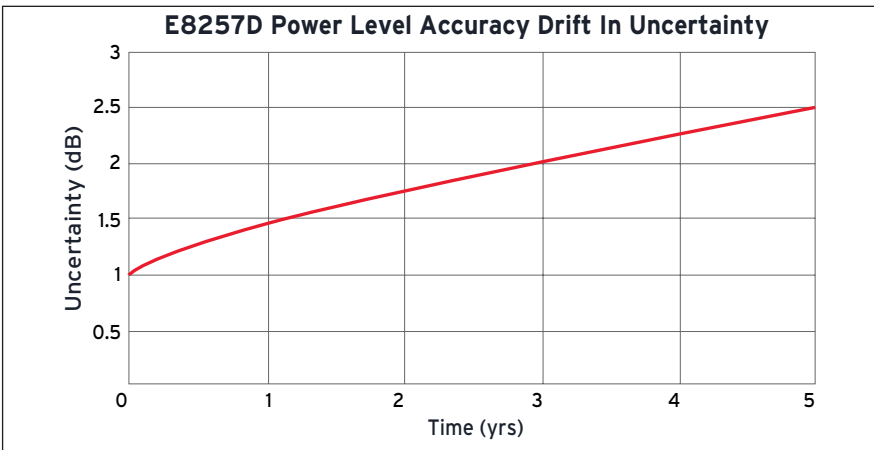

Figure 3. Drift of E8257D power level accuracy from ± 1.0 dBm to ± 2.5 dB over five years.

certainty (MU) data, guardbanded test limits can be set to reduce false passes. Figure 2 demonstrates how setting a tighter upper and lower test limit can reduce false passes.

Solution

Calibration ensures that test equipment performs to warranted specifications. Measurement uncertainty is a key contributor to false pass and false fail conditions. Reducing uncertainty starts with reviewing calibration data.

Keysight Technologies evaluated the customer’s most recent signal generator calibration report and discovered that the third-party calibration service provider only verified the power level accuracy of the signal generator at 0 dBm. The cali-

bration did not meet the requirements for the customer’s specific application because the third party did not verify the lower power levels required for radar receiver testing. The much higher MU, as shown in Figure 3, meant the company was at significant risk of out-of-specification products passing quality assurance.

Keysight demonstrated a realistic level of drift for an uncalibrated power level parameter using a statistical model for random walk and known failure rates of the E8257D PSG signal generator. Figure 3 shows that the instrument drift for the power level accuracy of an E8257D — starting from the warranted specification of ± 1.0 dBm — shifted to ± 2.5 dB after five years. This large measurement uncertainty significantly in-

creased the customer’s risk. Keysight shared a Keysight Calibration report for an E8257D at a test point at -90 dBm, proof that all factory test parameters perform within specification.

The ROI on Calibration

Keysight calculated the risk of reduced power measurement accuracy with the E8257D PSG analog signal generator. Two scenarios were modeled: one with a PSG calibrated with a very low MU and a second with a PSG that had drifted. The Keysight risk calculator used the mathematical equation for calculating risk as defined by the Joint Committee for Guides in Metrology (JCGM), a world-recognized organization formed by seven international organizations. The equation, which defines the four possible outcomes as false fail, false pass, true pass, and true fail, can be found at JCGM 106:2012 per section 9.5.¹

For modeling, the radar sensitivity for the test setup was identified at 10 GHz. A mean test value (customer specification) and guardband test limit were modeled at -88 dBm and -88.5 dBm, respectively. The MU for power level accuracy is only as good as its last calibration. After calibration, the MU for power level accuracy of an E8257A PSG analog signal generator is very small: ± 0.12 dB compared to that at ± 2.5 dB with drift.

False passes dropped from 0.05% to <0.001%, representing a dramatic reduction in risk of shipping a defective



or out-of-spec product. Keysight helped the customer estimate future cost avoidance of \$865,000 as the result of reduced risk and cost of re-work. Improving measurement accuracy of a critical measurement parameter, such as power

level accuracy, dramatically reduces risk and cost as shown in Figure 4.

Results

This radar receiver manufacturer had never seen a risk calculator based

on JCGM's mathematical definition of risk used to quantify business results in monetary terms. The before and after comparisons of lowering the measurement uncertainty of a critical power level accuracy specification convinced the manufacturer to take action.

This identified a gap in the method of calibration that low power accuracy was not measured. The discovery enabled them to reduce risk and costs by changing existing processes and provided a realistic estimate of savings.

This article was contributed by Keysight Technologies, Santa Rosa, CA. For more information, visit <http://info.hotims.com/76508-511>.

Reference

1 BIPM (Bureau International des Poids et Mesures), GUM: Guide to the Expression of Uncertainty in Measurements <https://www.bipm.org/en/publications/guides/gum.html>.

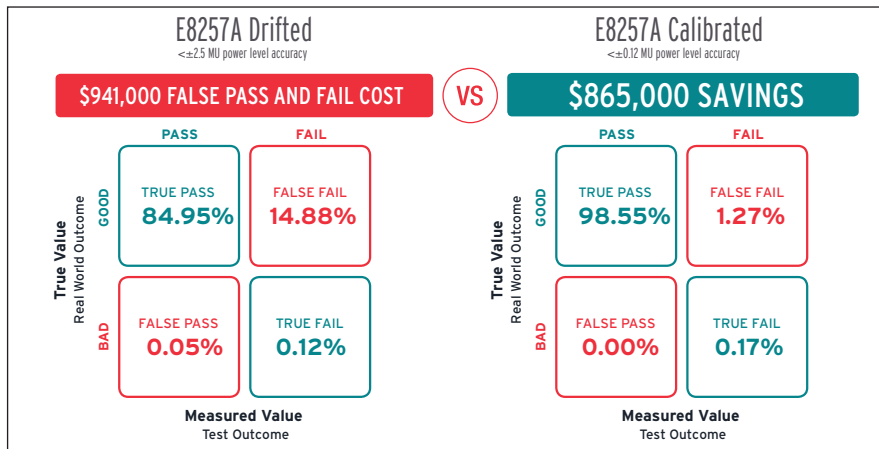

Figure 4. Four global risk outcomes when lowering the MU of a PSG Signal Generator from ≤±2.5 dB to ≤±0.12 dB.

Davinci UH-60 FULL MOTION SIMULATOR

UH-60L FULL MOTION SIMULATOR

- > INCLUDES SPARES PACKAGE / SOFTWARE
- > AVAILABLE FOR COMMERCIAL TRAINING, LEASING, MOVIE SHOOT RENTALS, AND OUTRIGHT PURCHASE
- > CONTACT: SALES@DAVINCIAIRCRAFT.COM



Instrumentation for Fabrication and Testing of High-Speed Single-Rotor and Compound-Rotor Systems

Precision data acquisition is required to generate a comprehensive set of measurements of the blade surface pressures, pitch link loads, hub loads, rotor wakes and performance of high-speed single-rotor and compound-rotor systems to support the development of next-generation rotorcraft.

Army Research Office, Research Triangle Park, North Carolina

Precision data acquisition is required to generate a comprehensive set of measurements of the blade surface pressures, pitch link loads, hub loads, rotor wakes and performance of high-speed single-rotor and compound-rotor systems to support the development of next-generation rotorcraft, such as envisioned in the Joint Multi-Role (JMR) rotorcraft program. These data are crucial to validate advanced CFD tools, as well as gain improved understanding of the fundamental physics in high advance ratio flight conditions.

The research program at the Alfred Gessow Rotorcraft Center (AGRC) is built around four interrelated thrust areas, namely: rotorcraft dynamics and aeroelasticity; aerodynamics and acoustics; flight dynamics and controls; and composite and smart structures. The research tasks are equally balanced between theoretical, computational and experimental components.

Slowed rotors – traditionally associated with autogyros and gyroplanes – have long been recognized as one potential solution for high-speed helicopters (200-300 knots). During the 1950s–70s, there were several significant programs that led to the development of high-speed helicopters with thrust and lift compounding. The key technology barriers common to all were extremely high fuel consumption due to high advancing side drag and large reverse flow, complexities associated with RPM reduction, large blade motions during RPM reduction, and unexplained but catastrophic aeroelastic instabilities of rigid rotors (Cheyenne). None of these helicopters entered regular production.

Today, the CarterCopter gyroplane is the only aircraft to have demonstrated a rotor advance ratio of 1.0 in flight in

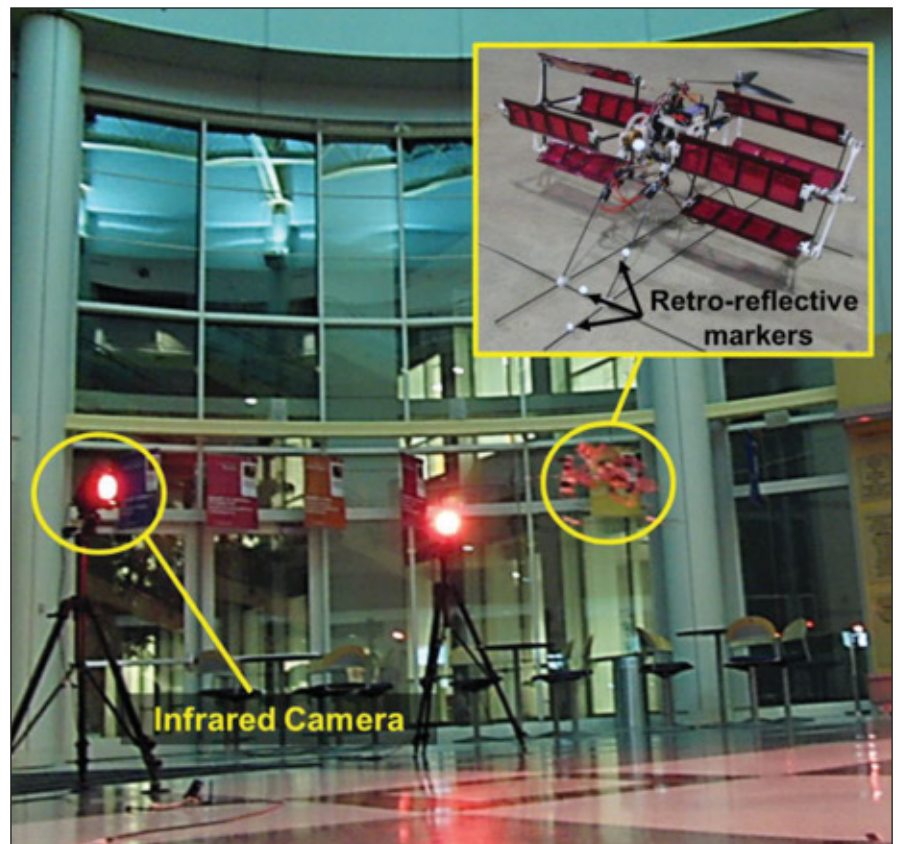

Vehicle testing using Vicon cameras. These camera systems are used for tracking flapping wing motions, blade structural deflections and MAV flight trajectory.

2005. With the advancement of materials, controls, and propulsion/drivetrain technologies (15-20% direct variation in RPM possible with same nominal specific fuel consumption and more dramatic reduction promised with variable drivetrain), slowed rotors have once again begun to emerge as a viable solution to high-speed, high-efficiency helicopters of the future (along with tilt-rotors and lift-offset coaxial compounds). The intent is the fundamental understanding of such rotors, using both analysis and experiment; at the very high-advance ratio reverse flow

conditions they are envisioned to operate in ($\mu \sim 1.5$ -2.0 and beyond).

Compared to conventional helicopters, there are only a handful of limited experimental measurements available, which are neither sufficient for fundamental understanding of their aeromechanics nor adequate for validating high-fidelity analyses that hold promise of predicting them. The only existing data set that includes performance, pressures and loads are the recent full-scale UH-60A tests – but this data is only up to $\mu = 1.0$. Model-scale tests performed recently achieve higher advance ratios (up



to $\mu=2.2$), but with simple blades (symmetric NACA0012 airfoil, untwisted) in autorotation or lower advance ratios (up to $\mu=1.0$) with realistic blades (asymmetric SC1095, twisted) and powered conditions – but all focused mostly on performance measurements and fall far short from being comprehensive.

Similarly, discrepancies in analyses – identified both in lifting-line and CFD by a recent comprehensive study have still not been systematically addressed due to the scarcity of reliable and comprehensive test data. Thus, both lack of experimental data and validated analyses can become significant technical barriers towards effective and efficient use of slowed rotors in the development of next-generation high-speed compound rotorcraft.

Coaxial compound has emerged as one of the several potential solutions

for high-speed rotorcraft - along with tilt-rotors and slowed-rotor compound – since the successful resolution of critical technology shortcomings associated with the earlier XH-59A demonstrator. These shortcomings – low efficiency/high fuel consumption, high empty weight fraction, high vibration, and challenges associated with reducing rotor speed – have now been mitigated in the X2 Technology Demonstrator by innovative use of modern technologies: advanced airfoils (double-ended at root and supercritical at tip), advanced materials (titanium to graphite-epoxy blades), active vibration control in the fixed-frame, and advanced propulsion (high efficiency pusher propeller instead of turbojet thrust).

The potential of modern refined analytical tools that have matured over the

last fifteen years – if brought to bear on this advanced coaxial rotor system, can bring about dramatic improvements in its capabilities. Some of the current technical challenges are: (1) reduced efficiency due to large reverse flow area in high-speed flight (80% of retreating side, at $\mu=0.8$, 20% rpm reduction, 250 knots), (2) high weight penalty due to active force generators in the fixed-frame to cancel the high vibration levels due to stiff blades, and (3) weight and drag penalty due to high root stresses as well as a large hub.

This work was done by Inderjit Chopra of the University of Maryland, College Park for the Army Research Office. For more information, download the Technical Support Package (free white paper) at www.aerodefensetech.com/tsp under the DAQ, Testing & Sensors category. ARL-0231

Collection, Processing, and Accuracy of Mobile Terrestrial LiDAR Survey Data in the Coastal Environment

Using terrestrial LiDAR scanners coupled with a global position system/inertial navigation system to collect elevation data along the coast can help assess the accuracy of the data.

Army Engineer Research and Development Center (ERDC), Kitty Hawk, North Carolina

Monitoring the coastline and its surroundings necessitates frequent sampling and mapping to understand the coastal processes and provide guidance for management decisions. Obstacles include continuous tide and wave influence on the morphology as well as the stability of permanent control monuments. The challenges of mapping and monitoring the coastal

terrain given the dynamic nature of the system have evolved over the years, with increased spatial and temporal sampling.

Early techniques relied on repeated, cross-shore transects using a survey transit and level rod. The electronic transit integrated with a distance meter (total station theodolite) increased the number of measurements. This was fol-

lowed by the development of the satellite-based global positioning system (GPS) and LiDAR units, capable of high point-density, three-dimensional (3D) geospatial data. Also known as laser scanning systems, LiDAR has since been coupled with position and orientation sensors, enabling mobile mapping systems (MMS) utilized on both aerial and terrestrial platforms.



The progression of the Coastal LiDAR and Radar Imaging System (CLARIS) research and development through the years 2007- 2016, left to right: Kubota UTV, Chevrolet Blazer, Prinoth track vehicle, and Ford F350 truck.



Aerial LiDAR surveys mounted on a helicopter or airplane achieve the greatest spatial coverage but are currently limited in point density when compared to the terrestrial counterpart due to the sampling speed. Aerial surveys are typically more costly, requiring more planning and logistics (e.g., fuel and environmentally favorable conditions). Static, tripod-mounted systems are less expensive and output more detailed maps but are limited in spatial coverage. Mobile terrestrial systems offer a balance between the two aforementioned techniques and are able to provide high-resolution data at lower operational costs while being rapidly deployable.

The use and accuracy of mobile terrestrial systems has been well documented in urban and coastal environments. It serves well to complement airborne LiDAR surveys by resolving more detailed structure such as building sides or foredune faces with the denser point spacing and oblique scanning angles.

Mobile, terrestrial-based LiDAR systems offer the benefits of traditional, stationary high-resolution scanning and given a high-precision navigation system, allow for large regional surveys to be conducted within hours at comparable resolution. The Coastal and

Hydraulics Laboratory, Field Research Facility (FRF), utilizes this technology to monitor beach elevation throughout the year on a seasonal scale as well as before, during, and after extratropical, subtropical, and tropical storms or hurricanes. The observational data are critical for understanding spatial and temporal trends of beach morphological evolution within the time scale of a storm event, seasons, years, and ultimately decades. The data can also be used to improve model predictions of coastal inundation and vulnerability during storms, quantify during-storm morphodynamics, monitor beach nourishment projects, and assess large-scale sediment transport and morphology evolution.

A typical mobile survey begins with initialization of the GPS/INS system to acquire stable position, attitude, and velocity data through a series of automated leveling and satellite locking routines. Once there is a signal lock on at least seven GPS satellites and the GPS Azimuth Measurement Subsystem calculates a fixed solution for the two GPS antennas' separation, the calibration procedure for GPS/INS system can begin. The vehicle operator drives around a calibration site where figure-eight turns and sudden accelerations and decelerations are

used to move and level the sensitive gyroscopes contained within the IMU. Once the attitude (roll, pitch, and yaw) accuracy values reach the desired minimum threshold based on the instrument's precision (0.02 deg for the POS-LV 220 system), the navigation system is sufficiently calibrated to begin field data collection.

LiDAR data are collected at a peak pulse repetition rate of 300 kilohertz (kHz). This results in 122,000 measurements per second with an angular resolution of 0.08° in the vertical along a narrow transect at 90° to the vehicle. As the survey progresses, the surrounding topography is scanned and a 3D point cloud is built from sequential two-dimensional linescans. A typical survey will start with the vehicle positioned parallel to the dune near the dune toe with the scanner pointed orthogonally off the passenger side and scanning offshore. The radar system is also operated while LiDAR scanning.

This work was done by Nicholas J. Spore and Katherine L. Brodie for the Army Engineer Research and Development Center (ERDC). For more information, download the Technical Support Package (free white paper) at www.aerodefensetech.com/tsp under the DAQ, Testing & Sensors category. ERDC-0010

Analysis of Broadband Metamaterial Shielding for Counter-Directed Energy Weapons

Given the importance of electronics in modern warfare, the ability to rapidly develop a counter to such weapons, such as microwave-absorbent metamaterials, will be essential to sustaining military operations.

Naval Postgraduate School, Monterey, California

Electromagnetic metamaterials are being developed and employed in a variety of applications such as sensing, imaging and optics, and signature reduction and cloaking. One application of particular interest to the military is the need for electromagnetic protection to defend battlefield electronics against high-power microwave (HPM) directed-energy weapons (DEWs)

currently under development worldwide.

HPM DEWs are a popular branch of DEW research, as microwaves propagate in the atmosphere more readily than high-energy lasers or particle beams. HPM DEWs also offer a viable non-kinetic option when collateral damage is to be avoided or a kinetic option is unavailable. However, prior research has

demonstrated that properly constructed electromagnetic metamaterials are able to prevent microwave transmission by redirecting the incident wave into either absorption or reflection. Such metamaterial shields are typically designed as composite structures consisting of patterned, conductive elements integrated with dielectric materials and arrayed in a manner that generates a de-



sired, predictable spectral response. An example of a metamaterial structure can be seen in the accompanying figure. Depending on the application, such metamaterials can become structurally complex, which makes them very difficult to model and simulate, particularly across a large frequency domain.

The purpose of this research is to present a method for retrieving equivalent medium parameters from a metamaterial structure, and then use those parameters in a homogenized finite element model in order to streamline simulation and design of macroscopic-scale objects made of metamaterials. The method proposed uses scattering data from either a simulation of a precise metamaterial structure or an experimental measurement of an actual metamaterial sample. With that data, it develops characteristic reflection and transmission spectra for the metamate-

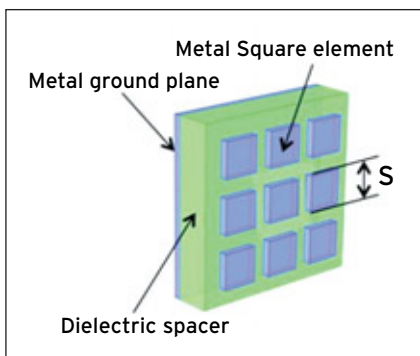

Sample Metamaterial Surface Structure

rial. The characteristic coefficients are used in a system of equations to calculate the frequency-dependent properties for an equivalent homogeneous material, that would respond to the electromagnetic incident radiation equivalently to the sampled metamaterials. The derived properties can then

be applied to a homogeneous layer in a finite element model.

The result is a simplified computer model, which closely mimics the performance of the original, structurally complex, metamaterial sample, but that can be readily modified in scale and geometry without additional computational burden. A designer would thus be able to rapidly conduct simulated scale-model testing of a metamaterial assembly without the need for multiple physical models.

Numerous systems of equations have been developed that consider electromagnetic metamaterials as homogeneous structures parameterized with frequency-dependent material properties such as permittivity and permeability. Such systems typically branch into multiple correct solutions, resulting in ambiguity when attempting to select the correct set of homogenized parameters. Methods for

NEW WAVE DV
Design & Verification

• ETHERNET • FIBRE CHANNEL • 1394b AS5643 • sFPDP • ARINC 818 • CUSTOM •
• XMC • VPX • PMC • VME • PCIe • PXle •

PROGRAMMABLE HIGH-SPEED SERIAL INTERFACES

New Wave Design and Verification specializes in customized and off-the-shelf high-speed serial interfaces. This includes hardware, interface protocols, and IP cores for high-bandwidth, ultra-low latency data distribution, processing, and networking solutions.

INTERESTED IN LEARNING MORE?

New Wave Design & Verification

Tel: +1.952.224.9201

www.newwavedv.com

info@newwavedv.com



resolving branch ambiguity usually require a material with a known permittivity and permeability at a known frequency, parameters collected from multiple thicknesses of the material, or parameters collected across multiple frequencies. In the case of this method, the initial material properties of the metamaterial were unknown, multiple thicknesses of the material were unavailable, and the simplest metamaterial analyzed was only resonant at a single frequency.

The proposed method instead addresses branch ambiguity as the ratio be-

tween the effective medium transmission path and effective wavelength in the medium. Although previously proposed systems deal in effective permittivity and permeability for a metamaterial, the finite element models employed for this research also required electrical conductivity in order to successfully predict the scattering parameters, attenuation within the simulated medium and joule heating in response to absorbed radiation. The proposed method presents an expression for estimating effective conductivity from the impedance and the

geometry of the metamaterial unit cell. Finally, prior research rarely extrapolated the performance of the retrieved parameters outside the unit cell analyzed. The proposed method retrieves parameters valid for a homogenized scale model as well as a periodic unit cell.

This work was done by Chester H. Hewitt III for the Naval Postgraduate School. For more information, download the Technical Support Package (free white paper) at www.aerodefensetech.com/tsp under the Optics, Photonics, and Lasers category. NPS-0013

Data Collection Using the MetalMapper in Dynamic Data Acquisition and Cued Modes

Safely locating, identifying and recovering buried munitions on practice and test ranges is critical to the U.S. Department of Defense's mission and its goals of safe operation, sustainability, and environmental stewardship.

Environmental Security Technology Certification Program (ESTCP), Alexandria, Virginia

The ability to safely and efficiently locate, identify, and remove buried objects on practice and test ranges is critical to the U.S. Department of Defense's mission and its goals of safe op-

eration, sustainability, and environmental stewardship.

Although several robust, advanced sensor technologies have been developed for discriminating buried objects

on ranges as targets of interest (TOIs), widespread acceptance of the technologies requires that they be demonstrated on live sites, where the impact of operating and data acquisition and



MetalMapper (MM) Configured for Cued Data Collection with Bobcat



analysis parameters can be fully evaluated. The potential benefit of the technology is to reduce the number of sub-surface investigations that are required to remove hazardous munitions and explosives of concern (MEC) in areas where subsurface clearance is required.

CB&I Federal Services LLC (CB&I) geophysicists participated in the Environmental Security Technology Certification Program (ESTCP) Demonstration of Advanced Geophysics and Classification Technologies on Munitions Response Sites at the Former Fort Ord, California (Fort Ord), and Redstone Arsenal, Alabama (RSA).

The overall objective for both sites used in the project (Fort Ord and RSA) was to demonstrate and validate Advanced Classification (AC) techniques in challenging site conditions. At Fort Ord, the primary challenge was to detect and classify munitions in areas with high subsurface metallic clutter. The primary challenge at RSA was to collect high-quality advanced sensor data in highly wooded areas that could be used for classification. Each site also had additional unique objectives that were determined in concurrence with CB&I, the U.S. Army Corps of Engineers (USACE), and project stakeholders during the project planning phase.

At Fort Ord, CB&I collected approximately five acres of dynamic MetalMapper (MM) data, which included high, medium-high, medium, and low anomaly density areas. The resulting data was used to select targets for cued measurements. Cued measurements were then used to model each target source, which resulted in the creation of a prioritized dig list. All targets were investigated for evaluation of the classification effort.

At RSA, CBI collected approximately 8.21 acres of dynamic Time-domain Electromagnetic Multi-sensor Towed Array Detection System (TEMTADS) 2x2 data in various site conditions, including high-density anomaly areas, heavily wooded areas, and areas subject to site cultural noise. The resulting data were used to select targets for cued measurements. Cued measurements were then used to model each target source, which resulted in the creation of a prioritized dig. Of these cued measurements, 221 targets were selected for subsurface investigation.

Both the MM and TEMTADS 2x2 are time domain electromagnetic (TDEM) sensors, making use of three-dimensional receiver coils, with seven and four receiver cubes, respectively. In the larger MM sensor, transverse excitation of subsurface metallic objects is accomplished explicitly with three orthogonal transmitter coils. In the smaller TEMTADS sensor, transverse excitation is accomplished implicitly via the four vertical transmitter coils at offsets from the sensor center.

In general, the primary objectives for Fort Ord were met. CB&I successfully collected high-quality dynamic and cued data using the MM and were able to meet the performance objectives for data quality. All large munitions were correctly classified as TOI. However, one of the large munitions items recovered (155 millimeter projectile) was classified as a smaller munition as defined for this project. The objective for correctly

Rod Ends and Spherical Bearings designed and manufactured to Aurora's exacting standards for quality and durability.

YOUR PARTNER MOVING FORWARD!



Registered and Certified to ISO_9001 and AS9100.

From economy commercial to aerospace approved, we've got it all!



Aurora Bearing Company
901 Aucutt Road
Montgomery IL. 60538

complete library of CAD drawings and 3D models available at:
www.aurorabearing.com

Free Info at <http://info.hotims.com/76508-837>

Del-Tron Precision, Inc. Linear Motion Specialists

CUSTOM ENGINEERED LINEAR MOTION FOR THE
AEROSPACE & DEFENSE INDUSTRY



AS9100D and ISO 9001:2015 Certified



Linear Slides
Ball & Crossed Roller

- Ball and Crossed Roller Slides manufactured right here in the USA.
- Quick deliveries!
- Standard Products or Custom Designed to meet your specific requirements.



Custom Engineered
Linear Slides

800.245.5013 • www.deltron.com



classifying the smaller munitions was met but the final dig list for the smaller munitions included a high percentage of incorrectly classified non-TOI items.

CB&I successfully collected both dynamic and cued data within heavily wooded areas encountered at Redstone. Four of the blind quality control (QC)

seeds were not classified as high confidence TOIs as per the performance objective but were included in the final dig list as "can't decide" digs. Of the 26 additional TOI items recovered, 19 of these were classified as high confidence TOIs, while the remaining 7 were classified as "can't decide" digs.

This work was done by Sandra Takata for the Environmental Security Technology Certification Program (ESTCP). For more information, download the Technical Support Package (free white paper) at www.aerodefensetech.com/tsp under the DAQ, Testing & Sensors category. ESTCP-0003

Exploring the Impact of Fuel Data Acquisition Technology on the USMC Expeditionary Energy Command and Control System

Understanding how delays in resource decision making and tactical supply chains relate to operational reach will give commanders the ability to maximize resources and improve performance.

Naval Postgraduate School, Monterey, California

The Marine Corps wants to understand how changing the volume and frequency of resupply may increase operational reach. However, fuel distribution data is still a mystery,

as the system is unable to track consumption, and human error reduces data quality.

The Marine Corps Expeditionary Energy Office manages the development

of the Expeditionary Energy Command and Control System (E2C2S), which seeks to provide commanders with the ability to maximize operational reach. Understanding syner-

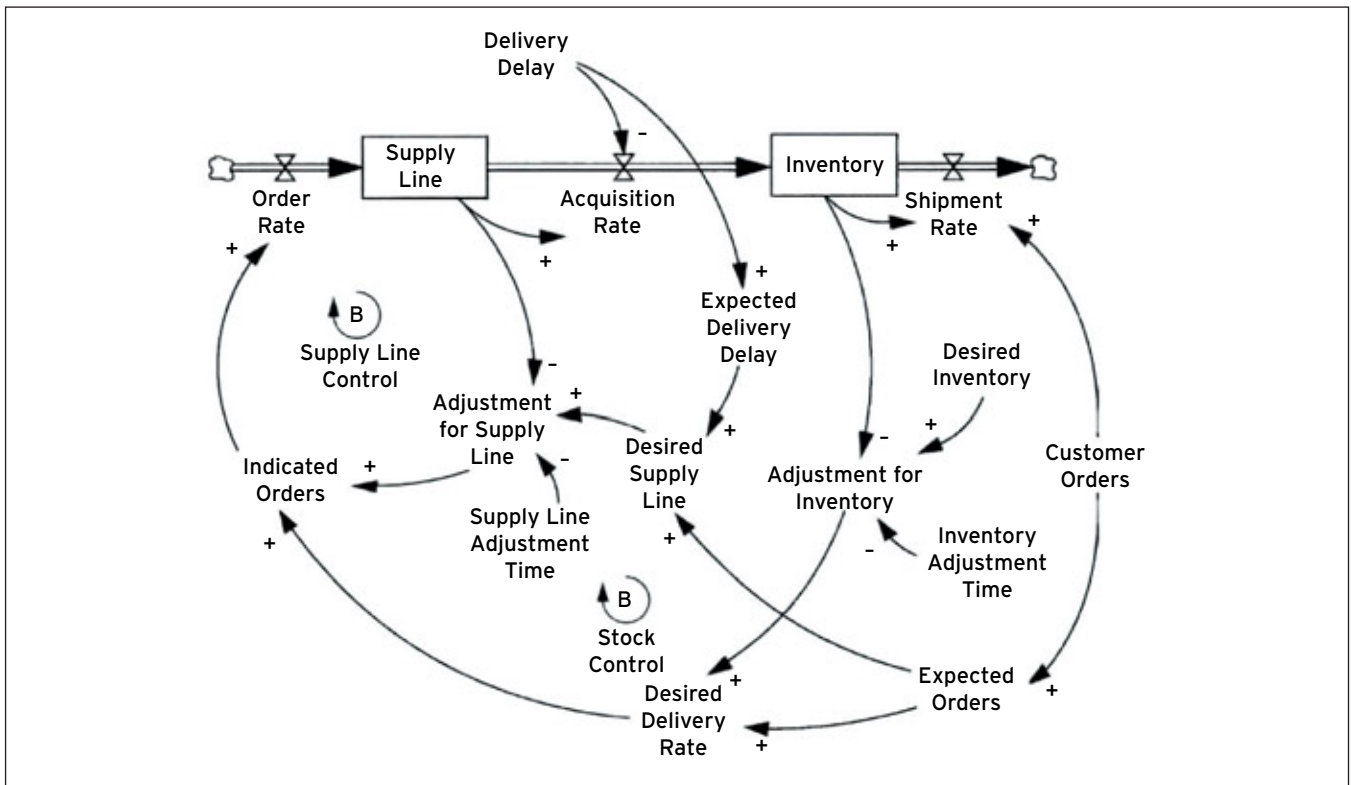

Beer Game Supply Chain Dynamics. The Beer Distribution Game, developed at MIT, provides a classic example of a supply chain made unstable by management decisions. The game shows how feedback delays cause oscillations in supply chains and how human cognition has a tendency to focus only on the immediate state of stocks.



gies gained from feedback loops in the system is important to maturing technology for effective use.

The problem is that dynamic demands create high stock requirements, which encumber supply and distribution capacity in the Marine Air Ground Task Force (MAGTF). This is a problem because the operational reach of the task force is constrained to the flow of fuel from external sources. Resupply missions create vulnerability to asymmetric threats on ground lines of communication. Marines risk casualties and material losses as they attempt to mitigate energy-based risks to front line missions.

With a lack of understanding of causal factors in fuel consumption, the exploratory phase of the study asked questions that would guide field observations and interviews. Qualitative in nature, the initial research question was open-ended. The sub-questions were more direct to fill gaps in the emergent themes in demand processing within the inductive, grounded approach.

The findings of the first phase were the input for data collection in the second phase. The quantitative analysis assumed that telematics would eliminate or reduce delays and distortion in processing demand information throughout the supply chain. The qualitative findings suggested delays are a cause of inefficiency and reduced operational reach. As such, the hypothesis states a directional relationship between telematics and operational reach.

The mixed methods study employed an exploratory sequential design. The output of the qualitative first phase was the input for the quantitative second phase. The qualitative phase collected data from participant observations, interviews, and extant literature on energy performance studies. The analysis led to an As-Is/To-Be conceptual model of the tactical fuel supply chain. The To-Be model applied system dynamics principles to reengineer the demand information processing based on a hypothetical system that would acquire data via telematics, which would make this data available to various levels of the system in near-real-time. Classic system dynamics supply chain models informed an experimental design for the quantitative phase.

Findings from the first phase attributed delays and distortion of supply and demand for dysfunction in the system. The quantitative methods applied a system dynamics modeling software, Stella, to create an experiment that would simulate the As-Is/To-Be supply chains in a controlled environment. The simulation captured the fuel stocks within a Marine Expeditionary Brigade that flowed to an artillery battery over a 30-day period.

Fully integrated telematics may provide total demand visibility, which is the ability of a supply chain activity to adjust supply line responses with near-real-time data of retail consumption. Whereas supply trains currently distribute demands registered up to 48 hours before, telematics may allow distributions to reduce the delay by a factor of two at each level of the system.

In the experimental design, an artillery battery plays the retail unit. The battery consumed fuel at the assault rate of 9,600 gallons per day. The MEB provided fuel to the battalion,

and the battalion provided fuel to the battery. Supply trains that delivered fuel 24-hours after receiving orders connected the fuel stocks. On the fifth day of the simulation, the demand of the battery fell to and remained at the sustained rate, 9,000 gallons.

For the As-Is system, the change in demand threw the battery stock into oscillation indefinitely. The oscillations amplified by the same ratio in both systems. The difference is that the To-Be design is able to get ahead of dysfunction caused by the delays. When the change in demand occurs, each supply node changes its orders by the same fractional rate the orders changed at the retail level. The To-Be system absorbed the perturbation over a week and reached 95% equilibrium. Observations of the MEB inventory showed that operational reach between the two systems oscillated, but at 30 days, the As-Is MEB stock was 7% greater than the To-Be system. The results did not support the hypothesis as formulated.

This work was done by Jeremy F. Thomas for the Naval Postgraduate School. For more information, download the Technical Support Package (free white paper) at www.aerodefensetech.com/tsp under the DAQ, Testing & Sensors category. NPS-0014

CUSTOM MOLDED RUBBER
BONDED TO METAL

OVER 70 YEARS OF SERVICE

Supplying precision custom molded rubber parts to exact customer, industrial, FDA and military specifications.

PROUDLY OWNED AND OPERATED IN THE USA
 SERVING OEM, INDUSTRIAL, LABORATORY, AND ENGINEERING DEVELOPMENT GROUPS

Hawthorne Rubber Manufacturing Corp.
 Custom Rubber Molding
 37D Fourth Avenue, Hawthorne, NJ 07506
 Tel: 973-427-3337 • Fax: 800-643-2580
www.HawthorneRubber.com



Laser Wire Additive Manufacturing System

ADDere Additive Manufacturing
Waukesha, WI
414-327-0000
www.addere.com

One of the latest parts produced by ADDere Additive Manufacturing demonstrates their unique capability of printing not only a rocket combustion chamber and nozzle, but seamlessly merging them into one full size rocket thrust chamber assembly. The scale available with the ADDere laser wire additive manufacturing system provides a viable alternative to relying on assembling a number of components with varying production processes. Further, being able to integrate components at these sizes reduces part count as well as various fastening methods that could lead to failure.

Measuring 1070 mm (42") in height and 610 mm (24.0") in diameter and completely printed out of stainless steel, the part represents a seamless transition between engine components. ADDere's control system is able to build these large shapes with metallurgical qualities approaching billet grades.

The rocket nozzle assembly took only 20 hours from start to finish. After printing, the nozzle was machined to its finished shape, having a 3 mm sidewall on the thrust chamber body with thicker walls in the combustion chamber portion.

Ultimately, according to ADDere, it's not just about making rocket engines; it's about bringing the advantages of 3D metal printing to large-scale components. These advantages include the ability to combine assemblies of parts into one component, allowing for far more advanced shapes than were previously available, as well as the freedom from relying on large



production quantities to drive prices down. This printed part is an example of where all those promises manifest.

ADDere features the ability to print longer parts up to 2 meters (6.6') long, 1 meter (3.3') wide, and 1 meter (3.3') tall, with a maximum build part weight of 1000 kg (2204 lbs). The laser power has been increased to 20 kW, allowing for higher deposition rates of up to 9 kg/hour (19.8 lbs/hour). They also specialize in hard to print metals such as: carbon steel, Inconel 625, stainless steel, D2 tool steel, 17-4 PH stainless, H13 tool steel, A2 tool steel, duplex stainless steel, and titanium.

ADDere is a division of Midwest Engineered Systems Inc. (MWES), a company that specializes in complex production systems integration. MWES has been providing custom robotic automation solutions for over 28 years.

For Free Info Visit <http://info.hotims.com/76508-460>

Hybrid Electric Drive

BAE Systems
Sterling Heights, MI
586-795-2220
www.baesystems.com/US

BAE Systems was recently awarded a \$32 million prototype agreement by the U.S. Army's Rapid Capabilities and Critical Technologies Office (RCCTO) to integrate a Hybrid Electric Drive (HED) system onto a Bradley Fighting Vehicle. The development program is part of the Army's effort to increase vehicle efficiency and boost power generation to support integration of future technologies and greater mobility for combat vehicles on the battlefield.

BAE Systems and teammate QinetiQ will use an existing Bradley Fighting Vehicle as the testbed for integrating the HED technology under the Combat Vehicle Power and Energy architecture and mobility capabilities development program. The integration work was scheduled to begin during the summer months.

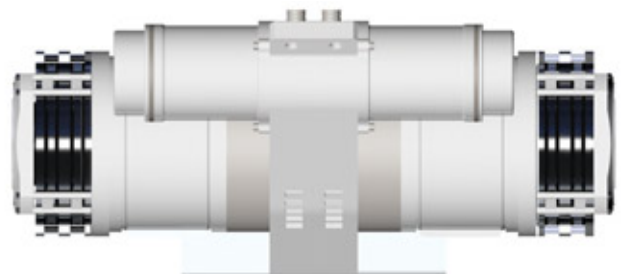

According to Scott Davis, vice president of BAE Systems' Ground Vehicles product line, "Integrating a hybrid electric drive system into combat vehicles vastly increases on-board power and provides a significant increase in mobility, lethality options, and range, all of which enable overmatching operational capabilities. A systems approach to vehicle electrification enables breakthrough capabilities in the current and future platforms warfighters need to maintain battlefield superiority."



HED systems also improve automotive performance and provide drive-by-wire mobility to support autonomy in addition to increasing power generation. With minor platform modifications, HED technology can be configured for various vehicles including the Bradley, the Armored Multi-Purpose Vehicle, the M109A7 self-propelled howitzers, and the family of Multiple Launch Rocket Systems.

QinetiQ is developing the electric cross drive transmission (Modular E-X-Drive®), a key component of an HED system for a tracked combat vehicles. The QinetiQ Modular E-X-Drive

has been tested and proven in a wide range of tracked vehicles and weight classes over the last decade. The designs have completed extensive lab and vehicle tests, including safety certifications. BAE Systems and QinetiQ have a long-standing relationship in the development of vehicle HED technologies.

The engineering activities of the HED system will primarily occur at the BAE Systems’ Sterling Heights, Michigan, and San Jose, California, facilities. Build is planned to be completed at the BAE Systems’ Sterling Heights prototype shop.

For Free Info Visit <http://info.hotims.com/76508-461>

Unmanned Ground Vehicles

FLIR Systems, Inc.
Arlington, VA
703-682-3400
www.flir.com/UIS/UGS

FLIR Systems, Inc. announced that the U.S. Marine Corps recently ordered more than 140 of the company’s Centaur™ unmanned ground vehicles (UGV), plus spares. The \$18.6 million contract is sourced through the Department of Defense Man Transportable Robotic System Increment II (MTRS Inc II) program.

Earlier this year FLIR also announced that the U.S Air Force has ordered almost 200 Centaurs through a \$23 million contract. Marine Corps Explosive Ordnance Disposal (EOD) teams will use the FLIR Centaur to assist in disarming improvised explosive devices (IEDs), unexploded ordnance, and similar hazardous tasks. Different sensors and payloads can be added to support a range of missions.

In 2017, the U.S. Army chose Endeavor Robotics, acquired a year ago by FLIR, as its medium-sized robot provider for MTRS Inc II. The company designed the all-new Centaur as its MTRS solution. FLIR is delivering robots to the Army under that multi-year program of record, which upon award was valued at more than \$150 million, including options. This latest order falls under the current ceiling.



Centaur is a medium-sized UGV that provides a standoff capability to detect, confirm, identify, and dispose of hazards. Weighing roughly 160 pounds, the open-architecture robot features an advanced EO/IR camera suite, a manipulator arm that reaches over six feet, and the ability to climb stairs. Modular payloads can be used for CBRNE detection and other missions.

For Free Info Visit <http://info.hotims.com/76508-463>

Virtual Environment System

Charles River Analytics
Cambridge, MA
617-491-3474
www.cra.com

Charles River Analytics Inc., a developer of intelligent systems solutions, recently received funding from the US Army to build the Virtual Environment Collaboration Tools for Operational Readiness (VECTOR) augmented and virtual reality (XR) system.

VECTOR uses synchronized virtual collaboration environments so distributed and dispersed mission command per-

sonnel can collaboratively plan, rehearse, and execute missions. VECTOR solves several problems faced by the US Army—mission command tasks are increasingly more difficult as global threats become more distributed, agile, and technologically advanced. Traditional and stationary command posts often suffer from degraded connectivity that limits communication and collaboration with distributed mission command personnel.

According to Arthur Wollocko, Senior Software Engineer at Charles River Analytics and Principal Investigator on the VECTOR effort, “VECTOR enables Commanders and other stakeholders to rapidly establish a virtual collaboration en-



vironment that promotes shared situational awareness and dispersed Mission Command execution, even under denied, degraded, intermittent, or limited network conditions.”

Commanders and soldiers can join VECTOR’s virtual environments through XR, mobile, and desktop applications. Once connected to a session, personnel can access a suite of collaboration tools that center on a 3D geospatial battlefield common operating picture.

The VECTOR system advances a deep understanding of virtual collaboration and data visualization in mixed reality. VECTOR augments commanders’ situational understanding, allowing them to support mission command across networks and co-locations.

This material is based upon work supported by the Army Futures Command (AFC), US Army Combat Capabilities Development Command (CCDC), Command, Control, Communications, Computers, Cyber, Intelligence, Surveillance,



and Reconnaissance (C5ISR), Command, Power and Integration (CP & I), under Contract No. W56KGU-19-C-0059.

Charles River Analytics specializes in conducting cutting-edge AI, robotics, and human-machine interface R&D to create custom solutions for organizations.

For Free Info Visit <http://info.hotims.com/76508-462>

Aircraft Protection Systems

Northrop Grumman Corporation
Falls Church, VA
1-703-280-2900
www.northropgrumman.com

The Counter-Rocket Artillery and Mortar (C-RAM) system was deployed in 2005 to address a joint urgent operational need to defend troops against rocket, artillery and mortar attacks in four primary pillars: sense, warn, intercept and respond. Countless soldiers deployed over the past decade-and-a-half have heard the jarring yet familiar “Incoming! Incoming!” siren warning in advance of an attack, while behind the scenes, the system developed and executed an intercept engagement plan. The C-RAM system is credited with saving hundreds of lives in theater, providing the precious seconds needed to take cover or lie down.

At the center of the C-RAM system is an enhanced version of the Forward Area Air Defense (FAAD) Command and Control (C2) software. FAAD C2 is the U.S. Army’s short-range air defense (SHORAD) C2 program of record. It was originally fielded to defend maneuver forces against attacks by manned fixed wing and rotary wing aircraft. The combined software, now known as FAAD/C-RAM C2, is what senses and confirms the threat, provides early warning to the specific impact area at risk, tracks the threat trajectory, and engages the in-bound threats. Northrop Grumman has been the prime contractor for FAAD/C-RAM C2 responsible for developing and fielding this capability at home and worldwide since 1986.

FAAD/C-RAM C2 is an open, modular system that allows rapid integration with available sensors, effectors and warning systems to facilitate rapid, real-time defense against short range and ma-



neuvering threats. FAAD/C-RAM C2 is integrated with more than 20 different effectors and close to 15 sensor systems, as well as a number of additional external communication systems. Besides protecting vital military bases overseas, it also provides protection to cities like Washington D.C.

Countering Unmanned Aircraft Systems (C-UAS) is at the forefront of air defense and brings new challenges to the battlefield. There is no one-size-fits-all response to address these new threats. FAAD/C-RAM C2 is the U.S. Army’s C2 solution for C-UAS, currently fielded and engaging UAS daily with multiple effector systems. FAAD/C-RAM C2 is continuing to evolve to integrate new C-UAS sensors and effectors onto the network, including electronic warfare and directed energy systems to support this growing mission.

Another example is the Army’s Mobile Low, Slow Unmanned Aerial Vehicle Integrated Defense Systems (MLIDS), a



Application Briefs

solution that has spent the last year testing at Yuma Proving Ground, Arizona. MLIDS is composed of two vehicles using FAAD/C-RAM C2 to cue, track, disrupt and destroy targets, including UAS. FAAD/C-RAM C2 also deploys and directs a one-time use attack UAS from the MLIDS vehicle that acts as a maneuverable missile. It's a UAS for the C-UAS mission.

FAAD/C-RAM C2 also recently successfully tracked, engaged and defeated a UAS during the recent IM-SHORAD Weapon Safety Performance Test at White Sands Missile Range, the first successful engagement with a Longbow Hellfire missile from a vehicle that was using an onboard sensor. Also in the works, FAAD/C-RAM C2's integration with Northrop Grumman's capability to support the full C-UAS kill chain with lethal and nonlethal systems, including Bushmaster® Chain Guns® with advanced medium caliber ammunition (Programmable Air Bursting Munitions, Proximity Fuzed and Guided) and the Mobile Acquisition Cueing and Effector (M-ACE) system.

The SHORAD mission is gaining new emphasis as the Army modernizes its capabilities to protect maneuver forces around the globe. FAAD/C-RAM C2 is the Army's directed solution for the initial maneuver solution (IM-SHORAD), as the Army continues to develop a longer-term enduring solution, Objective or OM-SHORAD. FAAD/C-RAM C2 is also the foundational command and control system for Northrop Grumman's Directed Energy M-SHORAD prototype solution and its fully integrated, mobile end-to-end offering for OM-SHORAD.

FAAD/C-RAM C2 was developed for short range air defense, and this and many other capabilities will ultimately converge into a much bigger command and control – the Integrated Air and Missile Defense Battle Command System (IBCS). This will extend the battlespace to enable both short and extended range air defense operations and provide revolutionary multi-domain defense capabilities for U.S., joint and coalition forces to address and defeat the evolving threat.

For Free Info Visit <http://info.hotims.com/76508-466>

Remotely Piloted Air Systems

General Atomics Aeronautical Systems, Inc.
San Diego, CA
858-762-6700
www.ga-asi.com

General Atomics Aeronautical Systems, Inc. (GA-ASI) has signed a contract with the UK Ministry of Defence (MoD) for the manufacture and delivery of Protector RG Mk1 Remotely Piloted Air Systems (RPAS). GA-ASI's MQ-9B SkyGuardian® is the baseline system that will become the Protector RG Mk1 when configured for the RAF. This configuration includes X-band satellite communications (SATCOM) and UK weapon systems.

The contract covers a total of 16 aircraft (an initial order of three platforms with an option for an additional 13) and seven Ground Control Stations (GCS), together with associated ground support equipment. The first system

will be delivered in 2021, though it will remain in the U.S. to be utilized in the test and evaluation program.

The plan is to deploy Protector in a variety of wide-ranging Intelligence, Surveillance, Target Acquisition and Reconnaissance (ISTAR) operations where its ability to fly consistently for up to 40 hours will offer a vastly improved ISTAR capability. Given that it is designed to fly in non-segregated, civil airspace, the Protector RPAS will also be able to support multiple civilian missions, including search and rescue and disaster response missions.

GA-ASI's development of MQ-9B began in 2014 as a company-funded program to deliver an RPA that meets the stringent STANAG-4671 UAV System Airworthiness Requirements, which provide the basis for type certification by NATO member-state military airworthiness authorities. The MQ-9B is provisioned for the GA-ASI-developed

Rugged Embedded Xeon Server & 9th Generation Intel i7 CPUs



Conductive cooling concept

engineered & manufactured in Switzerland

Features

- Up to 9th Gen Intel or Xeon D-1500 CPU
- ECC DDR4 memory
- mPCIe, PCIe & M.2 expansion
- 1 & 10 Gbit LAN ports

Highlights

- 10+ years availability, 20+ years repair
- OpenFrame up to IP67
- M-COTS solutions / SWaP-C optimized

MPL AG - Switzerland
Phone +41 56 483 34 34
info@mpl.ch
www.mpl.ch

MPL
High Tech • Made in Switzerland

Free Info at <http://info.hotims.com/76508-840>



Streamline and accelerate your multi-sourced simulation projects that are distributed across multiple organizations.

Our SystemBlend™ tool suite consists of three tools specific to each phase of the development process: design, distributed implementation, and analysis.

- ✓ SystemDesigner
- ✓ ComponentGuide
- ✓ MasterIntegrator



For a free analysis of your project, call us at 408-656-1999 or visit blenddynamics.com

Free Info at <http://info.hotims.com/76508-841>



Detect and Avoid System (DAAS) and is built for adverse weather performance with lightning protection, damage tolerance, and de-icing system. It features rapid integration of new payloads with nine hard points. The aircraft can “self-deploy” using SATCOM-enabled Automatic Takeoff and Landing, which eliminates forward-based launch-and-recovery equipment and personnel. In addition to the SkyGuardian, MQ-9B is also available as the SeaGuardian® for maritime missions.

The MQ-9B has also been selected by the Australian Defence Force and received considerable interest from civil and military customers around the world. The Government of Belgium has also approved Belgian Defense to negotiate the acquisition of MQ-9B.

General Atomics Aeronautical Systems, Inc. (GA-ASI), an affiliate of General Atomics, designs and manufactures Remotely Piloted Aircraft (RPA) systems, radars, and electro-optic and related mission systems, including the Predator® RPA series and the Lynx® Multi-mode Radar. With more than six million flight hours, GA-ASI provides long-endurance, mission-capable aircraft with integrated sensor and



data link systems required to deliver persistent flight that enables situational awareness and rapid strike. The company also produces a variety of ground control stations and sensor control/image analysis software, offers pilot training and support services, and develops meta-material antennas.

For Free Info Visit <http://info.hotims.com/76508-464>

Upcoming...

Webinars

Designing for an Electric Aircraft Future



Tuesday, October 20, 2020 at 12:00 pm U.S. EDT

Conventional aircraft configurations have three power options: pneumatic, electrical, and hydraulic. To move to a solely electric aircraft, however, requires new components such as high-speed motors, power electronics, and high-voltage cabling. This 60-minute Webinar from the editors of Tech Briefs Media and SAE International explores the new design methodologies for electric aircraft that must be considered in order to optimize aerodynamics, engines, shape, and component selection for this new propulsion architecture.

Speakers:



Russ Graves
Aerospace Business
Development Manager,
TE Connectivity



Dominik Karbowski
Technical Manager,
Intelligent Eco-Mobility,
Vehicle and Mobility Systems
Group, Argonne National
Laboratory



Dhiren Marjadi
Vice President,
Global Aerospace
Business,
Altair

Please visit www.techbriefs.com/webinar091



New Products

8.5 GHz Vector Network Analyzer

The newly announced PicoVNA 108 from Pico Technology (Cambridgeshire, UK) can see out to 8.5 GHz and down deeper to -124 dB. It provides "save on trigger" synchronization for multiple measurements, added to the convenience of integrated bias-Ts, speeds batch test and device characterizations. Offset frequency capability has also been added to the Quad RX four-receiver architecture, as well as synchronization and control of the PicoSource AS108 8 GHz agile synthesizer from within the PicoVNA 3 software, allowing RF mixer and RF/IF system characterizations.

For Free Info Visit <http://info.hotims.com/76508-498>



Fixed Load VNA Calibration Kits

Pasternack (Irvine, CA), an Infinite Electronics brand, released a new line of short-open-load-through (SOLT) calibration kits suitable for use in test and measurement, lab and RF & microwave production test applications. Pasternack's expanded line of VNA calibration kits are available in 12 versions including short circuit, open circuit and load kits (SOL) as well as short circuit, open circuit, load and thru kits (SOLT) with 2.4 mm, 2.92 mm, 3.5 mm, 7/16 DIN, 7 mm, BNC and N-Type interface options. The kits are suitable for many vector network analyzers from the industry's leading providers such as Agilent, Rohde & Schwarz, Anritsu and Copper Mountain.

For Free Info Visit <http://info.hotims.com/76508-473>



8-Port Gigabit Ethernet Switch

Techaya's MILTECH 918 military-grade, COTS 8-port gigabit Ethernet switch, available from Mil-Source (El Segundo, CA) is a rugged, small, light, power-efficient switch. With dimensions of 3.94" x 3.5" x 1.4" and weighing just 0.86 lbs. the MILTECH 918 features mechanical packaging enhancements designed for MIL-STD-810F/G/GM for airborne and ground environmental, MIL-STD 461E EMI compliance, and MIL-STD-1275 electrical & 704 electrical compliance. It is remotely programmable via web or programmatic interfaces to allow pre- and dynamic configuration.

For Free Info Visit <http://info.hotims.com/76508-499>



Wideband Recording Platform

Novator Solutions (Solentune, Sweden) announced the release of its MUNIN 1005-IF wideband recorder that ensures gapless recording of wideband IF signals from 2 MHz to 600 MHz real-time bandwidth. This, together with the pre-trigger buffer, are important in mission critical applications with GNSS, radar or telemetry signals. The configurable platform is ideal for capturing one or more RF/IF channels in real-time for DUT characterization, spectrum analysis or setting up repeatable lab tests. The updated platform supports the latest in-chassis NVME SSD drive technology as well as external hardware RAID configurations up to 96 TB (standard).

For Free Info Visit <http://info.hotims.com/76508-474>



FPGA Systems

Abaco's (Huntsville, AL) new PC821 is a high-performance, PCI Express card with advanced DSP capabilities and multiple I/O options. It supports one VITA 57.4-compliant FMC+ and one VITA 57.1 compliant HPC FMC site. Both FMC sites are closely coupled to the Xilinx® Virtex™ or Kintex™ UltraScale™ FPGA and a DDR4-2133 SDRAM SO-DIMM. The new FMC120 provides four 16-bit A/D channels up to 1 Gsps, four 16-bit D/A channels up to 1.25 Gsps and up to 2.8 Gsps sample rate with interpolation. The design is based on Texas Instruments' ADS54J60 analog-to-digital converter and Texas Instruments' DAC39J84 digital-to-analog converter.

For Free Info Visit <http://info.hotims.com/76508-470>



Digital Differential Measuring Systems

The Measuring Division of Kaman Precision Products, Inc. (Middletown, CT) announced the KD-5600 family of eddy current measurement systems, suitable for use in COTS applications such as fast steering mirrors, magnetic bearing active control, shaft vibration, image stabilization, and adaptive optics. Designed for non-contact linear position displacement sensing applications, Kaman released three configurations for tailored use. The KD-5656 (digital system), KD-5640 (analog system) and KD-5690 (FE system) are equipped with custom sensors, signal processing, analog-to-digital converter, and a custom calibration system to ensure precision and accuracy.

For Free Info Visit <http://info.hotims.com/76508-475>



Data Acquisition System

CAS DataLoggers (Chesterland, OH) in partnership with Delphint Technology, introduced a new model of the Expert Transient data acquisition system, the 4 channel ET-4. Designed for data acquisition and fault diagnostics, a key feature of the Expert Transient family is the ability to synchronously acquire multiple analog channels at sample rates up to 50 kHz. In addition to the 4 analog input channels, the ET-4 has 4 digital inputs to capture pulses, discrete inputs or digital triggers. An extension bus allows the system to be extended to over 100 analog or digital inputs with high-speed synchronization protocols.

For Free Info Visit <http://info.hotims.com/76508-471>



Mobile Surface Measurement System

Mahr Inc. (Providence, RI) introduced the new MarSurf M 310 mobile surface measurement system. The all-new M 310 features a large, illuminated, rotatable 4.3" high-resolution touch screen built right into the unit, as well as automatic creation of measuring reports in PDF format, integration of a barcode or data matrix scanner, and the ability to print reports on letter size paper. Integrated memory enables more than 500,000 measurement results to be stored, 1,500 PDF protocols and an optional Micro SD card slot allows additional memory to be added to increase that up to 320 times — or 160 million results.

For Free Info Visit <http://info.hotims.com/76508-476>



PXI Multifunction Instrument

Marvin Test Solutions, Inc. (Irvine, CA) announced the release of the new GX3722 Series Multifunction Analog and Digital I/O Instrument. Analog measurement capabilities include four time-interval channels, each rated at 10 MHz, with channels supporting both 50Ω and 75Ω input impedance. Two digitizer channels, each with a maximum sampling rate of 10 MS/s, include programmable input impedance and sampling rates with a 24 Vpp input range. Two channels of multifunction waveform generation deliver sine, triangle, sawtooth, square, and arbitrary signals up to 10 MHz, while four channels of dedicated square wave generation further complement the source capabilities of this card.

For Free Info Visit <http://info.hotims.com/76508-477>



OpenVPX Backplanes

Pixus Technologies (Waterloo, Ontario) now offers 3U and 6U OpenVPX power and ground backplanes in several configurations. The 1-slot backplanes come in VITA 65 (VPX only), VITA 66.4 (optical), and VITA 67.3 (RF) formats. The optical and RF versions feature a cutout for optional insertion of the aperture housing and contacts.

For Free Info Visit <http://info.hotims.com/76508-479>





Buffing Wheels

Saint-Gobain Abrasives (Worcester, MA) introduced its new Norton FAB (Fixed Abrasive Buff) buffing wheels featuring a patent pending design that incorporates abrasive grains into the buffing wheel, resulting in excellent single digit Ra values ranging from 1 to 5 Ra. The new Norton FAB wheels have a premium silicon carbide abrasive uniformly dispersed and applied to both sides of the cloth, resulting in more consistent buffing performance on hard alloys as well as soft metals such as aluminum and brass. Norton FAB Wheels are available in outer diameters from 5" to 22", in 12 or 16-ply (number of cloth layers of buff), 2 or 4 pack (waviness of the buff face) and various ID hole designs.



For Free Info Visit <http://info.hotims.com/76508-478>



Integrated Dual RF Transceiver

Richardson RFPD (Geneva, IL) announced a new dual narrow/wideband RF transceiver from Analog Devices, Inc. The ADRV9002 is an RF transceiver that has dual-channel transmitters, dual-channel receivers, integrated synthesizers, and digital signal processing functions. The ADRV9002 operates from 30 MHz to 6000 MHz and covers the UHF, VHF, licensed and unlicensed cellular bands, and industrial, scientific, and medical (ISM) bands. The IC can support both narrowband (12 kHz) and wideband standards up to 40 MHz bandwidth on both receive and transmit.

For Free Info Visit <http://info.hotims.com/76508-480>

Pulsed Amplifier

Empower's (Inglewood, CA) Model 2225 is a long duty cycle pulsed amplifier operating from 5.2 to 5.9 GHz and represents new technologically advanced liquid cooled and scalable architecture. The amplifier system layout consists of a system controller in 3U and up to 16 hot-swappable 2U amplifier drawers with each amplifier drawer containing an integrated power supply in its 2U chassis. This arrangement eliminates the risk of an RF section or single power supply failure taking the entire amplifier offline.



For Free Info Visit <http://info.hotims.com/76508-492>



ARM Programming Software

The newly released SEGGER (Monheim am Rhein, Germany) Embedded Studio V5 for Arm processors comes with the company's Compiler, Linker, Runtime and Floating-Point libraries included. All components are designed from the ground up for use in embedded systems and work seamlessly to help generate extremely small programs. A program which blinks an LED on a typical Cortex-M microcontroller unit can be written in C or C++, with a total size of less than 100 bytes. Terminal output (printf) can be done in real time using RTT, SWO or semi-hosting with host-side formatting, keeping even the standard 'Hello World' program to no more than a few hundred bytes.

For Free Info Visit <http://info.hotims.com/76508-482>

Flight Control Solutions

UAV Navigation (Sebastián de los Reyes, Spain) announced that its flight control solutions for Remotely Piloted Air Systems/Unmanned Aerial Vehicles (RPAS/UAVs) are compatible with the Trimble® UAS1, a high-precision Global Navigation Satellite System (GNSS) receiver. The core benefits of Trimble's GNSS solution include centimeter-level precision and easy integration. In addition, the GNSS receiver can provide Real-Time Kinematic (RTK) positioning using a base station. The Trimble UAS1 receiver includes a 336-channel high-precision GNSS engine. It tracks L1/L2 frequencies from the GPS, GLONASS, Galileo and BeiDou constellations.



For Free Info Visit <http://info.hotims.com/76508-497>

Sampling Oscilloscope

Anritsu Company (Allen, TX) introduced a Clock Recovery Unit (CRU) option for its BERTWave™ MP2110A that supports trigger clock generation from a 53-Gbaud PAM4 optical signal. When combined with existing oscilloscope functionality, the new 53-Gbaud CRU allows the MP2110A to serve as an all-in-one solution that can evaluate various PAM4 optical modules during development and manufacturing. Anritsu developed the 53-Gbaud CRU for the BERTWave MP2110A sampling oscilloscope to address expanding PAM4 signal analysis requirements due to the emergence of 100G to 400G fast, large-capacity networks.



For Free Info Visit <http://info.hotims.com/76508-489>



Mechanical Joining Tools

Monaghan Tooling Group (Dayton, OH) has introduced their Mechanical Joining Tools to join tubing to flanges and fittings, creating secure, leak-proof joints that withstand up to 20,000 pounds of hydrostatic pressure. Superior to welded, brazed or crimped joints, mechanically joined parts will not leak, pull apart, or loosen due to pressure, vibration, or temperature changes. This proven method allows joints to be rolled to a torque or diameter spec. Virtually any annealed or ductile product can be mechanically joined, including mild steel, stainless steel, aluminum, titanium, copper, cupronickel, Inconel and more.

For Free Info Visit <http://info.hotims.com/76508-485>

Intrinsically Safe Weighing Instruments

Hardy Process Solutions (San Diego, CA) released two new UL-rated intrinsically safe weighing indicators designed for hazardous areas. The HI 8200IS is an advanced indicator with checkweighing features, while the HI 8100IS is a basic five-button indicator designed for use in hazardous locations. Both instruments feature two available power options: AC line power for permanent installation in the hazardous area; or high-performance external rechargeable battery packs that are easy to switch out for recharging in the safe area.



For Free Info Visit <http://info.hotims.com/76508-486>

SMARC 2.1 Carrier Board

The new size-optimized conga-SMC1/SMARC-x86 SMARC 2.1 carrier board in 3.5-inch form factor from congatec (San Diego, CA) is scalable across the entire Intel Apollo Lake processor range, from Intel Atom (E3950, E3940 and E3930) to Celeron (N3350) and Pentium (N4200) processors. Measuring just 146 x 102 mm, the conga-SMC1/SMARC-x86 offers dual GbE, 5x USB and USB hub support as well as SATA 3 for external hard drives or SSDs. For custom expansions, the board offers a mini-PCIe slot as well as an M.2 Type E E2230 slot with I2S, PCIe and USB, and an M.2 Type B B2242/2280 with 2x PCIe and 1x USB.



For Free Info Visit <http://info.hotims.com/76508-487>

MCUs for Industrial Automation

Renesas Electronics Corporation (Tokyo, Japan) recently announced the RX72N Group and RX66N Group of 32-bit microcontrollers (MCUs) combining equipment control and networking function on a single chip. Built around the Renesas proprietary RXv3 CPU core, the RX72N features a maximum operating frequency of 240 megahertz (MHz) and two Ethernet channels, and the RX66N features a maximum operating frequency of 120 MHz and one Ethernet channel. The new RX72N and RX66N devices offer up to 4 megabytes (MB) of on-chip flash memory that perform read operations at a frequency of 120 MHz, as well as 1 MB of on-chip SRAM.



For Free Info Visit <http://info.hotims.com/76508-491>

New Products

**Ultrasonic Technology**

Loop Technology's FibreCut 6-axis robot system draws upon Telsonic's (Dorset, UK) ultrasonic technology, to provide a solution capable of making precision cuts on 3-dimensional composite preforms. Telsonic's ultrasonic solution is based upon their MAG2012S generator (20 kHz variant) and SE2012 converter. Cutting knives are designed to be readily interchangeable to suit different materials or depths-of-cut.

Typical cutting performance on dry materials, and using a 70-mm blade, is up to 200 mm per second, with up to 70 mm cutting depth in a single pass. For prepreg material, the typical values for a 35 mm blade range from 10 to 15 mm per second with a 5 mm depth of cut per pass.

For Free Info Visit <http://info.hotims.com/76508-483>

Balancing System

DELO (Sudbury, MA) has collaborated with Präzisionsmaschinenbau Bobertag (PMB) to create a new additive balancing technology for rotating parts found in electric motors, fans, pumps and turbines. PMB uses a balancing compound from DELO to correct any unbalances identified in a highly accurate measurement. The material, which is dispensed quickly and precisely in minimum quantities using the DELO-DOT D4 microdispensing valve, is then cured within seconds through irradiation with DELO's DELOLUX UV lamps, reducing noises and increasing the lifetime of a product. With minimum possible correction accuracies of 0.1 mg, residual unbalances of 1 mg*mm, as found in the optical industry, can be achieved.

For Free Info Visit <http://info.hotims.com/76508-490>

**Non-Destructive Testing Tool**

HEBI Robotics (Pittsburgh, PA), a spin-off of Carnegie Mellon University's renowned Robotics Institute, is expanding its robotics offerings with MAPS, a new smart robotic tool for industrial inspection. MAPS (Modular Absolute Positioning System) makes it possible to perform fully encoded NDT (non-destructive testing) inspections on any complex surface, faster and more reliably than conventional methods. MAPS is a lightweight, portable, passive arm that continuously measures the full absolute position and orientation of a probe as it is moved along any surface. Thickness data from the probe is combined with positional data from MAPS to create fully encoded scans of complex surfaces like pipe elbows, tees, reducers and nozzles.

For Free Info Visit <http://info.hotims.com/76508-472>

3U VPX CPU/GPGPU

Concurrent Technologies (Colchester, UK) announced a new single slot 3U VPX CPU and GPGPU for air and conduction-cooled applications in partnership with EIZO Rugged Solutions. BA 1TR/m03 is a single slot board, based on the Concurrent Technologies TR E8x/msd CPU board, fitted with an EIZO's Condor NVP2000 XMC module. Concurrent Technologies TR E8x/msd CPU is normally fitted with a 6-core Intel® Xeon® E-2276ME processor running at 2.8 GHz with up to 32 GB of soldered down DDR4 memory. The default variant of the Condor NVP2000 GPGPU features H.265/H.264 hardware encode/decode capability and comes equipped with DisplayPort++ and DVI video outputs.

For Free Info Visit <http://info.hotims.com/76508-495>

**D/A Converter XMC**

Pentek, Inc., (Upper Saddle River, NJ) announced its most recent addition to the Jade® Architecture family, the Jade® Model 71871, a four-channel 1.25 GHz D/A converter XMC for RF and IF waveform generation. The Model 71871 combines two Texas Instruments DAC3484s to deliver four independent analog outputs each through its own digital upconverter and 16-bit D/A with sampling rates to 1.25 GHz. A Xilinx Kintex Ultrascale FPGA contains factory-installed functions that include a sophisticated D/A waveform generation IP module. Complex output waveforms, each with bandwidths up to 250 MHz, can be independently translated to programmable IF frequencies.

For Free Info Visit <http://info.hotims.com/76508-496>

Spectrum Analyzer

Saelig Company, Inc. (Fairport, NY) has introduced the SIGLENT SSA3000X-R Real-Time Spectrum Analyzers (RTSA) for complex RF spectrum and signal analysis. With a capability of 40 MHz analysis bandwidth and 7.2 s 100% probability of intercept (POI), the analyzers can provide multi-dimensional data displays, advanced triggering, and RF data capturing. The SSA3050X-R model has a frequency range of 9 kHz to 5.0 GHz, while the SSA3075X-R has a range of 9 kHz to 7.5 GHz. The built-in tracking generators operate from 100 kHz to 5.0 GHz and 100 kHz to 7.5 GHz respectively, and a preamplifier is included.

For Free Info Visit <http://info.hotims.com/76508-494>

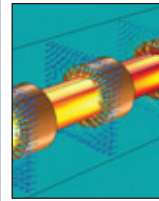
**MULTIPHYSICS MODELING AND SIMULATION APPLICATIONS**

COMSOL Multiphysics® is a software environment for creating physics-based models and simulation applications. Add-on products provide tools for electromagnetics, structural, acoustics, fluid flow, heat transfer, and chemical simulations. Interfacing products offer a unified workflow with all major technical computing and CAD tools. COMSOL Compiler™ and COMSOL Server™ are used for deploying simulation applications to colleagues and customers. <https://www.comsol.com/products>

COMSOL, Inc.

Free Info at <http://info.hotims.com/76508-842>

TOUGHENED EPOXY RESISTS THERMAL CYCLING

Master Bond Supreme 17HT is a one component epoxy for bonding and sealing applications featuring an unlimited working life at room temperature. This thermally stable formulation has a high glass transition temperature of 410°F (210°C) and retains its bond strength at elevated temperatures. It is ideal for bonding dissimilar substrates. <https://www.masterbond.com/tcls/supreme-17ht>

Master Bond

Free Info at <http://info.hotims.com/76508-843>

A WORLD OF FIBER OPTIC SOLUTIONS

- T1/E1 & T3/E3 Modems, WAN
- RS-232/422/485 Modems and Multiplexers
- Profibus-DP, Modbus
- Ethernet LANs
- Video/Audio/Hubs/Repeaters
- USB Modem and Hub
- Highly shielded Ethernet, USB (Tempest Case)
- ISO-9001

<http://www.sitech-bitdriver.com>

S.I. Tech

Free Info at <http://info.hotims.com/76508-844>

ULTRA-RELIABLE, PRECISION INERTIAL SENSING

Silicon Sensing's DMU30 - the high integrity inertial measurement unit for attitude determination, platform stabilisation and navigation on both manned and unmanned aerospace and space platforms. This formidable, non-ITAR IMU is small, lightweight and calibrated to deliver sustained performance across the full rated temperature range. Silicon Sensing MEMS gyroscopes, accelerometers and inertial systems deliver precise, rugged, ultra-reliable inertial sensing. <https://www.siliconsensing.com/products/inertial-modules-systems/dmu30/>

Silicon Sensing Systems

Free Info at <http://info.hotims.com/76508-845>



AEROSPACE & DEFENSE TECHNOLOGY

Ad Index

| | |
|--------------------------------------------|---------------------------------|
| Publisher | Joseph T. Pramberger |
| Editorial Director | Linda L. Bell |
| Editor | Bruce A. Bennett |
| Digital Editorial Manager | Billy Hurley |
| Associate Editor | Edward Brown |
| Content Strategist, Audience Development | Kendra Smith |
| Production Manager | Adam Santiago |
| Production Coordinator | James Rodriguez |
| Creative Director | Lois Erlacher |
| Graphic Designer | Annette Murphy |
| Marketing Director | Kaitlyn Sommer |
| Marketing Coordinator | Sam Mills |
| Marketing Coordinator | Aimee Carmer |
| Audience Development Director | Christine Oldenbrook |
| Audience Development Coordinator | Stacey Nelson |
| Audience Development/Circulation Assistant | Erykah Davis |
| Subscription Changes/Cancellations | ADT@OMEDA.com 1-866-351-1125 |

TECH BRIEFS MEDIA GROUP, AN SAE INTERNATIONAL COMPANY
261 Fifth Avenue, Suite 1901, New York, NY 10016
(212) 490-3999 FAX (646) 829-0800

| | |
|------------------------------------|----------------------|
| Chief Executive Officer | Domenic A. Mucchetti |
| Executive Vice-President | Luke Schnirring |
| Technology Director | Oliver Rockwell |
| Digital Development Manager | Peter Bonavita |
| Digital Production Manager | Howard Ng |
| Digital Media Associate | Md Jaliluzzaman |
| Digital Media Assistant | Rowena Pagarigan |
| Digital Production Associate | Andrew Greenberg |
| Digital Production Associate | Symba Wong |
| Credit & Collection Manager | Stacie Pointek |
| Credit/Collection | Felecia Lahey |
| Accounting/Human Resources Manager | Sylvia Bonilla |
| A/R Credit & Collection Manager | Crystal Ortiz |
| Office Manager | Alfredo Vasquez |

ADVERTISING ACCOUNT EXECUTIVES

| | |
|----------------------------------------------------|-------------------------------------------------------------------------------------------------------------------------------------------------------------------------------------------------------------------|
| MA, NH, ME, VT, RI, Eastern Canada | Ed Marecki (401) 351-0274 |
| CT | Stan Greenfield (203) 938-2418 |
| NJ, PA, DE | John Murray (973) 409-4685 |
| Southeast, TX | Ray Tompkins (281) 313-1004 |
| NY, OH | Ryan Beckman (973) 409-4687 |
| MI, IN, WI | Chris Kennedy (847) 498-4520 ext. 3008 |
| MN, ND, SD, IL, KY, MO, KS, IA, NE, Central Canada | Bob Casey (847) 223-5225 |
| Northwest, N. Calif., Western Canada | Twyla Sulesky (408) 779-0005 |
| S. Calif., AZ, NM, Rocky Mountain States | Tim Powers (908) 892-2838 |
| Europe – Central & Eastern | Sven Anacker 49-202-27169-11 Joseph Heeg 49-621-841-5702 |
| Europe – Western | Chris Shaw 44-1270-52130 |
| Integrated Media Consultants | Patrick Harvey (973) 409-4686 Scott Williams (973) 545-2464 Rick Rosenberg (973) 545-2565 Todd Holtz (973) 545-2566 Christian DeLalla (973) 841-6035 Casey Hanson (973) 841-6040 |
| Reprints | Jill Kaletha (219) 878-6068 |

| Advertiser | Page | Web Link |
|--------------------------------|-------------|--------------------------|
| AGM Container Controls Inc. | 2 | agmcontainer.com |
| AirBorn, Inc. | 13 | www.airborn.com |
| Applied Avionics, Inc. | 4 | www.appliedavionics.com |
| Aurora Bearing Co. | 33 | www.aurorabearing.com |
| Blend Dynamics | 39 | blenddynamics.com |
| Click Bond, Inc. | 17 | www.clickbond.com |
| Composite Motors Inc. | 24 | www.compositemodules.com |
| COMSOL, Inc. | 43, Cover 4 | comsol.com |
| Crystal Group, Inc. | Cover 2 | crystalrugged.com |
| DaVinci Aircraft, Inc. | 27 | davinci-aircraft.com |
| Del-Tron Precision, Inc. | 33 | www.deltron.com |
| Hawthorne Rubber Mfg. Corp. | 35 | www.hawthornrubber.com |
| Infinite Electronics/Milestek | 9 | milestek.com |
| Master Bond Inc. | 43 | www.masterbond.com |
| Minco Products, Inc. | 5 | minco.com |
| MPL | 39 | www.mpl.ch |
| New England Wire Technologies | 1 | www.newenglandwire.com |
| New Wave Design & Verification | 31 | www.newwavedv.com |
| Renishaw Inc. | 3 | www.renishaw.com |
| S.I. Tech | 43 | www.sitech-bitdriver.com |
| SAE Mobilus | 21 | saemobilus.org |
| Silicon Sensing Systems Ltd. | 43 | www.siliconsensing.com |
| The Lee Company | Cover 3 | www.theleeco.com |

Aerospace & Defense Technology, ISSN 2472-2081, USPS 018-120. Periodicals postage paid at New York, NY and at additional mailing offices. Copyright © 2020 in U.S. is published in February, April, May, June, August, September, October, and December (8 issues) by Tech Briefs Media Group, an SAE International Company, 261 Fifth Avenue, Suite 1901, New York, NY 10016. The copyright information does not include the (U.S. rights to) individual tech briefs that are supplied by NASA. Editorial, sales, production, and circulation offices at 261 Fifth Avenue, Suite 1901, New York, NY 10016. Subscription is free to qualified subscribers and subscriptions for non-qualified subscribers in the U.S. and Puerto Rico, \$100.00 for 1 year. Digital Edition: \$24.00 for 1 year. Single copies: \$30.00. Foreign subscriptions, one-year U.S. Funds: \$195.00. Remit by check, draft, postal, express orders or VISA, MasterCard, and American Express. Other remittances at sender's risk. Address all communications for subscriptions or circulation to NASA Tech Briefs, 261 Fifth Avenue, Suite 1901, New York, NY 10016. Periodicals postage paid at New York, NY and at additional mailing offices.

POSTMASTER: Send address changes and cancellations to Aerospace & Defense Technology, P.O. Box 3525, Northbrook, IL 60062.

October 2020, Volume 5, Number 7

WHEN IT COMES TO PERFORMANCE, WE'RE YOUR WINGMAN.

PEACE OF MIND, SINCE 1948.

Count on The Lee Company for relentless support and unsurpassed reliability. That's been our approach for over 70 years, which has placed our field-proven Microhydraulic fluid control components on board every military and commercial aircraft flying today. So, whether you need a standard or custom-engineered solution, choose The Lee Company and relax. We've got your back.



Your Microhydraulics Flight Manual. The Lee *Technical Hydraulic Handbook* has, for decades, served as the industry-standard engineering reference for hydraulic components. Request your free copy today at www.theleeco.com/new-hydraulic-handbook

The Lee Company 860-399-6281 • www.theleeco.com/aerospace
WESTBROOK • LONDON • PARIS • FRANKFURT • MILAN • STOCKHOLM

Free Info at <http://info.hotims.com/76508-846>

Develop better products – faster.

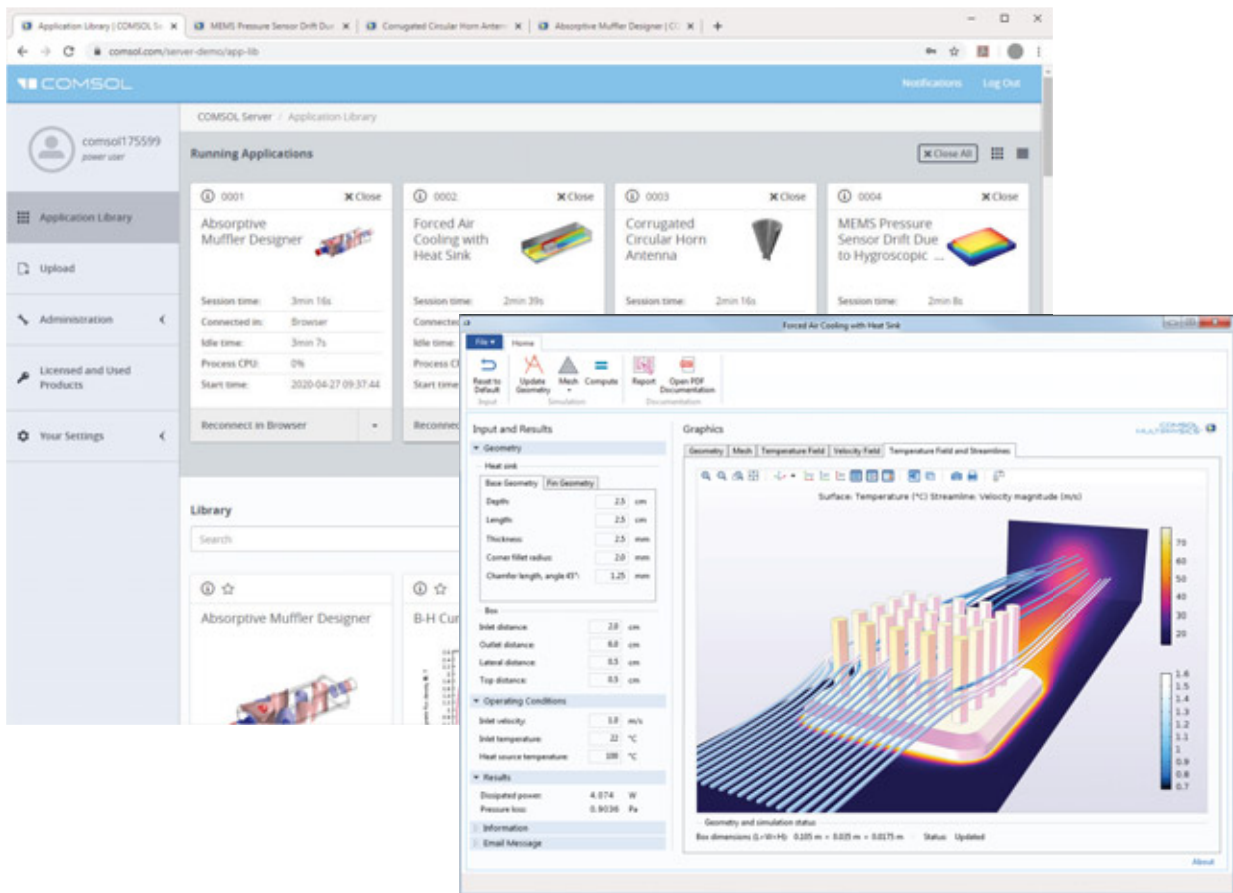

An example of a simulation application in the COMSOL Server™ application library. Application users can find an optimal heat sink design without having any knowledge of the underlying mathematical model.

Industry engineers and researchers are accelerating product development by building numerical simulation applications and deploying them throughout their organizations. COMSOL Multiphysics® enables you to build specialized applications, and COMSOL Server™ and COMSOL Compiler™ help you distribute them to the right contributors at the right time in your product development workflow.

The COMSOL Multiphysics® software is used for simulating designs, devices, and processes in all fields of engineering, manufacturing, and scientific research. See how you can apply it to product development.

comsol.blog/product-development



Free Info at <http://info.hotims.com/76508-847>