



SERIES 77 FULL NELSON

ENVIRONMENTAL SHRINK BOOTS

MIL-QUALIFIED • TACOM APPROVED • COMMERCIAL

FEBRUARY 2017

**SERIES 77
SHRINK BOOTS
AND ADAPTERS**

FULL NELSON

- SHRINK BOOTS
- CABLE TRANSITIONS
- CONVOLUTED BOOTS
- ADAPTERS



Series 77 Full Nelson Environmental Shrink Boots are now available in 5 additional materials, including Zero Halogen Polyolefin for regulated environmental safety applications and Low Outgassing Fluoropolymer Alloy that meets NASA requirements. Series 77 boots are also TACOM qualified to SC-X15111D specifications and our Type 1 high-performance material can be ordered in 10 optional colors to match cable colors or provide color coding. Properly applied, these adhesive-lined shrink boots provide a dependable, leak-proof seal for interconnect cable assemblies. If you are looking for an even quicker solution try our Piggyback boots which are supplied pre-shrunk onto the adapter, leaving you to only shrink the portion around the cable and reducing your production time. So if you're worried about sealing effectiveness, if you want long-lasting environmental protection, if you want an ingress prevention solution that won't lose its grip after years and years of service, get a Series 77 Full Nelson.

Glenair

Glenair, Inc.
1211 Air Way
Glendale, CA 91201-2497
818-247-6000
sales@glenair.com
www.glenair.com



SERIES 77 SHRINK BOOTS

Lipped and Lipless Shrink Boots

Table of Contents



Introduction	Table of Contents.....	A-1	Space Grade Shrink Boots.....	A-8	A
	Product Overview.....	A-2	Adhesive Performance Properties.....	A-12	
	Boot Selection Guide.....	A-3	Shrink Boot Installation Temperatures, and Adhesive/Shrink Boot Shelf Life.....	A-14	
	Material Properties and Fluid Resistance.....	A-4	Adhesive Material Specifications.....	A-16	
	Material Overview and Approvals.....	A-5	Boot Material Specifications.....	A-18	
	Modification Codes.....	A-6			
AS85049 Shrink Boots			Product Selection Guide.....	B-1	B
			M85049/140.....	B-2	
			M85049/141.....	B-10	
			M85049/142.....	B-16	
Lipped Adapter Shrink Boots			Product Selection and Reference Guide.....	C-1	C
			Straight.....	C-4	
			90°.....	C-24	
			45°.....	C-36	
Lipless Adapter Shrink Boots			Product Selection and Reference Guide.....	D-1	D
			Straight.....	D-4	
			Shim Boots (Straight).....	D-8	
			90°.....	D-10	
Series Specific Boots			Product Selection and Reference Guide.....	E-1	E
			SuperSeal.....	E-4	
			Nano.....	E-6	
			HiPer-D.....	E-8	
			SuperFly.....	E-10	
			Mighty Mouse.....	E-14	
"Wye" and "Tee" Wire Harness Routing Transitions			Product Selection and Reference Guide.....	F-1	F
			WYE Transition.....	F-2	
			TEE Transition.....	F-6	
			Multi-Leg Transitions.....	F-10	
Metal and Composite Shrink Boot Adapters			Shrink Boot Adapter Selection Guide.....	G-1	G
			Metal Adapter Reference Guide.....	G-2	
			Metal Adapters.....	G-8	
			Composite Adapter Reference Information.....	G-30	
			Composite Adapters.....	G-32	
Metal and Composite Piggyback Boot Adapters			Piggyback Boot Adapter Selection Guide.....	H-1	H
			Metal Piggyback Boot Reference Guide.....	H-2	
			Metal Piggyback Adapters.....	H-4	
			Composite Piggyback Boot Reference Guide.....	H-14	
			Composite Piggyback Adapters.....	H-16	
Adhesives and Installation Instructions			Heat Shrink Boot Installation Selection Guide.....	J-1	J
			General Boot Installation Guide.....	J-2	
			W1, W2, W3, R and U Adhesive Installation Guides.....	J-6	
			U Adhesive How to Order Information.....	J-10	
			Shrink Boot Installation Guide on Composite Parts.....	J-11	
Part Number Index and Cross-Reference			Part Number Index.....	K-1	K
			Tyco to Glenair Cross Reference.....	K-2	
			Hellerman to Glenair Cross Reference.....	K-38	



SERIES 77 SHRINK BOOTS

Heat Shrink Boots

Product Overview



Outstanding Environmental Protection and Strain Relief

A

Series 77 Full Nelson Shrink Boots

Heat shrink boots provide mechanical and environmental protection to connector-to-cable transitions. Specially formulated polymers are injection-molded, then heated and expanded. The shape-memory property of the material allows it to return to its original shape when heated with a hot air gun. Optional adhesive coatings on the inside of the boot provide a watertight, high-strength bond to the cable jacket and the connector or adapter.

RoHS Compliant

All Series 77 Shrink boots are fully RoHS compliant, including adhesive-lined versions.



Expanded Boots

Shrink boots are supplied in expanded form. The boot is heated, stretched on a mandrel, then cooled. The boot retains its expanded form until heat is applied.



Expanded Right Angle Boot

Recovered Boots

Application of heat restores the boot to its original dimensions.



Recovered Right Angle Boot

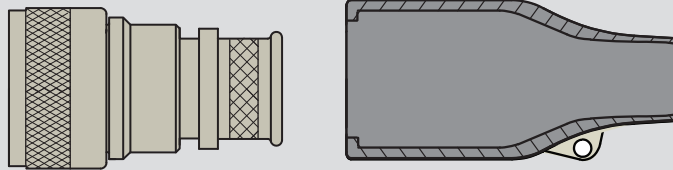

Lipped Boots

Lipped boots are designed for use with connector adapters which attach to AS85049 circular connectors. Adapters have a boot groove to accept an interlocking lip on the boot for improved strength. These adapters accept both shielded and unshielded cable. Adapters can be unthreaded from the connector for repair of damaged connector pins.

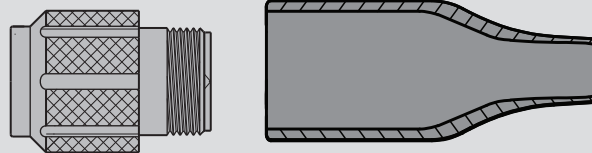

Lipless Boots

Lipless boots are designed for direct attachment to connector threads. The adapter is eliminated, saving weight and space. Adhesive lining provides sealing and improved mechanical strength.

Eyelets

Glenair offers standard, short, long and 90° lipped boots with an optional eyelet. Eyelets provide users a convenient way to attach connector accessories—such as lanyards and dust caps—directly to the shrink boot. All eyelets have a nominal .079 (2.0mm) inside diameter in the recovered state.

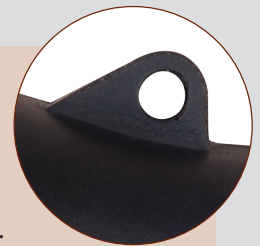

Available Boot Materials

Shrink boots, and multi-leg transitions are available in all eight materials: **Type 1** high performance elastomer provides improved resistance to heat, oils and fuels and is available in a wide range of colors including desert tan. **Type 2** zero halogen material is intended for applications where low toxicity is a must. **Type 3** general purpose flexible polyolefin is a good choice for occasional exposure to heat and chemicals. **Type 5** Viton polymer blend is highly flexible, fluid and temperature resistant. **Type 6** high-performance elastomer meets the SCX1512 specification and is ideal for use in molded shapes that require greater flexibility. **Type 7** flexible polyolefin boasts excellent fluid and solvent resistance, and is ideal for use in military and automotive applications. **Type 8** low outgassing fluoropolymer alloy meets NASA low outgassing test requirements. **Type 9** low temp flexible polyolefin is specifically designed for cables prone to damage from higher installation temperatures encountered with other material types.



SERIES 77 SHRINK BOOTS
Heat Shrink Boots
Boot Selection Guide



A

Lipped Shrink Boots for Use with Boot Adapters:



Standard Boots

770-001S, 770-003S, 770-016S,
 770-001A, 770-003A, 770-033A,
 770-001B, 770-003B and 770-034
 Available in twelve sizes in straight, 90°, 45°, and 30° profiles. Standard boots fit adapters from .250" (6.35) to 2.470" (62.70) diameter.



Short Boots

770-002S, 770-004S, 770-017S
 Available in seven sizes, short boots fit adapters from .450" (11.43) to 2.470" (62.70) diameter. Use where space is limited.



Long Tail Boots

770-006S, 770-020S, 770-006A, 770-021A
 Available in eleven sizes (straight) and nine sizes (right angle). Long tail boots fit adapters from .500" (12.70) to 3.200" (81.30) diameter, providing added protection to open wire bundles or extra-long stripped cable ends.



High Ratio Boots

770-007S, 770-007A
 Available in four sizes, in straight and 90° profiles. High ratio boots fit adapters from .525" (13.34) to 1.650" (41.91) diameter. Use high ratio boots when wire bundle or cable diameter is smaller than normal.



Heavy Wall

770-018S, 770-008S
 Available in six sizes and fit adapters from .350" (8.89) to 2.550" (64.80) diameter. 770-008S available in 2010 material only. 770-018 available in any material.



Convuluted Boots

770-022C
 Available in seven sizes, convoluted boots fit adapters from .250" (6.35) to 1.500" (38.10)

Lipless Boots for Direct Connector Attachment:



Standard Boots

770-005S, 770-019SB, 770-005A
 Available in eleven sizes (straight) and eight sizes (right angle). Standard straight boots fit connectors from .250" (6.35) to 3.200" (81.30) diameter. Right angle boots fit connectors from .250" (6.35) to 2.000" (50.80) diameter.

Connector Specific Boots for Glenair Connectors:



Series Specific

770-028S 38999 SuperSeal®
 770-029S Nanominiature
 770-030 HiPer-D® Elliptical
 770-031S SuperFly® Straight
 770-031A SuperFly® 90
 809-060 Mighty Mouse

Available for various Glenair connector families. These boots are developed specifically for our ever growing Interconnect product lines and backshell accessories.

Multi-Leg "Wye" and "Tee" Boots for Cable Assembly Routing Transitions:



"Wye" Transitions

770-009Y, 770-010Y
 Available in seven sizes and two body styles (low profile and wide body), "Y" transitions fit cables from Ø .200" (5.08) to .400" (10.16)



"Tee" Transitions

770-011T, 770-012T
 Available in four sizes and two body styles (low profile and wide body), "T" transitions fit cables from Ø .100" (2.54) to 1.250" (31.75)



1:3 and 1:4 Transitions

770-013, 770-014, 770-015
 Available in 1 to 3 (low profile and wide body) and 1 to 4 (wide body), multi-leg transitions fit cables from Ø .200" (5.08) to 2.00" (50.8)



SERIES 77 SHRINK BOOTS

Heat Shrink Boots



Material Properties and Fluid Resistance

A

Shrink Boot Typical Material Properties

Property	Type 1 High Performance Elastomer	Type 2 Zero Halogen Polyolefin	Type 3 General Purpose Polyolefin	Type 5 Viton Fluoroelastomer Blend	Type 6 High Performance Elastomer Alloy	Type 7 Flexible Polyolefin	Type 8 Low Outgassing Fluoropolymer Alloy	Type 9 Low Temp Flexible Polyolefin
Flexibility	Semi-rigid	Semi-flexible	Flexible	Flexible	Flexible	Highly Flexible	Semi-rigid	Flexible
Operating Temperature Range	-75°C to +150°C	-40°C to +130°C	-55°C to +135°C	-55°C to +150°C	-55°C to +135°C	-55°C to +135°C	-50° C to +175° C	-40° C to +100° C
Shrink Temperature (min.)	135°C	120°C	120°C	135°C	135°C	120°C	135°	70°
Tensile Strength (psi)	1700	1100	1400	2200	1500	1400	1700	1700
Elongation (% min.)	400	250	400	400	300	250	300	500
Thermal Endurance (Elongation 50% min)	3000 hrs, 150°C	3000 hrs, 130°C	--	--	--	--	--	--
Heat Shock	4 hrs, 215°C	4 hrs, 200°C	4 hrs, 225°C	4 hrs, 225°C	4 hrs, 220°C	4 hrs, 250°C	4 hrs, 225°C	4 hrs, 150°C
Heat Aging	168 hrs, 160°C	168 hrs, 175°C	168 hrs, 175°C	168 hrs, 150°C	168 hrs, 150°C	168 hrs, 175°C	168 hrs, 150°C	168 hrs, 175°C
Dielectric Strength (V/mil)	300	380	250	200	200	300	200	200
Volume Resistivity (ohms-cm)	10 ¹³	10 ¹²	10 ¹²	10 ¹⁰	10 ¹⁰	10 ¹²	10 ¹⁰	10 ¹⁰
Water Absorption (%)	0.5	0.5	0.5	0.5	0.5	0.5	0.5	0.5
Flammability	Burn Time <15 sec Burn Length <25mm	Burn Time <15 sec Burn Length <25mm	Burn Time <120 sec Burn Length <25mm	Burn Time <120 sec Burn Length <25mm	Burn Time <120 sec Burn Length <25mm	Burn Time <90 sec Burn Length <25mm	Burn Time <60 sec Burn Length <25mm	Burn Time <120 sec Burn Length <25mm
RoHS Compliant	Yes	Yes	Yes	Yes	Yes	Yes	Yes	Yes
Oxygen Index (% min.)	--	>30%	--	--	--	--	--	--
Temperature Index (°C)	--	>250° C	--	--	--	--	--	--
Smoke Index (max.)	--	<20	--	--	--	--	--	--
Toxicity Index (max.)	--	<3 Per 100 gms	--	--	--	--	--	--
Outgassing	--	--	--	--	--	--	CVCM <0.1% TML <1%	--

Shrink Boot Fluid Resistance

Fluid	Type 1 High Performance Elastomer	Type 2 Zero Halogen Polyolefin	Type 3 General Purpose Polyolefin	Type 5 Viton Fluoroelastomer Blend	Type 6 High Performance Elastomer Alloy	Type 7 Flexible Polyolefin	Type 8 Low Outgassing Fluoropolymer Alloy	Type 9 Low Temp Flexible Polyolefin
Lubricating Oil	Very good	Good	Good	Excellent	Excellent	Good	Excellent	Fair
Hydraulic Fluid	Very Good	Good	Good	Excellent	Excellent	Good	Excellent	Fair
Aviation Fuel	Very Good	Good	Good	Excellent	Excellent	Fair	Excellent	Fair
Gasoline	Very Good	Fair	Fair	Excellent	Excellent	Good	Excellent	Fair
De-Icing Fluid	Excellent	Very Good	Good	Excellent	Excellent	Good	Excellent	Fair
Automotive Diesel	Good	Fair	Very Good	Excellent	Excellent	Fair	Excellent	Fair



Type 1 High-Performance Elastomer Boots for Advanced Temperature and Chemical Tolerance

2025

- -75° C to +150° C
- *Very good resistance to fuels, oils, solvents and heat*

Semi-rigid high performance material combines excellent resistance to fuels, oils and solvents with superior performance at extreme temperatures. Rated for 3000 hours continuous operation at +150° C. Material meets the requirements of VG95343 Type 6, BSG 198-5-DE, EN62329-102 and SAE AS5258 Type H. This material is recommended for demanding applications such as military vehicles and petrochemical exploration. Available in standard black or 10 additional color choices listed below. Operating temperature is -75° C to +150° C

Mod Code Color Options for Type 1 Material					
Mod Code	Color	Similar to (Reference)	Mod Code	Color	Similar to (Reference)
632B	Blue	PANTONE 3005U	632R	Red	PANTONE 1797U
632E	Grey	FED-STD-595; #36270	632T	Tan	FED-STD-595; #33446
632G	Green	PANTONE 355U	632W	White	FED-STD-595; #37875
632P	Purple	FED-STD-595; #37100	632Y	Yellow	PANTONE YELLOW U
632O	Orange	FED-STD-595; #32300	Standard	Black	FED-STD-595; #37038
632OLV	Olive Green	FED-STD-595; #14087			

Material Color Options for Type 1 High Performance Elastomer ONLY. Add Optional Color Mod Code to End of Any Type 1 Material Part Number

Type 2 Low Smoke Zero Halogen (LSZH) For Regulated Environmental Safety Applications

2010

- *Low Smoke, Zero Halogen*
- *Meets U.S. and E.U. toxicity requirements*
- *Qualified to VG95343 Part 28 and 29*
- -40° C to +130° C

Halogen-free polyolefin material meets low smoke and toxicity requirements of shipboard, transit and aircraft systems. Oxygen index greater than 30%, smoke index less than 20, and toxicity index under 3 per 100 grams. Material meets requirements of NAVSEA 5617649, VG95343 Part 28 and 29, BSG 198-5-DF, EN62329-101 and SAE AS5258 Type G. Good resistance to oils, fuels and solvents. Temperature rating -40° to +130° C.

Type 3 Flexible Polyolefin For General Duty Applications

2040

- *General purpose harnessing*
- *Economical, flexible*
- -55° C to +135° C

Economical flexible polyolefin boots fit most standard shrink boot adapters, including M85049 adapters as well as Glenair Series 31 and Series 44 adapters. These self-extinguishing boots meet the requirements of SAE AS5258 Type B. Good resistance to oils and fuels. Available with optional hot melt adhesive lining, these boots provide strain relief and environmental protection to connector/cable transitions. Temperature rating -55° to +135° C. Black color.



A

Type 5 Viton® Fluoroelastomer Blend

2050

- *Excellent resistance to fuels, oils, solvents and heat.*
- *-55° C to +150° C*
- *Material meets specifications for SC-X15111D*

Flexible general duty boots combine excellent resistance to fuels, oils and solvents with superior performance at high temperatures. These boots fit most standard boot adapters for circular connectors. Material meets TACOM specifications for SC-X15111D. Viton boots are recommended where higher temperature and chemical resistance characteristics are required. Recommended for applications such as military vehicles and petrochemical exploration. Operating temperature is -55° C to +150° C

Type 6 High Performance Elastomer Alloy

2051

- *Excellent resistance to fuels, oils and solvents*
- *-55° C to +135° C*
- *Meets SC-X15112C Reqrmnt*

Flexible general duty boots combine excellent resistance to fuels, oils and solvents with good performance at higher temperatures. These boots fit most standard boot adapters for circular connectors. Material meets TACOM material specifications for SC-X15112C. Elastomer alloy boots are recommended where higher temperature and chemical resistance characteristics are required. Recommended for military and applications such as military vehicles. Operating temperature is -55° C to +135° C

Type 7 Flexible Polyolefin

2071

- *Good resistance to fuels, oils, solvents and heat*
- *-55° C to +135° C*

Semi-Flexible general duty boots combine good resistance to fuels, oils and solvents and high temperature tolerance. These boots fit most standard boot adapters for circular connectors. Material meets the requirements of AS5258 material A. Semi-flexible boots provide excellent cable support. Operating temperature is -55° C to +135° C

Type 8 Low Outgassing Fluoropolymer Alloy

2008

- *Meets NASA low out-gassing requirements*
- *-50° C to +170° C*

Semi-Rigid halogen-free polyolefin boots meet NASA low out-gassing test requirements and are suitable for high altitude and space applications. Excellent resistance to oils, fuels, solvents, acids and bases. Broad operating temperature of -50° C to +175° C provides excellent high temperature stability. Two-part 779-001 Glenair epoxy recommended.

Type 9 Low Temp Flexible Polyolefin

2013

- *Low shrink temperature*
- *-40° C to +100° C*

Flexible, low temperature heat-shrinkable polyolefin is developed for cable, such as Ethernet and USB cable, susceptible to heat damage from the application of boots with higher minimum shrink temperatures. Resistance to oils, fuels, solvents, acids and bases is fair. Operating temperature is -40° C to +100° C.

Approvals

Glenair Series 77 Shrink Boots are currently approved for: Airbus Defense & Space, Bomabardier, Gulfstream, TACOM, NAVSEA 5617649, M85049/140 (straight boots, /141 (90 degree boots) and /142 (wide-body transition including T, Y, and 1-to-3).



SERIES 77 SHRINK BOOTS

Heat Shrink Boots



Modification Code 672

Cut to Length Options for Long Tail Boots

Mod Code 672 can be added to the end of the part number development for cut-to-length options (typical for long tail series 770-006, 770-020, 770-021).

Mod Code	Table 1 Cut Length	
	Inches	mm
-6721	1.00	25.4
-6722	1.50	38.1
-6723	2.00	50.8
-6724	2.50	63.5
-6725	3.00	76.2
-6726	3.50	88.9
-6727	4.00	101.6
-6728	4.50	114.3
-6729	5.00	127.0
-67210	5.50	139.7
-67211	6.00	152.4
-67212	6.50	165.1
-67213	7.00	177.8
-67214	7.50	190.5
-67215	8.00	203.2
-67216	8.50	215.9

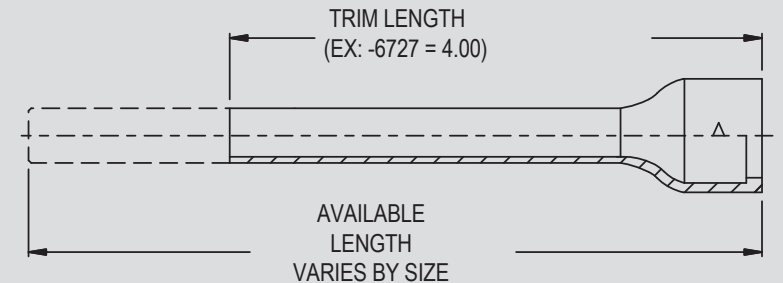

A

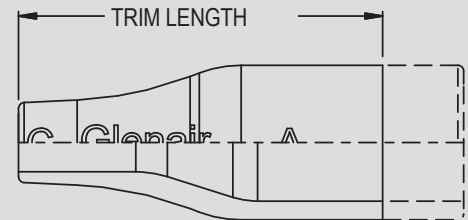
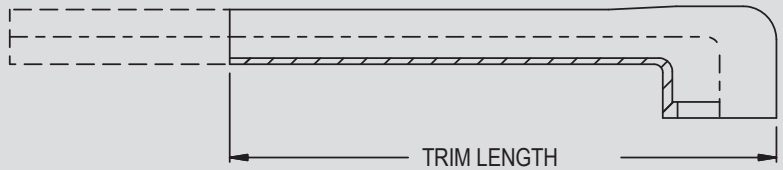

770-005S***

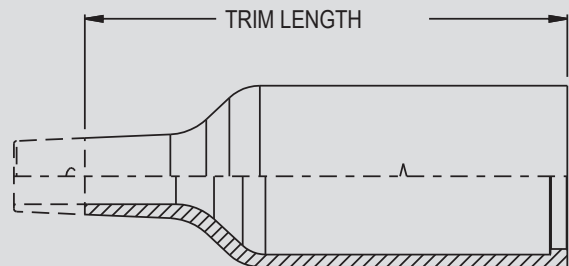

770-003S***

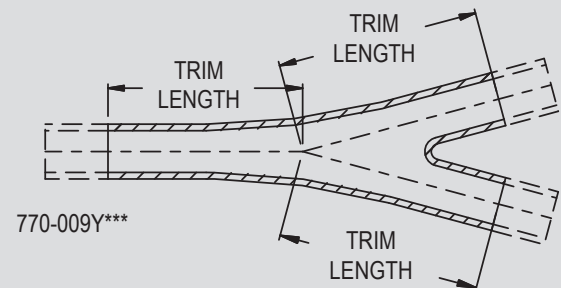

770-009Y***

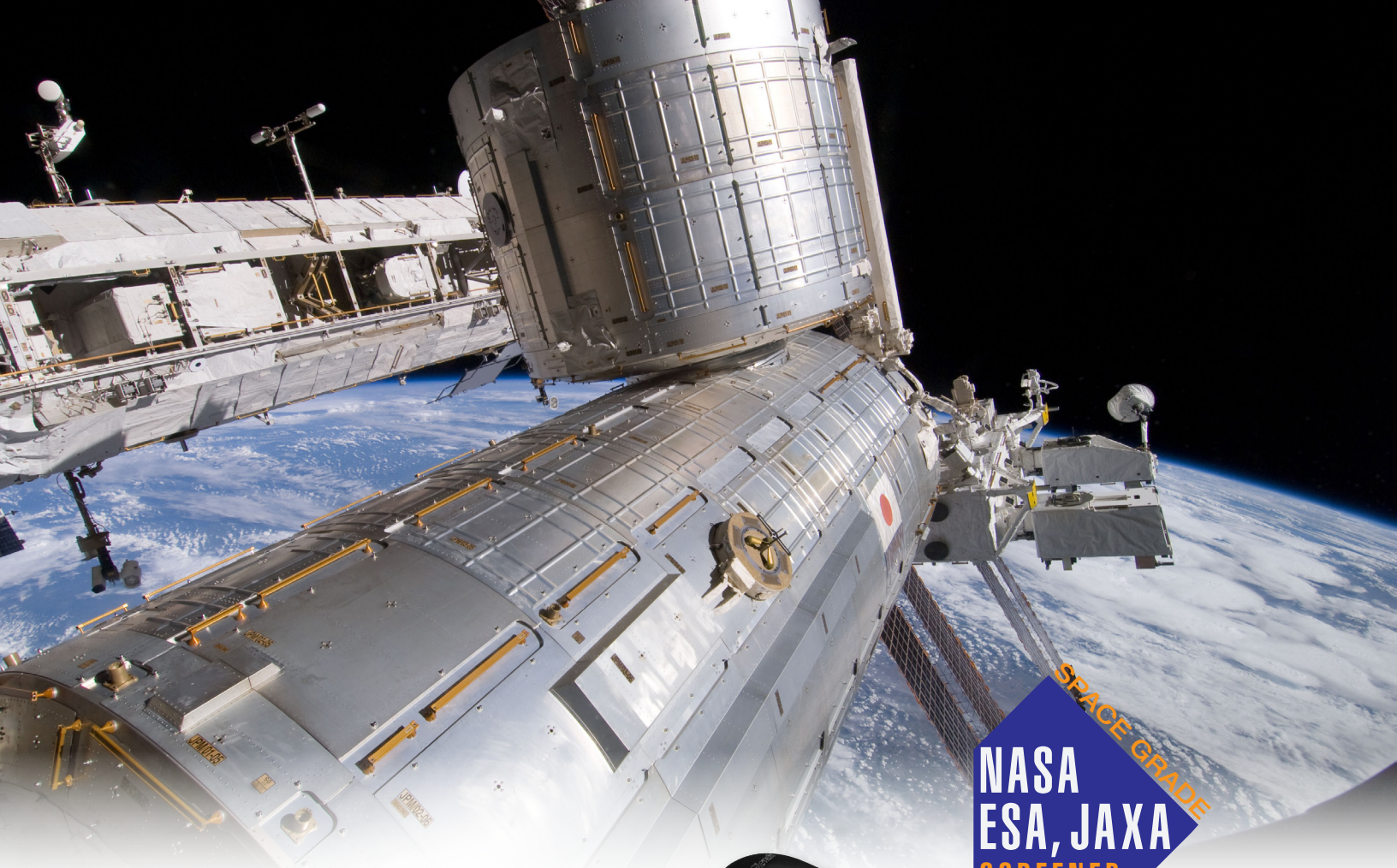

**NASA
ESA, JAXA
SCREENED**
SPACE GRADE

SERIES 77 TYPE 8 BOOT MATERIAL

Low outgassing space-grade shrink boots

Special fluoropolymer formula IAW ASTM E 595 provides mechanical strain relief, wire routing and environmental protection for electrical interconnect systems in space and high-altitude applications

Glenair's new type 8 low outgassing shrink boot material is ideally suited for the broad range of space vehicle, satellite, and station applications that require outgassing performance IAW ASTM E 595. The specially formulated polymer is injection molded in newly-manufactured mold tools that deliver precise dimensionality and professional appearance. Use Glenair two-part epoxy (part number 779-001) to achieve a watertight, high-strength bond to the cable jacket and the connector or adapter. A complete range of shrink boot types and styles may be supplied for connectors ranging from standard mil spec designs to Glenair small form factor solutions such as the Series 80 Mighty Mouse, Series 88 SuperFly, and others.



Standard Lipped
or Lipless Boots

- Standard, short, long, and 90° lipped and lipless boots
- Meets NASA outgassing requirements
- Compliant 2-part epoxy low-temperature adhesive available
- Glenair also offers the industry's largest selection of metal and composite shrink boot adapters
- Many Glenair connectors are equipped with integrated band and boot platforms



Also available:
Multibranch
Transitions

SERIES 77 TYPE 8

Low outgassing space-grade shrink boots

IAW ASTM E 595 fluoropolymer

GLENAIR TYPE 8 SPACE-GRADE LOW OUTGASSING SHRINK BOOTS AVAILABLE FOR ALL CONNECTOR TYPES INCLUDING:



GLENAIR TYPE 8 SPACE-GRADE LOW OUTGASSING SHRINK BOOTS AVAILABLE STYLES



Example Part Number Development: Straight and 90° Space-Grade Boots for Series 80 Mighty Mouse connectors*

Sample Part No.	809	A	060	-3	S	U	-PP
Space-Grade Shrink Boot	809 = Series 80 Mighty Mouse Shrink Boot						
Boot Angle	A = 90° S = Straight SL = Straight, long tail						
Basic part number	060 = Connector shrink boot with lip						
Size	-1, -2, -3, -4, -5, -6						
Material type	S = Low-outgassing fluoropolymer, NASA space-grade						
Adhesive	U = no adhesive						
Potting port	-PP = with potting port (Omit for none)						

*contact factory or visit www.glenair.com for how-to-order information on other boot types and styles

Testing IAW NASA Space-Grade Requirements

Test	Test Method	Test Requirement
Visual Examination		Homogenous and essentially free from pinholes, bubbles, flaws, cracks and inclusions, colour is black
Tensile Strength	IEC 62329-2	12 MPa minimum
Ultimate Elongation	IEC 62329-2	300% minimum
2% Secant Modulus	IEC 62329-2	100-125MPa
Specific Gravity	IEC 62329-2	< 1.4
Heat Ageing 168hrs at 150°C	IEC 62329-2	Tensile Strength 10.0 MPa minimum Ultimate Elongation 200 % minimum No Dripping, flow or cracking
Low temperature flexibility 4hrs at -40°C	IEC 62329-2	No Cracking on mandrel bend test.
Flammability	IEC 62329-2	Time of burning <60secs Length of burning <25mm
Water Absorption 24hrs At 23°C	IEC 62329-2	0.5% maximum
Outgassing	ASTM E595	CVCM < 0.1% TML <1%

Contact the factory for a copy of the full test report.





A

What is the Purpose of Adhesive Lined Shrink Boots?

Heat-shrink boots are not watertight unless equipped with factory-installed or user-installed adhesives. When heat is applied to the boot, the adhesive melts and fixes the boot to the adapter and cable jacket to provide the necessary sealing as well as mechanical strain-relief. Hot melt thermoplastic polyamide adhesive is compatible with most cable jackets, economical and easy to install. Glenair hot melt adhesives of this type are available in two temperature ranges: "W1" and "W3" for -55° to +125°C and "W2" for -55° to +70°C. But for maximum temperature range and best adhesion epoxy-lined boots are recommended. Glenair Type "R" one-part epoxy precoat provides protection from -75° to +150°C with high strength. *NOTE: This information summarizes the general performance values, test results and competitive advantages of the Glenair Series 77 adhesives. For unabridged adhesive test data please consult the factory.*

Table 2: Pre-Coated Boots Adhesive Information

Attribute	W1 High Temperature Hot Melt Adhesive	W2 Standard Hot Melt Adhesive	W3 High Performance Hot Melt Adhesive	R High Performance Epoxy Adhesive	U Two Part Epoxy Adhesive
Boot Material Compatibility	Types 1, 2, 5, 6 and 7	Types 1, 2, 3 and 7	Types 5 and 6	Type 1, 2 and 5	All Material Types
Continuous Operating Temp.	-55° to +125°C	-55° to +70°C	-55° to 125°C	-75° to +150°C	-75° to +150°C
Resistance to Fuels, Oils, and Fluids	Good	Good	Good	Excellent	Excellent
Low Toxicity, Zero Halogen	Yes	Yes	No	Yes	Yes

How is Adhesive Performance Measured?

There are three specifications for adhesives in the heat shrink world, SAE AS5258, VG95343 part 14, 15 and 18, and IEC 62329-3-101 and 102. All three specifications evaluate peel and shear strength for harness test assemblies. *NOTE: All Glenair adhesives and adhesive-lined boots meet or exceed their controlling specifications in every category—with ample safety margins (Type R adhesive is qualified to part VG95343 part 18).* While dynamic shear, static load, flexibility and peel adhesion may vary from one boot manufacturer to the next, all such products must meet the standards of the controlling specifications to be considered suitable for use in high-reliability applications.

Are All Adhesives that Satisfy the Controlling Specifications the Same?

Glenair's goal is to win over the market with high-quality products and outstanding customer service. As mentioned, we have designed our boots to meet or exceed all qualification standards with significant safety margins. But passing a test is only part of the story, since how well a boot "sticks" is a complex question that involves the boot material itself, a well-matched adhesive, the adhesive application process, and correct activation and installation by the user.

The most direct method to evaluate boot product design, processing, and installation is to apply a load to the boot-equipped cable at room and elevated temperatures. The load is either applied incrementally until failure mode is reached (dynamic shear) or with a set weight for a set period of time (static load). In other tests, adhesion is measured by peeling the moulded parts from connectors and cables.

Glenair uses adhesive-lined shrink boot products manufactured by Tyco/Raychem and Hellermann as benchmarks in all testing. The VG and SAE qualification standards have essentially been written with quoted values from these organizations' (principally Raychem's) own test suites. So when we say our products meet the standards in these controlling specifications, we are also stating categorically they perform competitively to other solutions available today. But this does not mean the products are all the same. Even though they all pass the same tests, in some areas the Glenair adhesive-lined boots outperform competitor products.



Head-to-Head Comparison of Adhesives

As stated, to provide comparable products and performance, Glenair adhesives are designed to match up against Raychem and Hellermann boot materials and adhesives. The four Glenair adhesives consist of a high performance two-part epoxy which is described as “U” in the USA and IEC specs, a one-part epoxy described as “R” in the USA and IEC specs and three pre-coated hot melts described as “W1, W2 and W3” in the USA and IEC specs. Manufacturer adhesive codes are explained in the following table:

Table 2: Glenair and Competitor Adhesive Code Descriptions

Adhesive Type	Description	Temp Range	Applicable Material	Glenair	Raychem	Hellermann
R	One-part epoxy, precoated	-75° to 150° C	Mil: A H Glenair: 1, 2, 5 Raychem: -3, -4, -12, -25, -100 Heller: B7, G	R	S1125	W24
U	Two-part epoxy, user installed	-75° to 150° C	Mil: A,B,G,H Glenair: All Materials Raychem: -3, -4, -25, -50, -100 Heller: B5, G, H	779-001	S1125	V9500
W1	Pre-coated hot melt wide temp range; low smoke zero hal	-55° to 125° C	Mil: A, B, G, H Glenair: 1, 2, 5, 6, 7 Raychem: -3, -4, -5, -25, -51, -71, -100 Heller: B5, G, H	W1	/86	W8, W21
W2	Pre-coated hot melt; limited temp range	-55° to 70° C	Mil: A, B, G Glenair: 1, 2, 3, 7 Raychem: -3, -4, -5, -25, 51, -71 Heller: J	W2	/42 /180	WM250
W3	Pre-coated hot melt; wide temp range	-55° to 125° C	Mil: A, B Glenair: 5, 6 Raychem: -3, -4, -51 Heller: J	W3	/164	WM200

Summary of Glenair Adhesive Materials

To provide comparable products and performance, Glenair adhesives are designed to match up on a functional basis against Raychem and Hellermann boot materials and adhesives. The following table summarizes the attributes of each Glenair adhesive:

U: Glenair two-part epoxy adhesive (type "U") is identical in make-up, performance and packaging to the Tyco/ Raychem (S1125) and Hellermann (V9500) materials. The material is simple to use, very reliable, providing the highest strength and requires no special installation procedures.

W1: Type “W1” is a polyamide hot melt adhesive, pre-coated onto heat shrink boots. The adhesive is versatile and bonds well to a variety of substrates. It possesses good creep resistance at elevated temperatures with excellent bond strengths at low temperature (-55°C to 125°C). The material has good resistance to fuels and oils. It provides excellent resistance to stresses with good peel adhesion. The “W1” adhesive provides a simple reliable technology for Glenair type 1, 2, 5, 6 and 7 boot materials. The material is low smoke, zero halogen and our tests show it provides superior performance to competitor products in both shear strength and peel adhesion—particularly in its adhesion and resistance to flex damage on the cable end.

W2: Type “W2” is an polyamide adhesive compatible with our type 3 boot material that provides very high levels of adhesion and sealing. The material has a limited temperature range of -55°C to +70°C and resists oils at room temperature. Our tests demonstrate this adhesive is equivalent in performance to Raychem and Hellermann materials.



SERIES 77 Heat Shrink Boots



Adhesives Performance Properties

A

W3: Type "W3" is a high performance polyester hot melt adhesive, pre-coated onto heat shrink boots. The adhesive is versatile and bonds well to a variety of substrates and ideal for applications where zero halogen is not a requirement. It possesses good creep resistance at elevated temperatures with excellent bond strengths at low temperature (-55°C to 125°C). The material has good resistance to fuels and oils. It provides excellent resistance to stresses with good peel adhesion. The "W3" adhesive provides a simple reliable technology for Glenair type 5 and 6 low profile boot materials. **Our tests show it provides superior performance to competitor products in both shear strength and peel adhesion—particularly in its adhesion and resistance to flex damage on the cable end.**

R: This is Glenair's highest performance pre-coated epoxy adhesive. The adhesive meets required specification levels of AS 5258 and VG 95343 part 18. Like the Raychem /225 adhesive and the Hellermann W24, **the material requires careful installation using trained operators.** The adhesive is capable of withstanding high stresses between -75°C and 150°C and prolonged high temperature immersion in fuels and oils. Peel adhesion is very high to a wide range of materials used to manufacture connectors or backshells including aluminium with various types of plating as well as plated and unplated composite thermoplastics. Type "R" can be used on most cable jacket materials including fluorocarbon rubbers, although fluropolymers such as ETFE and PVDF require surface treatment. **Note: The Glenair one part pre-coated adhesive does not match Raychem /225 for peel adhesion but is much better in direct shear and has better handling properties. The material exhibits no cracking on flexing dynamic shear tests confirming its superior flex resistance—particularly on the cable end of the test assembly.**

The following table lists the controlling specifications for type "R", high-performance adhesives:

Table 3: Specification Requirements for Type "R" Adhesives			
Test	TEMP	SAE AS5258	VG95343
Dynamic Shear	23 C	300 N	300 N
	100 C	110 N	110 N
Static Load	23 C	20 kgs	20 kgs
	100 C	5 kgs	5 kgs
Sealing Test (1 bar pressure)	23 C		No leaks
Peel Adhesion	23 C	67 N/25mm	60 N/25mm

Again, it bears repeating, the Glenair type "R" adhesive meets all the above requirements with significant safety margins. The material delivers Peel Adhesion test values of 100 N/25mm and Dynamic Shear values of 820 N. The Tyco/Raychem /225 adhesive also tests above the requirement with Peel Adhesion test values of 140 N/25mm but with Dynamic Shear values of only 540 N.

Conclusion

Glenair has a range of adhesives that meet the published specifications to enable reliable adhesion and long system life. Comparing the five adhesives, **the "779-001" and "R" epoxies are functionally identical**, "W1" hot melt is superior, "W2" is halogen free, covers the required range and is equivalent, "W3" hot melt covers required range and is equivalent.

Glenair's one part pre-coated adhesive ("R") does not match Raychem /225 for peel adhesion but is better in direct shear, has better handling properties, and delivers better flex resistance performance. When installed properly, the material easily meets the "gorilla test" since a peeling force of 100N/25mm (25 lbs) is easily more than a normal person can exert with their fingers. Again, our tests demonstrate the Glenair boot with "R" adhesive is a superior performing product due to its advanced resistance to flex damage such as separation and cracking on the cable-end of the assembly. For complete test result, or a product sample, please contact the factory.



SERIES 77 Heat Shrink Boots



Installation Temperatures and Shrink Boot Adhesive Shelf Life



Heat Shrinkable Boot Installation Temperatures

Heat Shrink Boots are usually installed with a hot air gun. The temperature that the material must reach to cause the boots to shrink is given below. It should be noted that excess temperatures can cause the material to blister and smoke. Excessive temperature do not cause the boots to shrink faster, the rate determining step is the thermal transfer through the body of the part. Boots with large thick sections require more time for the boot to reach shrink temperature. Applying hotter than recommended air will cause damage to the boot.

MATERIAL	MINIMUM TEMPERATURE	RECOMMENDED TEMPERATURE
Type 1	135°C (275°F)	175°C (350°F)
Type 2	120°C (250°F)	150°C (300°F)
Type 3	120°C (250°F)	150°C (300°F)
Type 5	135°C (275°F)	175°C (350°F)
Type 6	135°C (275°F)	150°C (300°F)
Type 7	120°C (250°F)	150°C (300°F)
Type 8	135°C (275°F)	175°C (350°F)
Type 9	70°C (160°F)	100°C (210°F)

Heat Shrink Boot Adhesive Shelf Life

Glenair offers a range of adhesives to be used with the Series 77 Shrink Boots and these are a pre-coated 150°C epoxy adhesive type "R", three pre-coated hot melt adhesives "W1", "W2" and "W3" and a two part epoxy "779-001".

Shelf life has been determined because types "R", "W1" and "779-001" adhesives meet the requirements of German VG standards to which the systems have been qualified to. The "R" pre coated adhesive is qualified to VG 95343-18 and this specifies a 3 year shelf life for the adhesive coated heat shrink boot.

The "W1" pre coated adhesive is qualified to VG 95342-29 and this specifies 5 year shelf life for the adhesive coated heat shrink boot.

The two part epoxy "779-001" meets the requirements of VG 95345-15 and this specifies 18 months shelf life.

"W2" pre coated adhesive meets the requirements of the EN 62328 that gives a minimum life of 2 years, however Glenair testing shows it will meet the 5 years shelf life of "W1" adhesive.

"W3" pre coated adhesive is qualified to the TACOM Part No 12287273 but this does not specify shelf life. Glenair testing shows the material exceeds 5 years shelf life.

As such all adhesive pre-coated heat shrink boots using "R", have a 3 year shelf life. Boots coated with "W1", "W2" and "W3" have a 5 year shelf life as does the "W4" tape. The two part epoxy 779-001 has an 18 months shelf life.

The times given for each material are from when the customer receives the pre coated parts or the adhesive. The parts may have other codes on the packaging indicating dates when the parts were either packed or manufactured. However this does not change the shelf life specified by Glenair which applies from when the parts are shipped. During any holding time the parts are held, the storage conditions are strictly controlled.



SERIES 77
Heat Shrink Boots
Shrink Boot Shelf Life



A

Heat Shrinkable Boot Shelf Life

Glenair offers a number of heat-shrinkable boot materials in the Series 77 Shrink Boot range. The shelf life of the boots (without adhesive pre-coating, see document on "Heat Shrink Boot Adhesive Shelf Life") is described below for each type. The shelf life is determined by there being no degradation of the materials properties from original specification and the dimensions both expanded and recovered being to the specification control drawing. The specified times depend on the storage being under normal ambient which means below 35°C and not in direct sunlight. Attention should be made as to transport because it is known that containers in direct sunlight can reach temperatures of 50°C. This will not affect the properties of the materials but may cause a limited amount of recovery to occur depending on the length of time the boots are exposed to high temperatures. This is especially relevant to type 2, 7 and 9 materials and small size boots.

Materials

Type 1 & 2: 5 years

The shelf life of these boots, when stored under ambient conditions (below 35° C), is part of the qualification to the German VG 95343 qualification for 2025 Type 1 material and 2010 Type 2 material. Material in this specification has to meet 100% of the specified values for strength and performance after 5 years.

Type 3 & 7: 4 years

The shelf life under the same storage conditions for 2040 Type 3 material and 2071 Type 7 materials are given in MIL-I-81765 and is 4 years.

Type 5 & 6: 4 years

The shelf life for 2050 Type 5 material and 2051 Type 6 materials are not specified in any military specification. Accelerated aging tests carried out by Glenair give a shelf life of greater than 4 years.

Type 8: 4 years

This material is not qualified to any International Specification and Glenair accelerated ageing shows the material will meet at least 5 years shelf life and we have therefore given it a 4 year life.

Type 9: 2 years

This material has a very low shrink temperature and will start to show recovery at 35°C and because of this the shelf life is restricted to 2 years.

The times given for each material are from when the customer receives the parts. The parts may have other codes on the packaging indicating dates when the parts were either packed or manufactured. However this does not change the shelf life specified by Glenair which applies from when the parts are shipped. During any holding time the parts are held, the storage conditions are strictly controlled.



SERIES 77
Heat Shrink Boots



Type W1 Adhesive Quality Standards
Pre-Coated Polyamide Hot Melt Adhesive

A

Harness Systems Quality Assurance, GTS 4067 Specification
Suitable for Type 1, 2 and 7 Materials
-55°C to +125°C Temperature Range

This Quality Assurance Specification establishes the quality standard for a heat-shrinkable elastomeric boots supplied pre-coated with Type W1 Hot Melt Adhesive. System tests; size S06 boots with 25mm aluminum backshells shall be used. Cable jacket shall be ZHTM tubing for 2010 compound and DR 25 for 2025 compound. (Tubing size 3/4 inch, supplied by Raychem) Material for boot manufacture shall comply with relative GTS specification. Refer to product guide for condition to shrink boots. All tests to be carried out 7 days after installation. Epoxy adhesive with wide temperature range, from -55°C to 125°.

Type W1 Pre-Coated Polyamide Hot Melt Adhesive - Materials Specification

Test	Test Method	Test Requirement
Dynamic Shear Testing Test Temperature 23°C 10°C	IEC 62329-2	Tensile Force Min 300N 30 N
Static Load Test Temperature 23°C 105°C Load 10kgs 0.5kgs	IEC 62329-2	Dynamic Shear 300 N Maximum Movement 15mm
Heat Aging 168hrs at 105°C	IEC 62329-2	Peel Adhesion >60 N/25mm Dynamic Shear >300 N
Fluid Resistance 24hr Immersion at 23°C Lubricating Oil 0-156 Aircraft Grease G-354 Hydraulic Fluid H-520 Water Turbine Fuel F-34	IEC 62329-2	Dynamic Shear 150 min
Peel Adhesion Boot to Adapter Boot to Cable	IEC 62329-2	>60 N/25mm >60 N/25mm
Halogen Content	IEC 62329-2	<0.2%

Approved to: VG 95343 Part 28 with Type 2 material



SERIES 77
Heat Shrink Boots



Type W2 Adhesive Quality Standards
Pre-Coated Hot Melt Adhesive

A

Harness Systems Quality Assurance, GTS 4088 Specification
Suitable for Type 3 and 9 Materials
-55°C to +70°C Limited Temperature Range

This Quality Assurance Specification establishes the quality standard for a heat-shrinkable elastomeric boots supplied pre-coated with Type W2 Hot Melt Adhesive. System tests; size 7600 boots with 25mm aluminum backshells shall be used. Cable jacket shall be RNF 100 for 2040 compound, type 3 material (tubing size 1/2 inch, supplied by Raychem). Material for boot manufacture shall comply with relative GTS specification. Refer to product guide for condition to shrink boots. All tests to be carried out 7 days after installation. Hot melt Adhesive with limited temperature range from -55°C to 70°C.

Type W2 Polyamide Pre-Coated Hot Melt Adhesive - Materials Specification

Test	Test Method	Test Requirement
Dynamic Shear Testing Test Temperature 23°C 70°C	IEC 62329-2	Tensile Force Min 150 N 30 N
Static Load Test Temperature 23°C 70°C Load 10kgs 0.5kgs	IEC 62329-2	Dynamic Shear 150 N Maximum Movement 15mm
Heat Aging 168hrs at 105°C	IEC 62329-2	Peel Adhesion >60 N/25mm Dynamic Shear >150 N
Fluid Resistance 24 hr immersions at 23°C Lubricating oil O-156 Aircraft Grease G-354 Hydraulic Fluid H-250 Turbine Fuel F-34	IEC 62329-2	Dynamic Shear >150N
Peel Adhesion Boot to Adapter Boot to Cable	IEC 62329-2	>60 N/25mm >60 N/25mm



SERIES 77
Heat Shrink Boots



Type W3 Adhesive Quality Standards
Pre-Coated Polyester Hot Melt Adhesive

Harness Systems Quality Assurance, GTS 4132 Specification
Suitable for Type Low Profile Parts Type 5 and 6 Materials
-55°C to +125°C Temperature Range

A

This Quality Assurance Specification establishes the quality standard for heat-shrinkable elastomeric boots supplied pre-coated with type W3 hot melt adhesive. System tests: size S06 boots with 25mm aluminium backshells shall be used. Cable jacket shall be NT tubing and Viton tubing, size 3/4 inch, supplied by Raychem. Material for boot manufacture shall comply with relative GTS specification. Refer to product guide for condition to shrink boots. All tests to be carried out 7 days after installation. High performance hot melt adhesive with wide temperature range from -55°C to 125°C

Type W3 Pre-Coated Polyester Hot Melt Adhesive - Materials Specification

Test	Test Method	Test Requirement
Dynamic Shear Testing Test Temperature 23°C 105°C	IEC 62329-2	NT and Viton Tubing Tensile Force Min 300 N 30 N
Static Load Test Temperature Load 23°C 10kgs 105°C 0.5kgs	IEC 62329-2	NT and Viton Tubing Dynamic Shear 300 N Maximum Movement 4mm
Heat Aging 168hrs at 105°C	IEC 62329-2	NT and Viton Tubing Peel Adhesion >60 N/25mm Dynamic Shear >300 N
Fluid Resistance 24hr Immersion @ 50°C Lubricating Oil 0-156 Diesel Fuel Hydraulic Fluid H-540 Turbine Fuel F-34 Cleaning Fluid P-C-437	IEC 62329-2	NT and Viton Tubing Dynamic Shear 150 min
Peel Adhesion Boot to Adapter Boot to Cable (NT and Viton®)	IEC 62329-2	>60 N/25mm >60 N/25mm

Approved to: TACOM 12287273 Rev K adhesive tape



SERIES 77
Heat Shrink Boots



Type R Adhesive Quality Standards
Pre-Coated One-Part Epoxy Adhesive

A

Harness Systems Quality Assurance, GTS 4087 Specification
Suitable for Type 1 Materials
Temperature Range: -75°C to +150°C

This Quality Assurance Specification establishes the quality standard for a heat-shrinkable elastomeric boot supplied pre-coated with Type R Epoxy Adhesive. For system tests, size S06 boots with a 25mm aluminum backshells and 10mm Raychem DR25 jacketed cable shall be used. Material for boot manufacture shall comply with GTS 4025. Refer to the product guide for condition to shrink boots. All tests to be carried out 10 days after installation.

Type R Pre-Coated One-Part Epoxy Adhesive - Materials Specification

Test	Test Method	Test Requirement
Dynamic Shear Testing Test Temperature 23°C 100°C 150°C (with aluminum rod)	IEC 62329-2	Tensile Force Min 300N 110 N 30 N
Static Load Test Temperature Load 23°C 20kgs 100°C 5kgs 150° 2 kgs	IEC 62329-2	Dynamic Shear 300 N Maximum Movement 15mm
Heat Shock 4hrs at 215°C	IEC 6239-2	Peel Adhesion >60 N/25mm Dynamic Shear >300 N
Heat Aging 168hrs at 160°C	IEC 62329-2	Peel Adhesion >60 N/25mm Dynamic Shear >300 N
Fluid Resistance 24hrs Immersion @ 70°C Lubricating Oil 0-156 Aircraft Grease G-354 Hydraulic Fluid H-520 Water Turbine Fuel F-34	IEC 62329-2	Dynamic Shear 150 min
Peel Adhesion Boot to Adapter Boot to Cable	IEC 62329-2	>60 N/25mm >60 N/25mm

Material Qualified and Approved to: VG95343 part 18



SERIES 77

Heat Shrink Boots



Type U Adhesive Quality Standards High-Performance 2-Part Epoxy Adhesive

Harness Systems Quality Assurance, GTS 4066 Specification
Suitable for all Material Types: 1, 2, 3, 5, 6, 7, 8,9
Temperature Range: -75°C to +150°C

A

This Quality Assurance Specification establishes the quality standard for a two-part epoxy adhesive supplied in a 50cc duo syringe, part number 779-001. The adhesive conforms to the requirements of VG 95343-15 and SAE AS5258 adhesive code U, test methods are referenced for VG standard.

Type U High Performance 2-Part Epoxy Adhesive - Materials Specification

Test	Test Method	Test Requirement
Aluminum Lap Shear Test Temperature -55°C 23°C 50°C 70°C 100°C 120°C 150°C	VG 95343-2 5.1	Shear Force min 5 kN 5 kN 3.5 kN 2.5 kN 1.5 kN 1.3 kN 1 kN
Fluid Resistance NATO Ctock No. F34 O-156 O-236 G-354 S-1720 H 520 F 67 H 544	VG-95343-15	Lap Shear 5 kN min
Heat Shock 24hrs at 215°C	VG-95343-15	Lap Shear 5 kN min
Heat Aging 168hrs at 160°C	IEC 62329-2	Lap Shear 5 kN min
Peel Adhesion Boot to Adapter Boot to Cable	IEC 62329-2	>60 N/25mm >60 N/25mm

Approved to: TACOM 12347278 Rev B two-part epoxy



SERIES 77
Heat Shrink Boots



Compound Material Performance Specifications
Type 1 Material: 2025 Flame Retarded

A

GTS 4025: Oil Resistant and Flame Retarded, Heat-Shrinkable Elastomeric Compound
Temperature Range: -75°C to 150°C

This Quality Assurance Specification establishes the quality standard for a heat-shrinkable elastomeric compound used to manufacture Glenair® molded components. Dimensions of molded shapes are specified in SCD 770-001/2. All testing to be carried out on molded sheets 2mm thick unless otherwise specified. For system tests size S06 boots with 25 mm aluminum backshells and 10mm DR-25 (Raychem) jacketed cable shall be used. Adhesive type U from IEC 62329 shall be used (Glenair 779-001).

Installation Temperature: Minimum 135°C, Recovered 175°C

Compound 2025 Type 1 - Materials Specification		
Test	Test Procedure	Test Requirement
Visual Examination		Homogenous and essentially free from pinholes, bubbles, flaws, cracks and inclusions, color is black
Tensile Strength	IEC 62329-2	12Mpa minimum
Ultimate Elongation	IEC 62329-2	400% minimum
2% Secant Modulus	IEC 62329-2	80 – 160MPa
Specific Gravity	IEC 62329-2	1.4 Max
Heat Shock 4hrs at 215°C	IEC 62329-2	No dripping or flow Helical bend 20mm diameter, no cracking Tensile strength 12 MPa minimum Ultimate elongation 400% minimum
Heat Aging 168hrs at 160°C	IEC 62329-2	Tensile strength 12 MPa minimum Ultimate elongation 400 % minimum
Thermal Endurance 3000 hrs at 150°C	IEC 62329-2	Ultimate elongation 50% minimum low temperature
Low Temperature Flexibility 4hrs at -75°C	IEC 62329-2	No cracking
Flammability	IEC 62329-2	Time of burning < 15secs Length of burning < 25mm
Water Absorption 24hrs at 23°C	IEC 62329-2	0.5% maximum
Electric Strength	IEC 62329-2	12 MV/m minimum
Volume Resistivity After Damp Heat	IEC 62329-2	10 ¹³ ohms cms minimum
Copper Mirror Corrosion	IEC 62329-2	No corrosion
Fungus Resistance	IEC 62329-2	Tensile strength 12MPa min elongation at break 400% min



SERIES 77
Heat Shrink Boots



Compound Material Performance Specifications
Type 1 Material: 2025 Flame Retarded

A

Compound 2025 Type 1 - Materials Specification		
Test	Test Procedure	Test Requirement
Fluid Resistance 24hrs immersion in : ISO Octane/Toluene (70/30) at 40°C Lubricating Oil 0-156 at 100°C Lubricating Oil 0-236 at 100°C Lubricating Oil 0-190 at 70°C Aircraft Grease G-354 at 70°C Hydraulic Fluid H-515 at 70°C Damping Fluid S-1724 at 70°C Damping Fluid S-1720 at 40°C Brake Fluid H-542 at 50°C Hydraulic Fluid H-544 at 70°C Hydraulic Fluid Phosphate Ester at 23°C H-580 at 23°C De-icing Fluid S-745 at 70°C Anti Freeze Ethylene glycol/water at 70°C Turbine Fuel F-34 at 70°C Automotive Gasoline F-67 at 70°C Automotive Diesel ISO-1827 B at 70°C Propan-2-ol (S737) at 70°C	IEC 62329-2	Tensile Strength 10 MPa minimum Ultimate Elongation 300% minimum
Dimensional Stability 14 days at 40°C	IEC 62329-2	Measured dimensional values both expanded and recovered in specification
Dynamic Shear Room Temperature 100°C	IEC 62329-2	>300 N 10mm cable >100 N 10mm cable
Static Load Room Temperature 4hrs 20kgs 100°C 4hrs 5kgs	IEC 62329-2	<15mm movement 10mm cable <15mm movement 10mm cable
Peel Adhesion Boot to Adaptor Boot to Cable	IEC 62329-2	>60N/25mm >60N/25mm

Material is approved and qualified to VG 95343 part 16, AS5258 Material H, IEC 62329-2-102 and meets the requirements of SCX1511.



SERIES 77
Heat Shrink Boots



Compound Material Performance Specifications
Type 2 Material: 2010 Limited Fire Hazard

A

GTS 4063: Heat-Shrinkable, Semi-Rigid, Limited Fire Hazard, Polyolefin
Temperature Range: -40°C to 130°C

This Quality Assurance Specification establishes the quality standard for a heat-shrinkable limited fire hazard compound used to manufacture Glenair® molded components. All testing to be carried out on molded sheets 2mm thick unless otherwise specified. For system tests size S06 boots with 25mm aluminum backshells and 10mm ZHTM (Raychem) jacketed cable shall be used. Systems testing shall use W1 adhesive.

Installation Temperature: Minimum 120°C, Recovered 150°C

Compound 2010 Type 2 - Materials Specification		
Test	Test Procedure	Test Requirement
Visual Examination		Homogenous and essentially free from pinholes, bubbles, flaws, cracks and inclusions, color is black
Tensile Strength	IEC 62329-2	8 Mpa minimum
Ultimate Elongation	IEC 62329-2	250 % minimum
2% Secant Modulus	IEC 62329-2	50 – 130MPa
Specific Gravity	IEC 62329-2	1.4 Max
Heat Shock 4hrs at 200°C	IEC 62329-2	No dripping or flow Tensile Strength 5 MPa minimum Ultimate Elongation 150% minimum
Heat Aging 168hrs at 175°C	IEC 62329-2	Tensile Strength 5 MPa minimum Ultimate Elongation 150 % minimum
Long Term Heat Aging 3000hrs @ 130°C	IEC 62329-2	Ultimate Elongation at break 100 % min
Low Temperature Flex -40°C 20mm mandrel	IEC 62329-2	No Cracking
Water Absorption 24hrs at 23°C	IEC 62329	0.5% maximum
Flammability	EN 62329-2	Time of burning < 15secs Length of burning < 25mm
Electric Strength	EN 62329-2	15 MV/m minimum
Volume Resistivity After Damp Heat	EN 62329-2	10 ¹² ohms cms minimum
Copper Mirror Corrosion	EN 62329-2	No corrosion
Fungus Resistance	EN 62329-2	Tensile strength 7 MPa min Elongation at break 200% min
Oxygen Index	IEC 62329-2	> 30%
Temperature Index	IEC 62329-2	>250°C
Smoke Index	IEC-62329-2	< 20
Toxicity Index	IEC 62329-2	<3 per 100grams



SERIES 77
Heat Shrink Boots



Compound Material Performance Specifications
Type 2 Material: 2010 Limited Fire Hazard

A

Compound 2010 Type 2 - Materials Specification		
Test	Test Procedure	Test Requirement
Acid Gas Generation	IEC 62329-2	PH min 4.3; conductivity <10.5S
Halogen Content	IEC 62329-2	<0.2%
Fluid Resistance 24 hrs immersion @ 23°C : Lubricating Oil 0-156 Lubricating Oil 0-149 Hydraulic Fluid H-520 Damping Fluid S-1720 Hydraulic Fluid Skydrol H580 Antifreeze Ethylene Glycol/Water Turbine Fuel F-34 Automotive Gasoline F-67 Isopropyl Alcohol Methyl Ethyl Ketone 1	IEC 62329-2	Tensile Strength 5 MPa minimum Ultimate Elongation 150% minimum
Dimensional Stability 14 days at 40°C	EN 62329-2	Measured dimensional values both expanded and recovered in specification
Dynamic Shear Room Temperature 105°C	EN 62329-2	>300 N 10mm cable >30 N 10mm cable
Static Load Room Temperature 4hrs 10kgs 105°C 4hrs 0.5kgs	EN 62329-2	<15mm movement 10mm cable <15mm movement 10mm cable
Peel Adhesion Boot to Adaptor Boot to Cable	IEC 62329-2	>60N/25mm >60N/25mm

Material qualified to: VG95343 part 28 and 29, AS5258 Material G, NAVSEA 5617649 and IEC 62329-3-101



SERIES 77
Heat Shrink Boots



Compound Material Performance Specifications
Type 3 Material: 2040 Flexible Polyolefin

A

GTS 4064: Heat-Shrinkable, Flexible Polyolefin
Temperature Range: -55°C to 135°C

This Quality Assurance Specification establishes the quality standard for a heat-shrinkable flexible polyolefin compound used to manufacture Glenair® molded components. All testing to be carried out on molded sheets 2mm thick unless otherwise specified. For system tests size S06 boots with 25mm aluminum backshells and 10mm RNF 100 (Raychem) jacketed cable shall be used. Adhesive Type W2 from IEC 62329 shall be used.

Installation Temperature: Minimum 120°C, Recovered 150°C

Compound 2040 Type 3 - Materials Specification		
Test	Test Procedure	Test Requirement
Visual Examination		Homogenous and essentially free from pinholes, bubbles, flaws, cracks and inclusions, color is black
Tensile Strength	IEC 62329-2	10MPa minimum
Ultimate Elongation	IEC 62329-2	400% minimum
2% Secant Modulus	IEC 62329-2	<80 MPa
Hardness Shore A		85-90
Specific Gravity	IEC 62329-2	1.4 Max
Heat Shock 4hrs at 225°C	IEC 62329-2	No dripping or flow Tensile strength 8 MPa minimum Ultimate elongation 200% minimum
Heat Aging 168hrs at 175°C	IEC 62329-2	Tensile strength 8 MPa minimum Ultimate elongation 200 % minimum
Low temperature Flexibility 4hrs at -55°C	IEC 62329-2	No cracking
Flammability	IEC 62329-2	Time of burning < 120secs Length of burning < 25mm
Water Absorption 24hrs at 23°C	IEC 62329-2	0.5% maximum
Electric Strength	IEC 62329-2	10 MV/m minimum
Volume Resistivity	IEC 62329-2	10 ¹² ohms cms minimum
Copper Mirror Corrosion 16hrs @ 150°C	IEC 62329-2	No corrosion
Fungus Resistance	IEC 62329-2	Tensile strength 8MPa min Elongation at break 200% min
Fluid Resistance 24hrs immersion @ 23°C Hydraulic Fluid H-520 Hydraulic Fluid Phosphate Ester Turbine Fuel F-34 Automotive Gasoline F-67 Automotive Diesel ISO-1827 B Water	IEC 62329-2	Tensile strength 6 MPa minimum Ultimate elongation 200% minimum
Dimensional Stability 14 days at 40°C	IEC 62329-2	Measured dimensional values both expanded and recovered in specification

Material Qualifies to AS5258 Material B



SERIES 77
Heat Shrink Boots



Compound Material Specifications
Type 5 Material: 2050 Viton

GTS 4078: Heat-Shrinkable, Viton Polymer Alloy (VPA)
Operating Temperature Range: -55° to 150°C

This Material Specification establishes the quality standard for a heat-shrinkable VPA compound used to manufacture Glenair® molded components. Dimensions of molded shapes are specified in SCD7090. All testing to be carried out on molded sheets 2mm thick unless otherwise specified. For system tests size S06 boots with type 779-001 two part epoxy adhesive with 25mm aluminum backshells and 15mm Viton jacketed cable shall be used.

Installation Temperature: Minimum 135°C, Recovered 175°C

A

Compound 2050 Type 5 - Materials Specification

Test	Test Procedure	Test Requirement
Visual Examination		Homogenous and essentially free from pinholes, bubbles, flaws, cracks and inclusions, color is black
Tensile Strength	IEC 62329-2	15.2MPa minimum
Ultimate Elongation	IEC 62329-2	350% minimum
Hardness	IEC 62329-2	85 ± 10 Shore A
Stiffness	ASTM D747	<40MP
Specific Gravity	IEC 62329-2	< 1.5
Heat Shock 4hrs at 225°C	IEC 62329-2	No dripping or flow helical bend 20mm diameter, no cracking Tensile strength 13.8 MPa minimum Ultimate Elongation 300% minimum
Heat Aging 168hrs at 150°C		Tensile strength 13.8 MPa minimum Ultimate elongation 300% minimum
Low Temperature Flexibility 4hrs at -65°C	IEC 62329-2	No cracking
Flammability	IEC 62329-2	Time of burning <60secs Length of burning <25mm
Water Absorbtion 24hrs at 23°C	IEC 623929-2	0.5% maximum
Electric Strength	IEC 62329-2	12 MV/m minimum
Volume Resistivity	IEC 62329-2	10 ¹² ohms cms minimum
Fungus Resistance	IEC 62329-1	<1
Fluid Resistance 24hrs immersion at 23°C Petrol, Diesel, Jet Fuel JP 8	IEC 62329-2	Tensile Strength > 7MPa Elongation > 250%
COMPATIBILITY TESTING		
Dynamic Shear Room temperature 100°C	IEC 62329-2	>300 N 15mm cable >30 N 15mm cable
Peel Adhesion Boot to Adaptor Boot to Cable	IEC 62329-2	>60N/25mm >60N/25mm

Material Qualifies to SC-X15111D

Listed in the NASA MAPTIS (Material and Process Technical Information System) database
 NASA MAPTIS Registered, material code 09720



SERIES 77
Heat Shrink Boots



Compound Material Specifications
Type 6 Material: 2051 Elastomer Polymer Alloy

A

GTS 4079: Heat-Shrinkable Elastomer Polymer Alloy (EPA)
Operating Temperature Range: -55°C to 135°C

This Material Specification establishes the quality standard for a heat-shrinkable EPA compound used to manufacture Glenair® molded components. All testing of molded shapes are specified in SCD7090. All testing to be carried out on molded sheets 2mm thick unless otherwise specified. For system tests size S06 boots with type 779-001 two-part epoxy adhesive with 25mm aluminum backshells and 15mm Neoprene jacketed cable shall be used.

Installation Temperature: Minimum 135°C, Recovered 150°C

Compound 2051 Type 6 - Materials Specification		
Test	Test Procedure	Test Requirement
Visual Examination		Homogenous and essentially free from pinholes, bubbles, flaws, cracks and inclusions, color is black
Tensile Strength	IEC 62329-2	10.3 MPa minimum
Ultimate Elongation	IEC 62329-2	300% minimum
Hardness	IEC 62329-2	85 ±10 Shore A
Stiffness	ASTM D747	<40MPa
Specific Gravity	IEC 62329-2	<1.5
Heat Shock 4hrs at 225°C	IEC 62329-2	No dripping or flow Helical bend 20mm diameter, no cracking Tensile Strength 13.8 MPa minimum Ultimate Elongation 300% minimum
Heat Aging 168hrs at 100°C	IEC 62329-2	Tensile strength 10.3 MPa minimum Ultimate elongation 300% minimum
Low Temperature Flexibility 4hrs at -65°C	IEC 62329-2	No cracking
Flammability	IEC 62329-2	Time of burning < 60secs Length of burning < 25mm
Water Absorption 24hrs at 23°C	IEC 62329-2	0.5% maximum
Electric Strength	IEC 62329-2	12 MV/m minimum
Volume Resistivity	IEC 62329-2	10 ¹² ohms cms minimum
Fungus Resistance	IEC 62329-1	<1
Fluid Resistance 24hrs Immersion at 23°C Petrol, Diesel, Jet Fuel JP8	IEC 62329-2	Tensile Strength > 7 MPa Elongation > 250%
COMPATIBILITY TESTING		
Dynamic Shear Room Temperature 100°C	IEC 62329-2	>300 N 15mm cable >30N 15mm cable
Peel Adhesion Boot to Adaptor Boot to Cable	IEC 62329-2	>60N/25mm >60N/25mm

Glenair 2051 material meets the requirements of SC-X15112C
 Listed in the NASA MAPTIS (Material and Process Technical Information System) database



SERIES 77
Heat Shrink Boots



Compound Material Performance Specifications
Type 7 Material: 2071 Semi-Rigid Polyolefin

GTS 4080: Heat-Shrinkable Semi-Rigid Polyolefin
Operating Temperature Range: -55°C to 135°C

This Quality Assurance Specification establishes the quality standard for a heat-shrinkable compound used to manufacture Glenair® molded components. Dimensions of molded shapes are specified in SCD7090. All testing to be carried out on molded sheets 2mm thick unless otherwise specified. For system test size S06 boots with type W1 adhesive with 25mm aluminum backshells and 15mm CRNF-100 jacketed cable shall be used.

Installation Temperature: Minimum 120°C, Recovered 150°C



Compound 2071 Type 7 - Materials Specification		
Test	Test Procedure	Test Requirement
Visual Examination		Homogenous and essentially free from pinholes, bubbles, flaws, cracks and inclusions, color is black
Tensile Strength	IEC 62329-2	10.3 MPa minimum
Ultimate Elongation	IEC 62329-2	250% minimum
Hardness	IEC 62329-2	80 ±10 Shore A
Stiffness	ASTM D747	<80MPa
Specific Gravity	IEC 62329-2	<1.3
Heat Shock 4hrs at 250°C	IEC 62329-2	No dripping or flow Helical bend 20mm diameter, no cracking Tensile Strength 6.9 MPa minimum Ultimate Elongation 200% minimum
Heat Aging 168hrs at 175°C	IEC 62329-2	Tensile strength 6.9 MPa minimum Ultimate elongation 200% minimum
Low Temperature Flexibility 4hrs at -55°C	IEC 62329-2	No cracking
Flammability	IEC 62329-2	Time of burning < 60secs Length of burning < 25mm
Water Absorption 24hrs at 23°C	IEC 62329-2	0.5% maximum
Electric Strength	IEC 62329-2	8 MV/m minimum
Volume Resistivity	IEC 62329-2	10 ¹² ohms cms minimum
Fungus Resistance	IEC 62329-1	<1
FLUID RESISTANCE 24hr Immersion at 23° C Petrol F-67, JP-5, F-34, Skydrol 500 Diesel F-75, Cleaning Fluid Deicing Fluid, 5% Salt Solution Lubricating Oils 0-156, O-236 Hydraulic Fluid H-542	IEC 62329-2	Tensile Strength > 6 MPa Elongation > 200% Test after 1 hour of removal from fluid Weight Uptake < 20%
COMPATIBILITY TESTING		
Dynamic Shear Room Temperature 100°C	IEC 62329-2	>300 N 15mm cable >30N 15mm cable
Peel Adhesion Boot to Adaptor Boot to Cable	IEC 62329-2	>60N/25mm >60N/25mm

Glenair 2071 material meets the requirements of AS5258 Material A and SC-X15112C



SERIES 77
Heat Shrink Boots



Compound Material Specifications
Type 8 Material: 2008 Space Grade, Low Outgassing

A

GTS 4123: Heat-Shrinkable, Space Grade, Fluoropolymer Alloy
Operating Temperature Range: -50°C to 175°C

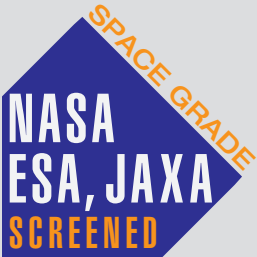

This Material Specification establishes the quality standard for a heat-shrinkable compound used to manufacture Glenair® molded components. These components meet the low out-gassing NASA TML and CVCM outgassing requirements and area suitable for high altitude and space applications. Dimensions of molded shapes are specified in the relevant SCD. All testing to be carried out on molded sheets 2mm thick unless otherwise specified. Recommended adhesive for Type 8 is the two-part epoxy Glenair 779-001.

Installation Temperature: Minimum 135°C, Recovered 175°C

Compound 2008 Type 8 - Materials Specification		
Test	Test Procedure	Test Requirement
Visual Examination		Homogenous and essentially free from pinholes, bubbles, flaws, cracks and inclusions, color is black
Tensile Strength	IEC 62329-2	12 MPa minimum
Ultimate Elongation	IEC 62329-2	300% minimum
2% Secant Modulus	IEC 62329-2	100-125MPa
Specific Gravity	IEC 62329-2	<1.4
Heat Shock 4hrs at 225°C	IEC 62329-2	No dripping or cracking
Heat Aging 168hrs at 175°C	IEC 62329-2	Tensile strength 10.0 MPa minimum Ultimate elongation 200% minimum No Dripping, flow or cracking
Low Temperature Flexibility 4hrs at -50°C	MIL-DTL-85049	No cracking
Flammability	IEC 62329-2	Time of burning < 60secs Length of burning <25mm
Water Absorption 24hrs at 23°C	IEC 62329-2	0.5% maximum
Electric Strength	IEC 62329-2	8 MV/m minimum
Volume Resistivity	IEC 62329-2	10 ¹² ohms cms minimum
Outgassing	ASTM E595	CVCM <0.1% TML <1%

Listed in the NASA MAPTIS (Material and Process Technical Information System) database
NASA MAPTIS Registered, material code 09719



SERIES 77
Heat Shrink Boots



Compound Material Specifications
Type 9 Material: Low-Temp Polyolefin

GTS 4086: Low Temperature Installable, Heat-Shrinkable Flexible Polyolefin
Operating Temperature Range: -40°C to 100°C

This Material Specification establishes the quality standard for a heat-shrinkable flexible polyolefin compound used to manufacture Glenair® molded components. All testing to be carried out on molded sheets 2mm thick unless otherwise specified. For system tests size S06 boots with 25mm aluminum backshells and 10mm RNF 100 (Raychem) jacketed cable shall be used. Type W2 adhesive shall be used.

Installation Temperature: Minimum 70°C, Recovered 100°C

A

Compound 2013 Type 9 - Materials Specification		
Test	Test Procedure	Test Requirement
Visual Examination		Homogenous and essentially free from pinholes, bubbles, flaws, cracks and inclusions, colour is black
Tensile Strength	IEC 62329-2	12Mpa minimum
Ultimate Elongation	IEC 62329-2	500% minimum
2% Secant Modulus	IEC 62329-2	20-30 MPa
Hardness Shore A		75-85
Specific Gravity	IEC 62329-2	1.3 Max
Heat Shock 4hrs at 150°C	IEC 62329-2	No dripping or flow Tensile Strength 8 MPa minimum Ultimate Elongation 200% minimum
Heat Ageing 168hrs at 150°C	IEC 62329-2	Tensile Strength 8 MPa minimum Ultimate Elongation 200 % minimum
Low temperature Flexibility 4hrs at -40°C	IEC 62329-2	No Cracking
Flammability	IEC 62329-2	Time of burning < 120secs Length of burning < 25mm
Water Absorption 24hrs at 23°C	IEC 62329-2	0.5% maximum
Electric Strength	IEC 62329-2	10 MV/m minimum
Volume Resistivity	IEC 62329-2	10 ¹⁰ ohms cms minimum
Copper Mirror Corrosion 16hrs @ 150	IEC 62329-2	No Corrosion
Storage Temperature		All parts stored below 40°C before use
Dimensional Stability 14 days at 40°C	IEC 62329-2	Measured dimensional values both expanded and recovered in specification

SERIES 77
AS85049 BOOTS
AND TRANSITIONS

AS85049

AS85049 shrink boots available for
AS85049/140, /141 and /142.



Glenair AS85049 heat shrink boots are available in /140 and /141 in standard material offerings including polyolefin (2071), general purpose polyolefin (2040), zero halogen polyolefin (2010), and high performance elastomer (2025). Boot styles include straight and right angle boots in standard and miniature low profiles. Boots can be ordered with zero halogen hot melt adhesive rated for operation at up to 120°C. For higher performance applications epoxy precoat (R) is also available for elastomer shrink boots (2025), epoxy adhesive is required for higher operating temperatures of 150°C. Boots can also be ordered without adhesive for user application of adhesive. Additionally AS85049/142 cable management style transitions – Wye, Tee and Multi-Leg, are also available with the same material and adhesive options. Contact Glenair for innovative shrink boot adapters and piggy back boots designed to speed up your installation process.



Glenair, Inc.
1211 Air Way
Glendale, CA 91201-2497
818-247-6000
sales@glenair.com
www.glenair.com



SERIES 77
AS85049 Boots



M85049 Heat Shrink Boot



M85049/140 Straight Boots

Straight.....	B-2
Straight, Low Profile.....	B-4
Straight, Low Profile Miniature.....	B-6
Straight, Sealing.....	B-8

B



M85049/141 Right Angle Boots

Right Angle.....	B-10
Right Angle, Low Profile.....	B-12
Right Angle, Low Profile Miniature.....	B-14



M85049/142 Transitions

Tee Transition, Wide Body.....	B-16
Wye Transition, Wide Body.....	B-18
1 to 3 Transition.....	B-20



SERIES 77
AS85049 Boots



M85049/140 Straight Heat Shrink Boot



AS85049 lipped, straight heat shrink boots provide mechanical and environmental protection from damage and debris. AS85049 straight boots are made in accordance with AS85049 and fit standard boot adapters for circular connectors. All adhesive lined and unlined shrink boots are RoHS compliant. Shrink boots are water-tight when equipped with factory installed or user-installed adhesive. Lipped boots lock into boot groove located on adapter and can be ordered with potting holes to fit your requirements. Choose boot size based on adapter diameter and cable diameter.

B

How to Order						
Sample Part Number	M85049/140	-05	H	C	D	P
Product Series	M85049/140 = straight AS85049 boot					
Dash No.	01, 02, 03, 04, 05, 06, 07, 08 ; see dimensions table					
Material	A, B, G, H ; See material table					
Adhesive Option	C = adhesive lined, see adhesive table U = no adhesive					
Drain Holes	D = drain holes Omit for none					
Injection-Vent Ports	P = injection-vent port Omit for none					

Material			
Material	Compound	Material Description	Color Code
A	2071	Polyolefin Semi-Rigid	White
B	2040	Polyolefin Flexible	Red
G	2010	Polyolefin	Green
H	2025	Elastomeric	Blue

Adhesive		
Code	Material	Description
C	Material A, G, H	-55° to +125°C Hot Melt adhesive
	Material B	-55° to +70°C Zero Halogen/Hot Melt
For applications exposed to temperatures reaching 150°C contact the factory		

NOTES

1. See bag identification for matching boot number, no number on boot. See part number development for full description
2. Encircled material letter designator located on O.D. approximately mid length along the 'J' end see part number development for full description
3. Recovered dimension apply to unrestricted recovery. Dimensions may differ than shown when boots are installed over assembly.



SERIES 77
AS85049 Boots



M85049/140 Straight Heat Shrink Boot

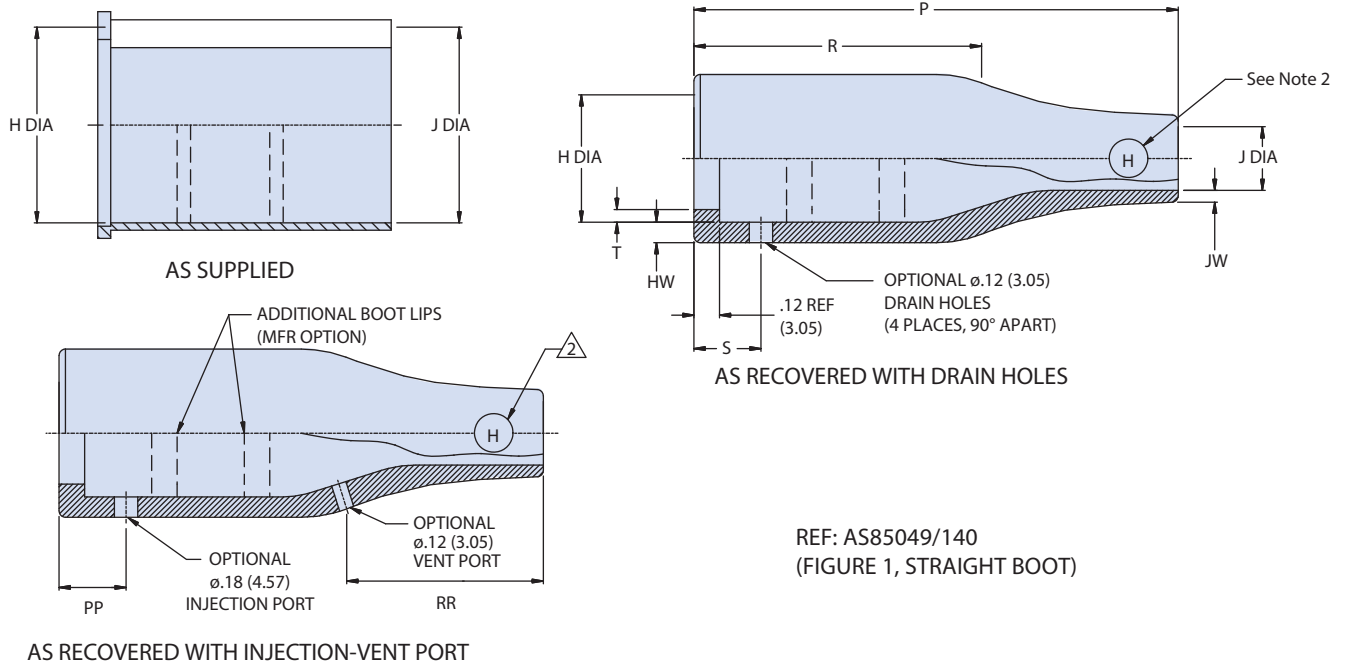

B

Dimensions													
Dash No See Note 1	H Dia* Min	H Dia** Max	J Dia* Min Material A,B,H	J Dia* Min Material G	J Dia** Max	P** ±10%	R** Ref	T** Ref	HW** ±20%	JW** Max	PP** ±10%	S** ±10%	RR** ±10%
01	0.92 (23.4)	0.41 (10.4)	0.92 (23.4)	0.47 (11.9)	0.24 (6.1)	1.50 (38.1)	0.83 (21.1)	0.04 (1.0)	0.07 (1.8)	0.09 (2.2)	0.60 (15.2)	0.48 (12.2)	N/A
02	1.12 (28.4)	0.56 (14.2)	1.12 (28.4)	0.58 (14.7)	0.26 (6.6)	2.16 (54.9)	1.09 (27.7)	0.04 (1.0)	0.07 (1.8)	0.09 (2.2)	0.60 (15.2)	0.49 (12.4)	.85 (21.6)
03	1.22 (31.0)	0.70 (17.8)	1.22 (31.0)	0.63 (16.0)	0.28 (7.1)	2.63 (66.8)	1.39 (35.3)	0.04 (1.0)	0.08 (2.0)	0.10 (2.5)	0.60 (15.2)	0.75 (19.1)	.96 (24.4)
04	1.42 (36.1)	0.88 (22.4)	1.42 (36.1)	0.73 (18.5)	0.38 (9.7)	3.15 (80.0)	1.63 (41.4)	0.04 (1.0)	0.08 (2.0)	0.10 (2.5)	0.60 (15.2)	0.75 (19.1)	1.17 (29.7)
05	1.68 (42.7)	1.11 (28.2)	1.68 (42.7)	0.87 (22.1)	0.39 (9.9)	4.08 (103.6)	2.22 (56.4)	0.07 (1.8)	0.09 (2.3)	0.11 (2.7)	0.60 (15.2)	0.75 (19.1)	1.44 (36.6)
06	2.04 (51.8)	1.38 (35.1)	2.04 (51.8)	1.39 (35.3)	0.63 (16.0)	5.13 (130.3)	2.54 (64.5)	0.07 (1.8)	0.13 (3.3)	0.16 (4.0)	0.60 (15.2)	0.57 (14.5)	2.12 (53.8)
07	2.60 (66.0)	1.75 (44.5)	2.60 (66.0)	1.80 (45.7)	0.80 (20.3)	6.50 (165.1)	3.31 (84.1)	0.08 (2.0)	0.16 (4.1)	0.19 (4.9)	0.60 (15.2)	0.68 (17.3)	2.59 (65.8)
08	3.22 (81.8)	2.27 (57.7)	3.22 (81.8)	2.25 (57.2)	1.00 (25.4)	7.00 (177.8)	3.75 (95.3)	0.08 (2.0)	0.16 (4.1)	0.19 (4.9)	0.60 (15.2)	0.68 (17.3)	2.64 (67.1)

*As Supplied **As Recovered



SERIES 77
AS85049 Boots



M85049/140 Straight, Low Profile Heat Shrink Boot



AS85049 lipped, straight low profile heat shrink boots provide mechanical and environmental protection from damage and debris. AS85049 straight boots are made in accordance with AS85049 and fit standard boot adapters for circular connectors. All adhesive lined and unlined shrink boots are RoHS compliant. Shrink boots are water-tight when equipped with factory installed or user-installed adhesive. Lipped boots lock into boot groove located on adapter and can be ordered with potting holes to fit your requirements. Choose boot size based on adapter diameter and cable diameter.

B

How to Order						
Sample Part Number	M85049/140	-09	H	C	D	P
Product Series	M85049/140 = straight low profile AS85049 boot					
Dash No.	09, 10, 11, 12, 13, 14, 15, 16, 17, 18; see dimension table					
Material	A, B, G, H; see material table					
Adhesive Option	C = adhesive lined, see adhesive table U = no adhesive					
Drain Holes	D = drain holes Omit for none					
Injection-Vent Ports	P = injection-vent port Omit for none					

Material			
Material	Compound	Material Description	Color Code
A	2071	Polyolefin Semi-Rigid	White
B	2040	Polyolefin Flexible	Red
G	2010	Polyolefin	Green
H	2025	Elastomeric	Blue

Adhesive		
Code	Material	Description
C	Material A, G, H	-55° to +125°C Hot Melt adhesive
	Material B	-55° to +70°C Zero Halogen/Hot Melt
For applications exposed to temperatures reaching 150°C contact the factory		

NOTES

1. See bag identification for matching boot number, no number on boot. See part number development for full description
2. Encircled material letter designator located on O.D. approximately mid length along the 'J' end see part number development for full description
3. Recovered dimension apply to unrestricted recovery. Dimensions may differ than shown when boots are installed over assembly.



SERIES 77
AS85049 Boots



M85049/140 Straight, Low Profile Heat Shrink Boot

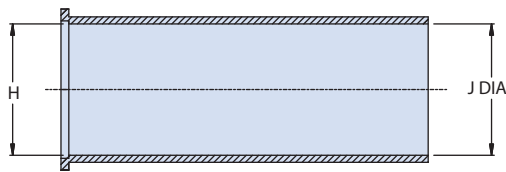

AS SUPPLIED

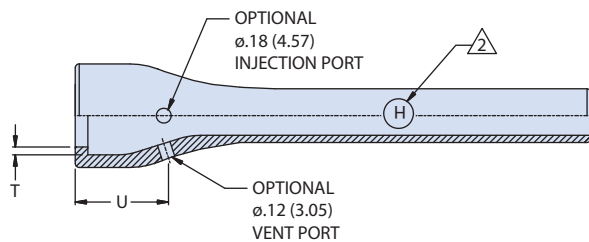

AS RECOVERED WITH INJECTION-VENT PORT

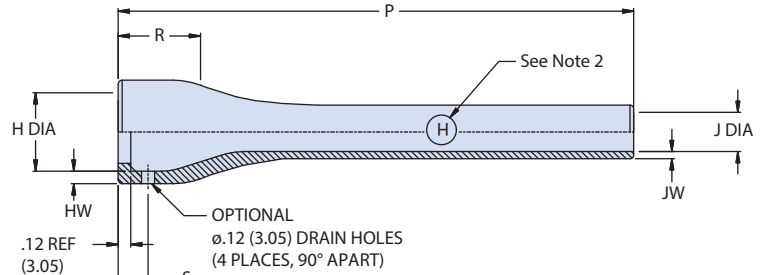

AS RECOVERED WITH DRAIN HOLES

REF: AS85049/140
(FIGURE 2, STRAIGHT, LOW PROFILE)

B

Dimensions

Dash No See Note 1	H Dia* Min	H Dia** Max	J Dia* Min Material A,B,H	J Dia** Min Material G	J Dia Max**	P** ±10%	R** Ref	T** Ref	HW** ±20%	JW** Max	S** ±10%	U** ±10% See Note 4
09	0.88 (22.4)	0.47 (11.9)	0.88 (22.4)	0.55 (14.0)	0.25 (6.4)	4.17 (105.9)	0.46 (11.7)	0.04 (1.0)	0.06 (1.5)	0.05 (1.1)	0.23 (5.8)	0.56 (14.2)
10	0.98 (24.9)	0.59 (15.0)	0.98 (24.9)	0.63 (16.0)	0.30 (7.6)	4.77 (121.2)	0.48 (12.2)	0.04 (1.0)	0.06 (1.5)	0.05 (1.1)	0.24 (6.1)	0.59 (15.0)
11	1.16 (29.5)	0.75 (19.1)	1.16 (29.5)	0.72 (18.3)	0.33 (8.4)	5.46 (138.7)	0.48 (12.2)	0.04 (1.0)	0.07 (1.8)	0.05 (1.1)	0.47 (11.9)	0.61 (15.5)
12	1.34 (34.0)	0.91 (23.1)	1.34 (34.0)	0.84 (21.3)	0.39 (9.9)	6.28 (159.5)	0.48 (12.2)	0.04 (1.0)	0.07 (1.8)	0.05 (1.1)	0.47 (11.9)	0.62 (15.7)
13	1.47 (37.3)	1.18 (30.0)	1.47 (37.3)	0.91 (23.1)	0.43 (10.9)	7.00 (177.8)	0.55 (14.0)	0.07 (1.7)	0.08 (2.0)	0.05 (1.1)	0.47 (11.9)	0.71 (18.0)
14	1.72 (43.7)	1.34 (34.0)	1.72 (43.7)	1.07 (27.2)	0.48 (12.2)	8.00 (203.2)	0.60 (15.2)	0.07 (1.7)	0.08 (2.0)	0.05 (1.1)	0.47 (11.9)	0.78 (19.8)
15	1.97 (50.0)	1.62 (41.1)	1.97 (50.0)	1.24 (31.5)	0.57 (14.5)	8.00 (203.2)	0.60 (15.2)	0.07 (1.7)	0.09 (2.3)	0.06 (1.5)	0.30 (7.6)	0.82 (20.8)
16	2.47 (62.7)	1.85 (47.0)	2.47 (62.7)	1.54 (39.1)	0.71 (18.0)	8.00 (203.2)	0.63 (16.0)	0.08 (2.0)	0.10 (2.5)	0.06 (1.5)	0.63 (16.0)	0.92 (23.4)
17	2.73 (69.3)	2.36 (59.9)	2.73 (69.3)	1.70 (43.2)	0.79 (20.1)	8.00 (203.2)	0.63 (16.0)	0.08 (2.0)	0.10 (2.5)	0.06 (1.5)	0.63 (16.0)	0.93 (23.6)
18	3.22 (81.8)	2.64 (67.1)	3.22 (81.8)	2.01 (51.1)	0.91 (23.1)	8.00 (203.2)	0.63 (16.0)	0.08 (2.0)	0.10 (2.5)	0.06 (1.5)	0.63 (16.0)	1.23 (31.2)

*As Supplied **As Recovered



SERIES 77
AS85049 Boots



M85049/140 Straight Low Profile Miniature Heat Shrink Boot

B



AS85049 lipped, straight low profile miniature heat shrink boots provide mechanical and environmental protection from damage and debris. AS85049 straight boots are made in accordance with AS85049 and fit standard boot adapters for circular connectors. All adhesive lined and unlined shrink boots are RoHS compliant. Shrink boots are water-tight when equipped with factory installed or user-installed adhesive. Lipped boots lock into boot groove located on adapter and can be ordered with potting holes to fit your requirements. Choose boot size based on adapter diameter and cable diameter.

How to Order						
Sample Part Number	M85049/140	-20	H	C	D	P
Product Series	M85049/140 = straight low profile miniature AS85049 boot					
Dash No.	19, 20, 21, 22; see dimension table					
Material	A, B, G, H; see material table					
Adhesive Option	C = adhesive lined, see adhesive table U = no adhesive					
Drain Holes	D = drain holes Omit for none					
Injection-Vent Ports	P = injection-vent port Omit for none					

Material			
Material	Compound	Material Description	Color Code
A	2071	Polyolefin Semi-Rigid	White
B	2040	Polyolefin Flexible	Red
G	2010	Polyolefin	Green
H	2025	Elastomeric	Blue

Adhesive		
Code	Material	Description
C	Material A, G, H	-55° to +125°C Hot Melt adhesive
	Material B	-55° to +70°C Zero Halogen/Hot Melt
For applications exposed to temperatures reaching 150°C contact the factory		

NOTES

1. See bag identification for matching boot number, no number on boot. See part number development for full description
2. Encircled material letter designator located on O.D. approximately mid length along the 'J' end see part number development for full description
3. Recovered dimension apply to unrestricted recovery. Dimensions may differ than shown when boots are installed over assembly.



SERIES 77
AS85049 Boots



M85049/140 Straight Low Profile Miniature Heat Shrink Boot

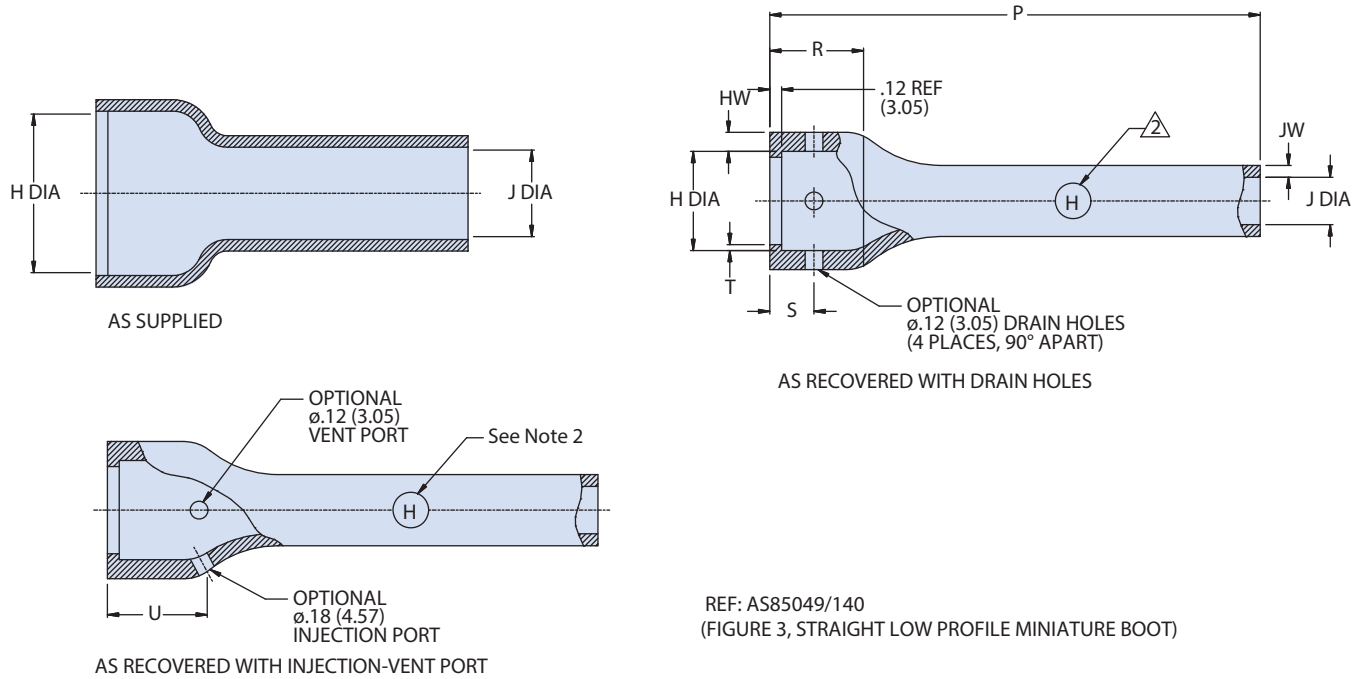

B

Dimensions												
Dash No. See Note 1	H Dia Min*	H Dia Max**	J Dia Min* Matl A,B,H	J Dia Min* Matl G	J Dia Max**	P** ±10%	R** ±10%	T** ±10%	HW** ±20%	JW Max**	S** ±10%	U** ±10% See Note 4
19	0.76 (19.3)	0.51 (13.0)	0.25 (6.4)	0.18 (4.6)	0.08 (2.0)	2.37 (60.2)	0.46 (11.7)	0.04 (1.0)	0.06 (1.5)	0.05 (1.14)	0.47 (11.9)	0.62 (15.75)
20	1.03 (26.2)	0.75 (19.1)	0.30 (7.6)	0.22 (5.6)	0.10 (2.5)	2.92 (74.2)	0.48 (12.2)	0.04 (1.0)	0.07 (1.8)	0.05 (1.14)	0.47 (11.9)	0.80 (20.32)
21	1.35 (34.3)	1.02 (25.9)	0.38 (9.7)	0.26 (6.6)	0.12 (3.0)	3.32 (84.3)	0.48 (12.2)	0.04 (1.0)	0.07 (1.8)	0.05 (1.14)	0.47 (11.9)	0.90 (22.86)
22	1.72 (43.7)	1.34 (34.0)	0.45 (11.4)	0.31 (7.9)	0.14 (3.6)	3.92 (99.6)	0.48 (12.2)	0.07 (1.7)	0.07 (1.8)	0.05 (1.14)	0.47 (11.9)	1.03 (26.16)

*As Supplied **As Recovered



SERIES 77
AS85049 Boots



M85049/140 Straight Sealing Heat Shrink Boot



AS85049 lipped, straight sealing shrink boots provide mechanical and environmental protection from damage and debris. AS85049 straight boots are made in accordance with AS85049 and fit standard boot adapters for circular connectors. All adhesive lined and unlined shrink boots are RoHS compliant. Shrink boots are water-tight when equipped with factory installed or user-installed adhesive. Lipped boots lock into boot groove located on adapter and can be ordered with potting holes to fit your requirements. Choose boot size based on adapter diameter and cable diameter.

B

How to Order					
Sample Part Number		M85049/140	-25	H	C
Product Series	M85049/140 = straight sealing AS85049 boot				
Dash No.	23, 24, 25, 26, 27, 28 ; see dimension table				
Material	A, B, G, H ; see material table				
Adhesive Option	C = adhesive lined, see adhesive table U = no adhesive				

Material			
Material	Compound	Material Description	Color Code
A	2071	Polyolefin Semi-Rigid	White
B	2040	Polyolefin Flexible	Red
G	2010	Polyolefin	Green
H	2025	Elastomeric	Blue

Adhesive		
Code	Material	Description
C	Material A, G, H	-55° to +125°C Hot Melt adhesive
	Material B	-55° to +70°C Zero Halogen/Hot Melt
For applications exposed to temperatures reaching 150°C contact the factory		

NOTES

1. See bag identification for matching boot number, no number on boot. See part number development for full description
2. Encircled material letter designator located on O.D. approximately mid length along the 'J' end see part number development for full description
3. Recovered dimension apply to unrestricted recovery. Dimensions may differ than shown when boots are installed over assembly.



SERIES 77
AS85049 Boots



M85049/140 Straight Sealing Heat Shrink Boot

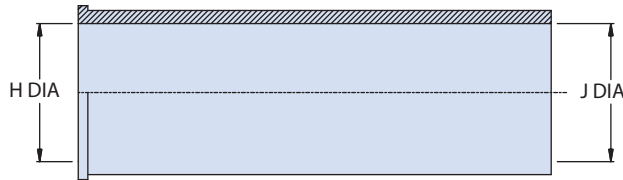

AS SUPPLIED

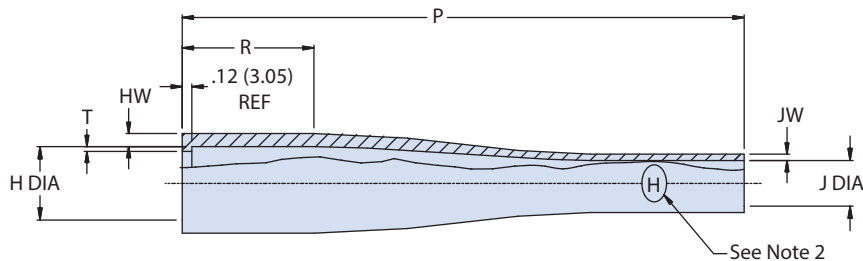

AS RECOVERED

REF: AS85049/140
(FIG.4 STRAIGHT SEALING BOOT)

B

Dimensions									
DASH NO 1	H DIA MIN*	H DIA MAX**	J DIA MIN*	J DIA MAX**	P** ±10%	R** ±10%	T** ±10%	HW** ±20%	JW MAX**
23	0.84 (21.3)	0.55 (14.0)	0.66 (16.8)	0.21 (5.3)	5.30 (134.6)	1.10 (27.9)	0.06 (1.5)	0.16 (4.1)	0.04 (1.0)
24	1.00 (25.4)	0.65 (16.5)	1.00 (25.4)	0.33 (8.4)	6.00 (152.4)	1.20 (30.5)	0.06 (1.5)	0.16 (4.1)	0.06 (1.5)
25	1.30 (33.0)	0.80 (20.3)	1.30 (33.0)	0.43 (10.9)	6.00 (152.4)	1.20 (30.5)	0.06 (1.5)	0.16 (4.1)	0.06 (1.5)
26	1.70 (43.2)	0.90 (22.9)	1.70 (43.2)	0.56 (14.2)	6.90 (175.3)	1.50 (38.1)	0.06 (1.5)	0.16 (4.1)	0.08 (2.0)
27	2.10 (53.3)	1.10 (27.9)	2.10 (53.3)	0.70 (17.8)	6.90 (175.3)	1.50 (38.1)	0.06 (1.5)	0.16 (4.1)	0.08 (2.0)
28	2.85 (72.4)	1.45 (36.8)	2.85 (72.4)	0.95 (24.1)	7.24 (183.9)	1.60 (40.6)	0.06 (1.5)	0.20 (5.1)	0.10 (2.54)

*As Supplied **As Recovered



SERIES 77
AS85049 Boots



M85049/141 Right Angle Heat Shrink Boot



AS85049 lipped, right angle heat shrink boots provide mechanical and environmental protection from damage and debris. AS85049 straight boots are made in accordance with AS85049 and fit standard boot adapters for circular connectors. All adhesive lined and unlined shrink boots are RoHS compliant. Shrink boots are water-tight when equipped with factory installed or user-installed adhesive. Lipped boots lock into boot groove located on adapter and can be ordered with potting holes to fit your requirements. Choose boot size based on adapter diameter and cable diameter.

B

How to Order						
Sample Part Number	M85049/141	-03	H	C	D	P
Product Series	M85049/141 = right angle AS85049 boot					
Dash No.	01, 02, 03, 04, 05, 06, 07, 08; see dimension table					
Material	A, B, G, H; see material table					
Adhesive Option	C = adhesive lined, see adhesive table U = no adhesive					
Drain Holes	D = drain holes Omit for none					
Injection-Vent Ports	P = injection-vent port Omit for none					

Material			
Material	Compound	Material Description	Color Code
A	2071	Polyolefin Semi-Rigid	White
B	2040	Polyolefin Flexible	Red
G	2010	Polyolefin	Green
H	2025	Elastomeric	Blue

Adhesive		
Code	Material	Description
C	Material A, G, H	-55° to +125°C Hot Melt adhesive
	Material B	-55° to +70°C Zero Halogen/Hot Melt
For applications exposed to temperatures reaching 150°C contact the factory		

NOTES

1. See bag identification for matching boot number, no number on boot. See part number development for full description
2. Encircled material letter designator located on O.D. approximately mid length along the 'J' end see part number development for full description
3. Recovered dimension apply to unrestricted recovery. Dimensions may differ than shown when boots are installed over assembly.



SERIES 77
AS85049 Boots



M85049/141 Right Angle Heat Shrink Boot

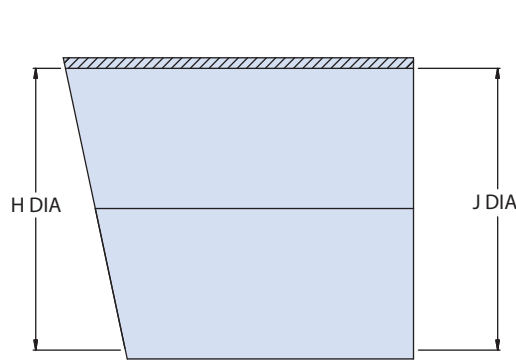

AS SUPPLIED

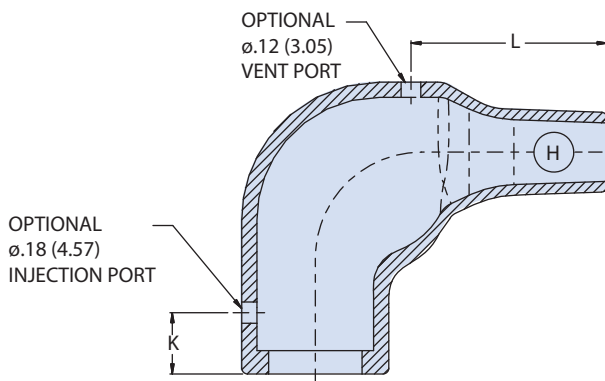

AS RECOVERED WITH INJECTION-VENT PORT

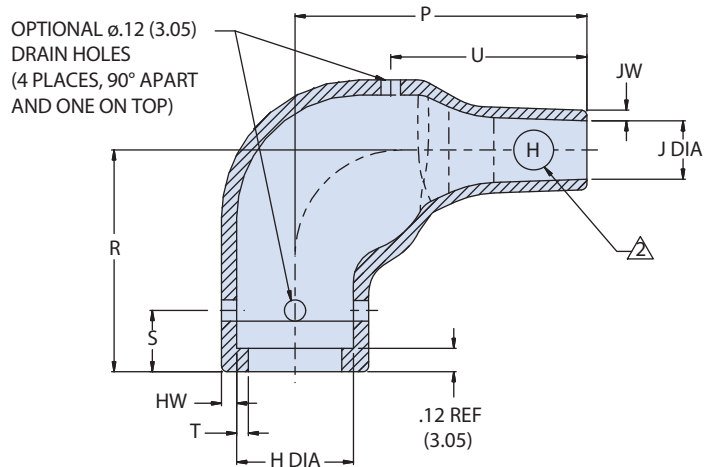

AS RECOVERED WITH DRAIN HOLES

REF: AS85049/141
(FIG. 1- RIGHT ANGLE BOOT)

B

Dimensions														
Dash No See Note 1	H Dia Min*	H Dia Max**	J Dia Min* Material A,B,H	J Dia Min* Material G	J Dia Max**	P** ±10%	R** Ref	T** Ref	HW** ±20%	JW Max**	S** ±10%	U** ±10%	K** ±10%	L** ±10%
01	0.92 (23.4)	0.41 (10.4)	0.92 (23.4)	0.47 (11.9)	0.24 (6.1)	0.84 (21.3)	0.65 (16.5)	0.04 (1.0)	0.05 (1.3)	0.05 (1.3)	0.45 (11.4)	0.47 (11.9)	0.60 (15.2)	0.58 (14.7)
02	1.12 (28.4)	0.61 (15.5)	1.12 (28.4)	0.58 (14.7)	0.26 (6.6)	1.33 (33.8)	0.76 (19.3)	0.04 (1.0)	0.06 (1.5)	0.05 (1.3)	0.47 (11.9)	1.02 (25.9)	0.75 (19.1)	0.98 (24.9)
03	1.22 (31.0)	0.71 (18.0)	1.22 (31.0)	0.63 (16.0)	0.28 (7.1)	1.44 (36.6)	0.83 (21.1)	0.04 (1.0)	0.07 (1.8)	0.07 (1.8)	0.47 (11.9)	1.09 (27.7)	0.75 (19.1)	0.98 (24.9)
04	1.42 (36.1)	0.89 (22.6)	1.42 (36.1)	0.73 (18.5)	0.33 (8.4)	1.72 (43.7)	0.90 (22.9)	0.04 (1.0)	0.07 (1.8)	0.07 (1.8)	0.47 (11.9)	1.16 (29.5)	0.75 (19.1)	1.18 (30.0)
05	1.68 (42.7)	1.12 (28.4)	1.68 (42.7)	0.87 (22.1)	0.39 (9.9)	2.11 (53.6)	1.14 (29.0)	0.07 (1.8)	0.08 (2.0)	0.08 (2.0)	0.47 (11.9)	1.47 (37.3)	0.76 (19.3)	1.30 (33.0)
06	2.04 (51.8)	1.38 (35.1)	2.04 (51.8)	1.39 (35.3)	0.63 (16.0)	3.07 (78.0)	1.32 (33.5)	0.07 (1.8)	0.13 (3.3)	0.13 (3.3)	0.53 (13.5)	2.50 (63.5)	1.00 (25.4)	2.12 (53.8)
07	2.60 (66.0)	1.77 (45.0)	2.60 (66.0)	1.80 (45.7)	0.80 (20.3)	3.84 (97.5)	1.64 (41.7)	0.08 (2.0)	0.15 (3.8)	0.15 (3.8)	0.64 (16.3)	2.75 (69.9)	1.00 (25.4)	2.80 (71.1)
08	3.22 (81.8)	2.40 (61.0)	3.22 (81.8)	2.25 (57.2)	1.00 (25.4)	4.64 (117.9)	2.03 (51.6)	0.08 (2.0)	0.16 (4.1)	0.16 (4.1)	0.64 (16.3)	3.12 (79.2)	1.00 (25.4)	3.15 (80.0)

*As Supplied **As Recovered



SERIES 77
AS85049 Boots



M85049/141 Right Angle,
Low Profile Heat Shrink Boot

B



AS85049 lipped, right angle low profile shrink boots provide mechanical and environmental protection from damage and debris. AS85049 right angle boots are made in accordance with AS85049 and fit standard boot adapters for circular connectors. All adhesive lined and unlined shrink boots are RoHS compliant. Shrink boots are water-tight when equipped with factory installed or user-installed adhesive. Lipped boots lock into boot groove located on adapter and can be ordered with potting holes to fit your requirements. Choose boot size based on adapter diameter and cable diameter.

How to Order						
Sample Part Number	M85049/141	-10	H	C	D	P
Product Series	M85049/141 = right angle, low profile AS85049 boot					
Dash No.	09, 10, 11, 12, 13, 14, 15, 16, 17, 18; see dimension table					
Material	A, B, G, H; see material table					
Adhesive Option	C = adhesive lined, see adhesive table U = no adhesive					
Drain Holes	D = drain holes Omit for none					
Injection-Vent Ports	P = injection-vent port Omit for none					

Material			
Material	Compound	Material Description	Color Code
A	2071	Polyolefin Semi-Rigid	White
B	2040	Polyolefin Flexible	Red
G	2010	Polyolefin	Green
H	2025	Elastomeric	Blue

Adhesive		
Code	Material	Description
C	Material A, G, H	-55° to +125°C Hot Melt adhesive
	Material B	-55° to +70°C Zero Halogen/Hot Melt
For applications exposed to temperatures reaching 150°C contact the factory		

NOTES

1. See bag identification for matching boot number, no number on boot. See part number development for full description
2. Encircled material letter designator located on O.D. approximately mid length along the 'J' end see part number development for full description
3. Recovered dimension apply to unrestricted recovery. Dimensions may differ than shown when boots are installed over assembly.



SERIES 77
AS85049 Boots



M85049/141 Right Angle,
Low Profile Heat Shrink Boot

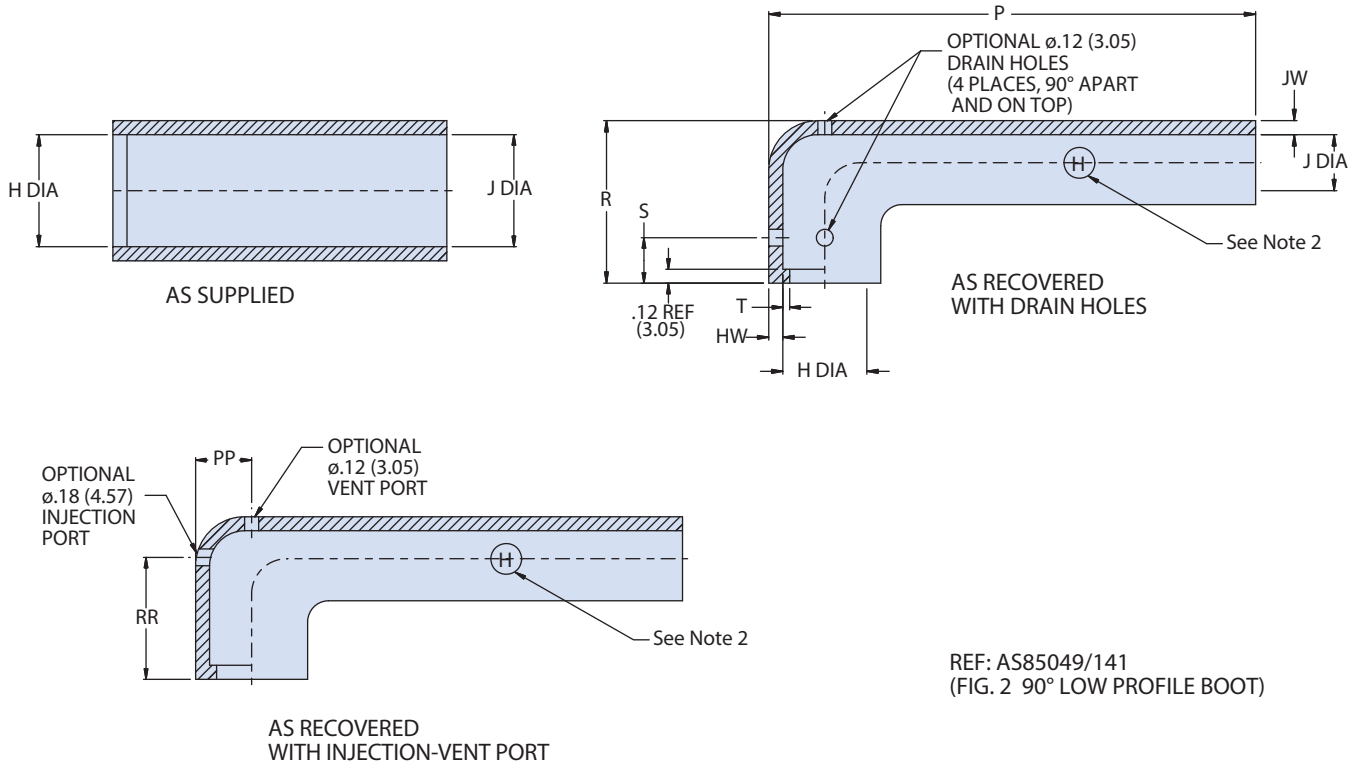

REF: AS85049/141
(FIG. 2 90° LOW PROFILE BOOT)

Dimensions													
Dash No. 1	H Dia Min*	H Dia Max**	J Dia Min* Material A,B,H	J Dia Max* Material G	J Dia Max**	P** ±10%	R** Ref	T** Ref	HW** ±20%	JW Max**	S** ±10%	PP** ±10%	RR** ±10%
09	0.88 (22.4)	0.45 (11.4)	0.88 (22.4)	0.55 (14.0)	0.25 (6.4)	4.14 (105.2)	0.73 (18.5)	0.04 (1.0)	0.06 (1.5)	0.06 (1.5)	0.47 (11.9)	0.27 (6.9)	0.49 (12.4)
10	1.01 (25.7)	0.59 (15.0)	1.01 (25.7)	0.63 (16.0)	0.30 (7.6)	4.88 (124.0)	0.78 (19.8)	0.04 (1.0)	0.06 (1.5)	0.06 (1.5)	0.47 (11.9)	0.33 (8.4)	0.59 (15.0)
11	1.16 (29.5)	0.74 (18.8)	1.16 (29.5)	0.72 (18.3)	0.33 (8.4)	5.76 (146.3)	0.82 (20.8)	0.04 (1.0)	0.07 (1.8)	0.06 (1.5)	0.47 (11.9)	0.41 (10.4)	0.61 (15.5)
12	1.34 (34.0)	0.90 (22.9)	1.34 (34.0)	0.84 (21.3)	0.39 (9.9)	6.78 (172.2)	0.86 (21.8)	0.04 (1.0)	0.07 (1.8)	0.06 (1.5)	0.47 (11.9)	0.48 (12.2)	0.62 (15.7)
13	1.47 (37.3)	1.16 (29.5)	1.47 (37.3)	0.91 (23.1)	0.43 (10.9)	7.29 (185.2)	0.96 (24.4)	0.07 (1.8)	0.08 (2.0)	0.06 (1.5)	0.47 (11.9)	0.61 (15.5)	0.70 (17.8)
14	1.72 (43.7)	1.34 (34.0)	1.72 (43.7)	1.07 (27.2)	0.48 (12.2)	8.41 (213.6)	1.08 (27.4)	0.07 (1.8)	0.08 (2.0)	0.06 (1.5)	0.47 (11.9)	0.72 (18.3)	0.78 (19.8)
15	1.97 (50.0)	1.62 (41.1)	1.97 (50.0)	1.24 (31.5)	0.57 (14.5)	8.84 (224.5)	1.16 (29.5)	0.07 (1.8)	0.09 (2.3)	0.06 (1.5)	0.47 (11.9)	0.83 (21.1)	0.82 (20.8)
16	2.47 (62.7)	1.85 (47.0)	2.47 (62.7)	1.54 (39.1)	0.71 (18.0)	8.95 (227.3)	1.31 (33.3)	0.08 (2.0)	0.10 (2.5)	0.06 (1.5)	0.63 (16.0)	0.95 (24.1)	0.92 (23.4)
17	2.73 (69.3)	2.35 (59.7)	2.73 (69.3)	1.70 (43.2)	0.79 (20.1)	9.19 (233.4)	1.38 (35.1)	0.08 (2.0)	0.10 (2.5)	0.06 (1.4)	0.63 (16.0)	1.18 (30.0)	0.93 (23.6)
18	3.22 (81.8)	2.64 (67.1)	3.22 (81.8)	2.01 (51.1)	0.91 (23.1)	9.33 (237.0)	1.75 (44.5)	0.08 (2.0)	0.10 (2.5)	0.06 (1.4)	0.63 (16.0)	1.31 (33.3)	1.23 (31.2)

*As Supplied **As Recovered



SERIES 77
AS85049 Boots



M85049/141 Right Angle,
Low Profile Miniature Heat Shrink Boot



AS85049 lipped, right angle low profile miniature heat shrink boots provide mechanical and environmental protection from damage and debris. AS85049 straight boots are made in accordance with AS85049 and fit standard boot adapters for circular connectors. All adhesive lined and unlined shrink boots are RoHS compliant. Shrink boots are water-tight when equipped with factory installed or user-installed adhesive. Lipped boots lock into boot groove located on adapter and can be ordered with potting holes to fit your requirements. Choose boot size based on adapter diameter and cable diameter.

B

How to Order	
Sample Part Number	M85049/141 -03 H C D P
Product Series	M85049/141 = right angle low profile miniature AS85049 boot
Dash No.	19, 20, 21, 22; see dimension table
Material	A, B, G, H; see material table
Adhesive Option	C = adhesive lined, see adhesive table U = no adhesive
Drain Holes	D = drain holes Omit for none
Injection-Vent Ports	P = injection-vent port Omit for none

Material			
Material	Compound	Material Description	Color Code
A	2071	Polyolefin Semi-Rigid	White
B	2040	Polyolefin Flexible	Red
G	2010	Polyolefin	Green
H	2025	Elastomeric	Blue

Adhesive		
Code	Material	Description
C	Material A, G, H	-55° to +125°C Hot Melt adhesive
	Material B	-55° to +70°C Zero Halogen/Hot Melt
For applications exposed to temperatures reaching 150°C contact the factory		

NOTES

1. See bag identification for matching boot number, no number on boot. See part number development for full description
2. Encircled material letter designator located on O.D. approximately mid length along the 'J' end see part number development for full description
3. Recovered dimension apply to unrestricted recovery. Dimensions may differ than shown when boots are installed over assembly.



SERIES 77
AS85049 Boots



M85049/141 Right Angle,
Low Profile Miniature Heat Shrink Boot

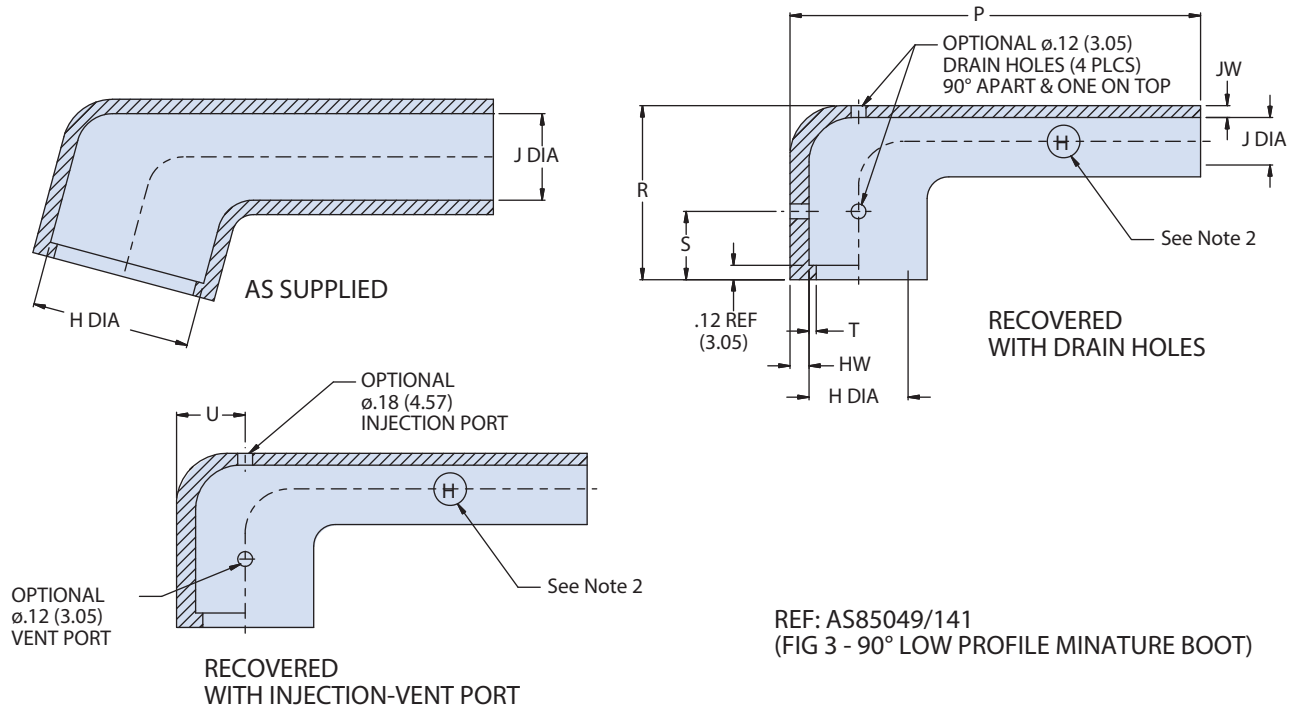

B

Dimensions												
Dash No. See Note 1	H Dia Min*	H Dia Max**	J Dia Min* Material A,B,H	J Dia Min* Material G	J Dia** Max	P** ±10	R** Ref	T** Ref	HW** ±20%	JW Max**	S** ±10%	U** ±10% 4
19	0.76 (19.3)	0.51 (13.0)	0.25 (6.4)	0.18 (4.6)	0.08 (2.0)	1.75 (44.5)	0.64 (16.3)	0.04 (1.0)	0.06 (1.5)	0.05 (1.1)	0.47 (11.9)	0.22 (5.6)
20	1.03 (26.2)	0.75 (19.1)	0.30 (7.6)	0.22 (5.6)	0.10 (2.5)	2.65 (67.3)	0.71 (18.0)	0.04 (1.0)	0.07 (1.8)	0.05 (1.1)	0.47 (11.9)	0.33 (8.4)
21	1.35 (34.3)	1.02 (25.9)	0.38 (9.7)	0.26 (6.6)	0.12 (3.0)	3.20 (81.3)	0.74 (18.8)	0.04 (1.0)	0.07 (1.8)	0.05 (1.1)	0.47 (11.9)	0.45 (11.4)
22	1.72 (43.7)	1.34 (34.0)	0.45 (11.4)	0.31 (7.9)	0.14 (3.6)	4.55 (115.6)	0.84 (21.3)	0.07 (1.8)	0.07 (1.8)	0.05 (1.1)	0.47 (11.9)	0.61 (15.5)

*As Supplied **As Recovered



SERIES 77
AS85049 Boots



M85049/142 Tee Transition, Wide Body



AS85049 wide body 'TEE' heat shrink transitions provide mechanical and environmental protection from damage and debris. AS85049 straight boots are made in accordance with AS85049. All adhesive lined and unlined transitions are RoHS compliant. Transitions are water-tight when equipped with factory installed or user-installed adhesive. Choose transition size based on cable diameter.

B

How to Order					
Sample Part Number	M85049/142	-02	H	C	P
Product Series	M85049/142 = wide body tee AS85049 transition				
Dash No.	01, 02, 03, 04; see dimension table				
Material	A, B, G, H; see material table				
Adhesive Option	C = adhesive lined, see adhesive table U = no adhesive				
Injection-Vent Ports	P = injection-vent port Omit for none				

Material			
Material	Compound	Material Description	Color Code
A	2071	Polyolefin Semi-Rigid	White
B	2040	Polyolefin Flexible	Red
G	2010	Polyolefin	Green
H	2025	Elastomeric	Blue

Adhesive		
Code	Material	Description
C	Material A, G, H	-55° to +125°C Hot Melt adhesive
	Material B	-55° to +70°C Zero Halogen/Hot Melt
For applications exposed to temperatures reaching 150°C contact the factory		

NOTES

1. See bag identification for matching boot number, no number on boot. See part number development for full description
2. Encircled material letter designator located on O.D. approximately mid length along the 'J' end see part number development for full description
3. Recovered dimension apply to unrestricted recovery. Dimensions may differ than shown when boots are installed over assembly.



SERIES 77
AS85049 Boots



M85049/142 Tee Transition, Wide Body

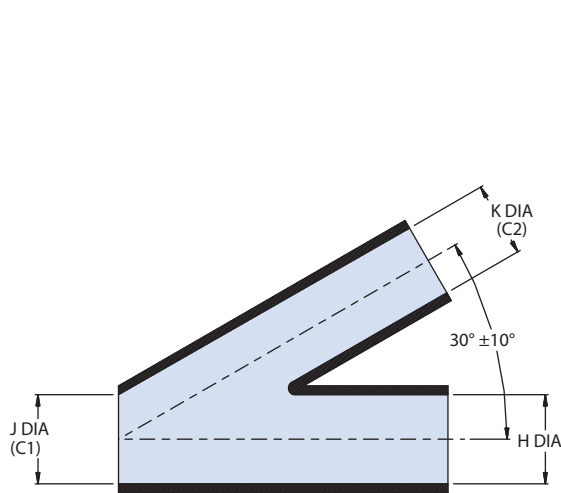

AS SUPPLIED

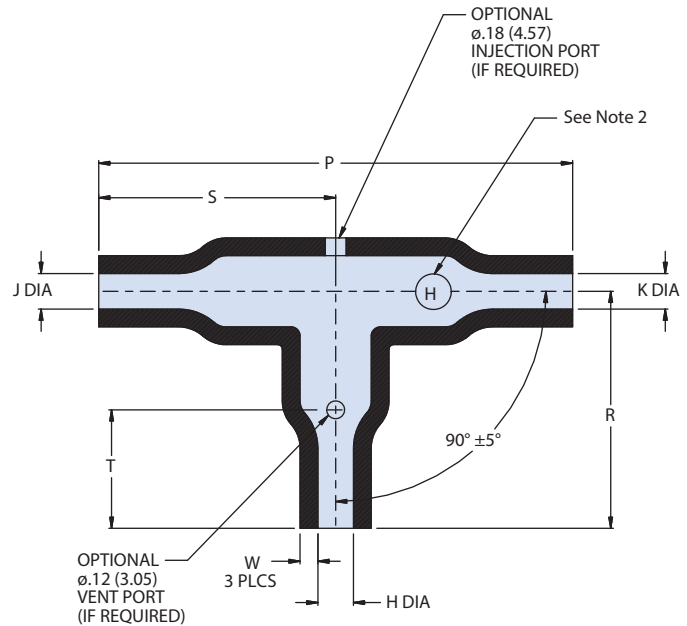

RECOVERED

REF: AS85049/142
(FIG.1 T TYPE BOOT)

B

Dimensions							
DASH NO.	H,J,K DIA MIN*	H,J,K DIA MAX**	P**	R**	S**	T**	W**
1			±10%	±10%	±10%	±10%	±20%
01	.26 (6.6)	.14 (3.6)	1.17 (29.7)	0.58 (14.7)	0.59 (15.0)	N/A	0.04 (1.0)
02	.52 (13.2)	.27 (6.9)	2.31 (58.7)	1.16 (29.5)	1.16 (29.5)	0.69 (17.5)	0.06 (1.5)
03	1.06 (26.9)	.53 (13.5)	4.73 (120.1)	2.36 (59.9)	2.37 (60.2)	1.40 (35.6)	0.09 (2.29)
04	2.19 (55.6)	1.19 (30.2)	9.70 (246.4)	4.85 (123.2)	4.85 (123.2)	2.79 (70.9)	0.12 (3.0)

*As Supplied **As Recovered



SERIES 77
AS85049 Boots



M85049/142 Wye Transition, Wide Body



AS85049 wide body 'WYE' heat shrink transitions provide mechanical and environmental protection from damage and debris. AS85049 straight boots are made in accordance with AS85049. All adhesive lined and unlined transitions are RoHS compliant. Transitions are water-tight when equipped with factory installed or user-installed adhesive. Choose transition size based on cable diameter.

B

How to Order					
Sample Part Number	M85049/142	-02	H	C	P
Product Series	M85049/142 = wide body wye transition AS85049 boot				
Dash No.	05, 06, 07, 08 ; See dimension table				
Material	A, B, G, H ; see material table				
Adhesive Option	C = adhesive lined, see adhesive table U = no adhesive				
Injection-Vent Ports	P = injection-vent port Omit for none				

Material			
Material	Compound	Material Description	Color Code
A	2071	Polyolefin Semi-Rigid	White
B	2040	Polyolefin Flexible	Red
G	2010	Polyolefin	Green
H	2025	Elastomeric	Blue

Adhesive		
Code	Material	Description
C	Material A, G, H	-55° to +125°C Hot Melt adhesive
	Material B	-55° to +70°C Zero Halogen/Hot Melt
For applications exposed to temperatures reaching 150°C contact the factory		

NOTES

1. See bag identification for matching boot number, no number on boot. See part number development for full description
2. Encircled material letter designator located on O.D. approximately mid length along the 'J' end see part number development for full description
3. Recovered dimension apply to unrestricted recovery. Dimensions may differ than shown when boots are installed over assembly.



SERIES 77
AS85049 Boots



M85049/142 Wye Transition, Wide Body

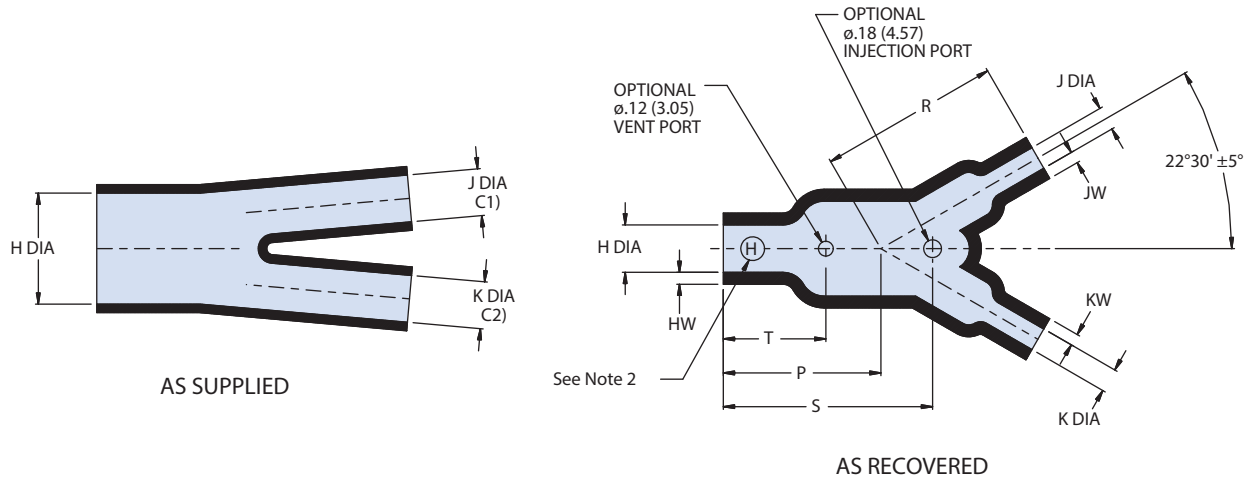

REF: AS85049/142
(FIG.2, Y TYPE BOOT)

B

Dimensions										
Dash No. 1	H Dia Min*	H Dia Max**	J & K Dia Min*	J & K Dia Max**	P** Ref	R** Ref	S** ±10%	T** ±10%	HW** ±20%	JW & KW** ±20%
05	0.52 (13.2)	0.24 (6.1)	0.26 (6.6)	0.13 (3.3)	0.88 (22.4)	0.76 (19.3)	0.94 (23.9)	0.61 (15.5)	0.06 (1.5)	0.04 (1.0)
06	1.06 (26.9)	0.49 (12.4)	0.52 (13.2)	0.24 (6.1)	1.50 (38.1)	1.70 (43.2)	2.10 (53.3)	1.30 (33.0)	0.10 (2.5)	0.06 (1.5)
07	1.52 (38.6)	0.71 (18.0)	1.06 (26.9)	0.49 (12.4)	2.58 (65.5)	3.10 (78.7)	3.10 (78.7)	2.20 (55.9)	0.12 (3.0)	0.10 (2.5)
08	2.19 (55.6)	1.02 (25.9)	1.06 (26.9)	0.50 (12.7)	3.35 (85.1)	3.70 (94.0)	4.40 (111.8)	2.80 (71.1)	0.18 (4.6)	0.10 (2.5)

*As Supplied **As Recovered



SERIES 77
AS85049 Boots



M85049/142 1 to 3 Type Heat Shrink Transition



AS85049 1 to 3 type heat shrink transitions provide mechanical and environmental protection from damage and debris. AS85049 straight boots are made in accordance with AS85049. All adhesive lined and unlined transitions are RoHS compliant. Transitions are water-tight when equipped with factory installed or user-installed adhesive. Choose transition size based on cable diameter.

B

How to Order					
Sample Part Number	M85049/142	-02	H	C	P
Product Series	M85049/142 = wide body wye transition AS85049 boot				
Dash No.	05, 06, 07, 08 ; See dimension table				
Material	A, B, G, H ; see material table				
Adhesive Option	C = adhesive lined, see adhesive table U = no adhesive				
Injection-Vent Ports	P = injection-vent port Omit for none				

Material			
Material	Compound	Material Description	Color Code
A	2071	Polyolefin Semi-Rigid	White
B	2040	Polyolefin Flexible	Red
G	2010	Polyolefin	Green
H	2025	Elastomeric	Blue

Adhesive		
Code	Material	Description
C	Material A, G, H	-55° to +125°C Hot Melt adhesive
	Material B	-55° to +70°C Zero Halogen/Hot Melt
For applications exposed to temperatures reaching 150°C contact the factory		

NOTES

1. See bag identification for matching boot number, no number on boot. See part number development for full description
2. Encircled material letter designator located on O.D. approximately mid length along the 'J' end see part number development for full description
3. Recovered dimension apply to unrestricted recovery. Dimensions may differ than shown when boots are installed over assembly.



SERIES 77
AS85049 Boots



M85049/142 1 to 3 Type Heat Shrink Transition

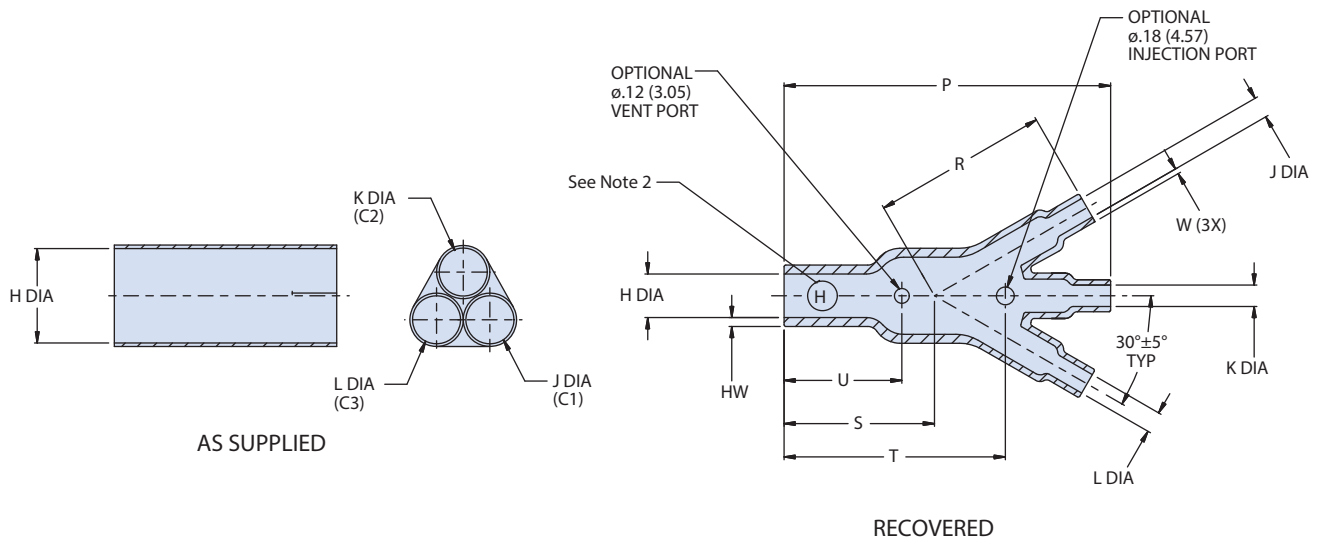

REF: AS85049/142
(FIG.3, 1 TO 3 TYPE BOOT)

Dimensions											
Dash No. See Note 1	H Dia Min*	H Dia Max**	J,K,L Dia Min*	J,K,L Dia Max**	P** ±10%	R** Ref	S** Ref	U** ±10%	T** ±10%	HW** ±20%	W** ±20%
09	0.52 (13.2)	0.26 (6.6)	0.26 (6.6)	0.14 (3.6)	1.82 (46.2)	1.00 (25.4)	0.82 (20.8)	0.62 (15.7)	1.20 (30.5)	0.06 (1.5)	0.04 (1.0)
10	1.06 (26.9)	0.53 (13.5)	0.52 (13.2)	0.27 (6.9)	3.67 (93.2)	1.98 (50.3)	1.69 (42.9)	1.30 (33.0)	2.25 (57.2)	0.10 (2.5)	0.06 (1.5)
11	1.52 (38.6)	0.75 (19.1)	0.76 (19.3)	0.38 (9.7)	5.32 (135.1)	2.90 (73.7)	2.42 (61.5)	1.80 (45.7)	3.50 (88.9)	0.12 (3.0)	0.07 (1.8)
12	2.19 (55.6)	1.00 (25.4)	1.06 (26.9)	0.49 (12.4)	7.56 (192.0)	4.06 (103.1)	3.50 (88.9)	2.80 (71.1)	4.80 (121.9)	0.18 (4.6)	0.12 (3.0)
13	3.60 (91.4)	2.15 (54.6)	1.80 (45.7)	1.08 (27.4)	15.37 (390.4)	8.31 (211.1)	7.06 (179.3)	5.00 (127.0)	10.0 (254.0)	0.28 (7.1)	0.18 (4.6)

*As Supplied **As Recovered

B

SERIES 77
SHRINK BOOTS

LIPPED BOOTS



Straight, 90°, 45° and 30° angle lipped boots available in standard, short, long tail, hi-ratio, heavy wall and convoluted styles.



Straight, 90°, 45° and 30° angle boots with lip for attachment to standard circular connector adapters and connectors with integral boot groove. After shrinking, the boot lip locks into boot groove to keep out environmental debris. Order with optional adhesive coating for a watertight, high-strength bond to the cable jacket and adapter. Eyelet holes are available for popular styles to provide a convenient attachment point for dust caps or protective covers. Choose from 8 material options to suit operating temperatures and conditions. Also available in halogen free material for regulated environmental safety applications. Choose boot size based on adapter diameter and cable diameter.

Glenair®

Glenair, Inc.
1211 Air Way
Glendale, CA 91201-2497
818-247-6000
sales@glenair.com
www.glenair.com



SERIES 77
Lipped Shrink Boots
 Product Selection Guide



Lipped Boot Selection and Reference Guide C-2



Straight Boots

- Standard C-4
- Short C-8
- Long Tail C-12
- Hi-Ratio C-16
- Heavy Wall C-18
- Convolute C-22



90° Angle Boots

- Standard C-24
- Long Tail C-22
- Hi-Ratio C-22



45° Angle Boots

- Standard C-36



SERIES 77

Lipped Shrink Boots



Shrink Boot Selection and Reference Guide

Lipped Straight, 90° and 45° Angle Shrink Boots



- Easy attachment to shrink boot adapters
- Eight material options
- Four adhesive options
- With or without eyelets
- With or without potting ports or drain holes
- Non-adhesive lined boots (For use with Type U two-part epoxy):



Part Number
779-001



Part Number
779-002

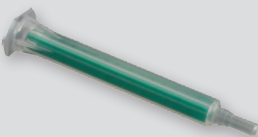

Part Number	Package Size
779-003	12

See Section G for complete installation guide

Lipped shrink boots can be attached to connectors with integral boot grooves or onto shrink boot adapters. Once recovered boots lock into boot groove to provide a robust water-tight fit. Boots are available with or without eyelet hole, allowing for convenient attachment of protective covers and can be ordered in straight, 90°, 45° and 30° angle configurations. Shrink boots provide environmental and mechanical protection as well as wire strain relief.

Recommended Material Selection

Type 1 high performance, semi-rigid elastomer for extreme temperatures and excellent resistance to fuels and oils and rated for 3000 hours continuous operation at +150°C. Material meets requirements of VG95343 Type 6, BSG 198-5-DE, EN62329-102 and SAE AS5258 Type H. Temperature rating -75°C to 150°C

Type 2 semi-flexible low smoke zero halogen (LSZH) flame-retarded polyolefin meets low smoke and toxicity requirements of shipboard, transit and aircraft systems and rated for 3000 hours continuous operation at +130° C. Temperature rating -40° C to +130°C. Material meets the requirements of SAE AS5258 Type G.

Type 3 self extinguishing, flexible polyolefin boots meet SAE AS81765 Type II requirements and offers good resistance to oils and fuels. Good all around general duty shrink boot solution. Temperature rating of -55° C to +135°C. Material Meets the Requirements of SAE AS5258 Type B.

Type 5 flexible Viton® Fluoroelastomer boot for extreme temperatures where excellent resistance to fuels, fluids, solvents is needed. Temperature rating of -55° C to +150°C. Material meets the requirements of SC-X15111D.

Type 6 high performance, flexible elastomer alloy are well suited for high temperatures within areas prone to oil and fluid exposure. Temperature rating of -55° to +135°C. Material meets the requirements of SC-X15112C.

Type 7 highly flexible polyolefin boots are well suited for high temperatures within areas prone to oil and fluid exposure. Temperature rating of -55° to +135°C. Material meets the requirements of SAE AS5258 Type A.

Type 8 semi-rigid, low outgassing fluoropolymer alloy meets NASA low out-gassing test requirements and are suitable for high altitude and space applications. Excellent resistance to oils, fuels, solvents, acids and bases. Broad operating temperature of -50° C to +175° C provides excellent high temperature stability and low temperature flexibility for extreme temperatures. The recommended Adhesive is 779-001 two-part epoxy.

Type 9 low temp application, flexible polyolefin for Ethernet and USB cables susceptible to heat damage from the application of boots with higher minimum shrink temperatures. Resistance to oils, fuels, solvents, acids and bases is fair. Temperature rating of -40° to +100°C.



SERIES 77

Lipped Shrink Boots

Shrink Boot Selection and Reference Guide

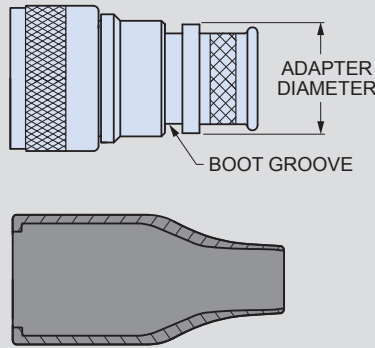

Boot Size	Adapter Diameter		Min. Cable Diameter	Boot Size	Adapter Diameter		Min. Cable Diameter
	Min	Max	In.		Min	Max	In.
00S	.250 (6.35)	.325 (8.26)	.110 (2.79)	06	.900 (22.86)	1.350 (34.29)	.375 (9.53)
00	.250 (6.35)	.325 (8.26)	.110 (2.79)	07	1.250 (31.75)	1.650 (41.91)	.425 (10.80)
01	.325 (7.62)	.425 (10.80)	.150 (3.81)	08	1.400 (35.56)	2.250 (57.15)	.625 (15.88)
02	.350 (8.89)	.600 (15.24)	.175 (4.45)	09	1.870 (47.50)	2.470 (62.70)	.700 (17.78)
03	.450 (11.43)	.850 (21.59)	.225 (5.72)	10	2.38 (60.45)	3.25 (82.55)	1.10 (27.94)
04	.600 (15.24)	1.000 (25.40)	.275 (6.99)	11	.325 (8.25)	.425 (10.80)	.120 (3.05)
05	.750 (19.05)	1.200 (30.48)	.300 (7.62)	12	.425 (10.80)	.600 (15.24)	.220 (5.59)

Material Type	Flexibility	Continuous Operating Temp.	Resistance to Fuels, Oils	Flammability	Low Temperature Flexibility	Low Toxicity, Zero Halogen
Type 1 High-Performance Semi-Rigid Elastomer	Semi-rigid	-75° C to +150° C	Excellent	Self-Extinguishing <15 Sec	-75° C	No
Type 2 Zero Halogen Semi-Rigid Polyolefin	Semi-flexible	-40° C to +130° C	Very Good	Self-Extinguishing <15 Sec	-40° C	Yes
Type 3 General Purpose Flexible Polyolefin	Flexible	-55° C to +135° C	Good	Self-Extinguishing <120 Sec	-55° C	No
Type 5 Viton Fluoroelastomer Blend	Flexible	-55° C to +150° C	Excellent	Self-Extinguishing <60 Sec	-65° C	No
Type 6 High Performance Elastomer Alloy	Flexible	-55° C to +135° C	Excellent	Self-Extinguishing <60 Sec	-65° C	No
Type 7 Semi-Rigid Polyolefin	Highly Flexible	-55° C to +135° C	Good	Self-Extinguishing <60 Sec	-55° C	No
Type 8 Low Outgassing Fluoropolymer Alloy	Semi-Rigid	-50° C to +175° C	Excellent	Self-Extinguishing <60 Sec	-50° C	No
Type 9 Low Temp Flexible Polyolefin	Flexible	-40° C to +100° C	Fair	Self-Extinguishing <120 Sec	-40° C	No

Attribute	W1 High Performance Adhesive	W2 Low Temp Adhesive	W3 TACOM Approved Adhesive	R High Performance Epoxy Adhesive	779-001 Two Part Epoxy Adhesive
Boot Material Compatibility	Types 1, 2, 5, 6 and 7	Types 1, 2, 3, 7 and 9	Types 5 and 6	Type 1, 2 and 5	All Material Types
Continuous Operating Temp.	-55° to +125°C	-55° to +70°C	-55° to +125°C	-75° to +150°C	-75° to +150°C
Resistance to Fuels, Oils, and Fluids	Good	Good	Good	Excellent	Excellent
Low Toxicity, Zero Halogen	Yes	Yes	No	Yes	Yes



SERIES 77

Lipped, Straight Shrink Boots



770-001S Straight Boot, with Eyelet
How to Order

Straight Boots



Lipped, straight shrink boots provide mechanical and environmental protection from damage and debris. Standard boots are available in eight material options with five adhesive choices. Glenair straight boots are made in accordance with AS85045 and fit most standard boot adapters for circular connectors. All adhesive lined and unlined shrink boots are RoHS compliant. Shrink boots are water-tight when equipped with factory installed or user-installed adhesive. Lipped boots lock into boot groove located on adapter and can be ordered with potting holes to fit your requirements. These lipped boots come standard with eyelet for attachment of protective covers. Choose boot size based on adapter diameter and cable diameter.

How to Order

Sample Part Number	770	-001	S	1	03	W1	-PP
Product Series	770 = Series 77 shrink boot						
Basic Number	001 = lipped boot with eyelet						
Angular Function	S = straight						
Material	See material and adhesives table						
Boot Size	03, 04, 05, 06, 07, 08, 09; see dimensions table						
Adhesive Lined	Omit for none; see material and adhesives table						
Potting Ports	PP = potting port Omit for none						

Material and Adhesive Compatibility

Material Code	Material Description (Compound No.)	Hot Melt Adhesives			High Performance Epoxy Adhesives		
		W1	W2	W3 (TACOM approved)	R	U	
		High Temperature -55°C to 125°C	Standard -55°C to 70°C	Elastomeric -55°C to 125°C	Pre-Coat -75°C to 150°C	Two-Part -75°C to 155°C	
1	High-Performance Semi-Rigid Elastomer (2025)	●	●		●	Type U epoxy adhesive is compatible with all boot materials. Ordered separately, user-installed (779-001). Order boot with no adhesive lining.	
2	Zero Halogen Semi-Rigid Polyolefin (2010)	●	●		●		
3	General Purpose Flexible Polyolefin (2040)		●				
5	Viton Fluoroelastomer Blend (2050)	●		●	●		
6	High Performance Elastomer Alloy (2051)	●		●			
7	Semi-Rigid Polyolefin (2071)	●	●				
8	Low Outgassing Fluoropolymer Alloy (2008)	Material Type 8 not available with pre-coat adhesive. Use Type U two-part epoxy					
9	Low Temp Flexible Polyolefin (2013)		●				

NOTES

1. See **Modification Codes** listed in Section A for material color options available for **Type 1 (compound 2025)** material.
2. Recovered dimension apply to unrestricted recovery. Dimensions may differ than shown when boots are installed over assembly.



SERIES 77

Lipped, Straight Shrink Boots



770-001S Straight Boot, with Eyelet Dimensions

Lipped Straight Adapter Shrink Boots, Standard: Dimensions

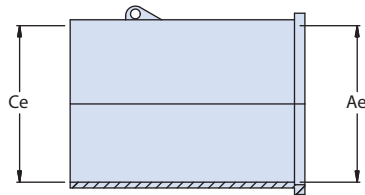

AS SUPPLIED

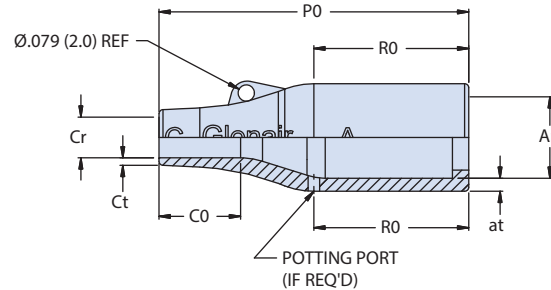

RECOVERED (-001)

Dimensions Table											
Boot Size	Glenair US Part Marking	Shell Size	Ae Dia Min	Ce Dia Min	Ar Dia Max	at ±30%	Cr Dia Max	ct ±20%	CO Ref	PO ±10%	RO Ref
03	S03	8,10	.945 (24.0)	.945 (24.0)	.413 (10.5)	.063 (1.6)	.197 (5.0)	.035 (0.9)	.394 (10.0)	1.496 (38.0)	.748 (19.0)
04	S04	11-16	1.181 (30.0)	1.181 (30.0)	.551 (14.0)	.071 (1.8)	.236 (6.0)	.039 (1.0)	.630 (16.0)	2.165 (55.0)	1.181 (30.0)
05	S05	16-17	1.260 (32.0)	1.260 (32.0)	.709 (18.0)	.071 (1.8)	.276 (7.0)	.047 (1.2)	.748 (19.0)	2.638 (67.0)	1.299 (33.0)
06	S06	17-21	1.417 (36.0)	1.417 (36.0)	.866 (22.0)	.079 (2.0)	.335 (8.5)	.047 (1.2)	.787 (20.0)	3.150 (80.0)	1.575 (40.0)
07	S07	21-23	1.693 (43.0)	1.693 (43.0)	1.102 (28.0)	.087 (2.2)	.394 (10.0)	.051 (1.3)	1.142 (29.0)	3.898 (99.0)	2.165 (55.0)
08	S08	25	2.362 (60.0)	2.362 (60.0)	1.378 (35.0)	.130 (3.3)	.591 (15.0)	.063 (1.6)	1.575 (40.0)	5.118 (130.0)	1.969 (50.0)
09	S09		2.599 (66.0)	2.599 (66.0)	1.752 (44.5)	.150 (3.8)	.661 (16.8)	.079 (2.0)	2.283 (58.0)	6.693 (170.0)	3.543 (90.0)

For materials Type 2, Type 3 and Type 9, dimension 'Ce' is nominal

Lipped Straight Shrink Boots: Part Marking, Raised Lettering

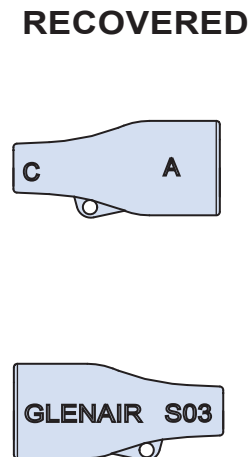
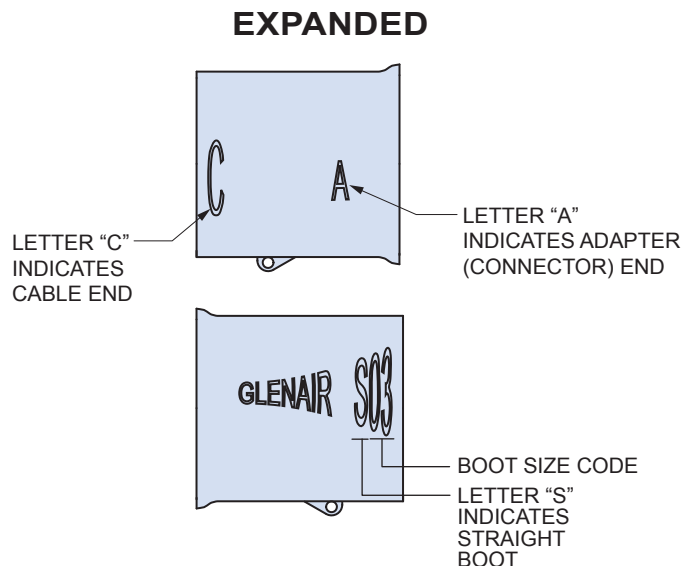



SERIES 77

Lipped, Straight Shrink Boots



770-003S Straight Boot, without Eyelet
How to Order

Straight Boots



Lipped, straight shrink boots provide mechanical and environmental protection from damage and debris. Standard boots are available in eight material options with five adhesive choices. Glenair straight boots fit most standard boot adapters for circular connectors. All adhesive lined and unlined shrink boots are RoHS compliant. Shrink boots are water-tight when equipped with factory installed or user-installed adhesive. Lipped boots lock into boot groove located on adapter and can be ordered with potting holes or drain holes according to your requirements. Choose boot size based on adapter diameter and cable diameter.

C

How to Order							
Sample Part Number	770	-003	S	1	03	W1	-PP
Product Series	770 = Series 77 shrink boot						
Basic Number	003 = lipped boot						
Angular Function	S = straight						
Material	See material and adhesives table						
Boot Size	00S, 00, 01, 02, 03, 04, 05, 06, 07, 08, 09, 10, 11, 12; see shell size cross reference in dimensions table						
Adhesive Lined	Omit for no adhesive; see material and adhesives table						
Potting Ports or Drain Holes	PP = potting port DH = drain hole Omit for none						

Material and Adhesive Compatibility						
Material Code	Material Description (Compound No.)	Hot Melt Adhesives			High Performance Epoxy Adhesives	
		W1	W2	W3 (TACOM approved)	R	U
		High Temperature -55°C to 125°C	Standard -55°C to 70°C	Elastomeric -55°C to 125°C	Pre-Coat -75°C to 150°C	Two-Part -75°C to 155°C
1	High-Performance Semi-Rigid Elastomer (2025)	●	●		●	Type U epoxy adhesive is compatible with all boot materials. Ordered separately, user-installed (779-001). Order boot with no adhesive lining.
2	Zero Halogen Semi-Rigid Polyolefin (2010)	●	●		●	
3	General Purpose Flexible Polyolefin (2040)		●			
5	Viton Fluoroelastomer Blend (2050)	●		●	●	
6	High Performance Elastomer Alloy (2051)	●		●		
7	Semi-Rigid Polyolefin (2071)	●	●			
8	Low Outgassing Fluoropolymer Alloy (2008)	Material Type 8 not available with pre-coat adhesive. Use Type U two-part epoxy				
9	Low Temp Flexible Polyolefin (2013)		●			

NOTES

1. See **Modification Codes** listed in Section A for material color options available for **Type 1 (compound 2025)** material.
2. Recovered dimension apply to unrestricted recovery. Dimensions may differ than shown when boots are installed over assembly.



SERIES 77

Lipped, Straight Shrink Boots



770-003S Straight Boot, without Eyelet Dimensions

Lipped Straight Adapter Shrink Boots, Standard: Dimensions

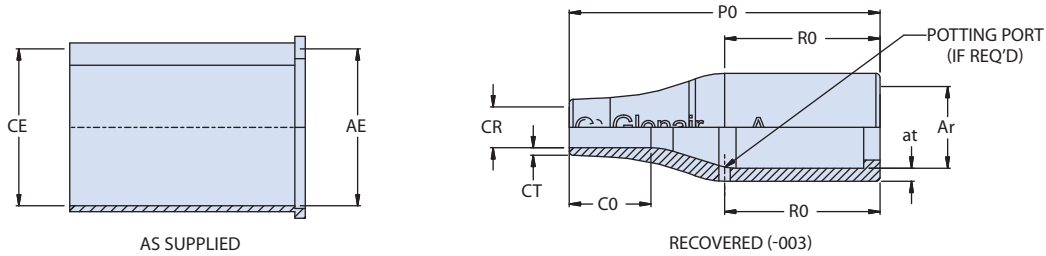

770-003 Dimensions Table												
Boot Size	Glenair Us Part Marking	AS85049 /140 Ref	Shell Size	Ae DIA MIN	Ce DIA MIN	Ar DIA MAX	at ±30%	Cr DIA MAX	ct ±20%	CO REF	PO ±10%	RO REF
00S	00S		5	.354 (9.0)	.354 (9.0)	.217 (5.5)	.039 (1.0)	.079 (2.0)	.028 (0.7)	.295 (7.5)	.630 Max (16)	.385 (9.8)
00	S00		5	.354 (9.0)	.354 (9.0)	.217 (5.5)	.039 (1.0)	.079 (2.0)	.028 (0.7)	.295 (7.5)	.984 (25.0)	.551 (14.0)
01	S01		5,6	.472 (12.0)	.472 (12.0)	.276 (7.0)	.043 (1.1)	.118 (3.0)	.028 (0.7)	.295 (7.5)	.984 (25.0)	.551 (14.0)
02	S02		6,7	.669 (17.0)	.669 (17.0)	.276 (7.0)	.051 (1.3)	.138 (3.5)	.028 (0.7)	.394 (10.0)	1.181 (30.0)	.728 (18.5)
03	S03	01	8,10	.945 (24.0)	.945 (24.0)	.413 (10.5)	.063 (1.6)	.197 (5.0)	.035 (0.9)	.394 (10.0)	1.496 (38.0)	.748 (19.0)
04	S04	02	11-16	1.181 (30.0)	1.181 (30.0)	.551 (14.0)	.071 (1.8)	.236 (6.0)	.039 (1.0)	.630 (16.0)	2.165 (55.0)	1.181 (30.0)
05	S05	03	16-17	1.260 (32.0)	1.260 (32.0)	.709 (18.0)	.071 (1.8)	.276 (7.0)	.047 (1.2)	.748 (19.0)	2.638 (67.0)	1.299 (33.0)
06	S06	04	17-21	1.417 (36.0)	1.417 (36.0)	.866 (22.0)	.079 (2.0)	.335 (8.5)	.047 (1.2)	.787 (20.0)	3.150 (80.0)	1.575 (40.0)
07	S07	05	21-23	1.693 (43.0)	1.693 (43.0)	1.102 (28.0)	.087 (2.2)	.394 (10.0)	.051 (1.3)	1.142 (29.0)	3.898 (99.0)	2.165 (55.0)
08	S08	06	25	2.362 (60.0)	2.362 (60.0)	1.378 (35.0)	.130 (3.3)	.591 (15.0)	.063 (1.6)	1.575 (40.0)	5.118 (130.0)	1.969 (50.0)
09	S09	07		2.599 (66.0)	2.599 (66.0)	1.752 (44.5)	.150 (3.8)	.661 (16.8)	.079 (2.0)	2.283 (58.0)	6.693 (170.0)	3.543 (90.0)
10	S10	08		3.400 (86.4)	3.400 (86.4)	2.250 (57.2)	.160 (4.1)	1.06 (26.9)	.130 (3.3)	2.068 (52.5)	7.700 (195.6)	4.005 (102.0)
11	S11		5,6	.472 (12.0)	.472 (12.0)	.276 (7.0)	.043 (1.1)	.093 (2.4)	.028 (0.7)	.354 (9.0)	1.417 (36.0)	.750 (19.1)
12	S12		6,7	.669 (17.0)	.669 (17.0)	.375 (9.5)	.051 (1.3)	.187 (4.7)	.028 (0.7)	.394 (10.0)	1.496 (38.0)	.750 (19.1)

For materials Type 2, Type 3 and Type 9, dimension 'Ce' is nominal

Lipped Straight Shrink Boots: Part Marking, Raised Lettering

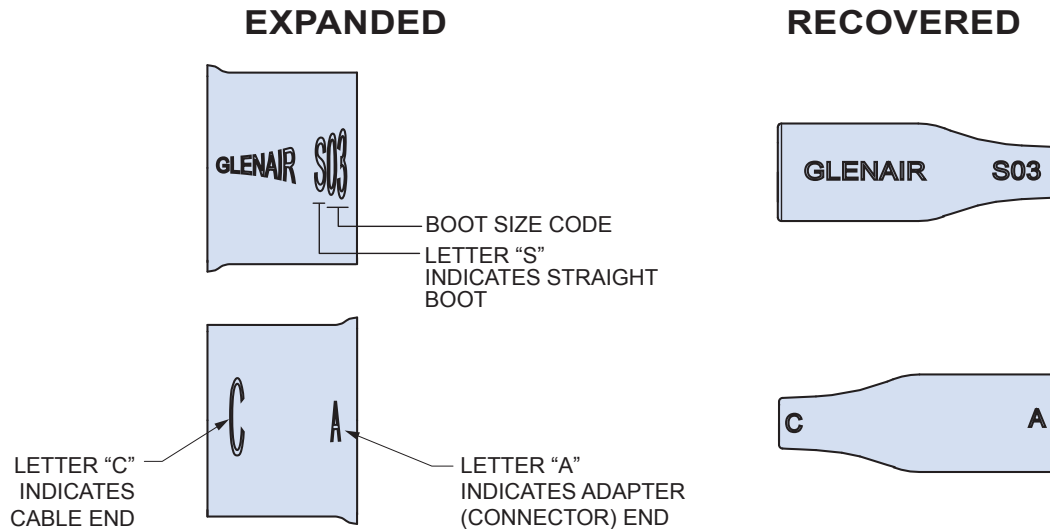



SERIES 77

Lipped, Straight Shrink Boots



770-002S Short Boot, with Eyelet
How to Order

Straight Boots



Lipped, straight shrink boots provide mechanical and environmental protection from damage and debris. Short straight boots are available in eight material options with five adhesive choices. Glenair straight boots fit most standard boot adapters for circular connectors. All adhesive lined and unlined shrink boots are RoHS compliant. Shrink boots are water-tight when equipped with factory installed or user-installed adhesive. Lipped boots lock into boot groove located on adapter and can be ordered with potting holes or drain holes according to your requirements. Choose boot size based on adapter diameter and cable diameter. Short profile boots ideal for reduced package size applications.

C

How to Order							
Sample Part Number	770	-002	S	1	03	W1	-PP
Product Series	770 = Series 77 shrink boot						
Basic Number	002 = short lipped boot with eyelet						
Angular Function	S = straight						
Material	See material and adhesives table						
Boot Size	03, 04, 05, 06, 07, 08, 09 ; see dimensions table						
Adhesive Lined	Omit for none; see material and adhesives table						
Potting Ports or Drain Holes	PP = potting port Omit for none						

Material and Adhesive Compatibility						
Material Code	Material Description (Compound No.)	Hot Melt Adhesives			High Performance Epoxy Adhesives	
		W1	W2	W3 (TACOM approved)	R	U
		High Temperature -55°C to 125°C	Standard -55°C to 70°C	Elastomeric -55°C to 125°C	Pre-Coat -75°C to 150°C	Two-Part -75°C to 155°C
1	High-Performance Semi-Rigid Elastomer (2025)	●	●		●	Type U epoxy adhesive is compatible with all boot materials. Ordered separately, user-installed (779-001). Order boot with no adhesive lining.
2	Zero Halogen Semi-Rigid Polyolefin (2010)	●	●		●	
3	General Purpose Flexible Polyolefin (2040)		●			
5	Viton Fluoroelastomer Blend (2050)	●		●	●	
6	High Performance Elastomer Alloy (2051)	●		●		
7	Semi-Rigid Polyolefin (2071)	●	●			
8	Low Outgassing Fluoropolymer Alloy (2008)	Material Type 8 not available with pre-coat adhesive. Use Type U two-part epoxy				
9	Low Temp Flexible Polyolefin (2013)		●			

NOTES

1. See **Modification Codes** listed in Section A for material color options available for **Type 1 (compound 2025)** material.
2. Recovered dimension apply to unrestricted recovery. Dimensions may differ than shown when boots are installed over assembly.



SERIES 77

Lipped, Straight Shrink Boots



770-002S Short Boot, with Eyelet
Dimensions

Lipped Straight Adapter Shrink Boots, Short: Dimensions

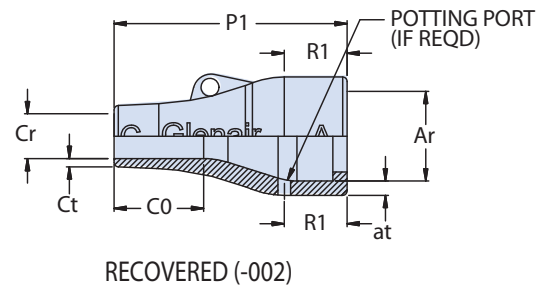
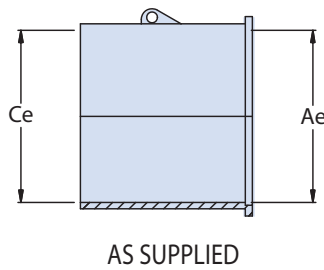

Dimensions Table											
Boot Size	Glenair US Part Marking	Shell Size	Ae Dia Min	Ce Dia Min	Ar Dia Max	at ±30%	Cr Dia Max	ct ±20%	CO Ref	P1 ±10%	R1 Ref
03	S03	8,10	.945 (24.0)	.945 (24.0)	.413 (10.5)	.063 (1.6)	.197 (5.0)	.035 (0.9)	.394 (10.0)	1.024 (26.0)	.276 (7.0)
04	S04	11-16	1.181 (30.0)	1.181 (30.0)	.551 (14.0)	.071 (1.8)	.236 (6.0)	.039 (1.0)	.630 (16.0)	1.693 (43.0)	.709 (18.0)
05	S05	16-17	1.260 (32.0)	1.260 (32.0)	.709 (18.0)	.071 (1.8)	.276 (7.0)	.047 (1.2)	.748 (19.0)	1.850 (47.0)	.512 (13.0)
06	S06	17-21	1.417 (36.0)	1.417 (36.0)	.866 (22.0)	.079 (2.0)	.335 (8.5)	.047 (1.2)	.787 (20.0)	2.362 (60.0)	.787 (20.0)
07	S07	21-23	1.693 (43.0)	1.693 (43.0)	1.102 (28.0)	.087 (2.2)	.394 (10.0)	.051 (1.3)	1.142 (29.0)	3.150 (80.0)	1.417 (36.0)
08	S08	25	2.362 (60.0)	2.362 (60.0)	1.378 (35.0)	.130 (3.3)	.591 (15.0)	.063 (1.6)	1.575 (40.0)	4.331 (110.0)	1.181 (30.0)
09	S09		2.599 (66.0)	2.599 (66.0)	1.752 (44.5)	.150 (3.8)	.661 (16.8)	.079 (2.0)	2.283 (58.0)	5.910 (150.0)	2.760 (70.0)

For materials Type 2, Type 3 and Type 9, dimension 'Ce' is nominal

Lipped Straight Shrink Boots: Part Marking, Raised Lettering

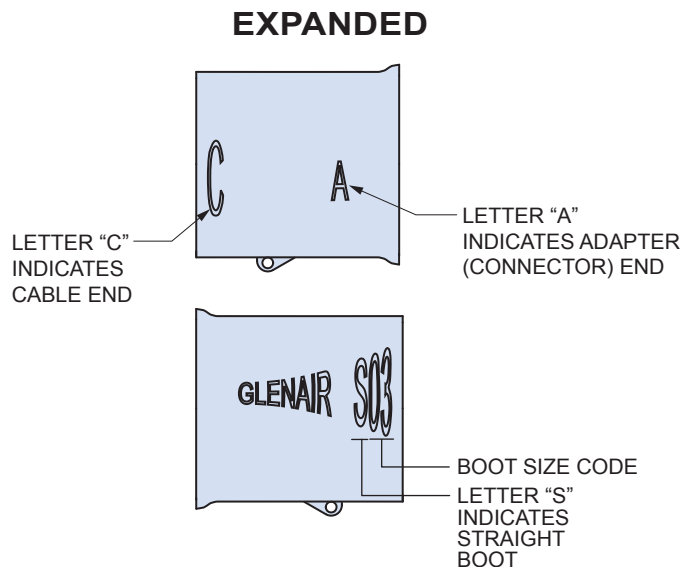



SERIES 77

Lipped, Straight Shrink Boots



770-004S Short Straight Boot, without Eyelet How to Order

Straight Boots



Lipped, straight shrink boots provide mechanical and environmental protection from damage and debris. Short straight boots are available in eight material options with five adhesive choices. Glenair straight boots fit most standard boot adapters for circular connectors. All adhesive lined and unlined shrink boots are RoHS compliant. Shrink boots are water-tight when equipped with factory installed or user-installed adhesive. Lipped boots lock into boot groove located on adapter and can be ordered with potting holes or drain holes according to your requirements. Choose boot size based on adapter diameter and cable diameter. Short profile boots ideal for reduced package size applications.

C

How to Order							
Sample Part Number	770	-004	S	1	03	W1	-PP
Product Series	770 = Series 77 shrink boot						
Basic Number	004 = short lipped boot						
Angular Function	S = straight						
Material	See material and adhesives table						
Boot Size	03, 04, 05, 06, 07, 08, 09; see shell size in dimensions table						
Adhesive Lined	Omit for no adhesive; see material and adhesives table						
Potting Ports or Drain Holes	PP = potting port DH = drain hole Omit for none						

Material and Adhesive Compatibility						
Material Code	Material Description (Compound No.)	Hot Melt Adhesives			High Performance Epoxy Adhesives	
		W1	W2	W3 (TACOM approved)	R	U
		High Temperature -55°C to 125°C	Standard -55°C to 70°C	Elastomeric -55°C to 125°C	Pre-Coat -75°C to 150°C	Two-Part -75°C to 155°C
1	High-Performance Semi-Rigid Elastomer (2025)	●	●		●	Type U epoxy adhesive is compatible with all boot materials. Ordered separately, user-installed (779-001). Order boot with no adhesive lining.
2	Zero Halogen Semi-Rigid Polyolefin (2010)	●	●		●	
3	General Purpose Flexible Polyolefin (2040)		●			
5	Viton Fluoroelastomer Blend (2050)	●		●	●	
6	High Performance Elastomer Alloy (2051)	●		●		
7	Semi-Rigid Polyolefin (2071)	●	●			
8	Low Outgassing Fluoropolymer Alloy (2008)	Material Type 8 not available with pre-coat adhesive. Use Type U two-part epoxy				
9	Low Temp Flexible Polyolefin (2013)		●			

NOTES

1. See **Modification Codes** listed in Section A for material color options available for **Type 1 (compound 2025)** material.
2. Recovered dimension apply to unrestricted recovery. Dimensions may differ than shown when boots are installed over assembly.



SERIES 77

Lipped, Straight Shrink Boots



770-004S Short Straight Boot, without Eyelet Dimensions

Lipped Straight Adapter Shrink Boots, Short: Dimensions

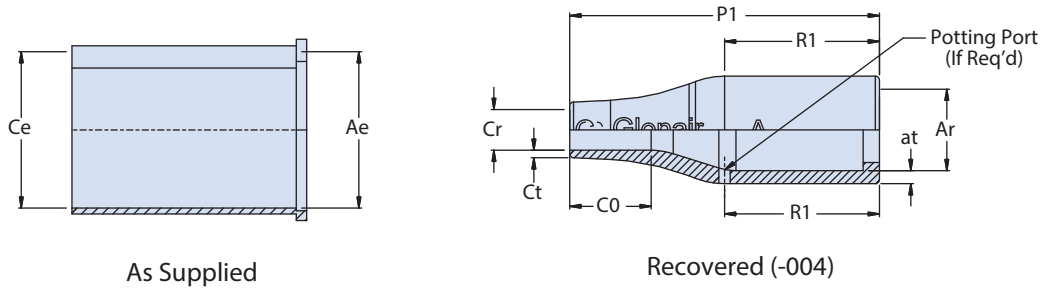

As Supplied

Recovered (-004)

Dimensions Table

Boot Size	Glenair Us Part Marking	Shell Size	Ae DIA MIN	Ce DIA MIN	Ar DIA MAX	at ±30%	Cr DIA MAX	ct ±20%	CO REF	P1 ±10%	R1 REF
03	S03	8,10	.945 (24.0)	.945 (24.0)	.413 (10.5)	.063 (1.6)	.197 (5.0)	.035 (0.9)	.394 (10.0)	1.024 (26.0)	.276 (7.0)
04	S04	11-16	1.181 (30.0)	1.181 (30.0)	.551 (14.0)	.071 (1.8)	.236 (6.0)	.039 (1.0)	.630 (16.0)	1.693 (43.0)	.709 (18.0)
05	S05	16-17	1.260 (32.0)	1.260 (32.0)	.709 (18.0)	.071 (1.8)	.276 (7.0)	.047 (1.2)	.748 (19.0)	1.850 (47.0)	.512 (13.0)
06	S06	17-21	1.417 (36.0)	1.417 (36.0)	.866 (22.0)	.079 (2.0)	.335 (8.5)	.047 (1.2)	.787 (20.0)	2.362 (60.0)	.787 (20.0)
07	S07	21-23	1.693 (43.0)	1.693 (43.0)	1.102 (28.0)	.087 (2.2)	.394 (10.0)	.051 (1.3)	1.142 (29.0)	3.150 (80.0)	1.417 (36.0)
08	S08	25	2.362 (60.0)	2.362 (60.0)	1.378 (35.0)	.130 (3.3)	.591 (15.0)	.063 (1.6)	1.575 (40.0)	4.331 (110.0)	1.181 (30.0)
09	S09		2.599 (66.0)	2.599 (66.0)	1.752 (44.5)	.150 (3.8)	.661 (16.8)	.079 (2.0)	2.283 (58.0)	5.910 (150.0)	2.760 (70.0)

For materials Type 2, Type 3 and Type 9, dimension 'Ce' is nominal

Lipped Straight Shrink Boots: Part Marking, Raised Lettering

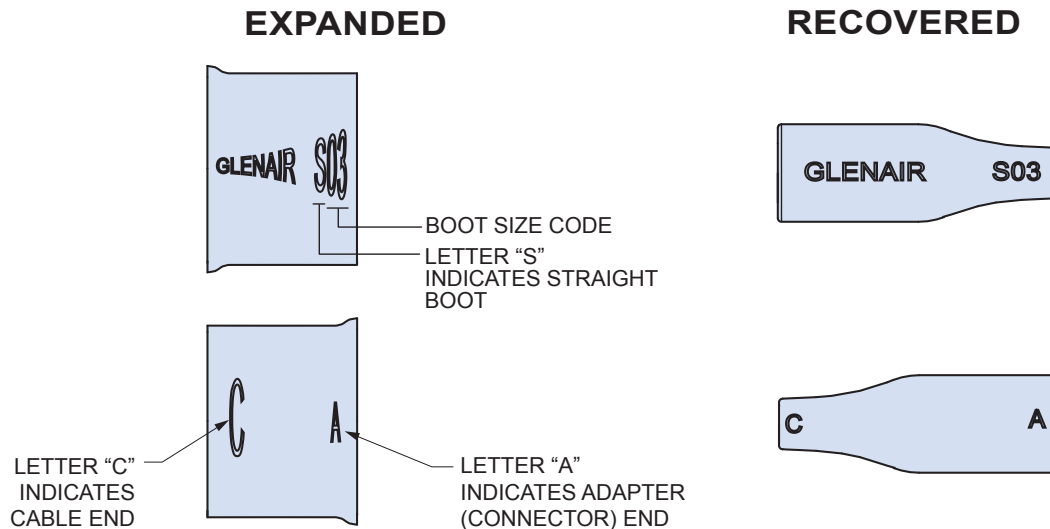



SERIES 77

Lipped, Straight Shrink Boots



770-006S Long Tail Boot
How to Order

Straight Boots



Lipped, long tail straight shrink boots provide mechanical and environmental protection from damage and debris. Long tail boots provide additional strain relief compared to standard length boots and are available in eight material options with five adhesive choices. Glenair straight boots fit most standard boot adapters for circular connectors. All adhesive lined and unlined shrink boots are RoHS compliant. Shrink boots are water-tight when equipped with factory installed or user-installed adhesive. Lipped boots lock into boot groove located on adapter and can be ordered with potting holes or drain holes according to your requirements. Choose boot size based on adapter diameter and cable diameter.

How to Order

Sample Part Number	770	-006	S	1	03	W1	-PP
Product Series	770 = Series 77 shrink boot						
Basic Number	006 = lipped boot, long tail						
Angular Function	S = straight						
Material	See material and adhesives table						
Boot Size	01, 02, 03, 04, 05, 05-22, 06, 06-22, 07, 08, 09, 10, 11; see dimensions table						
Adhesive Lined	Omit for no adhesive; see material and adhesives table						
Potting Ports or Drain Holes	PP = potting port DH = drain hole Omit for none						

Material and Adhesive Compatibility

Material Code	Material Description (Compound No.)	Hot Melt Adhesives			High Performance Epoxy Adhesives		
		W1	W2	W3 (TACOM approved)	R	U	
		High Temperature -55°C to 125°C	Standard -55°C to 70°C	Elastomeric -55°C to 125°C	Pre-Coat -75°C to 150°C	Two-Part -75°C to 155°C	
1	High-Performance Semi-Rigid Elastomer (2025)	●	●		●	Type U epoxy adhesive is compatible with all boot materials. Ordered separately, user-installed (779-001). Order boot with no adhesive lining.	
2	Zero Halogen Semi-Rigid Polyolefin (2010)	●	●		●		
3	General Purpose Flexible Polyolefin (2040)		●				
5	Viton Fluoroelastomer Blend (2050)	●		●	●		
6	High Performance Elastomer Alloy (2051)	●		●			
7	Semi-Rigid Polyolefin (2071)	●	●				
8	Low Outgassing Fluoropolymer Alloy (2008)	Material Type 8 not available with pre-coat adhesive. Use Type U two-part epoxy					
9	Low Temp Flexible Polyolefin (2013)		●				

NOTES

- See **Modification Codes** listed in Section A for material color options available for **Type 1 (compound 2025)** material.
- Recovered dimension apply to unrestricted recovery. Dimensions may differ than shown when boots are installed over assembly.

Part Number Cross Reference

Boot Size	Glenair Part Marking	AS85049/140 AS85049/141	Boot Size	Glenair Part Marking	AS85049/140 AS85049/141
01	S01		06-22	S06	
02	S02	09	07	S07	14
03	S03	10	08	S08	15
04	S04	11	09	S09	16
05	S05	12	10	S10	17
05-22	S05		11	S11	18
06	S06	13			



SERIES 77

Lipped, Straight Shrink Boots



770-006S Long Tail Boot
Dimensions

Lipped Straight Adapter Shrink Boots, Standard: Dimensions

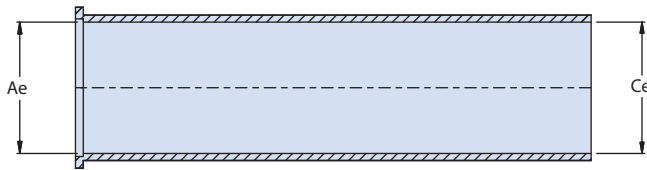

STRAIGHT - AS SUPPLIED

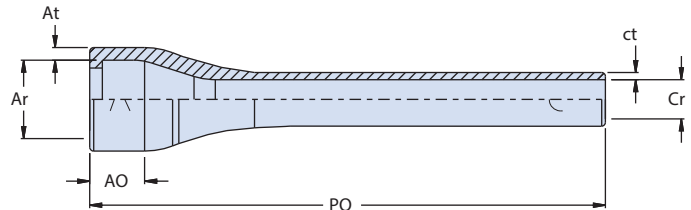

STRAIGHT - RECOVERED

Straight Boots

Dimensions

Boot Size	Glenair Part Marking	Ae Dia Min	Ce Dia Min	Ar Dia Max	at $\pm 30\%$	AO Ref	Cr Dia Max	ct $\pm 20\%$	PO $\pm 10\%$
01	S01	.620 (15.7)	.620 (15.7)	.290 (7.4)	.054 (1.37)	.500 (12.7)	.125 (3.17)	.043 (1.1)	4.000 (101.6)
02	S02	.886 (22.5)	.886 (22.5)	.433 (11.0)	.059 (1.5)	.551 (14.0)	.256 (6.5)	.047 (1.2)	4.330 (110.0)
03	S03	.984 (25.0)	.984 (25.0)	.591 (15.0)	.059 (1.5)	.591 (15.0)	.295 (7.5)	.047 (1.2)	4.724 (120.0)
04	S04	1.181 (30.0)	1.181 (30.0)	.748 (19.0)	.071 (1.8)	.591 (15.0)	.335 (8.5)	.047 (1.2)	5.512 (140.0)
05	S05	1.378 (35.0)	1.378 (35.0)	.827 (21.0)	.071 (1.8)	.787 (20.0)	.374 (9.5)	.047 (1.2)	6.299 (160.0)
05-22	S05	1.378 (35.0)	1.378 (35.0)	.827 (21.0)	.071 (1.8)	.787 (20.0)	.374 (9.5)	.047 (1.2)	4.000 (101.6)
06	S06	1.476 (37.5)	1.476 (37.5)	1.181 (30.0)	.079 (2.0)	.787 (20.0)	.413 (10.5)	.047 (1.2)	7.087 (180.0)
06-22	S06	1.476 (37.5)	1.476 (37.5)	1.181 (30.0)	.079 (2.0)	.787 (20.0)	.413 (10.5)	.047 (1.2)	4.250 (108.0)
07	S07	1.772 (45.0)	1.772 (45.0)	1.339 (34.0)	.079 (2.0)	.984 (25.0)	.472 (12.0)	.047 (1.2)	7.874 (200.0)
08	S08	1.969 (50.0)	1.969 (50.0)	1.575 (40.0)	.091 (2.3)	.984 (25.0)	.551 (14.0)	.059 (1.5)	7.874 (200.0)
09	S09	2.469 (62.7)	2.469 (62.7)	1.850 (47.0)	.100 (2.5)	1.00 (25.4)	.690 (17.5)	.059 (1.5)	8.000 (203.2)
10	S10	2.728 (69.3)	2.728 (69.3)	2.350 (59.7)	.100 (2.5)	1.00 (25.4)	.770 (19.6)	.059 (1.5)	8.000 (203.2)
11	S11	3.220 (81.8)	3.220 (81.8)	2.642 (67.1)	.100 (2.5)	1.00 (25.4)	.900 (22.9)	.059 (1.5)	8.000 (203.2)

For materials Type 2, Type 3 and Type 9, dimension 'Ce' is nominal

Lipped Straight Shrink Boots: Part Marking, Raised Lettering

EXPANDED

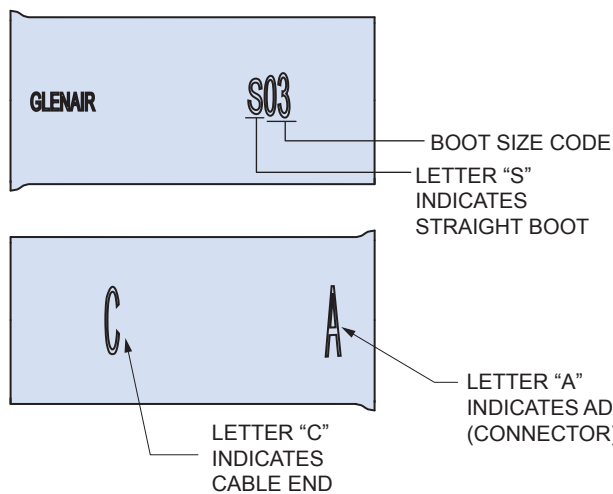

RECOVERED

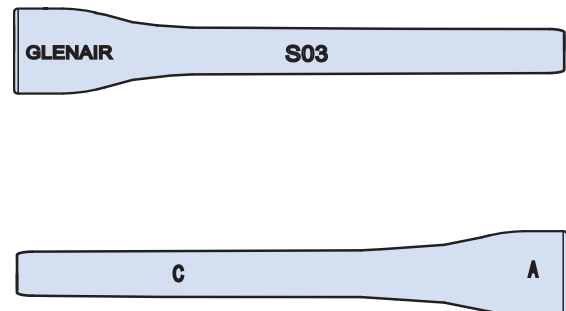



SERIES 77

Lipped, Straight Shrink Boots



770-020S TACOM Qualified Long Tail Boot How to Order

Straight Boots



TACOM qualified, lipped long tail straight shrink boots provide mechanical and environmental protection from damage and debris and additional strain relief compared to standard length boots and are available in three material options with five adhesive choices. Glenair straight boots fit most standard boot adapters for circular connectors. All adhesive lined and unlined shrink boots are RoHS compliant. Shrink boots are water-tight when equipped with factory installed or user-installed adhesive. Lipped boots lock into boot groove located on adapter and can be ordered with drain holes to fit your requirements. Choose boot size based on adapter diameter and cable diameter.

C

How to Order							
Sample Part Number	770	-020	S	6	03	W1	-DH
Product Series	770 = Series 77 shrink boot						
Basic Number	020 = lipped boot, long tail						
Angular Function	S = straight						
Material	See material and adhesives table						
Boot Size	02, 03, 04, 05, 06, 07, 08, 09, 10, 11; see dimensions table						
Adhesive Lined	Omit for no adhesive; see material and adhesives table						
Drain Holes	DH = drain hole Omit for none						

Material and Adhesive Compatibility						
Material Code	Material Description (Compound No.)	Hot Melt Adhesives			High Performance Epoxy Adhesives	
		W1	W2	W3 (TACOM approved)	R	U
		High Temperature -55°C to 125°C	Standard -55°C to 70°C	Elastomeric -55°C to 125°C	Pre-Coat -75°C to 150°C	Two-Part -75°C to 155°C
5	Viton Fluoroelastomer Blend (2050)	●		●	●	Type U epoxy adhesive is compatible with all boot materials. Ordered separately, user-installed (779-001). Order boot with no adhesive lining.
6	High Performance Elastomer Alloy (2051)	●		●		
7	Semi-Rigid Polyolefin (2071)	●	●			

TACOM Part Number Cross Reference					
Boot Size	Glenair Part Marking	Tacom Ref Part No.	Boot Size	Glenair Part Marking	Tacom Ref Part No.
02	S02	12273147-1*	07	S07	12273147-6*
03	S03	12273147-2*	08	S08	12273147-7*
04	S04	12273147-3*	09	S09	
05	S05	12273147-4*	10	S10	
06	S06	12273147-5*	11	S11	



SERIES 77

Lipped, Straight Shrink Boots



770-020S TACOM Qualified Long Tail Boot Dimensions

Lipped Straight Adapter Shrink Boots, Standard: Dimensions

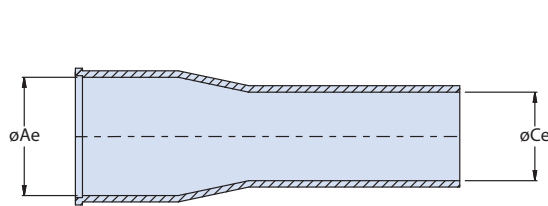

STRAIGHT - AS SUPPLIED

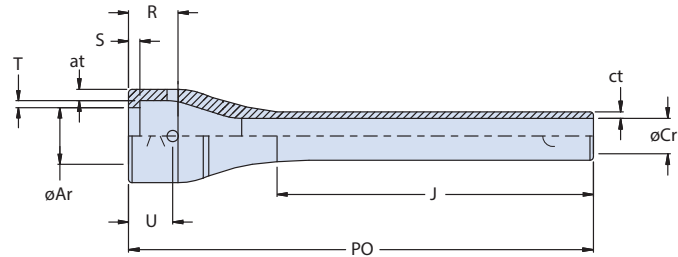

STRAIGHT - RECOVERED

Dimensions													
Boot Size	Glenair US Part Marking	Ae Dia. Min.	Ce Dia. Max.	Ar Dia. Max.	at $\pm .02/- .01$	Cr Dia. Max	ct $\pm .015$	PO $\pm 10\%$	S $\pm .06/- .00$	T $\pm .015$	R Min	J $\pm 10\%$	U $\pm 10\%$
02	S02	.940 (23.9)	.680 (17.3)	.390 (9.9)	.060 (1.5)	.260 (6.6)	.060 (1.5)	4.170 (105.9)	.060 (1.5)	.050 (1.3)	.460 (11.7)	3.400 (86.4)	.24 (6.1)
03	S03	1.070 (27.2)	.820 (20.8)	.520 (13.2)	.060 (1.5)	.300 (7.6)	.060 (1.5)	4.770 (121.2)	.060 (1.5)	.050 (1.3)	.480 (12.2)	3.880 (98.6)	.47 (11.9)
04	S04	1.220 (31.0)	.960 (24.4)	.730 (18.5)	.070 (1.8)	.350 (8.9)	.060 (1.5)	5.460 (138.7)	.060 (1.5)	.050 (1.3)	.480 (12.2)	4.440 (112.8)	.47 (11.9)
05	S05	1.400 (35.6)	1.130 (28.7)	.870 (22.1)	.070 (1.8)	.400 (10.2)	.060 (1.5)	6.280 (159.5)	.060 (1.5)	.050 (1.3)	.480 (12.2)	5.150 (130.8)	.47 (11.9)
06	S06	1.530 (38.9)	1.240 (31.5)	1.110 (28.2)	.070 (1.8)	.430 (10.9)	.060 (1.5)	7.000 (177.8)	.060 (1.5)	.070 (1.8)	.550 (14.0)	5.600 (142.2)	.47 (11.9)
07	S07	1.780 (45.2)	1.510 (38.4)	1.270 (32.3)	.070 (1.8)	.500 (12.7)	.060 (1.5)	8.000 (203.2)	.060 (1.5)	.070 (1.8)	.600 (15.2)	6.420 (163.1)	.47 (11.9)
08	S08	2.030 (51.6)	1.790 (45.5)	1.620 (41.1)	.070 (1.8)	.590 (15.0)	.070 (1.8)	8.000 (203.2)	.070 (1.8)	.070 (1.8)	.600 (15.2)	6.210 (157.7)	.63 (16.0)
09	S09	2.469 (62.7)	2.469 (62.7)	1.850 (47.0)	.100 (2.5)	.690 (17.5)	.070 (1.8)	8.000 (203.2)	.120 (3.0)	.080 (2.0)	1.00 (25.4)	6.00 (152)	.63 (16.0)
10	S10	2.728 (69.3)	2.728 (69.3)	2.350 (59.7)	.100 (2.5)	.770 (19.6)	.070 (1.8)	8.000 (203.2)	.120 (3.0)	.080 (2.0)	1.00 (25.4)	5.60 (142)	.63 (16.0)
11	S11	3.220 (81.8)	3.220 (81.8)	2.642 (67.1)	.100 (2.5)	.900 (22.9)	.070 (1.8)	8.000 (203.2)	.120 (3.0)	.080 (2.0)	1.00 (25.4)	5.40 (137)	.63 (16.0)

For materials Type 2, Type 3 and Type 9, dimension 'Ce' is nominal

Lipped Straight Shrink Boots: Part Marking, Raised Lettering

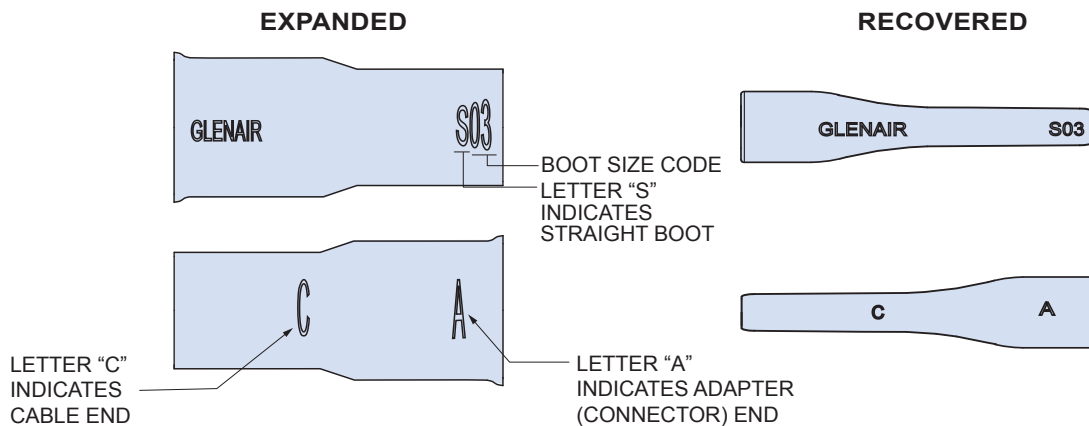



SERIES 77

Lipped, Straight Shrink Boots



770-007S High Ratio Boot
How to Order

Straight Boots



Lipped, hi-ratio straight heat shrink boots provide mechanical and environmental protection from damage and debris. Hi-ratio boots are an ideal solution where the connector/backshell is significantly larger than the cable being used. Boots are available in eight material options with five adhesive choices. Glenair straight boots fit most standard boot adapters for circular connectors. All adhesive lined and unlined shrink boots are RoHS compliant. Shrink boots are water-tight when equipped with factory installed or user-installed adhesive. Lipped boots lock into boot groove located on adapter and can be ordered with potting holes or drain holes according to your requirements. Choose boot size based on adapter diameter and cable diameter.

C

How to Order							
Sample Part Number	770	-007	S	1	03	W1	-DH
Product Series	770 = Series 77 shrink boot						
Basic Number	007 = high ratio lipped boot						
Angular Function	S = straight						
Material	See material and adhesives table						
Boot Size	03, 04, 06, 07; see dimensions table						
Adhesive Lined	Omit for no adhesive; see material and adhesives table						
Drain Holes or Potting Ports	DH = drain hole PP = injections-vent port Omit for none						

Material and Adhesive Compatibility						
Material Code	Material Description (Compound No.)	Hot Melt Adhesives			High Performance Epoxy Adhesives	
		W1	W2	W3 (TACOM approved)	R	U
		High Temperature -55°C to 125°C	Standard -55°C to 70°C	Elastomeric -55°C to 125°C	Pre-Coat -75°C to 150°C	Two-Part -75°C to 155°C
1	High-Performance Semi-Rigid Elastomer (2025)	●	●		●	Type U epoxy adhesive is compatible with all boot materials. Ordered separately, user-installed (779-001). Order boot with no adhesive lining.
2	Zero Halogen Semi-Rigid Polyolefin (2010)	●	●		●	
3	General Purpose Flexible Polyolefin (2040)		●			
5	Viton Fluoroelastomer Blend (2050)	●		●	●	
6	High Performance Elastomer Alloy (2051)	●		●		
7	Semi-Rigid Polyolefin (2071)	●	●			
8	Low Outgassing Fluoropolymer Alloy (2008)	Material Type 8 not available with pre-coat adhesive. Use Type U two-part epoxy				
9	Low Temp Flexible Polyolefin (2013)		●			

NOTES

- See **Modification Codes** listed in Section A for material color options available for **Type 1 (compound 2025)** material.
- Recovered dimension apply to unrestricted recovery. Dimensions may differ than shown when boots are installed over assembly.



SERIES 77
Lipped, Straight Shrink Boots
 770-007S High Ratio Boot
 Dimensions



Lipped Straight Adapter Shrink Boots, Standard: Dimensions

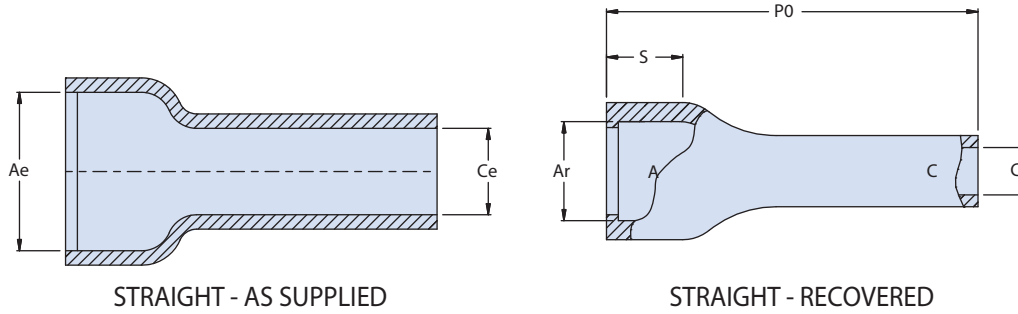

STRAIGHT - AS SUPPLIED

STRAIGHT - RECOVERED

Dimensions								
Boot Size	Glenair US Part Marking	AS85049/140 AS85049/141 Ref *	Ae Dia. Min	Ce Dia. Min	Ar Dia Max	Cr Dia. Max	PO ±10%	S Ref
03	S03	19	.760 (19.3)	.252 (6.4)	.512 (13.0)	.083 (2.1)	2.370 (60.2)	.461 (11.7)
04	S04	20	1.031 (26.2)	.299 (7.6)	.752 (19.1)	.102 (2.6)	2.921 (74.2)	.480 (12.2)
06	S06	21	1.350 (34.3)	.382 (9.7)	1.024 (26.0)	.122 (3.1)	3.319 (84.3)	.480 (12.2)
07	S07	22	1.720 (43.7)	.449 (11.4)	1.343 (34.1)	.142 (3.6)	3.921 (99.6)	.480 (12.2)

For materials Type 2, Type 3 and Type 9, dimension 'Ce' is nominal

*See GS85049/140 for mil qualified straight shrink boot

Lipped Straight Shrink Boots: Part Marking, Raised Lettering

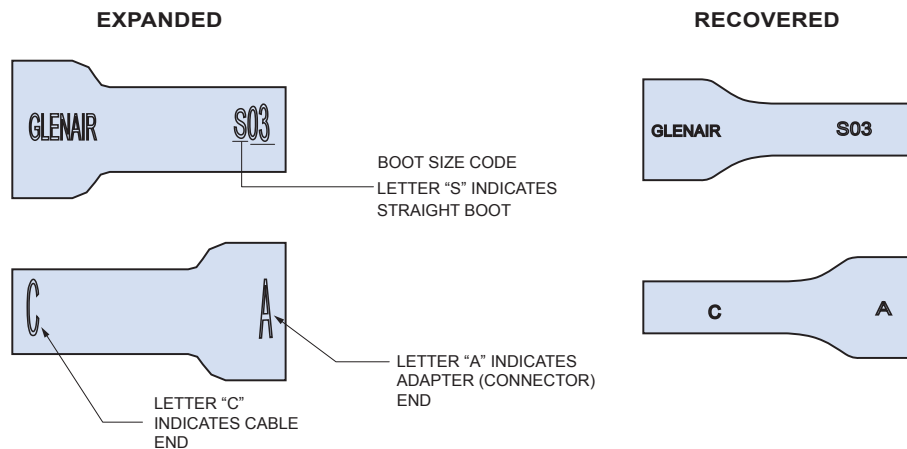



SERIES 77

Lipped, Straight Shrink Boots



770-008S NAVSEA Heavy Wall Boot
How to Order

Straight Boots



Lipped, straight shrink boots provide mechanical and environmental protection from damage and debris. Glenair straight boots fit most standard boot adapters for circular connectors. These heavy wall shrink boots are NAVSEA qualified and use zero-halogen polyolefin with a special W1 black adhesive. Lipped boots lock into boot groove located on adapter. Choose boot size based on adapter diameter and cable diameter.

C

How to Order	
Sample Part Number	770 -008 S 2 03 W1BLK
Product Series	770 = Series 77 shrink boot
Basic Number	008 = NAVSEA qualified, heavy wall lipped boot
Angular Function	S = straight
Material	2 = low smoke hazard material (compound 2010)
Part Size	00, 01, 02, 03, 04, 05
Adhesive Lined	W1BLK = 120°C zero halogen/hot melt, black Omit for none

Lipped Straight Shrink Boots: Part Marking, Raised Lettering

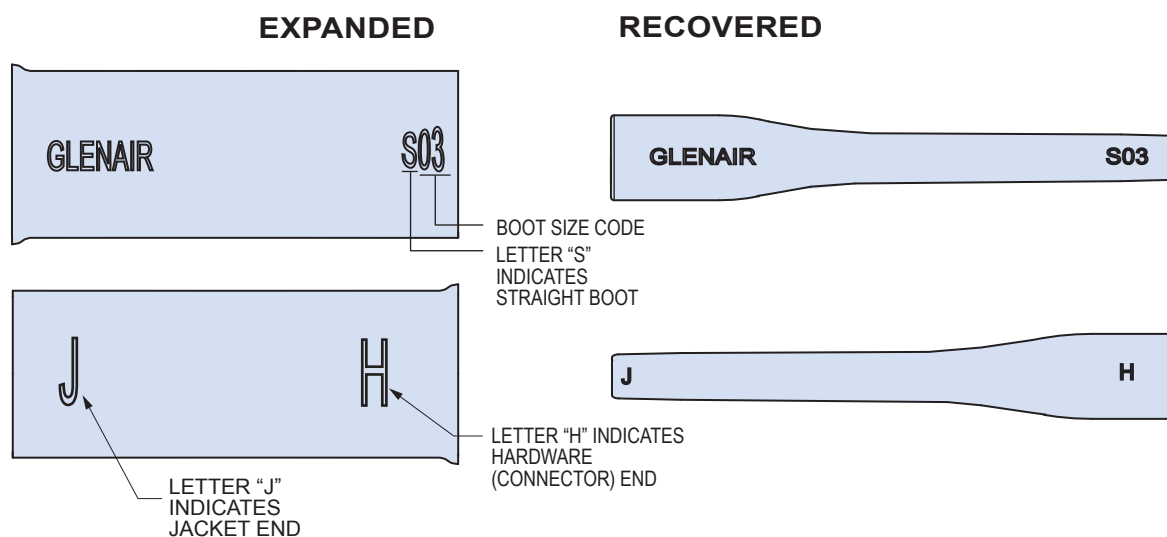



SERIES 77

Lipped, Straight Shrink Boots

770-008S NAVSEA Heavy Wall Boot Dimensions



Lipped Straight Adapter Shrink Boots, Standard: Dimensions

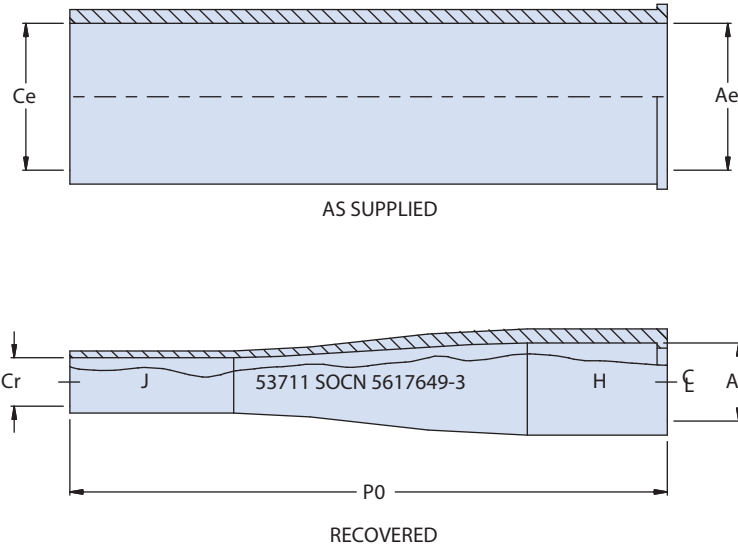

Straight Boots



770-008 Dimensions						
Size	NAVSEA Part No.	Ae Dia Min Expanded	Ar Dia Max Recovered	Ce Dia Min Expanded	Cr Dia max Recovered	P0 ±10%
00	5617649	.827 (21.0)	.551 (14.0)	.630 (16.0)	.209 (5.3)	5.315 (135.0)
01	5617649-1	.984 (25.0)	.650 (16.5)	.984 (25.0)	.331 (8.4)	6.024 (153.0)
02	5617649-2	1.299 (33.0)	.799 (20.3)	1.299 (33.0)	.429 (10.9)	6.024 (153.0)
03	5617649-3	1.693 (43.0)	.902 (22.9)	1.693 (43.0)	.559 (14.2)	6.890 (175.0)
04	5617649-4	2.087 (53.0)	1.098 (27.9)	2.087 (53.0)	.701 (17.8)	6.890 (175.0)
05	5617649-5	2.835 (72.0)	1.449 (36.8)	2.835 (72.0)	.949 (24.1)	7.244 (184.0)



SERIES 77

Lipped, Straight Shrink Boots



770-018S Commercial Heavy Wall Boot How to Order

Straight Boots



Lipped, heavy wall straight heat shrink boots provide mechanical and environmental protection from damage and debris. These heavy wall shrink boots are the commercial equivalent to our 770-008S NAVSEA qualified boots and are available in all eight materials and all five adhesive choices. Glenair straight boots fit most standard boot adapters for circular connectors. All adhesive lined and unlined shrink boots are RoHS compliant. Shrink boots are water-tight when equipped with factory installed or user-installed adhesive. Lipped boots lock into boot groove located on adapter. Choose boot size based on adapter diameter and cable diameter.

C

How to Order						
Sample Part Number		770	-018	S	1	03 W1
Product Series	770 = Series 77 shrink boot					
Basic Number	018 = heavy wall lipped boot					
Angular Function	S = straight					
Material	See material and adhesives table					
Boot Size	00, 01, 02, 03, 04, 05; see dimensions table					
Adhesive Lined	Omit for no adhesive; see material and adhesives table					

Material and Adhesive Compatibility							
Material Code	Material Description (Compound No.)	Hot Melt Adhesives			High Performance Epoxy Adhesives		
		W1	W2	W3 (TACOM approved)	R	U	
		High Temperature -55°C to 125°C	Standard -55°C to 70°C	Elastomeric -55°C to 125°C	Pre-Coat -75°C to 150°C	Two-Part -75°C to 155°C	
1	High-Performance Semi-Rigid Elastomer (2025)	●	●		●	Type U epoxy adhesive is compatible with all boot materials. Ordered separately, user-installed (779-001). Order boot with no adhesive lining.	
2	Zero Halogen Semi-Rigid Polyolefin (2010)	●	●		●		
3	General Purpose Flexible Polyolefin (2040)		●				
5	Viton Fluoroelastomer Blend (2050)	●		●	●		
6	High Performance Elastomer Alloy (2051)	●		●			
7	Semi-Rigid Polyolefin (2071)	●	●				
8	Low Outgassing Fluoropolymer Alloy (2008)	Material Type 8 not available with pre-coat adhesive. Use Type U two-part epoxy					
9	Low Temp Flexible Polyolefin (2013)		●				

NOTES

1. See **Modification Codes** listed in Section A for material color options available for **Type 1 (compound 2025)** material.
2. Recovered dimension apply to unrestricted recovery. Dimensions may differ than shown when boots are installed over assembly.



SERIES 77

Lipped, Straight Shrink Boots



770-018S Commercial Heavy Wall Boot Dimensions

Lipped Straight Adapter Shrink Boots, Standard: Dimensions

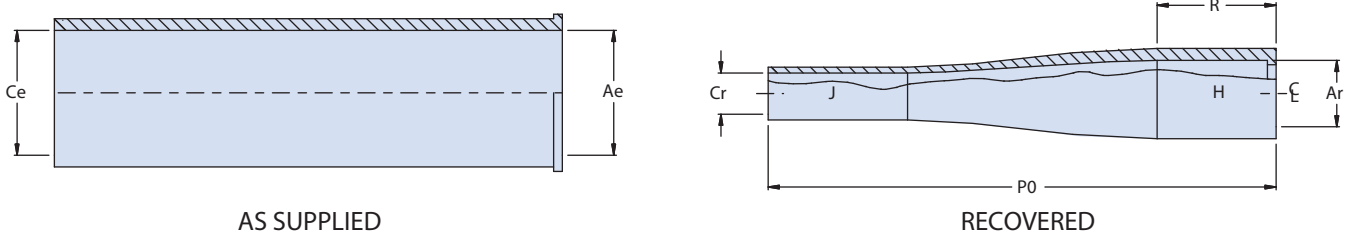

Dimensions								
Boot Size	Glenair Part Marking	AS858049/140 Fig 4 Reg	Ae Dia. Min Expanded	Ar Dia Max Recovered	Ce Dia. Min Expanded	Cr Dia. Max Recovered	PO ±10%	R ±10%
00	S00	23	.827 (21.0)	.551 (14.0)	.630 (16.0)	.209 (5.3)	5.315 (135.0)	1.10 (27.9)
01	S01	24	.984 (25.0)	.650 (16.5)	.984 (25.0)	.331 (8.4)	6.024 (153.0)	1.20 (30.5)
02	S02	25	1.299 (33.0)	.799 (20.3)	1.299 (33.0)	.429 (10.9)	6.024 (153.0)	1.20 (30.5)
03	S03	26	1.693 (43.0)	.902 (22.9)	1.693 (43.0)	.559 (14.2)	6.890 (175.0)	1.50 (38.1)
04	S04	27	2.087 (53.0)	1.098 (27.9)	2.087 (53.0)	.701 (17.8)	6.890 (175.0)	1.50 (38.1)
05	S05	28	2.835 (72.0)	1.449 (36.8)	2.835 (72.0)	.949 (24.1)	7.244 (184.0)	1.60 (40.6)

For materials Type 2, Type 3 and Type 9, dimension 'Ce' is nominal

Lipped Straight Shrink Boots: Part Marking, Raised Lettering

EXPANDED

RECOVERED

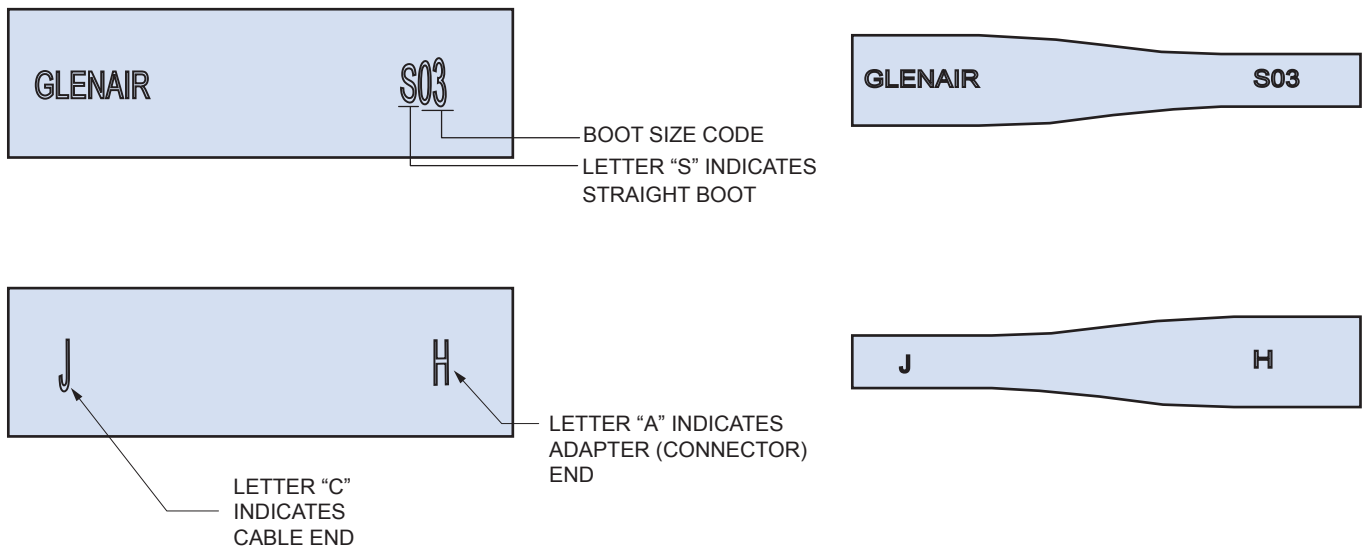



SERIES 77

Lipped, Straight Shrink Boots



770-022C Convoluted Boot
How to Order

Straight Boots



Lipped, convoluted straight heat shrink boots provide mechanical and environmental protection from damage and debris. Convoluted shrink boots have the added advantage of conforming to any angle from straight to 90°. These shrink boots fit most standard boot adapters for circular connectors. All adhesive lined and unlined shrink boots are RoHS compliant. Shrink boots are water-tight when equipped with factory installed or user-installed adhesive. Lipped boots lock into boot groove located on adapter. Choose boot size based on adapter diameter and cable diameter.

C

How to Order						
Sample Part Number		770	-022	C	1	03 W1
Product Series	770 = Series 77 shrink boot					
Basic Number	022 = lipped boot					
Boot Style	C = convoluted					
Material	See material and adhesives table					
Boot Size	00, 01, 02, 03, 04, 05, 06; see dimensions table					
Adhesive Lined	Omit for no adhesive; see material and adhesives table					

Material and Adhesive Compatibility							
Material Code	Material Description (Compound No.)	Hot Melt Adhesives			High Performance Epoxy Adhesives		
		W1	W2	W3 (TACOM approved)	R	U	
		High Temperature -55°C to 125°C	Standard -55°C to 70°C	Elastomeric -55°C to 125°C	Pre-Coat -75°C to 150°C	Two-Part -75°C to 155°C	
1	High-Performance Semi-Rigid Elastomer (2025)	●	●		●	Type U epoxy adhesive is compatible with all boot materials. Ordered separately, user-installed (779-001). Order boot with no adhesive lining.	
2	Zero Halogen Semi-Rigid Polyolefin (2010)	●	●		●		
3	General Purpose Flexible Polyolefin (2040)		●				
5	Viton Fluoroelastomer Blend (2050)	●		●	●		
6	High Performance Elastomer Alloy (2051)	●		●			
7	Semi-Rigid Polyolefin (2071)	●	●				
8	Low Outgassing Fluoropolymer Alloy (2008)	Material Type 8 not available with pre-coat adhesive. Use Type U two-part epoxy					
9	Low Temp Flexible Polyolefin (2013)		●				

NOTES

1. See **Modification Codes** listed in Section A for material color options available for **Type 1 (compound 2025)** material.
2. Recovered dimension apply to unrestricted recovery. Dimensions may differ than shown when boots are installed over assembly.



SERIES 77

Lipped, Straight Shrink Boots



770-022C Convoluted Boot Dimensions

Lipped Convoluted Adapter Shrink Boots: Dimensions

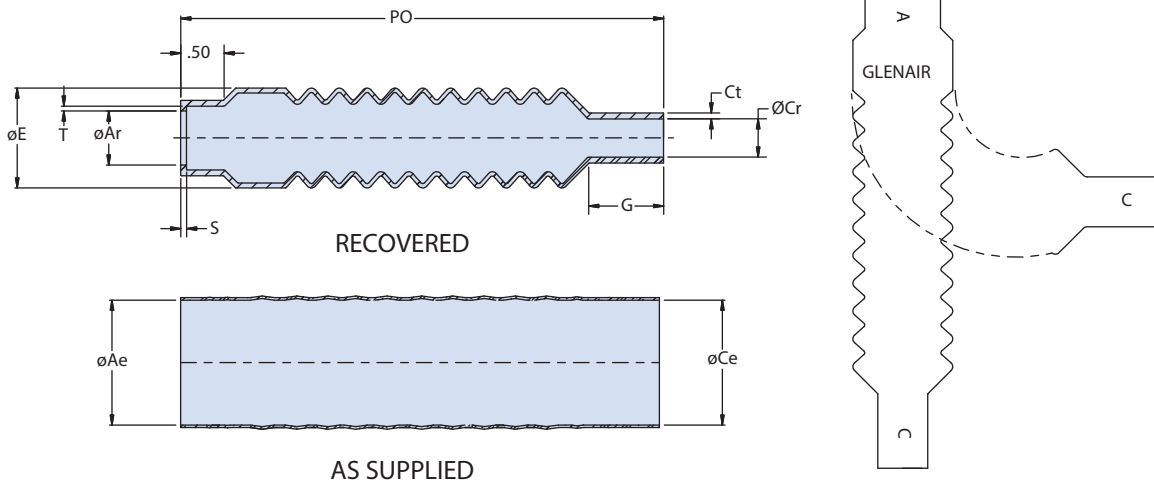

Straight Boots

C

Dimensions											
Boot Size	Part No.	Ae Dia. Min Expanded	Ar Dia Max Recovered	Ce Dia. Min Expanded	Cr Dia. Max Recovered	PO $\pm 10\%$	E Max	G $\pm 10\%$	S $\pm .010$	T $\pm .010$	Ct Min
00	C00	.500 (12.7)	.200 (5.1)	.500 (12.7)	.125 (3.2)	4.450 (113.0)	.715 (18.2)	.620 (15.7)	.040 (1.02)	.045 (1.14)	.013 (0.33)
01	C01	.690 (17.5)	.272 (6.9)	.560 (14.2)	.189 (4.8)	4.750 (120.7)	.830 (21.1)	.690 (17.5)	.040 (1.02)	.050 (1.27)	.013 (0.33)
02	C02	1.040 (26.4)	.461 (11.7)	1.040 (26.4)	.319 (8.1)	5.250 (133.4)	1.050 (26.7)	.780 (19.8)	.060 (1.52)	.050 (1.27)	.018 (0.46)
03	C03	1.500 (38.1)	.689 (17.5)	1.500 (38.1)	.500 (12.7)	5.750 (146.1)	1.290 (32.8)	.880 (22.4)	.070 (1.78)	.050 (1.27)	.020 (0.51)
04	C04	1.880 (47.8)	.882 (22.4)	1.880 (47.8)	.689 (17.5)	6.250 (158.8)	1.490 (37.8)	1.000 (25.4)	.070 (1.78)	.050 (1.27)	.024 (0.61)
05	C05	2.160 (54.9)	1.098 (27.9)	2.160 (54.9)	.882 (22.4)	6.750 (171.5)	1.690 (42.9)	1.120 (28.4)	.070 (1.78)	.080 (2.03)	.024 (0.61)
06	C06	2.250 (57.2) 3.040 (77.2) Type 7 only	1.598 (40.6)	2.250 (57.2)	.902 (22.9)	9.300 (236.2)	2.450 (62.2)	1.380 (35.1)	.080 (2.03)	.080 (2.03)	.026 (0.66)

For materials Type 2, Type 3 and Type 9, dimension 'Ce' is nominal

Lipped Straight Shrink Boots: Part Marking, Raised Lettering

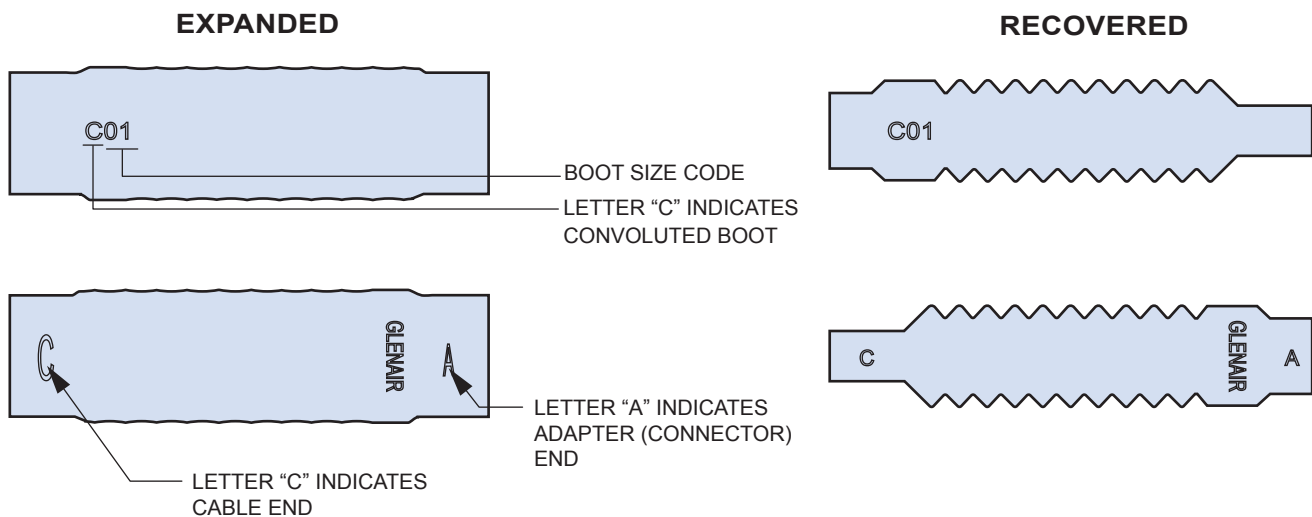



SERIES 77

Lipped, 90° Angle Shrink Boots



770-001A Angled Boot, with Eyelet
How to Order

90° Boots



Lipped, right angle heat shrink boots provide mechanical and environmental protection from damage and debris. These shrink boots fit most standard boot adapters for circular connectors. All adhesive lined and unlined shrink boots are RoHS compliant. Shrink boots are water-tight when equipped with factory installed or user-installed adhesive. These lipped boots come standard with eyelet for attachment of protective covers. Lipped boots lock into boot groove located on adapter. Choose boot size based on adapter diameter and cable diameter.

How to Order

Sample Part Number	770	-001	A	1	03	W1	-PP
Product Series	770 = Series 77 shrink boot						
Basic Number	001 = lipped boot with eyelet						
Angular Function	A = 90°						
Material	See material and adhesives table						
Boot Size	03, 04, 05, 06, 07, 08, 09; see dimensions table						
Adhesive Lined	Omit for no adhesive; see material and adhesives table						
Potting Port or Drain Hole	PP = potting port DH = standard drain holes DHS = drain holes 45° off center seam Omit for none						

Material and Adhesive Compatibility

Material Code	Material Description (Compound No.)	Hot Melt Adhesives			High Performance Epoxy Adhesives	
		W1	W2	W3 (TACOM approved)	R	U
		High Temperature -55°C to 125°C	Standard -55°C to 70°C	Elastomeric -55°C to 125°C	Pre-Coat -75°C to 150°C	Two-Part -75°C to 155°C
1	High-Performance Semi-Rigid Elastomer (2025)	●	●		●	Type U epoxy adhesive is compatible with all boot materials. Ordered separately, user-installed (779-001). Order boot with no adhesive lining.
2	Zero Halogen Semi-Rigid Polyolefin (2010)	●	●		●	
3	General Purpose Flexible Polyolefin (2040)		●			
5	Viton Fluoroelastomer Blend (2050)	●		●	●	
6	High Performance Elastomer Alloy (2051)	●		●		
7	Semi-Rigid Polyolefin (2071)	●	●			
8	Low Outgassing Fluoropolymer Alloy (2008)	Material Type 8 not available with pre-coat adhesive. Use Type U two-part epoxy				
9	Low Temp Flexible Polyolefin (2013)		●			

NOTES

1. See **Modification Codes** listed in Section A for material color options available for **Type 1 (compound 2025)** material.
2. Recovered dimension apply to unrestricted recovery. Dimensions may differ than shown when boots are installed over assembly.



SERIES 77

Lipped, 90° Angle Shrink Boots



770-001A Angled Boot, with Eyelet Dimensions

Lipped Right Angle Adapter Shrink Boots: Dimensions

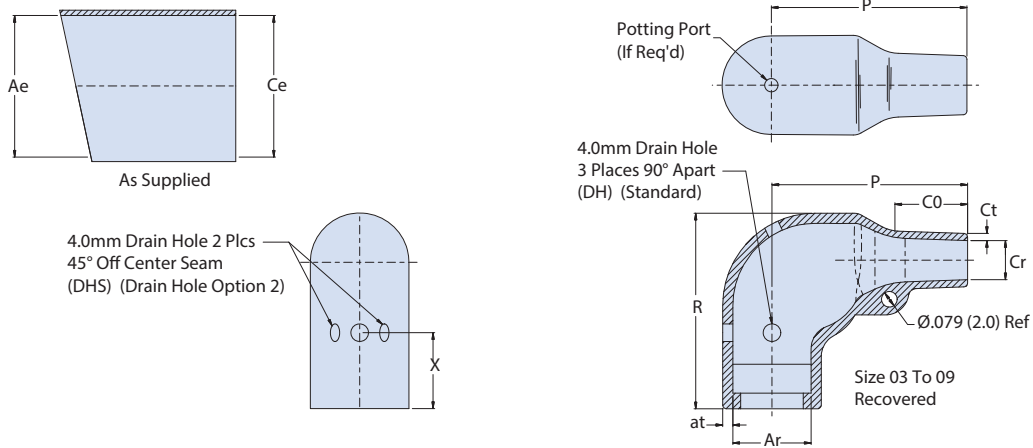

90° Boots

C

Dimensions												
Boot Size	Glenair US Part Marking	Shell Size	Ae DIA MIN	Ce DIA MIN	Ar DIA MAX	at ±30%	Cr DIA MAX	ct ±20%	CO REF	P±20%	R REF	X ±20%
03	A03	9	.945 (24.0)	.945 (24.0)	.394 (10.0)	.063 (1.6)	.197 (5.0)	.035 (0.9)	.394 (10.0)	.984 (25.0)	.984 (25.0)	.75 (19.0)
04	A04	11-15	1.181 (30.0)	1.181 (30.0)	.532 (13.5)	.071 (1.8)	.217 (5.5)	.039 (1.0)	.472 (12.0)	1.260 (32.0)	1.063 (27.0)	.87 (22.0)
05	A05	13-17	1.260 (32.0)	1.260 (32.0)	.709 (18.0)	.071 (1.8)	.276 (7.0)	.047 (1.2)	.591 (15.0)	1.535 (39.0)	1.260 (32.0)	.87 (22.0)
06	A06	17-21	1.417 (36.0)	1.417 (36.0)	.886 (22.5)	.079 (2.0)	.335 (8.5)	.047 (1.2)	.630 (16.0)	1.929 (49.0)	1.496 (38.0)	.87 (22.0)
07	A07	21-23	1.693 (43.0)	1.693 (43.0)	1.102 (28.0)	.087 (2.2)	.394 (10.0)	.059 (1.5)	.709 (18.0)	2.165 (55.0)	1.850 (47.0)	.87 (22.0)
08	A08	23-25	2.165 (55.0)	2.165 (55.0)	1.378 (35.0)	.130 (3.3)	.591 (15.0)	.079 (2.0)	1.260 (32.0)	3.150 (80.0)	2.165 (55.0)	.87 (22.0)
09	A09		2.599 (66.0)	2.599 (66.0)	1.752 (44.5)	.150 (3.8)	.661 (16.8)	.079 (2.0)	1.890 (48.0)	4.250 (108.0)	2.680 (68.0)	.87 (22.0)

For materials Type 2, Type 3 and Type 9, dimension 'Ce' is nominal

Lipped Right Angle Shrink Boots: Part Marking, Raised Lettering

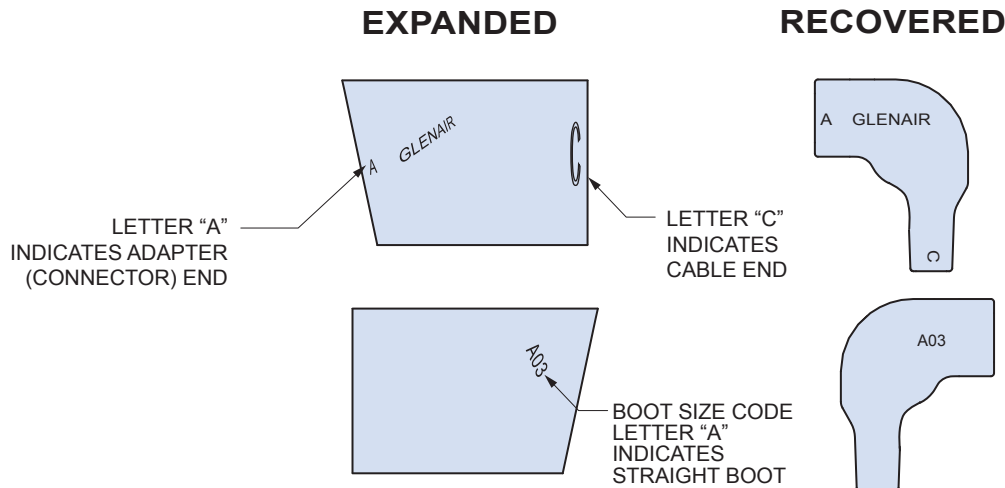



SERIES 77

Lipped, 90° Angle Shrink Boots



770-003A Angled Boot, No Eyelet
How to Order

90° Boots



Lipped, right angle heat shrink boots provide mechanical and environmental protection from damage and debris. These shrink boots fit most standard boot adapters for circular connectors. All adhesive lined and unlined shrink boots are RoHS compliant. Shrink boots are water-tight when equipped with factory installed or user-installed adhesive. Lipped boots lock into boot groove located on adapter. Choose boot size based on adapter diameter and cable diameter.

How to Order

Sample Part Number	770	-003	A	1	03	W1	-DH
Product Series	770 = Series 77 shrink boot						
Basic Number	003 = lipped boot						
Angular Function	A = 90°						
Material	See material and adhesives table						
Boot Size	02, 03, 04, 05, 06, 07, 08, 09; see dimensions table						
Adhesive Lined	Omit for no adhesive; see material and adhesives table						
Potting Port or Drain Hole	PP = potting port DH = drain holes Omit for none						

Material and Adhesive Compatibility

Material Code	Material Description (Compound No.)	Hot Melt Adhesives			High Performance Epoxy Adhesives		
		W1	W2	W3 (TACOM approved)	R	U	
		High Temperature -55°C to 125°C	Standard -55°C to 70°C	Elastomeric -55°C to 125°C	Pre-Coat -75°C to 150°C	Two-Part -75°C to 155°C	
1	High-Performance Semi-Rigid Elastomer (2025)	●	●		●	Type U epoxy adhesive is compatible with all boot materials. Ordered separately, user-installed (779-001). Order boot with no adhesive lining.	
2	Zero Halogen Semi-Rigid Polyolefin (2010)	●	●		●		
3	General Purpose Flexible Polyolefin (2040)		●				
5	Viton Fluoroelastomer Blend (2050)	●		●	●		
6	High Performance Elastomer Alloy (2051)	●		●			
7	Semi-Rigid Polyolefin (2071)	●	●				
8	Low Outgassing Fluoropolymer Alloy (2008)	Material Type 8 not available with pre-coat adhesive. Use Type U two-part epoxy					
9	Low Temp Flexible Polyolefin (2013)		●				

NOTES

1. See **Modification Codes** listed in Section A for material color options available for **Type 1 (compound 2025)** material.
2. Recovered dimension apply to unrestricted recovery. Dimensions may differ than shown when boots are installed over assembly.

AS85049/141 Cross Ref.

Boot Size	Glenair US Part Marking	AS85049/141 Ref
02	A02	
03	A03	01
04	A04	02
05	A05	03
06	A06	04
07	A07	05
08	A08	06
09	A09	07



SERIES 77

Lipped, 90° Angle Shrink Boots



770-003A Angled Boot, No Eyelet
Dimensions

Lipped Right Angle Adapter Shrink Boots: Dimensions

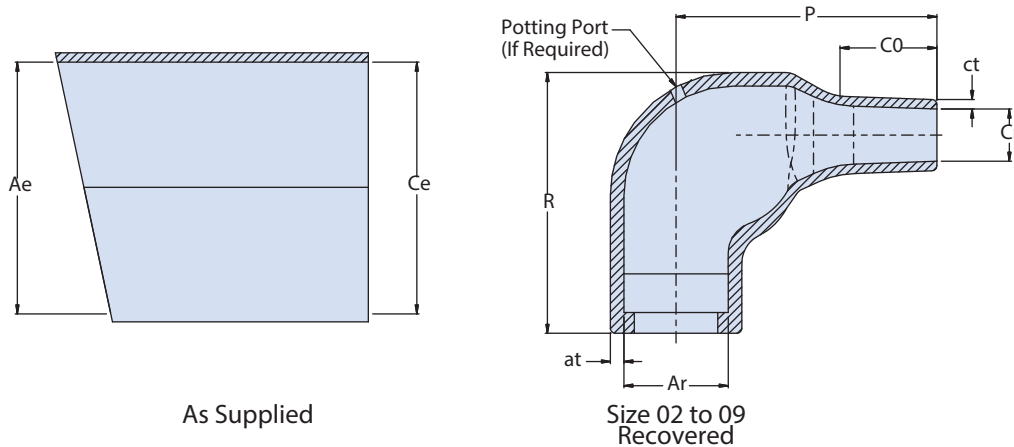

90° Boots

C

Dimensions										
Boot Size	Shell Size	Ae DIA MIN	Ce DIA MIN	Ar DIA MAX	at ±30%	Cr DIA MAX	ct ±20%	CO REF	P±20%	R Ref
02	7	.669 (17.0)	.669 (17.0)	.315 (8.0)	.051 (1.3)	.138 (3.5)	.028 (0.7)	.276 (7.0)	.787 (20.0)	.787 (20.0)
03	9	.945 (24.0)	.945 (24.0)	.394 (10.0)	.063 (1.6)	.197 (5.0)	.035 (0.9)	.394 (10.0)	.984 (25.0)	.984 (25.0)
04	11-15	1.181 (30.0)	1.181 (30.0)	.532 (13.5)	.071 (1.8)	.217 (5.5)	.039 (1.0)	.472 (12.0)	1.260 (32.0)	1.063 (27.0)
05	13-17	1.260 (32.0)	1.260 (32.0)	.709 (18.0)	.071 (1.8)	.276 (7.0)	.047 (1.2)	.591 (15.0)	1.535 (39.0)	1.260 (32.0)
06	17-21	1.417 (36.0)	1.417 (36.0)	.886 (22.5)	.079 (2.0)	.335 (8.5)	.047 (1.2)	.630 (16.0)	1.929 (49.0)	1.496 (38.0)
07	21-23	1.693 (43.0)	1.693 (43.0)	1.102 (28.0)	.087 (2.2)	.394 (10.0)	.059 (1.5)	.709 (18.0)	2.165 (55.0)	1.850 (47.0)
08	23-25	2.165 (55.0)	2.165 (55.0)	1.378 (35.0)	.130 (3.3)	.591 (15.0)	.079 (2.0)	1.260 (32.0)	3.150 (80.0)	2.165 (55.0)
09	25-33	2.599 (66.0)	2.599 (66.0)	1.752 (44.5)	.150 (3.8)	.661 (16.8)	.079 (2.0)	1.890 (48.0)	4.250 (108.0)	2.680 (68.0)

For materials Type 2, Type 3 and Type 9, dimension 'Ce' is nominal

Lipped Right Angle Shrink Boots: Part Marking, Raised Lettering

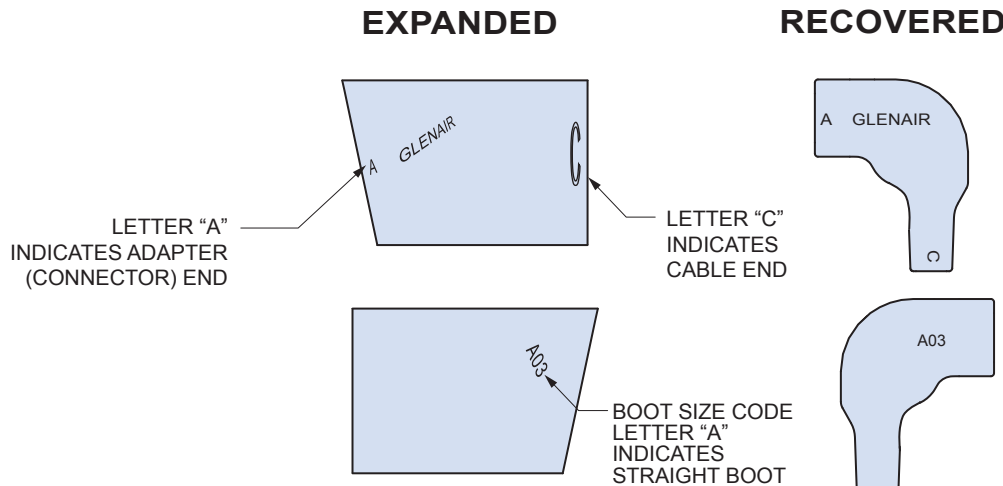



SERIES 77

Lipped, 90° Angle Shrink Boots



770-006A Angled Long Tail Boot
How to Order

90° Boots



Lipped long tail, right angle heat shrink boots provide mechanical and environmental protection from damage and debris. Long tail boots provide additional strain relief compared to standard length boots. These shrink boots fit most standard boot adapters for circular connectors. All adhesive lined and unlined shrink boots are RoHS compliant. Shrink boots are water-tight when equipped with factory installed or user-installed adhesive. Lipped boots lock into boot groove located on adapter. Choose boot size based on adapter diameter and cable diameter.

How to Order

Sample Part Number	770	-006	A	1	03	W1	-PP
Product Series	770 = Series 77 shrink boot						
Basic Number	006 = lipped, long tail boot						
Angular Function	A = 90°						
Material	See material and adhesives table						
Boot Size	01, 02, 03, 04, 05, 06, 07, 08, 09; see dimensions table						
Adhesive Lined	Omit for no adhesive; See material and adhesives table						
Potting Port or Drain Hole	PP = potting port DH = drain holes Omit for none						

Material and Adhesive Compatibility

Material Code	Material Description (Compound No.)	Hot Melt Adhesives			High Performance Epoxy Adhesives	
		W1	W2	W3 (TACOM approved)	R	U
		High Temperature -55°C to 125°C	Standard -55°C to 70°C	Elastomeric -55°C to 125°C	Pre-Coat -75°C to 150°C	Two-Part -75°C to 155°C
1	High-Performance Semi-Rigid Elastomer (2025)	●	●		●	Type U epoxy adhesive is compatible with all boot materials. Ordered separately, user-installed (779-001). Order boot with no adhesive lining.
2	Zero Halogen Semi-Rigid Polyolefin (2010)	●	●		●	
3	General Purpose Flexible Polyolefin (2040)		●			
5	Viton Fluoroelastomer Blend (2050)	●		●	●	
6	High Performance Elastomer Alloy (2051)	●		●		
7	Semi-Rigid Polyolefin (2071)	●	●			
8	Low Outgassing Fluoropolymer Alloy (2008)	Material Type 8 not available with pre-coat adhesive. Use Type U two-part epoxy				
9	Low Temp Flexible Polyolefin (2013)		●			

NOTES

- See **Modification Codes** listed in Section A for material color options available for **Type 1 (compound 2025)** material.
- Recovered dimension apply to unrestricted recovery. Dimensions may differ than shown when boots are installed over assembly.

AS85049/141 Part No Cross Ref.

Boot Size	Glenair Part Marking	AS85049/140 AS85049/141*	Boot Size	Glenair Part Marking	AS85049/140 AS85049/141*
01	A01		06	A06	13
02	A02	09	07	A07	14
03	A03	10	08	A08	15
04	A04	11	09	A09	16
05	A05	12			

*See GS85049/141 for mil qualified 90° shrink boots



SERIES 77

Lipped, 90° Angle Shrink Boots



770-006A Angled Long Tail Boot Dimensions

Lipped Right Angle Adapter Shrink Boots: Dimensions

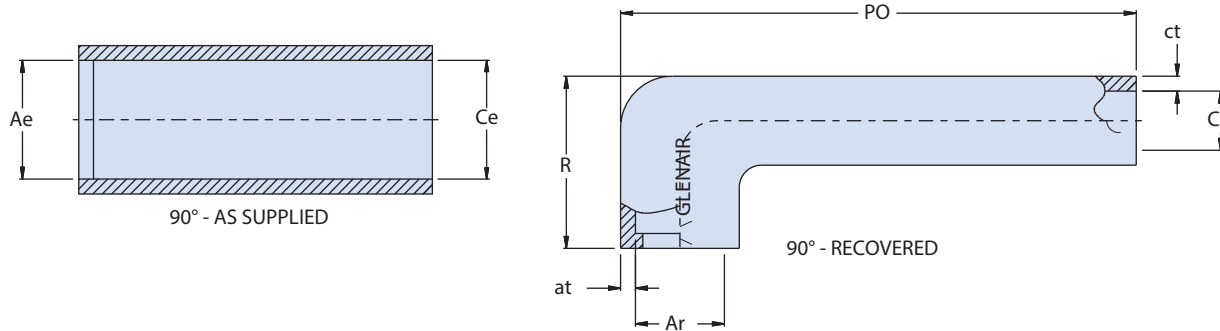

90° Boots

C

Dimensions									
Boot Size	Ae DIA MIN	Ce DIA MIN	Ar DIA MAX	at ±30%	A0 Ref	Cr DIA MAX	ct ±20%	PO ±10% 90°	R REF
01	.620 (15.7)	.620 (15.7)	.290 (7.4)	.054 (1.37)	.500 (12.7)	.125 (3.17)	.043 (1.1)	4.000 (101.6)	.558 (14.2)
02	.886 (22.5)	.886 (22.5)	.433 (11.0)	.059 (1.5)	.551 (14.0)	.256 (6.5)	.047 (1.2)	4.142 (105.2)	.728 (18.5)
03	.984 (25.0)	.984 (25.0)	.591 (15.0)	.059 (1.5)	.591 (15.0)	.295 (7.5)	.047 (1.2)	4.882 (124.0)	.780 (19.8)
04	1.181 (30.0)	1.181 (30.0)	.748 (19.0)	.071 (1.8)	.591 (15.0)	.335 (8.5)	.047 (1.2)	5.760 (146.3)	.819 (20.8)
05	1.378 (35.0)	1.378 (35.0)	.827 (21.0)	.071 (1.8)	.787 (20.0)	.374 (9.5)	.047 (1.2)	6.780 (172.2)	.858 (21.8)
06	1.476 (37.5)	1.476 (37.5)	1.181 (30.0)	.079 (2.0)	.787 (20.0)	.413 (10.5)	.047 (1.2)	7.291 (185.2)	.961 (24.4)
07	1.772 (45.0)	1.772 (45.0)	1.339 (34.0)	.079 (2.0)	.984 (25.0)	.472 (12.0)	.047 (1.2)	8.409 (213.6)	1.079 (27.4)
08	1.969 (50.0)	1.969 (50.0)	1.575 (40.0)	.091 (2.3)	.984 (25.0)	.551 (14.0)	.059 (1.5)	8.839 (224.5)	1.161 (29.5)
09	2.469 (62.7)	2.469 (62.7)	1.850 (47.0)	.100 (2.5)	1.00 (25.4)	.690 (17.5)	.059 (1.5)	8.949 (227.3)	1.311 (33.3)

For materials Type 2, Type 3 and Type 9, dimension 'Ce' is nominal

Lipped Right Angle Shrink Boots: Part Marking, Raised Lettering

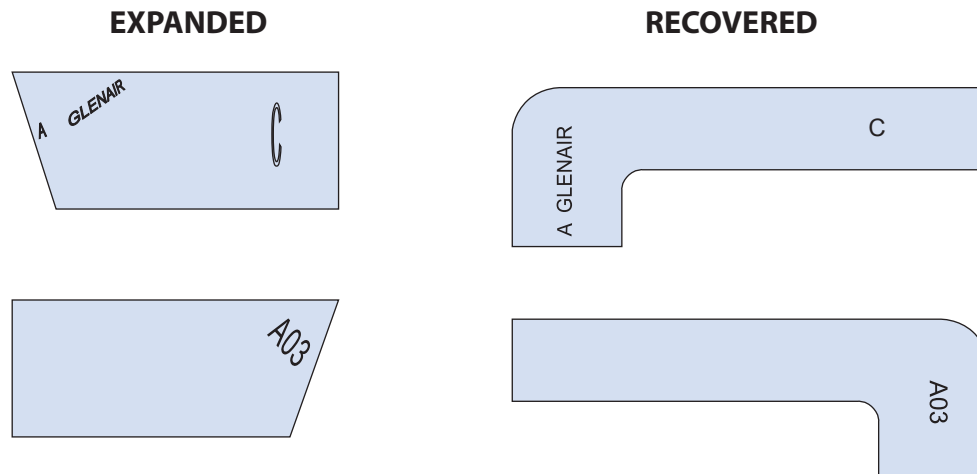



SERIES 77

Lipped, 90° Angle Shrink Boots



770-021A Angled Long Tail Boot

Qualified to TACOM 12273176 - How to Order

90° Boots



Lipped long tail, right angle heat shrink boots provide mechanical and environmental protection from damage and debris. Long tail boots provide additional strain relief compared to standard length boots. These shrink boots fit most standard boot adapters for circular connectors. All adhesive lined and unlined shrink boots are RoHS compliant. Shrink boots are water-tight when equipped with factory installed or user-installed adhesive. Lipped boots lock into boot groove located on adapter. Choose boot size based on adapter diameter and cable diameter.

How to Order

Sample Part Number	770	-021	A	6	03	W1	-DH
Product Series	770 = Series 77 shrink boot						
Basic Number	021 = lipped, long tail boot						
Angular Function	A = 90°						
Material	See material and adhesive table						
Boot Size	02, 03, 04, 05, 06, 07, 08, 09; see dimensions table						
Adhesive Lined	Omit for no adhesive; see adhesive table for options						
Drain Hole	DH = drain holes Omit for none						

Material and Adhesive Compatibility

Material Code	Material Description (Compound No.)	Hot Melt Adhesives			High Performance Epoxy Adhesives	
		W1	W2	W3 (TACOM approved)	R	U
		High Temperature -55°C to 125°C	Standard -55°C to 70°C	Elastomeric -55°C to 125°C	Pre-Coat -75°C to 150°C	Two-Part -75°C to 155°C
5	Viton Fluoroelastomer Blend (2050)	●		●	●	Type U epoxy adhesive is compatible with all boot materials. Ordered separately, user-installed (779-001). Order boot with no adhesive lining.
6	High Performance Elastomer Alloy (2051)	●		●		
7	Semi-Rigid Polyolefin (2071)	●	●			

NOTES

- See **Modification Codes** listed in Section A for material color options available for **Type 1 (compound 2025)** material.
- Per AS85049 3 places 90° apart and one on top.
- Recovered dimension apply to unrestricted recovery. Dimensions may differ than shown when boots are installed over assembly.

Part Number Cross Reference

Boot Size	Glenair US Part Marking	Tacom Ref Part No
02	A02	12273176-1*
03	A03	12273176-2*
04	A04	12273176-3*
05	A05	12273176-4*
06	A06	12273176-5*
07	A07	12273176-6*
08	A08	12273176-7*
09	A09	12273176-8*



SERIES 77

Lipped, 90° Angle Shrink Boots



770-021A Angled Long Tail Boot

Qualified to TACOM 12273176 - Dimensions

Lipped Right Angle Shrink Boots: Dimensions

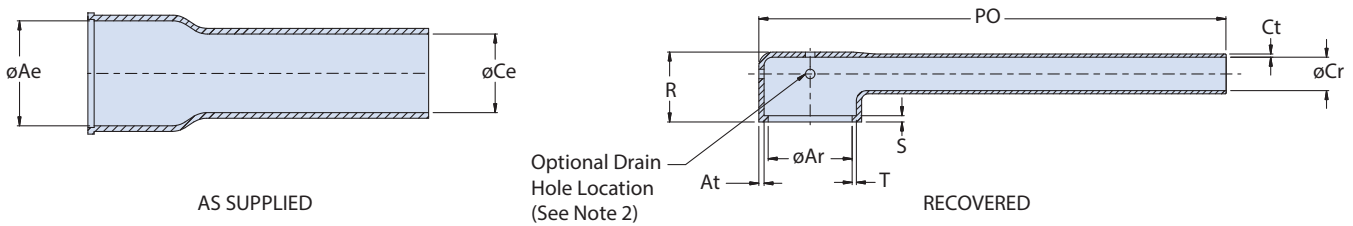

90° Boots

C

Dimensions											
Boot Size	Ae Dia Min	Ce Dia Min	Ar Dia Max	At + .02/- .01	Cr Dia Max	ct ±.015	PO ±10%	S +.06/- .00	t .015±	R ±10%	
02	.940(23.9)	.680(17.3)	.390(9.9)	.060(1.52)	.260(6.6)	.060(1.52)	4.142(105.2)	.060(1.52)	.050(1.27)	.730(18.5)	
03	1.070(27.2)	.820(20.8)	.520(13.2)	.060(1.52)	.300(7.6)	.060(1.52)	4.882(124.0)	.060(1.52)	.050(1.27)	.780(19.8)	
04	1.220(31.0)	.960(24.4)	.730(18.5)	.070(1.78)	.350(8.9)	.060(1.52)	5.760(146.3)	.070(1.78)	.050(1.27)	.820(20.8)	
05	1.400(35.6)	1.130(28.7)	.870(22.1)	.070(1.78)	.400(10.2)	.060(1.52)	6.780(172.2)	.070(1.78)	.050(1.27)	.860(21.8)	
06	1.530(38.9)	1.240(31.5)	1.110(28.2)	.070(1.78)	.430(10.9)	.060(1.52)	7.291(185.2)	.070(1.78)	.070(1.78)	.960(24.4)	
07	1.780(45.2)	1.510(38.4)	1.270(32.3)	.070(1.78)	.500(12.7)	.060(1.52)	8.409(213.6)	.070(1.78)	.070(1.78)	1.08(27.4)	
08	2.030(51.6)	1.750(44.5)	1.620(41.1)	.080(2.03)	.590(15.0)	.070(1.78)	8.839(224.5)	.070(1.78)	.070(1.78)	1.16(29.5)	
09	2.470(62.7)	1.860(47.2)	1.690(42.9)	.085(2.16)	.690(17.5)	.070(1.78)	8.949(227.3)	.070(1.78)	.080(2.03)	1.31(33.3)	

Lipped Right Angle Shrink Boots: Part Marking, Raised Lettering

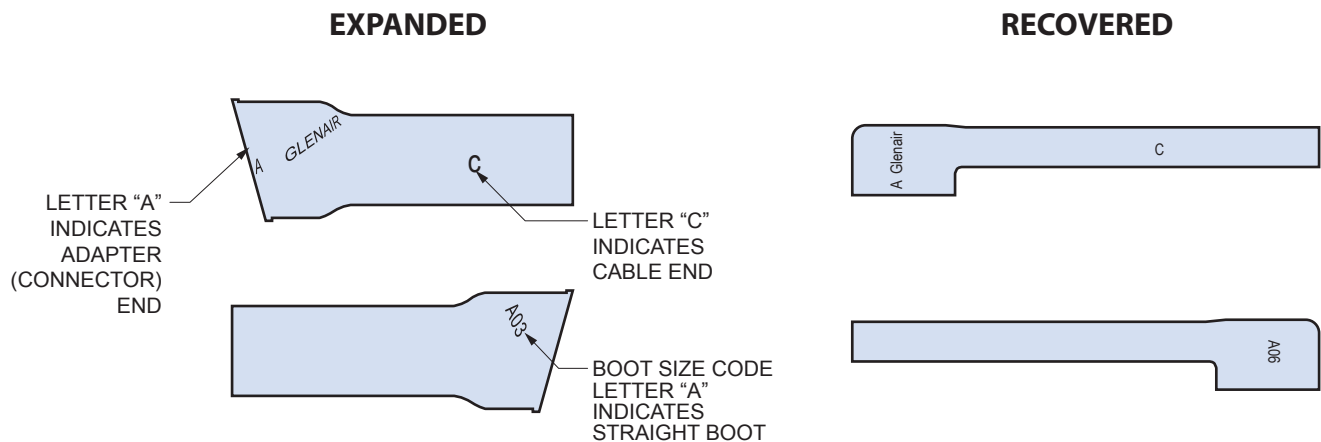



SERIES 77

Lipped, 90° Angle Shrink Boots



770-007A Angled Long Tail Boot
How to Order

90° Boots



Lipped, right angle, long tail heat shrink boots provide mechanical and environmental protection from damage and debris. Long tail boots provide additional strain relief compared to standard length boots. These shrink boots fit most standard boot adapters for circular connectors. All adhesive lined and unlined shrink boots are RoHS compliant. Shrink boots are water-tight when equipped with factory installed or user-installed adhesive. Lipped boots lock into boot groove located on adapter. Choose boot size based on adapter diameter and cable diameter.

How to Order

Sample Part Number	770	-007	A	1	03	W1	-PP
Product Series	770 = Series 77 shrink boot						
Basic Number	007 = lipped, long tail boot						
Angular Function	A = 90°						
Material	See adhesive table for options						
Boot Size	03, 04, 06, 07; see dimensions table						
Adhesive Lined	Omit for no adhesive; see adhesive table for options						
Potting Port or Drain Hole	PP = potting port DH = drain holes Omit for none						

Material and Adhesive Compatibility

Material Code	Material Description (Compound No.)	Hot Melt Adhesives			High Performance Epoxy Adhesives		
		W1	W2	W3 (TACOM approved)	R	U	
		High Temperature -55°C to 125°C	Standard -55°C to 70°C	Elastomeric -55°C to 125°C	Pre-Coat -75°C to 150°C	Two-Part -75°C to 155°C	
1	High-Performance Semi-Rigid Elastomer (2025)	●	●		●	Type U epoxy adhesive is compatible with all boot materials. Ordered separately, user-installed (779-001). Order boot with no adhesive lining.	
2	Zero Halogen Semi-Rigid Polyolefin (2010)	●	●		●		
3	General Purpose Flexible Polyolefin (2040)		●				
5	Viton Fluoroelastomer Blend (2050)	●		●	●		
6	High Performance Elastomer Alloy (2051)	●		●			
7	Semi-Rigid Polyolefin (2071)	●	●				
8	Low Outgassing Fluoropolymer Alloy (2008)	Material Type 8 not available with pre-coat adhesive. Use Type U two-part epoxy					
9	Low Temp Flexible Polyolefin (2013)		●				

NOTES

1. See **Modification Codes** listed in Section A for material color options available for **Type 1 (compound 2025)** material.
2. Recovered dimension apply to unrestricted recovery. Dimensions may differ than shown when boots are installed over assembly.



SERIES 77

Lipped, 90° Angle Shrink Boots



770-007A Angled Long Tail Boot Dimensions

Lipped Right Angle Shrink Boots: Dimensions

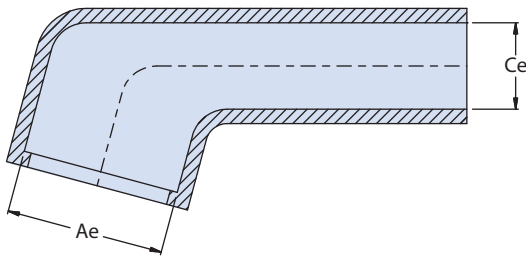

90° - AS SUPPLIED

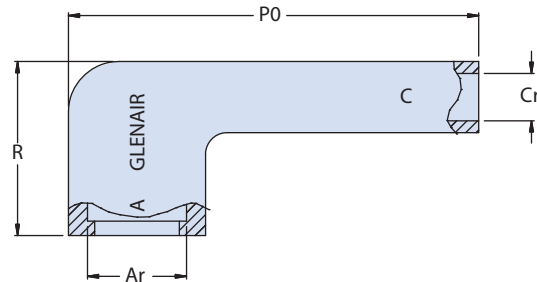

90° - RECOVERED

90° Boots

C

Dimensions								
Boot Size	Glenair US Part Marking	AS85049/141 Ref ²	Ae Dia. Min	Ce Dia. Min	Ar Dia Max	Cr Dia. Max	PO ±10%	R Ref
03	A03	19	.760 (19.3)	.252 (6.4)	.512 (13.0)	.083 (2.1)	1.772 (45.0)	.630 (16.0)
04	A04	20	1.031 (26.2)	.299 (7.6)	.752 (19.1)	.102 (2.6)	2.642 (67.1)	.709 (18.0)
06	A06	21	1.350 (34.3)	.382 (9.7)	1.024 (26.0)	.122 (3.1)	3.189 (81.0)	.752 (19.1)
07	A07	22	1.720 (43.7)	.449 (11.4)	1.343 (34.1)	.142 (3.6)	4.571 (116.1)	.831 (21.1)

For materials Type 2, Type 3 and Type 9, dimension 'Ce' is nominal

Lipped Right Angle Shrink Boots: Part Marking, Raised Lettering

EXPANDED

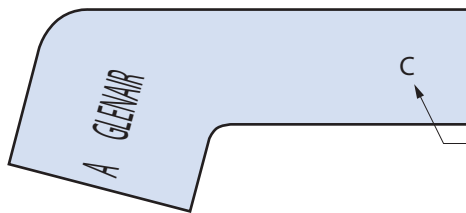

LETTER "C" INDICATES CABLE END



RECOVERED

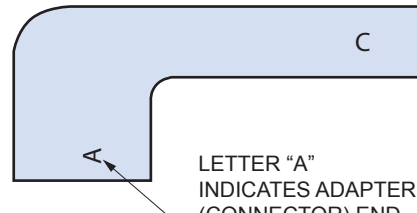

LETTER "A" INDICATES ADAPTER (CONNECTOR) END

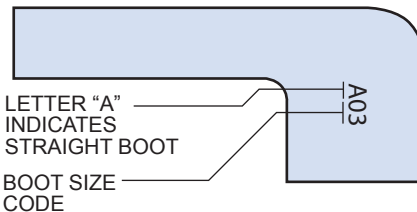

LETTER "A" INDICATES STRAIGHT BOOT
BOOT SIZE CODE



SERIES 77

Lipped, 45° Angle Shrink Boots



770-001B Angled Boot with Eyelet
How to Order

45° Boots



Lipped, 45° angle heat shrink boots provide mechanical and environmental protection from damage and debris. These shrink boots fit most standard boot adapters for circular connectors. All adhesive lined and unlined shrink boots are RoHS compliant. Shrink boots are water-tight when equipped with factory installed or user-installed adhesive. Lipped boots lock into boot groove located on adapter. Choose boot size based on adapter diameter and cable diameter.

How to Order

Sample Part Number	770	-001	B	1	03	W1	-PP
Product Series	770 = Series 77 shrink boot						
Basic Number	001 = lipped, boot with eyelet						
Angular Function	B = 45°						
Material	See adhesive table for options						
Boot Size	03, 04, 05, 06, 07; see dimensions table						
Adhesive Lined	Omit for no adhesive; see adhesive table for options						
Potting Port	PP = potting port Omit for none						

Material and Adhesive Compatibility

Material Code	Material Description (Compound No.)	Hot Melt Adhesives			High Performance Epoxy Adhesives		
		W1	W2	W3 (TACOM approved)	R	U	
		High Temperature -55°C to 125°C	Standard -55°C to 70°C	Elastomeric -55°C to 125°C	Pre-Coat -75°C to 150°C	Two-Part -75°C to 155°C	
1	High-Performance Semi-Rigid Elastomer (2025)	●	●		●	Type U epoxy adhesive is compatible with all boot materials. Ordered separately, user-installed (779-001). Order boot with no adhesive lining.	
2	Zero Halogen Semi-Rigid Polyolefin (2010)	●	●		●		
3	General Purpose Flexible Polyolefin (2040)		●				
5	Viton Fluoroelastomer Blend (2050)	●		●	●		
6	High Performance Elastomer Alloy (2051)	●		●			
7	Semi-Rigid Polyolefin (2071)	●	●				
8	Low Outgassing Fluoropolymer Alloy (2008)	Material Type 8 not available with pre-coat adhesive. Use Type U two-part epoxy					
9	Low Temp Flexible Polyolefin (2013)		●				

NOTES

1. See **Modification Codes** listed in Section A for material color options available for **Type 1 (compound 2025)** material.
2. Recovered dimension apply to unrestricted recovery. Dimensions may differ than shown when boots are installed over assembly.



SERIES 77

Lipped, 45° Angle Shrink Boots



770-001B Angled Boot with Eyelet Dimensions

Lipped 45° Angle Shrink Boots: Dimensions

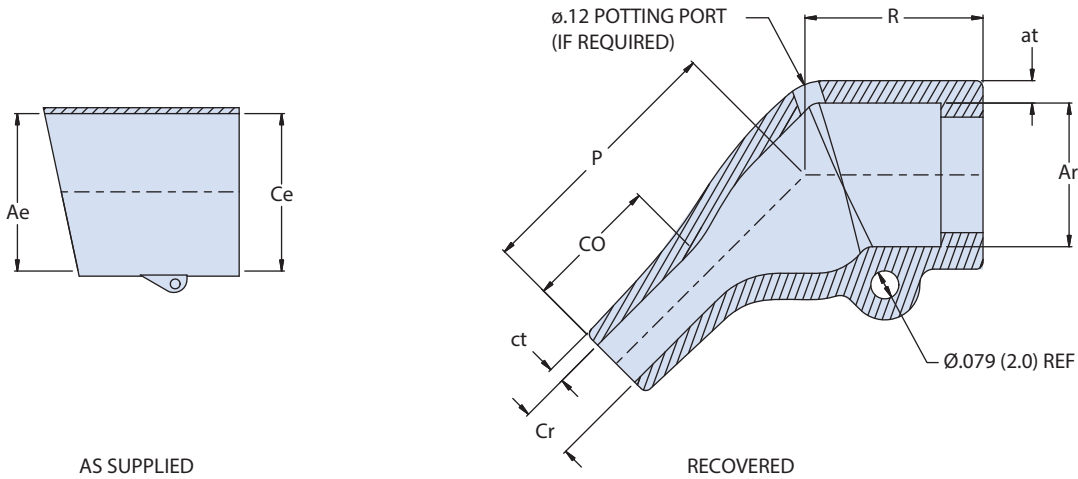

45° Boots



Dimensions											
Boot Size	Glenair US Part Marking	Shell Size	Ae Dia. Min	Ce Dia. Min	Ar Dia Max	at $\pm 30\%$	Cr Dia. Max	ct $\pm 20\%$	CO Ref	P $\pm 10\%$	R Ref
03	B03	9	.945 (24.0)	.945 (24.0)	.413 (10.5)	.063 (1.6)	.157 (4.0)	.035 (0.9)	.315 (8.0)	.748 (19.0)	.500 (12.7)
04	B04	11-15	1.181 (30.0)	1.181 (30.0)	.551 (14.0)	.071 (1.8)	.236 (6.0)	.039 (1.0)	.354 (9.0)	1.180 (30.0)	.748 (19.0)
05	B05	13-17	1.260 (32.0)	1.260 (32.0)	.709 (18.0)	.079 (2.0)	.276 (7.0)	.071 (1.8)	.591 (15.0)	1.378 (35.0)	.984 (25.0)
06	B06	17-21	1.417 (36.0)	1.417 (36.0)	.866 (22.0)	.079 (2.0)	.335 (8.5)	.071 (1.8)	.709 (18.0)	1.575 (40.0)	1.260 (32.0)
07	B07	21-23	1.693 (43.0)	1.693 (43.0)	1.102 (28.0)	.087 (2.2)	.394 (10.0)	.079 (2.0)	.709 (18.0)	1.772 (45.0)	1.496 (38.0)

Lipped 45° Angle Shrink Boots: Part Marking, Raised Lettering

EXPANDED

RECOVERED

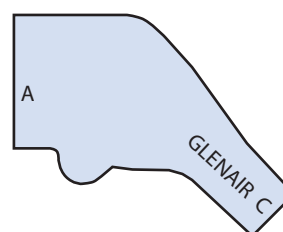
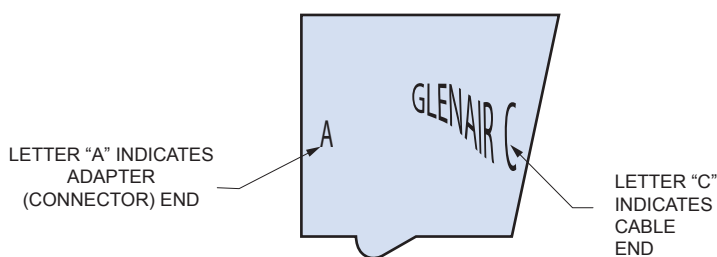
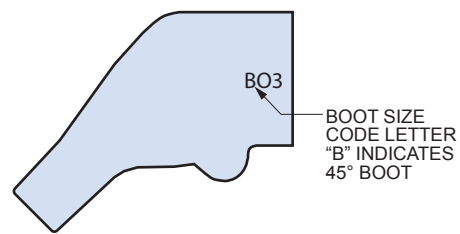
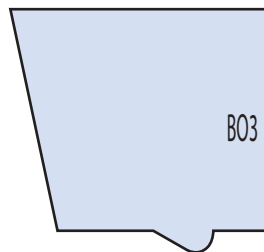



SERIES 77 Lipped, 45° Angle Shrink Boots



770-003B Angled Boot How to Order

45° Boots



Lipped, 45° angle heat shrink boots provide mechanical and environmental protection from damage and debris. These shrink boots fit most standard boot adapters for circular connectors. All adhesive lined and unlined shrink boots are RoHS compliant. Shrink boots are water-tight when equipped with factory installed or user-installed adhesive. Lipped boots lock into boot groove located on adapter. Choose boot size based on adapter diameter and cable diameter.

How to Order

Sample Part Number		770	-003	B	1	03	W1	-PP
Product Series	770 = Series 77 shrink boot							
Basic Number	003 = lipped, boot							
Angular Function	B = 45°							
Material	See material and adhesive compatibility table							
Boot Size	03, 04, 05, 06, 07; see dimensions table							
Adhesive Lined	Omit for no adhesive; see material and adhesive compatibility table							
Potting Port	PP = potting port Omit for none							

Material and Adhesive Compatibility

Material Code	Material Description (Compound No.)	Hot Melt Adhesives			High Performance Epoxy Adhesives		
		W1	W2	W3 (TACOM approved)	R	U	
		High Temperature -55°C to 125°C	Standard -55°C to 70°C	Elastomeric -55°C to 125°C	Pre-Coat -75°C to 150°C	Two-Part -75°C to 155°C	
1	High-Performance Semi-Rigid Elastomer (2025)	●	●		●	Type U epoxy adhesive is compatible with all boot materials. Ordered separately, user-installed (779-001). Order boot with no adhesive lining.	
2	Zero Halogen Semi-Rigid Polyolefin (2010)	●	●		●		
3	General Purpose Flexible Polyolefin (2040)		●				
5	Viton Fluoroelastomer Blend (2050)	●		●	●		
6	High Performance Elastomer Alloy (2051)	●		●			
7	Semi-Rigid Polyolefin (2071)	●	●				
8	Low Outgassing Fluoropolymer Alloy (2008)	Material Type 8 not available with pre-coat adhesive. Use Type U two-part epoxy					
9	Low Temp Flexible Polyolefin (2013)		●				

NOTES

1. See **Modification Codes** listed in Section A for material color options available for **Type 1 (compound 2025)** material.
2. Recovered dimension apply to unrestricted recovery. Dimensions may differ than shown when boots are installed over assembly.



SERIES 77

Lipped, 45° Angle Shrink Boots



770-003B Angled Boot Dimensions

Lipped 45° Angle Shrink Boots: Dimensions

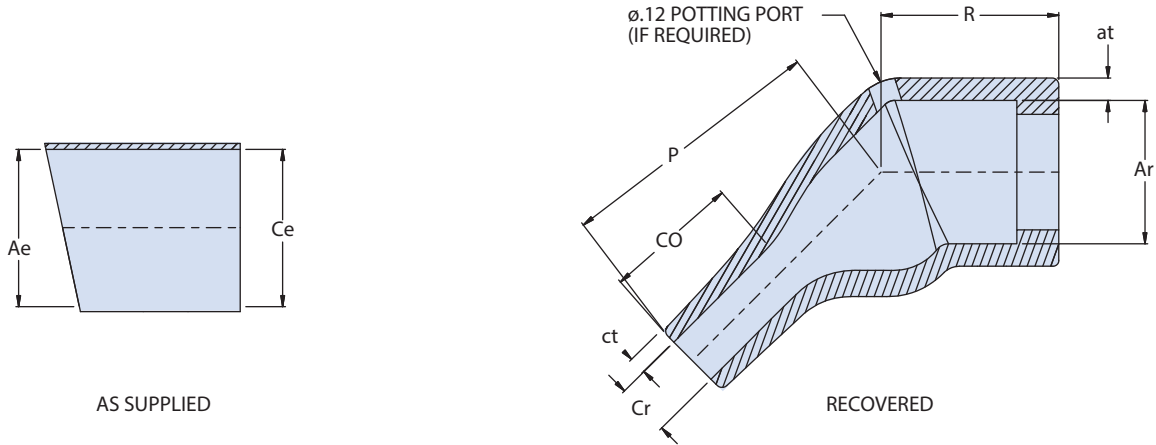

45° Boots

C

Dimensions											
Boot Size	Glenair US Part Marking	Shell Size	Ae Dia. Min	Ce Dia. Min	Ar Dia Max	at ±30%	Cr Dia. Max	ct ±20%	CO Ref	P ±10%	R Ref
03	B03	9	.945 (24.0)	.945 (24.0)	.413 (10.5)	.063 (1.6)	.157 (4.0)	.035 (0.9)	.315 (8.0)	.748 (19.0)	.500 (12.7)
04	B04	11 - 15	1.181 (30.0)	1.181 (30.0)	.551 (14.0)	.071 (1.8)	.236 (6.0)	.039 (1.0)	.354 (9.0)	1.180 (30.0)	.748 (19.0)
05	B05	13 - 17	1.260 (32.0)	1.260 (32.0)	.709 (18.0)	.079 (2.0)	.276 (7.0)	.071 (1.8)	.591 (15.0)	1.378 (35.0)	.984 (25.0)
06	B06	17 - 21	1.417 (36.0)	1.417 (36.0)	.866 (22.0)	.079 (2.0)	.335 (8.5)	.071 (1.8)	.709 (18.0)	1.575 (40.0)	1.260 (32.0)
07	B07	21 - 23	1.693 (43.0)	1.693 (43.0)	1.102 (28.0)	.087 (2.2)	.394 (10.0)	.079 (2.0)	.709 (18.0)	1.772 (45.0)	1.496 (38.0)

Lipped 45° Angle Shrink Boots: Part Marking, Raised Lettering

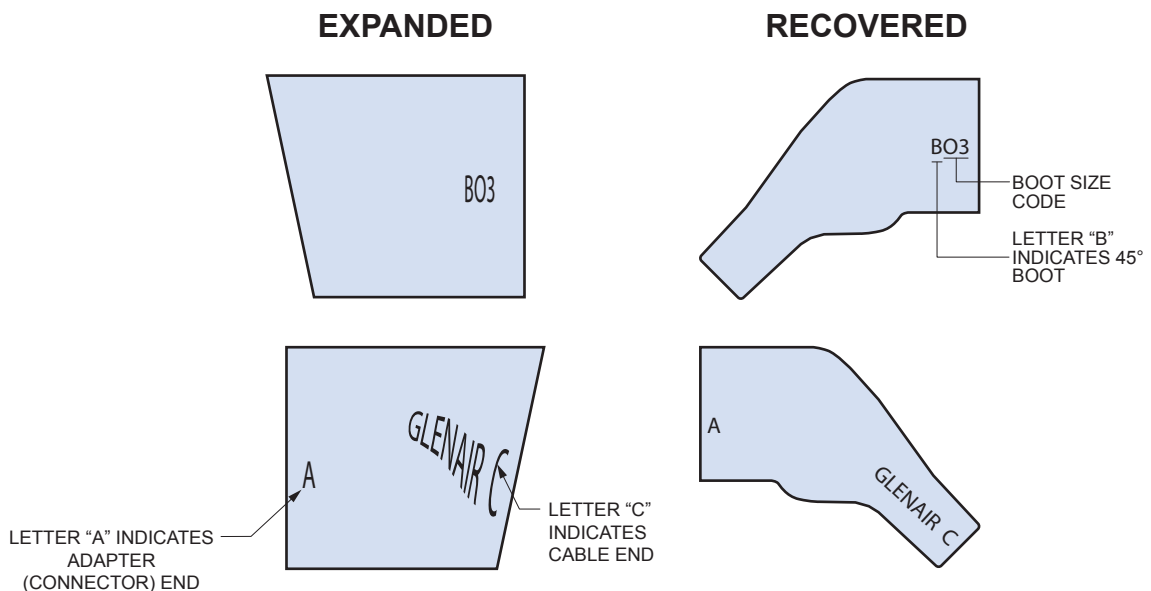

SERIES 77
LIPLLESS HEAT
SHRINK BOOTS

LIPLLESS BOOTS

Environmental sealing and strain relief for direct attachment to connectors without boot adapter

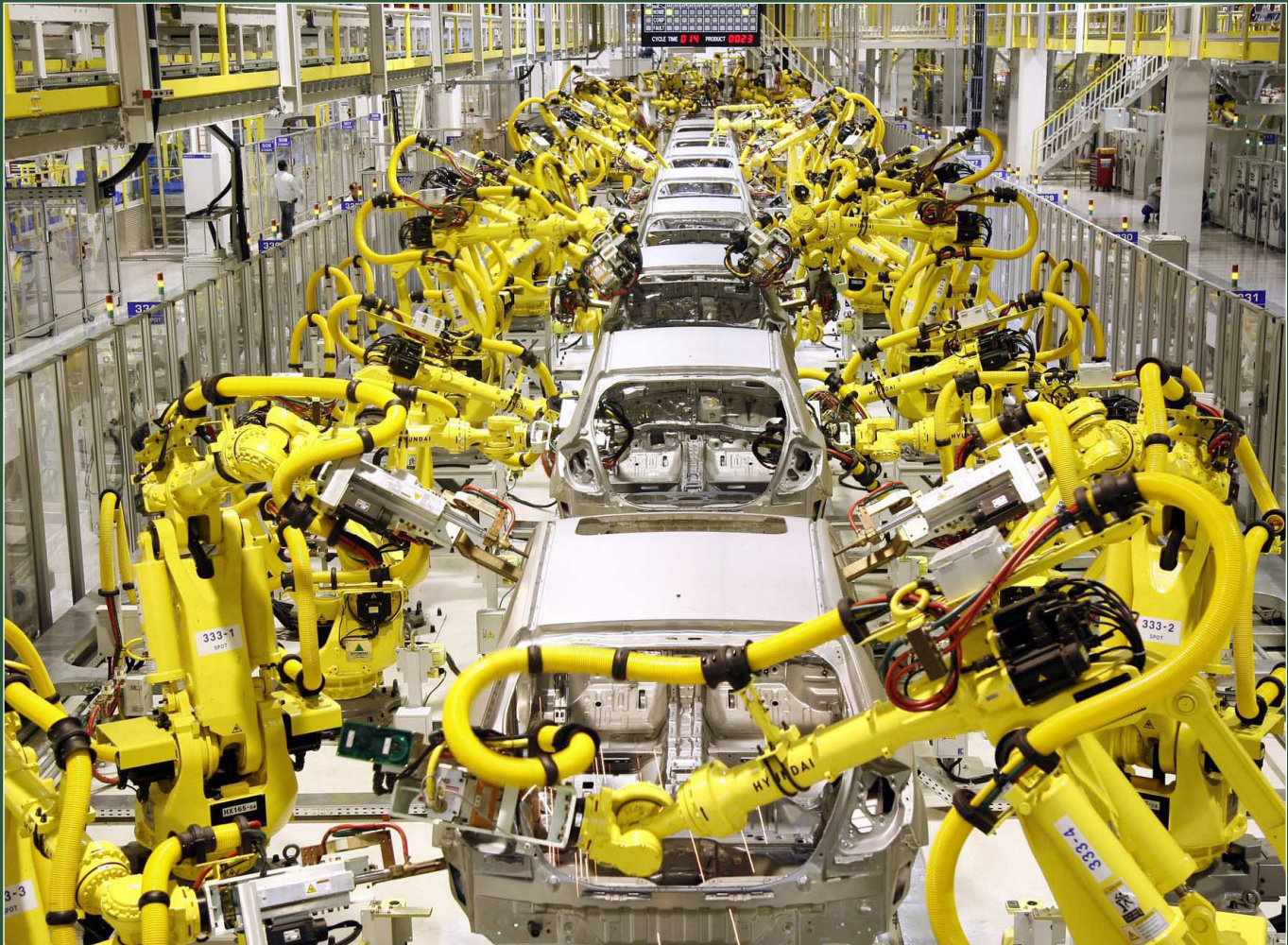

Series 77 lipless heat shrink boots provide excellent protection from environmental debris while providing strain relief and withstanding harsh work environments where exposure to fuels, solvents and other fluids is likely. Lipless boots require no adapter, and adhere directly onto the threaded rear interface of connector providing a low profile solution. Shrink boots are available in 8 material types, including low smoke/zero halogen, low outgassing fluoropolymer, Viton®, and high performance elastomer. Boots are available pre-coated with or without adhesive.



Glenair, Inc.
1211 Air Way
Glendale, CA 91201-2497
818-247-6000
sales@glenair.com
www.glenair.com





SERIES 77
Lipless Boots
Product Selection Guide



Shrink Boot Selection and Reference Guide D-2



Straight Shrink Boots.....D-4



Straight Shim Shrink bootsD-8



Right Angle Shrink Boots D-10

D



SERIES 77 Lipless Boots



Shrink Boot Reference and Selection Guide

Lipless Straight and 45° Angle Shrink Boots



- *Direct attachment to standard circular connectors*
- *Eight material options*
- *Four adhesive options*
- *Optional potting ports*
- *Non-adhesive lined boots (For use with Type U two-part epoxy):*

Lipless shrink boots are designed to shrink down around the accessory threads of a circular connector, doing away with the need for any additional adapter hardware. These connectors provide a space and weight saving solution with a lower profile than traditional lipped boots. Lipless boots are available in straight and 90° angle configurations. Shrink boots provide environmental and mechanical protection as well as wire strain relief.

Recommended Material Selection

Type 1 high performance, semi-rigid elastomer for extreme temperatures and excellent resistance to fuels and oils and rated for 3000 hours continuous operation at +150°C. Material meets requirements of VG95343 Type 6, BSG 198-5-DE, EN62329-102 and SAE AS5258 Type H. Temperature rating -75°C to 150°C

Type 2 semi-flexible low smoke zero halogen (LSZH) flame-retarded polyolefin meets low smoke and toxicity requirements of shipboard, transit and aircraft systems and rated for 3000 hours continuous operation at +130° C. Temperature rating -40° C to +130°C. Material meets the requirements of SAE AS5258 Type G.

Type 3 self extinguishing, flexible polyolefin boots meet SAE AS8176581 Type II requirements and offers good resistance to oils and fuels. Good all around general duty shrink boot solution. Temperature rating of -55° C to +135°C. Material Meets the Requirements of SAE AS5258 Type B.

Type 5 flexible Viton® fluoroelastomer boot for extreme temperatures where excellent resistance to fuels, fluids, solvents is needed. Temperature rating of -55° C to +150°C. Material meets the requirements of SC-X15111D.

Type 6 high performance, flexible elastomer alloy are well suited for high temperatures within areas prone to oil and fluid exposure. Temperature rating of -55° to +135°C. Material meets the requirements of SC-X15112C.

Type 7 highly flexible polyolefin boots are well suited for high temperatures within areas prone to oil and fluid exposure. Temperature rating of -55° to +135°C. Material meets the requirements of SAE AS5258 Type A.

Type 8 semi-rigid, low outgassing fluoropolymer alloy meets NASA low out-gassing test requirements and are suitable for high altitude and space applications. Excellent resistance to oils, fuels, solvents, acids and bases. Broad operating temperature of -50° C to +175° C provides excellent high temperature stability and low temperature flexibility for extreme temperatures. The recommended Adhesive is 779-001 two-part epoxy.

Type 9 low temp application, flexible polyolefin for Ethernet and USB cables susceptible to heat damage from the application of boots with higher minimum shrink temperatures. Resistance to oils, fuels, solvents, acids and bases is fair. Temperature rating of -40° to +100°C.



Part Number
779-001



Part Number
779-002



Part Number	Package Size
779-003	12

D



SERIES 77 Lipless Boots



Shrink Boot Material and Adhesive Selection Guide

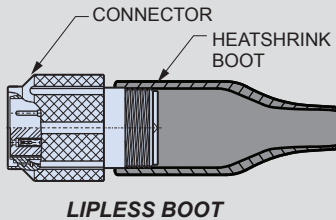

Boot Size	Connector Diameter				Min. Cable Diameter		Boot Size	Connector Diameter				Min. Cable Diameter	
	Inches		Millimeters		In.	mm.		Inches		Millimeters		In.	mm.
	Min	Max	Min	Max				Min	Max	Min	Max		
00	.250	.325	6.35	8.26	.110	2.79	06	.900	1.350	22.86	34.29	.375	9.53
01	.300	.425	7.62	10.80	.150	3.81	07	1.250	1.650	31.75	41.91	.425	10.80
02	.350	.600	8.89	15.24	.175	4.45	08	1.400	2.250	35.56	57.15	.625	15.88
03	.450	.850	11.43	21.59	.225	5.72	09	1.800	2.500	45.70	63.50	.800	20.30
04	.600	1.000	15.24	25.40	.275	6.99	10	2.370	3.200	60.20	81.30	1.120	28.50
05	.750	1.200	19.05	30.48	.300	7.62							

Material Type	Flexibility	Continuous Operating Temp.	Resistance to Fuels, Oils	Flammability	Low Temperature Flexibility	Low Toxicity, Zero Halogen
Type 1 High-Performance Semi-Rigid Elastomer	Semi-rigid	-75° C to +150° C	Excellent	Self-Extinguishing <15 Sec	-75° C	No
Type 2 Zero Halogen Semi-Rigid Polyolefin	Semi-flexible	-40° C to +130° C	Very Good	Self-Extinguishing <15 Sec	-40° C	Yes
Type 3 General Purpose Flexible Polyolefin	Flexible	-55° C to +135° C	Good	Self-Extinguishing <120 Sec	-55° C	No
Type 5 Viton Fluoroelastomer Blend	Flexible	-55° C to +150° C	Excellent	Self-Extinguishing <60 Sec	-55° C	No
Type 6 High Performance Elastomer Alloy	Flexible	-55° C to +135° C	Excellent	Self-Extinguishing <60 Sec	-55° C	No
Type 7 Semi-Rigid Polyolefin	Highly Flexible	-55° C to +135° C	Good	Self-Extinguishing <60 Sec	-55° C	No
Type 8 Low Outgassing Fluoropolymer Alloy	Semi-Rigid	-50° C to +175° C	Excellent	Self-Extinguishing <60 Sec	-50° C	No
Type 9 Low Temp Flexible Polyolefin	Flexible	-40° C to +100° C	Fair	Self-Extinguishing <120 Sec	-40° C	No

Attribute	W1 High Performance Adhesive	W2 Low Temp Adhesive	W3 TACOM Approved Adhesive	R High Performance Epoxy Adhesive	779-001 Two Part Epoxy Adhesive
Boot Material Compatibility	Types 1, 2, 5, 6 and 7	Types 1, 2, 3, 7 and 9	Types 5 and 6	Type 1, 2 and 5	All Material Types
Continuous Operating Temp.	-55° to +125°C	-55° to +70°C	-55° to +125°C	-75° to +150°C	-75° to +150°C
Resistance to Fuels, Oils, and Fluids	Good	Good	Good	Excellent	Excellent
Low Toxicity, Zero Halogen	Yes	Yes	No	Yes	Yes



SERIES 77 Lipless Boots



770-005S Straight Boot How to Order



Lipless, straight shrink boots provide mechanical and environmental protection from damage and debris. Straight boots are available in eight material options with five adhesive choices. Glenair straight boots are made in accordance with AS85045 and fit most circular connectors. All adhesive lined and unlined shrink boots are RoHS compliant. Shrink boots are water-tight when equipped with factory installed or user-installed adhesive. Lipless boots bind to accessory threads at rear of connector without an additional adapter resulting in a lower profile and can be ordered with potting holes to fit your requirements. Choose boot size based on connector's rear thread diameter and cable diameter.

D

How to Order							
Sample Part Number	770	-005	S	1	03	W1	-PP
Product Series	770 = Series 77 shrink boot						
Basic Number	005 = lipless boot without eyelet						
Angular Function	S = straight						
Material	See material and adhesives table						
Boot Size	00, 01, 02, 03, 04, 05, 06, 07, 08, 09, 10; see shell size cross reference in dimensions table						
Adhesive Lined	Omit for none; see material and adhesives table						
Potting Port	PP = potting port						

Material and Adhesive Compatibility							
Material Code	Material Description (Compound No.)	Hot Melt Adhesives			High Performance Epoxy Adhesives		
		W1	W2	W3 (TACOM approved)	R	U	
		High Temperature -55°C to 125°C	Standard -55°C to 70°C	Elastomeric -55°C to 125°C	Pre-Coat -75°C to 150°C	Two-Part -75°C to 155°C	
1	High-Performance Semi-Rigid Elastomer (2025)	●	●		●	Type U epoxy adhesive is compatible with all boot materials. Ordered separately, user-installed (779-001). Order boot with no adhesive lining.	
2	Zero Halogen Semi-Rigid Polyolefin (2010)	●	●		●		
3	General Purpose Flexible Polyolefin (2040)		●				
5	Viton Fluoroelastomer Blend (2050)	●		●	●		
6	High Performance Elastomer Alloy (2051)	●		●			
7	Semi-Rigid Polyolefin (2071)	●	●				
8	Low Outgassing Fluoropolymer Alloy (2008)	Material Type 8 not available with pre-coat adhesive. Use Type U two-part epoxy					
9	Low Temp Flexible Polyolefin (2013)		●				

NOTES

1. See **Modification Codes** listed in Section A for material color options available for **Type 1 (compound 2025)** material.
2. See **Reference Information** pages in this section for material and adhesive selection guides.
3. Recovered dimension apply to unrestricted recovery. Dimensions may differ than shown when boots are installed over assembly.



SERIES 77
Lipless Boots
770-005S Straight Boot
Dimensions



Lipless Straight Shrink Boots: Dimensions

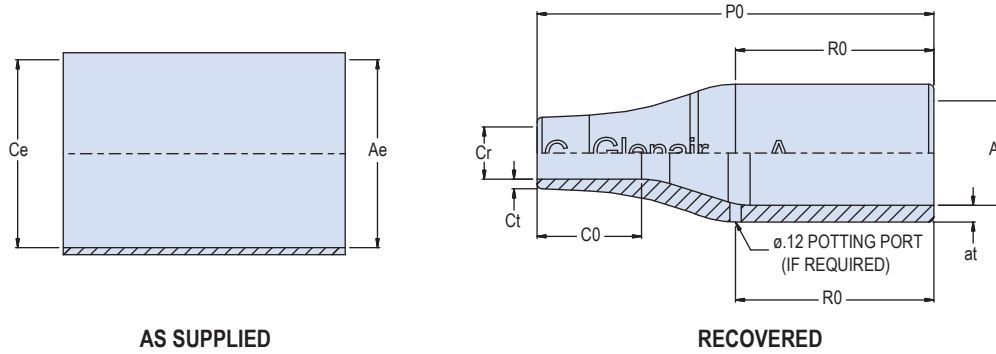

Dimensions											
Shell Size	Glenair Us Part Marking	Shell Size	Ae Dia Min	Ce Dia. Min	Ar Dia. max	at ±30%	Cr Dia. Max	ct ±20%	CO Ref	PO ±10%	RO Ref
00	S00	5	.354 (9.0)	.354 (9.0)	.217 (5.5)	.039 (1.0)	.079 (2.0)	.028 (0.7)	.295 (7.5)	.984 (25.0)	.551 (14.0)
01	S01	5,6	.472 (12.0)	.472 (12.0)	.276 (7.0)	.043 (1.1)	.118 (3.0)	.028 (0.7)	.295 (7.5)	.984 (25.0)	.551 (14.0)
02	S02	6,7	.669 (17.0)	.669 (17.0)	.276 (7.0)	.051 (1.3)	.138 (3.5)	.028 (0.7)	.394 (10.0)	1.181 (30.0)	.728 (18.5)
03	S03	8,10	.945 (24.0)	.945 (24.0)	.413 (10.5)	.063 (1.6)	.197 (5.0)	.035 (0.9)	.394 (10.0)	1.496 (38.0)	.748 (19.0)
04	S04	11-16	1.181 (30.0)	1.181 (30.0)	.551 (14.0)	.071 (1.8)	.236 (6.0)	.039 (1.0)	.630 (16.0)	2.165 (55.0)	1.181 (30.0)
05	S05	16-17	1.260 (32.0)	1.260 (32.0)	.709 (18.0)	.071 (1.8)	.276 (7.0)	.047 (1.2)	.748 (19.0)	2.638 (67.0)	1.299 (33.0)
06	S06	17-21	1.417 (36.0)	1.417 (36.0)	.866 (22.0)	.079 (2.0)	.335 (8.5)	.047 (1.2)	.787 (20.0)	3.150 (80.0)	1.575 (40.0)
07	S07	21-23	1.693 (43.0)	1.693 (43.0)	1.102 (28.0)	.087 (2.2)	.394 (10.0)	.051 (1.3)	1.142 (29.0)	3.898 (99.0)	2.165 (55.0)
08	S08	25	2.362 (60.0)	2.362 (60.0)	1.378 (35.0)	.130 (3.3)	.591 (15.0)	.063 (1.6)	1.575 (40.0)	5.118 (130.0)	1.969 (50.0)
09	S09		2.599 (66.0)	2.599 (66.0)	1.752 (44.5)	.150 (3.8)	.661 (16.8)	.079 (2.0)	2.283 (58.0)	6.693 (170.0)	3.543 (90.0)
10	S10		3.400 (86.4)	3.400 (86.4)	2.250 (57.2)	.160 (4.06)	1.06 (26.9)	.130 (3.3)	2.068 (52.5)	7.700 (195.6)	4.005 (102.0)

For materials Type 2, Type 3 and Type 9, dimension 'Ce' is nominal

Lipless Straight Boots: Part Marking, Raised Lettering

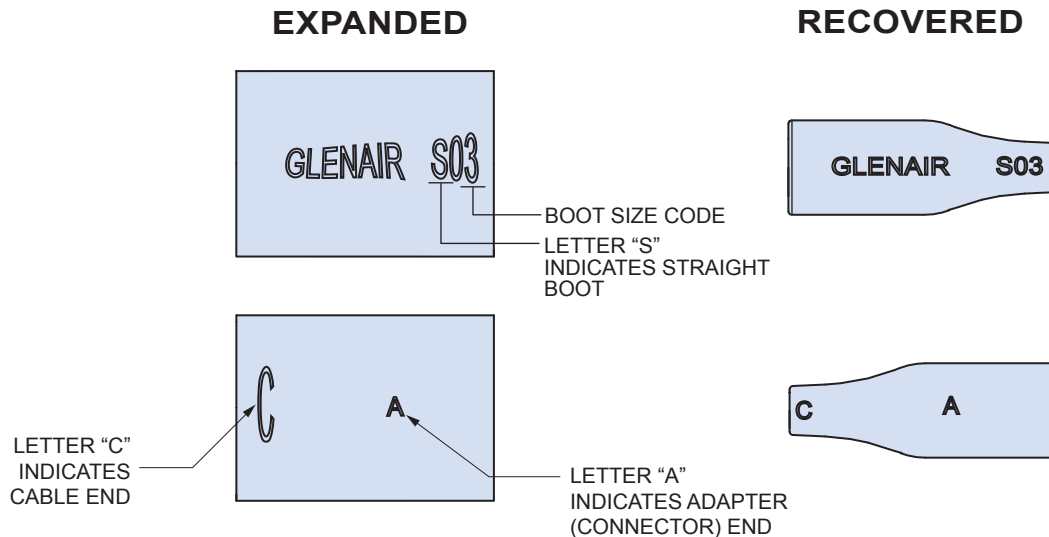



SERIES 77 Lipless Boots



770-019SB Shim Boot How to Order



Lipless, shim boots provide mechanical and environmental protection from damage and debris. Straight boots are available in eight material options with five adhesive choices. Glenair straight shim boots are made in accordance with AS85049 and fit most circular connectors. All adhesive lined and unlined shrink boots are RoHS compliant. Shim shrink boots are water-tight when equipped with factory installed or user-installed adhesive. Lipless boots bind to accessory threads at rear of connector without an additional adapter resulting in a lower profile and can be ordered with potting holes to fit your requirements. Choose boot size based on connector's rear thread diameter and cable diameter.

D

How to Order					
Sample Part Number		770	-019SB	6	03 W3
Product Series	770 = Series 77 shrink boot				
Basic Number	019SB = lipless shim boot without eyelet				
Material	See material and adhesives table				
Boot Size	01, 02, 03, 04 ; see shell size cross reference in dimensions table				
Adhesive Lined	Omit for none; see material and adhesives table				

Material and Adhesive Compatibility						
Material Code	Material Description (Compound No.)	Hot Melt Adhesives			High Performance Epoxy Adhesives	
		W1	W2	W3 (TACOM approved)	R	U
		High Temperature -55°C to 125°C	Standard -55°C to 70°C	Elastomeric -55°C to 125°C	Pre-Coat -75°C to 150°C	Two-Part -75°C to 155°C
1	High-Performance Semi-Rigid Elastomer (2025)	●	●		●	Type U epoxy adhesive is compatible with all boot materials. Ordered separately, user-installed (779-001). Order boot with no adhesive lining.
2	Zero Halogen Semi-Rigid Polyolefin (2010)	●	●		●	
3	General Purpose Flexible Polyolefin (2040)		●			
5	Viton Fluoroelastomer Blend (2050)	●		●	●	
6	High Performance Elastomer Alloy (2051)	●		●		
7	Semi-Rigid Polyolefin (2071)	●	●			
8	Low Outgassing Fluoropolymer Alloy (2008)	Material Type 8 not available with pre-coat adhesive. Use Type U two-part epoxy				
9	Low Temp Flexible Polyolefin (2013)		●			

NOTES

1. See **Modification Codes** listed in Section A for material color options available for **Type 1 (compound 2025)** material.
2. See **Reference Information** pages in this section for material and adhesive selection guides.
3. Recovered dimension apply to unrestricted recovery. Dimensions may differ than shown when boots are installed over assembly.



SERIES 77
Lipless Boots
770-019SB Shim Boot
Dimensions



Lipless Straight Shrink Boots: Dimensions

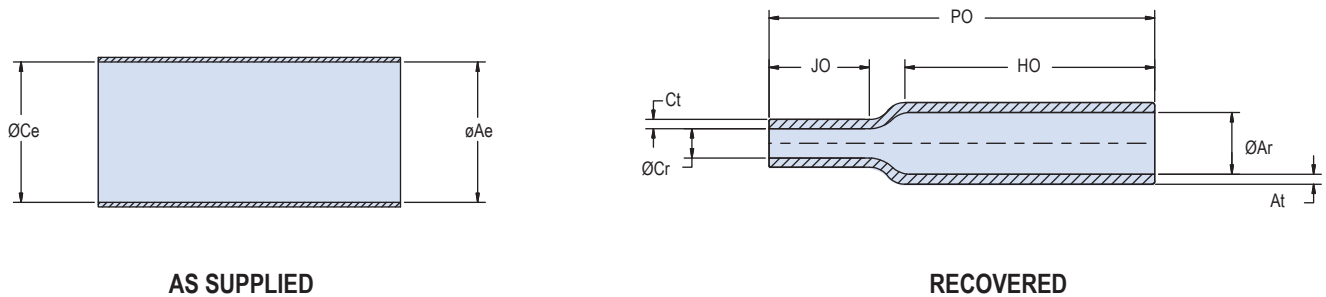

AS SUPPLIED

RECOVERED

Dimensions											
Boot Size	Glenair US Part Marking	Tacom Part No. (Ref)	Ae Min. Dia.	Ar Max. Dia.	At $\pm 10\%$	Ce Min. Dia.	Cr Max. Dia.	Ct $\pm 10\%$	PO $\pm 10\%$	HO $\pm 10\%$	JO $\pm 10\%$
01	SB1	12273164-1*	.500 (12.7)	.420 (10.7)	.060 (1.52)	.440 (11.2)	.110 (2.8)	.060 (1.52)	2.50 (63.5)	1.620 (41.1)	.620 (15.7)
02	SB2	12273164-3*	.820 (20.8)	.420 (10.7)	.060 (1.52)	.810 (20.6)	.210 (5.3)	.060 (1.52)	2.50 (63.5)	1.620 (41.1)	.650 (16.5)
03	SB3	12273164-2*	.870 (22.1)	.740 (18.8)	.090 (2.29)	.440 (11.2)	.100 (2.5)	.060 (1.52)	2.10 (53.3)	1.100 (27.9)	.620 (15.7)
04	SB4	12273164-4*	.870 (22.1)	.740 (18.8)	.090 (2.29)	.810 (20.6)	.310 (7.9)	.060 (1.52)	2.10 (53.3)	1.100 (27.9)	.650 (16.5)



For materials Type 2, Type 3 and Type 9, dimension 'Ce' is nominal

Lipless Straight Boots: Part Marking, Raised Lettering

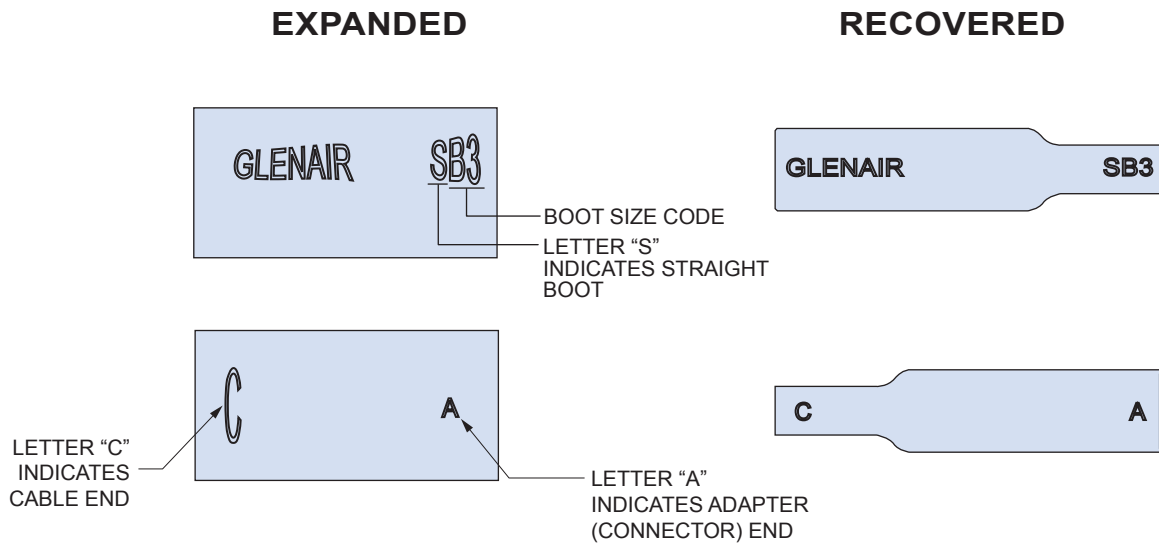



SERIES 77 Lipless Boots



770-027S Straight Shrink Boot How to Order

Lipless, straight shrink boots provide mechanical and environmental protection from damage and debris. Standard boots are available in eight material options with five adhesive choices. Glenair straight shrink boots are made in accordance with AS85045 and fit most circular connectors. All adhesive lined and unlined shrink boots are RoHS compliant. Shrink boots are water-tight when equipped with factory installed or user-installed adhesive. Lipless boots bind to accessory threads at rear of connector without an additional adapter resulting in a lower profile and can be ordered with potting holes to fit your requirements. Choose boot size based on connector's rear thread diameter and cable diameter.

D

How to Order							
Sample Part Number	770	-027	S	1	03	W1	-4
Product Series	770 = Series 77 shrink boot						
Basic Number	027 = lipless straight boot without eyelet						
Angular Function	S = straight						
Material	See material and adhesives table						
Boot Size	01, 02, 03, 04, 05, 06, 07, 08, 09, 10, 11; see shell size cross reference in dimensions table						
Adhesive Lined	Omit for none; see material and adhesives table						
Length	Length measured in 1/2 increments (eg. 4 = 2.0 inches), 1 inch minimum length						

Material and Adhesive Compatibility							
Material Code	Material Description (Compound No.)	Hot Melt Adhesives			High Performance Epoxy Adhesives		
		W1	W2	W3 (TACOM approved)	R	U	
		High Temperature -55°C to 125°C	Standard -55°C to 70°C	Elastomeric -55°C to 125°C	Pre-Coat -75°C to 150°C	Two-Part -75°C to 155°C	
1	High-Performance Semi-Rigid Elastomer (2025)	●	●		●	Type U epoxy adhesive is compatible with all boot materials. Ordered separately, user-installed (779-001). Order boot with no adhesive lining.	
2	Zero Halogen Semi-Rigid Polyolefin (2010)	●	●		●		
3	General Purpose Flexible Polyolefin (2040)		●				
5	Viton Fluoroelastomer Blend (2050)	●		●	●		
6	High Performance Elastomer Alloy (2051)	●		●			
7	Semi-Rigid Polyolefin (2071)	●	●				
8	Low Outgassing Fluoropolymer Alloy (2008)	Material Type 8 not available with pre-coat adhesive. Use Type U two-part epoxy					
9	Low Temp Flexible Polyolefin (2013)		●				

NOTES

1. See **Modification Codes** listed in Section A for material color options available for **Type 1 (compound 2025)** material.
2. See **Reference Information** pages in this section for material and adhesive selection guides.
3. Recovered dimension apply to unrestricted recovery. Dimensions may differ than shown when boots are installed over assembly.



SERIES 77
Lipless Boots



770-027 Straight Shrink Boot
Dimensions

Lipless Straight Shrink Boots: Dimensions

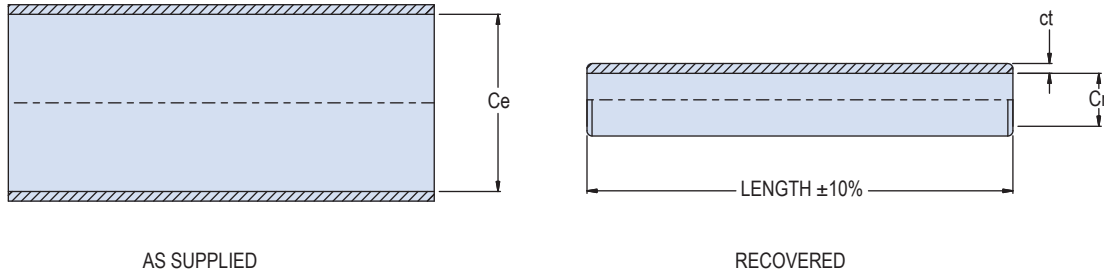

AS SUPPLIED

RECOVERED

Dimensions					
Boot Size	Glenair Part Marking	Ce Dia Min	Cr Dia Max	ct ±20%	Max Length*
01	S01	.620 (15.7)	.125 (3.2)	.043 (1.1)	3.00 (76.2)
02	S02	.886 (22.5)	.256 (6.5)	.047 (1.2)	3.50 (88.9)
03	S03	.984 (25.0)	.295 (7.5)	.047 (1.2)	3.50 (88.9)
04	S04	1.181 (30.0)	.335 (8.5)	.047 (1.2)	4.00 (102)
05	S05	1.378 (35.0)	.374 (9.5)	.047 (1.2)	5.00 (127)
06	S06	1.476 (37.5)	.413 (10.5)	.047 (1.2)	5.50 (140)
07	S07	1.772 (45.0)	.472 (12.0)	.047 (1.2)	6.00 (152)
08	S08	1.969 (50.0)	.551 (14.0)	.059 (1.5)	6.00 (152)
09	S09	2.469 (62.7)	.690 (17.5)	.059 (1.5)	6.00 (152)
10	S10	2.728 (69.3)	.770 (19.6)	.059 (1.5)	5.50 (140)
11	S11	3.220 (81.8)	.900 (22.9)	.059 (1.5)	5.50 (140)

*Consult factory for optional lengths

For materials Type 2, Type 3 and Type 9, dimension 'Ce' is nominal

Lipless Straight Boots: Part Marking, Raised Lettering

EXPANDED



RECOVERED

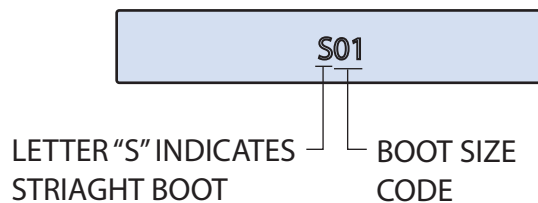



SERIES 77 Lipless Boots



770-005A Right Angle Boot How to Order



Lipless, 90° shrink boots provide mechanical and environmental protection from damage and debris. Boots are available in eight material options with five adhesive choices. Glenair 90° boots are made in accordance with AS85049 and fit most circular connectors. All adhesive lined and unlined shrink boots are RoHS compliant. Shrink boots are water-tight when equipped with factory installed or user-installed adhesive. Lipless boots bind to accessory threads at rear of connector without an additional adapter resulting in a lower profile and can be ordered with potting holes to fit your requirements. Choose boot size based on rear connector thread diameter and cable diameter.

D

How to Order	
Sample Part Number	770 -005 A 1 03 W1 -PP
Product Series	770 = Series 77 shrink boot
Basic Number	005 = lipless boot without eyelet
Angular Function	A = 90°
Material	See material and adhesives table
Boot Size	00, 02, 03, 04, 05, 06, 07, 08 ; see shell size cross reference in dimensions table
Adhesive Lined	Omit for none; see material and adhesives table
Potting Ports	PP = potting port Omit for none

Material Code		Material and Adhesive Compatibility				
		Hot Melt Adhesives			High Performance Epoxy Adhesives	
		W1	W2	W3 (TACOM approved)	R	U
Material Description (Compound No.)	High Temperature -55°C to 125°C	Standard -55°C to 70°C	Elastomeric -55°C to 125°C	Pre-Coat -75°C to 150°C	Two-Part -75°C to 155°C	
1 High-Performance Semi-Rigid Elastomer (2025)	●	●		●	Type U epoxy adhesive is compatible with all boot materials. Ordered separately, user-installed (779-001). Order boot with no adhesive lining.	
2 Zero Halogen Semi-Rigid Polyolefin (2010)	●	●		●		
3 General Purpose Flexible Polyolefin (2040)		●				
5 Viton Fluoroelastomer Blend (2050)	●		●	●		
6 High Performance Elastomer Alloy (2051)	●		●			
7 Semi-Rigid Polyolefin (2071)	●	●				
8 Low Outgassing Fluoropolymer Alloy (2008)	Material Type 8 not available with pre-coat adhesive. Use Type U two-part epoxy					
9 Low Temp Flexible Polyolefin (2013)		●				

NOTES

1. See **Modification Codes** listed in Section A for material color options available for **Type 1 (compound 2025)** material.
2. See **Reference Information** pages in this section for material and adhesive selection guides.
3. Recovered dimension apply to unrestricted recovery. Dimensions may differ than shown when boots are installed over assembly.



SERIES 77 Lipless Boots



770-005A Right Angle Boot Dimensions

Lipless Straight Shrink Boots: Dimensions

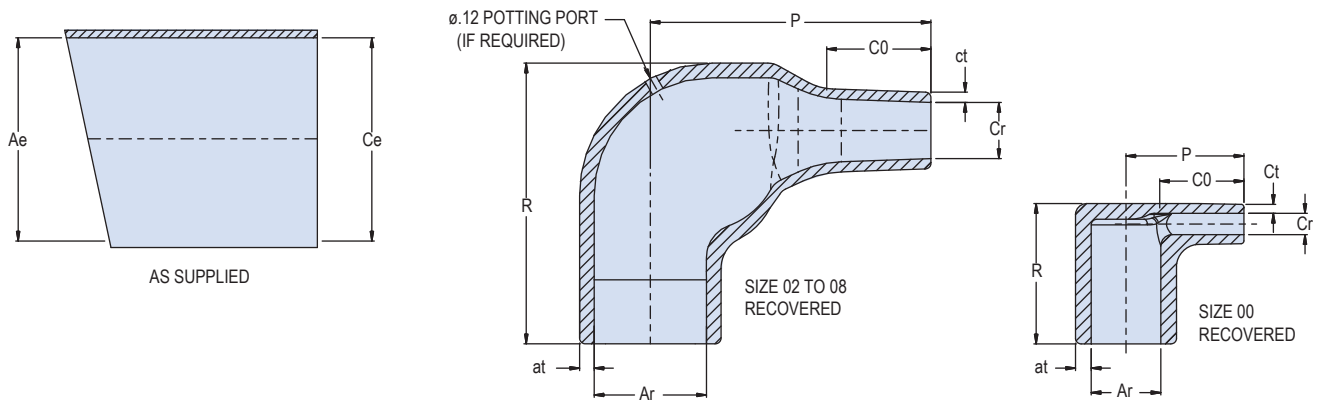

Dimensions											
Boot Size	Glenair US Part Marking	Shell Size	Ae Dia Min	Ce Dia Min	Ar Dia Max	at ±30%	Cr Dia Max	ct ±20%	CO Ref	P ±20%	R Ref
00	A00	5	.354 (9.0)	.354 (9.0)	.236 (6.0)	.039 (1.0)	.079 (2.0)	.028 (0.7)	.236 (6.0)	.413 (10.5)	.492 (12.5)
02	A02	7	.669 (17.0)	.669 (17.0)	.315 (8.0)	.051 (1.3)	.138 (3.5)	.028 (0.7)	.276 (7.0)	.787 (20.0)	.787 (20.0)
03	A03	9	.945 (24.0)	.945 (24.0)	.394 (10.0)	.063 (1.6)	.197 (5.0)	.035 (0.9)	.394 (10.0)	.984 (25.0)	.984 (25.0)
04	A04	11-15	1.181 (30.0)	1.181 (30.0)	.532 (13.5)	.071 (1.8)	.217 (5.5)	.039 (1.0)	.472 (12.0)	1.260 (32.0)	1.063 (27.0)
05	A05	13-17	1.260 (32.0)	1.260 (32.0)	.709 (18.0)	.071 (1.8)	.276 (7.0)	.047 (1.2)	.591 (15.0)	1.535 (39.0)	1.260 (32.0)
06	A06	17-21	1.417 (36.0)	1.417 (36.0)	.886 (22.5)	.079 (2.0)	.335 (8.5)	.047 (1.2)	.630 (16.0)	1.929 (49.0)	1.496 (38.0)
07	A07	21-23	1.693 (43.0)	1.693 (43.0)	1.102 (28.0)	.087 (2.2)	.394 (10.0)	.059 (1.5)	.709 (18.0)	2.165 (55.0)	1.850 (47.0)
08	A08	23-25	2.165 (55.0)	2.165 (55.0)	1.378 (35.0)	.130 (3.3)	.591 (15.0)	.079 (2.0)	1.260 (32.0)	3.150 (80.0)	2.165 (55.0)

For materials Type 2, Type 3 and Type 9, dimension 'Ce' is nominal

Lipless Straight Boots: Part Marking, Raised Lettering

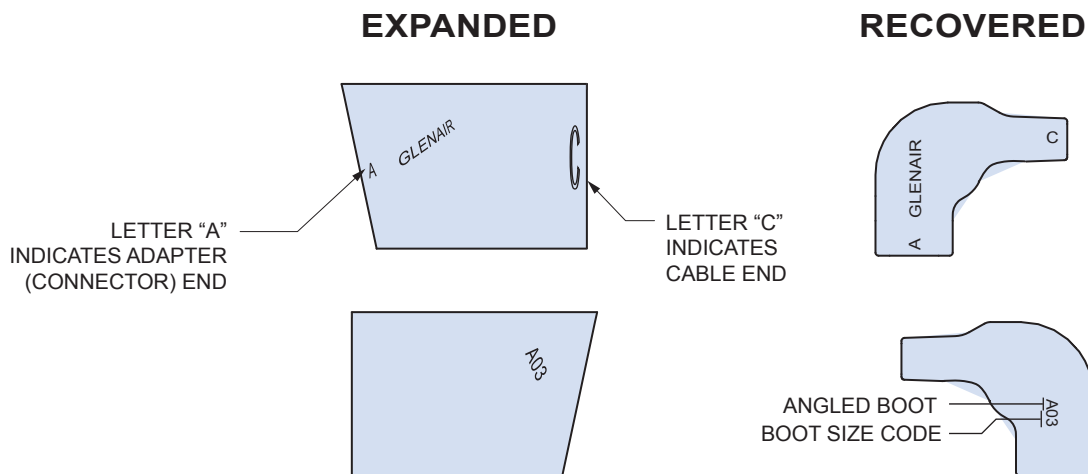

SERIES 77
HEAT SHRINK
BOOTS

SERIES SPECIFIC SHRINK BOOTS

For Mighty Mouse, HiPer-D[®],
Nanominiature, SuperSeal[™] and Superfly[®]



Glenair shrink boots extend our commitment to our customers by providing shrink boots specifically designed to fit our growing family of innovative high performance connectors. A snug fit is an essential characteristic of a well performing boot so trust that Glenair has taken the time to ensure a quality fit that will stand up to the wear and tear encountered in mil aero and space applications. All Glenair series specific shrink boots can be ordered with potting ports in your choice of 8 material options and 5 adhesives or none at all.



Glenair[®]

Glenair, Inc.
1211 Air Way
Glendale, CA 91201-2497
818-247-6000
sales@glenair.com
www.glenair.com

SERIES 77

Series Specific Heat Shrink Boots

Product Selection Guide

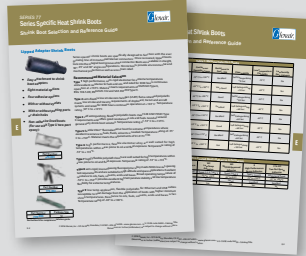

Series Specific Boot Selection and Reference GuideE-2



Series 23 SuperSeal™E-4



Series 89 NanominatureE-6



Series 28 HiPer-D®E-8



Series 88 Superfly®E-10



Series 80 Mighty MouseE-14



Shrink Boot Selection and Reference Guide

Lipped Adapter Shrink Boots



- *Easy attachment to shrink boot adapters*
- *Eight material options*
- *Four adhesive options*
- *With or without eyelets*
- *With or without potting ports or drain holes*
- *Non-adhesive lined boots (For use with Type U two-part epoxy):*

Series specific shrink boots are specifically designed to function with the ever growing line of miniaturized Glenair connectors. Once recovered, lipped boots lock into the integral boot groove of the connector. Boots are available in straight, 90°, 45° and 30° angle configurations. Shrink boots provide environmental and mechanical protection as well as wire strain relief.

Recommended Material Selection

Type 1 high performance, semi-rigid elastomer for extreme temperatures and excellent resistance to fuels and oils and rated for 3000 hours continuous operation at +150°C. Material meets requirements of VG95343 Type 6, BSG 198-5-DE, EN62329-102 and SAE AS5258 Type H.

Type 2 semi-flexible low smoke zero halogen (LSZH) flame-retarded polyolefin meets low smoke and toxicity requirements of shipboard, transit and aircraft systems and rated for 3000 hours continuous operation at +130° C. Temperature rating -40° C to +130°C

Type 3 self extinguishing, flexible polyolefin boots meet SAE AS8176581 Type II requirements and offers good resistance to oils and fuels. Good all around general duty shrink boot solution. Temperature rating of -55° C to +135°C.

Type 5 flexible Viton® fluoroelastomer boot for extreme temperatures where excellent resistance to fuels, fluids, solvents is needed. Temperature rating of -55° C to +150°C. Material meets the requirements of SC-X15111D.

Type 6 high performance, flexible elastomer alloy are well suited for high temperatures within areas prone to oil and fluid exposure. Temperature rating of -55° to +135°C.

Type 7 highly flexible polyolefin boots are well suited for high temperatures within areas prone to oil and fluid exposure. Temperature rating of -55° to +135°C.

Type 8 semi-rigid, low outgassing fluoropolymer alloy meets NASA low out-gassing test requirements and are suitable for high altitude and space applications. Excellent resistance to oils, fuels, solvents, acids and bases. Broad operating temperature of -50° C to +150° C provides excellent high temperature stability and low temperature flexibility for extreme temperatures.

Type 9 low temp application, flexible polyolefin for Ethernet and USB cables susceptible to heat damage from the application of boots with higher minimum shrink temperatures. Resistance to oils, fuels, solvents, acids and bases is fair. Temperature rating of -40° to +100°C.



Part Number
779-001



Part Number
779-002



Part Number	Package Size
779-003	12

See Section G for complete installation guide



Shrink Boot Selection and Reference Guide

Table 1: Material Selection Guide						
Material Type	Flexibility	Continuous Operating Temp.	Resistance to Fuels, Oils	Flammability	Low Temperature Flexibility	Low Toxicity, Zero Halogen
Type 1 High-Performance Semi-Rigid Elastomer	Semi-rigid	-75° C to +150° C	Excellent	Self-Extinguishing <15 Sec	-75° C	No
Type 2 Zero Halogen Semi-Rigid Polyolefin	Semi-flexible	-40° C to +130° C	Very Good	Self-Extinguishing <15 Sec	-40° C	Yes
Type 3 General Purpose Flexible Polyolefin	Flexible	-55° C to +135° C	Good	Self-Extinguishing <120 Sec	-55° C	No
Type 5 Viton Fluoroelastomer Blend	Flexible	-55° C to +150° C	Excellent	Self-Extinguishing <60 Sec	-55° C	No
Type 6 High Performance Elastomer Alloy	Flexible	-55° C to +135° C	Excellent	Self-Extinguishing <60 Sec	-55° C	No
Type 7 Semi-Rigid Polyolefin	Highly Flexible	-55° C to +135° C	Good	Self-Extinguishing <60 Sec	-55° C	No
Type 8 Low Outgassing Fluoropolymer Alloy	Semi-Rigid	-50° C to +175° C	Excellent	Self-Extinguishing <60 Sec	-50° C	No
Type 9 Low Temp Flexible Polyolefin	Flexible	-40° C to +100° C	Fair	Self-Extinguishing <120 Sec	-40° C	No

E

Table 2: Pre-Coated Boots Adhesive Information					
Attribute	W1 High Performance Adhesive	W2 Low Temp Adhesive	W3 TACOM Approved Adhesive	R High Performance Epoxy Adhesive	779-001 Two Part Epoxy Adhesive
Boot Material Compatibility	Types 1, 2, 5, 6 and 7	Types 1, 2, 3, 7 and 9	Types 5 and 6	Type 1, 2 and 5	All Material Types
Continuous Operating Temp.	-55° to +125°C	-55° to +70°C	-55° to +125°C	-75° to +150°C	-75° to +150°C
Resistance to Fuels, Oils, and Fluids	Good	Good	Good	Excellent	Excellent
Low Toxicity, Zero Halogen	Yes	Yes	No	Yes	Yes

Series Specific Heat Shrink Boots



770-028S SuperSeal 38999 Type RJ45 Straight Boot How to Order



Straight shrink boots provide mechanical and environmental protection from damage and debris. Boots are only available in low temp compound 2013 material. Straight boots are made in accordance with AS85049 and fit most 38999 standard boot adapters. Available with or without pre-applied low temp hot melt adhesive (W2). Shrink boots are RoHS compliant and water-tight when equipped with factory installed or user-installed adhesive. Lipped boots lock into boot groove located on adapter, while lipless boots shrink tightly around accessory threads on connector. Choose boot size based on adapter or connector accessory thread diameter and cable diameter.

How to Order						
Sample Part Number	770	-028	S	9	06	U
Product Series	770 = Series 77 shrink boot					
Basic Number	028 = lipped boot					
Angular Function	S = straight					
Material	9 = Type 9 material (2013)					
Boot Size	04, 06; see boot size to shell size cross reference in dimensions table					
Adhesive	U = no adhesive Omit = standard adhesive (W2)					

Material		
Material Type Code	Compound	Material Description
9	2013	Low temp flexible polyolefin

Adhesive	
Code	Description
Omit	-55°C to +70°C low temperature (W2)
U	No adhesive

E

770-028S SuperSeal 38999 Type RJ45 Straight Boot Dimensions

Lipped Straight Adapter Shrink Boots, Standard: Dimensions

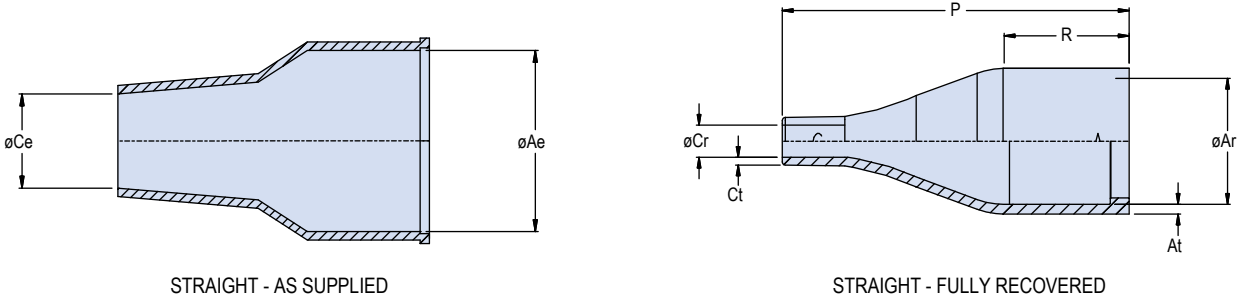

Dimensions										
Boot Size	Glenair Us Part Marking	Shell Size RJ45 Coupler D38999 Series III	Ae Min Dia	Ar Max Dia	At ±10%	Ce Min Dia	Cr Max Dia	Ct ±10%	P ±10%	R ±10%
04	S04	15 (Lipless)	1.20 (30.5)	.850 (21.6)	.070 (1.78)	.700 (17.8)	.240 (6.10)	.040 (1.00)	2.167 (55.0)	1.18 (30.0)
06	R06	17,19	1.20 (30.5)	.850 (21.6)	.065 (1.65)	.700 (17.8)	.210 (5.33)	.047 (1.19)	2.167 (55.0)	.787 (20.0)

Dimension 'Ce' is nominal

Lipped Straight Shrink Boots: Part Marking, Raised Lettering

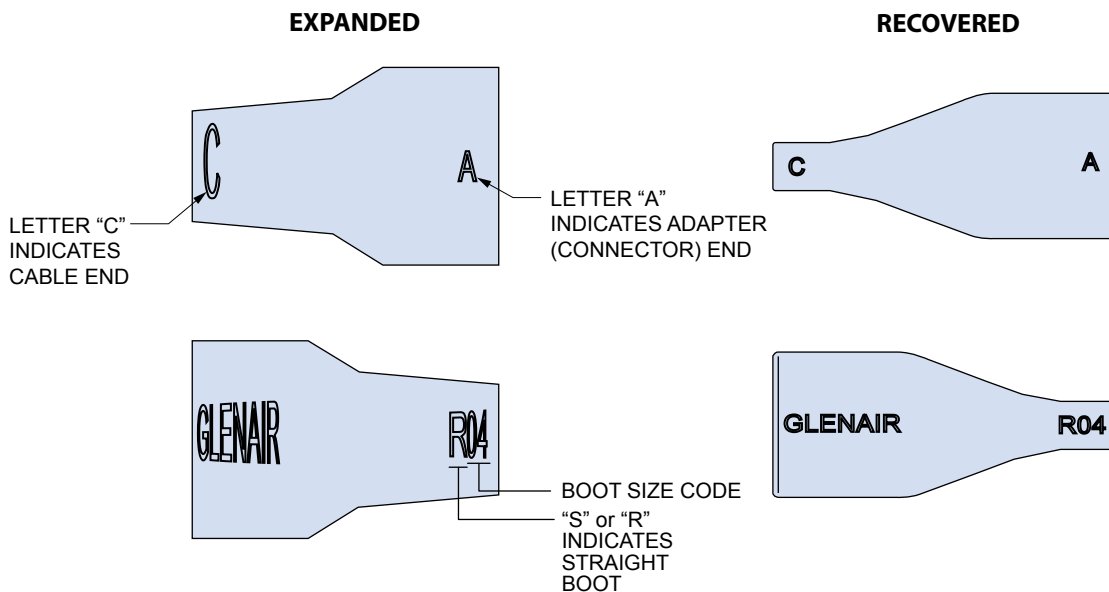

770-029S Series 89 Nanominiature Straight Boot How to Order



Series 89 Nanominiature straight shrink boots provide mechanical and environmental protection from damage and debris. Standard boots are available in eight material options with five adhesive choices. Straight boots are made specifically for the series 89 nano-circular connector series. All adhesive lined and unlined shrink boots are RoHS compliant. Shrink boots are water-tight when equipped with factory installed or user-installed adhesive. Lipped boots lock into boot groove located on adapter. Choose boot size based on adapter or connector accessory thread diameter and cable diameter.

How to Order						
Sample Part Number		770	-029	S	1	01 W1
Product Series	770 = Series 77 shrink boot					
Basic Number	029 = lipped boot					
Angular Function	S = straight					
Material	See material and adhesives table					
Boot Size	01, 02; see boot to shell size cross reference in dimensions table					
Adhesive	See adhesive table					

Material and Adhesive Compatibility							
Material Code	Material Description (Compound No.)	Hot Melt Adhesives			High Performance Epoxy Adhesives		
		W1	W2	W3 (TACOM approved)	R	U	
		High Temperature -55°C to 125°C	Standard -55°C to 70°C	Elastomeric -55°C to 125°C	Pre-Coat -75°C to 150°C	Two-Part -75°C to 155°C	
1	High-Performance Semi-Rigid Elastomer (2025)	●	●		●	Type U epoxy adhesive is compatible with all boot materials. Ordered separately, user-installed (779-001). Order boot with no adhesive lining.	
2	Zero Halogen Semi-Rigid Polyolefin (2010)	●	●		●		
3	General Purpose Flexible Polyolefin (2040)		●				
5	Viton Fluoroelastomer Blend (2050)	●		●	●		
6	High Performance Elastomer Alloy (2051)	●		●			
7	Semi-Rigid Polyolefin (2071)	●	●				
8	Low Outgassing Fluoropolymer Alloy (2008)	Material Type 8 not available with pre-coat adhesive. Use Type U two-part epoxy					
9	Low Temp Flexible Polyolefin (2013)		●				

NOTES

1. See **Modification Codes** listed in Section A for material color options available for **Type 1 (compound 2025)** material.
2. See **Reference Information** pages in this section for material and adhesive selection guides.
3. Recovered dimension apply to unrestricted recovery. Dimensions may differ than shown when boots are installed over assembly.

770-029S Series 89 Nanominiature Straight Boot Dimensions

Lipped Straight Adapter Shrink Boots, Standard: Dimensions

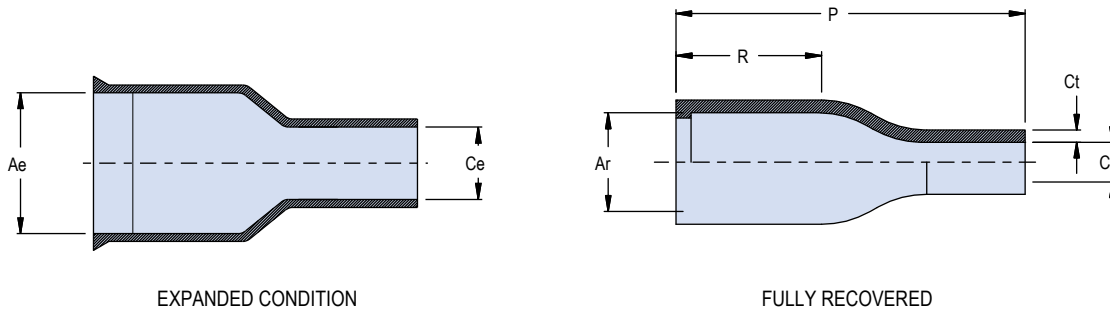

Dimensions											
Boot Size	Glenair Part Marking	Shell Size	Ae Min Dia	Ce Min Dia	Ar Max Dia	Cr Max Dia	P Ref	Ct Ref	R Ref	Cable Range	
										Max	Min
01	NS1	1	0.370 (9.40)	.110 (2.79)	.14 (3.56)	.055 (1.40)	.70 (17.78)	.030 (.76)	.33 (8.38)	.10 (1.40)	.055 (1.40)
02	NS2	2, 3, 4	0.550 (13.97)	.370 (9.40)	.20 (5.08)	.095 (2.41)	.75 (19.05)	.030 (.76)	.33 (8.38)	.30 (2.79)	.110 (2.79)

For materials Type 2, Type 3 and Type 9, dimension 'Ce' is nominal

Lipped Straight Shrink Boots: Part Marking, Raised Lettering

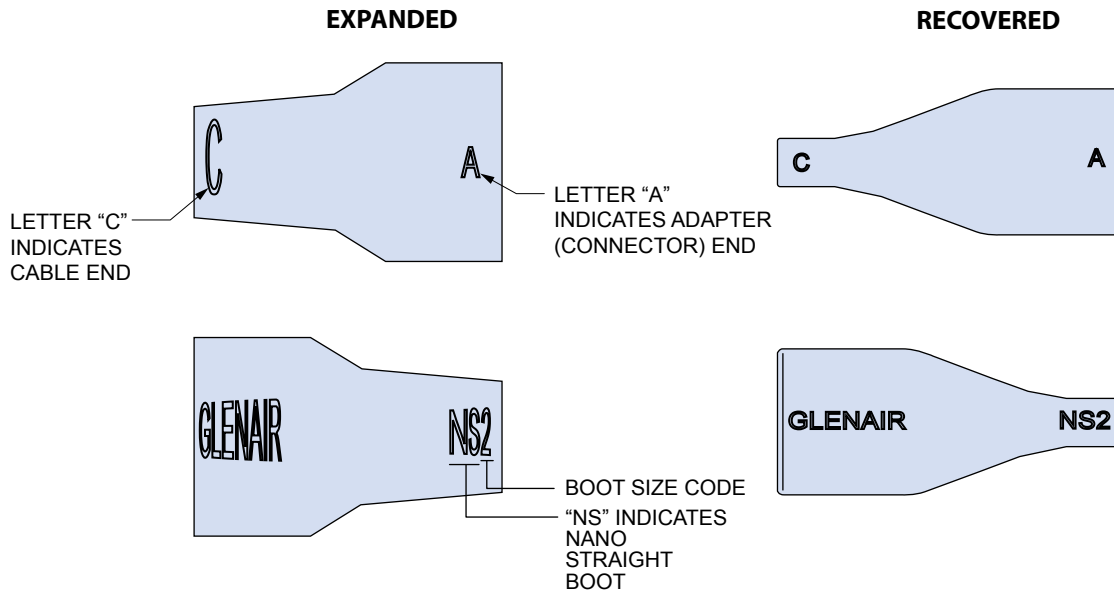

SERIES 77 Series Specific Heat Shrink Boots



770-030 Series 28 HiPer-D Elliptical Boot How to Order



Series 28 HiPer-D® elliptical straight shrink boots provide mechanical and environmental protection from damage and debris. Boots are available in eight material options with five adhesive choices. Boots are made to fit Glenair Series 28 HiPer-D. All adhesive lined and unlined shrink boots are RoHS compliant. Shrink boots are water-tight when equipped with factory installed or user-installed adhesive. Lipped boots lock into boot groove located on adapter. Choose boot size based on adapter or connector accessory thread diameter and cable diameter.

How to Order

Sample Part Number	770	-030	3	05	W1
Product Series	770 = Series 77 shrink boot				
Basic Number	030 = lipped boot				
Material	See material and adhesives table				
Boot Size	See dimensions table				
Adhesive	See material and adhesives table				

E

Material and Adhesive Compatibility

Material Code	Material Description (Compound No.)	Hot Melt Adhesives			High Performance Epoxy Adhesives	
		W1	W2	W3 (TACOM approved)	R	U
		High Temperature -55°C to 125°C	Standard -55°C to 70°C	Elastomeric -55°C to 125°C	Pre-Coat -75°C to 150°C	Two-Part -75°C to 155°C
1	High-Performance Semi-Rigid Elastomer (2025)	●	●		●	Type U epoxy adhesive is compatible with all boot materials. Ordered separately, user-installed (779-001). Order boot with no adhesive lining.
2	Zero Halogen Semi-Rigid Polyolefin (2010)	●	●		●	
3	General Purpose Flexible Polyolefin (2040)		●			
5	Viton Fluoroelastomer Blend (2050)	●		●	●	
6	High Performance Elastomer Alloy (2051)	●		●		
7	Semi-Rigid Polyolefin (2071)	●	●			
8	Low Outgassing Fluoropolymer Alloy (2008)	Material Type 8 not available with pre-coat adhesive. Use Type U two-part epoxy				
9	Low Temp Flexible Polyolefin (2013)		●			

NOTES

1. See **Modification Codes** listed in Section A for material color options available for **Type 1 (compound 2025)** material.
2. See **Reference Information** pages in this section for material and adhesive selection guides.
3. Recovered dimension apply to unrestricted recovery. Dimensions may differ than shown when boots are installed over assembly.

770-030 Series 28 HiPer-D Elliptical Boot Dimensions

Lipped Straight Adapter Shrink Boots, Standard: Dimensions

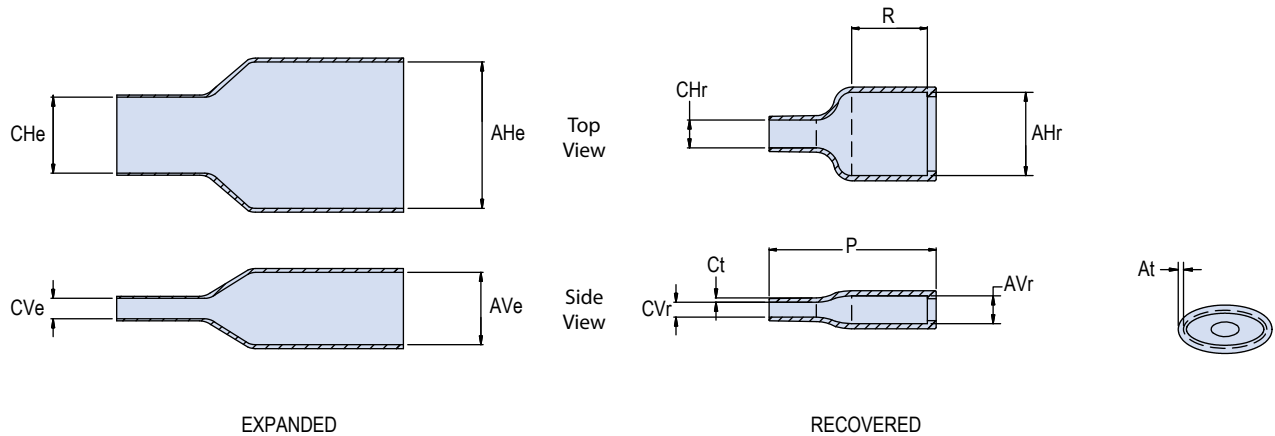

Dimensions													
Boot Size	Glenair Part Marking	AHe Min	AVe Min	CHe Min	CVe Min	AHr Max	AVr Max	At ±10%	CHr Max	CVr Max	Ct ±10%	P ±10%	R ±10%
05	E05	2.00 (50.8)	1.00 (25.4)	1.50 (38.1)	.800 (20.3)	1.125 (28.6)	.375 (9.53)	.070 (1.78)	.375 (9.53)	.200 (5.08)	.060 (1.52)	2.29 (58.2)	1.062 (27)
06	E06	2.50 (63.5)	1.50 (38.1)	1.80 (45.7)	.580 (14.7)	1.637 (41.6)	.375 (9.53)	.070 (1.78)	.450 (11.43)	.145 (3.68)	.060 (1.52)	3.05 (77.5)	1.062 (27)

For materials Type 2, Type 3 and Type 9, dimension 'CHe' is nominal

Lipped Straight Shrink Boots: Part Marking, Raised Lettering

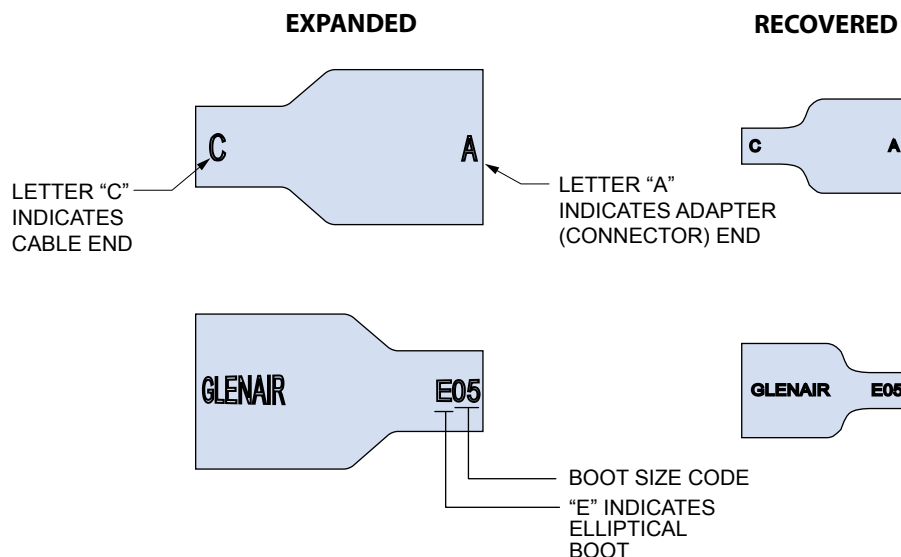

770-031S Series 88 SuperFly® Straight Boot How to Order



Series 88 SuperFly® straight shrink boots provide mechanical and environmental protection from damage and debris. Boots are available in eight material options with five adhesive choices. Boots are made to fit Glenair Series 88 SuperFly connectors. All adhesive lined and unlined shrink boots are RoHS compliant. Shrink boots are water-tight when equipped with factory installed or user-installed adhesive. Lipped boots lock into boot groove located on adapter or integral backshell of connector. Choose boot size based on adapter or connector accessory thread diameter and cable diameter.

How to Order						
Sample Part Number	770	-031	S	1	02	W1
Product Series	770 = Series 77 shrink boot					
Basic Number	031 = lipped boot					
Angular Function	S = straight					
Material	See material and adhesives table					
Boot Size	See dimensions table					
Adhesive	See material and adhesives table					

Material and Adhesive Compatibility							
Material Code	Material Description (Compound No.)	Hot Melt Adhesives			High Performance Epoxy Adhesives		
		W1	W2	W3 (TACOM approved)	R	U	
		High Temperature -55°C to 125°C	Standard -55°C to 70°C	Elastomeric -55°C to 125°C	Pre-Coat -75°C to 150°C	Two-Part -75°C to 155°C	
1	High-Performance Semi-Rigid Elastomer (2025)	●	●		●	Type U epoxy adhesive is compatible with all boot materials. Ordered separately, user-installed (779-001). Order boot with no adhesive lining.	
2	Zero Halogen Semi-Rigid Polyolefin (2010)	●	●		●		
3	General Purpose Flexible Polyolefin (2040)		●				
5	Viton Fluoroelastomer Blend (2050)	●		●	●		
6	High Performance Elastomer Alloy (2051)	●		●			
7	Semi-Rigid Polyolefin (2071)	●	●				
8	Low Outgassing Fluoropolymer Alloy (2008)	Material Type 8 not available with pre-coat adhesive. Use Type U two-part epoxy					
9	Low Temp Flexible Polyolefin (2013)		●				

NOTES

1. See **Modification Codes** listed in Section A for material color options available for **Type 1 (compound 2025)** material.
2. See **Reference Information** pages in this section for material and adhesive selection guides.
3. Recovered dimension apply to unrestricted recovery. Dimensions may differ than shown when boots are installed over assembly.

770-031S Series 88 SuperFly® Straight Boot Dimensions

Lipped Straight Adapter Shrink Boots, Standard: Dimensions

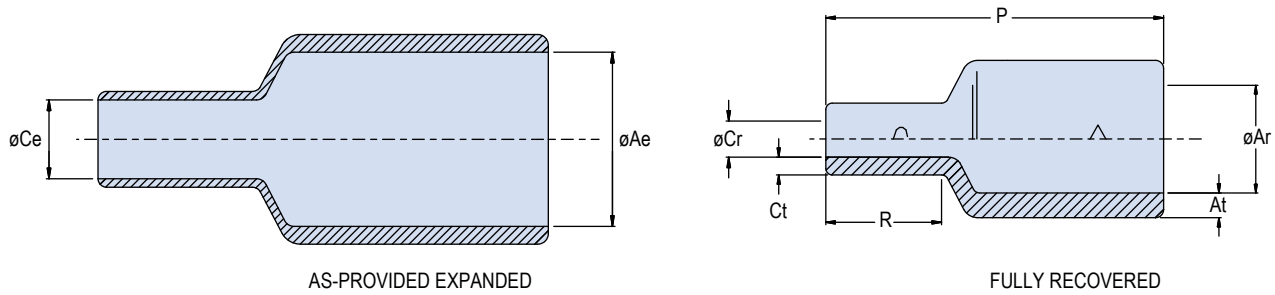

Dimensions									
Boot Size	Glenair Part Marking	Ae Min Dia	AR Max Dia	At ±10%	Ce Min Dia	Cr Max Dia	Ct ±10%	P ±10%	R ±10%
01	SF1	.37 (9.4)	.160 (4.06)	.040 (1.02)	.18 (4.57)	.045 (1.14)	.030 (.76)	.533 (13.5)	.183 (4.65)
02	SF2	.37 (9.4)	.200 (5.08)	.045 (1.14)	.18 (4.57)	.065 (1.65)	.031 (.79)	.568 (14.4)	.201 (5.11)
03	SF3	.56 (14.2)	.260 (6.60)	.050 (1.27)	.37 (9.40)	.100 (2.54)	.035 (.89)	.600 (15.2)	.205 (5.21)

For materials Type 2, Type 3 and Type 9, dimension 'Ce' is nominal

E

Lipped Straight Shrink Boots: Part Marking, Raised Lettering

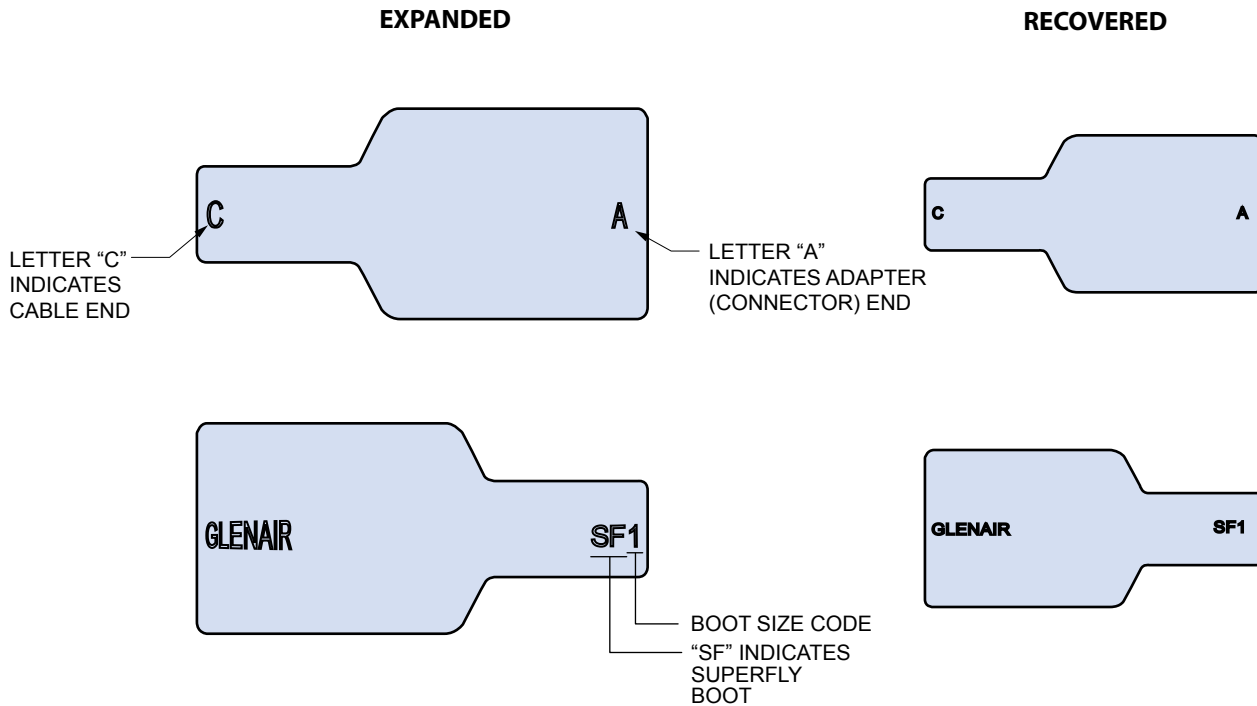

770-031A Series 88 SuperFly® 90° Shrink Boot How to Order



Series 88 SuperFly® 90° shrink boots provide mechanical and environmental protection from damage and debris. Boots are available in eight material options with five adhesive choices. Boots are made to fit Glenair Series 88 SuperFly® connectors. All adhesive lined and unlined shrink boots are RoHS compliant. Shrink boots are water-tight when equipped with factory installed or user-installed adhesives. Lipped boots lock into boot groove located on adapter or integrated connector backshell. Choose boot size based on adapter or connector accessory thread diameter and cable diameter.

How to Order						
Sample Part Number		770	-031	A	1	02 W1
Product Series	770 = Series 77 shrink boot					
Basic Number	031 = lipped boot					
Angular Function	A = 90° angle					
Material	See material and adhesives table					
Boot Size	See dimensions table					
Adhesive	See material and adhesives table					

E

Material and Adhesive Compatibility						
Material Code	Material Description (Compound No.)	Hot Melt Adhesives			High Performance Epoxy Adhesives	
		W1	W2	W3 (TACOM approved)	R	U
		High Temperature -55°C to 125°C	Standard -55°C to 70°C	Elastomeric -55°C to 125°C	Pre-Coat -75°C to 150°C	Two-Part -75°C to 155°C
1	High-Performance Semi-Rigid Elastomer (2025)	●	●		●	Type U epoxy adhesive is compatible with all boot materials. Ordered separately, user-installed (779-001). Order boot with no adhesive lining.
2	Zero Halogen Semi-Rigid Polyolefin (2010)	●	●		●	
3	General Purpose Flexible Polyolefin (2040)		●			
5	Viton Fluoroelastomer Blend (2050)	●		●	●	
6	High Performance Elastomer Alloy (2051)	●		●		
7	Semi-Rigid Polyolefin (2071)	●	●			
8	Low Outgassing Fluoropolymer Alloy (2008)	Material Type 8 not available with pre-coat adhesive. Use Type U two-part epoxy				
9	Low Temp Flexible Polyolefin (2013)		●			

NOTES

1. See **Modification Codes** listed in Section A for material color options available for **Type 1 (compound 2025)** material.
2. See **Reference Information** pages in this section for material and adhesive selection guides.
3. Recovered dimension apply to unrestricted recovery. Dimensions may differ than shown when boots are installed over assembly.

770-031A Series 88 SuperFly® 90° Shrink Boot Dimensions

Lipped Straight Adapter Shrink Boots, Standard: Dimensions

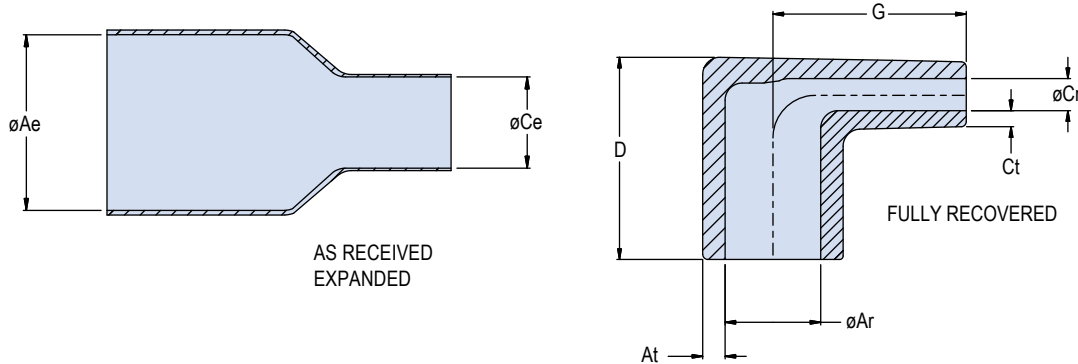

Dimensions									
Boot Size	Glenair Part Marking	Ae Min Dia	AR Max Dia	At $\pm 10\%$	Ce Min Dia	Cr Max Dia	Ct $\pm 10\%$	G $\pm 10\%$	D $\pm 10\%$
01	SF1A	.37 (9.4)	.160 (4.06)	.040 (1.02)	.18 (4.57)	.045 (1.14)	.030 (.76)	.300 (7.62)	.380 (9.65)
02	SF2A	.37 (9.4)	.200 (5.08)	.045 (1.14)	.18 (4.57)	.065 (1.65)	.031 (.79)	.375 (9.53)	.395 (10.0)
03	SF3A	.56 (14.2)	.260 (6.60)	.050 (1.27)	.37 (9.40)	.095 (2.41)	.035 (.89)	.440 (11.2)	.469 (11.9)

For materials Type 2, Type 3 and Type 9, dimension 'C' is nominal

Lipped Straight Shrink Boots: Part Marking, Raised Lettering

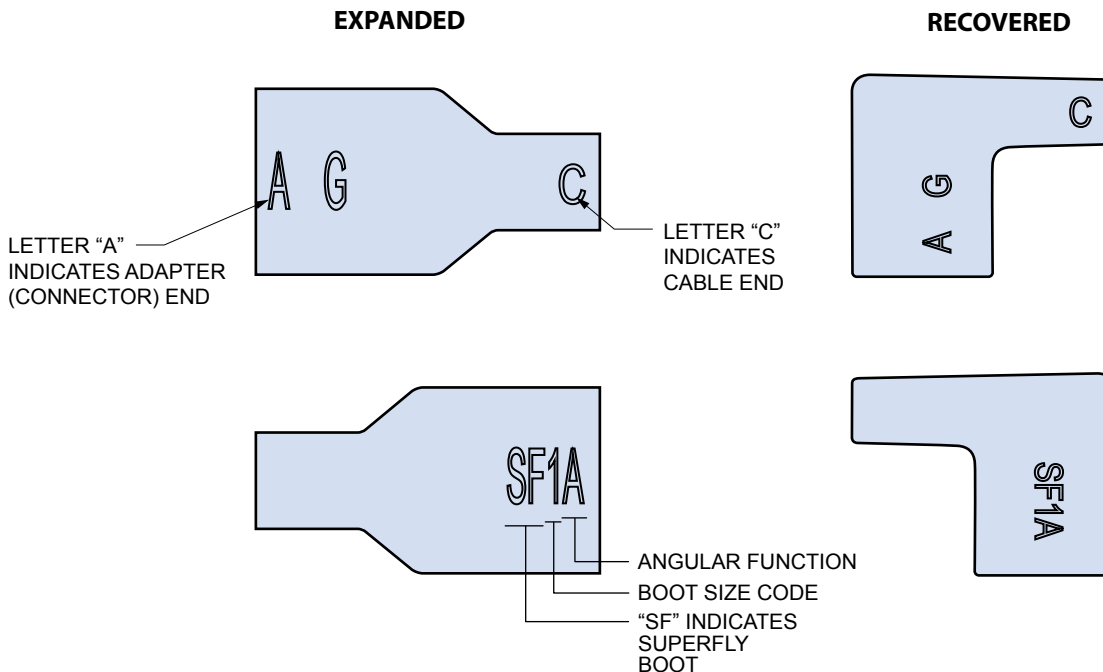

Series Specific Heat Shrink Boots



809S060 Series 80 Mighty Mouse and Series 806 Mil-Aero Straight Boot • How to Order



Series 80 Mighty Mouse straight shrink boots provide mechanical and environmental protection from damage and debris. Boots are available in four material options with matched adhesive. Boots are made to fit Glenair Series 80 Mighty Mouse connectors. All adhesive lined and unlined shrink boots are RoHS compliant. Shrink boots are water-tight when equipped with factory installed or user-installed adhesives. Lipped boots lock into boot groove located on adapter or integrated connector backshell. Choose boot size based on adapter or connector accessory thread diameter and cable diameter.

How to Order							
Sample Part Number	809	S	060	-4	H	U	-PP
Product Series	809 = Series 80 shrink boot						
Angular Function	S = straight						
Basic Number	060 = lipped boot						
Dash Number	1, 2, 3, 4, 5, 6; See dimensions table						
Material	Omit for type 1 H = type 2 L = type 9 S = type 8 see material and adhesive table						
Adhesive Options	Omit for recommended adhesive OR U = no adhesive R = epoxy pre-coat adhesive see material and adhesive table for availability						
Potting Port	PP = potting port Omit for none						

Material and Adhesive				
Material Code (Type)	Compound	Material Description	Recommended Adhesive	Adhesive Option
Omit (Type 1; Standard)	2025	Fluid Resistant Semi-Rigid Elastomer	W1: -55°C to +125°C pre-coat hot melt; high performance	R or U
H (Type 2)	2010	NAVSEA 5617649 ZH/LS Fire Hazard Material	W1: -55°C to +125° pre-coat hot melt; high performance	R or U
G (Type 3)	2040	General-Purpose Flexible Polyolefin	W2: -55°C to +70°C pre-coat hot melt; low temperature	U
V (Type 5)	2050	Viton Fluoroelastomer Blend	W1: -55°C to +125° pre-coat hot melt; high performance	R or U
E (Type 6)	2051	High-Performance Elastomer Polymer Alloy	W1: -55°C to +125° pre-coat hot melt; high performance	U
F (Type 7)	2071	Flexible Polyolefin	W2: -55°C to +70°C pre-coat hot melt; low temperature	U
S (Type 8)	2008	Low Outgassing Fluoropolymer	U: -75°C to +150°C two part epoxy 779-001 two part epoxy, sold separately	None
L (Type 9)	2013	Low Temp Flexible Polyolefin	W2: -55°C to +70°C pre-coat hot melt; low temperature	U
N (Type 11)	2011B	Radiation-Resistant Polyolefin	N/A	U

NOTES

1. See **Modification Codes** listed in Section A for material color options available for **Type 1 (compound 2025)** material.
2. See **Reference Information** pages in this section for material and adhesive selection guides
3. Recovered dimension apply to unrestricted recovery. Dimensions may differ than shown when boots are installed over assembly.

809S060 Series 80 Mighty Mouse and Series 806 Mil-Aero Straight Boot • Dimensions

Lipped Straight Adapter Shrink Boots: Dimensions

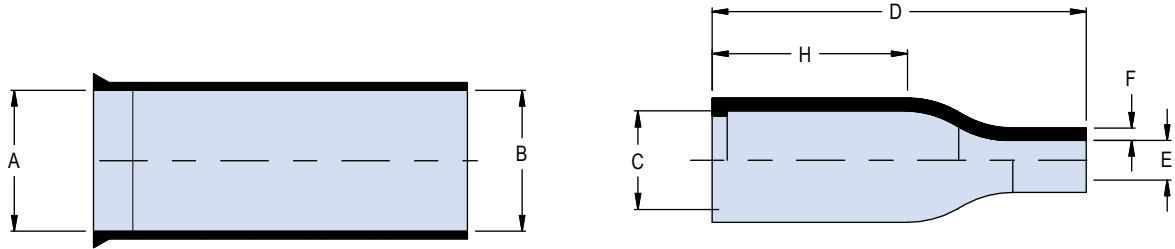

Dimensions												
Dash No.	Shell Size			A Min Dia	B Min Dia	C Max*	D Ref	E Max	F Ref	H Ref*	Cable Range	
	800, 801 802, 803 804	805	806								Max	Min
1	5/6	8	7/8	.390 (9.91)	.390 (9.91)	.26 (6.60)	1.37 (34.80)	.08 (2.03)	.030 (0.76)	.75 (19.05)	.23 (5.84)	.10 (2.54)
2	7	9	9	.669 (16.99)	.669 (16.99)	.30 (7.62)	1.50 (38.10)	.14 (3.56)	.032 (0.81)	.75 (19.05)	.50 (12.70)	.17 (4.32)
3	8/9	10/11	10/11	.945 (24.00)	.945 (24.00)	.39 (9.91)	1.50 (38.10)	.20 (5.08)	.035 (0.89)	.75 (19.05)	.80 (20.32)	.24 (6.10)
4	10/11 12/13	12/13/15	12/14/16	1.181 (30.00)	1.181 (30.00)	.55 (13.97)	2.17 (55.12)	.24 (6.10)	.039 (0.99)	1.18 (29.97)	1.02 (25.91)	.28 (7.11)
5	14/15 16/17	18/19	18	1.260 (32.00)	1.260 (32.00)	.71 (18.03)	2.64 (67.06)	.28 (7.11)	.039 (0.99)	1.30 (33.02)	1.12 (28.45)	.30 (7.62)
6	19/21	21/23	20/22/24	1.417 (35.99)	1.417 (35.99)	.90 (22.86)	3.15 (80.01)	.33 (8.38)	.047 (1.19)	1.57 (39.88)	1.20 (30.48)	.35 (8.89)

For materials Type 2 and Type 9, dimension 'B' is nominal

*Recovered boot dimensions accommodate a band and braid for shielded applications.

Lipped Straight Shrink Boots: Part Marking, Raised Lettering

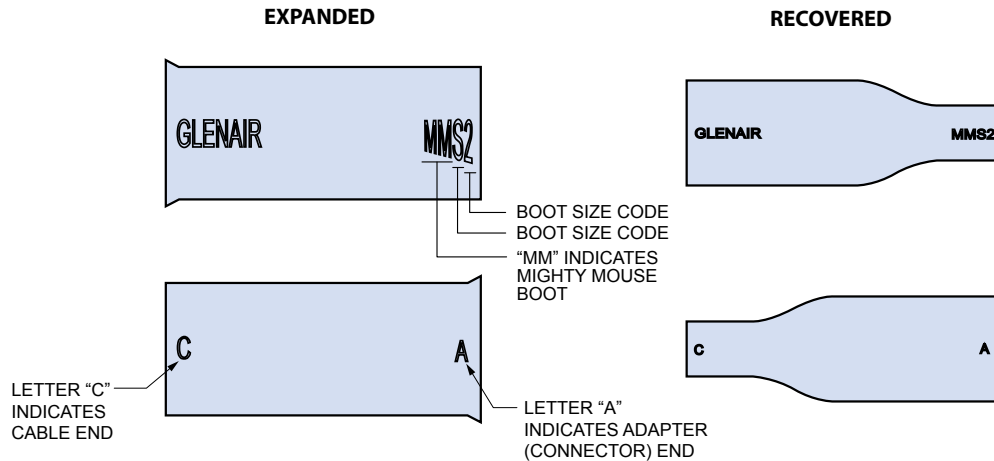

809A060 Series 80 Mighty Mouse and Series 806 Mil-Aero Right Angle Boot • How to Order



Series 80 Mighty Mouse right angle shrink boots provide mechanical and environmental protection from damage and debris. Boots are available in four material options with matched adhesive. Boots are made to fit Glenair Series 80 Mighty Mouse connectors. All adhesive lined and unlined shrink boots are RoHS compliant. Shrink boots are water-tight when equipped with factory installed or user-installed adhesives. Lipped boots lock into boot groove located on adapter or integrated connector backshell. Choose boot size based on adapter or connector accessory thread diameter and cable diameter.

How to Order							
Sample Part Number	809	A	060	-4	H	U	-PP
Product Series	809 = Series 80 shrink boot						
Angular Function	A = 90°						
Basic Number	060 = lipped boot						
Dash Number	1, 2, 3, 4, 5, 6; See dimensions table						
Material	Omit for type 1 H = type 2 L = type 9 S = type 8 see material and adhesive table						
Adhesive Options	Omit for recommended adhesive OR U = no adhesive R = epoxy pre-coat adhesive see material and adhesive table						
Potting Port	PP = potting port Omit for none						

Material and Adhesive				
Material Code (Type)	Compound	Material Description	Recommended Adhesive	Adhesive Option
Omit (Type 1; Standard)	2025	Fluid Resistant Semi-Rigid Elastomer	W1: -55°C to +125°C pre-coat hot melt; high performance	R or U
H (Type 2)	2010	NAVSEA 5617649 ZH/LS Fire Hazard Material	W1: -55°C to +125° pre-coat hot melt; high performance	R or U
G (Type 3)	2040	General-Purpose Flexible Polyolefin	W2: -55°C to +70°C pre-coat hot melt; low temperature	U
V (Type 5)	2050	Viton Fluoroelastomer Blend	W1: -55°C to +125° pre-coat hot melt; high performance	R or U
E (Type 6)	2051	High-Performance Elastomer Polymer Alloy	W1: -55°C to +125° pre-coat hot melt; high performance	U
F (Type 7)	2071	Flexible Polyolefin	W2: -55°C to +70°C pre-coat hot melt; low temperature	U
S (Type 8)	2008	Low Outgassing Fluoropolymer	U: -75°C to +150°C two part epoxy 779-001 two part epoxy, sold separately	None
L (Type 9)	2013	Low Temp Flexible Polyolefin	W2: -55°C to +70°C pre-coat hot melt; low temperature	U
N (Type 11)	2011B	Radiation-Resistant Polyolefin	N/A	U

NOTES

1. See **Modification Codes** listed in Section A for material color options available for **Type 1 (compound 2025)** material.
2. See **Reference Information** pages in this section for material and adhesive selection guides.
3. Recovered dimension apply to unrestricted recovery. Dimensions may differ than shown when boots are installed over assembly.

809A060 Series 80 Mighty Mouse and Series 806 Mil-Aero Right Angle Boot • Dimensions

Lipped Straight Adapter Shrink Boots: Dimensions

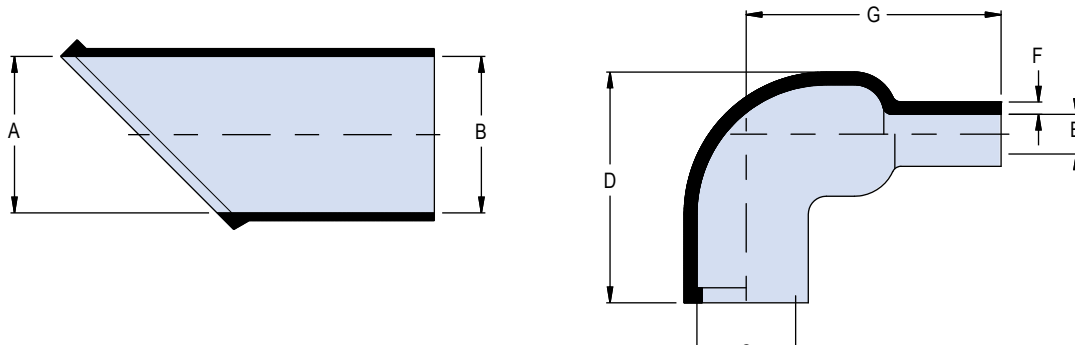

Dimensions												
Dash No.	Shell Size			A Min Dia	B Min Dia	C Max*	D Ref	E Max	F Ref	H Ref*	Cable Range	
	800, 801 802, 803 804	805	806								Max	Min
1	5/6	8	7/8	.390 (9.91)	.390 (9.91)	.26 (6.60)	1.37 (34.80)	.08 (2.03)	.030 (0.76)	.75 (19.05)	.23 (5.84)	.10 (2.54)
2	7	9	9	.669 (16.99)	.669 (16.99)	.30 (7.62)	1.50 (38.10)	.14 (3.56)	.032 (0.81)	.75 (19.05)	.50 (12.70)	.17 (4.32)
3	8/9	10/11	10/11	.945 (24.00)	.945 (24.00)	.39 (9.91)	1.50 (38.10)	.20 (5.08)	.035 (0.89)	.75 (19.05)	.80 (20.32)	.24 (6.10)
4	10/11 12/13	12/13/15	12/14/16	1.181 (30.00)	1.181 (30.00)	.55 (13.97)	2.17 (55.12)	.24 (6.10)	.039 (0.99)	1.18 (29.97)	1.02 (25.91)	.28 (7.11)
5	14/15 16/17	18/19	18	1.260 (32.00)	1.260 (32.00)	.71 (18.03)	2.64 (67.06)	.28 (7.11)	.039 (0.99)	1.30 (33.02)	1.12 (28.45)	.30 (7.62)
6	19/21	21/23	20/22/24	1.417 (35.99)	1.417 (35.99)	.90 (22.86)	3.15 (80.01)	.33 (8.38)	.047 (1.19)	1.57 (39.88)	1.20 (30.48)	.35 (8.89)

For materials Type 2 and Type 9, dimension 'B' is nominal

*Recovered boot dimensions accommodate a band and braid for shielded applications.

Lipped Right Angle Shrink Boots: Part Marking, Raised Lettering

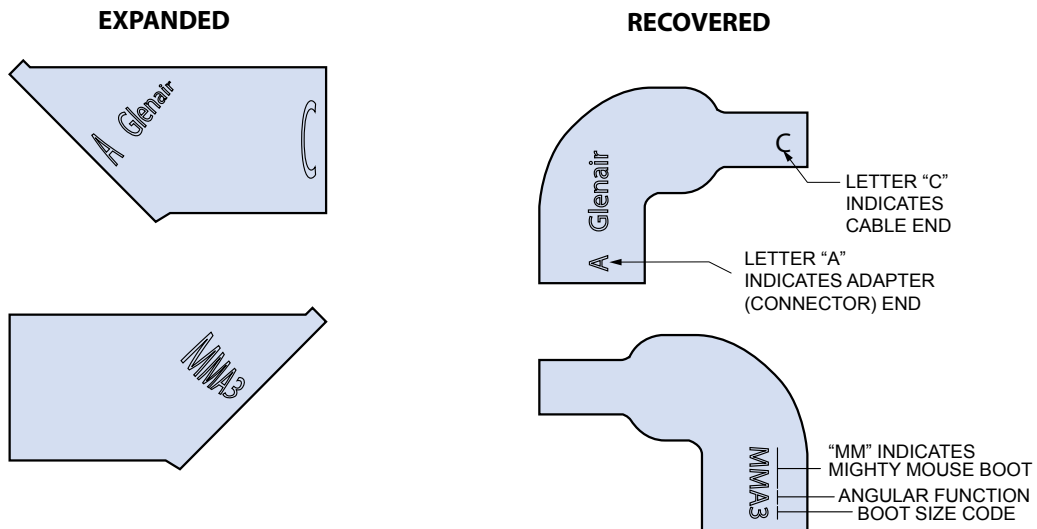

809B060 Series 80 Mighty Mouse and Series 806 Mil-Aero 45° Boot • How to Order



Series 80 Mighty Mouse 45° angle shrink boots provide mechanical and environmental protection from damage and debris. Boots are available in four material options with matched adhesive. Boots are made to fit Glenair Series 80 Mighty Mouse connectors. All adhesive lined and unlined shrink boots are RoHS compliant. Shrink boots are water-tight when equipped with factory installed or user-installed adhesives. Lipped boots lock into boot groove located on adapter or integrated connector backshell. Choose boot size based on adapter or connector accessory thread diameter and cable diameter.

How to Order	
Sample Part Number	809 B 060 -4 H U -PP
Product Series	809 = Series 80 shrink boot
Angular Function	B = 45°
Basic Number	060 = lipped boot
Dash Number	1, 2, 3, 4, 5, 6 ; See dimensions table
Material	Omit for type 1 H = type 2 L = type 9 S = type 8 see material and adhesive table
Adhesive Options	Omit for recommended adhesive OR U = no adhesive R = epoxy pre-coat adhesive see material and adhesive table
Potting Port	PP = potting port Omit for none

Material and Adhesive				
Material Code (Type)	Compound	Material Description	Recommended Adhesive	Adhesive Option
Omit (Type 1; Standard)	2025	Fluid Resistant Semi-Rigid Elastomer	W1 : -55°C to +125°C pre-coat hot melt; high performance	R or U
H (Type 2)	2010	NAVSEA 5617649 ZH/LS Fire Hazard Material	W1 : -55°C to +125° pre-coat hot melt; high performance	R or U
G (Type 3)	2040	General-Purpose Flexible Polyolefin	W2 : -55°C to +70°C pre-coat hot melt; low temperature	U
V (Type 5)	2050	Viton Fluoroelastomer Blend	W1 : -55°C to +125° pre-coat hot melt; high performance	R or U
E (Type 6)	2051	High-Performance Elastomer Polymer Alloy	W1 : -55°C to +125° pre-coat hot melt; high performance	U
F (Type 7)	2071	Flexible Polyolefin	W2 : -55°C to +70°C pre-coat hot melt; low temperature	U
S (Type 8)	2008	Low Outgassing Fluoropolymer	U : -75°C to +150°C two part epoxy 779-001 two part epoxy, sold separately	None
L (Type 9)	2013	Low Temp Flexible Polyolefin	W2 : -55°C to +70°C pre-coat hot melt; low temperature	U
N (Type 11)	2011B	Radiation-Resistant Polyolefin	N/A	U

NOTES

1. See **Modification Codes** listed in Section A for material color options available for **Type 1 (compound 2025)** material.
2. See **Reference Information** pages in this section for material and adhesive selection guides.
3. Recovered dimension apply to unrestricted recovery. Dimensions may differ than shown when boots are installed over assembly.

Lipped 45° Angle Adapter Shrink Boots: Dimensions

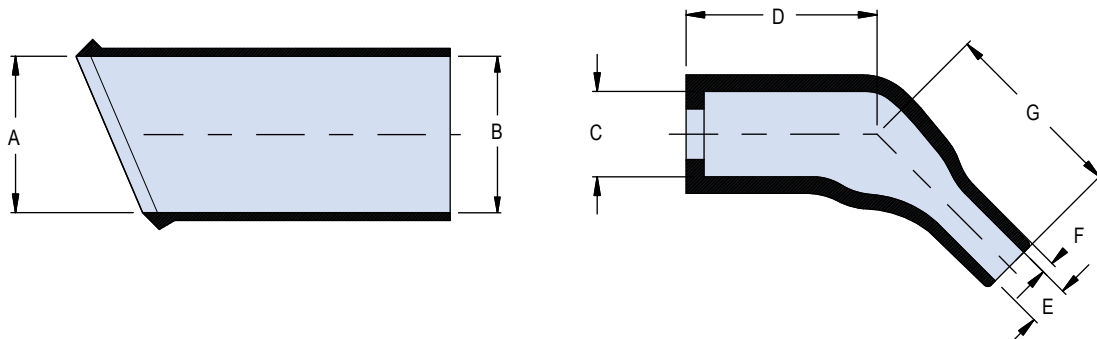

Dimensions												
Dash No.	Shell Size			A Min Dia	B Min Dia	C Max*	D Ref	E Max	F Ref	H Ref*	Cable Range	
	800, 801 802, 803 804	805	806								Max	Min
1	5/6	8	7/8	.390 (9.91)	.390 (9.91)	.26 (6.60)	1.37 (34.80)	.08 (2.03)	.030 (0.76)	.75 (19.05)	.23 (5.84)	.10 (2.54)
2	7	9	9	.669 (16.99)	.669 (16.99)	.30 (7.62)	1.50 (38.10)	.14 (3.56)	.032 (0.81)	.75 (19.05)	.50 (12.70)	.17 (4.32)
3	8/9	10/11	10/11	.945 (24.00)	.945 (24.00)	.39 (9.91)	1.50 (38.10)	.20 (5.08)	.035 (0.89)	.75 (19.05)	.80 (20.32)	.24 (6.10)
4	10/11 12/13	12/13/15	12/14/16	1.181 (30.00)	1.181 (30.00)	.55 (13.97)	2.17 (55.12)	.24 (6.10)	.039 (0.99)	1.18 (29.97)	1.02 (25.91)	.28 (7.11)
5	14/15 16/17	18/19	18	1.260 (32.00)	1.260 (32.00)	.71 (18.03)	2.64 (67.06)	.28 (7.11)	.039 (0.99)	1.30 (33.02)	1.12 (28.45)	.30 (7.62)
6	19/21	21/23	20/22/24	1.417 (35.99)	1.417 (35.99)	.90 (22.86)	3.15 (80.01)	.33 (8.38)	.047 (1.19)	1.57 (39.88)	1.20 (30.48)	.35 (8.89)

For materials Type 2 and Type 9, dimension 'B' is nominal

*Recovered boot dimensions accommodate a band and braid for shielded applications.

Lipped 45° angle Shrink Boots: Part Marking, Raised Lettering

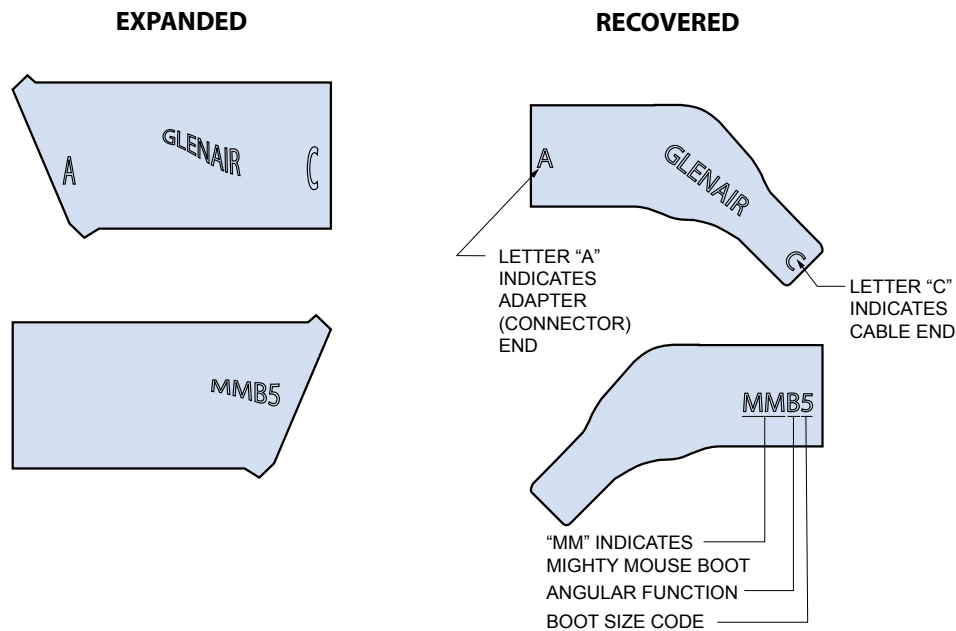

809SL060 Series 80 Mighty Mouse and Series 806 Mil-Aero Straight Long Tail Boot • How to Order



Series 80 Mighty Mouse straight long tail shrink boots provide mechanical and environmental protection from damage, debris and additional strain relief compared to standard length boots. Available in four material options with matched adhesive. Boots are made to fit Glenair Series 80 Mighty Mouse connectors. All adhesive lined and unlined shrink boots are RoHS compliant. Shrink boots are water-tight when equipped with factory installed or user-installed adhesives. Lipped boots lock into boot groove located on adapter or integrated connector backshell. Choose boot size based on adapter or connector accessory thread diameter and cable diameter.

How to Order						
Sample Part Number	809	SL	060	-2	H	U
Product Series	809 = Series 80 shrink boot					
Angular Function	SL = straight long tail					
Basic Number	060 = lipped boot					
Dash Number	1, 2, 3, 4; See dimensions table					
Material	Omit for type 1 H = type 2 L = type 9 S = type 8 see material and adhesive table					
Adhesive	Omit for recommended adhesive OR U = no adhesive R = epoxy pre-coat adhesive see material and adhesive table					

Material and Adhesive				
Material Code (Type)	Compound	Material Description	Recommended Adhesive	Adhesive Option
Omit (Type 1; Standard)	2025	Fluid Resistant Semi-Rigid Elastomer	W1: -55°C to +125°C pre-coat hot melt; high performance	R or U
H (Type 2)	2010	NAVSEA 5617649 ZH/LS Fire Hazard Material	W1: -55°C to +125° pre-coat hot melt; high performance	R or U
G (Type 3)	2040	General-Purpose Flexible Polyolefin	W2: -55°C to +70°C pre-coat hot melt; low temperature	U
V (Type 5)	2050	Viton Fluoroelastomer Blend	W1: -55°C to +125° pre-coat hot melt; high performance	R or U
E (Type 6)	2051	High-Performance Elastomer Polymer Alloy	W1: -55°C to +125° pre-coat hot melt; high performance	U
F (Type 7)	2071	Flexible Polyolefin	W2: -55°C to +70°C pre-coat hot melt; low temperature	U
S (Type 8)	2008	Low Outgassing Fluoropolymer	U: -75°C to +150°C two part epoxy 779-001 two part epoxy, sold separately	None
L (Type 9)	2013	Low Temp Flexible Polyolefin	W2: -55°C to +70°C pre-coat hot melt; low temperature	U
N (Type 11)	2011B	Radiation-Resistant Polyolefin	N/A	U

NOTES

1. See **Modification Codes** listed in Section A for material color options available for **Type 1 (compound 2025)** material.
2. See **Reference Information** pages in this section for material and adhesive selection guides.
3. Recovered dimension apply to unrestricted recovery. Dimensions may differ than shown when boots are installed over assembly.

809SL060 Series 80 Mighty Mouse and Series 806 Mil-Aero Straight Long Tail Boot • Dimensions

Lipped Straight Long Tail Adapter Shrink Boots: Dimensions

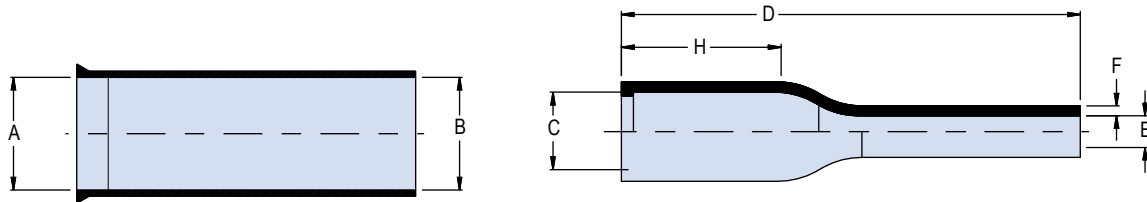

Dimensions												
Dash No.	Shell Size			A Min Dia	B Min Dia	C Max*	D Ref	E Max	F Ref	H Ref*	Cable Range	
	800, 801 802, 803 804	805	806								Max	Min
1	5/6	8	7/8	.390 (9.91)	.390 (9.91)	.26 (6.60)	1.37 (34.80)	.08 (2.03)	.030 (0.76)	.75 (19.05)	.23 (5.84)	.10 (2.54)
2	7	9	9	.669 (16.99)	.669 (16.99)	.31 (7.87)	1.50 (38.10)	.14 (3.56)	.032 (0.81)	.75 (19.05)	.50 (12.70)	.17 (4.32)
3	8/9	10/11	10/11	.945 (24.00)	.945 (24.00)	.39 (9.91)	1.50 (38.10)	.20 (5.08)	.035 (0.89)	.75 (19.05)	.80 (20.32)	.24 (6.10)
4	10/11 12/13	12/13/15	12/14/16	1.181 (30.00)	1.181 (30.00)	.55 (13.97)	2.17 (55.12)	.24 (6.10)	.039 (0.99)	1.18 (29.97)	1.02 (25.91)	.28 (7.11)

For materials Type 2 and Type 9, dimension 'B' is nominal



Lipped Straight Long Tail Shrink Boots: Part Marking, Raised Lettering

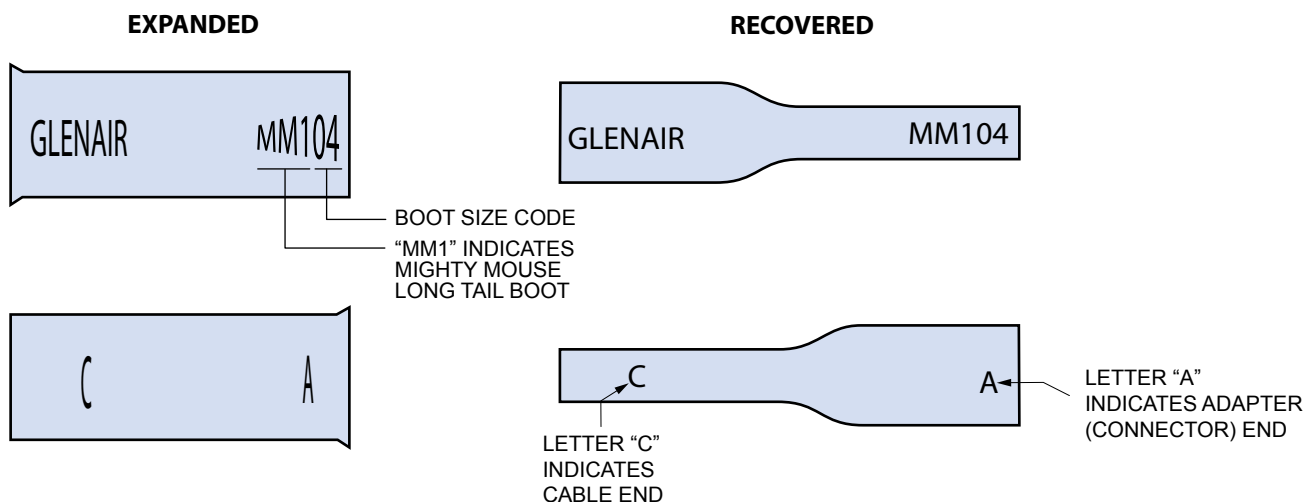

Series Specific Heat Shrink Boots



809SU060 Series 80 Mighty Mouse and Series 806 Mil-Aero Straight UTM, USB Boot - How to Order



Series 80 Mighty Mouse straight USB shrink boots provide mechanical and environmental protection from damage and debris. USB shrink boots are specifically developed for installation onto USB cables where higher installation temperatures can cause damage to USB cable. Boots are made to fit Glenair Series 80 Mighty Mouse connectors. All adhesive lined and unlined shrink books are RoHS compliant. Shrink boots are water-tight when equipped with factory installed or user-installed adhesives. Lipped boots lock into boot groove located on adapter or integrated connector backshell. Choose boot size based on adapter or connector accessory thread diameter and cable diameter.

How to Order					
Sample Part Number	809	SU	060	-1	-U
Product Series	809 = Series 80 shrink boot				
Angular Function	SU = straight, USB				
Basic Number	060 = lipped Boot				
Dash Number	1; See dimensions Table				
Adhesive	U = No adhesive pre-coat Omit for W2; see material and adhesive table				

E

Material and Adhesive			
Material Code (Type)	Compound	Material Description	Adhesive Code
Omit (Type 9)	2013	Low Temp Flexible Polyolefin	W2: - 55°C to +70°C pre-coat hot melt; low temperature

Lipped USB Adapter Shrink Boots: Dimensions

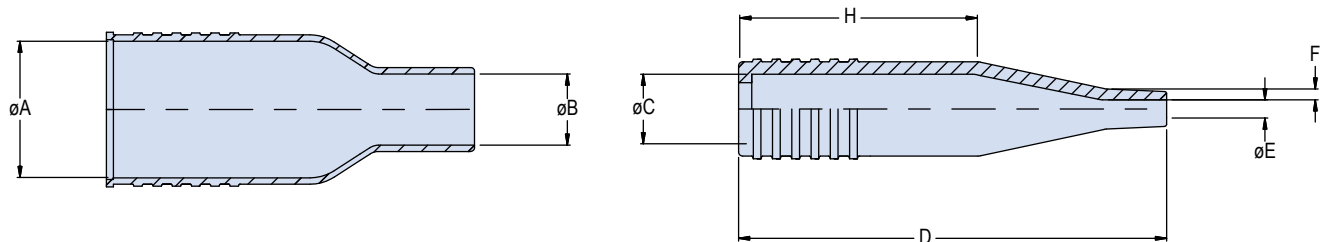

Dimensions										
Dash No.	Shell Size	A	B	C	D	E	F	H	Cable Range	
	801, 804, 805, 806	Min Dia	Min Dia	Max	Ref	Max	Ref	Ref	Max	Min
1	7, 8	.550 (13.97)	.360 (9.14)	.33 (8.38)	2.00 (50.8)	.09 (2.29)	.055 (1.40)	1.13 (28.70)	.25 (6.35)	.09 (2.29)

Dimension 'B' is nominal

Lipped USB Adapter Shrink Boots: Part Marking, Raised Lettering



EXPANDED

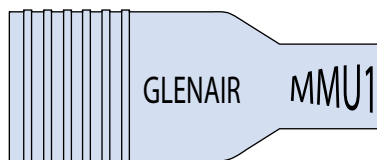

RECOVERED



BOOT SIZE CODE
"U" INDICATES USB
"MM" INDICATES
MIGHTY MOUSE BOOT

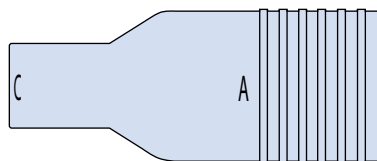

LETTER "C"
INDICATES
CABLE END

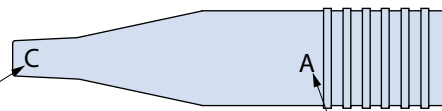

LETTER "A"
INDICATES ADAPTER
(CONNECTOR) END

SERIES 77
HEAT SHRINK
TRANSITIONS

CABLE ROUTING

WYE and TEE heat shrinkable boot transitions for cable management and routing solutions

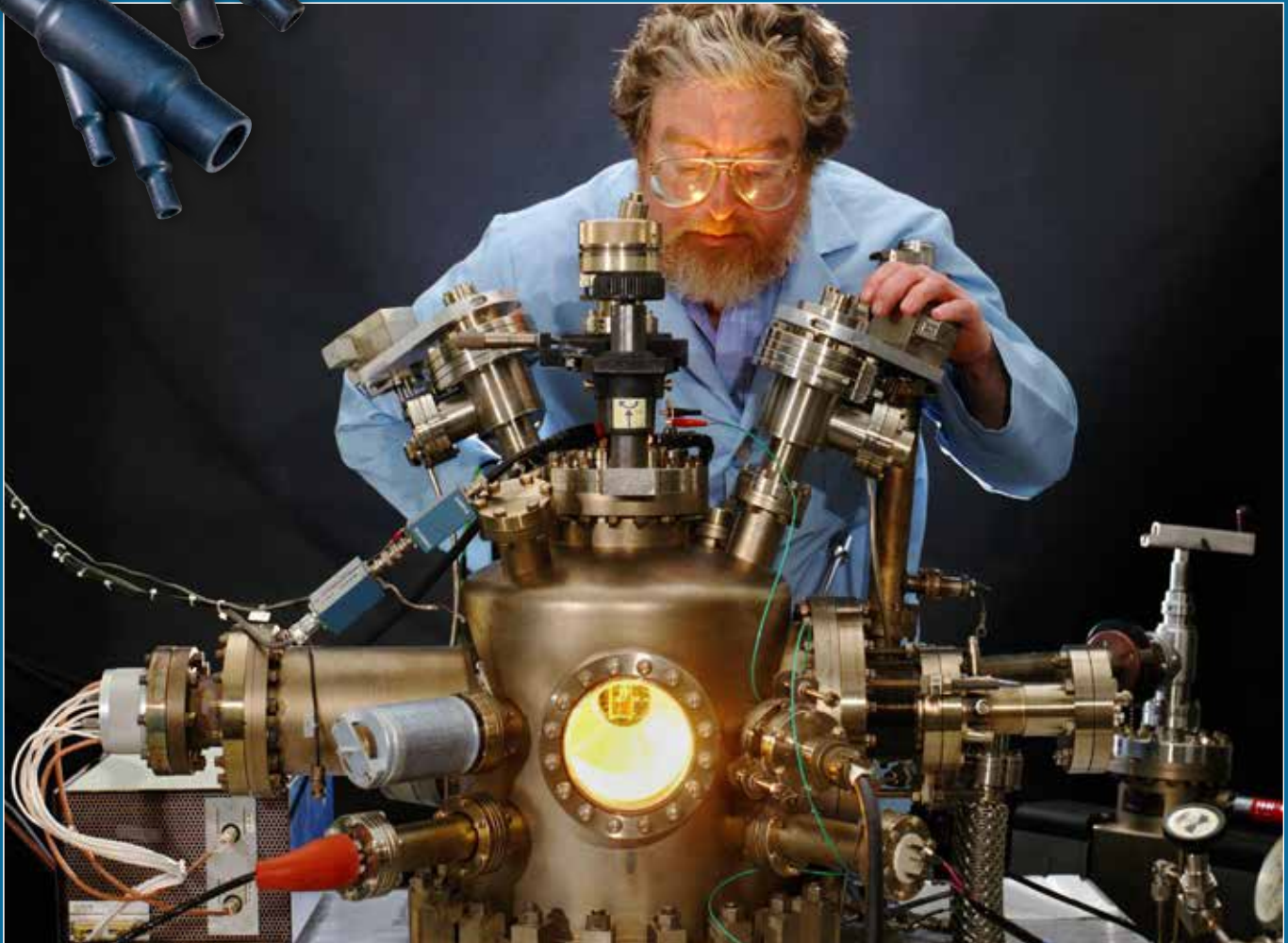

Glenair Series 77 heat shrinkable transitions provide cable designers with complete flexibility and versatility in cable routing and harness design. Wye, Tee, and Breakout transitions are available. Wye and Tee transitions come in low-profile and widebody versions (for larger cable diameters), these environmental transitions reduce cable assembly time and provide turnkey sealing and routing in multi-legged harnesses. Available in eight material types, including Viton® for continuous exposure to caustic chemicals and fuels. Our popular Type 1 high-performance elastomer is ideal for extreme temperatures with excellent resistance to fuels and oils, and can be ordered in one of ten optional color choices.



Glenair, Inc.
1211 Air Way
Glendale, CA 91201-2497
818-247-6000
sales@glenair.com
www.glenair.com



SERIES 77
Heat Shrink Transitions
Product Selection Guide



Boot Selection and Reference Guide F-2



“Wye”, 1:3, and 1:4 Transitions F-4



“Tee” Transitions F-16

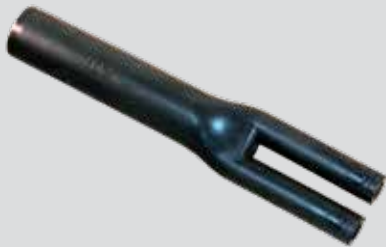

Parallel Transitions F-20



Angled “Tee” Transitions F-22





SERIES 77
Heat Shrink Transitions



Shrink Boot Selection and Reference Guide

Heat Shrinkable Transitions



- Eight material options
- Four adhesive options
- With or without potting ports or drain holes
- Non-adhesive lined boots (For use with Type U two-part epoxy):

Glenair Series 77 heat shrinkable transitions provide cable designers with complete flexibility and versatility in cable routing and harness design. Available in both low-profile as well as widebody version (for larger cable diameters), these environmental transitions reduce cable assembly time and provide turnkey sealing and routing in multi-legged harnesses. Available in eight material types, including Viton® for continuous exposure to caustic chemicals and fuels, as well as our popular Type 1 high-performance elastomer for extreme temperatures, excellent resistance to fuels and oils, and the option of choosing from ten available colors.

Recommended Material Selection

Type 1 high performance, semi-rigid elastomer for extreme temperatures and excellent resistance to fuels and oils and rated for 3000 hours continuous operation at +150°C. Material meets requirements of VG95343 Type 6, BSG 198-5-DE, EN62329-102 and SAE AS5258 Type H.

Type 2 semi-flexible low smoke zero halogen (LSZH) flame-retarded polyolefin meets low smoke and toxicity requirements of shipboard, transit and aircraft systems and rated for 3000 hours continuous operation at +130° C. Temperature rating -40° C to +130°C

Type 3 self extinguishing, flexible polyolefin boots meet SAE AS8176581 Type II requirements and offers good resistance to oils and fuels. Good all around general duty shrink boot solution. Temperature rating of -55° C to +135°C.

Type 5 flexible Viton® Fluoroelastomer boot for extreme temperatures where excellent resistance to fuels, fluids, solvents is needed. Temperature rating of -55° C to +150°C. Material meets the requirements of SC-X15111D.

Type 6 high performance, flexible elastomer alloy are well suited for high temperatures within areas prone to oil and fluid exposure. Temperature rating of -55° to +135°C.

Type 7 highly flexible polyolefin boots are well suited for high temperatures within areas prone to oil and fluid exposure. Temperature rating of -55° to +135°C.

Type 8 semi-rigid, low outgassing fluoropolymer alloy meets NASA low out-gassing test requirements and are suitable for high altitude and space applications. Excellent resistance to oils, fuels, solvents, acids and bases. Broad operating temperature of -50° C to +150° C provides excellent high temperature stability and low temperature flexibility for extreme temperatures.

Type 9 low temp application, flexible polyolefin for Ethernet and USB cables susceptible to heat damage from the application of boots with higher minimum shrink temperatures. Resistance to oils, fuels, solvents, acids and bases is fair. Temperature rating of -40° to +100°C.



Part Number
779-001



Part Number
779-002



Part Number	Package Size
779-003	12

See Section G for complete installation guide

F



SERIES 77
Heat Shrink Transitions



Shrink Boot Selection and Reference Guide

Glenair® transitions provide protection and cable routing advantages for wire assemblies.



Angled "Tee" Transition



Low-Profile "Wye"



Widebody "Wye"



Low-Profile "Tee"



Widebody "Tee"



Low-Profile 1:3



Widebody 1:3



Widebody 1:4

- Versatile Cable/Wire Routing
- 8 Material Types
- Ten Colors Available in the Type 1 High Performance Elastomer Material
- Adhesive and Non-Adhesive Versions



"Wye" and "Tee" Transitions for Every Cable Routing Requirement

Pre-Coated Boots Adhesive Information

Attribute	W1 High Performance Adhesive	W2 Low Temp Adhesive	W3 TACOM Approved Adhesive	R High Performance Epoxy Adhesive	779-001 Two Part Epoxy Adhesive
Boot Material Compatibility	Types 1, 2, 5, 6 and 7	Types 1, 2, 3, 7 and 9	Types 5 and 6	Type 1, 2 and 5	All Material Types
Continuous Operating Temp.	-55° to +125°C	-55° to +70°C	-55° to +125°C	-75° to +150°C	-75° to +150°C
Resistance to Fuels, Oils, and Fluids	Good	Good	Good	Excellent	Excellent
Low Toxicity, Zero Halogen	Yes	Yes	No	Yes	Yes



SERIES 77 Heat Shrink Transitions



770-009 Low Profile Heat Shrink “TACOM” Approved “Wye” Transition - How to Order



Low profile “Wye” heat shrink transitions provide an easy to instal and rugged cable routing solution. Transitional boots are available in eight material options with five adhesive choices. All Adhesive lined and unlined shrink books are RoHS compliant. Transitional boots are water-tight when equipped with factory installed or user-installed adhesive. Choose boot size based on cable diameter.

How to Order						
Sample Part Number		770	-009	Y	1	05 W1
Product Series	770 = Series 77 shrink boot					
Basic Number	009 = Basic number					
Angular Function	Y = “Wye” transition					
Material	See material and adhesives table					
Boot Size	04, 05, 06, 07, 08, 07-01, 08-01					
Adhesive Lined	W1, W2, W3, R, U, Omit for no adhesive; see material and adhesives table for compatibility					

Material and Adhesive Compatibility							
Material Code	Material Description (Compound No.)	Hot Melt Adhesives			High Performance Epoxy Adhesives		
		W1	W2	W3 (TACCOM approved)	R	U	
		High Temperature -55°C to 125°C	Standard -55°C to 70°C	Elastomeric -55°C to 125°C	Pre-Coat -75°C to 150°C	Two-Part -75°C to 155°C	
1	High-Performance Semi-Rigid Elastomer (2025)	●	●		●	Type U epoxy adhesive is compatible with all boot materials. Ordered separately, user-installed (779-001). Order boot with no adhesive lining.	
2	Zero Halogen Semi-Rigid Polyolefin (2010)	●	●		●		
3	General Purpose Flexible Polyolefin (2040)		●				
5	Viton Fluoroelastomer Blend (2050)	●		●	●		
6	High Performance Elastomer Alloy (2051)	●		●			
7	Semi-Rigid Polyolefin (2071)	●	●				
8	Low Outgassing Fluoropolymer Alloy (2008)	Material Type 8 not available with pre-coat adhesive. Use Type U two-part epoxy					
9	Low Temp Flexible Polyolefin (2013)		●				

NOTES

1. See **Modification Codes** listed in Section A for material color options available for **Type 1 (compound 2025)** material.
2. Recovered dimension apply to unrestricted recovery. Dimensions may differ than shown when boots are installed over assembly.



SERIES 77 Heat Shrink Transitions



770-009 Low Profile Heat Shrink “TACOM” Approved “Wye” Transition - Dimensions

“Wye” Heat Shrink Transition: Dimensions

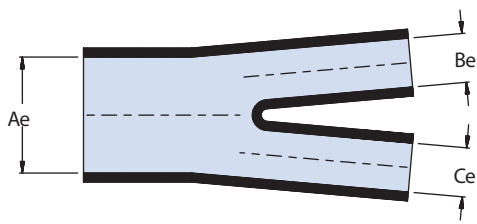

EXPANDED

SIZES
05-08

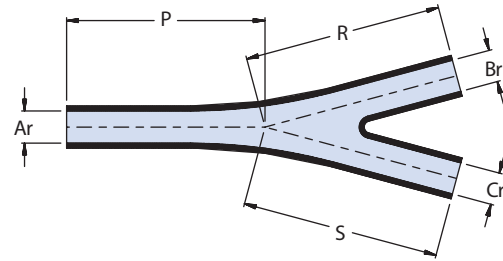

RECOVERED

Dimensions										
Size	Glenair US Part Marking	GDLS (REF)	GD/TACOM (REF)	Lockheed Martin JSFQ27	Ae Min. Dia.	Be, Ce Dia Min. Dia.	Ar, Br, Cr Max. Dia.		P ± 10%	R, S Ref.
04	Y04				.600 (15.2)	.350 (8.9)	.190(4.83) Ar	.100 (2.54) Br, Cr	1.280 (32.5)	1.280 (32.5)
05	Y05	10652590-1	12273148-1**	Y1	.780 (19.8)	.520 (13.2)	.260 (6.6)		1.600 (40.6)	1.600 (40.6)
06	Y06	10652590-2	12273148-2**	Y2	1.350 (34.3)	.900 (22.9)	.450 (11.4)		2.480 (63.0)	2.480 (63.0)
07	Y07	10652590-3	12273148-5**	Y3	2.370 (60.2)	1.580 (40.1)	.791 (20.1)		3.730 (94.7)	3.730 (94.7)
08	Y08	10652590-4		Y4	3.280 (83.3)	2.161 (54.9)	1.311 (33.3)		5.270 (133.9)	5.270 (133.9)
07-01	Y07-01	10652590-5	12273148-3**		2.370 (60.2)	1.580 (40.1)	.791 (20.1)		2.480 (63.0)	2.480 (63.0)
08-01	Y08-01	10652590-6	12273148-4**		3.280 (83.3)	2.161 (54.9)	1.311 (33.3)		3.730 (94.7)	3.730 (94.7)



“Wye” Heat Shrink Transition: Part Marking, Raised Lettering

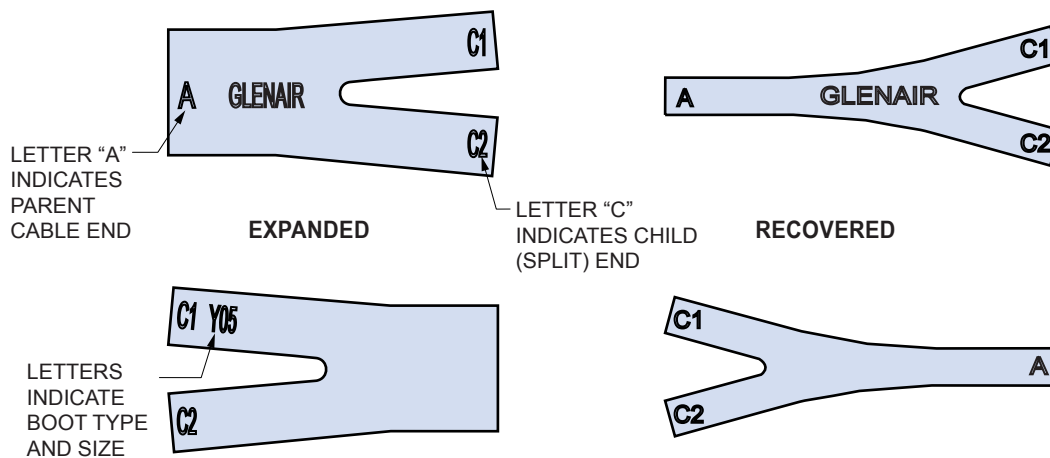



SERIES 77 Heat Shrink Transitions



770-009 Low Profile, Heat Shrink Reduced “Wye” Transition, Size 16, 26 and 36 - How to Order



Low profile “Wye” heat shrink reduced transition boot provide an easy to install and rugged cable routing solution. Transitional boots with reduced leg to accommodate smaller exiting cable bundle. Material is available in eight options and five adhesive choices. All Adhesive lined and unlined shrink books are RoHS compliant. Transitional boots are water-tight when equipped with factory installed or user-installed adhesive. Choose boot size based on cable diameter.

How to Order							
Sample Part Number		770	-009	Y	1	16	W1
Product Series	770 = Series 77 shrink boot						
Basic Number	009 = Basic number						
Angular Function	Y = “Wye” transition						
Material	See material and adhesives table						
Boot Size	16, 26, 36; Based on cable diameter						
Adhesive Lined	W1, W2, W3, R, U, Omit for no adhesive; see material and adhesives table for compatibility						

Material and Adhesive Compatibility							
Material Code	Material Description (Compound No.)	Hot Melt Adhesives			High Performance Epoxy Adhesives		
		W1	W2	W3 (TACCOM approved)	R	U	
		High Temperature -55°C to 125°C	Standard -55°C to 70°C	Elastomeric -55°C to 125°C	Pre-Coat -75°C to 150°C	Two-Part -75°C to 155°C	
1	High-Performance Semi-Rigid Elastomer (2025)	●	●		●	Type U epoxy adhesive is compatible with all boot materials. Ordered separately, user-installed (779-001). Order boot with no adhesive lining.	
2	Zero Halogen Semi-Rigid Polyolefin (2010)	●	●		●		
3	General Purpose Flexible Polyolefin (2040)		●				
5	Viton Fluoroelastomer Blend (2050)	●		●	●		
6	High Performance Elastomer Alloy (2051)	●		●			
7	Semi-Rigid Polyolefin (2071)	●	●				
8	Low Outgassing Fluoropolymer Alloy (2008)	Material Type 8 not available with pre-coat adhesive. Use Type U two-part epoxy					
9	Low Temp Flexible Polyolefin (2013)		●				

NOTES

1. See **Modification Codes** listed in Section A for material color options available for **Type 1 (compound 2025)** material.
2. Recovered dimension apply to unrestricted recovery. Dimensions may differ than shown when boots are installed over assembly.



SERIES 77 Heat Shrink Transitions



770-009 Low Profile, Heat Shrink Reduced “Wye” Transition, Size 16, 26 and 36 - Dimensions

“Wye” Heat Shrink Transition: Dimensions

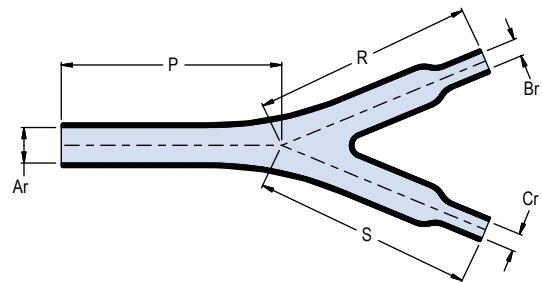
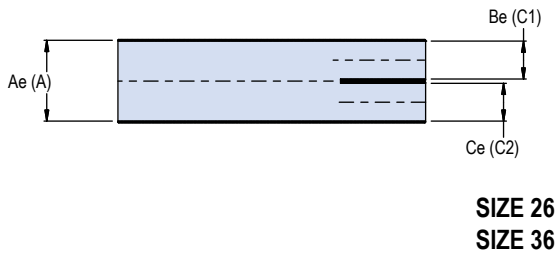
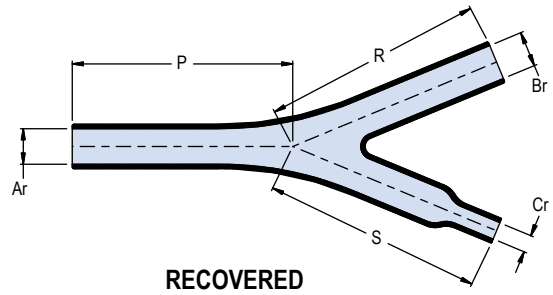
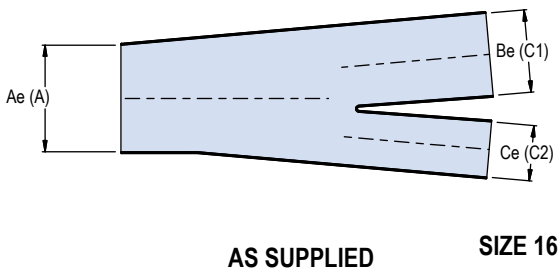

Dimensions									
Size	Glenair Us Part Marking	Ae Min Dia	Be Min Dia	Ce Min Dia	Ar Max Dia	Br Max Dia	Cr ±10%	P ±10%	R, S Ref
16	Y16	1.200(30.5)	.900(22.9)	.600(15.2)	.450(11.4)	.450(11.4)	.300(7.6)	2.480(63.0)	2.480(63.0)
26	Y26	.900(22.9)	.400(10.2)	.400(10.2)	.450(11.4)	.200(5.1)	.200(5.1)	2.480(63.0)	2.480(63.0)
36	Y36	1.000(25.4)	.600(15.2)	.600(15.2)	.450(11.4)	.300(7.6)	.300(7.6)	2.480(63.0)	2.480(63.0)



“Wye” Heat Shrink Transition: Part Marking, Raised Lettering

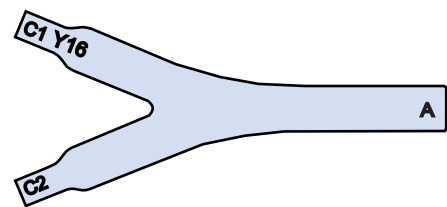
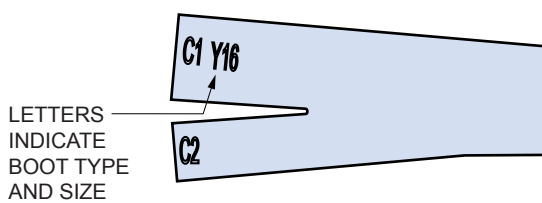
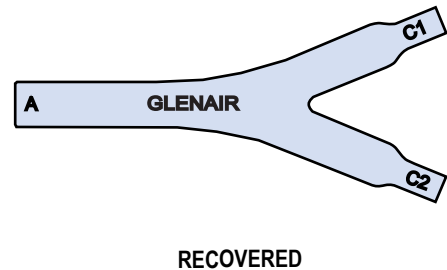
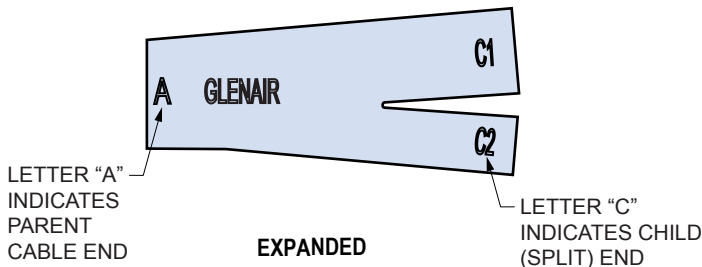



SERIES 77 Heat Shrink Transitions



770-010 Wide Body, Heat Shrink “Wye” Transition How to Order



Low Profile “Wye” heat shrink transitions provide an easy to repair and rugged cable routing solution. Transitional boots are available in eight material options with five adhesive choices. All Adhesive lined and unlined shrink boots are RoHS compliant. Transitional boots are water-tight when equipped with factory installed or user-installed adhesive. Choose boot size based on cable diameter.

How to Order							
Sample Part Number	770	-010	Y	1	05	W1	-PP
Product Series	770 = Series 77 shrink boot						
Basic Number	010 = Basic number						
Angular Function	Y = “Wye” transition						
Material	See material and adhesives table						
Boot Size	05, 06, 07, 08 Based on cable diameter						
Adhesive Lined	W1, W2, W3, R, U, Omit for no adhesive; see material and adhesives table for compatibility						
Potting Ports	PP = Potting Ports Omit for none						

Material and Adhesive Compatibility							
Material Code	Material Description (Compound No.)	Hot Melt Adhesives			High Performance Epoxy Adhesives		
		W1	W2	W3 (TACCOM approved)	R	U	
		High Temperature -55°C to 125°C	Standard -55°C to 70°C	Elastomeric -55°C to 125°C	Pre-Coat -75°C to 150°C	Two-Part -75°C to 155°C	
1	High-Performance Semi-Rigid Elastomer (2025)	●	●		●	Type U epoxy adhesive is compatible with all boot materials. Ordered separately, user-installed (779-001). Order boot with no adhesive lining.	
2	Zero Halogen Semi-Rigid Polyolefin (2010)	●	●		●		
3	General Purpose Flexible Polyolefin (2040)		●				
5	Viton Fluoroelastomer Blend (2050)	●		●	●		
6	High Performance Elastomer Alloy (2051)	●		●			
7	Semi-Rigid Polyolefin (2071)	●	●				
8	Low Outgassing Fluoropolymer Alloy (2008)	Material Type 8 not available with pre-coat adhesive. Use Type U two-part epoxy					
9	Low Temp Flexible Polyolefin (2013)		●				

NOTES

- See **Modification Codes** listed in Section A for material color options available for **Type 1 (compound 2025)** material.
- Recovered dimension apply to unrestricted recovery. Dimensions may differ than shown when boots are installed over assembly.

Boot Size Cross Reference			
Boot Size	Glenair US Part Marking	AS85049 /142 Figure 2	LockHeed JSFQ38 JSFQ50
05	Y05	05	-1
06	Y06	06	-2
07	Y07	07	-3
08	Y08	08	-4



SERIES 77
Heat Shrink Transitions



770-010 Wide Body, Heat Shrink “Wye” Transition
Dimensions

“Wye” Heat Shrink Transition: Dimensions

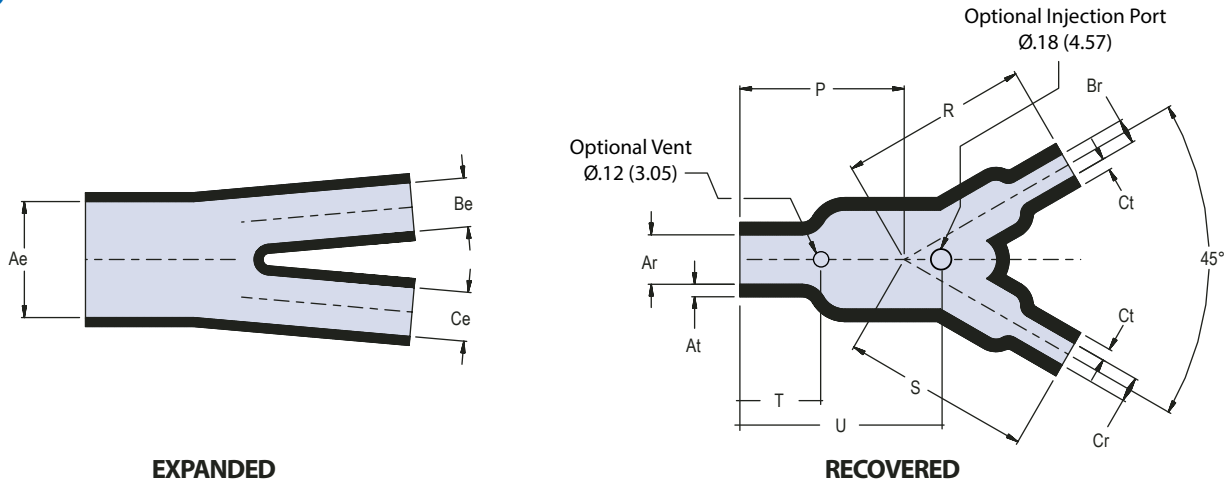

EXPANDED

RECOVERED

Dimensions											
Size	Glenair US Part Marking	Ae Min Dia	Be, Ce Min Dia	Ar Max Dia	Br, Cr Max Dia	At ±20%	Ct ±20%	P ±10%	R, S Ref	T ±10%	U ±10%
05	Y05	.52 (13.2)	.26 (6.6)	.24 (6.1)	.13 (3.3)	.06 (1.5)	.04 (1.0)	.88 (22.4)	.76 (19.3)	.61 (15.5)	.94 (23.9)
06	Y06	1.06 (26.9)	.51 (13.0)	.49 (12.4)	.24 (6.1)	.10 (2.5)	.06 (1.5)	1.50 (38.1)	1.69 (42.9)	1.30 (33.0)	2.10 (53.3)
07	Y07	1.52 (38.6)	1.06 (26.9)	.71 (18.0)	.49 (12.4)	.12 (3.0)	.09 (2.3)	2.58 (65.5)	3.19 (81.0)	2.20 (55.9)	3.10 (78.7)
08	Y08	2.19 (55.6)	1.06 (26.9)	1.02 (25.9)	.52 (13.2)	.18 (4.6)	.10 (2.5)	3.35 (85.1)	3.70 (94.0)	2.80 (71.1)	4.40 (111.8)

“Wye” Heat Shrink Transition: Part Marking, Raised Lettering

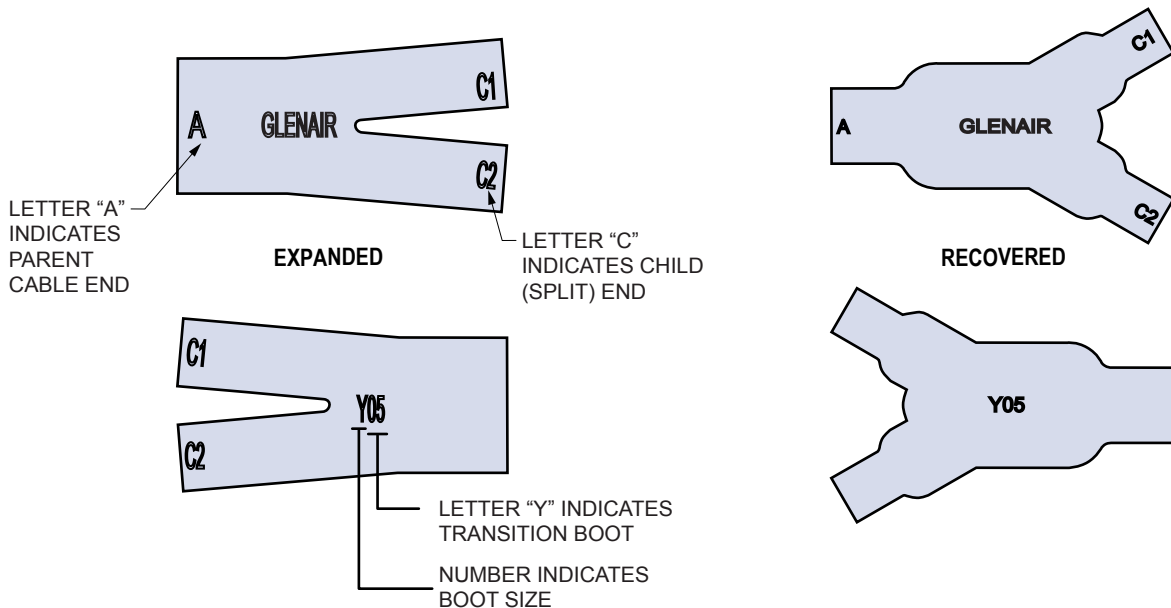



SERIES 77 Heat Shrink Transitions



770-013 1:3 Wide Body Heat Shrink Transition How to Order



1:3 wide body transition heat shrink transitions provide an easy to install and rugged cable routing solution. Transitional boots are available in eight material options with five adhesive choices. All Adhesive lined and unlined shrink books are RoHS compliant. Transitional boots are water-tight when equipped with factory installed or user-installed adhesive. Choose boot size based on cable diameter.

How to Order						
Sample Part Number		770	-013	1	09	W1 -PP
Product Series	770 = Series 77 shrink boot					
Basic Number	013 = Basic number					
Material	See material and adhesives table					
Boot Size	09, 10, 11, 12, 13 Based on cable diameter					
Adhesive Lined	W1, W2, W3, R, U, Omit for no adhesive; see material and adhesives table for compatibility					
Potting Port	PP = Potting Ports/Vent Ports Omit for none					

Material and Adhesive Compatibility						
Material Code	Material Description (Compound No.)	Hot Melt Adhesives			High Performance Epoxy Adhesives	
		W1	W2	W3 (TACCOM approved)	R	U
		High Temperature -55°C to 125°C	Standard -55°C to 70°C	Elastomeric -55°C to 125°C	Pre-Coat -75°C to 150°C	Two-Part -75°C to 155°C
1	High-Performance Semi-Rigid Elastomer (2025)	●	●		●	Type U epoxy adhesive is compatible with all boot materials. Ordered separately, user-installed (779-001). Order boot with no adhesive lining.
2	Zero Halogen Semi-Rigid Polyolefin (2010)	●	●		●	
3	General Purpose Flexible Polyolefin (2040)		●			
5	Viton Fluoroelastomer Blend (2050)	●		●	●	
6	High Performance Elastomer Alloy (2051)	●		●		
7	Semi-Rigid Polyolefin (2071)	●	●			
8	Low Outgassing Fluoropolymer Alloy (2008)	Material Type 8 not available with pre-coat adhesive. Use Type U two-part epoxy				
9	Low Temp Flexible Polyolefin (2013)		●			

NOTES

1. See **Modification Codes** listed in Section A for material color options available for **Type 1 (compound 2025)** material.
2. Recovered dimension apply to unrestricted recovery. Dimensions may differ than shown when boots are installed over assembly.



SERIES 77 Heat Shrink Transitions



770-013 1:3 Wide Body Heat Shrink Transition Dimensions

1:3 Heat Shrink Transition: Dimensions

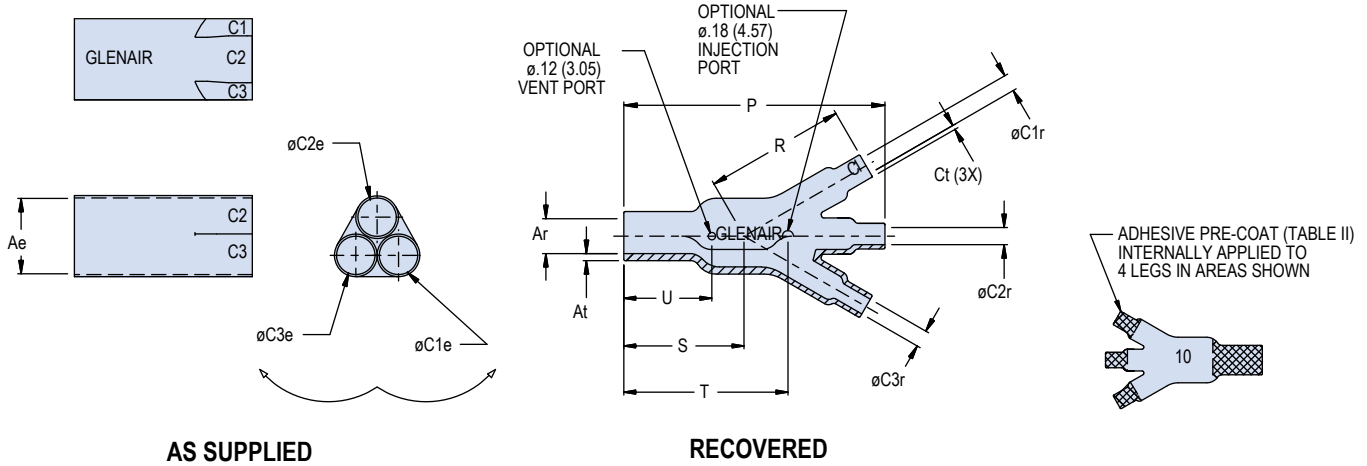

Dimensions													
Size	Glenair US Part Marking	SA85049 /142 Figure 3 Ref	Ae Min Dia	C1e, C2e, C3e Min Dia	Ar Max Dia	C1r, C2r, C3r Max Dia	At ±20%	Ct ±20%	P ±10%	R Ref	S Ref	U (As Recovered) ±10	T (As Recovered) ±10
09	09	09	.52 (13.2)	.26 (6.6)	.26 (6.6)	.14 (3.6)	.06 (1.5)	.04 (1.0)	1.82 (46.2)	1.00 (25.4)	.82 (20.8)	0.62 (15.7)	1.20 (30.5)
10	10	10	1.06 (26.9)	.51 (13.0)	.53 (13.5)	.28 (7.1)	.10 (2.5)	.06 (1.5)	3.67 (93.2)	1.98 (50.3)	1.69 (42.9)	1.30 (33.0)	2.25 (57.2)
11	11	11	1.52 (38.6)	.76 (19.3)	.75 (19.1)	.39 (9.9)	.12 (3.0)	.07 (1.8)	5.32 (135.1)	2.90 (73.7)	2.42 (61.5)	1.80 (45.7)	3.50 (88.9)
12	12	12	2.19 (55.6)	1.06 (26.9)	1.00 (25.4)	.49 (12.4)	.18 (4.6)	.12 (3.0)	7.56 (192.0)	4.06 (103.1)	3.50 (88.9)	2.80 (71.1)	4.80 (121.9)
13	13	13	3.60 (91.4)	1.80 (45.7)	2.15 (54.6)	1.08 (27.4)	.28 (7.1)	.18 (4.6)	15.37 (390.4)	8.31 (211.1)	7.06 (179.3)	5.00 (127.0)	10.0 (254.0)

1:3 Heat Shrink Transition: Part Marking, Raised Lettering

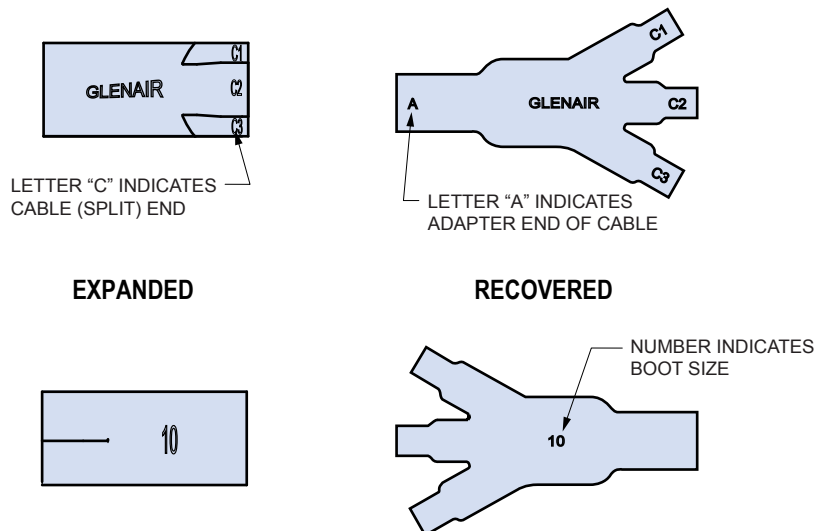



SERIES 77 Heat Shrink Transitions



770-014 1:3, Low Profile, Heat Shrink Transition How to Order



Low profile 1:3 heat shrink transitions provide an easy to install and rugged cable routing solution. Transitional boots are available in eight material options with five adhesive choices. All Adhesive lined and unlined shrink books are RoHS compliant. Transitional boots are water-tight when equipped with factory installed or user-installed adhesive. Choose boot size based on cable diameter.

How to Order					
Sample Part Number		770	-014	1	09 W1
Product Series	770 = Series 77 shrink boot				
Basic Number	014 = Basic number				
Material	See material and adhesives table				
Boot Size	09, 10, 11, 11-01, 12, 12-01 Based on cable diameter				
Adhesive Lined	W1, W2, W3, R, U, Omit for no adhesive; see material and adhesives table for compatibility				

Material and Adhesive Compatibility							
Material Code	Material Description (Compound No.)	Hot Melt Adhesives			High Performance Epoxy Adhesives		
		W1	W2	W3 (TACCOM approved)	R	U	
		High Temperature -55°C to 125°C	Standard -55°C to 70°C	Elastomeric -55°C to 125°C	Pre-Coat -75°C to 150°C	Two-Part -75°C to 155°C	
1	High-Performance Semi-Rigid Elastomer (2025)	●	●		●	Type U epoxy adhesive is compatible with all boot materials. Ordered separately, user-installed (779-001). Order boot with no adhesive lining.	
2	Zero Halogen Semi-Rigid Polyolefin (2010)	●	●		●		
3	General Purpose Flexible Polyolefin (2040)		●				
5	Viton Fluoroelastomer Blend (2050)	●		●	●		
6	High Performance Elastomer Alloy (2051)	●		●			
7	Semi-Rigid Polyolefin (2071)	●	●				
8	Low Outgassing Fluoropolymer Alloy (2008)	Material Type 8 not available with pre-coat adhesive. Use Type U two-part epoxy					
9	Low Temp Flexible Polyolefin (2013)		●				

NOTES

1. See **Modification Codes** listed in Section A for material color options available for **Type 1 (compound 2025)** material.
2. Recovered dimension apply to unrestricted recovery. Dimensions may differ than shown when boots are installed over assembly.



SERIES 77 Heat Shrink Transitions



770-014 1:3, Low Profile, Heat Shrink Transition Dimensions

1:3 Heat Shrink Transition: Dimensions

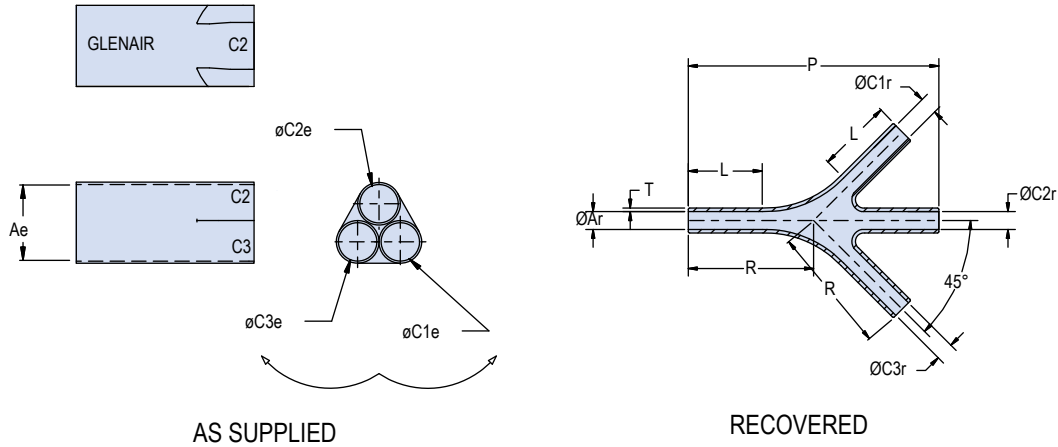

Dimensions											
Size	Glenair US Part Marking	TACOM Part Number (Ref)	GDLS (Ref)	Ae Min Dia	C1e, C2e, C3e Min Dia	Ar Max Dia	C1r, C2r, C3r Max Dia	T ±20%	P ±10%	L Ref	R Ref
09	09	12273163-1*	10652591-1	.78 (19.8)	.52 (13.2)	.26 (6.6)	.26 (6.6)	.04 (1.0)	3.38 (85.9)	1.00 (25.4)	1.69 (42.9)
10	10	12273163-2*	10652591-2	1.35 (34.3)	.81 (20.6)	.45 (11.4)	.45 (11.4)	.05 (1.3)	5.34 (135.6)	1.62 (41.1)	2.67 (67.8)
11	11	12273163-3*	10652591-3	2.37 (60.2)	1.42 (36.1)	.79 (20.1)	.79 (20.1)	.06 (1.5)	8.16 (207.3)	2.50 (63.5)	4.08 (103.6)
12	12	12273163-4*	10652591-4	3.93 (99.8)	2.16 (54.9)	1.31 (33.3)	1.31 (33.3)	.07 (1.8)	11.60 (294.6)	3.50 (88.9)	5.80 (147.3)
11-01	11-01		10652591-5	2.37 (60.2)	1.42 (36.1)	.79 (20.1)	.79 (20.1)	.06 (1.5)	5.34 (135.6)	1.09 (27.7)	2.67 (67.8)
12-01	12-01		10652591-6	3.93 (99.8)	2.16 (54.9)	1.31 (33.3)	1.31 (33.3)	.07 (1.8)	8.16 (207.3)	1.79 (45.5)	4.08 (103.6)

1:3 Heat Shrink Transition: Part Marking, Raised Lettering

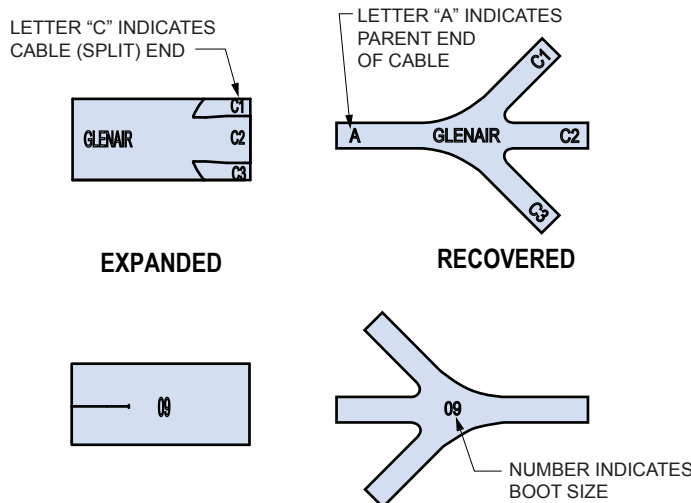



SERIES 77 Heat Shrink Transitions



770-015 1:4 Wide Body, Heat Shrink Transition How to Order



1:4 wide body, heat shrink transitions provide an easy to install and rugged cable routing solution. Transitional boots are available in eight material options with five adhesive choices. All adhesive lined and unlined shrink books are RoHS compliant. Transitional boots are water-tight when equipped with factory installed or user-installed adhesive. Choose boot size based on cable diameter.

How to Order						
Sample Part Number		770	-015	1	15	W1 -PP
Product Series	770 = Series 77 shrink boot					
Basic Number	015 = Basic number					
Material	See material and adhesives table					
Boot Size	14, 15, 16, 17, 18, 19; Based on cable diameter					
Adhesive Lined	W1, W2, W3, R, U, Omit for no adhesive; see material and adhesives table for compatibility					
Potting Port	PP = Potting Port Omit for none					

Material and Adhesive Compatibility							
Material Code	Material Description (Compound No.)	Hot Melt Adhesives			High Performance Epoxy Adhesives		
		W1	W2	W3 (TACCOM approved)	R	U	
		High Temperature -55°C to 125°C	Standard -55°C to 70°C	Elastomeric -55°C to 125°C	Pre-Coat -75°C to 150°C	Two-Part -75°C to 155°C	
1	High-Performance Semi-Rigid Elastomer (2025)	●	●		●	Type U epoxy adhesive is compatible with all boot materials. Ordered separately, user-installed (779-001). Order boot with no adhesive lining.	
2	Zero Halogen Semi-Rigid Polyolefin (2010)	●	●		●		
3	General Purpose Flexible Polyolefin (2040)		●				
5	Viton Fluoroelastomer Blend (2050)	●		●	●		
6	High Performance Elastomer Alloy (2051)	●		●			
7	Semi-Rigid Polyolefin (2071)	●	●				
8	Low Outgassing Fluoropolymer Alloy (2008)	Material Type 8 not available with pre-coat adhesive. Use Type U two-part epoxy					
9	Low Temp Flexible Polyolefin (2013)		●				

NOTES

1. See **Modification Codes** listed in Section A for material color options available for **Type 1 (compound 2025)** material.
2. Recovered dimension apply to unrestricted recovery. Dimensions may differ than shown when boots are installed over assembly.



SERIES 77 Heat Shrink Transitions



770-015 1:4 Wide Body, Heat Shrink Transition Dimensions

1:4 Heat Shrink Transition: Dimensions

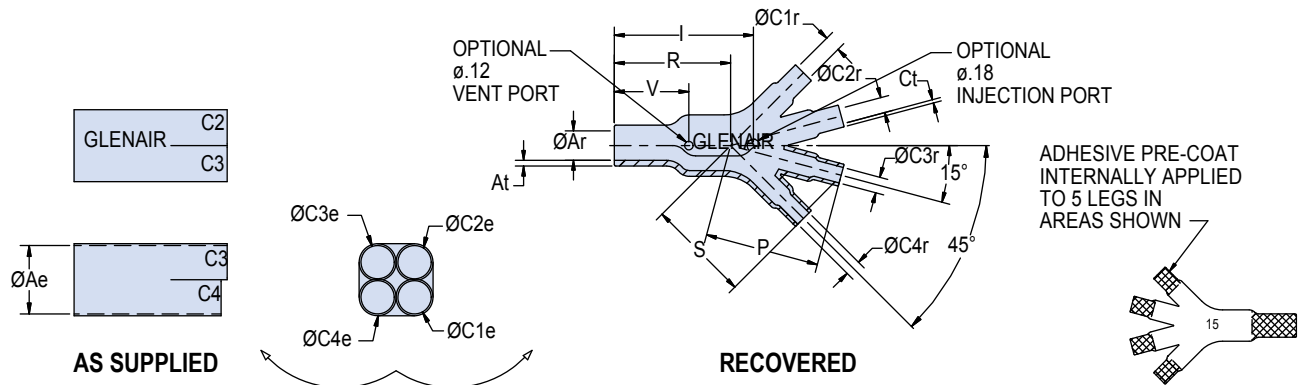

Dimensions												
Size	Glenair US Part Marking	Ae Min Dia	C1e, C2e C3e, C4e Min Dia	Ar Max Dia	C1r, C2r C3r, C4r Max Dia	At ±20%	Ct ±20%	R ±10%	P ±10%	S ±10%	V ±10%	I ±10%
14	14	.52(13.2)	.26(6.6)	.27(6.9)	.14(3.5)	.06(1.52)	.04(1.02)	1.51(38.4)	.95(24.1)	.95(24.1)	.79(20.0)	1.73(43.9)
15	15	.76(19.3)	.37(9.4)	.38(9.7)	.21(5.3)	.07(1.78)	.04(1.02)	1.42(36.1)	1.40(35.6)	1.26(32.0)	.91(23.1)	1.70(43.2)
16	16	.76(19.3)	.52(13.2)	.38(9.7)	.27(6.9)	.07(1.78)	.06(1.52)	1.42(36.1)	1.94(49.3)	1.77(45.0)	1.00(25.4)	1.99(50.5)
17	17	1.06(26.9)	.52(13.2)	.51(13.0)	.27(6.9)	.10(2.54)	.06(1.52)	2.04(51.8)	1.94(49.3)	1.77(45.0)	1.32(33.5)	2.59(65.8)
18	18	1.52(38.6)	.76(19.3)	.73(18.5)	.38(9.7)	.12(3.05)	.07(1.78)	2.95(74.9)	2.83(71.9)	2.57(65.3)	1.83(46.5)	3.75(95.3)
19	19	2.19(55.6)	1.06(26.9)	1.05(26.7)	.51(13.0)	.18(4.57)	.10(2.54)	4.27(108.5)	4.00(101.6)	3.64(92.5)	2.58(65.5)	5.32(135.1)

1:4 Heat Shrink Transition: Part Marking, Raised Lettering

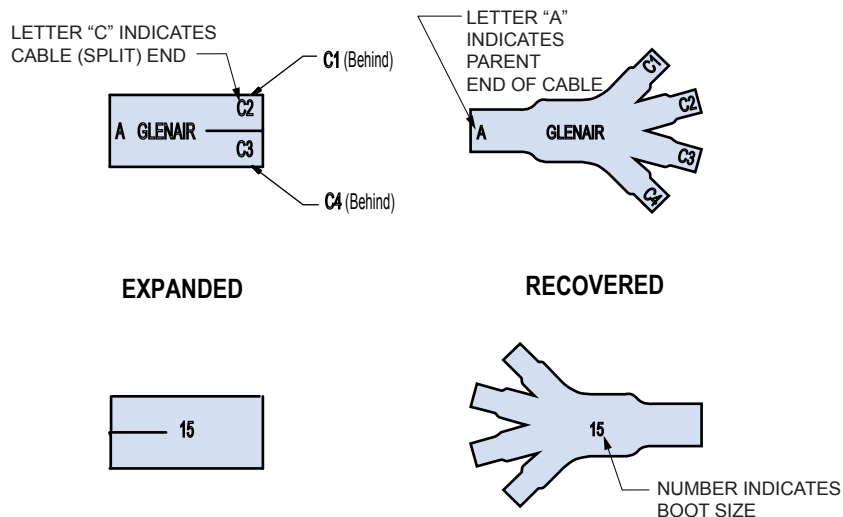



SERIES 77 Heat Shrink Transitions



770-011 Wide Body, Heat Shrink “Tee” Transition How to Order



Low profile “Tee” heat shrink transitions provide an easy to install and rugged cable routing solution. Transitional boots are available in eight material options with five adhesive choices. All Adhesive lined and unlined shrink books are RoHS compliant. Transitional boots are water-tight when equipped with factory installed or user-installed adhesive. Choose boot size based on cable diameter.

How to Order							
Sample Part Number	770	-011	T	1	03	W1	-PP
Product Series	770 = Series 77 shrink boot						
Basic Number	011 = Basic number						
Angular Function	T = “Tee” transition						
Material	See material and adhesives table						
Boot Size	01, 02, 03, 04 Based on cable diameter						
Adhesive Lined	W1, W2, W3, R, U, Omit for no adhesive; see material and adhesives table for compatibility						
Potting Ports	PP = Potting Ports Omit for none						

Material and Adhesive Compatibility							
Material Code	Material Description (Compound No.)	Hot Melt Adhesives			High Performance Epoxy Adhesives		
		W1	W2	W3 (TACCOM approved)	R	U	
		High Temperature -55°C to 125°C	Standard -55°C to 70°C	Elastomeric -55°C to 125°C	Pre-Coat -75°C to 150°C	Two-Part -75°C to 155°C	
1	High-Performance Semi-Rigid Elastomer (2025)	●	●		●	Type U epoxy adhesive is compatible with all boot materials. Ordered separately, user-installed (779-001). Order boot with no adhesive lining.	
2	Zero Halogen Semi-Rigid Polyolefin (2010)	●	●		●		
3	General Purpose Flexible Polyolefin (2040)		●				
5	Viton Fluoroelastomer Blend (2050)	●		●	●		
6	High Performance Elastomer Alloy (2051)	●		●			
7	Semi-Rigid Polyolefin (2071)	●	●				
8	Low Outgassing Fluoropolymer Alloy (2008)	Material Type 8 not available with pre-coat adhesive. Use Type U two-part epoxy					
9	Low Temp Flexible Polyolefin (2013)		●				

NOTES

1. See **Modification Codes** listed in Section A for material color options available for **Type 1 (compound 2025)** material.
2. Recovered dimension apply to unrestricted recovery. Dimensions may differ than shown when boots are installed over assembly.



SERIES 77
Heat Shrink Transitions



770-011 Wide Body, Heat Shrink “Tee” Transition
Dimensions

“Tee” Heat Shrink Transitions: Dimensions

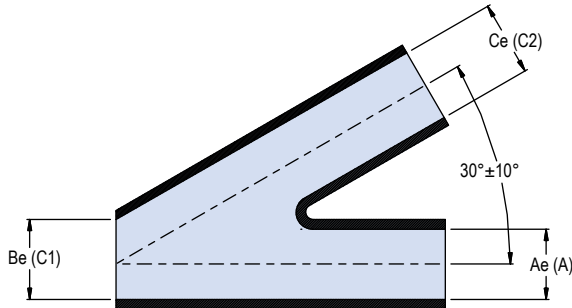

AS SUPPLIED

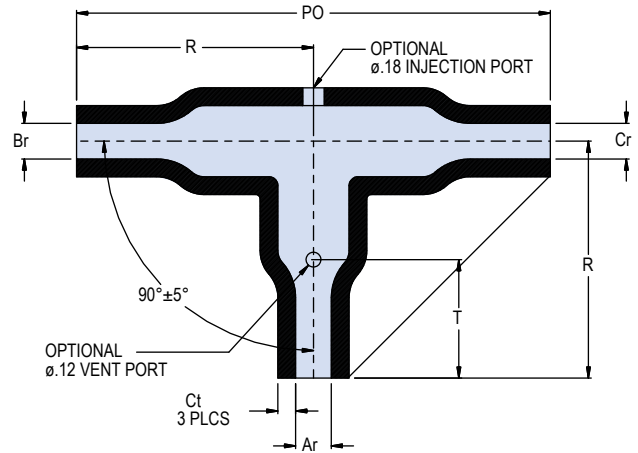

RECOVERED

Dimensions								
Size	Glenair US Part Marking	AS85049 /142 Figure 1	Ae, Be, Ce Min Dia	Ar, Br, Cr Max Dia	Ct ±20 %	PO ±10%	R ±10%	T ±10%
01	T01	01	.26 (6.6)	.14 (3.6)	.04 (1.02)	1.17 (29.7)	.59 (15.1)	N/A
02	T02	02	.52 (13.2)	.27 (6.9)	.06 (1.52)	2.31 (58.7)	1.16 (29.5)	.69 (17.5)
03	T03	03	1.06 (26.9)	.53 (13.5)	.09 (2.29)	4.73 (120.1)	2.37 (60.2)	1.40 (35.6)
04	T04	04	2.19 (55.6)	1.19 (30.2)	.12 (3.05)	9.70 (246.4)	4.85 (123.2)	2.79 (70.9)

“Tee” Heat Shrink Transitions: Part Marking, Raised Lettering

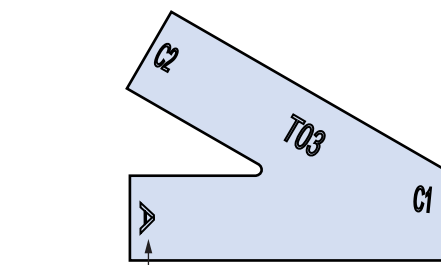

EXPANDED

LETTER “A” INDICATES PARENT CABLE END

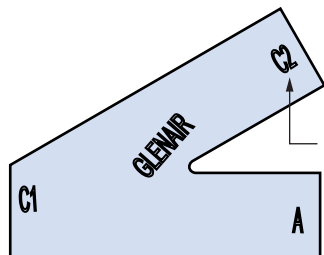

LETTER “C” INDICATES CHILD (SPLIT) END

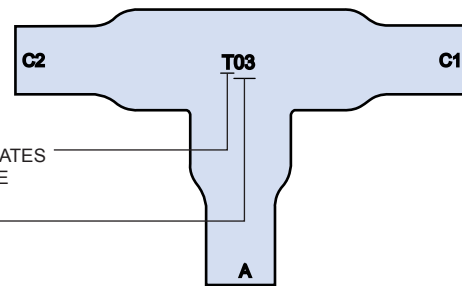

RECOVERED

LETTER “T” INDICATES TRANSITION TYPE

NUMBER “03” INDICATES SIZE

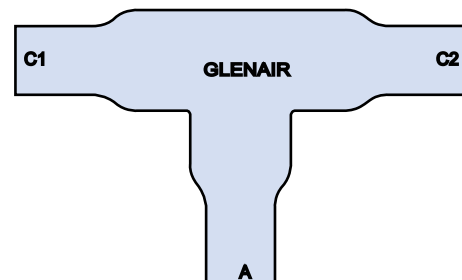



SERIES 77 Heat Shrink Transitions



770-012 Low Profile, Heat Shrink “Tee” Transition How to Order



Low profile heat shrink “Tee” transitions provide an easy to repair and rugged cable routing solution. Transitional boots are available in eight material options with five adhesive choices. All Adhesive lined and unlined shrink books are RoHS compliant. Transitional boots are water-tight when equipped with factory installed or user-installed adhesive. Choose boot size based on cable diameter.

How to Order						
Sample Part Number		770	-012	T	1	03 W1
Product Series	770 = Series 77 shrink boot					
Basic Number	012 = Basic number					
Angular Function	T = “Tee” transition					
Material	See material and adhesives table					
Boot Size	01, 02, 03, 04, 12 Based on cable diameter					
Adhesive Lined	W1, W2, W3, R, U, Omit for no adhesive; see material and adhesives table for compatibility					

Material and Adhesive Compatibility							
Material Code	Material Description (Compound No.)	Hot Melt Adhesives			High Performance Epoxy Adhesives		
		W1	W2	W3 (TACCOM approved)	R	U	
		High Temperature -55°C to 125°C	Standard -55°C to 70°C	Elastomeric -55°C to 125°C	Pre-Coat -75°C to 150°C	Two-Part -75°C to 155°C	
1	High-Performance Semi-Rigid Elastomer (2025)	●	●		●	Type U epoxy adhesive is compatible with all boot materials. Ordered separately, user-installed (779-001). Order boot with no adhesive lining.	
2	Zero Halogen Semi-Rigid Polyolefin (2010)	●	●		●		
3	General Purpose Flexible Polyolefin (2040)		●				
5	Viton Fluoroelastomer Blend (2050)	●		●	●		
6	High Performance Elastomer Alloy (2051)	●		●			
7	Semi-Rigid Polyolefin (2071)	●	●				
8	Low Outgassing Fluoropolymer Alloy (2008)	Material Type 8 not available with pre-coat adhesive. Use Type U two-part epoxy					
9	Low Temp Flexible Polyolefin (2013)		●				

NOTES

1. See **Modification Codes** listed in Section A for material color options available for **Type 1 (compound 2025)** material.
2. Recovered dimension apply to unrestricted recovery. Dimensions may differ than shown when boots are installed over assembly.



SERIES 77 Heat Shrink Transitions



770-012 Low Profile, Heat Shrink “Tee” Transition Dimensions

“Tee” Heat Shrink Transition: Dimensions

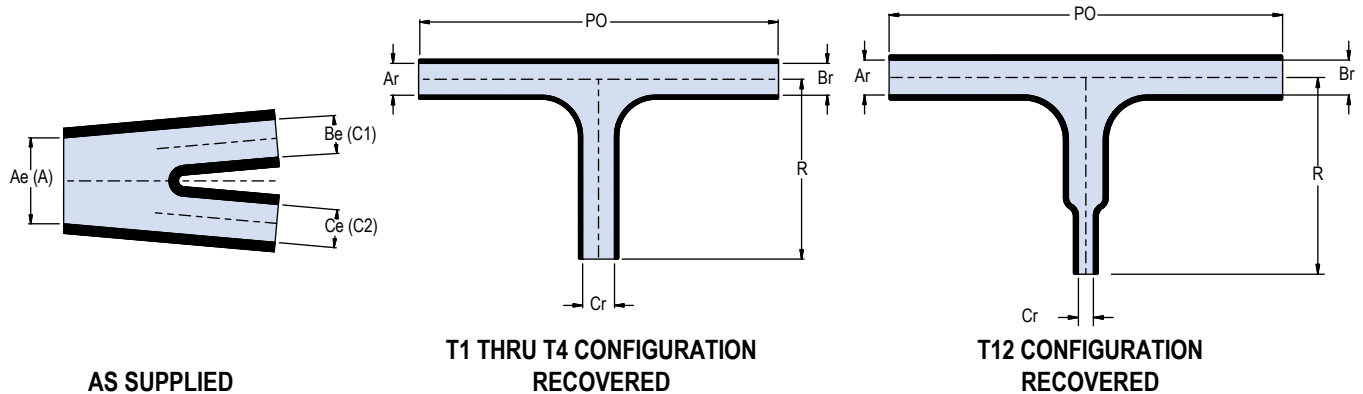

Dimensions									
Size	Glenair US Part Marking	Lockheed Martin JSF	Ae Dia Min Dia	Be Dia Min Dia	Ce Dia Min Dia	Ar, Br Max Dia	Cr Max Dia	PO ±10%	R Ref
01	T01	T1	.780 (19.8)	.520 (13.2)	.520 (13.2)	.260 (6.6)	.260 (6.6)	3.181 (80.8)	1.590 (40.4)
02	T02	T2	1.350 (34.3)	.900 (22.9)	.900 (22.9)	.450 (11.4)	.450 (11.4)	4.740 (120.4)	2.370 (60.2)
03	T03	T3	2.370 (60.2)	1.580 (40.1)	1.580 (40.1)	.791 (20.1)	.791 (20.1)	6.921 (175.8)	3.460 (87.9)
04	T04	T4	3.280 (83.3)	2.161 (54.9)	2.161 (54.9)	1.311 (33.3)	1.311 (33.3)	9.540 (242.3)	4.772 (121.2)
12	T12	GD/TACOM 12370946-1	1.350 (34.3)	.900 (22.9)	.500 (12.7)	.450 (11.4)	.200 (5.1)	4.740 (120.4)	2.370 (60.2)

“Tee” Heat Shrink Transition: Part Marking, Raised Lettering

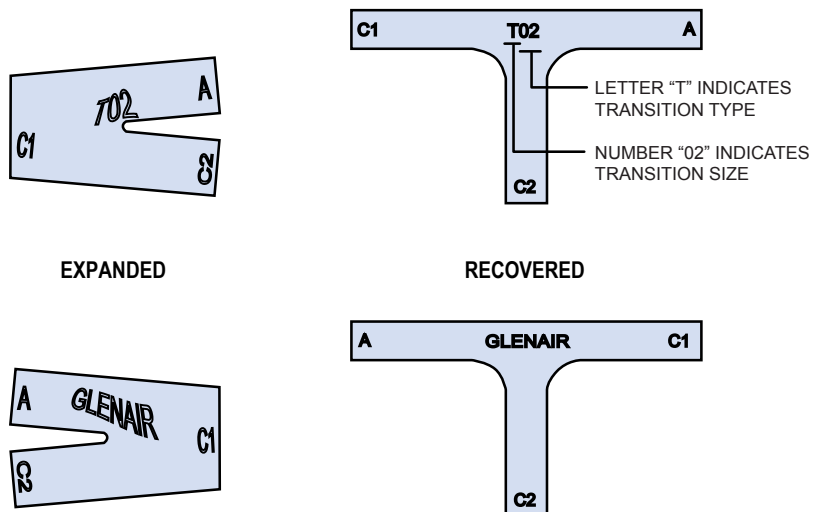



SERIES 77 Heat Shrink Transitions



770-023 1:2 Parallel, Heat Shrink Transition How to Order



1:2 parallel heat shrink transitions provide an easy to install and rugged cable routing solution. Transitional boots are available in eight material options with five adhesive choices. All adhesive lined and unlined shrink books are RoHS compliant. Transitional boots are water-tight when equipped with factory installed or user-installed adhesive. Choose boot size based on cable diameter.

How to Order					
Sample Part Number		770	-023	1	01 W1
Product Series	770 = Series 77 shrink boot				
Basic Number	023 = Basic number				
Material	See material and adhesives table				
Boot Size	01; Based on cable diameter				
Adhesive Lined	W1, W2, W3, R, U, Omit for no adhesive; see material and adhesives table for compatibility				

Material and Adhesive Compatibility						
Material Code	Material Description (Compound No.)	Hot Melt Adhesives			High Performance Epoxy Adhesives	
		W1	W2	W3 (TACCOM approved)	R	U
		High Temperature -55°C to 125°C	Standard -55°C to 70°C	Elastomeric -55°C to 125°C	Pre-Coat -75°C to 150°C	Two-Part -75°C to 155°C
1	High-Performance Semi-Rigid Elastomer (2025)	●	●		●	Type U epoxy adhesive is compatible with all boot materials. Ordered separately, user-installed (779-001). Order boot with no adhesive lining.
2	Zero Halogen Semi-Rigid Polyolefin (2010)	●	●		●	
3	General Purpose Flexible Polyolefin (2040)		●			
5	Viton Fluoroelastomer Blend (2050)	●		●	●	
6	High Performance Elastomer Alloy (2051)	●		●		
7	Semi-Rigid Polyolefin (2071)	●	●			
8	Low Outgassing Fluoropolymer Alloy (2008)	Material Type 8 not available with pre-coat adhesive. Use Type U two-part epoxy				
9	Low Temp Flexible Polyolefin (2013)		●			

NOTES

1. See **Modification Codes** listed in Section A for material color options available for **Type 1 (compound 2025)** material.
2. Recovered dimension apply to unrestricted recovery. Dimensions may differ than shown when boots are installed over assembly.



SERIES 77
Heat Shrink Transitions



770-023 1:2 Parallel, Heat Shrink Transition
Dimensions

1:2 Parallel Heat Shrink Transition: Dimensions

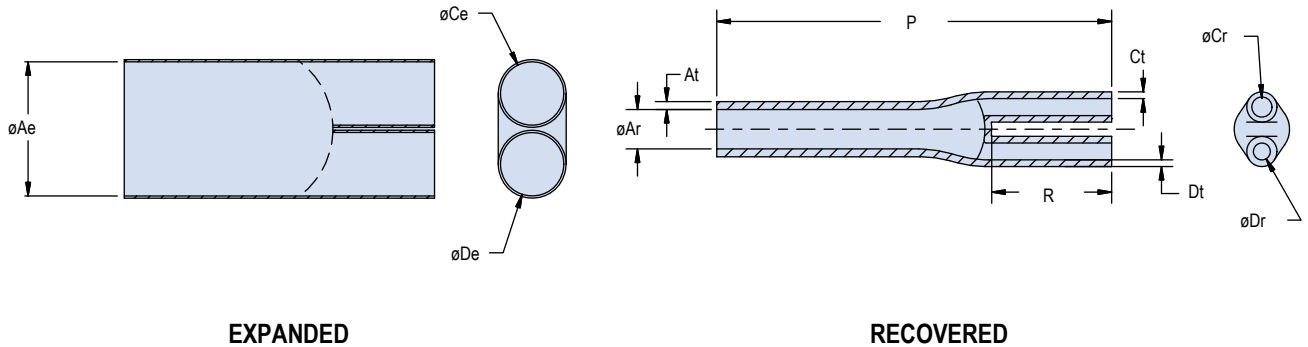

EXPANDED

RECOVERED

Dimensions									
Size	Glenair US Part Marking	Ae Min Dia	Ar Max Dia	At $\pm 10\%$	Ce, De Min Dia	Cr, Dr Max Dia	Ct, Dt $\pm 10\%$	P $\pm 10\%$	R $\pm 10\%$
01	P01	1.00 (25.4)	.370 (9.4)	.070 (1.78)	.600 (15.2)	.161 (1.41)	.060 (1.52)	3.500 (88.9)	1.100 (28.0)

1:2 Parallel Heat Shrink Transition: Part Marking, Raised Lettering

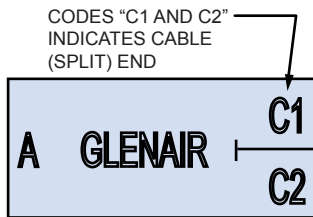

EXPANDED

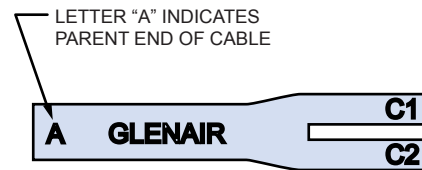

RECOVERED

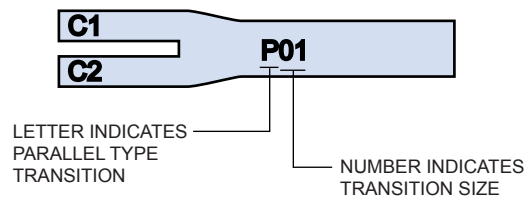
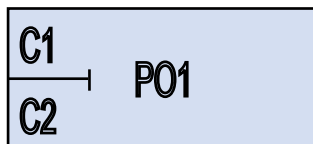



SERIES 77 Heat Shrink Transitions



770-035 45° Angled “Tee” Heat Shrink Transition How to Order



45° angle “Tee” transition heat shrink boots provide an easy to install and rugged cable routing solution. Transitional boots are available in eight material options with five adhesive choices. All adhesive lined and unlined shrink boots are RoHS compliant. Transitional boots are water-tight when equipped with factory installed or user-installed adhesive. Choose boot size based on cable diameter.

How to Order							
Sample Part Number	770	-035	T	1	02	W1	-PP
Product Series	770 = Series 77 shrink boot						
Basic Number	035 = Basic number						
Transition Shape	T = 45° Angle “Tee” transition						
Material	See material and adhesives table						
Boot Size	01, 02, 03; Based on cable diameter						
Adhesive Lined	W1, W2, W3, R, U, Omit for no adhesive; see material and adhesives table for compatibility						
Potting Ports	PP = Potting Ports; omit for none						

Material and Adhesive Compatibility							
Material Code	Material Description (Compound No.)	Hot Melt Adhesives			High Performance Epoxy Adhesives		
		W1	W2	W3 (TACCOM approved)	R	U	
		High Temperature -55°C to 125°C	Standard -55°C to 70°C	Elastomeric -55°C to 125°C	Pre-Coat -75°C to 150°C	Two-Part -75°C to 155°C	
1	High-Performance Semi-Rigid Elastomer (2025)	●	●		●	Type U epoxy adhesive is compatible with all boot materials. Ordered separately, user-installed (779-001). Order boot with no adhesive lining.	
2	Zero Halogen Semi-Rigid Polyolefin (2010)	●	●		●		
3	General Purpose Flexible Polyolefin (2040)		●				
5	Viton Fluoroelastomer Blend (2050)	●		●	●		
6	High Performance Elastomer Alloy (2051)	●		●			
7	Semi-Rigid Polyolefin (2071)	●	●				
8	Low Outgassing Fluoropolymer Alloy (2008)	Material Type 8 not available with pre-coat adhesive. Use Type U two-part epoxy					
9	Low Temp Flexible Polyolefin (2013)		●				

NOTES

1. See **Modification Codes** listed in Section A for material color options available for **Type 1 (compound 2025)** material.
2. Recovered dimension apply to unrestricted recovery. Dimensions may differ than shown when boots are installed over assembly.



SERIES 77
Heat Shrink Transitions



770-035 45° Angled "Tee" Heat Shrink Transition
Dimensions

45° Angled "Tee", Heat Shrink Transition: Dimensions

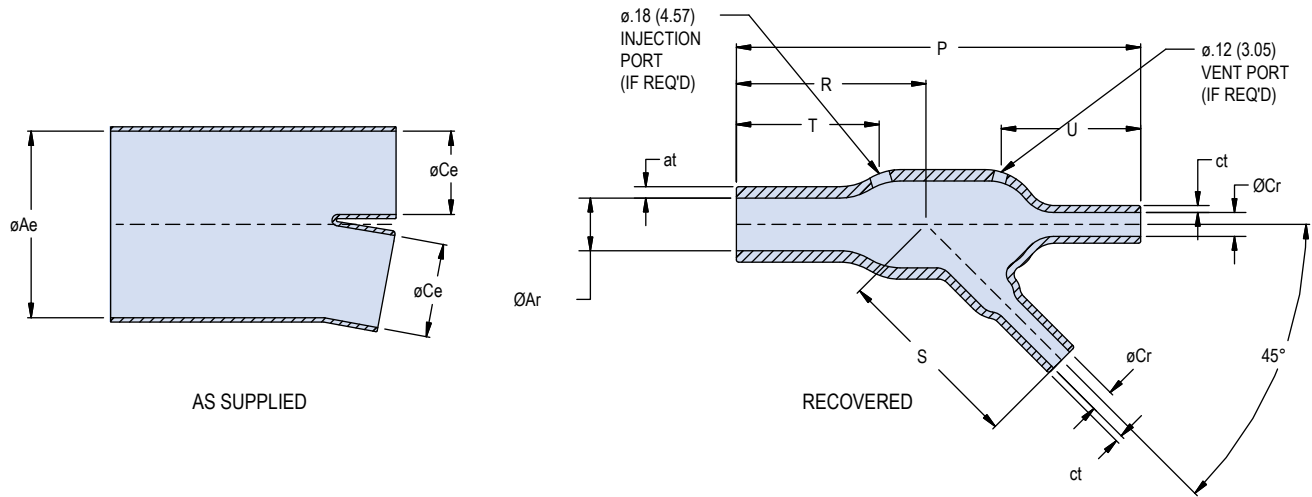

Dimensions												
Size	Glenair US Part Numbering	Ae Dia Min	Ce Dia Min	Ar Dia Max	at ±20%	Cr Dia Max	ct ±20%	P ±10%	R ±10%	S ±10%	T ±10%	U ±10%
01	T01	.52(13.2)	.26(6.6)	.24 (6.1)	.06 (1.52)	.12 (3.0)	.04 (1.02)	1.76 (44.7)	.90 (22.9)	.84 (21.3)	.70 (17.8)	.60 (15.2)
02	T02	1.06(26.9)	.52(13.2)	.49 (12.4)	.10 (2.54)	.24 (6.1)	.06 (1.52)	3.54 (89.9)	1.66 (42.2)	1.68 (42.7)	1.25 (31.8)	1.22 (31.0)
03	T03	2.19(55.6)	1.06(26.9)	1.00 (25.4)	.18 (4.57)	.49 (12.4)	.10 (2.54)	7.21 (183.1)	3.76 (95.5)	3.40 (86.4)	2.80 (71.1)	2.60 (66.0)

45° Angled "Tee", Heat Shrink Transition: Part Marking, Raised Lettering

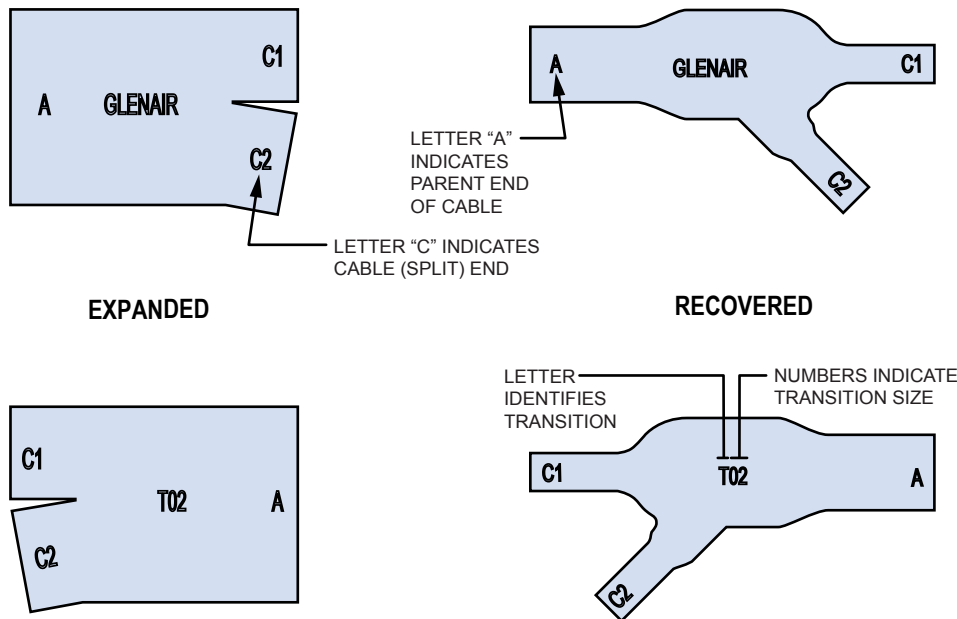



SERIES 77 Heat Shrink Transitions



770-036 30° Angled “Tee” Heat Shrink Transition How to Order



30° angle “Tee” transition heat shrink boots provide an easy to install and rugged cable routing solution. Transitional boots are available in eight material options with five adhesive choices. All adhesive lined and unlined shrink books are RoHS compliant. Transitional boots are water-tight when equipped with factory installed or user-installed adhesive. Choose boot size based on cable diameter.

How to Order							
Sample Part Number	770	-036	T	1	01	W1	-PP
Product Series	770 = Series 77 shrink boot						
Basic Number	036 = Basic number						
Transition Shape	T = 30° Angle “Tee” transition						
Material	See material and adhesives table						
Boot Size	01, 02, 03; Based on cable diameter						
Adhesive Lined	W1, W2, W3, R, U, Omit for no adhesive; see material and adhesives table for compatibility						
Potting Ports	PP = Potting Ports; omit for none						

Material and Adhesive Compatibility							
Material Code	Material Description (Compound No.)	Hot Melt Adhesives			High Performance Epoxy Adhesives		
		W1	W2	W3 (TACCOM approved)	R	U	
		High Temperature -55°C to 125°C	Standard -55°C to 70°C	Elastomeric -55°C to 125°C	Pre-Coat -75°C to 150°C	Two-Part -75°C to 155°C	
1	High-Performance Semi-Rigid Elastomer (2025)	●	●		●	Type U epoxy adhesive is compatible with all boot materials. Ordered separately, user-installed (779-001). Order boot with no adhesive lining.	
2	Zero Halogen Semi-Rigid Polyolefin (2010)	●	●		●		
3	General Purpose Flexible Polyolefin (2040)		●				
5	Viton Fluoroelastomer Blend (2050)	●		●	●		
6	High Performance Elastomer Alloy (2051)	●		●			
7	Semi-Rigid Polyolefin (2071)	●	●				
8	Low Outgassing Fluoropolymer Alloy (2008)	Material Type 8 not available with pre-coat adhesive. Use Type U two-part epoxy					
9	Low Temp Flexible Polyolefin (2013)		●				

NOTES

1. See **Modification Codes** listed in Section A for material color options available for **Type 1 (compound 2025)** material.
2. Recovered dimension apply to unrestricted recovery. Dimensions may differ than shown when boots are installed over assembly.



SERIES 77
Heat Shrink Transitions



770-036 30° Angled "Tee" Heat Shrink Transition
Dimensions

30° Angled "Tee", Heat Shrink Transition: Dimensions

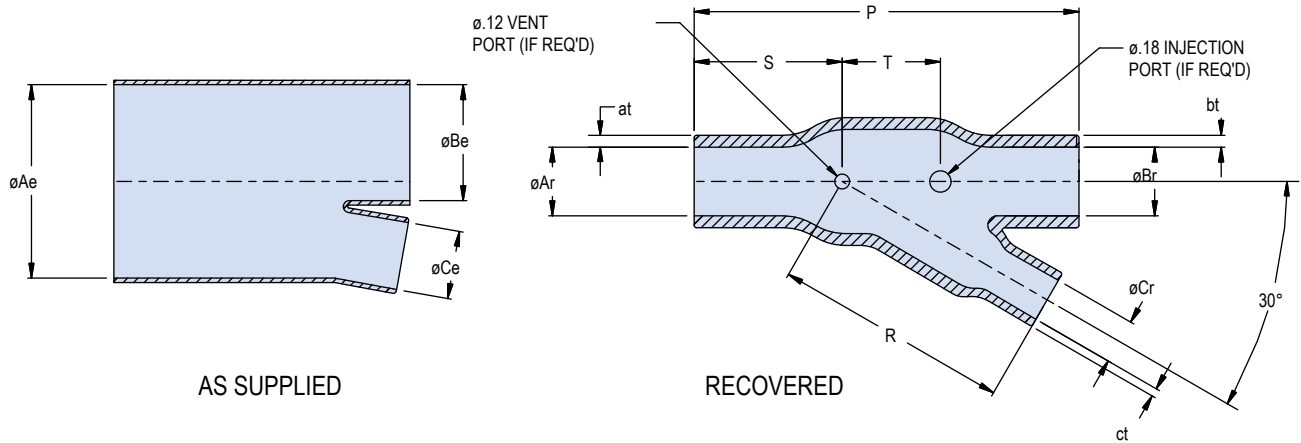

Dimensions											
Size	Glenair US Part Marking	Ae & Be Dia Min	Ce Dia Min	Ar & Br Dia Max	at & bt ±20%	Cr Dia Max	ct ±20%	R ±10%	P ±10%	S ±10%	T ±10%
01	T01	1.20 (30.5)	.80 (20.0)	.62 (15.7)	.10 (2.5)	.42 (10.7)	.07 (1.8)	2.00 (50.8)	3.25 (82.6)	1.25 (31.8)	.83 (21.1)
02	T02	1.40 (35.6)	.60 (15.5)	.72 (18.3)	.10 (2.5)	.34 (8.6)	.06 (1.5)	1.62 (41.1)	2.50 (63.5)	.75 (19.1)	.88 (22.4)
03	T03	1.40 (35.6)	.40 (10.2)	.74 (18.8)	.11 (2.8)	.21 (5.3)	.06 (1.5)	1.40 (35.6)	2.40 (61.0)	.75 (19.1)	.84 (21.3)

30° Angled "Tee", Heat Shrink Transition: Part Marking, Raised Lettering

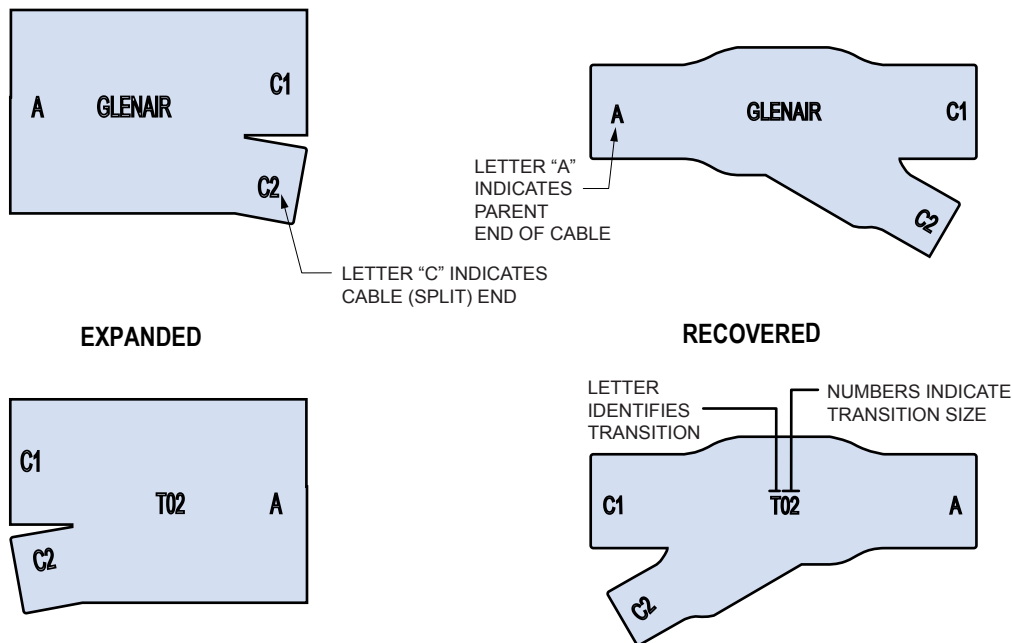



SERIES 77 Heat Shrink Transitions



770-037 45° Angled “Tee” Heat Shrink Transition How to Order



45° angle “Tee” transition heat shrink boots provide an easy to install and rugged cable routing solution. Transitional boots are available in eight material options with five adhesive choices. All adhesive lined and unlined shrink books are RoHS compliant. Transitional boots are water-tight when equipped with factory installed or user-installed adhesive. Choose boot size based on cable diameter.

How to Order							
Sample Part Number	770	-037	T	1	11	W1	-PP
Product Series	770 = Series 77 shrink boot						
Basic Number	037 = Basic number						
Transition Shape	T = 45° Angle “Tee” transition						
Material	See material and adhesives table						
Boot Size	10, 11, 12, 13, 14; Based on cable diameter						
Adhesive Lined	W1, W2, W3, R, U, Omit for no adhesive; see material and adhesives table for compatibility						
Potting Ports	PP = Potting Ports Omit for none						

Material and Adhesive Compatibility							
Material Code	Material Description (Compound No.)	Hot Melt Adhesives			High Performance Epoxy Adhesives		
		W1	W2	W3 (TACCOM approved)	R	U	
		High Temperature -55°C to 125°C	Standard -55°C to 70°C	Elastomeric -55°C to 125°C	Pre-Coat -75°C to 150°C	Two-Part -75°C to 155°C	
1	High-Performance Semi-Rigid Elastomer (2025)	●	●		●	Type U epoxy adhesive is compatible with all boot materials. Ordered separately, user-installed (779-001). Order boot with no adhesive lining.	
2	Zero Halogen Semi-Rigid Polyolefin (2010)	●	●		●		
3	General Purpose Flexible Polyolefin (2040)		●				
5	Viton Fluoroelastomer Blend (2050)	●		●	●		
6	High Performance Elastomer Alloy (2051)	●		●			
7	Semi-Rigid Polyolefin (2071)	●	●				
8	Low Outgassing Fluoropolymer Alloy (2008)	Material Type 8 not available with pre-coat adhesive. Use Type U two-part epoxy					
9	Low Temp Flexible Polyolefin (2013)		●				

NOTES

1. See **Modification Codes** listed in Section A for material color options available for **Type 1 (compound 2025)** material.
2. Recovered dimension apply to unrestricted recovery. Dimensions may differ than shown when boots are installed over assembly.



SERIES 77 Heat Shrink Transitions



770-037 45° Angled "Tee" Heat Shrink Transition Dimensions

45° Angled "Tee", Heat Shrink Transition: Dimensions

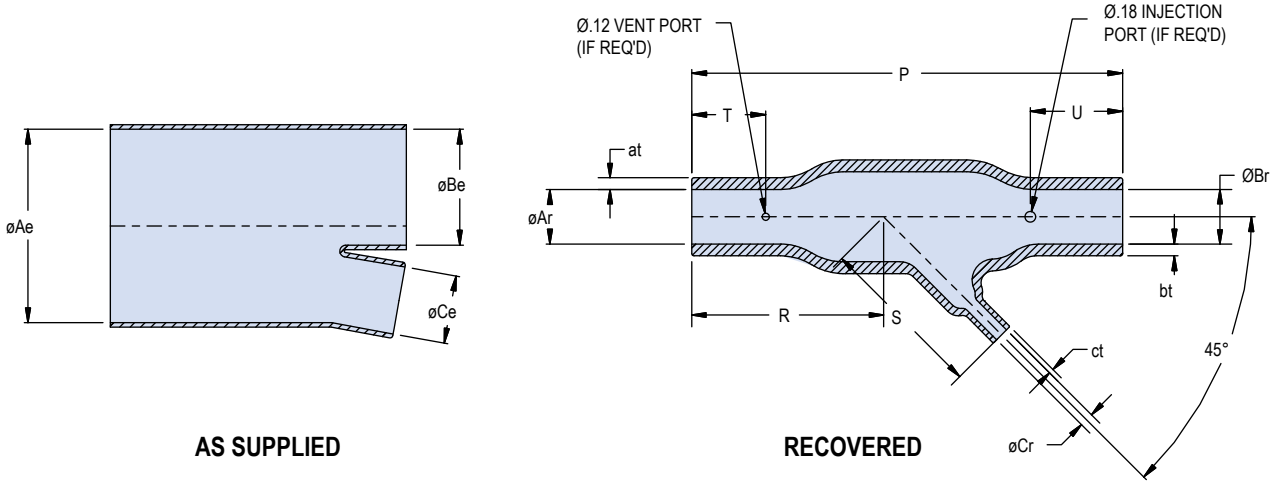

AS SUPPLIED

RECOVERED

Dimensions												
Size	Glenair US Part Marking	Ae & Be Dia Min	Ce Dia Min	Ar & Br Dia Max	at & bt $\pm 20\%$	Cr Dia Max	Ct $\pm 20\%$	R $\pm 10\%$	P $\pm 10\%$	S $\pm 10\%$	T $\pm 10\%$	U $\pm 10\%$
10	T10	.52 (13.2)	.26 (6.6)	.27 (6.9)	.06 (1.52)	.14 (3.6)	.04 (1.02)	.90 (22.9)	1.94 (49.3)	.92 (23.4)	.77 (19.6)	.77 (19.6)
11	T11	1.06 (26.9)	.26 (6.6)	.50 (12.7)	.10 (2.5)	.14 (3.6)	.04 (1.02)	1.62 (41.1)	3.64 (92.5)	1.41 (35.8)	1.25 (31.8)	1.56 (39.6)
12	T12	1.06 (26.9)	.52 (13.2)	.54 (13.7)	.10 (2.5)	.24 (6.1)	.06 (1.52)	2.75 (69.9)	5.70 (144.8)	2.11 (53.6)	2.00 (50.8)	2.00 (50.8)
13	T13	2.19 (55.6)	.52 (13.2)	1.06 (26.9)	.18 (4.57)	.27 (6.9)	.06 (1.52)	3.28 (83.3)	7.28 (184.9)	2.83 (71.9)	2.50 (63.5)	2.50 (63.5)
14	T14	2.19 (55.6)	1.06 (26.9)	1.06 (26.9)	.18 (4.57)	.54 (13.7)	.10 (2.54)	3.76 (95.5)	8.01 (203.5)	3.66 (93.0)	2.60 (66.0)	2.60 (66.0)

45° Angled "Tee", Heat Shrink Transition: Part Marking, Raised Lettering

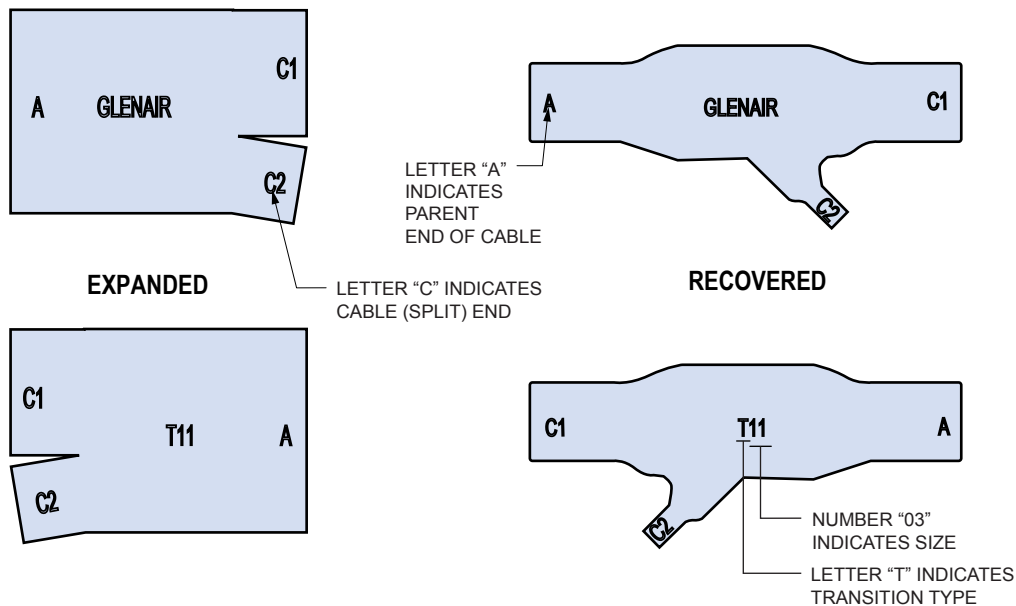



SERIES 77 Heat Shrink Transitions



770-038 30° Double, Angled “Tee” Heat Shrink Transition - How to Order



Double angled “Tee” transition heat shrink boots provide an easy to install and rugged cable routing solution. Transitional boots are available in eight material options with five adhesive choices. All adhesive lined and unlined shrink boots are RoHS compliant. Transitional boots are water-tight when equipped with factory installed or user-installed adhesive. Choose boot size based on cable diameter.

How to Order							
Sample Part Number	770	-038	T	1	01	W1	-PP
Product Series	770 = Series 77 shrink boot						
Basic Number	038 = Basic number						
Transition Shape	T = 30° Angle “Tee” transition						
Material	See material and adhesives table						
Boot Size	01; Based on cable diameter						
Adhesive Lined	W1, W2, W3, R, U, Omit for no adhesive; see material and adhesives table for compatibility						
Potting Ports	PP = Potting Ports; omit for none						

Material and Adhesive Compatibility							
Material Code	Material Description (Compound No.)	Hot Melt Adhesives			High Performance Epoxy Adhesives		
		W1	W2	W3 (TACCOM approved)	R	U	
		High Temperature -55°C to 125°C	Standard -55°C to 70°C	Elastomeric -55°C to 125°C	Pre-Coat -75°C to 150°C	Two-Part -75°C to 155°C	
1	High-Performance Semi-Rigid Elastomer (2025)	●	●		●	Type U epoxy adhesive is compatible with all boot materials. Ordered separately, user-installed (779-001). Order boot with no adhesive lining.	
2	Zero Halogen Semi-Rigid Polyolefin (2010)	●	●		●		
3	General Purpose Flexible Polyolefin (2040)		●				
5	Viton Fluoroelastomer Blend (2050)	●		●	●		
6	High Performance Elastomer Alloy (2051)	●		●			
7	Semi-Rigid Polyolefin (2071)	●	●				
8	Low Outgassing Fluoropolymer Alloy (2008)	Material Type 8 not available with pre-coat adhesive. Use Type U two-part epoxy					
9	Low Temp Flexible Polyolefin (2013)		●				

NOTES

1. See **Modification Codes** listed in Section A for material color options available for **Type 1 (compound 2025)** material.
2. Recovered dimension apply to unrestricted recovery. Dimensions may differ than shown when boots are installed over assembly.



SERIES 77
Heat Shrink Transitions



770-038 30° Double, Angled “Tee” Heat Shrink Transition - Dimensions

30° Double Angled “Tee” Heat Shrink Transition: Dimensions

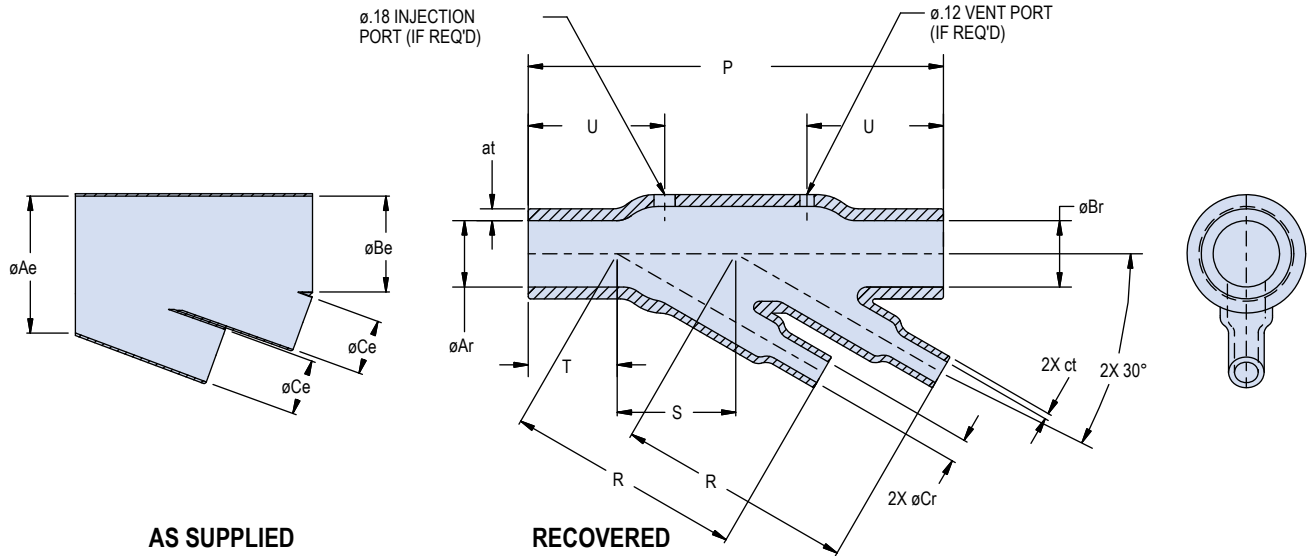

Dimensions												
Size	Glenair US Part Marking	Ae & Be Dia Min	Ce Dia Min	Ar & Br Dia Max	at & bt $\pm 20\%$	Cr Dia Max	ct $\pm 20\%$	R $\pm 10\%$	P $\pm 10\%$	S $\pm 10\%$	T $\pm 10\%$	U $\pm 10\%$
01	T01	1.20 (30.5)	.50 (12.7)	.60 (15.2)	.10 (2.54)	.25 (6.3)	.05 (1.27)	2.00 (50.8)	3.50 (88.9)	1.00 (25.4)	.75 (19.1)	1.15 (29.2)

30° Double Angled “Tee” Heat Shrink Transition: Part Marking, Raised Lettering

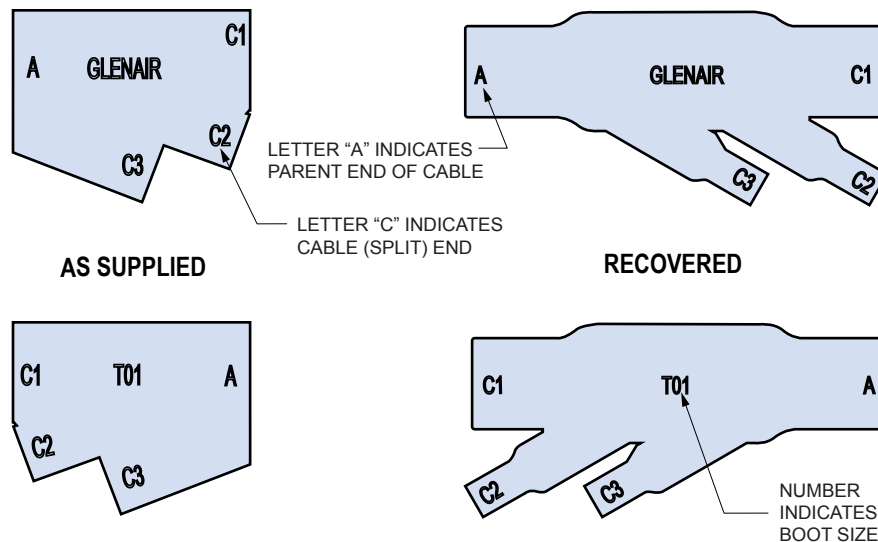

SERIES 77
SHRINK BOOT
ADAPTERS

SHRINK BOOT ADAPTERS

Light weight cable sealing solution



Choose from the industry's largest offering of shrink boot adapters. Adapters allow connectors with threaded backshell accommodation to accept a smaller, lighter shrink boot cable sealing solution. Available with EMI/RFI shield termination with a variety of termination options including lamp-base thread, factory crimped and tinned shield sock or banding platform for use with Band-Master ATS shield termination bands. Adapters available in both metal or composite versions with popular finish options to fit your application.



Glenair, Inc.
1211 Air Way
Glendale, CA 91201-2497
818-247-6000
sales@glenair.com
www.glenair.com





SERIES 77
Shrink Boot Adapters
Product Selection Guide



Metal Shrink Boot Adapters

Glenair manufactures several series of rugged aluminum, shrink boot adapters for shielded or unshielded cable.

G-2



Series 310
 Shrink boot adapters for unshielded cables. Available with rotatable or direct coupling

G-8



Series 311
 Lamp-base thread shrink boot adapters provide easy termination of EMI/RFI shielding. Braided shielding is captivated under threaded nut.

G-12



Series 319
 Shield sock shrink boot adapters are available with rotatable or self-locking coupling nut and factory-crimped and tinned copper braid.

G-14



Series 440
 Shrink boot adapters for shielded cable provide a banding platform for the attachment of cable braid using BAND-IT® bands.

G-18



MIL-SPEC Adapters
 Straight shrink boot adapters are available for all types of cylindrical connectors.

G-20



Series 63
 Bulkhead feed-through fittings

G-26

Composite Thermoplastic Shrink Boot Adapters

Glenair manufactures several series of lightweight, corrosion-resistant composite shrink boot adapters for shielded or unshielded cable.

G-258



Series 310
 Shrink boot adapters for unshielded cables. Available with rotatable or direct coupling

G-30



Series 380
 Shrink boot adapters for shielded cables. Rotatable coupling

G-32



Series 440
 Ultra low profile EMI/RFI adapters. Available with self locking, rotatable coupling nut, banding porch and boot groove

G-33



Series 447
 Ultra low profile EMI/RFI shrink boot adapter. Available with self locking, rotatable coupling nut, banding porch and boot groove

G-35

For a complete line-up of metal shrink boot adapters see the Circular Connector Adapters and Accessories Catalog or for composite adapters see the Composite Thermoplastic Adapters and Accessories Catalog.

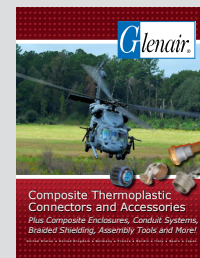



METAL AND COMPOSITE Shrink Boot Adapters

Choose from the industry's largest offering of metal or composite shrink boot adapters. Light-weight and simple to install adapters accommodate shrink boots and work with shielded and unshielded cables. Shrink boots provide simple and cost effective environmental protection from dust and debris. As heat is applied to the boot it will begin to return to its original size and the lipped edge of the boot will lock around a recessed groove at the rear of the adapter. Adhesives create a water tight seal around the adapter and cable while the boot also provides mechanical strain relief. Cable braid termination platforms support band termination as-well-as lamp-base threads, magna-forming or Tinel® locking systems for EMI/RFI protection. All adapters work with lipped-type shrink boots.

Additional information can be found in the Glenair Circular Connector Adapters and Accessories catalog. Comprehensive information on composite adapters can be found in our Composite Thermoplastic Connectors and Accessories catalog. For additional details on mil-spec versions, refer to Mil-Spec Adapters and Connector Accessories catalog.



- Metal and Composite
- Rotatable Self Locking and Direct Coupling Styles
- Standard and Low Profile Designs
- Straight, 45° and 90° configurations



SERIES 77
Metal Shrink Boot Adapters
Adapter Reference Guide
Material Selection and Finish



Connector Designator Reference		
Designator	Specification	Series
A	MIL-DTL-5015	MS3400
	MIL-DTL-26482	2
	AS81703	3
	MIL-DTL-83723	I & III
	40M39569	
	DEF 5326-3	
	EN 2997, 3646	
	ESC 10, 11	
	LN 29504	
	NFC93422	HE302
PAN 6432-1, -2		
PATT 602		
B	MIL-DTL-5015	MS3100
C	MIL-C-22992	MS173XX
D	MIL-DTL-26482	I
E	MIL-DTL-26500 Aluminum	
F	MIL-DTL-38999	I & II
	40M38277	
	PAN 6433-1	
	PATT 614	
	PATT 616	
NFC93422	HE308, 9	
G	MIL-C-28840	
H	MIL-DTL-38999	III & IV
	EN3645	
J	MIL-C-81511 VG95329	1,2,3&4
K	MIL-DTL-83723	II
L	EN3372	
	JN 1003	
	LN 29729	
	NFC93422	HE306
	PAN 6433-2	
	PATT 615	
S	VG 96912	
	PATT 105	
	PATT 603	
	PATT 608	

The following standard materials are used for the majority of Glenair adapters and connector accessories. However, adapter components are not limited to those items listed, but are representative of the elements used in Glenair's general accessory products. Contact Glenair for applicable specifications on items not listed below.

Standard Materials - Adapters and Accessories		
Component	Material	Specification
Machined components: such as adapter bodies, fabricated elbows, protective covers, rotatable couplers, dummy stowage receptacles, lock nuts, G-spring support rings, EMI ground rings, grommet followers, etc.	Aluminum	QQ-A-200, 225 ASTMB211, 221
Die cast components: such as angular adapters, strain relief adapters, strain relief bodies, strain relief saddles, special EMI ground rings, etc.	Aluminum	ASTM B179 ASTM B85
Adapters or strain reliefs: available in optional corrosion resisting steel; and hardware: such as screws, washers, rivets, wire rope, sash chain, band straps, etc.	Corrosion Resisting Steel	ASTM A581, 582 ASTM A276
Elastomeric seals: such as O-rings, cable jacket seals, grommets, etc.	Silicone	ZZ-R-765
Anti-friction and thrust washers	PTFE	
Anti-rotation device	Corrosion Resistant Material	

Metal adapter Plating Codes	
Sym	Material and Finish
B	Aluminum, Cadmium Plated, Olive Drab
C*	Aluminum, Black Anodize
M	Aluminum, Electroless Nickel
MT	Aluminum, Nickel-PTFE
NF	Aluminum, Cadmium, Olive Drab Over Electroless Nickel
Z1	Stainless Steel, Passivated
ZR	Aluminum, Zinc-nickel, black

*Non-Conductive finish — not suitable for EMI or grounding applications.

NOTES

On all length callouts, tolerance is $\pm .060$ unless otherwise specified.

Unless otherwise specified, the following other dimensional tolerances will apply:

.xx = $\pm .03$ (0.8) Lengths = $\pm .060$ (1.52)

.xxx = $\pm .015$ (0.4) Angles = $\pm 5^\circ$





SERIES 77 Composite Shrink Boot Adapters



Adapter Reference Guide

Table I - Connector Designator Interface Dimensions

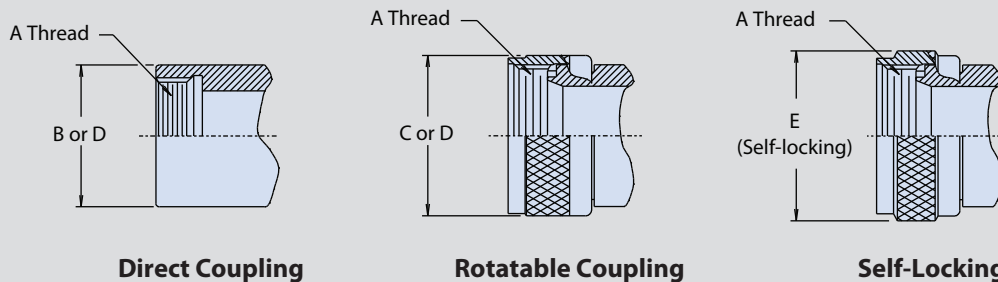

Table I - Adapter Interface Dimensions

Connector Designator**															A Thread*	B DIA MAX	C DIA MAX	D DIA MAX	E DIA MAX
A	C*	D	E	F	G	H	J	K	L	S	REFERENCE								
--	--	08	08	08 [9]	--	--	--	08	08	08	7/16 - 28 UNEF	.590 (15.)	.650 (16.5)	.770 (19.6)	.690 (17.5)				
--	--	--	--	--	--	09 [A]	--	--	--	--	M12 x 1 - 6H	.650 (16.5)	.770 (19.6)	--	.940 (24.8)				
08	--	--	--	--	--	--	--	--	--	--	1/2 - 20 UNF	.650 (16.5)	.650 (16.5)	--	.690 (17.5)				
--	--	--	--	--	--	--	08 [A]	10	--	--	1/2 - 28 UNEF	.650 (16.5)	.770 (19.6)	.770 (19.6)	--				
03	--	10	10	10 [11]	--	--	--	11	10	10	9/16 - 24 UNEF	.720 (18.3)	.770 (19.6)	.890 (22.6)	.820 (20.8)				
--	--	--	--	--	--	11 [B]	--	--	--	--	M15 x 1 - 6H	.770 (19.6)	.820 (20.8)	--	1.060 (26.9)				
10	--	--	--	--	--	--	--	12 [13]	--	--	5/8 - 24 UNEF	.770 (19.6)	.770 (19.6)	.890 (22.6)	.820 (20.8)				
--	--	--	--	--	--	--	10 [B]	--	--	--	5/8 - 28 UN	.770 (19.6)	.890 (22.6)	--	--				
--	--	12	--	12 [13]	--	--	--	--	12	12	11/16 - 24 UNEF	.840 (21.3)	.890 (22.6)	1.020 (25.9)	.940 (23.8)				
--	--	--	--	--	--	13 [C]	--	--	--	--	M18 x 1 - 6H	.890 (22.6)	.940 (23.9)	--	1.170 (29.7)				
[7]	12	--	12	--	11 [A]	--	--	14 [15]	--	--	3/4 - 20 UNEF	.970 (24.6)	.940 (23.9)	1.020 (25.9)	.940 (23.8)				
--	--	14	14	14 [15]	--	--	--	--	14	14	13/16 - 20 UNEF	.970 (24.6)	1.020 (29.2)	1.150 (29.2)	1.060 (26.9)				
--	--	--	--	--	--	15 [D]	--	--	--	--	M22 x 1 - 6H	1.030 (26.2)	1.070 (26.2)	--	1.290 (32.7)				
[12]	14	--	--	--	13 [B]	--	--	16 [17]	--	--	7/8 - 20 UNEF	1.090 (27.7)	1.020 (25.9)	1.150 (29.2)	1.060 (26.9)				
--	--	--	--	--	--	--	14 [D]	--	--	--	7/8 - 28 UN	1.030 (26.2)	1.150 (29.2)	--	--				
--	--	16	16	16 [17]	--	--	--	--	16	16	15/16 - 20 UNEF	1.090 (27.7)	1.150 (29.2)	1.260 (32.0)	1.170 (29.7)				
--	--	--	--	--	--	17 [E]	--	--	--	--	M25 x 1 - 6H	1.150 (29.2)	1.210 (30.7)	--	1.420 (36.1)				
[19]	16	--	--	--	15 [C]	--	--	18	--	--	1 - 20 UNEF	1.220 (29.2)	1.210 (30.7)	1.230 (31.2)	1.170 (29.7)				
--	--	--	--	--	--	--	16 [E]	--	--	--	1 - 28 UN	1.150 (29.2)	1.360 (34.5)	--	--				
[27]	--	18	18	18 [19]	--	--	--	--	18	18	11/16 - 18 UNEF	1.220 (31.0)	1.230 (31.2)	1.400 (35.6)	1.290 (32.7)				
--	--	--	--	--	--	19 [F]	--	--	--	--	M28 x 1 - 6H	1.280 (32.5)	1.360 (34.5)	--	1.540 (39.1)				
--	18	--	--	--	17 [D]	--	--	20	--	--	11/8 - 18 UNEF	1.340 (34.0)	1.360 (34.5)	1.360 (34.5)	--				
--	--	--	--	--	--	--	18 [F]	--	--	--	11/8 - 28 UN	1.280 (32.5)	1.480 (37.6)	--	--				
[37]	--	20	20	20 [21]	--	--	--	--	20	20	13/16 - 18 UNEF	1.340 (34.0)	1.360 (34.5)	1.530 (38.9)	1.420 (36.0)				
--	--	--	--	--	--	21 [G]	--	--	--	--	M31 x 1 - 6H	1.410 (35.8)	1.480 (37.6)	--	1.670 (42.4)				

* Code C, MIL-C-22992, Left-Hand Thread. **Connector designations depicted thus [] are for reference only and are not to be used in part number development.



SERIES 77 Composite Shrink Boot Adapters



Adapter Reference Guide

Table I - Connector Designator Interface Dimensions

Table I - Adapter Interface Dimensions															
Connector Designator**											A Thread*				
A	C*	D	E	F	G	H	J	K	L	S	REFERENCE	B DIA MAX	C DIA MAX	D DIA MAX	E DIA MAX
--	20	--	--	--	19 [E]	--	--	22	--	--	11/4 - 18 UNEF	1.470 (37.3)	1.530 (38.9)	1.480 (37.6)	--
--	--	--	--	--	--	--	20 [G]	--	--	--	11.4 - 28 UN	1.410 (35.8)	1.600 (40.6)	--	--
22	--	22	22	22 [23]	--	--	--	--	22	22	15/16 - 18 UNEF	1.470 (37.3)	1.480 (37.6)	1.600 (40.6)	1.540 (39.1)
--	--	--	--	--	--	23 [H]	--	--	--	--	M34 x 1 - 6H	1.530 (38.9)	1.600 (40.6)	--	2.010 (51.1)
--	22	--	--	--	--	--	--	24	--	--	13/8 - 18 UNEF	1.590 (40.4)	--	1.600 (40.6)	--
--	--	--	--	--	--	--	22 [H]	--	--	--	13/8 - 28 UN	1.530 (38.9)	1.730 (43.9)	--	--
24	--	24	24	24 [25]	23 [F]	--	--	--	24	24	17/16 - 18 UNEF	1.590 (40.4)	1.730 (43.9)	1.940 (49.3)	1.660 (42.2)
--	--	--	--	--	--	25 [J]	--	--	--	--	M37 x 1 - 6H	1.660 (42.2)	1.700 (43.2)	--	2.120 (53.8)
61	--	--	--	--	--	--	--	--	--	--	11/2 - 18 UNEF	1.660 (42.2)	1.670 (42.4)	--	--
--	--	--	--	--	--	--	24 [J]	--	--	--	11/2 - 28 UN	1.660 (42.2)	1.940 (49.3)	--	--
--	--	--	--	--	25 [G]	--	--	--	--	--	19/16 - UNEF	--	1.820 (46.2)	--	--
--	24	--	--	--	--	--	--	28	--	--	15/8 - UNEF	1.840 (46.7)	--	1.940 (49.3)	--
28	--	--	--	--	--	--	--	--	--	--	13/4 - 18 UNS	1.970 (50.0)	1.970 (50.0)	--	2.010 (51.1)
--	28	--	--	--	29 [H]	--	--	32	--	--	17/8 - 16 UN	2.090 (53.1)	2.190 (55.6)	2.190 (55.6)	--
32	--	--	--	--	--	--	--	--	--	--	2 - 18 UNS	2.280 (57.9)	2.220 (56.4)	--	2.260 (57.4)
--	32	--	--	--	33 [J]	--	--	--	--	--	2 1/16 - 16 UNS	2.340 (59.4)	2.440 (62.0)	2.440 (62.0)	--
--	--	--	--	--	--	--	--	36	--	--	2 1/8 - 16 UN	2.340 (59.4)	--	2.440 (62.0)	--
36	--	--	--	--	--	--	--	--	--	--	2 1/4 - 16 UN	2.530 (64.3)	2.47 (62.7)	--	2.530 (64.3)
--	36	--	--	--	--	--	--	--	--	--	2 5/16 - 16 UNS	2.590 (65.8)	--	2.690 (68.3)	--
--	--	--	--	--	--	--	--	40	--	--	2 3/8 - 16 UN	2.590 (65.8)	--	2.690 (68.3)	--
40	--	--	--	--	--	--	--	--	--	--	2 1/2 - 16 UN	2.780 (70.6)	2.720 (69.1)	--	3.040 (77.2)
--	40	--	--	--	--	--	--	--	--	--	2 5/8 - 16 UN	2.910 (73.9)	--	2.930 (74.4)	--
44	--	--	--	--	--	--	--	--	--	--	2 3/4 - 16 UN	3.030 (77.0)	2.970 (75.4)	--	--
--	44	--	--	--	--	--	--	--	--	--	2 7/8 - 16 UN	3.160 (80.3)	--	--	--
48	--	--	--	--	--	--	--	--	--	--	3 - 16 UN	3.220 (81.8)	3.220 (81.8)	--	--
--	48	--	--	--	--	--	--	--	--	--	3 1/16 - 16 UN	3.410 (86.6)	--	--	--

* Code C, MIL-C-22992, Left-Hand Thread. **Connector designations depicted thus [] are for reference only and are not to be used in part number development.

BODY STRAP

Glenair offers an optional stainless steel body strap for attaching protective covers as illustrated. To specify body strap, add suffix letter C to the end of the part number. For example 360A5001M1610M6C.

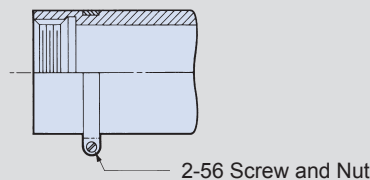

G



SERIES 77

Metal Shrink Boot Adapters



Adapter Reference Guide - MIL-DTL-5015 Connector Designator "B" (MS3100) Interface Dimensions

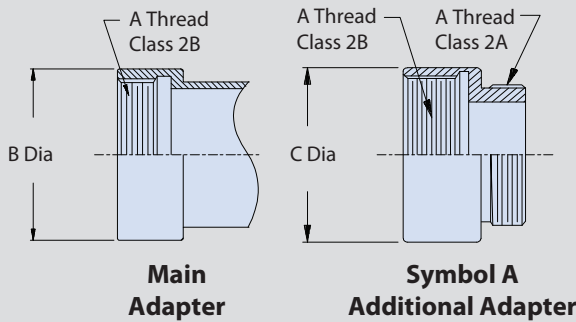

NOTES:

1. If the specific manufacturer is not known, order symbol A and corresponding dash number, for MS universal fit.
2. Symbol A mates with all connectors for each shell size.
3. Additional transition adapters may be supplied with symbol A for each shell size, as noted.

MS3100 Series Manufacturer Designations

Dash Number	Shell Size	Connector Manufacturer Desig	See Note 1	A Thread Class 2B	B Dia Max	C Dia Max
01	8S	A	1	7/16-28 UNEF	.656 (16.7)	.625 (15.9)
02	8S	J, M, N,	2	7/16-28 UNEF	.656 (16.7)	.625 (15.9)
03	8S	L	3	3/8-32 UNEF	.607 (15.4)	.562 (14.3)
04	8S	H	3	7/16-27 UNS	.656 (16.7)	.625 (15.9)
05	10S	A	1	1/2-28 UNEF	.724 (18.4)	.687 (17.4)
06	10S	H, J, L, N	2	1/2-28 UNEF	.724 (18.4)	.687 (17.4)
07	10S	M	3	9/16-24 UNEF	.724 (18.4)	.687 (17.4)
08	10SL	A	1	9/16-24 UNEF	.724 (18.4)	.687 (17.4)
09	10SL	M, N	2	9/16-24 UNEF	.724 (18.4)	.687 (17.4)
10	10SL	H, J, L	3	5/8-24 UNEF	.848 (21.5)	.812 (20.6)
11	12, 12S	A	1	5/8-24 UNEF	.848 (21.5)	.812 (20.6)
12	12, 12S	L, N	2	5/8-24 UNEF	.848 (21.5)	.812 (20.6)
13	12, 12S	H, J, M	3	11/16-24 UNEF	.848 (21.5)	.812 (20.6)
14	12SL, 14, 14S	A	2	3/4-20 UNEF	.974 (24.7)	.937 (23.8)
15	16, 16S	A	2	7/8-20 UNEF	1.102 (28.0)	1.062 (27.0)
16	18	A	2	1-20 UNEF	1.220 (31.0)	1.187 (30.1)
17	20	A	1	1 1/8-18 UNEF	1.343 (34.1)	1.312 (34.1)
18	20	H, L, M, N	2	1 1/8-18 UNEF	1.343 (34.1)	1.312 (33.3)
19	20	J	3	1 1/8-24 UNS	1.343 (34.1)	1.312 (33.3)
20	22	A	2	1 1/4-18 UNEF	1.343 (34.1)	1.437 (36.5)
21	24	A	2	1 3/8-18 UNEF	1.468 (37.3)	1.562 (39.7)
22	28	A	2	1 5/8-18 UNEF	1.593 (40.5)	1.812 (46.0)
23	32	A	1	1 7/8-16 UN	2.125 (54.0)	2.062 (52.4)
24	32	L, M, N	2	1 7/8-16 UN	2.125 (54.0)	2.062 (52.4)
25	32	H, J	3	1 29/32-18 UNS	2.125 (54.0)	2.062 (52.4)
26	36	A	1	2 1/8-16 UN	2.375 (60.3)	2.312 (58.7)
27	36	M, N	2	2 1/8-16 UN	2.375 (60.3)	2.312 (58.7)
28	36	L	3	2 1/16-16 UNS	2.375 (60.3)	2.312 (58.7)
29	36	J	3	2 1/16-20 UNEF	2.375 (60.3)	1.312 (33.3)
30	36	H	3	2 1/8-18 UNS	2.375 (60.3)	2.312 (58.7)

G



SERIES 77 Metal Shrink Boot Adapters



Adapter Reference Guide - Connector Designator "B" Ordering Information for MIL-DTL-5015

MS3100 Series Manufacturer Designations						
Dash Number	Shell Size	Connector Manufacturer Desig	See Note 1	A Thread Class 2B	B Dia Max	C Dia Max
31	40	A	1	2 3/8 - 16 UN	2.625 (66.7)	2.562 (65.1)
32	40	H, M, N	2	2 3/8 - 16 UN	2.625 (66.7)	2.562 (65.1)
33	40	L	3	2 5/16 - 16 UNS	2.625 (66.7)	2.562 (65.1)
34	44	A	2	2 5/8 - 16 UN	2.906 (73.8)	2.875 (73.0)
35	48	A	1	2 7/8 - 16 UN	3.156 (80.2)	3.125 (79.4)
36	48	H	2	2 7/8 - 16 UN	3.156 (80.2)	3.125 (79.4)
37	48	N	3	2 13/16 - 18 UNS	3.156 (80.2)	3.125 (79.4)

How to Order Adapters for MIL-DTL-5015 (MS3100 Series) Connectors

The threads and interface dimensions on MIL-DTL-5015 solder-type connectors are unfortunately not standardized from one manufacturer to the next. As a result, there is limited interchangeability in many shell sizes and service classes amongst available MS3100 Series products. When ordering adapters for 5015 connectors it is therefore necessary to treat each connector manufacturer's product separately to ensure optimum compatibility of the adapter-to-connector interface. This is accomplished in two steps: (1) Use the connector designator "B" in the normal place in the part number to indicate to the factory that a MIL-DTL-5015 (MS3100 Series) connector is being used; and (2) Use an additional connector manufacturer symbol, as shown in the part number development example below, to indicate whose MIL-DTL-5015 product you are using. Connector manufacturer symbols for 5015 products are shown in the table below and pertinent connector fitting interface information is given on page F-6.

Please Note: For proper use of Glenair adapters with MS3100 Series connectors, discard all rear hardware, including wire seal grommets, normally supplied with the connector. (This information does not apply to endbell extenders commonly supplied with MS3100A Series connectors.)

How to Order										
Sample Part Number	310	B	S	004	B	17	10	E	6	A
Product Series	310									
Connector Designator (MS3100 Series)	B									
Angular Function	H = 45° (Die Cast) J = 90° (Die Cast) S = Straight									
Basic Part Number	004									
Finish Symbol	B									
Dash Number	See Shrink Boot Adapter Selection and Reference Guide Table 1. Note: Do not use shell size, as dash number does not always correspond to shell size.									
Cable Entry Code	If available enter dash number of code									
Strain Relief Style	If option available									
Length	Applies to straight only and is measured in 1/2 inch (12.7) increments									
Connector Manufacturer Symbol	See 5015 Connector Manufacturer Symbols table to the right									

MIL-DTL-5015 Connector Designator Reference			
Symbol	Mfr	Connector Series	Class
A	All	MS3100, 01, 06	A/E/F/R
H	Amphenol	MS3100, 01, 06 97 Series Blue Insert	A
J		MS3100, 01, 06	E/F/R
L	Amphenol/ BCO	MS3100, 01, 06 10-214,10-720 10-721,10-726	A/E/F/R
M	Cannon	MS3100, 01, 06	A
N	Cannon	MS3100, 01, 063 CA00, 01, 06	E/F/R





SERIES 77

Metal Shrink Boot Adapters



310-001 Standard Profile, O-Ring Sealed Shrink Boot Adapter with Rotatable Coupling

How to Order	
Sample Part Number	310 F S 001 M 16 D T
Product Series	310
Connector Designator	See Connector Designator Table
Angular Function	S = straight H = 45° J = 90°
Basic Part Number	001
Finish Symbol	B = cadmium plate, olive drab C* = anodize, black G* = hard coat, anodic M = electroless nickel NF = cadmium plate, olive drab over electroless nickel (1000 hour salt spray) *Non-conductive finish not suitable for EMI/RFI shielding applications
Shell Size	See dimensions table
Drain Hole	D = drain hole Omit for none
Shrink Boot	T = shrink boot Omit for none; see dimensions table for part number



Add "T" to Part Number for Standard Boot

Connector Designator	
A	MIL-DTL-5015, -26482, Series II and -83723 Series I and III
D	MIL-DTL-26482 Series I
F	MIL-DTL-38999 Series I, II
G*	MIL-DTL-28840
H	MIL-DTL-38999 Series III and IV
J*	MIL-DTL-81511 Series I, II, III & IV
L	LN29729
S	PATT 105, PATT 603, PATT 608
ROTATABLE COUPLING	

*For connector designators G and J, please consult the factory for 45° and 90° configurations

NOTES

1. See Table I on page G-4 for connector designator interface dimensions
2. O-Rings not supplied with Connector Designators A and G or with drain hole option
3. For G connector designator dimension E and G will be increased .360 (9.14)
4. Standard Boot Kit includes a straight lipped, type 1 material boot without adhesive. For additional material adhesive options order separately from section B
5. Glenair 600 series backshell assembly tools are recommended for assembly and installation
6. Recovered dimension apply to unrestricted recovery. Dimensions may differ than shown when boots are installed over assembly

G



SERIES 77

Metal Shrink Boot Adapters



310-001 Standard Profile, O-Ring Sealed Shrink Boot Adapter with Rotatable Coupling

See Pages G-4 and G-5 for Adapter Interface Dimensions

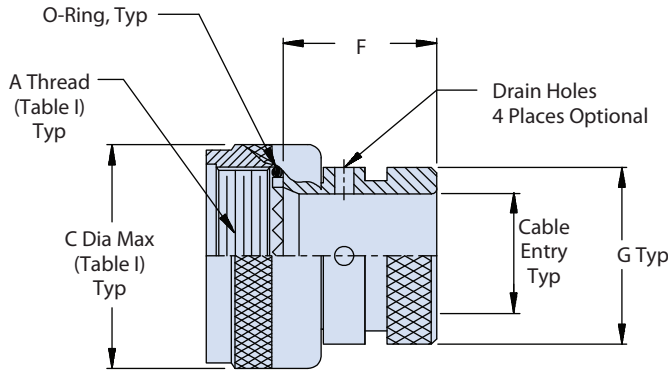

SYM S
Straight

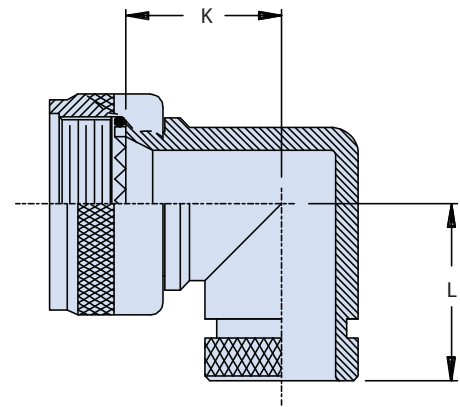

SYM J
90°

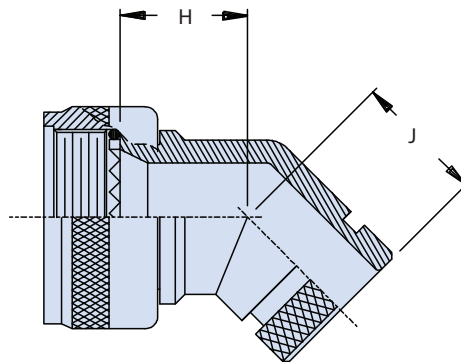

SYM H
45°



Dimensions									
Shell Size - Conn. Desig.		F	G	H	J	K	L	Cable Entry	Shrink Boot
A-F-J-L-S	G-H	Max	Max	Max	Max	Max	Max	Minimum	Part Number*
08	09	.940 (23.9)	.533 (13.5)	.639 (16.2)	.810 (20.6)	.750 (19.1)	.920 (23.4)	.250 (6.4)	770-003S102
10	11	.940 (23.9)	.605 (15.4)	.664 (16.9)	.840 (21.3)	.810 (20.6)	.980 (24.9)	.355 (9.0)	770-001S103
12	13	.940 (23.9)	.774 (19.7)	.688 (17.5)	.860 (21.8)	.870 (22.1)	1.040 (26.4)	.491 (12.5)	770-001S103
14	15	.940 (23.9)	.838 (21.3)	.705 (17.9)	.890 (22.6)	.920 (23.4)	1.110 (28.2)	.565 (14.4)	770-001S103
16	17	.940 (23.9)	.963 (24.5)	.732 (18.6)	.910 (23.1)	.980 (24.9)	1.170 (29.7)	.690 (17.5)	770-001S104
18	19	.940 (23.9)	1.042 (26.5)	.748 (19.0)	.920 (23.4)	1.020 (25.9)	1.190 (30.2)	.769 (19.5)	770-001S104
20	21	.940 (23.9)	1.217 (30.9)	.773 (19.6)	.940 (23.9)	1.080 (27.4)	1.250 (31.8)	.894 (22.7)	770-001S106
22	23	.940 (23.9)	1.355 (34.4)	.800 (20.3)	.980 (24.9)	1.140 (29.0)	1.330 (33.8)	1.019 (25.9)	770-001S107
24	25	.940 (23.9)	1.443 (36.7)	.823 (20.9)	1.010 (25.7)	1.200 (30.5)	1.400 (35.6)	1.134 (28.8)	770-001S107
28	29	.940 (23.9)	1.709 (43.4)	1.041 (26.4)	1.180 (30.0)	1.480 (37.6)	1.640 (41.7)	1.369 (34.8)	770-001S108
32	33	1.005 (25.5)	1.919 (48.7)	1.092 (27.7)	1.370 (34.8)	1.610 (40.9)	1.880 (47.8)	1.615 (41.0)	770-001S108

*Equivalent boot may be supplied in lieu of stated part number.



SERIES 77

Metal Shrink Boot Adapters



310-034 Standard Profile, O-Ring Sealed Shrink Boot Adapter with Direct Coupling

How to Order	
Sample Part Number	310 D S 034 M 16 T
Product Series	310
Connector Designator	See connector designator table
Angular Function	S = straight H = 45° J = 90°
Basic Part Number	034
Finish Symbol	B = cadmium plate, olive drab C = anodize, black G = hard coat, anodic M = electroless nickel NF = cadmium plate, olive drab over electroless nickel
Shell Size	See interface adapter dimensions table
Shrink Boot	Omit for none; see cable entry and shrink boot table



Add "T" to Part Number for Standard Boot

Connector Designator			
A	MIL-DTL-5015, -26482, Series II and -83723 Series I and III	G	MIL-DTL-28840
B*	MIL-DTL-5015	H	MIL-DTL-38999 Series III and IV
C	MIL-DTL-22992	J	MIL-DTL-81511 Series I, II, III & IV
D	MIL-DTL-26482	K	MIL-DTL-83723 Series II
E	MIL-DTL-26500	L	LN29729
F	MIL-DTL-38999 Series I, II	S	PATT 105, PATT 603, PATT 608
DIRECT COUPLING			

*When using Designator B, refer to Pages F-6 and F-7

Interface Adapter Dimension			
Shell Size	J Max - Connector Designator		
	A-E-F-J-H-S	D-B-G-K	C
08/09	1.180 (30.0)	1.250 (31.8)	-
10/11	1.180 (30.0)	1.250 (31.8)	-
12/13	1.180 (30.0)	1.250 (31.8)	1.735(44.1)
14/15	1.180 (30.0)	1.250 (31.8)	1.915(48.6)
16/17	1.380 (35.0)	1.560 (39.6)	1.915(48.6)
18/19	1.380 (35.0)	1.560 (39.6)	1.915(48.6)
20/21	1.380 (35.0)	1.560 (39.6)	1.915(48.6)
22/23	1.380 (35.0)	1.560 (39.6)	1.915(48.6)
24/25	1.380 (35.0)	1.560 (39.6)	1.915(48.6)
28/29	1.610 (40.9)	1.560 (39.6)	1.915(48.6)
32/33	1.610 (40.9)	1.750 (44.5)	1.915(48.6)
36	1.610 (40.9)	1.750 (44.5)	1.915(48.6)
40	1.610 (40.9)	2.190 (55.6)	1.915(48.6)

Shell Size	Dimensions			
	F Max	G Max	H Max	K Max
08/09	.639 (16.2)	.810 (20.6)	.750 (19.1)	.920 (23.4)
10/11	.664 (16.9)	.840 (21.3)	.810 (20.6)	.980 (24.9)
12/13	.688 (17.5)	.860 (21.8)	.870 (22.1)	1.040 (26.4)
14/15	.705 (17.9)	.890 (22.6)	.920 (23.4)	1.110 (28.2)
16/17	.732 (18.6)	.910 (23.1)	.980 (24.9)	1.170 (29.7)
18/19	.748 (19.0)	.920 (23.4)	1.020 (25.9)	1.190 (30.2)
20/21	.773 (19.6)	.940 (23.9)	1.080 (27.4)	1.250 (31.8)
22/23	.800 (20.3)	.980 (24.9)	1.140 (29.0)	1.330 (33.8)
24/25	.823 (20.9)	1.010 (25.7)	1.200 (30.5)	1.400 (35.6)
28	1.041 (26.4)	1.180 (30.0)	1.480 (37.6)	1.640 (41.7)
32	1.092 (27.7)	1.370 (34.8)	1.610 (40.9)	1.880 (47.8)
36	1.041 (26.4)	1.180 (30.0)	1.480 (37.6)	1.640 (41.7)
40	1.092 (27.7)	1.370 (34.8)	1.610 (40.9)	1.880 (47.8)



SERIES 77 Metal Shrink Boot Adapters



310-034 Standard Profile, O-Ring Sealed Shrink Boot Adapter with Direct Coupling

See Pages G-4 and G-5 for Adapter Interface Dimensions

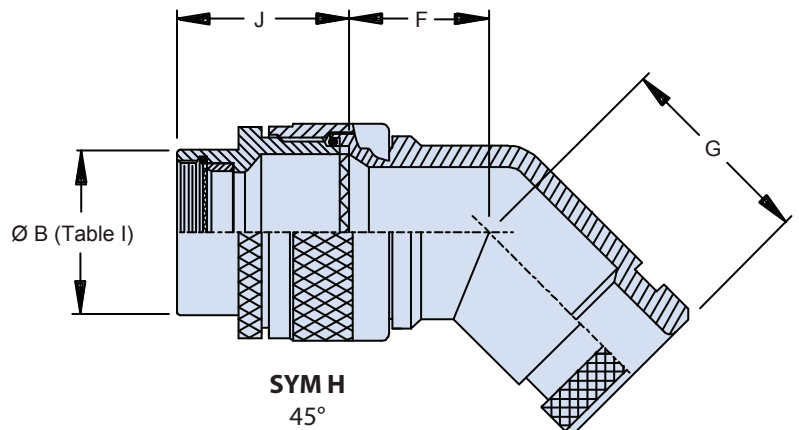
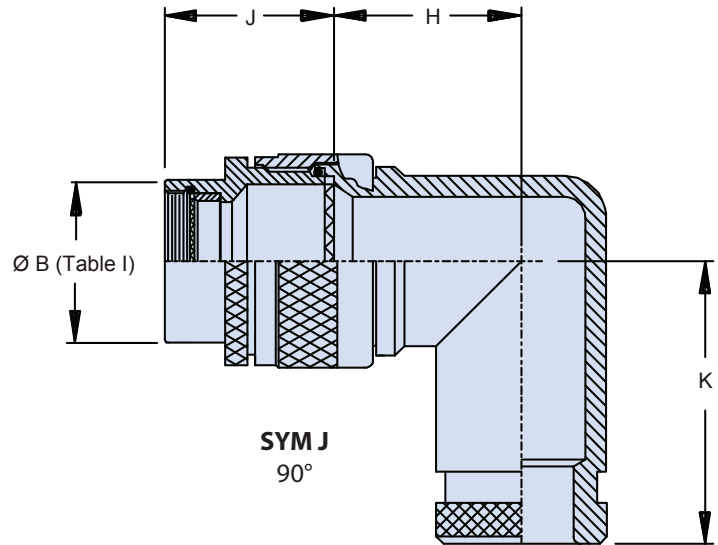
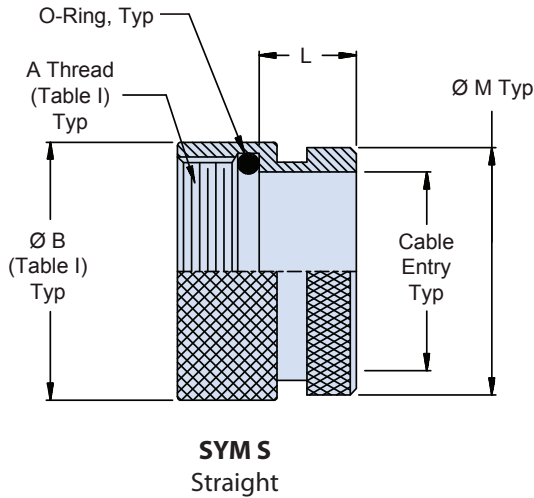

Cable Entry Dimensions and Shrink Boot Part Numbers				
Shell Size	L Max	M Max	Cable Entry Minimum	Shrink Boot Part Number
08	.500 (12.7)	.688 (17.5)	.250 (6.4)	770-001S103
10/11	.500 (12.7)	.803 (20.4)	.355 (9.0)	770-001S103
12/13	.500 (12.7)	.938 (23.8)	.491 (12.5)	770-001S104
14/15	.500 (12.7)	1.063 (27.0)	.565 (14.4)	770-001S106
16/17	.500 (12.7)	1.238 (31.4)	.690 (17.5)	770-001S106
18	.500 (12.7)	1.310 (33.3)	.769 (19.5)	770-001S107
20	.500 (12.7)	1.436 (36.5)	.844 (21.4)	770-001S107
22	.500 (12.7)	1.560 (39.6)	1.019 (25.9)	770-001S108
24	.500 (12.7)	1.686 (42.8)	1.134 (28.8)	770-001S108
28	.687 (17.4)	2.062 (52.4)	1.369 (34.8)	770-001S109
32	.687 (17.4)	2.312 (58.7)	1.615 (41.0)	770-001S108
36	.687 (17.4)	2.562 (65.1)	1.830 (46.5)	Consult Factory
40	.687 (17.4)	2.812 (71.4)	2.045 (51.9)	Consult Factory

NOTES

1. See Table I on page G-4 for connector designator interface dimensions
2. When using Connector Designator B refer to pages G-6 and G-7 for part number development.
3. Standard Boot Kit includes a straight lipped, type 1 material boot without adhesive. For additional material adhesive options order separately from section B
4. Glenair 600 series backshell assembly tools are recommended for assembly and installation
5. Recovered dimension apply to unrestricted recovery. Dimensions may differ than shown when boots are installed over assembly



SERIES 77

Metal Shrink Boot Adapters



311-001 Low Profile, Lamp-Base Threaded, EMI/RFI Adapter with Rotatable Coupling

How to Order	
Sample Part Number	311 F S 001 M 18 05 E T
Product Series	311
Connector Designator	See connector designator table
Angular Function	S = straight H = 45° J = 90°
Basic Part Number	001
Finish Symbol	B = cadmium plate, olive drab C = anodize, black G = hard coat, anodic M = electroless nickel NF = cadmium plate, olive drab over electroless nickel
Shell Size	See dimensions table
Cable Entry Dash No.	See cable entry dash number table
Strain Relief	E = strain relief Omit for nut
Shrink Boot	Omit for none; see cable entry table



Add "T" to Part Number for Standard Boot

NOTES

- See Table I on page G-4 for connector designator interface dimensions
- When dash no, exceeds "max dash no" in Dimensions Table, Style 2 will be supplied. Dimensions F, G, H & J will not apply.
- Cable Entry is defined as the accommodation range for the wire bundle or cable. Dimensions shown are not intended for inspection criteria
- Standard Boot Kit includes straight lipped, type 1 material boot without adhesive. For additional material adhesive options order separately from section B
- Glenair 600 series backshell assembly tools are recommended for assembly and installation
- Recovered dimension apply to unrestricted recovery. Dimensions may differ than shown when boots are installed over assembly

Connector Designator	
A	MIL-DTL-5015, -26482, Series II and -83723 Series I and III
F	MIL-DTL-38999 Series I, II
H	MIL-DTL-38999 Series III and IV
L	LN29729
ROTATABLE COUPLING	

G

Dimensions								
Shell Size - Conn. Desig.		F Max	G Max	H Max	J Max	Max Dash No See Cable Entry Table		
A-F-L	H					A	F, H	L
08	09	.830 (21.08)	1.045 (26.54)	.940 (23.88)	1.155 (29.34)	02	02	02
10	11	.860 (21.84)	1.075 (27.30)	1.010 (25.65)	1.225 (31.12)	03	03	03
12	13	.882 (22.40)	1.097 (27.86)	1.070 (27.18)	1.285 (32.64)	04	04	04
14	15	.900 (22.86)	1.125 (28.57)	1.130 (28.70)	1.345 (34.16)	04	05	05
16	17	.930 (23.62)	1.145 (29.08)	1.190 (30.23)	1.405 (35.71)	05	06	06
18	19	.950 (24.13)	1.165 (29.59)	1.240 (31.50)	1.455 (36.96)	06	06	07
20	21	.980 (24.89)	1.195 (30.35)	1.310 (33.27)	1.525 (38.73)	07	07	08
22	23	1.000 (25.40)	1.215 (30.86)	1.360 (34.54)	1.575 (40.00)	08	08	09
24	25	1.030 (26.16)	1.245 (31.62)	1.430 (36.32)	1.645 (41.78)	09	09	10
28	--	1.240 (31.50)	1.620 (41.15)	1.481 (37.62)	1.766 (44.86)	11	--	--
32	--	1.292 (32.82)	1.750 (44.45)	1.798 (45.67)	1.886 (47.90)	12	--	--

Cable Entry Dash Number				
Dash No.	K Max	L Max	Max Cable Entry	Shrink Boot
01	.448 (11.4)	.781 (19.8)	.125 (3.2)	--
02	.515 (13.1)	.968 (24.6)	.250 (6.4)	770-001S1 03
03	.640 (16.3)	1.046 (26.6)	.375 (9.5)	770-001S1 03
04	.765 (19.4)	1.156 (29.4)	.500 (12.7)	770-001S1 04
05	.920 (23.4)	1.219 (31.0)	.625 (15.9)	770-001S1 04
06	1.015 (25.8)	1.343 (34.1)	.750 (19.1)	770-001S1 05
07	1.140 (29.0)	1.469 (37.3)	.875 (22.2)	770-001S1 06
08	1.265 (32.1)	1.594 (40.5)	1.000 (25.4)	770-001S1 06
09	1.432 (36.4)	1.719 (43.7)	1.125 (28.6)	770-001S1 07
10	1.515 (38.5)	1.844 (46.8)	1.250 (31.8)	770-001S1 07
11	1.640 (41.7)	--	1.375 (34.9)	770-001S1 08
12	1.765 (44.8)	--	1.500 (38.1)	770-001S1 08
13	2.015 (51.2)	--	1.750 (44.5)	770-001s1 08



SERIES 77

Metal Shrink Boot Adapters



311-001 Low Profile, Lamp-Base Threaded, EMI/RFI Adapter with Rotatable Coupling

See Pages G-4 and G-5 for Adapter Interface Dimensions

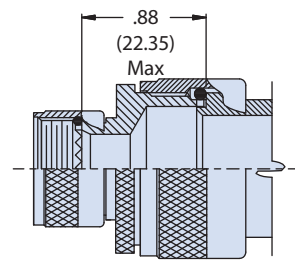
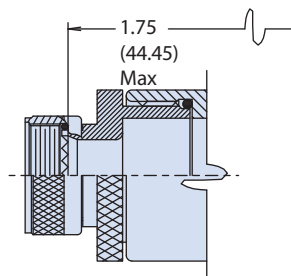
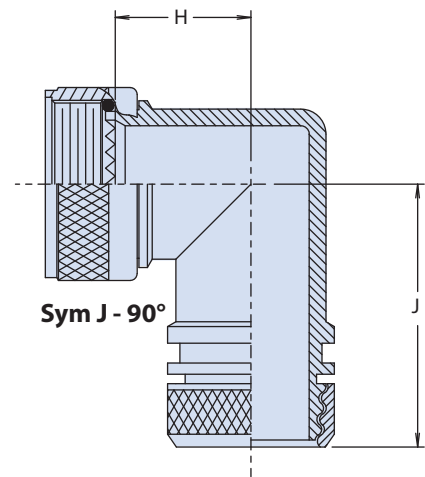
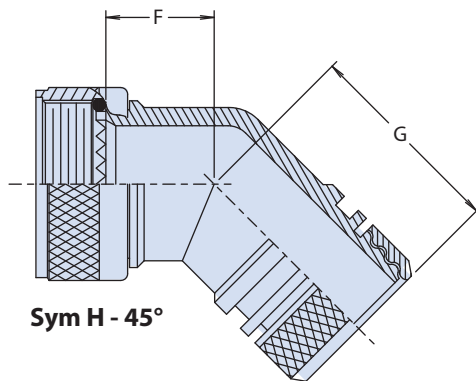
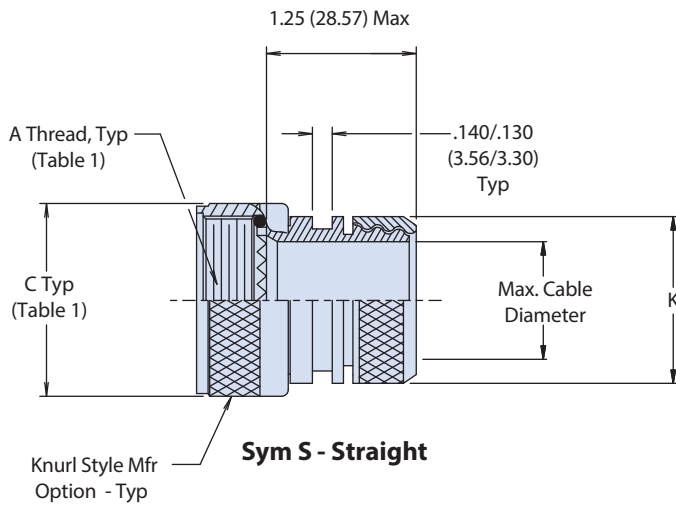



SERIES 77 Metal Shrink Boot Adapters



319-001 Low Profile EMI/RFI Adapter with Rotatable Coupling and Shield Sock

How to Order									
Sample Part Number	319	F	S	001	M	16	06	-6	T
Product Series	319								
Connector Designator	See connector designator table								
Angular Function	B = 45° A = 90° S = straight								
Basic Part Number	001								
Finish Symbol	B = cadmium plate, olive drab C = anodize, black G = hard coat, anodic M = electroless nickel NF = cadmium plate, olive drab over electroless nickel								
Shell Size	See dimensions table								
Cable Entry Dash No.	See cable entry dash number table								
Shield Length	1-inch increments, minimum 4 Inches								
Shrink Boot	Omit for none; see cable entry and shrink boot table								

Add "T" to Part Number
for Standard Boot

Connector Designator	
A	MIL-DTL-5015, -26482, Series II and -83723 Series I and III
F	MIL-DTL-38999 Series I, II
H	MIL-DTL-38999 Series III and IV
L	LN29729
S	PATT 105, PATT 603, PATT 608
ROTATABLE COUPLING	

NOTES

- See Table I on page G-4 for connector designator interface dimensions
- Cable Entry is defined as the accomodation range for the wire bundle or cable. Dimensions shown are not intended for inspection criteria.
- O-Ring not supplied with Connector Designator A.
- When maximum entry is exceeded, Style 2 will be supplied and dimensions F, G, H and J will not apply. Please consult factory.
- Standard Boot Kit includes a straight lipped, type 1 material boot without adhesive. For additional material adhesive options order separately from section B
- Glenair 600 series backshell assembly tools are recommnded for assembly and installation
- Recovered dimension apply to unrestricted recovery. Dimensions may differ than shown when boots are installed over assembly

G

Dimensions					
Shell Size - Conn. Desig.		F Max	G Max	H Max	J Max
A-F-L-S	H				
08	09	.457 (11.6)	1.710 (43.4)	.500 (12.7)	1.730 (43.9)
10	11	.520 (13.2)	1.770 (45.0)	.595 (15.1)	1.850 (47.0)
12	13	.582 (14.8)	1.830 (46.5)	.610 (15.5)	1.870 (47.5)
14	15	.645 (16.4)	1.920 (48.8)	.700 (17.8)	1.940 (49.3)
16	17	.738 (18.7)	2.030 (51.6)	.885 (22.5)	2.030 (51.6)
18	19	.926 (23.5)	2.220 (56.4)	.975 (24.8)	2.200 (55.9)
20	21	.926 (23.5)	2.220 (56.4)	.975 (24.8)	2.200 (55.9)
22	23	1.020 (25.9)	2.370 (60.2)	1.125 (28.6)	2.310 (58.7)
24	25	1.020 (25.9)	2.370 (60.2)	1.125 (28.6)	2.310 (58.7)
28		1.145 (29.1)	2.420 (61.5)	1.225 (31.1)	2.480 (63.0)
32		1.207 (30.7)	2.520 (64.0)	1.575 (40.0)	2.730 (69.3)
36		1.238 (31.4)	2.610 (66.3)	1.775 (45.1)	2.730 (69.3)



SERIES 77 Metal Shrink Boot Adapters



319-001 Low Profile EMI/RFI Adapter with Rotatable Coupling and Shield Sock

See Pages G-4 and G-5 for Adapter Interface Dimensions

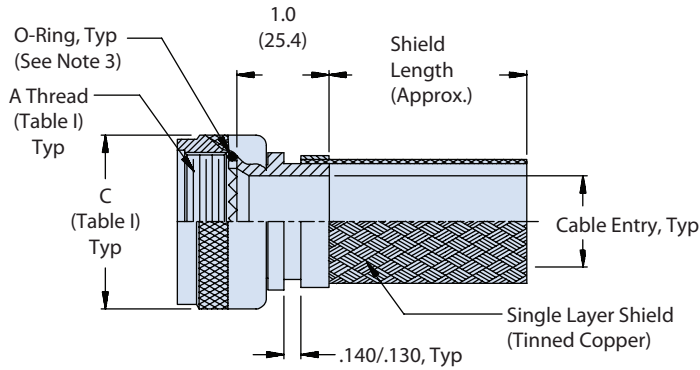

Sym S - Straight

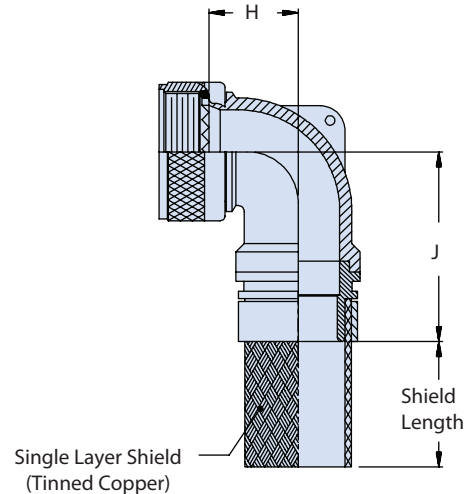

Sym A - 90°

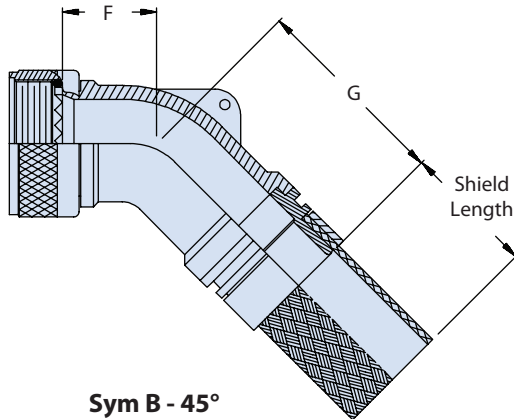

Sym B - 45°

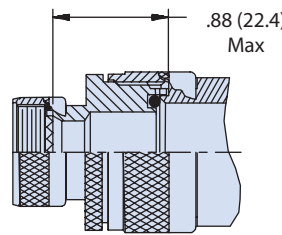

STYLE II
(45 and 90°)
See Note 4

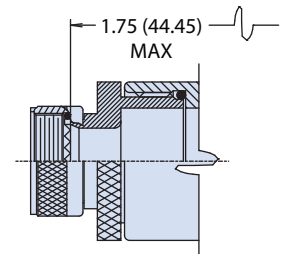

STYLE II
(STRAIGHT ONLY)
See Note 4

Cable Entry and Shrink Boot					
Dash No.	Cable Entry	Shrink Boot Part Number	Dash No.	Cable Entry	Shrink Boot Part Number
01	.188 (4.8)	N/A	13	.938 (23.8)	770-001S106
02	.250 (6.4)	N/A	14	1.000 (25.4)	770-001S106
03	.312 (7.9)	770-001S103	15	1.250 (31.8)	770-001S107
04	.375 (9.5)	770-001S103	16	1.500 (38.1)	770-001S108
05	.438 (11.1)	770-001S103	17	1.750 (44.5)	770-001S108
06	.500 (12.7)	770-001S104	18	2.000 (50.8)	770-001S109
07	.562 (14.3)	770-001S104	19	1.125 (28.6)	770-001S107
08	.625 (15.9)	770-001S104	20	1.375 (34.9)	770-001S107
09	.688 (17.5)	770-001S105	21	1.625 (41.3)	770-001S108
10	.750 (19.1)	770-001S105	22	1.062 (27.0)	770-001S106
11	.812 (20.6)	770-001S105	23	1.188 (30.2)	770-001S107
12	.875 (22.2)	770-001S106	24	1.875 (47.6)	770-001S109





SERIES 77

Metal Shrink Boot Adapters



319-044 Standard Profile EMI/RFI Adapter with Rotatable Self-Locking Coupling and Shield Sock

How to Order	
Sample Part Number	319 F J 044 M 16 06 -6 -4 T
Product Series	319
Connector Designator	See connector designator table
Angular Function	H = 45° J = 90° S = straight
Basic Part Number	044
Finish Symbol	B = cadmium plate, olive drab C = anodize, black G = hard coat, anodic M = electroless nickel NF = cadmium plate, olive drab over electroless nickel
Shell Size	See dimensions table
Cable Entry Dash No.	See cable entry dash number table
Shield Length	1-inch increments, minimum 6 Inches
Length (S Only)	1/2-inch increments (e.g. 4 = 2 inches)
Shrink Boot	T = shrink boot; see cable entry and shrink boots table Omit for none

Connector Designator	
A	MIL-DTL-5015, -26482, Series II and -83723 Series I and III
F	MIL-DTL-38999 Series I, II
H	MIL-DTL-38999 Series III and IV
L	LN29729
S	PATT 105, PATT 603, PATT 608
ROTATABLE COUPLING SELF-LOCKING	

Dimensions					
Shell Size - Conn. Desig.		F Max	G Max	H Max	J Max
A-F-L-S	H				
08	09	.986 (25.0)	1.045 (26.5)	1.096 (27.8)	1.155 (29.3)
10	11	1.016 (25.8)	1.075 (27.3)	1.166 (29.6)	1.225 (31.1)
12	13	1.038 (26.4)	1.097 (27.9)	1.226 (31.1)	1.285 (32.6)
14	15	1.056 (26.8)	1.125 (28.6)	1.286 (32.7)	1.345 (34.2)
16	17	1.066 (27.1)	1.145 (29.1)	1.346 (34.2)	1.405 (35.7)
18	19	1.106 (28.1)	1.165 (29.6)	1.396 (35.5)	1.455 (37.0)
20	21	1.136 (28.9)	1.195 (30.4)	1.466 (37.2)	1.525 (38.7)
22	23	1.156 (29.4)	1.215 (30.9)	1.516 (38.5)	1.575 (40.0)
24	25	1.186 (30.1)	1.245 (31.6)	1.586 (40.3)	1.645 (41.8)



Add "T" to Part Number for Standard Boot

Cable Entry and Shrink Boots		
Dash No.	Cable Entry	Shrink Boot Part Number
01	.188 (4.8)	N/A
02	.250 (6.4)	N/A
03	.312 (7.9)	770-001S103
04	.375 (9.5)	770-001S103
05	.438 (11.1)	770-001S103
06	.500 (12.7)	770-001S104
07	.562 (14.3)	770-001S104
08	.625 (15.9)	770-001S104
09	.688 (17.5)	770-001S105
10	.750 (19.1)	770-001S105
11	.812 (20.6)	770-001S105
12	.875 (22.2)	770-001S106
13	.938 (23.8)	770-001S106
14	1.000 (25.4)	770-001S106
15	1.250 (31.8)	770-001S107
16	1.500 (38.1)	770-001S107
17	1.750 (44.5)	770-001S108
18	2.000 (50.8)	770-001S109
19	1.125 (28.6)	770-001S107
20	1.375 (34.9)	770-001S107
21	1.625 (41.3)	770-001S108
22	1.062 (27.0)	770-001S106
23	1.188 (30.2)	770-001S107
24	1.875 (47.6)	770-001S109

G



SERIES 77

Metal Shrink Boot Adapters



319-044 Standard Profile EMI/RFI Adapter with Rotatable Self-Locking Coupling and Shield Sock

See Pages G-4 and G-5 for Adapter Interface Dimensions



Sym S - Straight

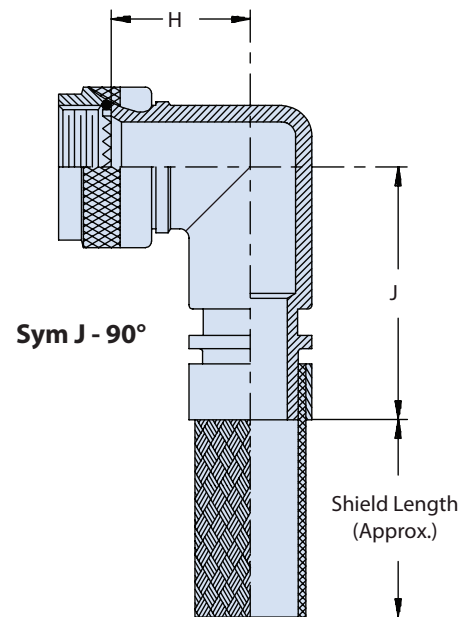

Sym J - 90°

NOTES

1. Cable Entry is defined as the accommodation range for the wire bundle or cable. Dimensions shown are not intended for inspection criteria.
2. O-Ring not supplied with Connector Designator A.
3. When maximum entry is exceeded, Style II will be supplied. Dimensions F, G, H and J will not apply.
4. For shorter lengths on straight adapters, please consult the factory
5. Standard Boot Kit includes a straight lipped, type 1 material boot without adhesive. For additional material adhesive options order separately from section B
6. Glenair 600 series backshell assembly tools are recommended for assembly and installation
7. Recovered dimension apply to unrestricted recovery. Dimensions may differ than shown when boots are installed over assembly

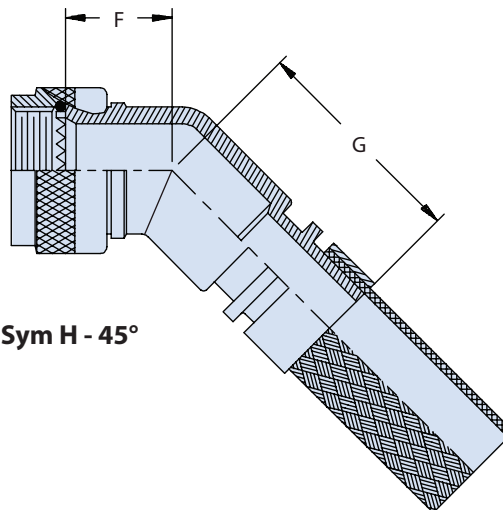

Sym H - 45°

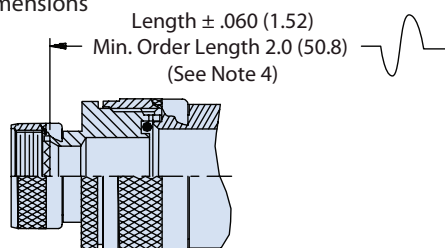

**STYLE II
STRAIGHT
See Note 3**

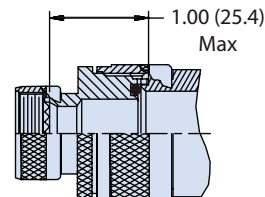

**STYLE II
45° & 90°
See Note 3**





SERIES 77

Metal Shrink Boot Adapters



440-069 Standard Profile, EMI/RFI Adapter with Banding Porch and Self-Locking Rotatable Coupling

How to Order	
Sample Part Number	440 F S 069 M 20 12 -8 B P T
Product Series	440
Connector Designator	See connector designator table
Angular Function	H = 45° J = 90° S = straight
Basic Part Number	069
Finish Symbol	B = cadmium plate, olive drab C = anodize, black G = hard coat, anodic M = electroless nickel NF = cadmium plate, olive drab over electroless nickel
Shell Size	See dimensions table
Cable Entry Dash No.	See dimensions table
Length (S Only)	1/2-inch increments (e.g. 4 = 2 inches)
Band	B = band K = precoiled Omit for none
Polysulfide Option	P = polysulfide Omit for none; see note 6
Shrink Boot	T, T1, H, H1 Omit for none; see cable entry and shrink boot table



Add "T" to Part Number for Standard Boot

Connector Designator	
A	MIL-DTL-5015, -26482, Series II and -83723 Series I and III
F	MIL-DTL-38999 Series I, II
H	MIL-DTL-38999 Series III and IV
L	LN29729
ROTATABLE COUPLING	
SELF-LOCKING	

Shrink Boot Options	
Sym	Description
T	Standard Shrink Boot (* = 1)
T1	Standard precoated with W1 Hot Melt Adhesive (*=1)
H	Zero Halogen Shrink Boot (* = 2)
H1	Zero Hologen with Pre-Coated W1 Hot Melt Adhesive (* = 2)
To re-order boot select symbol code in table. Asterisk indicates code for material type. Substitute code in boot part number reference according to adhesive option in Cable Entry table	

Cable Entry and Shrink Boot					
Dash No.	K Dia	L Dia	M Dia	T or H Std Boot Ref.	T1 or H1 w/ Adhesive Ref.
01	.125 (3.2)	.250 (6.4)	.312 (7.9)	770-003S*11	770-003S*11W1
31	.188 (4.8)	.312 (7.9)	.374 (9.5)	770-003S*11	770-003S*11W1
02	.250 (6.4)	.375 (9.5)	.437 (11.1)	770-003S*12	770-003S*12W1
32	.312 (7.9)	.438 (11.1)	.500 (12.7)	770-003S*12	770-003S*12W1
03	.375 (9.5)	.500 (12.7)	.562 (14.3)	770-003S*12	770-003S*12W1
33	.438 (11.1)	.562 (14.3)	.624 (15.8)	770-001S*04	770-001S*04W1
04	.500 (12.7)	.625 (15.9)	.687 (17.4)	770-001S*04	770-001S*04W1
34	.562 (14.3)	.688 (17.5)	.750 (19.1)	770-001S*04	770-001S*04W1
05	.625 (15.9)	.750 (19.1)	.812 (20.6)	770-001S*04	770-001S*04W1
35	.688 (17.5)	.812 (20.6)	.874 (22.2)	770-001S*04	770-001S*04W1
06	.750 (19.1)	.875 (22.2)	.937 (23.8)	770-001S*05	770-001S*05W1
36	.812 (20.6)	.938 (23.8)	1.000 (25.4)	770-001S*05	770-001S*05W1
07	.875 (22.2)	1.000 (25.4)	1.062 (27.0)	770-001S*05	770-001S*05W1
37	.938 (23.8)	1.062 (27.0)	1.124 (28.5)	770-001S*05	770-001S*05W1
08	1.000 (25.4)	1.125 (28.6)	1.187 (30.1)	770-001S*06	770-001S*06W1
38	1.062 (27.0)	1.188 (30.2)	1.250 (31.8)	770-001S*06	770-001S*07W1
09	1.125 (28.6)	1.250 (31.8)	1.312 (33.3)	770-001S*07	770-001S*07W1
10	1.250 (31.8)	1.375 (34.9)	1.437 (36.5)	770-001S*07	770-001S*07W1
11	1.375 (34.9)	1.500 (38.1)	1.562 (39.7)	770-001S*07	770-001S*07W1
12	1.500 (38.1)	1.625 (41.3)	1.687 (42.8)	770-001S*07	770-001S*07W1
13	1.625 (41.3)	1.750 (44.5)	1.812 (46.0)	770-001S*08	770-001S*08W1
14	1.750 (44.5)	1.875 (47.6)	1.937 (49.2)	770-001S*08	770-001S*08W1
15	1.875 (47.6)	2.000 (50.8)	2.062 (52.4)	770-001S*09	770-001S*09W1
16	2.000 (50.8)	2.125 (54.0)	2.187 (55.5)	770-001S*09	770-001S*09W1

Dimensions					
Shell Size - Conn. Desig.		F	G	H	J
A-F-L	H	Max	Max	Max	Max
08	09	.806 (20.5)	1.038 (26.4)	.906 (23.0)	1.146 (29.1)
10	11	.832 (21.1)	1.064 (27.0)	.966 (24.5)	1.210 (30.7)
12	13	.856 (21.7)	1.088 (27.6)	1.026 (26.1)	1.268 (32.2)
14	15	.882 (22.4)	1.114 (28.3)	1.076 (27.3)	1.330 (33.8)
16	17	.908 (23.1)	1.150 (29.2)	1.136 (28.9)	1.392 (35.4)
18	19	.927 (23.5)	1.190 (30.2)	1.176 (29.9)	1.438 (36.5)
20	21	.953 (24.2)	1.250 (31.8)	1.236 (31.4)	1.500 (38.1)
22	23	.979 (24.9)	1.320 (33.5)	1.296 (32.9)	1.562 (39.7)
24	25	1.004 (25.5)	1.380 (35.1)	1.356 (34.4)	1.625 (41.3)
28		1.197 (30.4)	1.500 (38.1)	1.422 (36.1)	1.654 (42.0)
32		1.280 (32.5)	1.620 (41.1)	1.545 (39.2)	1.777 (45.1)
36		1.294 (32.9)	1.750 (44.5)	1.652 (42.0)	1.844 (46.8)



SERIES 77 Metal Shrink Boot Adapters



440-069 Standard Profile, EMI/RFI Adapter with Banding Porch and Self-Locking Rotatable Coupling

See Pages G-4 and G-5 for Adapter Interface Dimensions

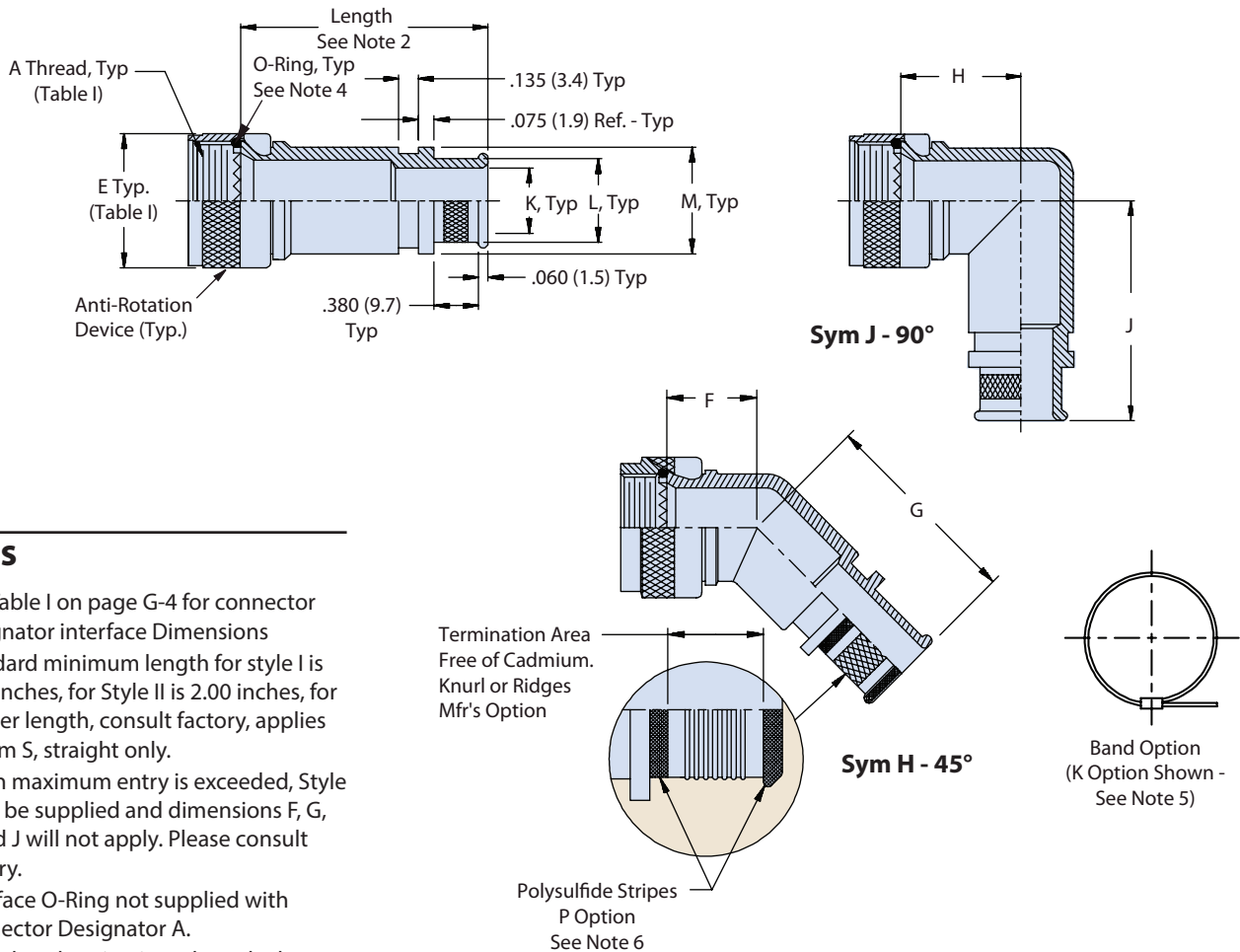

NOTES

1. See Table I on page G-4 for connector designator interface Dimensions
2. Standard minimum length for style I is 1.50 inches, for Style II is 2.00 inches, for shorter length, consult factory, applies to Sym S, straight only.
3. When maximum entry is exceeded, Style II will be supplied and dimensions F, G, H and J will not apply. Please consult factory.
4. Interface O-Ring not supplied with Connector Designator A.
5. When band option is selected adapters will be supplied with 601-040 Band. See Glenair Band-Master ATS Tool Catalog for installation details.
6. When polysulfide barrier is selected shield termination surface will be free of cadmium
7. Standard Boot Kit uses a straight lipped, type 1 material boot without adhesive. For additional material adhesive options order separately from section B
8. Glenair 600 series backshell assembly tools are recommended for assembly and installation
9. Recovered dimension apply to unrestricted recovery. Dimensions may differ than shown when boots are installed over assembly

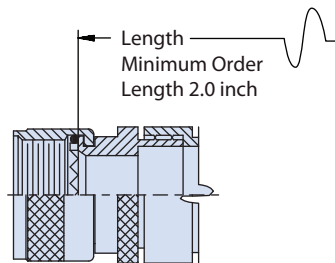

STYLE II
STRAIGHT (SYM S)
(See Note 3)

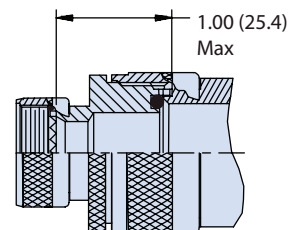

STYLE II
45° & 90°
(See Note 3)

G



SERIES 77
Metal Shrink Boot Adapters
M83723/27M
Series 310 Straight Adapter



Connector Designator:	
K	MIL-DTL-83723 Series II

How to Order			
Sample Part Number	M83723/27M	22	(M)
Basic Part Number	M83723/27M		
Shell Size Designator	see dimensions table		
Adapter	(M) = adapter only		

Order Boot Separately

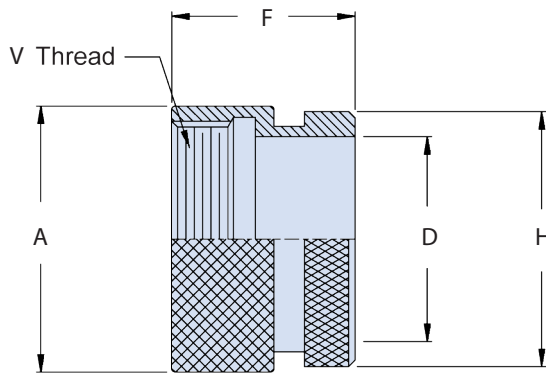

NOTES

1. For complete dimensions see the applicable Military Specification.
2. Finish: Electroless Nickel.
3. Recovered dimension apply to unrestricted recovery. Dimensions may differ than shown when boots are installed over assembly.

Dimensions						
Shell Size Designator	Shell Size Ref.	A Dia Max	D Dia	F Max	H (Min.)	V Thread Class 2B
08	8S	.577 (14.66)	.250 (6.35)	.830 (21.08)	.479 (12.17)	.438 - 28 UNEF
10	10S	.640 (16.26)	.303 (7.70)	.830 (21.08)	.539 (13.69)	.500 - 28 UNEF
11	10SL	.702 (17.83)	.383 (9.73)	.830 (21.08)	.608 (15.44)	.562 - 24 UNEF
12	12	.765 (19.43)	.408 (10.36)	.830 (21.08)	.659 (16.74)	.625 - 24 UNEF
13	12S	.765 (19.43)	.408 (10.36)	.830 (21.08)	.659 (16.74)	.625 - 24 UNEF
14	14	.890 (22.61)	.490 (12.45)	.830 (21.08)	.782 (19.86)	.750 - 20 UNEF
15	14S	.890 (22.61)	.490 (12.45)	.830 (21.08)	.782 (19.86)	.750 - 20 UNEF
16	16	1.015 (25.78)	.609 (15.47)	.830 (21.08)	.908 (23.06)	.875 - 20 UNEF
17	16S	1.015 (25.78)	.609 (15.47)	.830 (21.08)	.908 (23.06)	.875 - 20 UNEF
18	18	1.140 (28.96)	.730 (18.54)	.996 (25.29)	1.025 (26.03)	1.000 - 20 UNEF
20	20	1.265 (32.13)	.870 (22.10)	.996 (25.29)	1.212 (30.78)	1.125 - 18 UNEF
22	22	1.390 (35.31)	.978 (24.84)	.996 (25.29)	1.343 (34.11)	1.250 - 18 UNEF
24	24	1.515 (38.48)	1.090 (27.69)	.996 (25.29)	1.450 (36.83)	1.375 - 18 UNEF
28	28	1.765 (44.83)	1.250 (27.69)	1.076 (27.33)	1.671 (42.44)	1.625 - 18 UNEF
32	32	2.015 (51.81)	1.520 (38.61)	1.076 (27.33)	1.956 (49.68)	1.875 - 16 UN
36	36	2.265 (57.53)	1.756 (44.60)	1.076 (27.33)	2.164 (54.97)	2.125 - 16 UN
40	40	2.515 (63.88)	1.880 (47.75)	1.222 (31.04)	2.500 (63.50)	2.375 - 16 UN



SERIES 77
Metal Shrink Boot Adapters
AS85049/59
Series 310 Straight Adapter



Connector Designator:	
C	MIL-DTL-22992

How to Order			
Sample Part Number	M85049/59	A	10
Basic Part Number	M85049/59		
Finish	A = black anodize W = 500 hr. cadmium olive drab over electroless nickel		
Adapter Size	See dimensions table		

Order Boot Separately

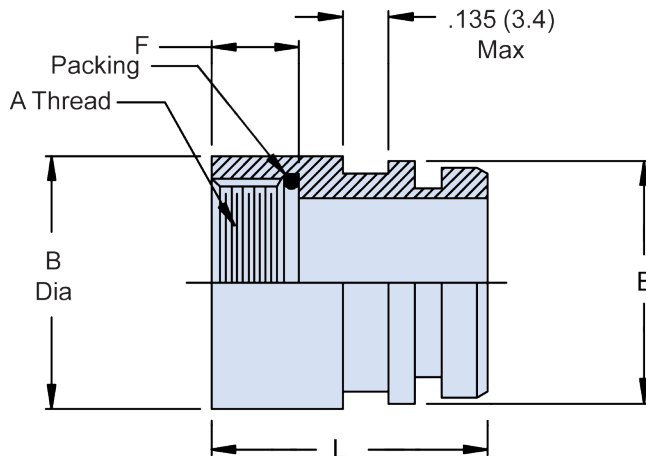

NOTES

1. For complete dimensions see the applicable Military Specification.
2. Recovered dimension apply to unrestricted recovery. Dimensions may differ than shown when boots are installed over assembly.

Dimensions					
Adapter Size	A Thread Class 2B-LH	B Max	F ±.016 (0.4)	L ±.031 (0.8)	E Dia ±.010 (0.3)
12	.7500 - 20 UNEF	.933 (23.70)	.479 (12.17)	1.175 (29.84)	.798 (20.27)
14	.8750 - 20 UNEF	1.057 (26.85)	.479 (12.17)	1.175 (29.84)	.922 (23.42)
16	1.000 - 20 UNEF	1.182 (26.85)	.479 (12.17)	1.175 (29.84)	1.048 (26.62)
18	1.125 - 18 UNEF	1.307 (33.20)	.479 (12.17)	1.175 (29.84)	1.172 (29.77)
20	1.250 - 18 UNEF	1.432 (36.37)	.479 (12.17)	1.175 (29.84)	1.297 (32.94)
22	1.375 - 18 UNEF	1.557 (39.55)	.479 (12.17)	1.175 (29.84)	1.423 (36.14)
24	1.625 - 18 UNEF	1.797 (45.64)	.479 (12.17)	1.175 (29.84)	1.662 (42.21)
28	1.875 - 16 UN	2.057 (52.25)	.479 (12.17)	1.175 (29.84)	1.922 (48.82)
32	2.0625 - 16 UN	2.307 (58.60)	.479 (12.17)	1.175 (29.84)	2.172 (55.17)
36	2.3125 - 16 UN	2.557 (64.95)	.479 (12.17)	1.175 (29.84)	2.422 (61.52)
40	2.6250 - 16 UN	2.869 (72.87)	.667 (16.94)	1.375 (34.92)	2.734 (69.44)
44	2.8750 - 16 UN	3.120 (79.25)	.667 (16.94)	1.375 (34.92)	2.982 (75.74)





SERIES 77 Metal Shrink Boot Adapters

AS85049/60-1 and MS3158 Series 310 Straight Adapter



Connector Designator:	
A	MIL-DTL-5015 Series 3400, MIL-DTL-26482 Series II, AS81703 Series III, MIL-DTL-83723 Series I & II, 40M39569, DEF 5326-3, EN 2997, EN 3646, ESC 10, ESC 11, LN 29504, NFC93422 Series HE302, PAN 6432-1, PAN 6432-2, PATT 602

How to Order			
Sample Part Number	M85049/60-1	W	10
Basic Part Number	M85049/60-1		
Finish	A = black anodize N = electroless nickel W = 500 hour cadmium olive drab over electroless nickel		
Dash Number	See dimensions table		

Order Boot Separately

Supersedes Part Numbers:
 MS3158-22A
 MS3158-22C
 MS3158-22N

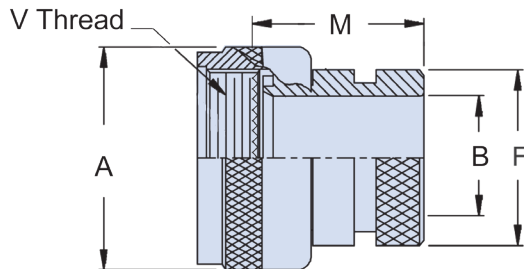

NOTES

1. For complete dimensions see the applicable Military Specification.
2. Recovered dimension apply to unrestricted recovery. Dimensions may differ than shown when boots are installed over assembly.

Dimensions					
Dash No	A Dia +.000 (0.0) -.045 (1.14)	B Min Dia	F Dia +.000 (0.0) -.020 (0.5)	M Max	V Thread
3	.669 (16.99)	.250 (6.35)	.533 (13.54)	.832 (21.13)	.562 - 24 UNEF
8	.617 (15.67)	.250 (6.35)	.533 (13.54)	.832 (21.13)	.500 - 20 UNF
10	.734 (18.64)	.355 (9.02)	.605 (15.37)	.832 (21.13)	.625 - 24 UNEF
12	.858 (21.79)	.491 (12.47)	.774 (19.66)	.832 (21.13)	.750 - 20 UNEF
14	.984 (24.99)	.565 (14.35)	.838 (21.29)	.832 (21.13)	.875 - 20 UNEF
16	1.112 (24.99)	.690 (17.53)	.963 (24.46)	.832 (21.13)	1.000 - 20 UNEF
18	1.218 (30.94)	.769 (19.53)	1.042 (26.47)	.832 (21.13)	1.062 - 18 UNEF
20	1.345 (34.16)	.894 (22.71)	1.217 (30.91)	.832 (21.13)	1.188 - 18 UNEF
22	1.468 (37.29)	1.019 (25.88)	1.355 (34.42)	.832 (21.13)	1.313 - 18 UNEF
24	1.593 (40.46)	1.134 (28.80)	1.443 (36.65)	.832 (21.13)	1.438 - 18 UNEF
28	1.969 (50.01)	1.369 (34.77)	1.709 (43.41)	.994 (25.25)	1.750 - 18 UNS
32	2.219 (56.36)	1.615 (41.02)	1.919 (48.74)	.994 (25.25)	2.000 - 18 UNS
36	2.469 (62.71)	1.830 (46.48)	2.169 (55.09)	.994 (25.25)	2.250 - 16 UN
40	2.719 (55.35)	2.045 (51.94)	2.402 (61.01)	.994 (25.25)	2.500 - 16 UN
44	2.969 (75.41)	2.300 (58.42)	2.657 (67.5)	.994 (25.25)	2.750 - 16 UN
48	3.219 (81.76)	2.550 (64.77)	2.907 (73.84)	.994 (25.25)	3.000 - 16 UN
61	1.653 (41.99)	1.174 (29.82)	1.529 (38.84)	.832 (21.13)	1.500 - 18 UNEF



SERIES 77 Metal Shrink Boot Adapters



M85049/60-2G and MS83416-G Series 310 Straight Adapter

Connector Designator:	
A	MIL-DTL-5015 Series 3400,
	MIL-DTL-26482 Series II,
	AS81703 Series III,
	MIL-DTL-83723 Series I & II,
	40M39569, DEF 5326-3,
	EN 2997, EN 3646, ESC 10,
	ESC 11, LN 29504,
	NFC93422 Series HE302,
	PAN 6432-1, PAN 6432-2,
	PATT 602

How to Order			
Sample Part Number	M85049/60-2G	10	W
Basic Part Number	M85049/60-2G		
Dash Number	See dimensions table		
Finish	A = black anodize N = electroless nickel W = 500 hour cadmium olive drab over electroless nickel		
			Order Boot Separately

Supersedes Part Numbers:
 MS3416-22GC
 MS3416-22GN

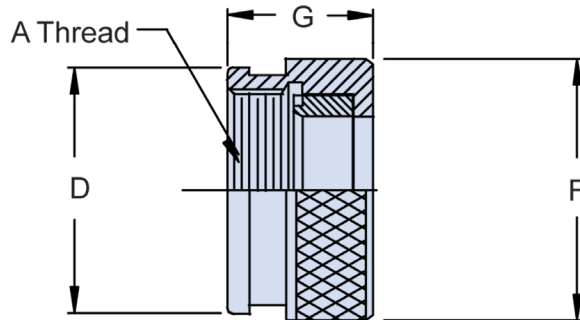

NOTES

- For complete dimensions see the applicable Military Specification.
- Recovered dimension apply to unrestricted recovery. Dimensions may differ than shown when boots are installed over assembly.

Dimensions				
Dash No	A Thread Class 2B	D Dia +.000 (0.0) -.020 (0.5)	F Dia +.000 (0.0) -.045 (1.1)	G Max
3	.562 - 24 UNEF	.709 (18.0)	.750 (19.1)	.540 (13.7)
8	.500 - 20 UNF	.657 (16.7)	.688 (17.5)	.540 (13.7)
10	.625 - 24 UNEF	.774 (19.7)	.803 (20.4)	.540 (13.7)
12	.750 - 20 UNEF	.898 (22.8)	.938 (23.8)	.540 (13.7)
14	.875 - 20 UNEF	1.024 (26.0)	1.063 (27.0)	.540 (13.7)
16	1.000 - 20 UNEF	1.152 (29.3)	1.238 (31.4)	.540 (13.7)
18	1.062 - 18 UNEF	1.243 (31.6)	1.310 (33.3)	.540 (13.7)
20	1.188 - 18 UNEF	1.370 (34.8)	1.436 (36.5)	.540 (13.7)
22	1.313 - 18 UNEF	1.443 (36.7)	1.560 (39.6)	.540 (13.7)
24	1.438 - 18 UNEF	1.618 (41.1)	1.686 (42.8)	.540 (13.7)
28	1.750 - 18 UNS	1.969 (50.0)	2.062 (52.4)	.702 (17.8)
32	2.000 - 18 UNS	2.219 (56.4)	2.312 (58.7)	.702 (17.8)
36	2.250 - 16 UN	2.469 (62.7)	2.562 (65.1)	.702 (17.8)
40	2.500 - 16 UN	2.719 (69.1)	2.812 (71.4)	.702 (17.8)
44	2.750 - 16 UN	2.969 (75.4)	3.062 (77.8)	.702 (17.8)
48	3.000 - 16 UN	3.219 (81.8)	3.312 (84.1)	.702 (17.8)
61	1.500 - 18 UNEF	1.653 (42.0)	1.748 (44.4)	.540 (13.7)





SERIES 77
Metal Shrink Boot Adapters
 AS85049/62 and MS38999/2
 Series 310 Straight Adapter



Connector Designator:	
F	MIL-DTL-38999 Series I & II, 40M38277, PAN 6433-1, PATT 614, PATT 616, NFC93422 Series HE308 & HE309

How to Order				
Sample Part Number	M85049/62	-10	W	D
Basic Part Number	M85049/62			
Dash No	see dimensions table			
Finish	A = black anodize N = electroless nickel W = 500 hour cadmium olive drab over electroless nickel			
Drain Hole	D = drain hole Omit for none			

Order Boot Separately

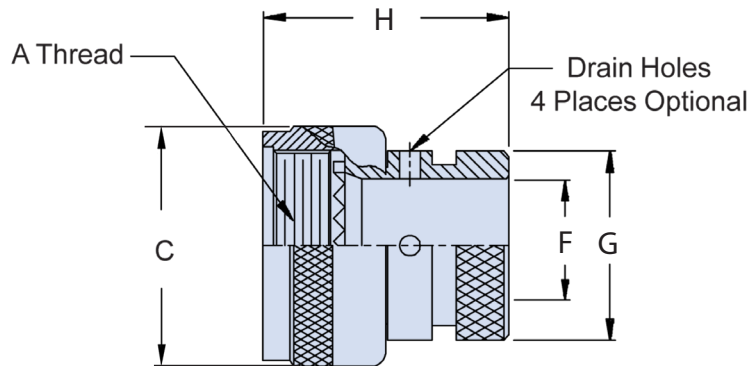

NOTES

1. For complete dimensions see the applicable Military Specification.
2. Recovered dimension apply to unrestricted recovery. Dimensions may differ than shown when boots are installed over assembly.
3. Recovered dimension apply to unrestricted recovery. Dimensions may differ than shown when boots are installed over assembly.

Dimensions					
Dash No.	A Thread Class 2B	C Max	F Dia Min	G Dia Max	H Max
08	.438 - 28 UNEF	.750 (19.1)	.250 (6.4)	.533 (13.5)	1.000 (25.4)
10	.562 - 24 UNEF	.850 (21.6)	.375 (9.5)	.605 (15.4)	1.000 (25.4)
12	.688 - 24 UNEF	1.000 (25.4)	.500 (12.7)	.774 (19.7)	1.000 (25.4)
14	.813 - 20 UNEF	1.100 (27.9)	.625 (15.9)	.838 (21.3)	1.000 (25.4)
16	.938 - 20 UNEF	1.250 (31.8)	.750 (19.1)	.963 (24.5)	1.000 (25.4)
18	1.063 - 18 UNEF	1.400 (35.6)	.812 (20.6)	1.042 (26.5)	1.000 (25.4)
20	1.188 - 18 UNEF	1.500 (38.1)	.937 (23.8)	1.217 (30.9)	1.000 (25.4)
22	1.313 - 18 UNEF	1.650 (41.9)	1.062 (27.0)	1.355 (34.4)	1.000 (25.4)
24	1.438 - 18 UNEF	1.750 (44.5)	1.188 (30.2)	1.443 (36.7)	1.000 (25.4)

G



SERIES 77
Metal Shrink Boot Adapters
AS85049/69
Series 310 Straight Adapter



Connector Designator:	
H	MIL-DTL-38999 Series III & IV, EN3645

How to Order				
Sample Part Number	M85049/69	-11	A	D
Basic Part Number	M85049/69			
Shell Size	see dimensions table			
Finish	A = black anodize N = electroless nickel W = 500 hour cadmium olive drab over electroless nickel			
Drain Hole	D = drain hole Omit for none			

Order Boot Separately

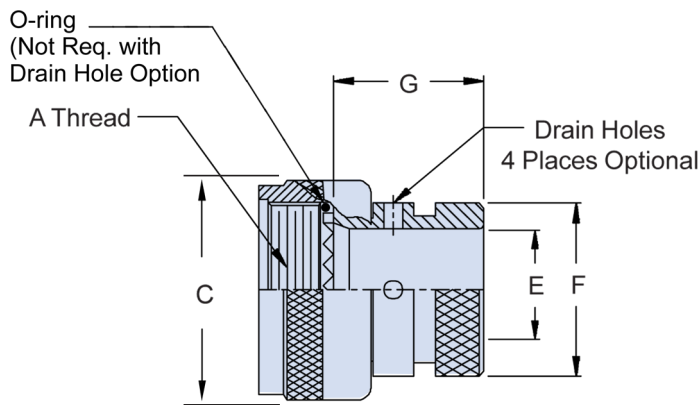

NOTES

1. For complete dimensions see the applicable Military Specification.
2. Recovered dimension apply to unrestricted recovery. Dimensions may differ than shown when boots are installed over assembly.

Dimensions					
Shell Size	A Thread Class 6H	C Max	E Dia Min	F Dia Max	G Max
9	M12 X 1 - 6H	.750 (19.05)	.250 (6.35)	.533 (13.5)	.710 (18.03)
11	M15 X 1 - 6H	.850 (21.59)	.375 (9.52)	.605 (15.4)	.710 (18.03)
13	M18 X 1 - 6H	1.000 (25.40)	.500 (12.70)	.774 (19.7)	.710 (18.03)
15	M22 X 1 - 6H	1.150 (29.21)	.625 (15.88)	.838 (21.3)	.710 (18.03)
17	M25 X 1 - 6H	1.250 (31.75)	.750 (19.05)	.963 (24.5)	.710 (18.03)
19	M28 X 1 - 6H	1.400 (35.56)	.812 (20.62)	1.042 (26.5)	.710 (18.03)
21	M31 X 1 - 6H	1.550 (39.37)	.937 (23.80)	1.217 (30.9)	.710 (18.03)
23	M34 X 1 - 6H	1.650 (41.91)	1.062 (26.97)	1.355 (34.4)	.710 (18.03)
25	M37 X 1 - 6H	1.885 (47.88)	1.188 (30.18)	1.443 (36.7)	.710 (18.03)





SERIES 77

Metal Shrink Boot Adapters



630-022 Straight, EMI/RFI Jam Nut, Front Mount or Flange Mount Environmental Bulkhead Feedthrough

How to Order	
Sample Part Number	630 A 022 M 16 B P T
Product Series	630
Fitting Type	A = rear mount B = front mount C = flange mount
Basic Part Number	022
Finish Symbol	B = cadmium plate, olive drab C = anodize, black G = hard coat, anodic M = electroless nickel NF = cadmium plate, olive drab over electroless nickel
Cable Entry Dash No.	See Dimensions table
Shield Termination	B = band K = precoiled Omit for none
Polysulfide Option	P = polysulfide Omit for none; see note 3
Shrink Boot	T = shrink boot; see cable entry and shrink boot table Omit for none



Add "T" to Part Number for Standard Boot

NOTES

1. Metric dimensions (mm) are in parentheses
2. When polysulfide barrier is selected shield termination surface will be free of cadmium
3. Standard Boot Kit uses a straight lipped,

type 1 material boot without adhesive. For additional material adhesive options order separately from section B

4. Recovered dimension apply to unrestricted recovery. Dimensions may differ than shown when boots are installed over assembly.

Dimensions									
Dash No.	Cable Entry Dia	A Thread Unified	B Dim	C Flat ± .010 ± (.3)	D Dia ± .010 ± (.3)	E Sq ± .031 ± (.8)	F Dim	G Dia +.005 (.1) -.015 (.4)	H Dia +.015 (.4) -0
02	.125 (3.18)	7/16 -28	.625 (15.88)	.418 (10.62)	.453 (11.51)	.812 (20.62)	.531 (13.49)	.438 (11.13)	.125 (3.2)
03	.188 (4.8)	1/2 -28	.688 (17.5)	.480 (12.2)	.515 (13.1)	.875 (22.2)	.594 (15.1)	.500 (12.7)	
04	.250 (6.4)	1/2 -28	.688 (17.5)	.480 (12.2)	.515 (13.1)	.875 (22.2)	.594 (15.1)	.500 (12.7)	
05	.313 (8.0)	5/8 -24	.813 (20.7)	.605 (15.4)	.640 (16.3)	1.000 (25.4)	.719 (18.3)	.625 (15.9)	
06	.375 (9.5)	5/8 -24	.813 (20.7)	.605 (15.4)	.640 (16.3)	1.000 (25.4)	.719 (18.3)	.625 (15.9)	
07	.438 (11.1)	3/4 -20	.938 (23.8)	.730 (18.5)	.765 (19.4)	1.094 (27.8)	.812 (20.6)	.750 (19.1)	
08	.500 (12.7)	3/4 -20	.938 (23.8)	.730 (18.5)	.765 (19.4)	1.094 (27.8)	.812 (20.6)	.750 (19.1)	
09	.563 (14.3)	7/8 -20	1.063 (27.0)	.855 (21.7)	.890 (22.6)	1.188 (30.2)	.906 (23.0)	.875 (22.2)	
10	.625 (15.9)	7/8 -20	1.063 (27.0)	.855 (21.7)	.890 (22.6)	1.188 (30.2)	.906 (23.0)	.875 (22.2)	
11	.688 (17.5)	1 -20	1.188 (30.2)	.980 (24.9)	1.015 (25.8)	1.281 (32.5)	.969 (24.6)	1.000 (25.4)	
12	.750 (19.1)	1 -20	1.188 (30.2)	.980 (24.9)	1.015 (25.8)	1.281 (32.5)	.969 (24.6)	1.000 (25.4)	
13	.813 (20.7)	1 1/8 -18	1.313 (33.4)	1.105 (28.1)	1.140 (29.0)	1.375 (34.9)	1.062 (27.0)	1.125 (28.6)	
14	.875 (22.2)	1 1/4 -18	1.438 (36.5)	1.230 (31.2)	1.265 (32.1)	1.500 (38.1)	1.156 (29.4)	1.250 (31.8)	
15	.938 (23.8)	1 1/4 -18	1.438 (36.5)	1.230 (31.2)	1.265 (32.1)	1.500 (38.1)	1.156 (29.4)	1.250 (31.8)	
16	1.000 (25.4)	1 3/8 -18	1.563 (39.7)	1.355 (34.4)	1.390 (35.3)	1.625 (41.3)	1.250 (31.8)	1.375 (34.9)	
17	1.063 (27.0)	1 3/8 -18	1.563 (39.7)	1.355 (34.4)	1.390 (35.3)	1.625 (41.3)	1.250 (31.8)	1.375 (34.9)	
18	1.125 (28.6)	1 1/2 -18	1.688 (42.9)	1.480 (37.6)	1.515 (38.5)	1.750 (44.5)	1.375 (34.9)	1.500 (38.1)	
19	1.188 (30.2)	1 1/2 -18	1.688 (42.9)	1.480 (37.6)	1.515 (38.5)	1.750 (44.5)	1.375 (34.9)	1.500 (38.1)	
20	1.250 (31.8)	1 5/8 -18	1.813 (46.1)	1.605 (40.8)	1.640 (41.7)	1.875 (47.6)	1.500 (38.1)	1.625 (41.3)	
22	1.375 (34.9)	1 3/4 -18	1.938 (49.2)	1.730 (43.9)	1.765 (44.8)	2.000 (50.8)	1.562 (39.7)	1.750 (44.5)	
24	1.500 (38.1)	2 -18	2.188 (55.6)	1.980 (50.3)	2.015 (51.2)	2.250 (57.2)	1.750 (44.5)	2.000 (50.8)	
26	1.625 (41.3)	2 -18	2.188 (55.6)	1.980 (50.3)	2.015 (51.2)	2.250 (57.2)	1.750 (44.5)	2.000 (50.8)	
28	1.750 (44.5)	2 1/4 -16	2.438 (61.9)	2.230 (56.6)	2.265 (57.5)	2.500 (63.5)	1.938 (49.2)	2.250 (57.2)	



SERIES 77
Metal Shrink Boot Adapters



630-022 Straight, EMI/RFI Jam Nut, Front Mount or Flange Mount Environmental Bulkhead Feedthrough

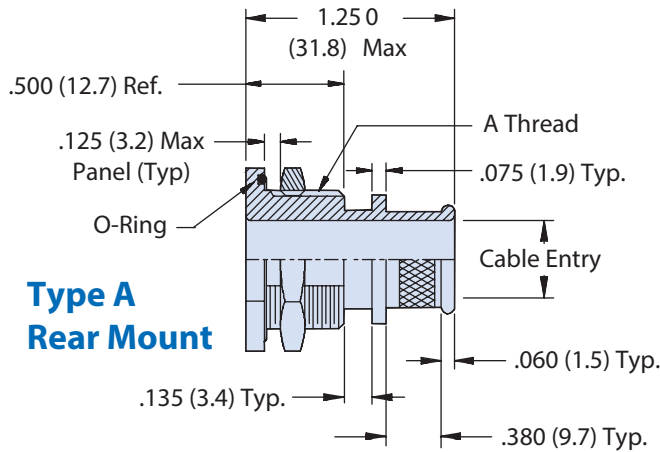
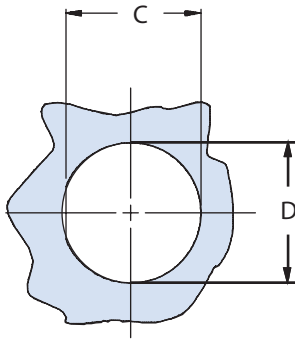

**Type A
Rear Mount**

Shrink Boot	
Dash No.	Shrink Boot
03-06	770-001S103
07-10	770-001S104
11-12	770-001S105
13-16	770-001S106
17-20	770-001S107
22-26	770-001S108
28	770-001S109

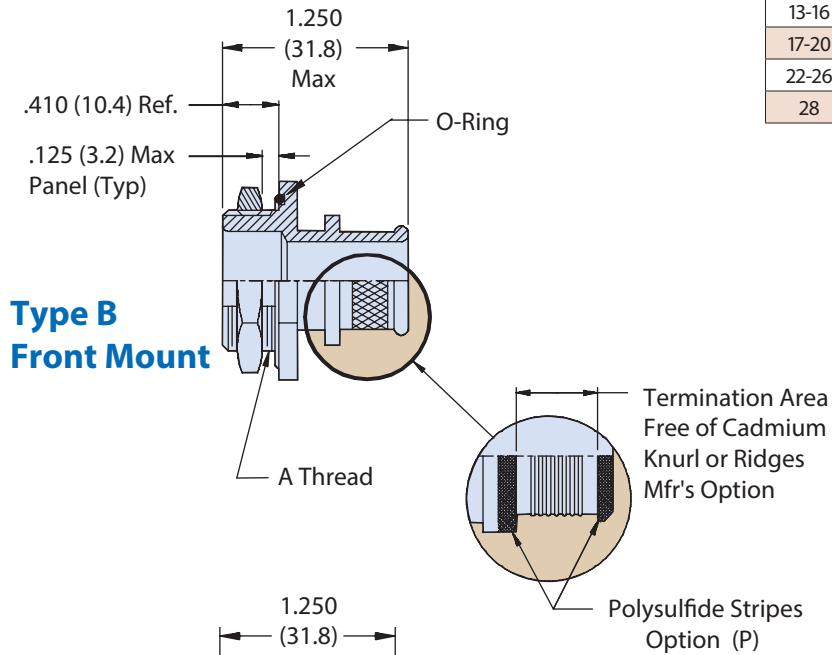
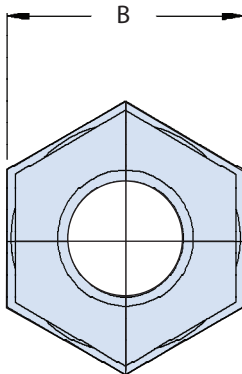

**Type B
Front Mount**

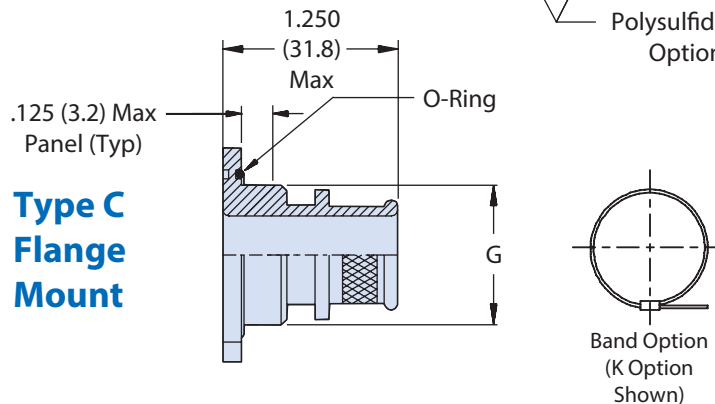
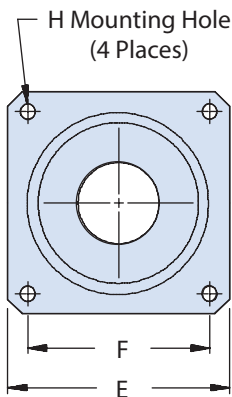

**Type C
Flange Mount**





SERIES 77 Composite Shrink Boot Adapters

Adapter Reference Guide Material and Finish



The following standard materials are used for the majority of Glenair's composite products. However, components are not limited to those listed but are representative of the elements used in Glenair's composite products.

Component	Material	Specification
Bodies and coupling nuts	Composite	AIR 4567, AS85049 ASTM D 5205
Elastomeric seals: Such as o-rings, cable jacket seals, grommets, etc.	Silicone or fluorosilicone	ZZ-R-765 or MIL-R-25988
Anti-decoupling device	Corrosion resistant material	N/A

Connector Designator Reference		
Designator	Specification	Series
A	MIL-DTL-5015	MS3400
	MIL-DTL-26482	2
	AS81703	3
	MIL-DTL-83723	I & III
	40M39569	
	DEF 5326-3	
	EN 2997, 3646	
	ESC 10, 11	
	LN 29504	
	NFC93422	HE302
F	PAN 6432-1, -2	
	PATT 602	
	MIL-DTL-38999	I & II
	40M38277	
	PAN 6433-1	
	PATT 614	
G	PATT 616	
	NFC93422	HE308, 9
H	MIL-C-28840	
	MIL-DTL-3899	III & IV
L	EN3645	
	EN3372	
	JN 1003	
	LN 29729	
	NFC93422	HE306
	PAN 6433-2	
	PATT 615	
VG 96912		
U	MIL-DTL-29600	

Composite Adapter Plating Codes	
Sym	Finish
XO	No Plating, Natural
XB	No Plating, Black
XM	Conductive, Electroless Nickel
XMT	Conductive, Ni-PTFE 1000 Hour Grey™
XW	Conductive, Cadmium O.D. Over Electroless Nickel
XZ	Conductive, Zinc Nickel, Black
XD	No Plating, Desert Tan

Composite Plating Code Cross-Reference		
Glenair Finish	MIL-DTL-38999	AS85049
XM	M	M
XW	J	J
XMT		XC

Locking Compound

Glenair recommends **ND VIBRA-TITE® Formula 3** Thread Locking Compound for customers who choose to lock or seal fasteners used on composite products.

Available from ND Industries (www.ndindustries.com), this product is non-reactive to composite resins

1000 Hour Grey™ Ni-PTFE Nickel Fluorocarbon Polymer



The MIL-DTL-38999 Rev L detail specification lists Nickel Fluorocarbon Polymer as a qualified cadmium free plating alternative. This RoHS compliant plating formula is now available on composite interconnect products from Glenair and offers the following benefits in harsh-environment applications:

- 2000+ hour salt spray
- Cadmium free
- Outstanding mating lubricity
- Hexavalent Chromium free
- 500+ mating cycles
- Non-Magnetic



SERIES 77

Composite Shrink Boot Adapters



Adapter Reference Guide

Table II - Connector Designator Interface Dimensions

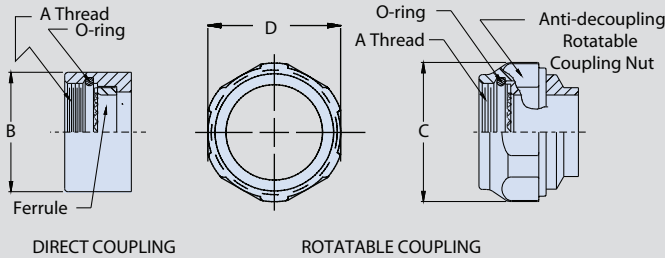

NOTES:

1. Connector shell size designations within [] are for reference only; do not use in part numbers.
2. Metric dimensions (mm) are in parentheses and are for reference only. (1 inch = 25.4 mm)
3. Consult factory for accessory interface data not listed.
4. Use Glenair 600-091 or 600-157 tool to tighten coupling nut. Rubber jaw pliers or strap wrench may damage the parts.

Table II								
Shell Size - Connector Designator					A Thread Ref	B Dia Max	C Dia Max	D Flats Ref
A	F/L	G	H	U				
-	08 [09]	-	-	-	7/16-28 UNEF	.59 (15.0)	.86 (21.8)	.75 (19.1)
-	-	-	09 [A]	-	M12 x 1 - 6H	.65 (16.5)		
08	-	-	-	-	1/2-20 UNF	.65 (16.5)	.98 (24.9)	.88 (22.2)
-	-	-	-	08 [9] [A] [B]	1/2-28 UNEF	.65 (16.5)		
03	10 [11]	-	-	-	9/16-24 UNEF	.72 (18.3)		
-	-	-	11 [B]	-	M15 x 1 - 6H	.77 (19.6)	1.16 (29.4)	1.00 (25.4)
10	-	-	-	-	5/8-24 UNEF	.77 (19.6)		
-	-	-	-	10 [11] [C] [D]	5/8-28 UN	.77 (19.6)	1.28 (32.5)	1.13 (28.6)
-	12 [13]	-	-	-	11/16-24 UNEF	.84 (21.3)		
-	-	-	13 [C]	-	M18 x 1 - 6H	.89 (22.6)		
12 [7]	-	11 [A]	-	-	3/4-20 UNEF	.91 (23.1)	1.41 (35.7)	1.25 (31.8)
-	-	-	-	12 [13] [F]	3/4-28 UNS	.91 (23.1)		
-	14 [15]	-	-	-	13/16-20 UNEF	.97 (24.6)	1.52 (38.5)	1.38 (35.1)
-	-	-	15 [D]	-	M22 x 1 - 6H	1.03 (26.2)		
14 [12]	-	13 [B]	-	-	7/8-20 UNEF	1.03 (26.2)		
-	-	-	-	[14] [15] [G] [H]	7/8-28 UN	1.03 (26.2)	1.64 (41.7)	1.50 (38.1)
-	16 [17]	-	-	-	15/16-20 UNEF	1.09 (27.7)		
-	-	-	17 [E]	-	M25 x 1 - 6H	1.15 (29.2)	1.77 (44.9)	1.63 (41.3)
16 [19]	-	15 [C]	-	-	1-20 UNEF	1.15 (29.2)		
-	-	-	-	16 [17] [J] [K]	1-28 UN	1.15 (29.2)		
18 [27]	18 [19]	-	-	-	1-1/16-18 UNEF	1.22 (31.0)	1.89 (48.0)	1.75 (44.5)
-	-	-	19 [F]	-	M28 x 1 - 6H	1.28 (32.5)		
-	-	17 [D]	-	-	1-1/8-18 UNEF	1.28 (32.5)	2.02 (51.2)	1.88 (47.6)
-	-	-	-	18 [19] [M] [N]	1-1/8-28 UN	1.28 (32.5)		
20 [37]	20 [21]	-	-	-	1-3/16-18 UNEF	1.34 (34.0)		
-	-	-	21 [G]	-	M31 x 1 - 6H	1.41 (35.8)	1.89 (48.0)	1.75 (44.5)
-	-	19 [E]	-	-	1-1/4-18 UNEF	1.41 (35.8)		
-	-	-	-	20 [21] [P] [R]	1-1/4-28 UN	1.41 (35.8)	1.77 (44.9)	1.63 (41.3)
22	22 [23]	-	-	-	1-5/16-18 UNEF	1.47 (37.3)		
-	-	-	23 [H]	-	M34 x 1 - 6H	1.53 (38.9)	1.89 (48.0)	1.75 (44.5)
-	-	-	-	22 [23] [S] [T]	1-3/8-28 UN	1.53 (38.9)		
24	24 [25]	23 [F]	-	-	1-7/16-18 UNEF	1.59 (40.4)	2.02 (51.2)	1.88 (47.6)
-	-	-	25 [J]	-	M37 x 1 - 6H	1.66 (42.2)		
61	-	-	-	-	1-1/2-18 UNEF	1.66 (42.2)	2.16 (54.8)	2.00 (50.8)
-	-	-	-	24 [25] [U] [M]	1-1/2-28 UN	1.66 (42.2)		
-	-	25 [G]	-	-	1-9/16-18 UNEF	1.66 (42.2)		
28	-	-	-	-	1-3/4-18 UNS	1.97(50.0)		





SERIES 77

Composite Shrink Boot Adapters



310-045 Composite Adapter with Self-Locking Rotatable Coupling Nut

How to Order	
Sample Part Number	310 F S 045 XM 16 D T
Product Series	310
Connector Designator	A, F, H
Angular Function	S = straight
Basic Part Number	045
Finish Symbol	XB = no plating - black color (non-conductive finish) XM = 2000 hour corrosion resistant electroless nickel XMT = 2000 hour corrosion resistant ni-ptfe, nickel-fluorocarbon polymer. 1000 Hour grey™ XW = 2000 hour corrosion resistant cadmium/olive drab over electroless nickel, 1000 hour salt spray XD = no plating, desert tan
Shell Size	See Dimensions Table
Drain Holes	D = drain holes Omit for none
Shrink Boot	T = shrink boot; see dimensions table Omit for none



Add "T" to Part Number for Standard Boot

Connector Designator	
A	MIL-DTL-5015, -26482 Series II, and -83723 Series I and III
F	MIL-DTL-38999 Series I, II
H	MIL-DTL-38999 Series III and IV
SELF-LOCKING	
ROTATABLE COUPLING	
STANDARD PROFILE	

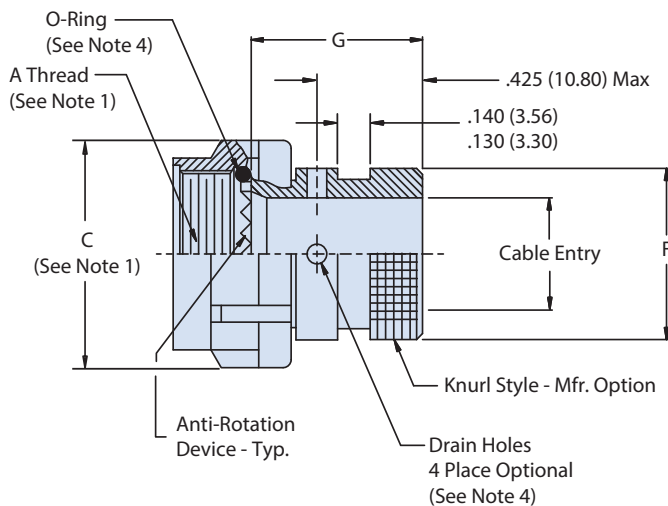

NOTES

- See Table II on G-29 for connector designator interface dimensions
- Assembly identified with manufacturer's name and P/N, space permitting.
- Glenair Series 600 adapter assembly tools are recommended for assembly and installation.
- O-Ring supplied with connector designator F and H only. O-Ring not supplied with connector designator A or with drain hole option.
- Standard Boot Kit uses a straight lipped, type 1 material boot without adhesive. For additional material adhesive options order separately from section B
- Recovered dimension apply to unrestricted recovery. Dimensions may differ than shown when boots are installed over assembly

Dimensions					
Shell Size		F Max	G Max	Cable Entry Min.	T Shrink Boot
A, F	H				
08	09	.533 (13.5)	.940 (23.9)	.250 (6.4)	770-001S102
10	11	.605 (15.4)	.940 (23.9)	.355 (9.0)	770-001S103
12	13	.774 (19.7)	.940 (23.9)	.491 (12.5)	770-001S103
14	15	.838 (21.3)	.940 (23.9)	.565 (14.4)	770-001S103
16	17	.963 (24.5)	.940 (23.9)	.690 (17.5)	770-001S104
18	19	1.042 (26.5)	.940 (23.9)	.769 (19.5)	770-001S104
20	21	1.217 (30.9)	.940 (23.9)	.894 (22.7)	770-001S106
22	23	1.355 (34.4)	.940 (23.9)	1.019 (25.9)	770-001S107
24	25	1.443 (36.7)	.940 (23.9)	1.134 (28.8)	770-001S107



SERIES 77

Composite Shrink Boot Adapters



310-017 Composite, Direct Coupling Adapter

How to Order							
Sample Part Number	310	F	S	017	XM	14	T
Product Series	310						
Connector Designator	A, F, H						
Angular Function	S = straight						
Basic Part Number	017						
Finish Symbol	XB = no plating - black color (non-conductive finish) XM = 2000 hour corrosion resistant electroless nickel XMT = 2000 hour corrosion resistant ni-ptfe, nickel-fluorocarbon polymer. 1000 hour grey™ XW = 2000 hour corrosion resistant cadmium/olive drab over electroless nickel, 1000 hour salt spray XD = no plating, desert tan						
Shell Size	see dimensions table						
Shrink Boot	T = shrink boot; see dimensions table Omit for none						



Add "T" to Part Number for Standard Boot

Connector Designator	
A	MIL-DTL-5015, -26482 Series II, and -83723 Series I and III
F	MIL-DTL-38999 Series I, II
H	MIL-DTL-38999 Series III and IV
DIRECT COUPLING	

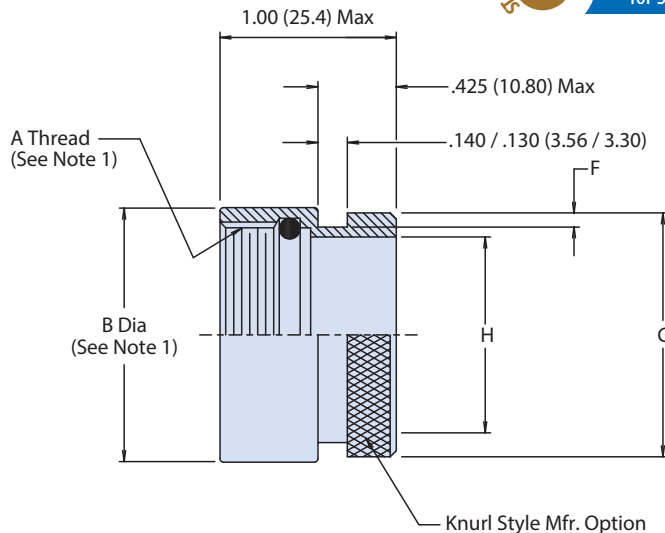

NOTES

- See Table II on G-29 for connector designator interface dimensions
- (Straight)** 770-001S**-0 shrink boot supplied with "T" option. For angled shrink boots, contact Glenair engineering. See shrink boot product pages for more details.
- Standard Boot Kit uses a straight lipped, type 1 material boot without adhesive. For additional material adhesive options order separately from section B
- Recovered dimension apply to unrestricted recovery. Dimensions may differ than shown when boots are installed over assembly

Shell Size		Dimensions			T Shrink Boot
A, F	H	F +.008 -.000	G +.000 -.045	H	
08	09	.044 (1.1)	.612 (15.5)	.346 (8.8)	770-001S103
10	11	.044 (1.1)	.764 (19.4)	.475 (12.1)	770-001S103
12	13	.044 (1.1)	.857 (21.8)	.589 (15.0)	770-001S104
14	15	.044 (1.1)	.980 (24.9)	.714 (18.1)	770-001S104
16	17	.044 (1.1)	1.100 (27.9)	.839 (21.3)	770-001S105
18	19	.069 (1.8)	1.215 (30.9)	.945 (24.0)	770-001S106
20	21	.069 (1.8)	1.345 (34.2)	1.070 (27.2)	770-001S107
22	23	.069 (1.8)	1.465 (37.2)	1.195 (30.4)	770-001S107
24	25	.069 (1.8)	1.590 (40.4)	1.320 (33.5)	770-001S107



SERIES 77

Composite Shrink Boot Adapters



380-132 Composite Environmental EMI/RFI Adapter for Knit Braid Style Shield Termination

Connector Designator:	
A	MIL-DTL-5015, -26482, Series II and -83723 Series I and III
F	MIL-DTL-38999 Series I, II
L	MIL-DTL-38999 Series 1.5 (JN1003)
H	MIL-DTL-38999 Series III and IV
ROTATABLE COUPLING	

NOTES

1. See Table II on G-29 for connector designator interface dimensions
2. For effective grounding connector with conductive finish should be used
3. Glenair 600 series adapter assembly tools are recommended for assembly and installation.
4. Consult factory for additional entry sizes
5. Accommodates knitmesh braid 107-044
6. Recovered dimension apply to unrestricted recovery. Dimensions may differ than shown when boots are installed over assembly

How to Order								
Sample Part Number	380	H	S	132	XM	15	-01	T
Product Series	380							
Connector Designator	A, F, L and H							
Angular Function	S = straight							
Basic Part Number	132							
Finish Symbol	See finish table							
Shell Size	See shell size table							
Cable Entry Code	See cable entry table							
Shrink Boot	SB = shrink boot groove option SBT = shrink boot groove with boot supplied Omit for none							

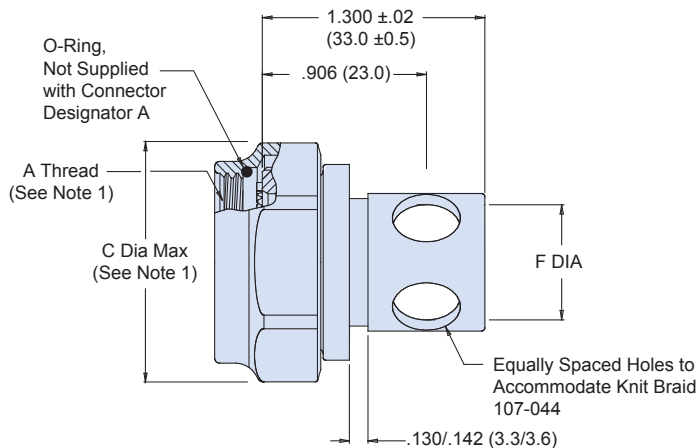

G

Finish	
Symbol	Finish Description
XM	2000 Hour Corrosion Resistant Electroless Nickel
XMT	2000 Hour Corrosion Resistant Ni-PTFE, Nickel-Fluorocarbon Polymer. <i>1000 Hour Grey™</i>
XW	2000 Hour Corrosion Resistant Cadmium/Olive Drab over Electroless Nickel

Cable Entry Code				
Shell Size A	Max Entry Code	Shell Size		Max Entry Code
		F/L	H	
08	00	08	09	01
10	01	10	11	02
12	02	12	13	03
14	03	14	15	04
16	04	16	17	05
18	05	18	19	06
20	06	20	21	07
22	07	22	23	08
24	08	24	25	09

Dimensions			
Entry Code	F ±.010 (0.25)	Number Of Holes	Shrink Boot
00	.268 (6.8)	2*	770-001S111
01	.354 (9.0)	2*	770-001S103
02	.472 (12.0)	2*	770-001S104
03	.591 (15.0)	2*	770-001S104
04	.709 (18.0)	2*	770-001S105
05	.837 (21.3)	2*	770-001S106
06	.945 (24.0)	2*	770-001S106
07	1.063 (27.0)	4*	770-001S107
08	1.191 (30.3)	4*	770-001S107
09	1.319 (33.56)	4*	770-001S108

- * Oval Holes, .256 (6.5) x .512 (13.0) Dia - 2 Off
- * 2 Oval Holes, .315 (8.0) x .512 (13.0) Dia - 2 Off
- * Circular Holes, .512 (13.0) Dia - 2 Off
- * Circular Holes .512 (13.0) Dia - 4 Off



SERIES 77

Composite Shrink Boot Adapters



440-144 Composite Ultra Low Profile EMI/RFI Adapter with Self-Locking Rotatable Coupling

Connector Designator	
A	MIL-DTL-5015, -26482, Series II and -83723 Series I and III
F	MIL-DTL-38999 Series I, II
H	MIL-DTL-38999 Series III and IV
SELF-LOCKING	
ROTATABLE COUPLING	
ULTRA LOW PROFILE	

Finish	
Symbol	Finish Description
XM	2000 Hour Corrosion Resistant Electroless Nickel
XMT	2000 Hour Corrosion Resistant Ni-PTFE, Nickel-Fluorocarbon Polymer. 1000 Hour Grey™
XW	2000 Hour Corrosion Resistant Cadmium/Olive Drab over Electroless Nickel

How to Order											
Sample Part Number	440	H	S	144	XM	15	09	D	B	T	S
Product Series	440										
Connector Designator	A, F and H										
Angular Function	S = straight T = 45° E = 90° A = 90° split W = 90° low profile										
Basic Part Number	144										
Finish Symbol	See finish table										
Shell Size	See dimensions table										
Cable Entry Code	See cable table (omit entry code for sym W & E)										
Drain Hole Option	D = drain hole Omit for none										
Band Option	B = micro-band K = pre-coiled micro-band Omit for none										
Shrink Boot	T = shrink boot Omit for none										
Shield Termination Slot	S = shield termination slot Omit for none (See Note 5)										

STANDARD BOOT KIT
 Add "T" to Part Number for Standard Boot

Cable Entry				
Entry Code	F ± .030	G ± .060	H ± .090	Shrink Boot
04	.250 (6.4)	.720 (18.3)	.870 (22.1)	770-003S102
05	.310 (7.9)	.750 (19.1)	.930 (23.6)	770-003S102
07	.440 (11.2)	.750 (19.1)	1.000 (25.4)	770-003S103
09	.560 (14.2)	.760 (19.3)	1.030 (26.2)	770-003S103
11	.680 (17.3)	.780 (19.8)	1.050 (26.7)	770-003S104
13	.810 (20.6)	.790 (20.1)	1.060 (26.9)	770-003S105
15	.940 (23.9)	.820 (20.8)	1.090 (27.7)	770-003S106
16	1.000 (25.4)	.860 (21.8)	1.130 (28.7)	770-003S106
17	1.160 (29.5)	.890 (22.6)	1.160 (29.5)	770-003S107

Dimensions									
Shell Size		Entry Code Available for Straight, 45° and 90° Std Configuration	J Max	K ±.03	L See Note 4	M See Note 4	N ±.09	P ±.09	R Max
A & F	H								
08	09	04	.630 (16.0)	1.042 (26.5)	.304 (7.7)	.160 (4.1)	.690 (17.5)	.880 (22.4)	1.360 (34.5)
10	11	05	.660 (16.8)	1.107 (28.1)	.432 (11.0)	.174 (4.4)	.750 (19.1)	1.000 (24.5)	1.420 (36.1)
12	13	07	.720 (18.3)	1.174 (29.8)	.546 (13.9)	.195 (5.0)	.810 (20.6)	1.130 (28.7)	1.480 (37.6)
14	15	09	.830 (21.1)	1.241 (31.5)	.670 (17.0)	.315 (8.0)	.880 (22.4)	1.310 (33.3)	1.550 (39.4)
16	17	05 and 11	.910 (23.1)	1.305 (33.1)	.796 (20.2)	.385 (9.8)	.940 (23.9)	1.380 (35.1)	1.610 (40.9)
18	19	07 and 13	.930 (23.6)	1.371 (34.8)	.902 (22.9)	.445 (11.3)	.970 (24.6)	1.440 (36.6)	1.640 (41.7)
20	21	09 and 15	1.040 (26.4)	1.438 (36.5)	1.027 (26.1)	.525 (13.3)	1.060 (26.9)	1.630 (41.4)	1.730 (43.9)
22	23	11 and 16	1.120 (28.4)	1.505 (38.2)	1.152 (29.3)	.595 (15.1)	1.130 (28.7)	1.750 (44.5)	1.800 (45.7)
24	25	07, 13 and 17	1.180 (30.0)	1.572 (39.9)	1.276 (32.4)	.655 (16.6)	1.190 (30.2)	1.880 (47.8)	1.860 (47.2)
24*	25			1.850 (47.0)	1.460 (37.1)	.450 (11.4)			

*See Note 7 Consult factory for shrink boot part numbers for elliptical parts



SERIES 77

Composite Shrink Boot Adapters



440-144 Composite Ultra Low Profile EMI/RFI Adapter with Self-Locking Rotatable Coupling

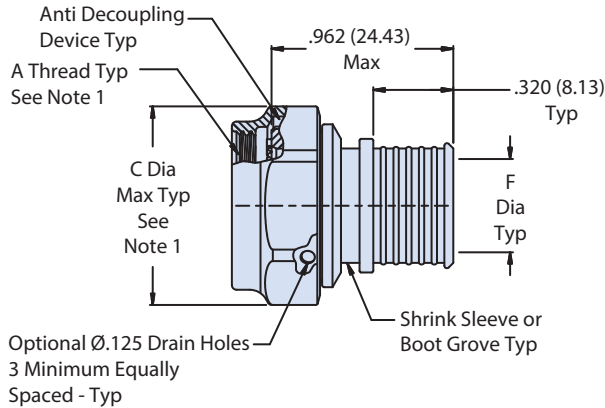

Sym S
Straight

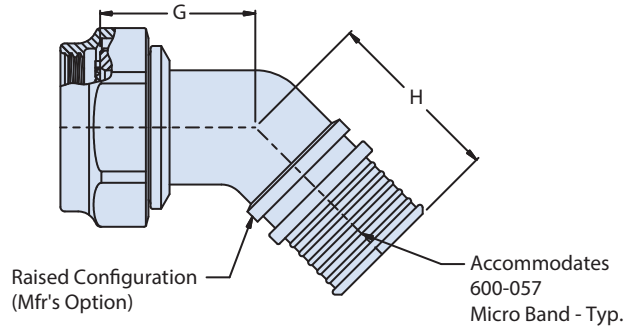

Sym T
45°

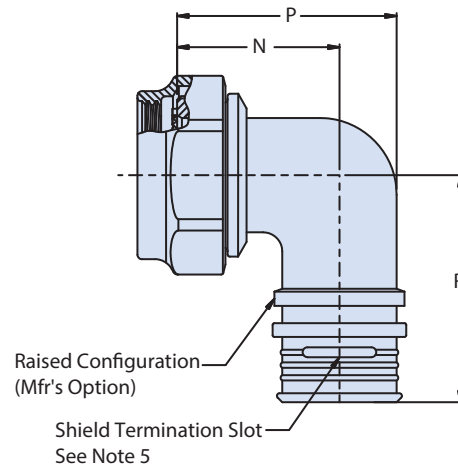
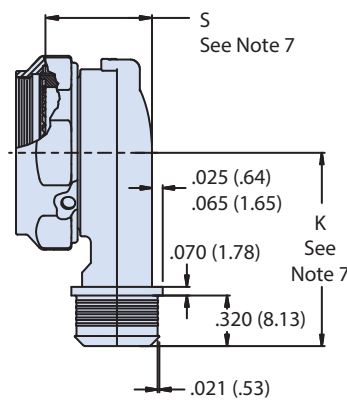
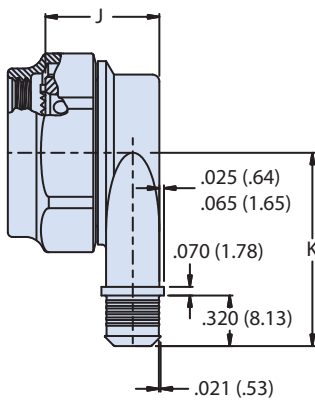

Sym A
90° - Std

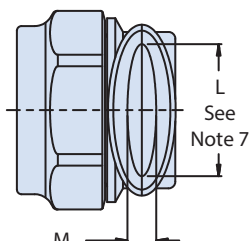
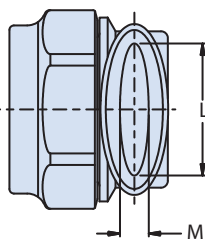

Sym W
90° - Low Profile
(Solid)

Sym E
90° - Low Profile
(Split)

NOTES

1. See Table II on G-29 for connector designator interface dimensions
2. 770-003S shrink boot supplied with T option. See shrink boot product pages for more details.
3. O-Ring will not be supplied with Connector Designator A.
4. Entry code is not used for angular function Sym W and E. Entry dimensions for these configurations are per shell size in dimensions table
5. A minimum of two shield termination slots will be supplied on adapters with exception to Sym 'E' which are supplied with one slot.
6. Standard Boot Kit uses a straight lipped, type 1 material boot without adhesive. Order separately for additional options
7. For Sym 'E' low profile split (SS 24/250 dimensions, use indicated row in dimensions table)
8. Recovered dimension apply to unrestricted recovery. Dimensions may differ than shown when boots are installed over assembly



SERIES 77

Composite Shrink Boot Adapters



447-325 Composite Standard Profile EMI/RFI Adapter with Self-Locking Rotatable Coupling

Connector Designator:	
A	MIL-DTL-5015, -26482 Series II, and -83723 Series I and III
F	MIL-DTL-38999 Series I, II
L	MIL-DTL-38999 Series 1.5 (JN1003)
H	MIL-DTL-38999 Series III and IV
G	MIL-DTL-28840
U	DG123 and DG123A
SELF-LOCKING	
ROTATABLE COUPLING	
STANDARD PROFILE	

Finish	
Symbol	Finish Description
XM	2000 Hour Corrosion Resistant Electroless Nickel
XMT	2000 Hour Corrosion Resistant Ni-PTFE, Nickel-Fluorocarbon Polymer. 1000 Hour Grey™
XW	2000 Hour Corrosion Resistant Cadmium/Olive Drab over Electroless Nickel

How to Order	
Sample Part Number	447 H S 325 XM 19 12 D K P T S
Product Series	447
Connector Designator	A, F, G, H, L and U
Angular Function	S = straight W = 90° elbow T = 45° elbow
Basic Part Number	325
Finish Symbol	See finish table
Shell Size	See dimensions table
Cable Entry Code	See cable entry table
Drain Hole Option	D = drain hole Omit for none
Band Option	B = std band K = pre-coiled std-band Omit for none
Polysulfide Option	P = polysulfide Omit for none
Shrink Boot Option	T = shrink boot and o-ring supplied O-ring not supplied with code A or F Omit for none
Shield Termination Slot	S = shield termination slot Omit for none



Add "T" to Part Number for Standard Boot

Dimensions										
Shell Size by Connector Designator*					90° Angle - Symbol T			45° Angle - Symbol W		Max Entry Dash No. **
A	F/L	H	G	U	E ± .06 (1.5)	F ± .09 (2.3)	G ± .09 (2.3)	H ± .06 (1.5)	J ± .09 (2.3)	
08	08	09	-	-	.69 (17.5)	.88 (22.4)	1.19 (30.2)	.72 (18.3)	1.00 (25.4)	04
10	10	11	-	08	.75 (19.1)	1.00 (25.4)	1.25 (31.8)	.75 (19.1)	1.06 (26.9)	06
12	12	13	11	10	.81 (20.6)	1.13 (28.7)	1.31 (33.3)	.75 (19.1)	1.13 (28.7)	08
14	14	15	13	12	.88 (22.4)	1.31 (33.3)	1.38 (35.1)	.76 (19.3)	1.16 (29.5)	10
16	16	17	15	14	.94 (23.9)	1.38 (35.1)	1.44 (36.6)	.78 (19.8)	1.18 (30.0)	12
18	18	19	17	16	.97 (24.6)	1.44 (36.6)	1.47 (37.3)	.79 (20.1)	1.19 (30.2)	13
20	20	21	19	18	1.06 (26.9)	1.63 (41.4)	1.56 (39.6)	.82 (20.8)	1.22 (31.0)	15
22	22	23	-	20	1.13 (28.7)	1.75 (44.5)	1.63 (41.4)	.86 (21.8)	1.26 (32.0)	17
24	24	25	23	22	1.19 (30.2)	1.88 (47.8)	1.69 (42.9)	.89 (22.6)	1.29 (32.8)	19
28	-	-	25	24	1.34 (34.0)	2.13 (54.1)	1.78 (45.2)	.92 (23.4)	1.32 (33.5)	22

*See Table II on G-29 for additional connector front-end details.

**Consult factory for additional entry sizes available

Cable Entry							
Entry Code	Cable Entry ± .03 (.08)	Entry Code	Cable Entry ± .03 (.08)	Entry Code	Cable Entry ± .03 (.08)	Entry Code	Cable Entry ± .03 (.08)
03	.19 (6.4)	08	.50 (20.6)	13	.81 (20.6)	18	1.13 (28.7)
04	.25 (7.9)	09	.56 (23.9)	14	.88 (22.4)	19	1.19 (30.2)
05	.31 (11.2)	10	.63 (25.4)	15	.94 (23.9)	20	1.25 (31.8)
06	.38 (14.2)	11	.69 (29.5)	16	1.00 (25.4)	22	1.38 (35.1)
07	.44 (17.3)	12	.75 (19.1)	17	1.06 (26.9)	--	--



SERIES 77

Composite Shrink Boot Adapters



447-325 Composite Standard Profile EMI/RFI Adapter with Self-Locking Rotatable Coupling

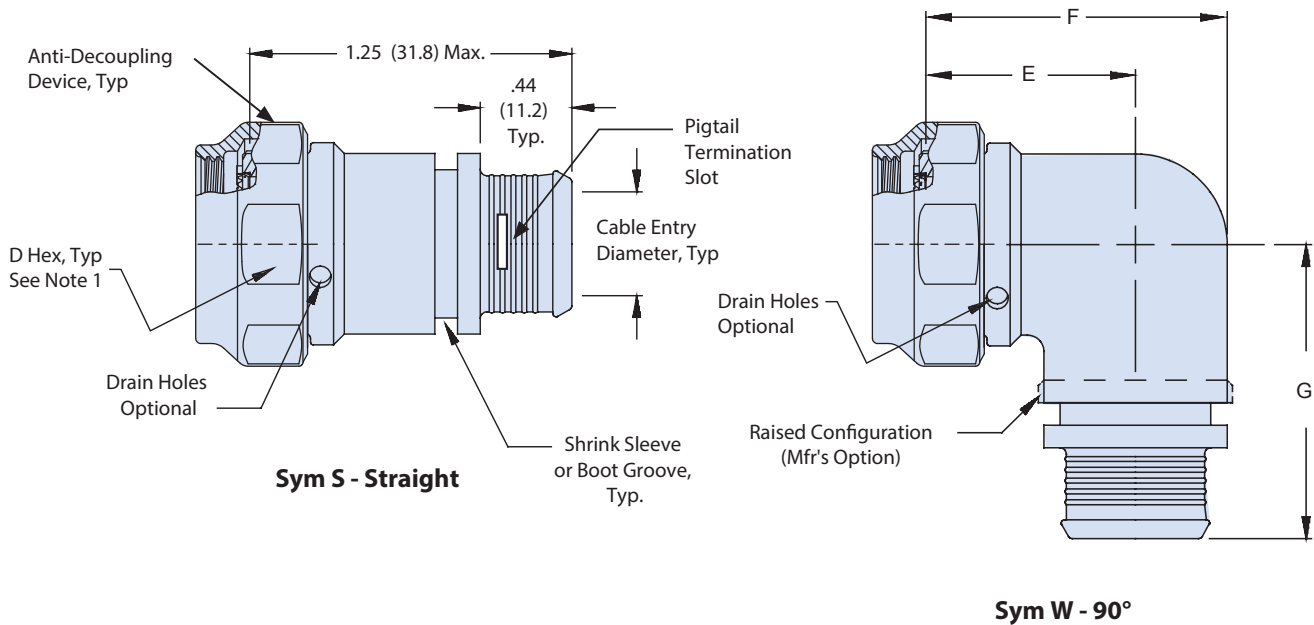

Sym S - Straight

Sym W - 90°

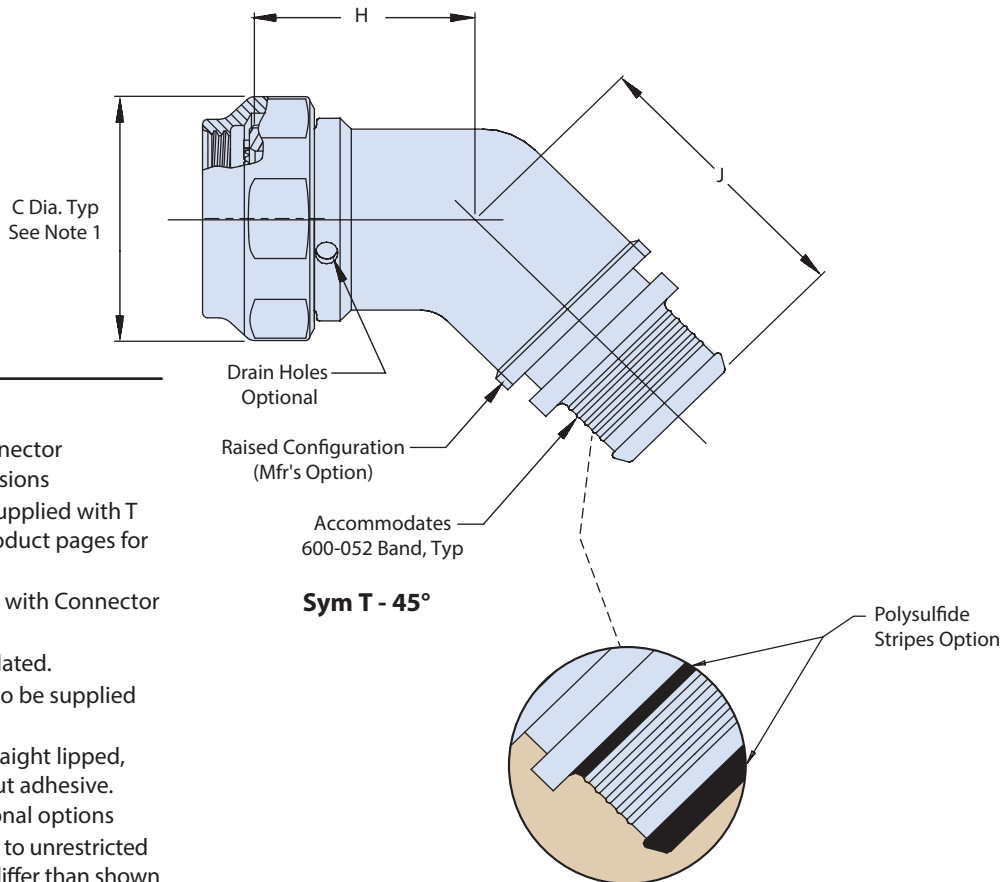

Sym T - 45°

G

NOTES

1. See Table II on G-29 for connector designator interface dimensions
2. 770-001S**-0 shrink boot supplied with T option. See shrink boot product pages for more details.
3. O-Ring will not be supplied with Connector Designator A and F.
4. Coupling nut supplied unplated.
5. Consult factory for O-Ring to be supplied with part less shrink boot.
6. Standard Boot Kit uses a straight lipped, type 1 material boot without adhesive. Order separately for additional options
7. Recovered dimension apply to unrestricted recovery. Dimensions may differ than shown when boots are installed over assembly

SERIES 77
PIGGYBACK
BOOTS



COMPOSITE AND METAL Piggyback shrink boot connector adapters

The recovery of shrink boots for environmental sealing and strain on all-land or air-vehicle interconnect cabling is a critical final step in the cable harness assembly process. This time-consuming task relies on each individual technician to correctly position and shrink boots on each of the many connectors found on the aircraft. Glenair composite or metal piggyback shrink boot connector adapters take all of the guesswork out of this time-consuming assembly task. Partially recovered boots, pre-attached to composite or metal adapters, take less than half the time to shrink in place, and are exactly pre-positioned for optimal sealing and strain relief each and every time the task is completed.

Light-weight and High Performance Offerings

Band-in-a-Can two-piece design provide the simplest cable shield termination solution



Cable bulk-head feed-thrus. Available for mated pairs also

Partially recovered shrink boot adapters cut down on installation time





SERIES 77

Piggyback Boot Adapters/Backshells

Product Selection Guide

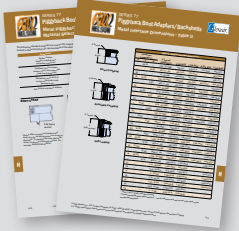

Metal Piggyback Boot Reference Guide

H-2

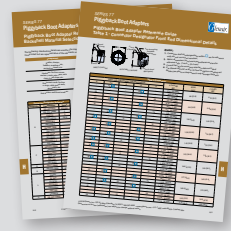

Composite Piggyback Boot Reference Guide

H-14



310-055
Metal, Environmental
Piggyback Boot Adapter

H-4



310-057
EMI/RFI Composite,
Environmental Piggyback
Boot Adapter with Drop-In
Banding Porch

H-16



310-058
EMI/RFI Metal Environmental
Piggyback Boot Adapter with
Drop-In Banding Porch

H-6



319-183
Composite Piggyback Boot
with integrated Shield Sock

H-18



319-216
EMI/RFI Metal Backshell with
Shielded Piggyback Boot

H-8



443-033
EMI/RFI Composite Band-in-a-
Can Backshell and Piggyback
Boot

H-20



443-040
EMI/RFI Metal
Band-in-a-Can Backshell
with Self Locking Rotatable
Coupling and Piggyback Boot

H-10



630-103
Composite Environmental
Cable Feed-thru with
Piggyback Boot

H-22



630-101
Metal Environmental Cable
Feed-Thru with Piggyback
Boot

H-12





SERIES 77

Piggyback Boot Adapters/Backshells



Metal Piggyback Boot Reference Guide Material Selection and Finish

The following standard materials are used for the majority of Glenair's metal adapter/backshell products. However, components are not limited to those listed but are representative of the elements used in Glenair's metal adapter/backshell products.

Component	Material	Specification
Bodies, clamps, Saddles, coupling nuts, protective covers, etc.	Aluminum Alloy	AMS-QQ-A-200, AMS-QQ-A-591, ASTM B209, ASTM B221, ASTM B85
Hardware: Such as screws, washers, rivets, wire rope, sash chain, band straps, etc.	Corrosion Resisting Steel	AMS-QQ-S-763, AMS-QQ-S-764, ASTM A276
Elastomeric seals: Such as o-rings, cable jacket seals, grommets, etc.	Silicone	A-A-59588, AMS-3303, AMS-3304

Metal Plating Codes	
Sym	Finish
M	Electroless nickel
MT	electroless nickel-PTFE
NF	Cadmium/O.D. over electroless nickel (500 hours salt spray)
ZR	Zinc-nickel, black over electroless nickel
NFS	Selectively plated cadmium O.D. over E.N.

Metal Plating Code Cross-Reference		
Glenair Finish	MIL-DTL-38999	AS85049
M	-	G, N
MT	T	X
NF	W	W
ZR	Z	Z
NFS	-	P

Connector Designator Reference		
Designator	Specification	Series
A	MIL-DTL-5015	MS3400
	MIL-DTL-26482	2
	AS81703	3
	MIL-DTL-83723	I & III
	40M39569	
	DEF 5326-3	
	EN 2997, 3646	
	ESC 10, 11	
	LN 29504	
	NFC93422	HE302
	PAN 6432-1, -2	
PATT 602		
F	MIL-DTL-38999	I & II
	40M38277	
	PAN 6433-1	
	PATT 614	
	PATT 616	
	NFC93422	HE308, 9
H	MIL-DTL-38999	III & IV
	EN3645	

H



SERIES 77

Piggyback Boot Adapters/Backshells



Metal Piggyback Boot Reference Guide

Table I - Connector Designator Interface Dimensions

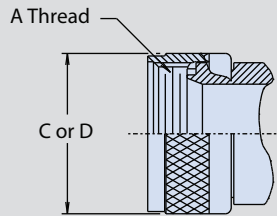

Rotatable Coupling

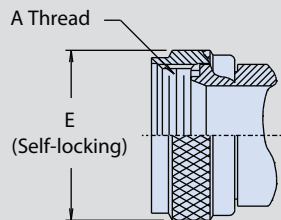

Self-Locking

Table I - Connector Designator Interface Dimensions							
Connector Designator**			A Thread*	B DIA MAX	C DIA MAX	D DIA MAX	E DIA MAX
A	F	H	REFERENCE				
--	08 [9]	--	7/16 - 28 UNEF	.590 (15.)	.650 (16.5)	.770 (19.6)	.690 (17.5)
--	--	09 [A]	M12 x 1 - 6H	.650 (16.5)	.770 (19.6)	--	.940 (24.8)
08	--	--	1/2 - 20 UNF	.650 (16.5)	.650 (16.5)	--	.690 (17.5)
03	10 [11]	--	9/16 - 24 UNEF	.720 (18.3)	.770 (19.6)	.890 (22.6)	.820 (20.8)
--	--	11 [B]	M15 x 1 - 6H	.770 (19.6)	.820 (20.8)	--	1.060 (26.9)
10	--	--	5/8 - 24 UNEF	.770 (19.6)	.770 (19.6)	.890 (22.6)	.820 (20.8)
--	12 [13]	--	11/16 - 24 UNEF	.840 (21.3)	.890 (22.6)	1.020 (25.9)	.940 (23.8)
--	--	13 [C]	M18 x 1 - 6H	.890 (22.6)	.940 (23.9)	--	1.170 (29.7)
[7]	--	--	3/4 - 20 UNEF	.970 (24.6)	.940 (23.9)	1.020 (25.9)	.940 (23.8)
--	14 [15]	--	13/16 - 20 UNEF	.970 (24.6)	1.020 (29.2)	1.150 (29.2)	1.060 (26.9)
--	--	15 [D]	M22 x 1 - 6H	1.030 (26.2)	1.070 (26.2)	--	1.290 (32.7)
[12]	--	--	7/8 - 20 UNEF	1.090 (27.7)	1.020 (25.9)	1.150 (29.2)	1.060 (26.9)
--	16 [17]	--	15/16 - 20 UNEF	1.090 (27.7)	1.150 (29.2)	1.260 (32.0)	1.170 (29.7)
--	--	17 [E]	M25 x 1 - 6H	1.150 (29.2)	1.210 (30.7)	--	1.420 (36.1)
[19]	--	--	1 - 20 UNEF	1.220 (29.2)	1.210 (30.7)	1.230 (31.2)	1.170 (29.7)
[27]	18 [19]	--	11/16 - 18 UNEF	1.220 (31.0)	1.230 (31.2)	1.400 (35.6)	1.290 (32.7)
--	--	19 [F]	M28 x 1 - 6H	1.280 (32.5)	1.360 (34.5)	--	1.540 (39.1)
[37]	20 [21]	--	13/16 - 18 UNEF	1.340 (34.0)	1.360 (34.5)	1.530 (38.9)	1.420 (36.0)
--	--	21 [G]	M31 x 1 - 6H	1.410 (35.8)	1.480 (37.6)	--	1.670 (42.4)
22	22 [23]	--	15/16 - 18 UNEF	1.470 (37.3)	1.480 (37.6)	1.600 (40.6)	1.540 (39.1)
--	--	23 [H]	M34 x 1 - 6H	1.530 (38.9)	1.600 (40.6)	--	2.010 (51.1)
24	24 [25]	--	17/16 - 18 UNEF	1.590 (40.4)	1.730 (43.9)	1.940 (49.3)	1.660 (42.2)
--	--	25 [J]	M37 x 1 - 6H	1.660 (42.2)	1.700 (43.2)	--	2.120 (53.8)
61	--	--	1 1/2 - 18 UNEF	1.660 (42.2)	1.670 (42.4)	--	--
28	--	--	1 3/4 - 18 UNS	1.970 (50.0)	1.970 (50.0)	--	2.010 (51.1)
32	--	--	2 - 18 UNS	2.280 (57.9)	2.220 (56.4)	--	2.260 (57.4)
36	--	--	2 1/4 - 16 UN	2.530 (64.3)	2.47 (62.7)	--	2.530 (64.3)
40	--	--	2 1/2 - 16 UN	2.780 (70.6)	2.720 (69.1)	--	3.040 (77.2)
44	--	--	2 3/4 - 16 UN	3.030 (77.0)	2.970 (75.4)	--	--
48	--	--	3 - 16 UN	3.220 (81.8)	3.220 (81.8)	--	--

**Connector designations depicted thus [] are for reference only and are not to be used in part number development.





SERIES 77

Piggyback Boot Adapters/Backshells



310-055 Metal Adapter for MIL-DTL-38999 and MIL-DTL-5015 - How to Order

How to Order							
Sample Part Number	310	F	S	055	NF	16	2
Product Series	310 = Metal piggyback boot adapter						
Connector Designator	A = MIL-DTL-83723, Series 3 F = MIL-DTL-38999, Series I & II H = MIL-DTL-38999, Series III & IV						
Angular Function	S = Straight						
Basic Number	055						
Finish Symbol	M = Electroless nickel MT = Nickel-PTFE NF = Cadmium/O.D. over electroless nickel (500 hours salt spray) ZR = Zinc-nickel, black over electroless nickel						
Shell Size	See dimensions table						
Boot Material	1 = Type 1 2 = Type 2 3 = Type 3; see boot material table						

Boot Material Selection Guide			
Attribute	Type 1	Type 2	Type 3
	High-Performance Semi-Rigid Elastomer	Zero-Halogen Semi-Rigid Polyolefin	General Purpose Flexible Polyolefin
Continuous Operating Temp.	-75° to +150° c	-40° to +130° c	-55° to +135° c
Resistance To Fuels, Oils	Excellent	Very Good	Good
Low Toxicity, Zero Halogen	No	Yes	No

NOTES

- See Table I on Page H-3 for connector designator interface dimensions
- Glenair 600 series backshell assembly tools are recommended for assembly and installation.
- O-ring supplied with connector designator F and H only. O-ring not supplied with connector designator A
- Recovered dimension apply to unrestricted recovery. Dimensions may differ than shown when boots are installed over assembly.

Material and Finish

- Adapters, and coupling nut: aluminum alloy/see how-to-order table for finish
- Shrink boot: elastomeric/N.A.
- O-ring: silicone/N.A.
- Anti-rotational device: corrosion resistant material

H



SERIES 77

Piggyback Boot Adapters/Backshells



310-055 Metal Adapter for MIL-DTL-38999 and MIL-DTL-5015 - Dimensions

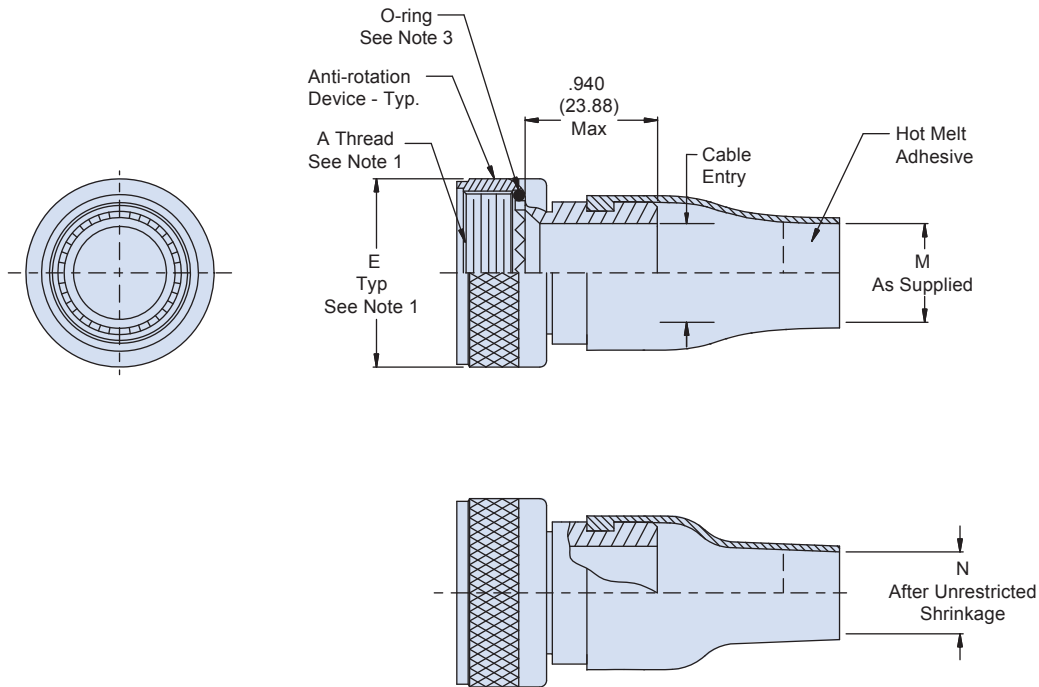

Dimensions				
Shell Size by Connector Designator		Cable Entry Min	M Min	N Max
A, F	H			
08	09	.250 (6.4)	.250 (6.4)	.197 (5.00)
10	11	.355 (9.0)	.355 (9.0)	.197 (5.00)
12	13	.491 (12.5)	.491 (12.5)	.236 (6.00)
14	15	.565 (14.4)	.565 (14.4)	.236 (6.00)
16	17	.690 (17.5)	.690 (17.5)	.276 (7.01)
18	19	.769 (19.5)	.769 (19.5)	.335 (8.51)
20	21	.894 (22.7)	.894 (22.7)	.394 (10.0)
22	23	1.019 (25.9)	1.019 (25.9)	.394 (10.0)
24	25	1.134 (28.8)	1.134 (28.8)	.591 (15.0)





SERIES 77

Piggyback Boot Adapters/Backshells



310-058 EMI/RFI Metal Adapter with Drop-In Band Adapter and Preinstalled Shrink Boot - How to Order

How to Order	
Sample Part Number	310 F S 058 NF 16 -2 K
Product Series	310 = Metal piggyback boot adapter
Connector Designator	A = MIL-DTL-83723, Series III F = MIL-DTL-38999, Series I & II H = MIL-DTL-38999, Series III & IV
Angular Function	S = Straight A = 90° B = 45°
Basic Number	058
Finish Symbol	M = Electroless nickel MT = Nickel-PTFE NF = Cadmium/O.D. over electroless nickel (500 hours salt spray) ZR = Zinc-nickel, black over electroless nickel NFS = Selectively plated cadmium O.D. over E.N.
Shell Size	See dimensions table
Boot Material	1 = Type 1 2 = Type 2 3 = Type 3; see boot material table
Band	K = Pre-coiled micro band Omit if not required



Boot Material Selection Guide			
Attribute	Type 1	Type 2	Type 3
	High-Performance Semi-Rigid Elastomer	Zero-Halogen Semi-Rigid Polyolefin	General Purpose Flexible Polyolefin
Continuous Operating Temp.	-75° to +150° c	-40° to +130° c	-55° to +135° c
Resistance To Fuels, Oils	Excellent	Very Good	Good
Low Toxicity, Zero Halogen	No	Yes	No

NOTES

1. See Table I on Page H-3 for connector designator interface dimensions.
2. Glenair 601-101 micro banding tool is recommended
3. Recovered dimension apply to unrestricted recovery. Dimensions may differ than shown when boots are installed over assembly.

Material and Finish

- Adapters, and coupling nut: aluminum alloy/see how to order table
- Shrink boot: elastomeric/N.A.
- O-ring: silicone/N.A.
- Anti-rotational device: corrosion resistant material

H



SERIES 77

Piggyback Boot Adapters/Backshells



310-058 EMI/RFI Metal Adapter with Drop-In Band Adapter and Preinstalled Shrink Boot - Dimensions

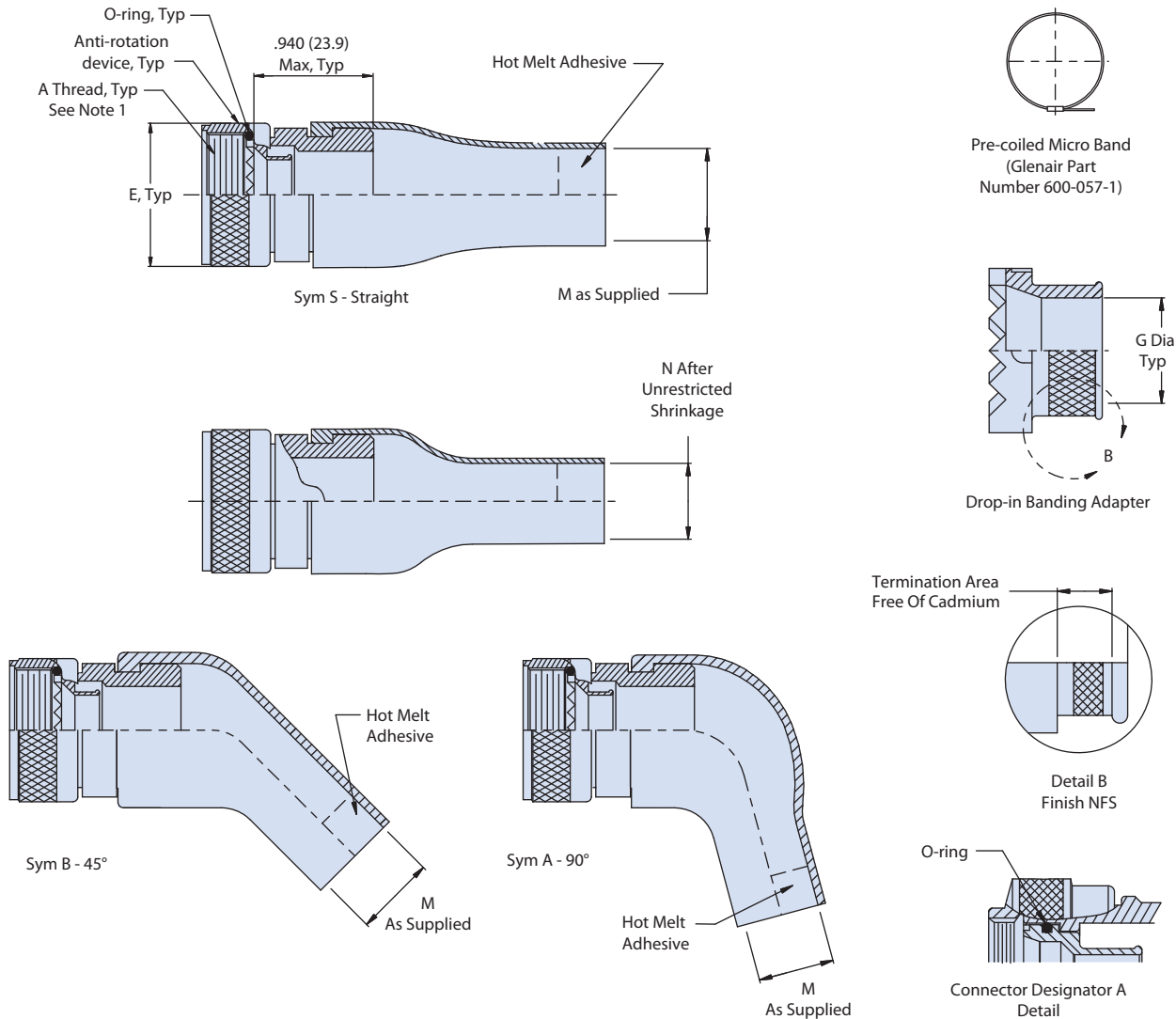

Dimensions								
Conn. Desig. A		Conn. Desig. F		Conn. Desig. H		E DIA MAX	M MIN	N MAX
Shell Size	G Dia.	Shell Size	G Dia	Shell Size	G Dia			
08	.160 (4.06)	08	.138 (3.51)	09	.160 (4.06)	0.94 (23.88)	.250 (6.4)	.197 (5.00)
10	.270 (6.86)	10	.248 (6.30)	11	.270 (6.86)	1.06 (26.92)	.355 (9.0)	.197 (5.00)
12	.390 (9.91)	12	.375 (9.52)	13	.390 (9.91)	1.17 (29.72)	.491 (12.5)	.236 (6.00)
14	.512 (13.00)	14	.455 (11.56)	15	.512 (13.00)	1.29 (32.77)	.565 (14.4)	.236 (6.00)
16	.610 (15.49)	16	.577 (14.66)	17	.627 (15.93)	1.42 (36.07)	.690 (17.5)	.276 (7.01)
18	.672 (17.07)	18	.672 (17.07)	19	.747 (18.97)	1.54 (39.12)	.769 (19.5)	.335 (8.51)
20	.797 (20.24)	20	.797 (20.24)	21	.891 (22.63)	1.67 (42.42)	.894 (22.7)	.394 (10.0)
22	.922 (23.42)	22	.922 (23.42)	23	.996 (25.30)	2.01 (51.05)	1.019 (25.9)	.394 (10.0)
24	1.047 (26.59)	24	1.047 (26.59)	25	1.121 (28.47)	2.12 (53.85)	1.134 (28.8)	.591 (15.0)





SERIES 77

Piggyback Boot Adapters/Backshells



319-216 EMI/RFI Metal Backshell with Pre-installed Shield and Shrink Boot - How to Order

How to Order	
Sample Part Number	319 H S 216 NF 19 06 B 2 -4
Product Series	319 = backshell
Connector Designator	A = MIL-DTL-83723, Series III F = MIL-DTL-38999, Series I & II H = MIL-DTL-38999, Series III & IV
Angular Function	S = Straight H = 45° J = 90°
Basic Number	216
Finish Symbol	M = Electroless nickel MT = Nickel-PTFE NF = Cadmium/O.D. over electroless nickel (500 hours salt spray) ZR = Zinc-nickel, black over electroless nickel
Shell Size	See dimensions table
Dash Number	See dash number table
Braid Option	See braid table
Boot Material	1 = Type 1 2 = Type 2 3 = Type 3; see boot material table
Length (S Only)	1/2 inch increments: e.g. 4 = 2 inches; Minimum order length is 1.5 inches for style I and 2.0 inches for style II

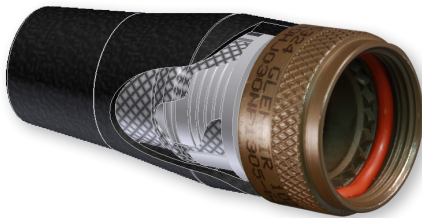

Boot Material Selection Guide			
Attribute	Type 1	Type 2	Type 3
	High-Performance Semi-Rigid Elastomer	Zero-Halogen Semi-Rigid Polyolefin	General Purpose Flexible Polyolefin
Continuous Operating Temp.	-75° to +150° c	-40° to +130° c	-55° to +135° c
Resistance To Fuels, Oils	Excellent	Very Good	Good
Low Toxicity, Zero Halogen	No	Yes	No

Braid	
Symbol	Braid Type
A	100% AmberStrand®
B	75%/25% AmberStrand® Blend
-	Nickel/Copper 34 AWG
T	Tin/Copper 34 AWG
L	Armorlite™

Dash Number				
Dash No.	Cable Entry	L Max	M Min	N Max
03	.188 (4.78)	.693 (17.60)	.188 (4.78)	.079 (2.01)
04	.250 (6.35)	1.082 (27.48)	.250 (6.35)	.118 (3.00)
05	.312 (7.92)	1.646 (41.81)	.312 (7.92)	.197 (5.00)
06	.375 (9.52)	1.646 (41.81)	.375 (9.52)	.197 (5.00)
07	.438 (11.13)	1.646 (41.81)	.438 (11.13)	.197 (5.00)
08	.500 (12.70)	2.382 (60.50)	.500 (12.70)	.236 (5.99)
10	.625 (15.88)	2.382 (60.50)	.625 (15.88)	.236 (5.99)
12	.750 (19.05)	2.902 (73.71)	.750 (19.05)	.276 (7.01)
14	.875 (22.23)	3.465 (88.01)	.875 (22.23)	.335 (8.51)
16	1.000 (25.40)	3.465 (88.01)	1.000 (25.40)	.335 (8.51)
18	1.125 (28.58)	3.464 (87.99)	1.125 (28.58)	.335 (8.51)
20	1.250 (31.75)	4.288 (108.92)	1.250 (31.75)	.394 (10.01)
24	1.500 (38.10)	4.288 (108.92)	1.500 (38.10)	.394 (10.01)
28	1.750 (44.45)	5.630 (143.00)	1.750 (44.45)	.591 (15.01)
32	2.000 (50.80)	5.630 (143.00)	2.000 (50.80)	.591 (15.01)



SERIES 77

Piggyback Boot Adapters/Backshells



319-216 EMI/RFI Metal Backshell with Pre-installed Shield and Shrink Boot - Dimensions

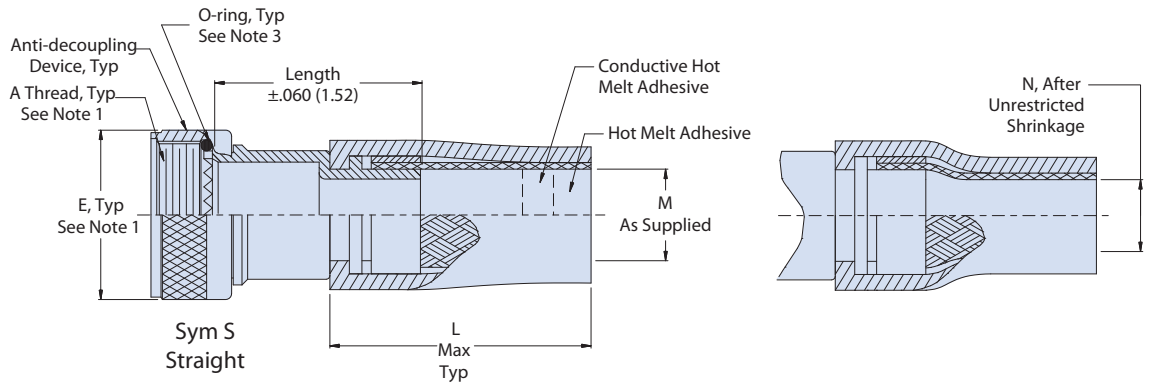

NOTES

1. See Table I on Page H-3 for connector designator interface dimensions
2. Glenair 600 series backshell assembly tools are recommended for assembly and installation.
3. O-ring not supplied with connector designator A
4. When max entry is exceeded, style II will be supplied. Dimensions F, G, H and J will not apply
5. Recovered dimension apply to unrestricted recovery. Dimensions may differ than shown when boots are installed over assembly.

Material and Finish

- Elbow, adapter, and coupling nut: aluminum alloy/see how to order table
- Boot: see boot material table
- Braid: see braid table
- O-ring: silicone/N.A.
- Anti-decoupling device: corrosion resistant material

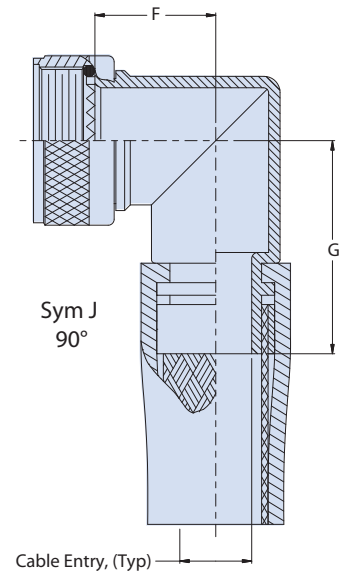
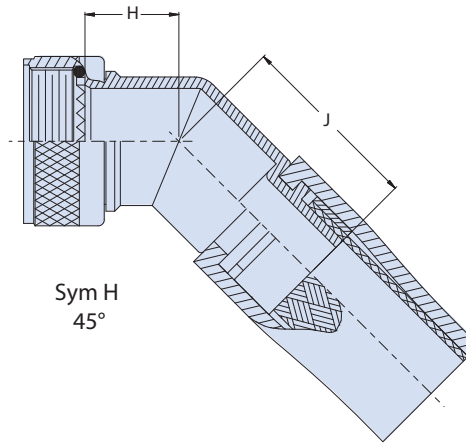

Dimensions					
Shell Size by Designator		F	G	H	J
A, F	H	Max	Max	Max	Max
08	09	1.096 (27.8)	1.155 (29.3)	.986 (25.0)	1.045 (26.5)
10	11	1.166 (29.6)	1.225 (31.1)	1.016 (25.8)	1.075 (27.3)
12	13	1.226 (31.1)	1.285 (32.6)	1.038 (26.4)	1.097 (27.9)
14	15	1.286 (32.7)	1.345 (34.2)	1.056 (26.8)	1.125 (28.6)
16	17	1.346 (34.2)	1.405 (35.7)	1.066 (27.1)	1.145 (29.1)
18	19	1.396 (35.5)	1.455 (37.0)	1.106 (28.1)	1.165 (29.6)
20	21	1.466 (37.2)	1.525 (38.7)	1.136 (28.9)	1.195 (30.4)
22	23	1.516 (38.5)	1.575 (40.0)	1.156 (29.4)	1.215 (30.9)
24	25	1.586 (40.3)	1.645 (41.8)	1.186 (30.1)	1.245 (31.6)

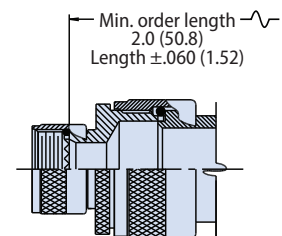

STYLE II - STRAIGHT ONLY

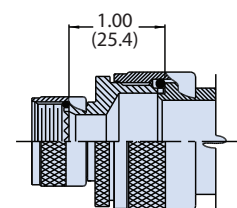

STYLE II - 45° & 90°



SERIES 77

Piggyback Boot Adapters/Backshells



443-040 EMI/RFI Metal Band-in-a-Can Backshell with Self Locking Rotatable Coupling - How to Order

How to Order	
Sample Part Number	443 H S 040 NF 19 06 K S 2 -4
Product Series	443 = Metal piggyback boot backshell with shrink boot nut
Connector Designator	A = MIL-DTL-83723, Series III F = MIL-DTL-38999, Series I & II H = MIL-DTL-38999, Series III & IV
Angular Function	S = Straight J = 90° H = 45°
Basic Number	040
Finish Symbol	M = Electroless nickel MT = Nickel-PTFE NF = Cadmium/O.D. over electroless nickel (500 hours salt spray) ZR = Zinc-nickel, black over electroless nickel
Shell Size	See dimensions table
Entry Code	See cable entry table
Band Option	K = Precoiled Band Omit for none
Slot Option	S = Pigtail Termination Slot Omit for none
Boot Material Type	1 = Type 1 2 = Type 2 3 = Type 3; see boot material table
Length (S Only)	1/2 inch increments: e.g. 4 = 2 inches, see note 2



Boot Material Selection Guide			
Attribute	Type 1	Type 2	Type 3
	High-Performance Semi-Rigid Elastomer	Zero-Halogen Semi-Rigid Polyolefin	General Purpose Flexible Polyolefin
Continuous Operating Temp.	-75° to +150° c	-40° to +130° c	-55° to +135° c
Resistance To Fuels, Oils	Excellent	Very Good	Good
Low Toxicity, Zero Halogen	No	Yes	No

NOTES

- See Table I on Page H-3 for connector designator interface dimensions
 - Standard minimum length is 1.5 inches for style I, and 2.0 inches for style II. Consult factory for additional sizes available.
 - Interface o-ring supplied with connector designator F and H only. O-ring not supplied with connector designator A
 - One band supplied with each assembly. To order separately see 600-052-1 Use with Glenair 601-100 hand or 601-106 pneumatic tools.
 - When max entry is exceeded, style II will be supplied. Dimensions F, G, H, and J will not apply.
 - Recovered dimension apply to unrestricted recovery. Dimensions may differ than shown when boots are installed over assembly.
- Material and Finish**
- Adapters and coupling nut: aluminum alloy/see how to order table
 - Shrink boot: elastomeric/N.A.
 - O-ring: silicone/N.A.
 - Anti-rotational device: corrosion resistant material

H



SERIES 77

Piggyback Boot Adapters/Backshells



443-040 EMI/RFI Metal Band-in-a-Can Backshell with Self Locking Rotatable Coupling - Dimensions

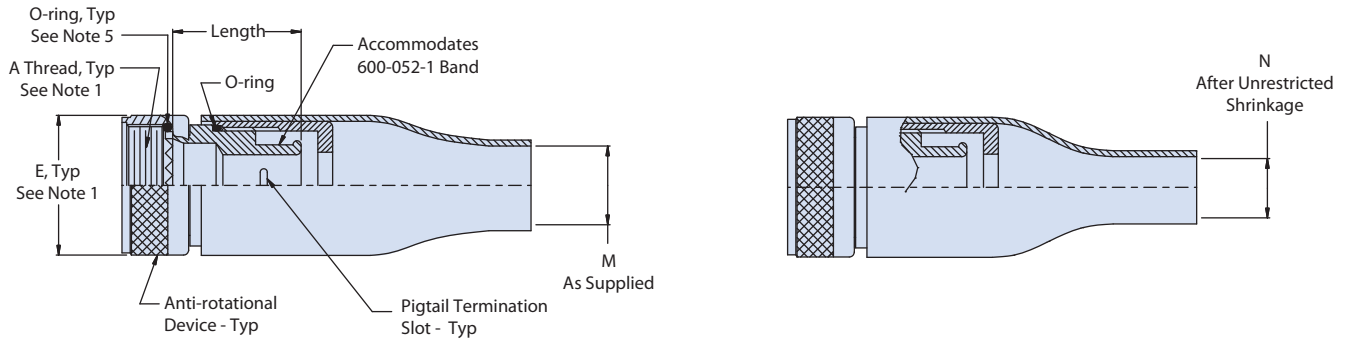

Sym S
Straight

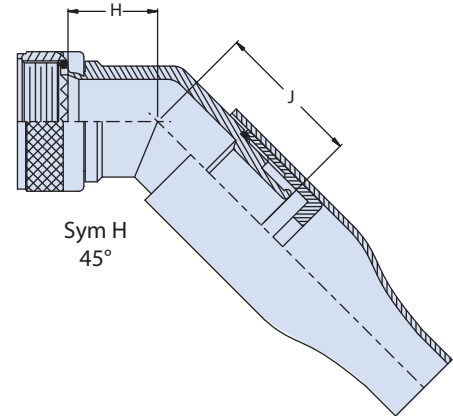
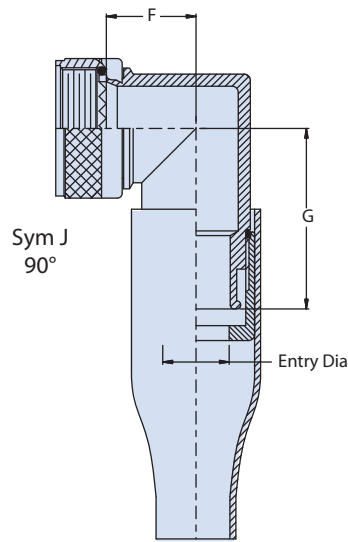
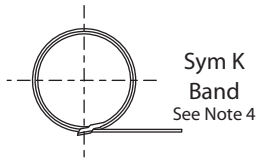

Cable Entry Code			
Entry Code	Entry Dia Min	M Min	N Max
01	.25 (6.35)	.25 (6.35)	.118 (3.00)
02	.37 (9.40)	.37 (9.40)	.197 (5.00)
03	.43 (10.92)	.43 (10.92)	.197 (5.00)
04	.50 (12.70)	.50 (12.70)	.236 (5.99)
05	.62 (15.75)	.62 (15.75)	.236 (5.99)
06	.75 (19.05)	.75 (19.05)	.276 (7.01)
07	.87 (22.10)	.87 (22.10)	.335 (8.51)
08	1.00 (25.40)	1.00 (25.40)	.335 (8.51)
09	1.12 (28.45)	1.12 (28.45)	.335 (8.51)
10	1.25 (31.75)	1.25 (31.75)	.394 (10.01)
11	1.38 (35.05)	1.38 (35.05)	.394 (10.01)
12	1.50 (38.10)	1.50 (38.10)	.394 (10.01)

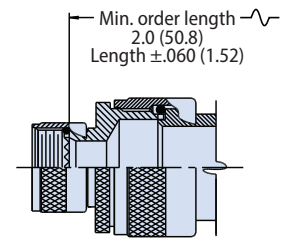

Dimensions								
Shell Size by Designator			F MAX	G MAX	H MAX	J MAX	Max Entry Dash No.	
A, F	H	A					F, H	
08	09	0.90(22.9)	1.50(38.1)	0.789(20.0)	1.38(35.1)	01	01	
10	11	0.96(24.4)	1.55(39.4)	0.814(20.7)	1.41(35.8)	02	02	
12	13	1.02(25.9)	1.61(40.9)	0.838(21.3)	1.43(36.3)	04	04	
14	15	1.07(27.2)	1.68(42.7)	0.855(21.7)	1.46(37.1)	04	05	
16	17	1.13(28.7)	1.74(44.2)	0.882(22.4)	1.48(37.6)	05	06	
18	19	1.17(29.7)	1.76(44.7)	0.898(22.8)	1.49(37.8)	06	07	
20	21	1.23(31.2)	1.82(46.2)	0.923(23.4)	1.51(38.4)	07	08	
22	23	1.29(32.8)	1.90(48.3)	0.950(24.1)	1.55(39.4)	08	09	
24	25	1.35(34.3)	1.97(50.0)	0.973(24.7)	1.58(40.1)	09	09	

STYLE II - STRAIGHT ONLY

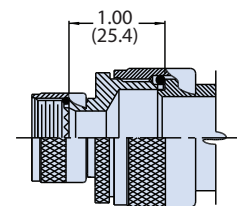

STYLE II - 45° & 90°





SERIES 77

Piggyback Boot Adapters/Backshells



630-101 Metal Feed-thru with Preinstalled Shrink Boot - How to Order

How to Order	
Sample Part Number	630-101 NF 10 A -2 D
Product Series	630-101 = Metal Feed-Thru
Finish Symbol	M = Electroless nickel MT = Nickel-PTFE NF = Cad/O.D. over electroless nickel (500 hour salt spray) ZR = Zinc-nickel, black over electroless nickel
Dash Number	See dimensions table
Style	A = Feed-thru and shrink boot (one side) B = Feed-thru with shrink boots on both sides
Boot Material Type	See boot material selection guide table
Mounting Hole Type	D = 'D' type mounting hole, available for style A only Omit for none



Boot Material Selection Guide			
Attribute	Type 1	Type 2	Type 3
	High-Performance Semi-Rigid Elastomer	Zero-Halogen Semi-Rigid Polyolefin	General Purpose Flexible Polyolefin
Continuous Operating Temp.	-75° to +150° c	-40° to +130° c	-55° to +135° c
Resistance To Fuels, Oils	Excellent	Very Good	Good
Low Toxicity, Zero Halogen	No	Yes	No

NOTES

- Glenair 600 series backshell assembly tools are recommended for assembly and installation.
- Recovered dimension apply to unrestricted recovery. Dimensions may differ than shown when boots are installed over assembly.

Materials and Finish

- Feed-thru bodies, adapter and jam nut: aluminum alloy; see how to order table for finish
- O-ring: Silicone/N.A.
- Shrink Boot: Elastomeric/N.A.

H



SERIES 77

Piggyback Boot Adapters/Backshells



630-101 Metal Feed-thru with Presintalled Shrink Boot - Dimensions

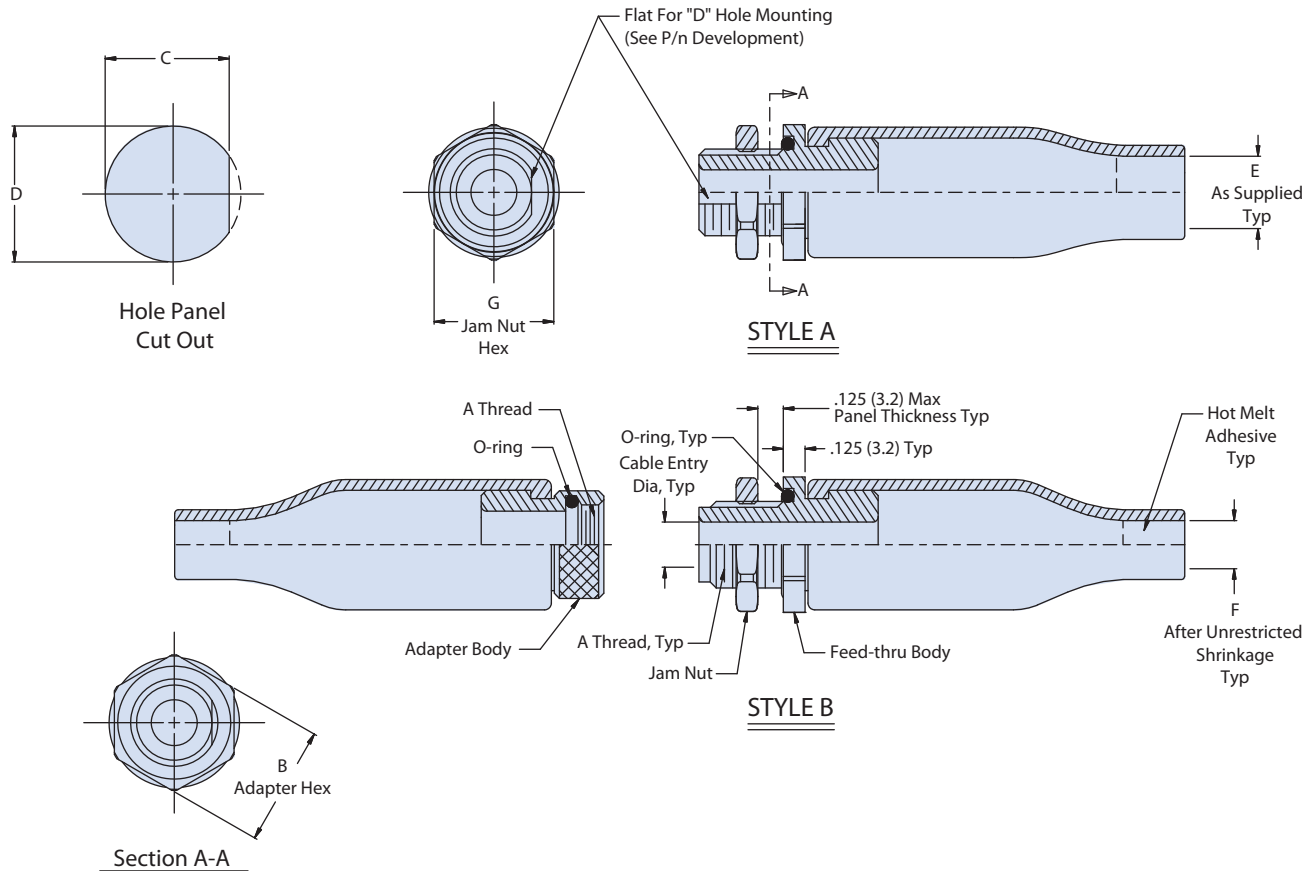

Dimensions								
Dash No	A Thread Class 2B	Cable Entry Ø	B Hex	C Flat +.010 0.000	D Dia +.015 0.000	E Min	F Max	G Hex
07	7/16-28 UNEF	0.250 (6.35)	0.688 (17.48)	0.385 (9.78)	0.443 (11.25)	0.250 (6.35)	0.197 (5.00)	0.625 (15.88)
08	1/2-28 UNEF	0.313 (7.95)	0.750 (19.05)	0.448 (11.38)	0.505 (12.83)	0.313 (7.95)	0.197 (5.00)	0.688 (17.48)
09	9/16-24 UNEF	0.375 (9.52)	0.813 (20.65)	0.510 (12.95)	0.568 (14.43)	0.375 (9.52)	0.236 (5.99)	0.750 (19.05)
10	5/8-24 UNEF	0.438 (11.13)	0.875 (22.23)	0.573 (14.55)	0.630 (16.00)	0.438 (11.13)	0.236 (5.99)	0.812 (20.62)
11	11/16-24 UNEF	0.500 (12.70)	0.938 (23.83)	0.635 (16.13)	0.693 (17.60)	0.500 (12.70)	0.236 (5.99)	0.875 (22.23)
13	13/16-20 UNEF	0.625 (15.88)	1.125 (28.58)	0.760 (19.30)	0.818 (20.78)	0.625 (15.88)	0.276 (7.01)	1.000 (25.40)
15	15/16-20 UNEF	0.750 (19.05)	1.250 (31.75)	0.885 (22.48)	0.943 (23.95)	0.750 (19.05)	0.335 (8.51)	1.125 (28.58)
17	1 1/16-18 UNEF	0.875 (22.23)	1.375 (34.92)	1.010 (25.65)	1.068 (27.13)	0.875 (22.23)	0.335 (8.51)	1.250 (31.75)
19	1 3/16-18 UNEF	1.000 (25.40)	1.500 (38.10)	1.135 (28.83)	1.193 (30.30)	1.000 (25.40)	0.394 (10.01)	1.375 (34.92)
21	1 5/16-18 UNEF	1.125 (28.58)	1.625 (41.28)	1.260 (32.00)	1.318 (33.48)	1.125 (28.58)	0.394 (10.01)	1.625 (41.28)
23	1 7/16-18 UNEF	1.250 (31.75)	1.750 (44.45)	1.385 (35.18)	1.443 (36.65)	1.250 (31.75)	0.591 (15.01)	1.625 (41.28)
25	1 9/16-18 UNEF	1.375 (34.92)	1.875 (47.63)	1.510 (38.35)	1.568 (39.83)	1.375 (34.92)	0.591 (15.01)	1.750 (44.45)
27	1 11/16-18 UNEF	1.500 (38.10)	2.000 (50.80)	1.635 (41.53)	1.693 (43.00)	1.500 (38.10)	0.591 (15.01)	1.875 (47.63)
30	1 7/8-16 UN	1.688 (42.88)	2.187 (55.55)	1.823 (46.30)	1.880 (47.75)	1.688 (42.88)	0.661 (16.79)	2.125 (53.97)
32	2-18 UNS	1.813 (46.05)	2.312 (58.72)	1.948 (49.48)	2.005 (50.93)	1.813 (46.05)	0.661 (16.79)	2.187 (55.55)
34	2 1/8-16 UN	1.938 (49.23)	2.437 (61.90)	2.073 (52.65)	2.130 (54.10)	1.938 (49.23)	0.661 (16.79)	2.375 (60.33)
36	2 1/4-16 UN	2.063 (52.40)	2.562 (65.07)	2.198 (55.83)	2.255 (57.28)	2.063 (52.40)	1.060 (26.92)	2.437 (61.90)





SERIES 77

Piggyback Boot Adapters/Backshells



Composite Piggyback Boot Reference Guide Material Selection and Finish

The following standard materials are used for the majority of Glenair's composite adapter/backshell products. However, components are not limited to those listed but are representative of the elements used in Glenair's composite adapter/backshell products.

Component	Material	Specification
Bodies, clamps, Saddles, coupling nuts, protective covers, etc.	Composite	AIR 4567, AS85049 ASTM D 5205
Hardware: Such as screws, washers, rivets, wire rope, sash chain, band straps, etc.	Corrosion Resisting Steel	QQ-S-763 (300 Series)
Elastomeric seals: Such as o-rings, cable jacket seals, grommets, etc.	Silicone or Fluorosilicone	ZZ-R-765 or MIL-R-25988
Anti-friction and thrust washers	Fluoropolymer	TFE

Connector Designator Reference		
Designator	Specification	Series
A	MIL-DTL-5015	MS3400
	MIL-DTL-26482	2
	AS81703	3
	MIL-DTL-83723	I & III
	40M39569	
	DEF 5326-3	
	EN 2997, 3646	
	ESC 10, 11	
	LN 29504	
	NFC93422	HE302
	PAN 6432-1, -2	
	PATT 602	
	F	MIL-DTL-38999
40M38277		
PAN 6433-1		
PATT 614		
PATT 616		
NFC93422		HE308, 9
G	MIL-DTL-28840	
H	MIL-DTL-38999	III & IV
	EN3645	
L	EN3372	
	JN 1003	
	LN 29729	
	NFC93422	HE306
	PAN 6433-2	
	PATT 615	
	VG 96912	
U	AS29600	

Composite Adapter Plating Codes	
Sym	Finish
XB	No Plating, Black
XZR	Conductive, Zinc Nickel, Black
XM	Conductive, Electroless Nickel
XMT	Conductive, Ni-PTFE 1000 Hour Grey™
XW	Conductive, Cadmium O.D. Over Electroless Nickel

Composite Plating Code Cross-Reference		
Glenair Finish	MIL-DTL-38999	AS85049
XM	M	M
XW	J	J
XMT		XC

Locking Compound

Glenair recommends **ND VIBRA-TITE® Formula 3** Thread Locking Compound for customers who choose to lock or seal fasteners used on composite products.

Available from ND Industries (www.ndindustries.com), this product is non-reactive to composite resins

1000 Hour Grey™ Ni-PTFE Nickel Fluorocarbon Polymer



The MIL-DTL-38999 Rev L detail specification lists Nickel Fluorocarbon Polymer as a qualified cadmium free plating alternative. This RoHS compliant plating formula is now available on composite interconnect products from Glenair and offers the following benefits in harsh-environment applications:

- 2000+ hour salt spray
- Cadmium free
- Outstanding mating lubricity
- Hexavalent Chromium free
- 500+ mating cycles
- Non-Magnetic



SERIES 77

Piggyback Boot Adapters/Backshells



Composite Piggyback Boot Reference Guide

Table II - Connector Designator Interface Dimensions

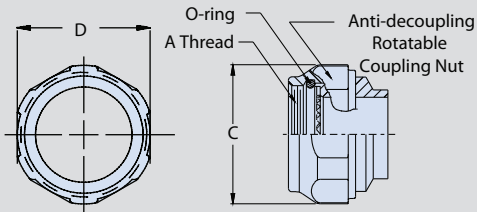

ROTATABLE COUPLING

Notes:

1. Connector shell size designations within are for reference only; do not use in part numbers.
2. Metric dimensions (mm) are in parentheses and are for reference only. (1 inch = 25.4 mm)
3. Consult factory for accessory interface data not listed.
4. Use Glenair 600-091 or 600-157 tool to tighten coupling nut. Rubber jaw pliers or strap wrench may damage the parts.

SHELL SIZE FOR CONNECTOR DESIGNATOR					A THREAD REF	C MAX DIA	D FLATS REF
A	F/L	G	H	U			
-	08 09	-	-	-	7/16 - 28 UNEF	.86 (21.8)	0.75 (19.1)
-	-	-	09 A	-	M12 x 1 - 6H		
08	-	-	-	-	1/2 - 20 UNF		
-	-	-	-	08	1/2 - 28 UNEF	.98 (24.9)	0.88 (22.4)
03	10 11	-	-	-	9/16 - 24 UNEF		
-	-	-	11 B	-	M15 x 1 - 6H		
10	-	-	-	-	5/8 - 24 UNEF	1.16 (29.5)	1.00 (25.4)
-	12 13	-	-	10	5/8 - 24 UN		
-	-	-	13 C	-	M18 x 1 - 6H		
12 7	-	11	-	-	3/4 - 20 UNEF	1.28 (32.50)	1.13 (28.7)
-	14 15	-	-	12	3/4 - 28 UNS		
-	-	-	15 D	-	M22 x 1 - 6H		
14 12	-	13	-	-	7/8 - 20 UNEF	1.41 (35.8)	1.25 (31.8)
-	16 17	-	-	-	15/16 - 20 UNEF		
-	-	-	17 E	-	M25 x 1 - 6H		
16 19	-	15	-	-	1 - 20 UNEF	1.52 (38.6)	1.38 (35.1)
-	-	-	-	16	1 - 28 UN		
18 27	18 19	-	-	-	1 1/16 - 18 UNEF		
-	-	-	19 F	-	M28 x 1 - 6H	1.64 (41.70)	1.50 (38.1)
-	-	17	-	-	1 1/8 - 18 UNEF		
-	-	-	-	18	1 1/8 - 28 UN		
20 37	20 21	-	-	-	1 3/16 - 18 UNEF	1.77 (45.0)	1.63 (41.4)
-	-	-	21 G	-	M31 x 1 - 6H		
-	-	19	-	-	1 1/4 - 18 UNEF		
-	-	-	-	20	1 1/4 - 28 UNEF	1.89 (48.0)	1.75 (44.5)
22	22 23	-	-	-	1 5/16 - 18 UNEF		
-	-	-	23 H	-	M34 x 1 - 6H		
-	-	-	-	22	1 3/8 - 28 UN	2.02 (51.3)	1.88 (47.8)
24	24 25	23	-	-	1 7/16 - 18 UNEF		
-	-	-	25 J	-	M37 x 1 - 6H		
61	-	-	-	-	1 1/2 - 18 UNEF	2.15 (54.6)	2.00 (50.8)
-	-	-	-	24	1 1/2 - 28 UN		
-	-	25	-	-	1 9/16 - 18 UNEF		
28	-	-	-	-	1 3/4 - 18 UNS		





SERIES 77

Piggyback Boot Adapters/Backshells



310-057 Composite Piggyback Boot Adapter with EMI/RFI Drop-in Banding Porch - How to Order

How to Order								
Sample Part Number	310	F	S	057	BM	16	-2	K
Product Series	310 = Environmental piggyback boot							
Connector Designator (See Interface Dimensions Table Below)	A = MIL-DTL-83723, Series III; MIL-DTL-5015; MIL-DTL-26482 F = MIL-DTL-38999, Series I & II H = MIL-DTL-38999, Series III & IV							
Angular Function	S = Straight A = 90° B = 45°							
Basic Number	057							
Finish Symbol	BM = Electroless nickel BMT = Nickel-PTFE, nickel-fluorocarbon polymer BNS = Elective plating, nickel and cad O.D. see detail B							
Shell Size	See Interface Dimensions Table							
Boot Material Type	1 = Type 1 2 = Type 2 3 = Type 3; See boot material selection guide							
Pre-Coiled Band	K = Pre-coiled band Omit for none							



Boot Material Selection Guide			
Attribute	Type 1	Type 2	Type 3
	High-Performance Semi-Rigid Elastomer	Zero-Halogen Semi-Rigid Polyolefin	General Purpose Flexible Polyolefin
Continuous Operating Temp.	-75° to +150° c	-40° to +130° c	-55° to +135° c
Resistance To Fuels, Oils	Excellent	Very Good	Good
Low Toxicity, Zero Halogen	No	Yes	No

NOTES

- See Interface Dimensions table below
 - O-Ring not supplied with Connector Designator A. O-ring supplied with connector designator F and H only
 - Glenair 600-091 or 600-157 series backshell assembly tools are recommended for assembly and installation.
 - Recovered dimension apply to unrestricted recovery. Dimensions may differ than shown when boots are installed over assembly.
- Material and Finish**
- Coupling nut and adapter: high grade engineering thermoplastic black/NA
 - Drop-in adapter: brass/See How to Order table for finish
 - Anti-decoupling device: high grade engineering thermoplastic/NA
 - O-ring: silicone/NA
 - Shrink boot: elastomeric/NA
 - Band: SST/passivated

Interface Dimensions								
Connector Designator A		Connector Designator F		Connector Designator H		C Flats		
Shell Size Ref	A Thread Class 2B	Shell Size Ref	A Thread Class 2B	Shell Size Ref	A Thread Iso Metric	B Dia Ref	Max	Min
08	1/2-20 UNF	08	7/16-28 UNEF	A	M12 x 1.0-6H	.812 (20.6)	.750 (19.1)	.736 (18.7)
10	5/8-24 UNEF	10	9/16-24 UNEF	B	M15 x 1.0-6H	.938 (23.8)	.875 (22.2)	.860 (21.8)
12	3/4-20 UNEF	12	11/16-24 UNEF	C	M18 x 1.0-6H	1.125 (28.6)	1.000 (25.4)	.980 (24.9)
14	7/8-20 UNEF	14	13/16-20 UNEF	D	M22 x 1.0-6H	1.250 (31.8)	1.125 (28.6)	1.100 (27.9)
16	1-20 UNEF	16	15/16-20 UNEF	E	M25 x 1.0-6H	1.375 (34.9)	1.250 (31.8)	1.224 (31.1)
18	1 1/16-18 UNEF	18	1 1/16-18 UNEF	F	M28 x 1.0-6H	1.500 (38.1)	1.375 (34.9)	1.348 (34.2)
20	1 3/16-18 UNEF	20	1 3/16-18 UNEF	G	M31 x 1.0-6H	1.625 (41.3)	1.500 (38.1)	1.469 (37.3)
22	1 5/16-18 UNEF	22	1 5/16-18 UNEF	H	M34 x 1.0-6H	1.750 (44.5)	1.625 (41.3)	1.581 (40.2)
24	1 7/16-18 UNEF	24	1 7/16-18 UNEF	J	M37 x 1.0-6H	1.875 (47.6)	1.750 (44.5)	1.690 (42.9)



SERIES 77

Piggyback Boot Adapters/Backshells



310-057 Composite Piggyback Boot Adapter with EMI/RFI Drop-in Banding Porch - Dimensions

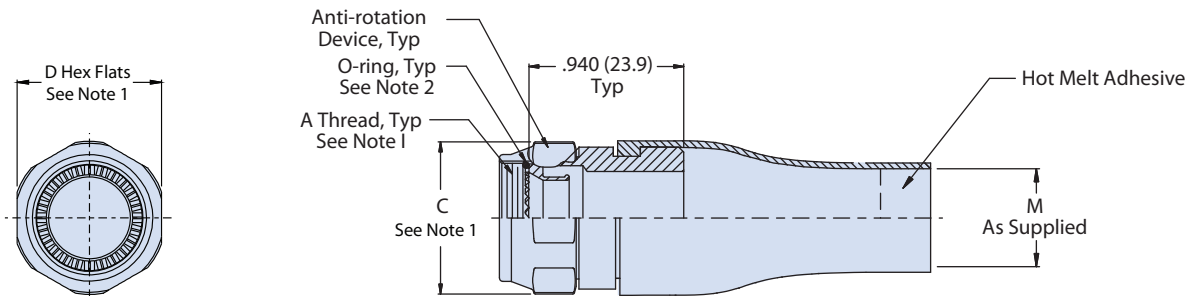

Sym S - Straight

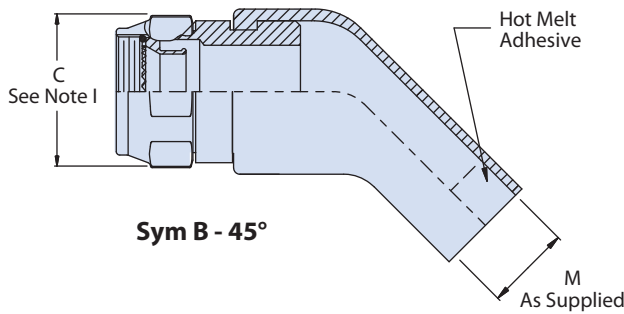

Sym B - 45°

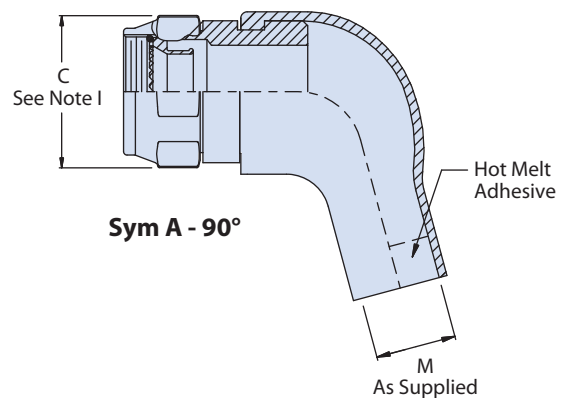

Sym A - 90°

DROP-IN BANDING PORCH

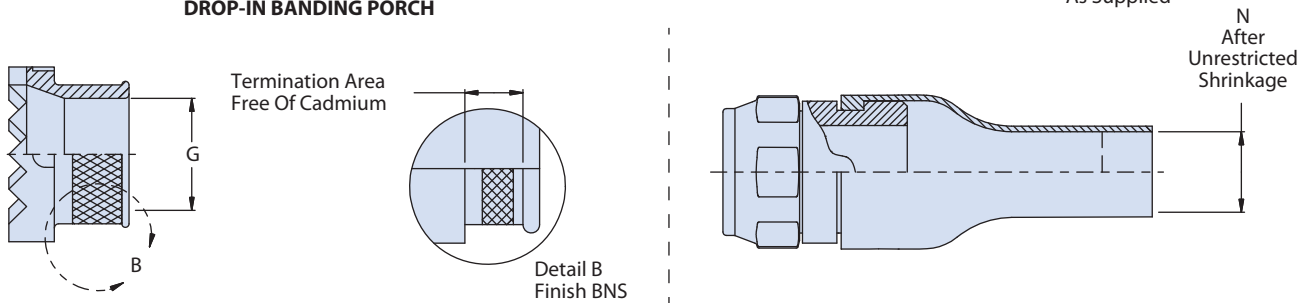

Dimensions				
Shell Size By Connector Desig.		Ø G	M Min	N Max
A, F	H			
08	09	.140 (3.60)	.250 (6.40)	.197 (5.00)
10	11	.270 (6.90)	.355 (9.00)	.197 (5.00)
12	13	.390 (9.90)	.491 (12.5)	.236 (6.00)
14	15	.512 (13.0)	.565 (17.5)	.236 (6.00)
16	17	.637 (16.2)	.690 (19.5)	.276 (7.01)
18	19	.757 (19.2)	.769 (21.4)	.335 (8.51)
20	21	.881 (22.4)	.894 (22.7)	.394 (10.0)
22	23	1.006 (25.6)	1.019 (25.9)	.394 (10.0)
24	25	1.131 (28.7)	1.134 (28.8)	.591 (15.0)

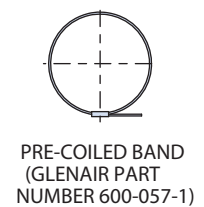



SERIES 77

Piggyback Boot Adapters/Backshells



319-183 EMI/RFI Composite Piggyback Boot Adapter with Integrated Shield Sock - How to Order

How to Order	
Sample Part Number	319 H S 183 XM 19 B 2
Product Series	319 = Environmental piggyback boot
Connector Designator	A = MIL-DTL-83723, Series I & III; MIL-DTL-5015; MIL-DTL-26482 Series II F = MIL-DTL-38999, Series I & II G = MIL-DTL-28840 H = MIL-DTL-38999, Series III & IV U = SAE AS29600 (MIL-C-29600)
Angular Function	S = Straight T = 45° W = 90°
Basic Number	183
Finish Symbol	XM = 2000 hour corrosion resistant electroless nickel XMT = 2000 hour corrosion resistant nickel-PTFE, nickel-fluorocarbon polymer XW = 2000 hour corrosion resistant cadmium olive drab over electroless nickel
Shell Size	See dimensions table
Braid Option	A, B, T, L and dash (-); see braided shielding options table for details
Boot Material Type	1 = Type 1 2 = Type 2 3 = Type 3; see boot material selection guide

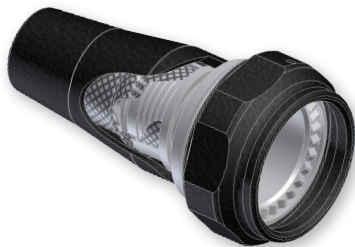

Cutaway View

Boot Material Selection Guide			
Attribute	Type 1	Type 2	Type 3
	High-Performance Semi-Rigid Elastomer	Zero-Halogen Semi-Rigid Polyolefin	General Purpose Flexible Polyolefin
Continuous Operating Temp.	-75° to +150° c	-40° to +130° c	-55° to +135° c
Resistance To Fuels, Oils	Excellent	Very Good	Good
Low Toxicity, Zero Halogen	No	Yes	No

Braided Shielding Options	
Symbol	Braid Type
A	100% AmberStrand®
B	75%/25% AmberStrand® Blend
-	Nickel/Copper 34 AWG
T	Tin/Copper 34 AWG
L	Armorlite™

NOTES

1. See Table II on Page H-15 for connector designator interface dimensions
2. O-ring supplied with connector designator F and H only.
3. Glenair 600-091 or 600-157 Series backshell assembly tools are recommended for assembly and installation.
4. Recovered dimension apply to unrestricted recovery. Dimensions may differ than shown when boots are installed over assembly.

Material and Finish

- Elbow, adapter: high grade engineering thermoplastic. See How to Order Table for finish
- Coupling nut, Anti-decoupling device: high grade engineering thermoplastic (black)/N.A.
- O-ring: silicone/N.A.
- Shrink boot: elastomeric/N.A.
- Anti-decoupling device: high grade engineering thermoplastic/N.A.
- Braid: see braid shielding table
- Band: SST/passivated



SERIES 77

Piggyback Boot Adapters/Backshells



319-183 EMI/RFI Composite Piggyback Boot Adapter with Integrated Shield Sock - Dimensions

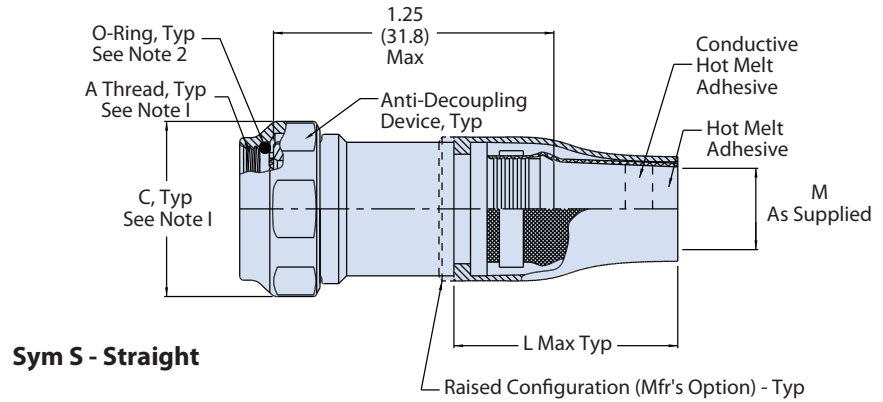
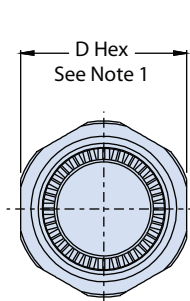

Sym S - Straight

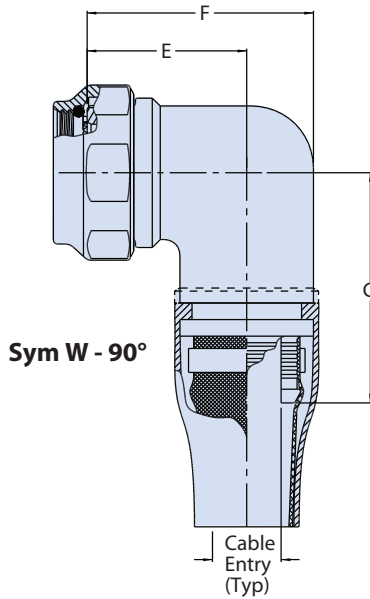

Sym W - 90°

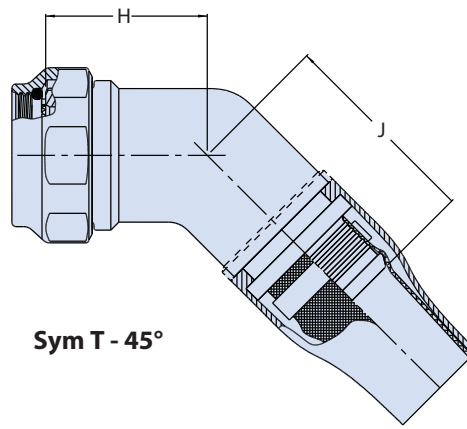

Sym T - 45°

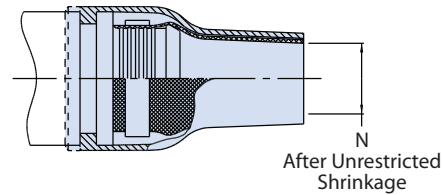

After Unrestricted Shrinkage

Dimensions													
Shell Size by Connector Designator					E	F	G	H	J	Cable Entry	L Max	M	N
A	F/L	G	H	U	±.060 (1.5)	±.090 (2.3)	±.090 (2.3)	±.060 (1.5)	±.090 (2.3)	±.03 (0.8)		Min	Max
08	08	-	09	-	.690 (17.5)	.880 (22.4)	1.19 (30.2)	.720 (18.3)	1.00 (25.4)	.250 (6.40)	1.42 (36.07)	.26 (6.60)	.187 (4.75)
10	10	-	11	08	.750 (19.1)	1.00 (25.4)	1.25 (31.8)	.750 (19.1)	1.06 (26.9)	.380 (9.70)	1.45 (36.83)	.43 (10.92)	.197 (5.00)
12	12	11	13	10	.810 (20.6)	1.13 (28.7)	1.31 (33.3)	.750 (19.1)	1.13 (28.7)	.500 (12.7)	2.10 (53.34)	.56 (14.22)	.236 (5.99)
14	14	13	15	12	.880 (22.4)	1.31 (33.3)	1.38 (35.1)	.760 (19.3)	1.16 (29.5)	.630 (16.0)	2.05 (52.07)	.68 (17.27)	.236 (5.99)
16	16	15	17	14	.940 (23.9)	1.38 (35.1)	1.44 (36.6)	.780 (19.8)	1.18 (30.0)	.750 (19.1)	2.00 (50.80)	.81 (20.57)	.236 (5.99)
18	18	17	19	16	.970 (24.6)	1.44 (36.6)	1.47 (37.3)	.790 (20.1)	1.19 (30.2)	.810 (20.6)	2.60 (66.04)	.87 (22.10)	.276 (7.01)
20	20	19	21	18	1.06 (26.9)	1.63 (41.4)	1.56 (39.6)	.820 (20.8)	1.22 (31.0)	.940 (23.9)	3.10 (78.74)	1.00 (25.4)	.335 (8.51)
22	22	-	23	20	1.13 (28.7)	1.75 (44.5)	1.63 (41.4)	.860 (21.8)	1.26 (32.0)	1.06 (26.9)	3.85 (97.79)	1.12 (28.45)	.394 (10.01)
24	24	23	25	22	1.19 (30.2)	1.88 (47.8)	1.69 (42.9)	.890 (22.6)	1.29 (32.8)	1.19 (30.2)	3.80 (96.52)	1.25 (31.75)	.394 (10.01)
28	-	25	-	24	1.34 (34.0)	2.13 (54.1)	1.78 (45.2)	.920 (23.4)	1.32 (33.5)	1.38 (35.1)	3.75 (95.25)	1.43 (36.32)	.394 (10.01)





SERIES 77

Piggyback Boot Adapters/Backshells



443-033 Composite Band-in-a-Can Piggyback Boot Backshell with Thread-on Shrink Boot - How to Order

How to Order	
Sample Part Number	443 H S 033 XM 19 20 K S -2
Product Series	443 = Environmental piggyback boot
Connector Designator	A = MIL-DTL-83723 Series I & III MIL-DTL-5015; MIL-DTL-26482 Series II F = MIL-DTL-38999, Series I & II G = MIL-DTL-28840 H = MIL-DTL-38999, Series III & IV U = SAE AS29600 (MIL-C-29600)
Angular Function	S = Straight W = 90°
Basic Number	033
Finish Symbol	XM = 2000 hour corrosion resistant electroless nickel XMT = 2000 hour corrosion resistant Ni-PTFE, nickel-fluorocarbon polymer XW = 2000 hour corrosion resistant cadmium olive drab over electroless nickel
Shell Size	See dimensions table
Entry Code	See cable entry table
Band Option	K = Pre-coiled band Omit for none
Slot Option	S = Pigtail slot Omit for none
Boot Material Type	1 = Type 1 2 = Type 2 3 = Type 3; See boot material selection guide



H
Our easiest to use and most versatile, individual and overall, shield termination and pre-terminated shrink boot adapter!

NOTES

1. See Table II on Page H-15 for connector designator interface dimensions
2. Coupling nut supplied unplated
3. O-Ring supplied with Connector Designator F and H only
4. Glenair 600-091 or 600-157 Series Backshell Assembly Tools are recommended for assembly and installation.
5. Consult factory for additional sizes available
6. Entry diameter equals max wire bundle diameter
7. One band supplied with each assembly. To order separately, see 601-041
8. Use Glenair 601-100 or 601-102 hand or 601-106 pneumatic banding tools
9. Recovered dimension apply to unrestricted recovery. Dimensions may differ than shown when boots are installed over assembly.

Material and Finish

- Adapter, elbow: high grade engineering thermoplastic/see How to Order table for finish
- Hardware: cres/passivated
- O-ring: silicone/na
- Anti-decoupling device: high grade engineering thermoplastic/N.A.
- Coupling nut, body clamp, support ring: high grade engineering thermoplastic/black unplated
- Band: SST/passivated
- Shrink boot: see boot material table



SERIES 77

Piggyback Boot Adapters/Backshells



443-033 Composite Band-in-a-Can Piggyback Boot Backshell with Thread-on Shrink Boot - Dimensions

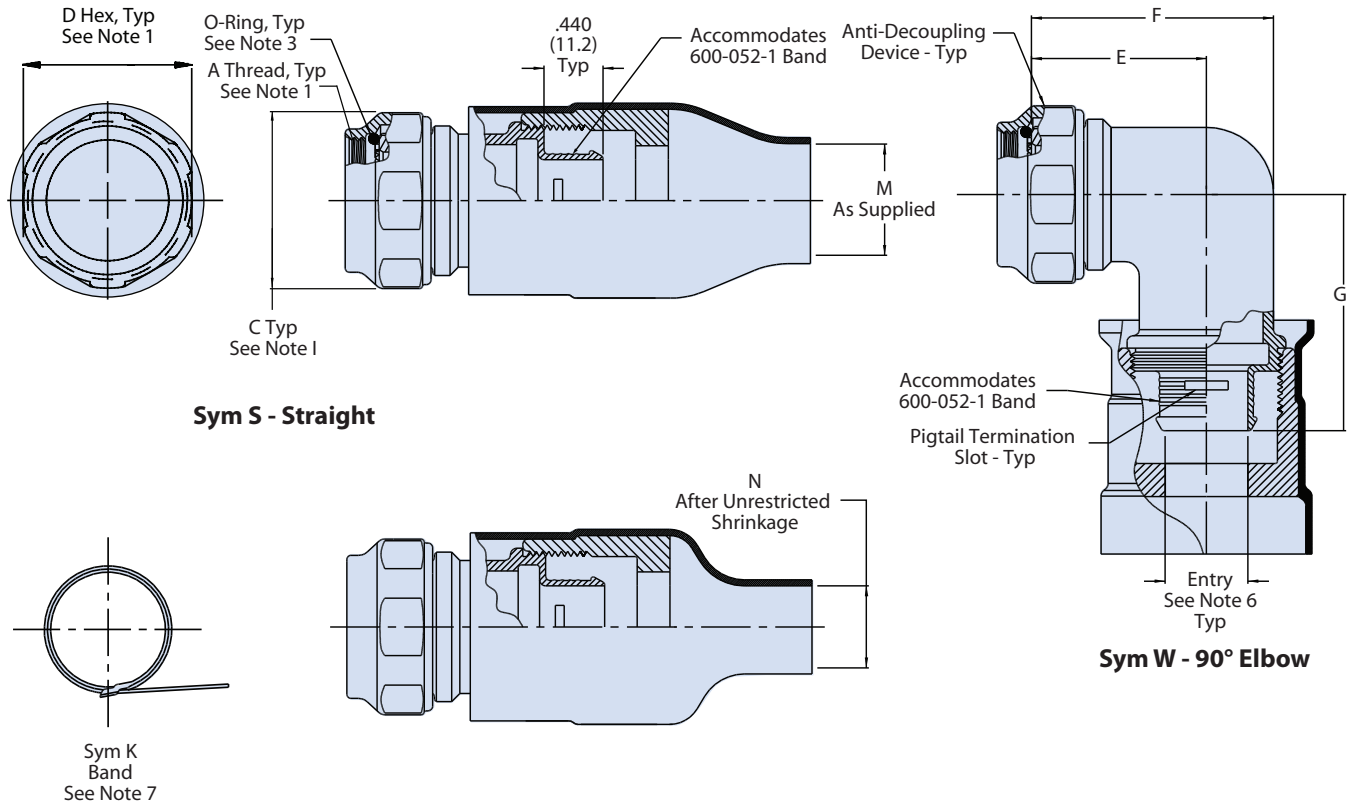

Dimensions										
Shell Size					E ±.06 (1.5)	F ±.090 (2.3)	G ±.090 (2.3)	Max Entry Dash No.		
A	F/L	G	H	U						
08	08	-	09	-	.69 (17.5)	.880 (22.4)	1.19 (30.2)	10		
10	10	-	11	08	.75 (19.1)	1.00 (25.4)	1.25 (31.8)	12		
12	12	11	13	10	.81 (20.6)	1.13 (28.7)	1.31 (33.3)	14		
14	14	13	15	12	.88 (22.4)	1.31 (33.3)	1.38 (35.1)	16		
16	16	15	17	14	.94 (23.9)	1.38 (35.1)	1.44 (36.6)	18		
18	18	17	19	16	.97 (24.6)	1.44 (36.6)	1.47 (37.3)	20		
20	20	19	21	18	1.06 (26.9)	1.63 (41.4)	1.56 (39.6)	22		
22	22	-	23	20	1.13 (28.7)	1.75 (44.5)	1.63 (41.4)	24		
24	24	23	25	22	1.19 (30.2)	1.88 (47.8)	1.69 (42.9)	28		
28	-	25	-	24	1.34 (34.0)	2.13 (54.1)	1.78 (45.2)	32		

Cable Entry			
Entry Code	Entry Dia. (See Note 6) ±.03 (0.8)	M Min	N Max
10	.22 (5.6)	.33 (8.40)	.236 (6.0)
12	.28 (7.1)	.43 (11.0)	.236 (6.0)
14	.34 (8.6)	.51 (13.0)	.276 (7.0)
16	.46 (11.7)	.67 (17.0)	.276 (7.0)
18	.55 (14.0)	.75 (19.0)	.276 (7.0)
20	.62 (15.7)	.82 (20.8)	.335 (8.5)
22	.70 (17.8)	.96 (24.4)	.335 (8.5)
24	.78 (19.8)	1.05 (26.7)	.335 (8.5)
28	.85 (21.6)	1.18 (30.0)	.335 (8.5)
32	.95 (24.1)	1.31 (33.3)	.394 (10.0)

Boot Material Selection Guide			
Attribute	Type 1	Type 2	Type 3
	High-Performance Semi-Rigid Elastomer	Zero-Halogen Semi-Rigid Polyolefin	General Purpose Flexible Polyolefin
Continuous Operating Temp.	-75° to +150° c	-40° to +130° c	-55° to +135° c
Resistance To Fuels, Oils	Excellent	Very Good	Good
Low Toxicity, Zero Halogen	No	Yes	No





SERIES 77

Piggyback Boot Adapters/Backshells



630-103 Composite Feed-thru with Shrink Boot How to Order

How to Order						
Sample Part Number	630-103	XM	07	A	-2	D
Product Series	630-103 = Composite Feed-Thru					
Finish Symbol	XM = Electroless nickel XW = Cad/O.D. over electroless nickel XZR = Zinc-nickel, black over electroless nickel XMT = Nickel-PTFE					
Dash Number	See dimensions table					
Style	A = Feed-thru and shrink boot (one side) B = Feed-thru with shrink boots on both sides					
Boot Material Type	See boot material selection guide table					
Mounting Hole Type	D = 'D' type mounting hole, available for style A only; omit for none					



Boot Material Selection Guide			
Attribute	Type 1	Type 2	Type 3
	High-Performance Semi-Rigid Elastomer	Zero-Halogen Semi-Rigid Polyolefin	General Purpose Flexible Polyolefin
Continuous Operating Temp.	-75° to +150° c	-40° to +130° c	-55° to +135° c
Resistance To Fuels, Oils	Excellent	Very Good	Good
Low Toxicity, Zero Halogen	No	Yes	No

NOTES

- Glenair 600 series backshell assembly tools are recommended for assembly and installation.
- Recovered dimension apply to unrestricted recovery. Dimensions may differ than shown when boots are installed over assembly.

Materials and Finish

- Feed-thru bodies, adapter and jam nut: high grade engineering thermoplastic. See How to Order table
- O-ring: Silicone/N.A.
- Shrink Boot: Elastomeric/N.A.

H



SERIES 77

Piggyback Boot Adapters/Backshells



630-103 Composite Feed-thru with Shrink Boot Dimensions

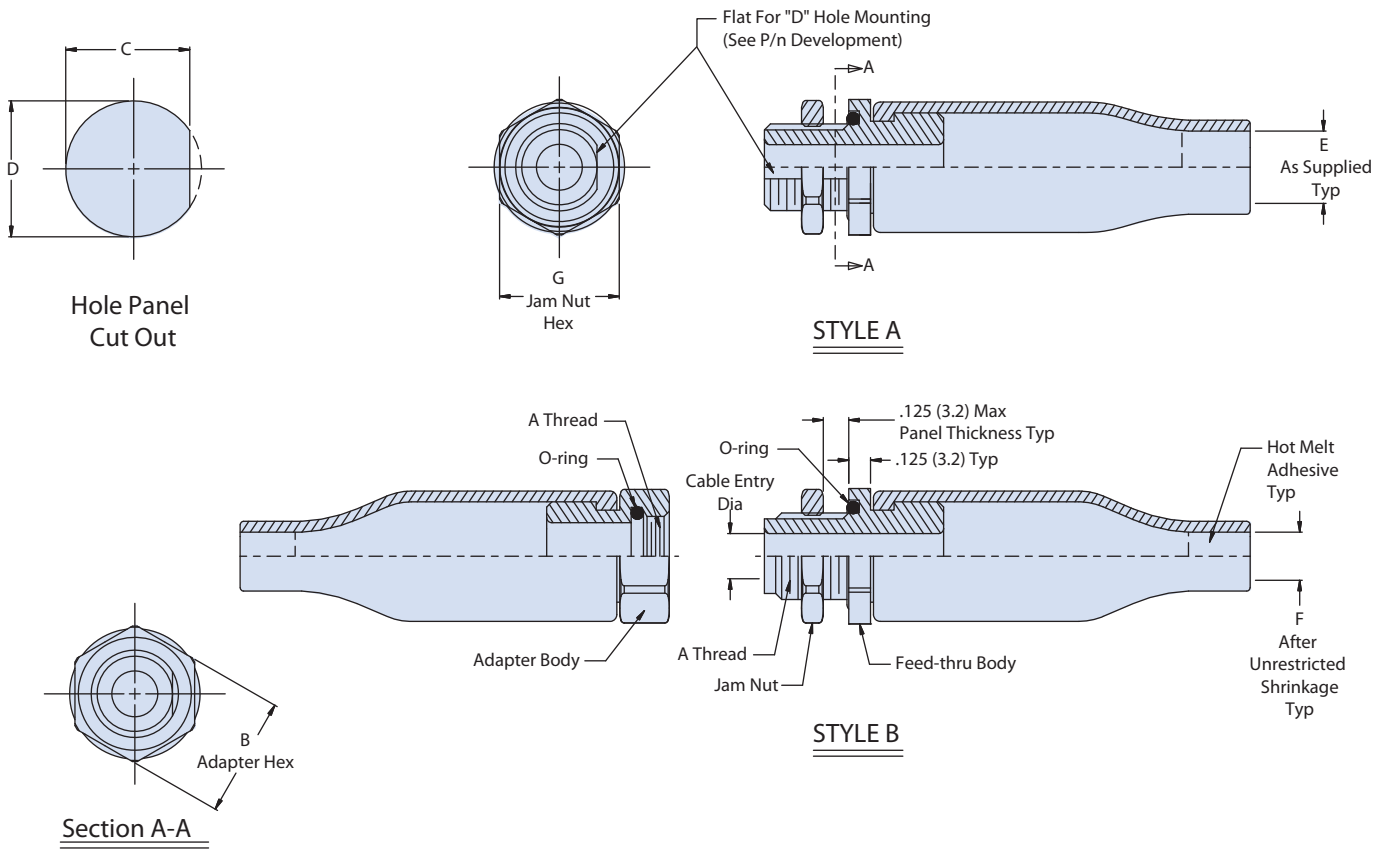

Dimensions								
Dash No	A Thread Class 2B	Cable Entry Ø Min	B Hex	C Flat +.010 0.000	D Dia +.015 0.000	E Min	F Max	G Hex
07	7/16-28 UNEF	0.215 (5.46)	0.688 (17.48)	0.385 (9.78)	0.443 (11.25)	0.215 (5.46)	0.197 (5.00)	0.625 (15.88)
08	1/2-28 UNEF	0.278 (7.06)	0.750 (19.05)	0.448 (11.38)	0.505 (12.83)	0.278 (7.06)	0.197 (5.00)	0.688 (17.48)
09	9/16-24 UNEF	0.340 (8.64)	0.813 (20.65)	0.510 (12.95)	0.568 (14.43)	0.340 (8.64)	0.236 (5.99)	0.750 (19.05)
10	5/8-24 UNEF	0.403 (10.24)	0.875 (22.23)	0.573 (14.55)	0.630 (16.00)	0.403 (10.24)	0.236 (5.99)	0.812 (20.62)
11	11/16-24 UNEF	0.465 (11.81)	0.938 (23.83)	0.635 (16.13)	0.693 (17.60)	0.465 (11.81)	0.236 (5.99)	0.875 (22.23)
13	13/16-20 UNEF	0.590 (14.99)	1.125 (28.58)	0.760 (19.30)	0.818 (20.78)	0.590 (14.99)	0.276 (7.01)	1.000 (25.40)
15	15/16-20 UNEF	0.715 (18.16)	1.250 (31.75)	0.885 (22.48)	0.943 (23.95)	0.715 (18.16)	0.335 (8.51)	1.125 (28.58)
17	1 1/16-18 UNEF	0.840 (21.34)	1.375 (34.92)	1.010 (25.65)	1.068 (27.13)	0.840 (21.34)	0.335 (8.51)	1.250 (31.75)
19	1 3/16-18 UNEF	0.965 (24.51)	1.500 (38.10)	1.135 (28.83)	1.193 (30.30)	0.965 (24.51)	0.394 (10.01)	1.375 (34.92)
21	1 5/16-18 UNEF	1.090 (27.69)	1.625 (41.28)	1.260 (32.00)	1.318 (33.48)	1.090 (27.69)	0.394 (10.01)	1.625 (41.28)
23	1 7/16-18 UNEF	1.215 (30.86)	1.750 (44.45)	1.385 (35.18)	1.443 (36.65)	1.215 (30.86)	0.591 (15.01)	1.625 (41.28)
25	1 9/16-18 UNEF	1.340 (34.04)	1.875 (47.63)	1.510 (38.35)	1.568 (39.83)	1.340 (34.04)	0.591 (15.01)	1.750 (44.45)
27	1 11/16-18 UNEF	1.465 (37.21)	2.000 (50.80)	1.635 (41.53)	1.693 (43.00)	1.465 (37.21)	0.591 (15.01)	1.875 (47.63)
30	1 7/8-16 UN	1.653 (41.99)	2.187 (55.55)	1.823 (46.30)	1.880 (47.75)	1.653 (41.99)	0.661 (16.79)	2.125 (53.97)
32	2-18 UNS	1.778 (45.16)	2.312 (58.72)	1.948 (49.48)	2.005 (50.93)	1.778 (45.16)	0.661 (16.79)	2.187 (55.55)
34	2 1/8-16 UN	1.903 (48.34)	2.437 (61.90)	2.073 (52.65)	2.130 (54.10)	1.903 (48.34)	0.661 (16.79)	2.375 (60.33)
36	2 1/4-16 UN	2.028 (51.51)	2.562 (65.07)	2.198 (55.83)	2.255 (57.28)	2.028 (51.51)	1.060 (26.92)	2.437 (61.90)





SERIES 77
Shrink Boots



Heat Shrink Boot Installation Selection Guide

General Heat Shrink Boot General Installation Guide	Page J-2
Heat Shrink Boot with W1 or W3 Adhesive Installation Guide	Page J-6
Heat Shrink Boot with W2 Adhesive Installation Guide	Page J-7
Type R Epoxy Pre-Coat Installation Guide	Page J-8
Type U Two Part Epoxy Installation Guide	Page J-9
Type U Two Part Epoxy How to Order	Page J-10
Composite Backshell or Connector Heat Shrink Boot Installation Guide	Page J-11

Installation procedures are available for the listed material adhesive combinations on the following pages.

Material and Adhesive Matrix					
Material	Hot Melt Adhesive			Epoxy	
	W1	W2	W3	R	U Two Part Epoxy
Type 1 (2025)	✓	✓		✓	✓
Type 2 (2010)	✓	✓		✓	✓
Type 3 (2040)		✓			✓
Type 4 (2012)					✓
Type 5 (2050)	✓		✓	✓	✓
Type 6 (2051)	✓		✓		✓
Type 7 (2071)	✓	✓			✓
Type 8 (2008)					✓
Type 9 (2013)		✓			✓





SERIES 77 Shrink Boots



Heat Shrink Boot General Installation Guide

METHODS FOR SHRINKING PARTS

These application guides are to support operators who have been trained in the installation of heat shrinkable products, the use of adhesives and product evaluation. Operators will have been made aware of all health and safety issues and is aware of the relevant SDS for heat shrink materials, specified adhesives and cleaning materials. Safety Data Sheets (SDS) are available at www.glenair.com/html/compliance.htm

WARNING:

The use of heat shrinkable products entails the potential exposure of people to heat, solvents and gases. Every precaution is to be taken against harmful effects by the use of protective gloves, safety glasses and good ventilation. All local health and safety regulations should be adhered to and operators should follow designated safe working practices. The use of protective gloves and barrier creams are recommended when using solvents and adhesives. Repeated skin contact should be avoided and care should be taken to wear safety glasses when handling these materials. Attention should be taken to follow the recommendations of the relevant SDS sheets of the materials being used.

APPLICATION EQUIPMENT

Heat Source

A suitable Leister or Steinel hot air gun is recommended. Other heat guns may be used but these must be able to deliver hot air at the temperatures recommended in these installation guides. Reflectors can assist in the process of recovering parts. Always ensure the air vent on the rear of the hot air gun is open and free of dust and or other materials. Always allow the hot air gun to reach the required temperature and to stabilize before starting to shrink parts. It is recommended that the Heat Gun is calibrated daily by the use of a thermocouple positioned 25mm from the end of the nozzle.

WARNING:

The surfaces of the nozzles and reflectors reach high temperatures and will cause burns if touched. Great care should be taken when handling these tools especially after use since they take a considerable time to cool.

Cleaning Materials

100 grit Emery Cloth is recommended for abrading surfaces to be adhered to. Isopropyl alcohol (IPA) is recommended for degreasing either as a liquid or an impregnated tissue. (Note safety issues on the use of solvents already documented in this guide.)

PROCEDURE

The following general instructions are applicable to all Glenair heat shrink boots. Specific instructions for surface preparation, the use of adhesive and specific conditions for each molding material are given in the relevant sections following these general instructions.

APPLICATION NOTE:

When preheating of a connector or adapter is required because of size then care should be taken not to damage any insulation or plastic material on either the connector or the wire insulation. Heat should only be applied to metal areas. DO NOT PREHEAT COMPOSITE PARTS.



SERIES 77 Shrink Boots



Heat Shrink Boot General Installation Guide

Step 1: Place Boot on Cable

Position the boot so that the lipped "A" end is toward the adapter and the "C" end is toward the cable .

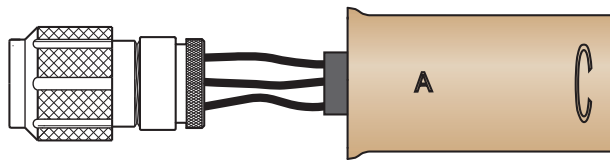

Straight

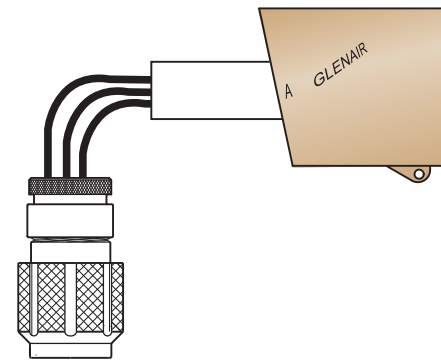

Right Angle

Step 2: Apply Heat to Adapter End of Boot

Position the boot so that the lipped "A" end will recover into the groove of the adapter. Apply heat evenly around the boot at the adapter end. Ensure the boot is fully recovered and the lip fits into the groove of the adapter. This will take approximately 30 seconds for a size 04 or 05 boot, less for smaller parts and longer for larger boots.

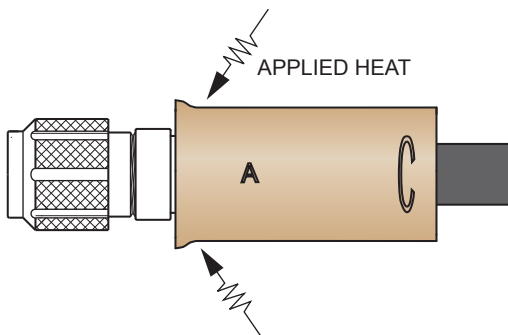

Straight

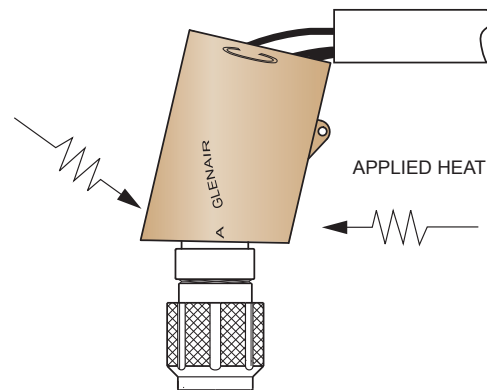

Right Angle



SERIES 77 Shrink Boots



Heat Shrink Boot General Installation Guide

STEP 3: Continue Applying Heat Toward the "C" End of Boot

Continue to heat down the body of the boot towards the "C" end. Apply heat in brush-like strokes, ensuring the last part to recover is the "C" end. A feature of the Glennair boots is that, unlike other boots, they resist the tendency to fold over at the "C" end.

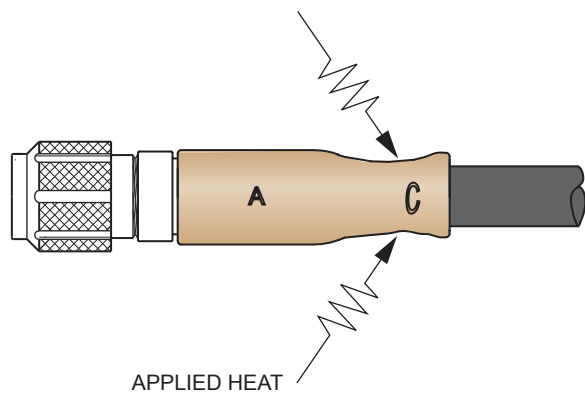
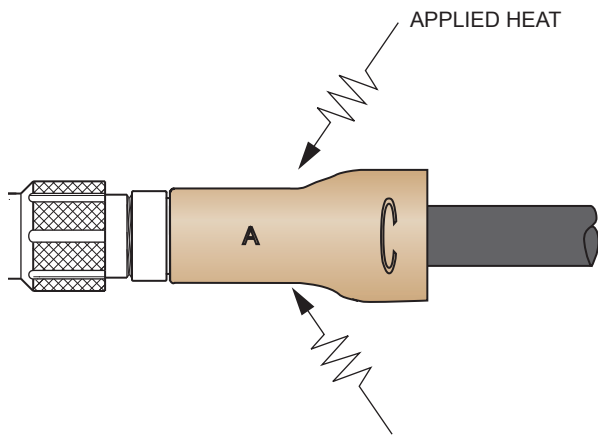

Straight

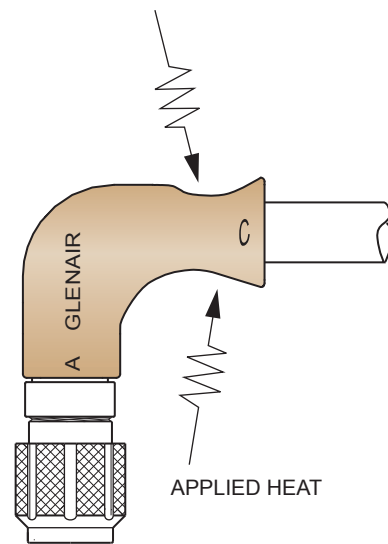
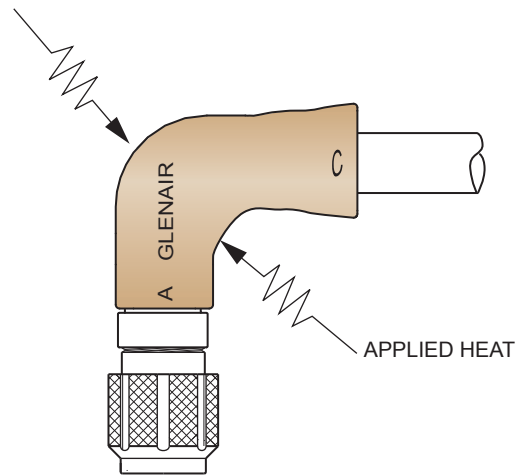

Right Angle

J



SERIES 77 Shrink Boots



Heat Shrink Boot General Installation Guide

STEP 4: After boot is fully recovered, apply further heat to "A" end

After the boot is fully recovered, apply additional heat to the "A" end to ensure adhesive melting and good adhesion. Typically this post heating will require 90-150 seconds depending on size. Refer to the specific instructions for each boot and adhesive type following this section. Care should be taken to avoid damaging the boot with excessive heat. Allow the parts to fully cool before handling.

CAUTION

The recovered parts will remain hot for some time and will be capable of burning skin if touched. Molten adhesive may also cause burns and adhere to exposed skin.

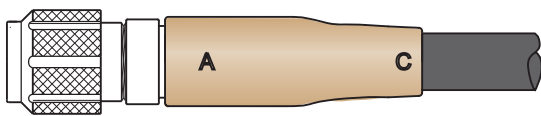

Straight

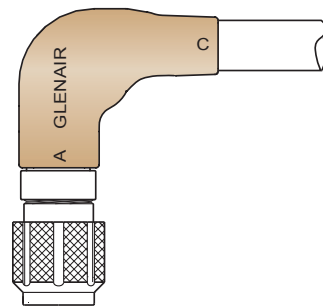

Right Angle

STEP 5: Inspection of Installed Heat shrink Boot

1. The boot should be free of blisters, scorch marks and essentially free from distortion.
2. Any excessive adhesive should be removed.
3. The boot lip should be seated into the adapter groove, and the boot should be properly oriented (straight or right angle).
4. A small fillet of adhesive should be visible between the boot and the cable jacket.



SERIES 77 Shrink Boots



Heat Shrink Boot with 'W1' or 'W3' Pre-Coat Adhesive Installation Guide

INSTALLATION OF HEAT SHRINK BOOTS WITH 'W1' AND 'W3' HOT MELT ADHESIVE

The following instructions apply to Type 1, 2, 5, 6 and 7 heat shrink boots, used in conjunction with 'W1' and 'W3' high temperature hot melt adhesive. Boots are pre-coated at the factory.

Surface Preparation

1. No preparation of the heat shrink boot is required.
2. Degrease the adapter using isopropyl alcohol or IPA impregnated wipes.
2. Abrade the cable jacket thoroughly with 100 grit emery cloth in the region where the part will recover. Remove loose particles with a dry tissue.

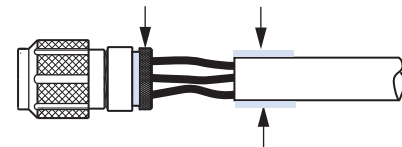

CLEAN ADAPTER
AND ABRABE CABLE

Installation

1. Set heat gun temperature to 230-250°C (446°-482°F), measured at 25mm (1") from the nozzle exit.
2. Allow the heat gun 2 minutes to stabilize.
3. Recover boot in accordance with the general installation procedures, except as follows:
 - After the boot has been recovered remove any excess adhesive with a tissue.
 - Apply a post heat to both the "A" and "C" end to ensure full flow and adhesion of the adhesive. A flow of adhesive around the "C" cable end should be evident.

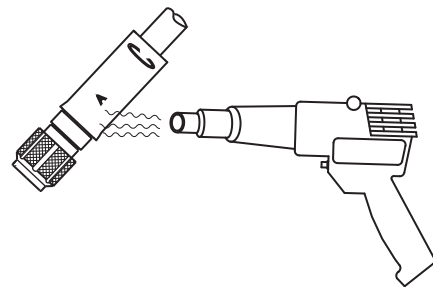

Post Installation and Inspection

1. Allow the part two hours before the inspection stage; however, once the part has cooled the harness can be handled with care.
2. Joints should be inspected per the General Installation Guide.



SERIES 77 Shrink Boots



Heat Shrink Boot with 'W2' Pre-Coat Adhesive Installation Guide

INSTALLATION OF HEAT SHRINK BOOTS WITH 'W2' HOT MELT ADHESIVE

The following instructions apply to Type 1, 2, 3, 7 and 9 heat shrink boots used in conjunction with 'W2' hot melt adhesive. These boots are pre-coated at the factory.

Surface Preparation

1. No preparation of the heat shrink boot is required.
2. Degrease the adapter using isopropyl alcohol or IPA impregnated wipes.
2. Abrade the cable jacket thoroughly with 100 grit emery cloth in the region where the part will recover. Remove loose particles with a dry tissue.

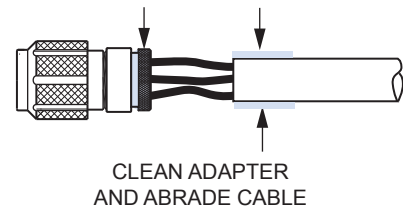

Installation

1. Set heat gun temperature to 200-220° C (392°-428°F), measured at 25mm (1") from the nozzle exit.
2. Allow the heat gun 2 minutes to stabilize.
3. Recover boot in accordance with the general installation procedures, except as follows:
 - After the boot has been recovered remove any excess adhesive with a tissue.
 - Apply a post heat period of 30 seconds to both the "A" and "C" end to ensure full flow and adhesion of the adhesive. A flow of adhesive around the "C" cable end should be evident.

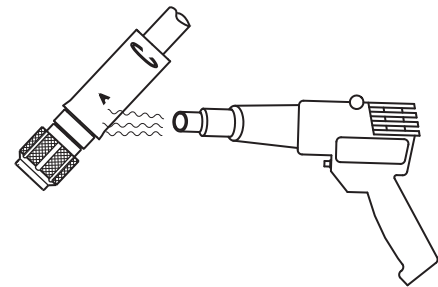

Post Installation and Inspection

1. Allow the part two hours before the inspection stage; however, once the part has cooled the harness can be handled with care.
2. Joints should be inspected per the General Installation Guide.



SERIES 77 Shrink Boots



Heat Shrink Boot with 'R' Pre-Coat Adhesive Epoxy Installation Guide

INSTALLATION OF HEAT SHRINK BOOTS WITH 'R' PRE-COATED, HOT MELT EPOXY ADHESIVE

The following instructions apply to Type 1, 2 and 5 material heat shrink boots with 'R' epoxy. These boots are pre-coated at the factory.

Surface Preparation

1. No preparation of the heat shrink boot is required.
2. Degrease the adapter using isopropyl alcohol or IPA impregnated wipes.
2. Abrade the cable jacket thoroughly with 100 grit emery cloth in the region where the part will recover. Remove loose particles with a dry tissue.

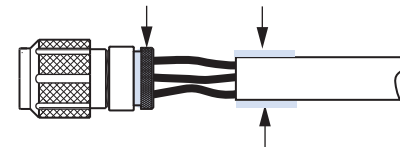

CLEAN ADAPTER AND ABRADE CABLE

Installation

1. Set heat gun temperature to 230-250°C (446°-482°F), measured at 25mm (1") from the nozzle exit.
2. Allow the heat gun 2 minutes to stabilize.
3. Recover boot in accordance with the general installation procedures, except as follows:
 - Do not apply hot air directly onto the adhesive lining of the boot as this may cause premature curing of the epoxy.
 - After the boot has been recovered remove any excess adhesive with a tissue.
 - Apply a post heat period of 2 minutes to both the "A" and "C" end to ensure full cure of the adhesive.

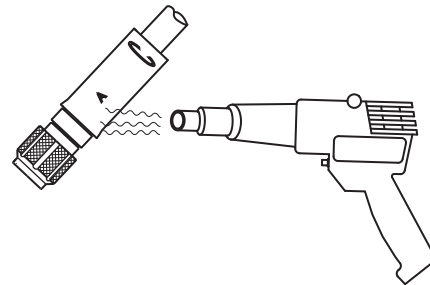

Post Installation and Inspection

1. Allow the part two hours before the inspection stage; however, once the part has cooled the harness can be handled with care.
2. Joints should be inspected per the General Installation Guide.
3. When inspecting boots with Type R epoxy pre-coat, it is acceptable to see a slight opening on the extreme edge of the cable to a maximum of 1mm (.040").

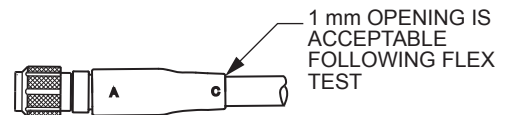



SERIES 77 Shrink Boots



Heat Shrink Boot with 'U' Two Part Epoxy Adhesive Installation Guide

INSTALLATION OF HEAT SHRINK BOOTS WITH USER-INSTALLED TWO PART EPOXY ADHESIVE

Glenair two part epoxy is compatible with all Glenair material Type 1 thru 9. Part number 779-001 duo syringe, 779-002 dispensing gun and 779-003 mixing nozzle are recommended. Epoxy complies with BS G 198 Type U, EC 62329 and VG 95343 Part 15, SAE AS5258 Code 4, and approved to TACOM 12347278 Rev B. Only adhesives that meet the requirements of these specifications are recommended.

Surface Preparation

1. Prepare the inside of the boot in the areas where it will adhere to the adapter and cable jacket by degreasing with isopropyl alcohol or IPA impregnated wipes.
2. Abrade the cable jacket thoroughly with 100 grit emery cloth in the region where the part will recover. Remove loose particles with a dry tissue.

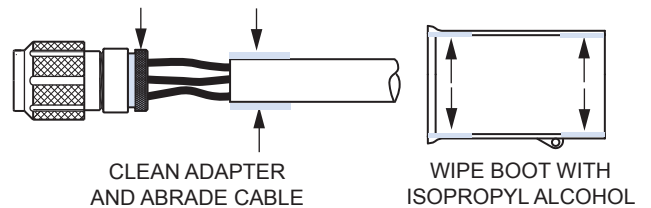

Adhesive Application

1. Prepare adhesive in accordance with the instructions supplied with the adhesive.
2. Apply adhesive to both the "A" and "C" ends of the boot. It is recommended to dispense the adhesive directly onto the surface of the boot. Smooth out the adhesive using a suitable wooden mixing stick.

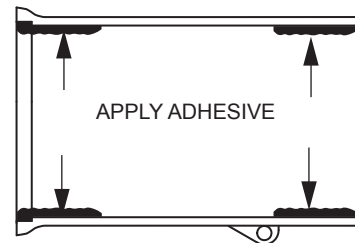

Installation

1. Set heat gun temperature to 230-250°C (446°-482°F), measured at 25mm (1") from the nozzle exit.
2. Allow the heat gun 2 minutes to stabilize.
3. Recover boot in accordance with the general installation procedures.

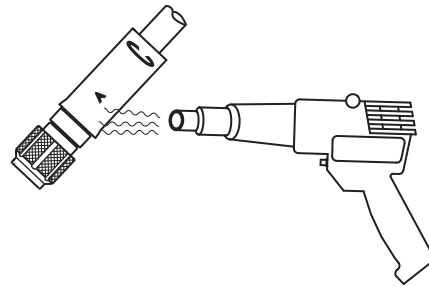

Post Installation

1. Remove any excess adhesive using a dry tissue.
2. Apply a few seconds of additional heat to the "C" end to force a small amount of adhesive to flow and form a fillet between the boot and cable jacket. If necessary smooth fillet with a wooden mixing stick.

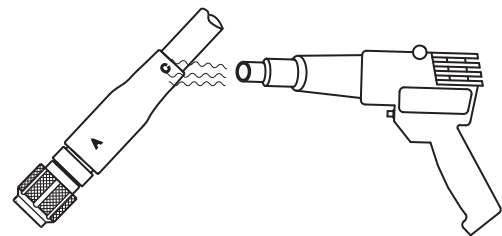

Curing Schedule

12 hours at room temperature, 2 hours at 70°C (158°F), 1 hour at 85°C (185°F), 30 minutes at 150°C (302°F).



SERIES 77 Shrink Boots



Adhesive 'U' Two Part Epoxy How to Order

About User-Installed Epoxy

Epoxy adhesive provides superior bond strength, higher temperature range and better chemical resistance compared to hot melt adhesive. Glenair supplies both type R one-part epoxy pre-coating as well as user-installed two part epoxy—which offers several advantages including reduced boot installation time and an easier installation process. Pre-coated boots require additional care to install because the boot must be heated sufficiently to activate the epoxy, at the risk of overheating the overall assembly. User-installed epoxy has a four hour pot life, and only a small amount is necessary, so a single 50 ml duo syringe can coat many boots. The duo syringe can be re-capped for re-use. Inexpensive mixing nozzles must be discarded after each use. **NOTE: Glenair high-performance two part epoxy meets VG95343 part 15. SAE AS5258 adhesive code U, and TACOM 12347278 Rev B.**

Two Part Epoxy



High performance flexible two part thermoset epoxy provides high strength flexible bond from -75°C to 150°C. 50 ml duo syringe fits standard dispensing guns. Use with square green mixing nozzle sold separately. 12 hour cure time at 20°C, 1 hour at 85°C, 30 minutes at 150°C. Apply to inside of boot with wooden spatula. 18 month shelf life.

Part Number
779-001

Epoxy Dispensing Gun



Twin push-rod 1:1 ratio epoxy dispensing gun for use with duo syringe epoxy and mixing nozzle sold separately. Durable heavy-duty plastic. Gun type hand grip with ratcheting trigger to advance push-rods.

Part Number
779-002

Epoxy Mixing Nozzle



1:1 ratio mixing nozzle attaches to duo syringe with 1/2 turn and locks into place. Nozzle provides consistent mixing of resin and hardener. Kit consists of (12) nozzles. Tip OD: 0.165 (4.19)

Part Number	Count Per Pack
779-003	12

J



SERIES 77 Shrink Boots



Composite Backshell or Connector Heat Shrink Boot Recommended Installation Guide

INSTALLING HEAT SHRINK BOOTS ON COMPOSITE CONNECTORS

Attention is required to set the heat gun to the proper heat level when incorporating a shrink boot on a composite backshell or connector. To avoid possible damage to composite parts when installing heat shrink boots follow these setting recommendations.

Recommended Setting

1. Adjust dial to low if you do not have the means to measure the temperature of the hot air gun.
2. Gradually increase temperature until the shrink boot begins to show the first subtle signs of recovery.
3. This is the heat setting to use- the lowest temperature setting that will shrink the boot.
4. A good nominal temperature to start the shrink recovery process is 100°C (212°F).
5. Heat gun settings should never exceed surface temperatures of 150°C.

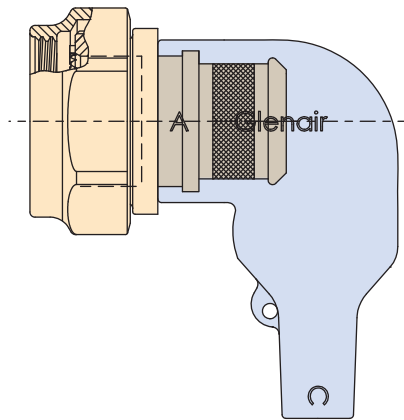

Benefits of Slowing Recovery

1. Allows time for proper placement and orientation of the shrink boot as it begins to recover.
2. Allows for a controlled shrink- starting at end marked 'A' and progressing to the end marked 'C' of the boot.
3. Eliminates potential for heat damage to the composite material or to the plating.
4. Reduces likelihood of heat gun settings exceeding surface temperatures of 150°C.

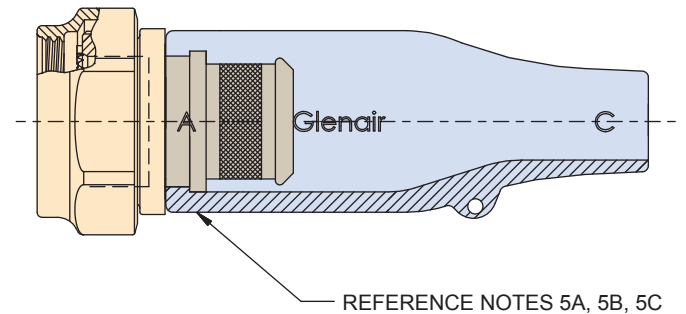

Notes

1. Increasing heat for larger boots should be gradual.
2. Use the lowest temperature setting that will shrink the boot.

**SERIES 77
ENVIRONMENTAL
SHRINK BOOTS**



Glenair Environmental Shrink Boots Now TACOM Approved, In-Stock and Ready for Immediate Shipment

High-performance Series 77 "Full Nelson" environmental shrink boots manufactured by Glenair in Glendale, California are now approved by the US Army Tank-Automotive Command (TACOM). Manufactured from high-temperature crosslinked elastomeric polymer material and/or caustic chemical-resistant Viton polymer, Glenair straight and right angle long-tail shrink boots, Y and T transitions, convoluted strain-relief boots and heat-shrinkable adapter shims have been added to the following source control documentation:

Glenair Series 77 "Full Nelson" TACOM APPROVED Shrink Boots

Description	Military Part Number	Glenair Part Number	Raychem Part Number	Hellermann Part Number	Description	Military Part Number	Glenair Part Number	Raychem Part Number	Hellermann Part Number
Heat Shrinkable Low Profile 3-Entry "Y" Transition	12273148-1**	770-009Y*05	381A301-**	492H412-*	Heat Shrinkable Straight Lipped 2-Entry Long Tail Boot	12273147-1**	770-020S*02	202F211-**	313F322-*
	12273148-2**	770-009Y*06	381A302-**	492H413-*		12273147-2**	770-020S*03	202F221-**	313F332-*
	12273148-3**	770-009Y*07-01	381A303-*01	492H414-*01		12273147-3**	770-020S*04	202F232-**	313F343-*
	12273148-4**	770-009Y*08-01	381A304-*01	492H415-*01		12273147-4**	770-020S*05	202F242-**	313F353-*
	12273148-5**	770-009Y*07	381A303-**	—		12273147-5**	770-020S*06	202F253-**	313F364-*
Heat Shrinkable Low Profile 3-Entry "T" Transition	12273162-1**	770-012T*01	301A511-**	412H622-*	12273147-6**	770-020S*07	202F263-**	313F374-*	
	12273162-2**	770-012T*02	301A512-**	412H623-*	12273147-7**	770-020S*08	202F274-**	313F385-*	
	12273162-3**	770-012T*03	301A513-**	412H624-*	Heat Shrinkable 90° Lipped 2-Entry Long Tail Boot	12273176-1**	770-021A*02	222F211-**	333F322-*
	12273162-4**	770-012T*04	301A514-**	412H625-*		12273176-2**	770-021A*03	222F221-**	333F332-*
12273163-1**	770-014*09	462A421-**	573H532-*	12273176-3**		770-021A*04	222F232-**	333F343-*	
12273163-2**	770-014*10	462A422-**	573H533-*	12273176-4**		770-021A*05	222F242-**	333F353-*	
12273163-3**	770-014*11	462A423-**	573H534-*	12273176-5**		770-021A*06	222F253-**	333F364-*	
Heat Shrinkable Adapter Shim Boot	12273163-4**	770-014*12	462A424-**	573H535-*	12273176-6**	770-021A*07	222F263-**	333F374-*	
	12273164-1**	770-019SB*01	202E334-**	313E445-*	12273176-7**	770-021A*08	222F274-**	333F385-*	
	12273164-2**	770-019SB*02	202E344-**	313E455-*					
Heat Shrinkable Convoluted Strain Relief 2-Entry Boot	12273164-3**	770-019SB*03	202E336-**	313E447-*					
	12273164-4**	770-019SB*04	202E346-**	313E457-*					
	12273242-1**	770-022C*01	202C611-**	313C722-9					
	12273242-2**	770-022C*02	202C621-**	313C732-9					
	12273242-3**	770-022C*03	202C632-**	313C743-9					
	12273242-4**	770-022C*04	202C642-**	313C753-9					
	12273242-5**	770-022C*05	202C653-**	313C764-9					
	12273242-6**	—	202G621-**	—					
	12273242-7**	—	202G632-**	—					
12273242-8**	—	202C642-**	—						
12273242-9**	—	202C653-**	—						



For more information contact Glenair at **818-247-6000** or visit our website at www.glenair.com

SERIES 77 Part Number Index



310-001G-8	770-003BC-36	770-031A.....E-12
310-017 G-31	770-003SC-6	770-031SE-10
310-034 G-10	770-004SC-10	770-035F-22
310-045 G-30	770-005A D-10	770-036F-24
310-055H-4	770-005SD-4	770-037F-26
310-057 H-16	770-006AC-28	770-038F-28
310-058H-6	770-006SC-12	809A060.....E-16
311-001 G-12	770-007AC-32	809B060.....E-18
317-102H-4	770-007SC-16	809S060E-14
319-001 G-14	770-008SC-18	809SL060.....E-20
319-044 G-16	770-009 F-4 and F-6	809SU060E-22
319-183 H-18	770-010 F-8	AS85049/59 G-21
319-216H-8	770-011 F-16	AS85049/60-1..... G-20
380-132 G-32	770-012F-18	AS85049/60-1..... G-22
440-069 G-18	770-013F-10	AS85049/60-2G..... G-23
440-144 G-33	770-014F-12	AS85049/60-2G..... G-23
443-033 H-20	770-015F-14	AS85049/62 G-24
443-040 H-10	770-018SC-20	AS85049/69 G-25
447-325 G-35	770-019SD-6	M83723/27M G-20
630-022 G-26	770-020SC-14	MS31358 G-22
630-101 H-12	770-021AC-30	MS3416-G G-23
630-103 H-22	770-022CC-22	MS38999/2 G-24
770-001AC-24	770-023F-20	MS85049/140..... B-2, B-4, B-6, B-8
770-001BC-34	770-027SD-8	MS85049/141..... B-10, B-12, B-14
770-001SC-4	770-028S E-4	MS85049/142..... B-16, B-18, B-20
770-002SC-8	770-029S E-6	
770-003AC-26	770-030 E-8	



Tyco to Glenair Part Number Cross Reference

Tyco Part Number	Glenair Part Number
202A111-100/180-0	770-005S202W2
202A111-100/86-0	770-005S202W1
202A111-100-0	770-005S202
202A111-25/225-0	770-005S102R
202A111-25/42-0	770-005S102W2
202A111-25/86-0	770-005S102W1
202A111-25-0	770-005S102
202A111-3/42-0	770-005S702W2
202A111-3/86-0	770-005S702W1
202A111-3/86-0	770-005S702W1
202A111-3-0	770-005S702
202A111-4/180-0	770-005S302W2
202A111-4/42-0	770-005S302W2
202A111-4/86-0	770-005S302W1
202A111-4/86-0	770-005S302W1
202A111-4-0	770-005S302
202A121-100/180-0	770-005S203W2
202A121-100/86-0	770-005S203W1
202A121-100/86-0	770-005S203W1
202A121-100/86-0	770-005S203W1
202A121-100-0	770-005S203
202A121-25/225-0	770-005S103R
202A121-25/42-0	770-005S103W2
202A121-25/86-0	770-005S103W1
202A121-25-0	770-005S103
202A121-3/42-0	770-005S703W2
202A121-3/86-0	770-005S703W1
202A121-3/86-0	770-005S703W1
202A121-3-0	770-005S703
202A121-4/180-0	770-005S303W2
202A121-4/42-0	770-005S303W2
202A121-4/86-0	770-005S303W1
202A121-4-0	770-005S303

Tyco Part Number	Glenair Part Number
202A132-100/180-0	770-005S204W2
202A132-100/86-0	770-005S204W1
202A132-100/86-0	770-005S204W1
202A132-100/86-0	770-005S204W1
202A132-100-0	770-005S204
202A132-25/225-0	770-005S104R
202A132-25/42-0	770-005S104W2
202A132-25/86-0	770-005S104W1
202A132-25/86-0	770-005S104W1
202A132-25/86-0	770-005S104W1
202A132-25-0	770-005S104
202A132-3/42-0	770-005S704W2
202A132-3/86-0	770-005S704W1
202A132-3/86-0	770-005S704W1
202A132-3-0	770-005S704
202A132-4/180-0	770-005S304W2
202A132-4/42-0	770-005S304W2
202A132-4/42-0	770-005S304W2
202A132-4/86-0	770-005S304W1
202A132-4/86-0	770-005S304W1
202A132-4-0	770-005S304
202A142-100/180-0	770-005S205W2
202A142-100/86-0	770-005S205W1
202A142-100-0	770-005S205
202A142-25/225-0	770-005S105R
202A142-25/42-0	770-005S105W2
202A142-25/86-0	770-005S105W1
202A142-25-0	770-005S105
202A142-3/42-0	770-005S705W2
202A142-3/180-0	770-005S705W2
202A142-3/86-0	770-005S705W1
202A142-3/86-0	770-005S705W1
202A142-3-0	770-005S705



Tyco to Glenair Part Number Cross Reference

Tyco Part Number	Glenair Part Number
202A142-4/180-0	770-005S305W2
202A142-4/42-0	770-005S305W2
202A142-4/86-0	770-005S305W1
202A142-4/86-0	770-005S305W1
202A142-4-0	770-005S305
202A153-100/180-0	770-005S206W2
202A153-100/42-0	770-005S206W2
202A153-100/86-0	770-005S206W1
202A153-100/86-0	770-005S206W1
202A153-100/86-0	770-005S206W1
202A153-100-0	770-005S206
202A153-25/225-0	770-005S106R
202A153-25/42-0	770-005S106W2
202A153-25/180-0	770-005S106W2
202A153-25/86-0	770-005S106W1
202A153-25/86-0	770-005S106W1
202A153-25/86-0	770-005S106W1
202A153-25-0	770-005S106
202A153-3/42-0	770-005S706W2
202A153-3/180-0	770-005S706W2
202A153-3/86-0	770-005S706W1
202A153-3/86-0	770-005S706W1
202A153-3-0	770-005S706
202A153-4/180-0	770-005S306W2
202A153-4/42-0	770-005S306W2
202A153-4/86-0	770-005S306W1
202A153-4/86-0	770-005S306W1
202A153-4-0	770-005S306
202A163-100/180-0	770-005S207W2
202A163-100/86-0	770-005S207W1
202A163-100/86-0	770-005S207W1
202A163-100/86-0	770-005S207W1
202A163-100-0	770-005S207

Tyco Part Number	Glenair Part Number
202A163-25/225-0	770-005S107R
202A163-25/42-0	770-005S107W2
202A163-25/86-0	770-005S107W1
202A163-25/86-0	770-005S107W1
202A163-25/86-0	770-005S107W1
202A163-25-0	770-005S107
202A163-3/42-0	770-005S707W2
202A163-3/180-0	770-005S707W2
202A163-3/86-0	770-005S707W1
202A163-3/86-0	770-005S707W1
202A163-3-0	770-005S707
202A163-4/180-0	770-005S307W2
202A163-4/42-0	770-005S307W2
202A163-4/86-0	770-005S307W1
202A163-4/86-0	770-005S307W1
202A163-4-0	770-005S307
202A174-100/180-0	770-005S208W2
202A174-100/86-0	770-005S208W1
202A174-100/86-0	770-005S208W1
202A174-100/86-0	770-005S208W1
202A174-100-0	770-005S208
202A174-25/225-0	770-005S108R
202A174-25/42-0	770-005S108W2
202A174-25/86-0	770-005S108W1
202A174-25/86-0	770-005S108W1
202A174-25/86-0	770-005S108W1
202A174-25-0	770-005S108
202A174-3/42-0	770-005S708W2
202A174-3/86-0	770-005S708W1
202A174-3/86-0	770-005S708W1
202A174-3-0	770-005S708
202A174-4/180-0	770-005S308W2
202A174-4/42-0	770-005S308W2





Tyco to Glenair Part Number Cross Reference

Tyco Part Number	Glenair Part Number
202A174-4/86-0	770-005S308W1
202A174-4/86-0	770-005S308W1
202A174-4-0	770-005S308
202A185-100/180-0	770-005S209W2
202A185-100/86-0	770-005S209W1
202A185-100/86-0	770-005S209W1
202A185-100/86-0	770-005S209W1
202A185-100-0	770-005S209
202A185-25/225-0	770-005S109R
202A185-25/42-0	770-005S109W2
202A185-25/86-0	770-005S109W1
202A185-25/86-0	770-005S109W1
202A185-25/86-0	770-005S109W1
202A185-25-0	770-005S109
202A185-3/42-0	770-005S709W2
202A185-3/86-0	770-005S709W1
202A185-3/86-0	770-005S709W1
202A185-3-0	770-005S709
202A185-4/180-0	770-005S309W2
202A185-4/86-0	770-005S309W1
202A185-4/86-0	770-005S309W1
202A185-4-0	770-005S309
202A196-100/180-0	770-005S210W2
202A196-100/86-0	770-005S210W1
202A196-100/86-0	770-005S210W1
202A196-100/86-0	770-005S210W1
202A196-100-0	770-005S210
202A196-25/225-0	770-005S110R
202A196-25/42-0	770-005S110W2
202A196-25/86-0	770-005S110W1
202A196-25/86-0	770-005S110W1
202A196-25/86-0	770-005S110W1
202A196-25-0	770-005S110

Tyco Part Number	Glenair Part Number
202A196-3/42-0	770-005S710W2
202A196-3/86-0	770-005S710W1
202A196-3/86-0	770-005S710W1
202A196-3/86-0	770-005S710W1
202A196-3-0	770-005S710
202A196-4/180-0	770-005S310W2
202A196-4/86-0	770-005S310W1
202A196-4/86-0	770-005S310W1
202A196-4-0	770-005S310
202C611-50-0	770-022C501
202C611-50/86-0	770-022C501W1
202C611-50/86-0	770-022C501W1
202C611-51/164-0	770-022C601W3
202C611-51/86-0	770-022C601W1
202C611-51/86-0	770-022C601W1
202C611-51-0	770-022C601
202C611-71/180-0	770-022C701W2
202C611-71/42-0	770-022C701W2
202C611-71/86-0	770-022C701W1
202C611-71-0	770-022C701
202C621-50-0	770-022C502
202C621-50/86-0	770-022C502W1
202C621-50/86-0	770-022C502W1
202C621-51/164-0	770-022C602W3
202C621-51/86-0	770-022C602W1
202C621-51/86-0	770-022C602W1
202C621-51-0	770-022C602
202C621-71/180-0	770-022C702W2
202C621-71/42-0	770-022C702W2
202C621-71/86-0	770-022C702W1
202C621-71-0	770-022C702
202C632-50-0	770-022C503
202C632-50/86-0	770-022C503W1



Tyco to Glenair Part Number Cross Reference

Tyco Part Number	Glenair Part Number
202C632-50/86-0	770-022C503W1
202C632-51/164-0	770-022C603W3
202C632-51/86-0	770-022C603W1
202C632-51/86-0	770-022C603W1
202C632-51-0	770-022C603
202C632-71/180-0	770-022C703W2
202C632-71/42-0	770-022C703W2
202C632-71/86-0	770-022C703W1
202C632-71-0	770-022C703
202C642-50-0	770-022C504
202C642-50/86-0	770-022C504W1
202C642-50/86-0	770-022C504W1
202C642-51/164-0	770-022C604W3
202C642-51/86-0	770-022C604W1
202C642-51/86-0	770-022C604W1
202C642-51-0	770-022C604
202C642-71/180-0	770-022C704W2
202C642-71/42-0	770-022C704W2
202C642-71/86-0	770-022C704W1
202C642-71-0	770-022C704
202C653-50-0	770-022C505
202C653-50/86-0	770-022C505W1
202C653-50/86-0	770-022C505W1
202C653-51/164-0	770-022C605W3
202C653-51/86-0	770-022C605W1
202C653-51/86-0	770-022C605W1
202C653-51-0	770-022C605
202C653-71/180-0	770-022C705W2
202C653-71/42-0	770-022C705W2
202C653-71/86-0	770-022C705W1
202C653-71-0	770-022C705
202C663-50/86-0	770-022C506W1
202C663-50/86-0	770-022C506W1

Tyco Part Number	Glenair Part Number
202C663-50-0	770-022C506
202C663-51/164-0	770-022C606W3
202C663-51/86-0	770-022C606W1
202C663-51/86-0	770-022C606W1
202C663-51-0	770-022C606
202C663-71/180-0	770-022C706W2
202C663-71/42-0	770-022C706W2
202C663-71/86-0	770-022C706W1
202C663-71-0	770-022C706
202D111-100/180-0	770-003S202W2
202D111-100/86-0	770-003S202W1
202D111-100/86-0	770-003S202W1
202D111-100/86-0	770-003S202W1
202D111-100-0	770-003S202
202D111-25/225-0	770-003S102R
202D111-25/42-0	770-003S102W2
202D111-25/180-0	770-003S102W2
202D111-25/86-0	770-003S102W1
202D111-25/86-0	770-003S102W1
202D111-25/86-0	770-003S102W1
202D111-25-0	770-003S102
202D111-3/180-0	770-003S702W2
202D111-3/42-0	770-003S702W2
202D111-3/86-0	770-003S702W1
202D111-3/86-0	770-003S702W1
202D111-3-0	770-003S702
202D111-4/180-0	770-003S302W2
202D111-4/42-0	770-003S302W2
202D111-4/86-0	770-003S302W1
202D111-4/86-0	770-003S302W1
202D111-4-0	770-003S302
202D121-100/180-0	770-003S203W2
202D121-100/86-0	770-003S203W1





Tyco to Glenair Part Number Cross Reference

Tyco Part Number	Glenair Part Number
202D121-100/86-0	770-003S203W1
202D121-100/86-0	770-003S203W1
202D121-100-0	770-003S203
202D121-100-07-0	770-004S203
202D121-25/225-0	770-003S103R
202D121-25/42-0	770-003S103W2
202D121-25/86-0	770-003S103W1
202D121-25/86-0	770-003S103W1
202D121-25/86-0	770-003S103W1
202D121-25-0	770-003S103
202D121-25-07-0	770-004S103
202D121-3/180-0	770-003S703W2
202D121-3/42-0	770-003S703W2
202D121-3/86-0	770-003S703W1
202D121-3/86-0	770-003S703W1
202D121-3-0	770-003S703
202D121-3-07-0	770-004S703
202D121-4/180-0	770-003S303W2
202D121-4/42-0	770-003S303W2
202D121-4/86-0	770-003S303W1
202D121-4/86-0	770-003S303W1
202D121-4-0	770-003S303
202D121-4-07-0	770-004S303
202D132-100/180-0	770-003S204W2
202D132-100/86-0	770-003S204W1
202D132-100/86-0	770-003S204W1
202D132-100/86-0	770-003S204W1
202D132-100-0	770-003S204
202D132-100-07-0	770-004S204
202D132-25/225-0	770-003S104R
202D132-25/42-0	770-003S104W2
202D132-25/86-0	770-003S104W1
202D132-25/86-0	770-003S104W1

Tyco Part Number	Glenair Part Number
202D132-25/86-0	770-003S104W1
202D132-25-0	770-003S104
202D132-25-07-0	770-004S104
202D132-3/180-0	770-003S704W2
202D132-3/42-0	770-003S704W2
202D132-3/86-0	770-003S704W1
202D132-3/86-0	770-003S704W1
202D132-3-0	770-003S704
202D132-3-07-0	770-004S704
202D132-4/180-0	770-003S304W2
202D132-4/42-0	770-003S304W2
202D132-4/86-0	770-003S304W1
202D132-4/86-0	770-003S304W1
202D132-4-0	770-003S304
202D132-4-07-0	770-004S304
202D142-100/180-0	770-003S205W2
202D142-100/86-0	770-003S205W1
202D142-100/86-0	770-003S205W1
202D142-100/86-0	770-003S205W1
202D142-100-0	770-003S205
202D142-100-07-0	770-004S205
202D142-25/225-0	770-003S105R
202D142-25/42-0	770-003S105W2
202D142-25/86-0	770-003S105W1
202D142-25/86-0	770-003S105W1
202D142-25/86-0	770-003S105W1
202D142-25-0	770-003S105
202D142-25-07-0	770-004S105
202D142-3/180-0	770-003S705W2
202D142-3/42-0	770-003S705W2
202D142-3/86-0	770-003S705W1
202D142-3/86-0	770-003S705W1
202D142-3-0	770-003S705



Tyco to Glenair Part Number Cross Reference

Tyco Part Number	Glenair Part Number
202D142-3-07-0	770-004S705
202D142-4/180-0	770-003S305W2
202D142-4/42-0	770-003S305W2
202D142-4/86-0	770-003S305W1
202D142-4/86-0	770-003S305W1
202D142-4-0	770-003S305
202D142-4-07-0	770-004S305
202D153-100/180-0	770-003S206W2
202D153-100/86-0	770-003S206W1
202D153-100/86-0	770-003S206W1
202D153-100/86-0	770-003S206W1
202D153-100-0	770-003S206
202D153-100-07-0	770-004S206
202D153-25/225-0	770-003S106R
202D153-25/42-0	770-003S106W2
202D153-25/86-0	770-003S106W1
202D153-25/86-0	770-003S106W1
202D153-25/86-0	770-003S106W1
202D153-25-0	770-003S106
202D153-25-07-0	770-004S106
202D153-3/180-0	770-003S706W2
202D153-3/42-0	770-003S706W2
202D153-3/86-0	770-003S706W1
202D153-3/86-0	770-003S706W1
202D153-3-0	770-003S706
202D153-3-07-0	770-004S706
202D153-4/180-0	770-003S306W2
202D153-4/42-0	770-003S306W2
202D153-4/86-0	770-003S306W1
202D153-4/86-0	770-003S306W1
202D153-4-0	770-003S306
202D153-4-07-0	770-004S306
202D163-100/180-0	770-003S207W2

Tyco Part Number	Glenair Part Number
202D163-100/86-0	770-003S207W1
202D163-100/86-0	770-003S207W1
202D163-100/86-0	770-003S207W1
202D163-100-0	770-003S207
202D163-25/225-0	770-003S107R
202D163-25/42-0	770-003S107W2
202D163-25/86-0	770-003S107W1
202D163-25-0	770-003S107
202D163-3/180-0	770-003S707W2
202D163-3/42-0	770-003S707W2
202D163-3/86-0	770-003S707W1
202D163-3/86-0	770-003S707W1
202D163-3-0	770-003S707
202D163-4/180-0	770-003S307W2
202D163-4/42-0	770-003S307W2
202D163-4/86-0	770-003S307W1
202D163-4/86-0	770-003S307W1
202D163-4-0	770-003S307
202D174-100	770-003S208
202D174-100/180-0	770-003S208W2
202D174-100/86-0	770-003S208W1
202D174-100/86-0	770-003S208W1
202D174-100/86-0	770-003S208W1
202D174-100-07-0	770-004S208
202D174-25/225-0	770-003S108R
202D174-25/42-0	770-003S108W2
202D174-25/86-0	770-003S108W1
202D174-25/86-0	770-003S108W1
202D174-25/86-0	770-003S108W1
202D174-25-0	770-003S108
202D174-25-07-0	770-004S108
202D174-3/180-0	770-003S708W2
202D174-3/42-0	770-003S708W2





Tyco to Glenair Part Number Cross Reference

Tyco Part Number	Glenair Part Number
202D174-3/86-0	770-003S708W1
202D174-3/86-0	770-003S708W1
202D174-3-0	770-003S708
202D174-3-07-0	770-004S708
202D174-4/180-0	770-003S308W2
202D174-4/42-0	770-003S308W2
202D174-4/86-0	770-003S308W1
202D174-4/86-0	770-003S308W1
202D174-4-0	770-003S308
202D174-4-07-0	770-004S308
202D185-100/180-0	770-003S209W2
202D185-100/86-0	770-003S209W1
202D185-100/86-0	770-003S209W1
202D185-100/86-0	770-003S209W1
202D185-100-0	770-003S209
202D185-25/225-0	770-003S109R
202D185-25/42-0	770-003S109W2
202D185-25/86-0	770-003S109W1
202D185-25/86-0	770-003S109W1
202D185-25/86-0	770-003S109W1
202D185-25-0	770-003S109
202D185-3/180-0	770-003S709W2
202D185-3/42-0	770-003S709W2
202D185-3/86-0	770-003S709W1
202D185-3/86-0	770-003S709W1
202D185-3-0	770-003S709
202D185-4/180-0	770-003S309W2
202D185-4/42-0	770-003S309W2
202D185-4/86-0	770-003S309W1
202D185-4/86-0	770-003S309W1
202D185-4-0	770-003S309
202D196-100/180-0	770-003S210W2
202D196-100/86-0	770-003S210W1

Tyco Part Number	Glenair Part Number
202D196-100-0	770-003S210
202D196-25/42-0	770-003S110W2
202D196-25/86-0	770-003S110W1
202D196-25-0	770-003S110
202D196-3/180-0	770-003S710W2
202D196-3/42-0	770-003S710W2
202D196-3/86-0	770-003S710W1
202D196-3-0	770-003S710
202D196-4/180-0	770-003S310W2
202D196-4/42-0	770-003S310W2
202D196-4/86-0	770-003S310W1
202D196-4-0	770-003S310
202D211-100/180-0	770-006S202W2
202D211-100/86-0	770-006S202W1
202D211-100/86-0	770-006S202W1
202D211-100/86-0	770-006S202W1
202D211-100-0	770-006S202
202D211-100-22-0	770-006S202-6725
202D211-25/225-0	770-006S102R
202D211-25/42-0	770-006S102W2
202D211-25/86-0	770-006S102W1
202D211-25/86-0	770-006S102W1
202D211-25/86-0	770-006S102W1
202D211-25-0	770-006S102
202D211-25-22-0	770-006S102-6725
202D211-3/180-0	770-006S702W2
202D211-3/42-0	770-006S702W2
202D211-3/86-0	770-006S702W1
202D211-3/86-0	770-006S702W1
202D211-3-0	770-006S702
202D211-3-22-0	770-006S702-6725
202D211-4/180-0	770-006S302W2
202D211-4/42-0	770-006S302W2



Tyco to Glenair Part Number Cross Reference

Tyco Part Number	Glenair Part Number
202D211-4/86-0	770-006S302W1
202D211-4/86-0	770-006S302W1
202D211-4-0	770-006S302
202D211-4-22-0	770-006S302-6725
202D221-100/180-0	770-006S203W2
202D221-100/86-0	770-006S203W1
202D221-100/86-0	770-006S203W1
202D221-100/86-0	770-006S203W1
202D221-100-0	770-006S203
202D221-25/225-0	770-006S103R
202D221-25/42-0	770-006S103W2
202D221-25/86-0	770-006S103W1
202D221-25/86-0	770-006S103W1
202D221-25/86-0	770-006S103W1
202D221-25-0	770-006S103
202D221-3/180-0	770-006S703W2
202D221-3/42-0	770-006S703W2
202D221-3/86-0	770-006S703W1
202D221-3/86-0	770-006S703W1
202D221-3-0	770-006S703
202D221-4/180-0	770-006S303W2
202D221-4/42-0	770-006S303W2
202D221-4/86-0	770-006S303W1
202D221-4/86-0	770-006S303W1
202D221-4-0	770-006S303
202D232-100/180-0	770-006S204W2
202D232-100/86-0	770-006S204W1
202D232-100/86-0	770-006S204W1
202D232-100/86-0	770-006S204W1
202D232-100-0	770-006S204
202D232-100-22-0	770-006S204-6726
202D232-25/225-0	770-006S104R
202D232-25/42-0	770-006S104W2

Tyco Part Number	Glenair Part Number
202D232-25/86-0	770-006S104W1
202D232-25/86-0	770-006S104W1
202D232-25/86-0	770-006S104W1
202D232-25-0	770-006S104
202D232-25-22-0	770-006S104-6726
202D232-3/180-0	770-006S704W2
202D232-3/42-0	770-006S704W2
202D232-3/86-0	770-006S704W1
202D232-3/86-0	770-006S704W1
202D232-3-0	770-006S704
202D232-3-22-0	770-006S704-6726
202D232-4/180-0	770-006S304W2
202D232-4/42-0	770-006S304W2
202D232-4/86-0	770-006S304W1
202D232-4/86-0	770-006S304W1
202D232-4-0	770-006S304
202D232-4-22-0	770-006S304-6726
202D242-100/180-0	770-006S205W2
202D242-100/86-0	770-006S205W1
202D242-100/86-0	770-006S205W1
202D242-100/86-0	770-006S205W1
202D242-100-0	770-006S205
202D242-100-22-0	770-006S205-6727
202D242-25/225-0	770-006S105R
202D242-25/42-0	770-006S105W2
202D242-25/86-0	770-006S105W1
202D242-25/86-0	770-006S105W1
202D242-25/86-0	770-006S105W1
202D242-25-0	770-006S105
202D242-25-22-0	770-006S105-6727
202D242-3/180-0	770-006S705W2
202D242-3/42-0	770-006S705W2
202D242-3/86-0	770-006S705W1





Tyco to Glenair Part Number Cross Reference

Tyco Part Number	Glenair Part Number
202D242-3/86-0	770-006S705W1
202D242-3-0	770-006S705
202D242-3-22-0	770-006S705-6727
202D242-4/180-0	770-006S305W2
202D242-4/42-0	770-006S305W2
202D242-4/86-0	770-006S305W1
202D242-4/86-0	770-006S305W1
202D242-4-0	770-006S305
202D242-4-22-0	770-006S305-6727
202D253-100/180-0	770-006S206W2
202D253-100/86-0	770-006S206W1
202D253-100/86-0	770-006S206W1
202D253-100/86-0	770-006S206W1
202D253-100-0	770-006S206
202D253-25/225-0	770-006S106R
202D253-25/42-0	770-006S106W2
202D253-25/86-0	770-006S106W1
202D253-25/86-0	770-006S106W1
202D253-25/86-0	770-006S106W1
202D253-25-0	770-006S106
202D253-3/180-0	770-006S706W2
202D253-3/42-0	770-006S706W2
202D253-3/86-0	770-006S706W1
202D253-3/86-0	770-006S706W1
202D253-3-0	770-006S706
202D253-4/180-0	770-006S306W2
202D253-4/42-0	770-006S306W2
202D253-4/86-0	770-006S306W1
202D253-4/86-0	770-006S306W1
202D253-4-0	770-006S306
202D263-100/180-0	770-006S207W2
202D263-100/86-0	770-006S207W1
202D263-100/86-0	770-006S207W1

Tyco Part Number	Glenair Part Number
202D263-100/86-0	770-006S207W1
202D263-100-0	770-006S207
202D263-100-22-0	770-006S207-6728
202D263-25/225-0	770-006S107R
202D263-25/42-0	770-006S107W2
202D263-25/86-0	770-006S107W1
202D263-25/86-0	770-006S107W1
202D263-25/86-0	770-006S107W1
202D263-25-0	770-006S107
202D263-25-22-0	770-006S107-6728
202D263-3/180-0	770-006S707W2
202D263-3/42-0	770-006S707W2
202D263-3/86-0	770-006S707W1
202D263-3/86-0	770-006S707W1
202D263-3-0	770-006S707
202D263-3-22-0	770-006S707-6728
202D263-4/180-0	770-006S307W2
202D263-4/42-0	770-006S307W2
202D263-4/86-0	770-006S307W1
202D263-4/86-0	770-006S307W1
202D263-4-0	770-006S307
202D263-4-22-0	770-006S307-6728
202D274-100/180-0	770-006S208W2
202D274-100/86-0	770-006S208W1
202D274-100/86-0	770-006S208W1
202D274-100/86-0	770-006S208W1
202D274-100-0	770-006S208
202D274-25/225-0	770-006S108R
202D274-25/42-0	770-006S108W2
202D274-25/86-0	770-006S108W1
202D274-25/86-0	770-006S108W1
202D274-25/86-0	770-006S108W1
202D274-25-0	770-006S108



Tyco to Glenair Part Number Cross Reference

Tyco Part Number	Glenair Part Number
202D274-3/180-0	770-006S708W2
202D274-3/42-0	770-006S708W2
202D274-3/86-0	770-006S708W1
202D274-3/86-0	770-006S708W1
202D274-3-0	770-006S708
202D274-4/42-0	770-006S308W2
202D274-4-0	770-006S308
202D285-100/180-0	770-006S209W2
202D285-100/86-0	770-006S209W1
202D285-100/86-0	770-006S209W1
202D285-100/86-0	770-006S209W1
202D285-100-0	770-006S209
202D285-25/225-0	770-006S109R
202D285-25/42-0	770-006S109W2
202D285-25/86-0	770-006S109W1
202D285-25/86-0	770-006S109W1
202D285-25/86-0	770-006S109W1
202D285-25-0	770-006S109
202D285-3/180-0	770-006S709W2
202D285-3/42-0	770-006S709W2
202D285-3/86-0	770-006S709W1
202D285-3/86-0	770-006S709W1
202D285-3-0	770-006S709
202D285-4/180-0	770-006S309W2
202D285-4/42-0	770-006S309W2
202D285-4/86-0	770-006S309W1
202D285-4/86-0	770-006S309W1
202D285-4-0	770-006S309
202D296-100/180-0	770-006S210W2
202D296-100/86-0	770-006S210W1
202D296-100-0	770-006S210
202D296-100-22-0	770-006S210-6729
202D296-25/225-0	770-006S110R

Tyco Part Number	Glenair Part Number
202D296-25/42-0	770-006S110W2
202D296-25/86-0	770-006S110W1
202D296-25-0	770-006S110
202D296-25-22-0	770-006S110-6729
202D296-3/180-0	770-006S710W2
202D296-3/42-0	770-006S710W2
202D296-3/86-0	770-006S710W1
202D296-3-0	770-006S710
202D296-3-22-0	770-006S710-6729
202D296-4/180-0	770-006S310W2
202D296-4/42-0	770-006S310W2
202D296-4/86-0	770-006S310W1
202D296-4-0	770-006S310
202D296-4-22-0	770-006S310-6729
202D299-100/180-0	770-006S211W2
202D299-100/86-0	770-006S211W1
202D299-100-0	770-006S211
202D299-25/225-0	770-006S111R
202D299-25/42-0	770-006S111W2
202D299-25/86-0	770-006S111W1
202D299-25-0	770-006S111
202D299-3/180-0	770-006S711W2
202D299-3/42-0	770-006S711W2
202D299-3/86-0	770-006S711W1
202D299-3-0	770-006S711
202D299-4/180-0	770-006S311W2
202D299-4/42-0	770-006S311W2
202D299-4/86-0	770-006S311W1
202D299-4-0	770-006S311
202D921-100/180-0	770-007S203W2
202D921-100/86-0	770-007S203W1
202D921-100/86-0	770-007S203W1
202D921-100/86-0	770-007S203W1





Tyco to Glenair Part Number Cross Reference

Tyco Part Number	Glenair Part Number
202D921-100-0	770-007S203
202D921-25/225-0	770-007S103R
202D921-25/42-0	770-007S103W2
202D921-25/86-0	770-007S103W1
202D921-25/86-0	770-007S103W1
202D921-25/86-0	770-007S103W1
202D921-25-0	770-007S103
202D921-3/180-0	770-007S703W2
202D921-3/42-0	770-007S703W2
202D921-3/86-0	770-007S703W1
202D921-3/86-0	770-007S703W1
202D921-3-0	770-007S703
202D921-4/180-0	770-007S303W2
202D921-4/42-0	770-007S303W2
202D921-4/86-0	770-007S303W1
202D921-4/86-0	770-007S303W1
202D921-4-0	770-007S303
202D932-100/180-0	770-007S204W2
202D932-100/86-0	770-007S204W1
202D932-100/86-0	770-007S204W1
202D932-100/86-0	770-007S204W1
202D932-100-0	770-007S204
202D932-25/225-0	770-007S104R
202D932-25/42-0	770-007S104W2
202D932-25/86-0	770-007S104W1
202D932-25/86-0	770-007S104W1
202D932-25/86-0	770-007S104W1
202D932-25-0	770-007S104
202D932-3/180-0	770-007S704W2
202D932-3/42-0	770-007S704W2
202D932-3/86-0	770-007S704W1
202D932-3/86-0	770-007S704W1
202D932-3-0	770-007S704

Tyco Part Number	Glenair Part Number
202D932-4/180-0	770-007S304W2
202D932-4/42-0	770-007S304W2
202D932-4/86-0	770-007S304W1
202D932-4/86-0	770-007S304W1
202D932-4/86-0	770-007S304W1
202D932-4-0	770-007S304
202D953-100/180-0	770-007S206W2
202D953-100/86-0	770-007S206W1
202D953-100/86-0	770-007S206W1
202D953-100/86-0	770-007S206W1
202D953-100-0	770-007S206
202D953-25/225-0	770-007S106R
202D953-25/42-0	770-007S106W2
202D953-25/86-0	770-007S106W1
202D953-25/86-0	770-007S106W1
202D953-25/86-0	770-007S106W1
202D953-25-0	770-007S106
202D953-3/180-0	770-007S706W2
202D953-3/42-0	770-007S706W2
202D953-3/86-0	770-007S706W1
202D953-3/86-0	770-007S706W1
202D953-3-0	770-007S706
202D953-4/180-0	770-007S306W2
202D953-4/42-0	770-007S306W2
202D953-4/86-0	770-007S306W1
202D953-4/86-0	770-007S306W1
202D953-4-0	770-007S306
202D963-100/180-0	770-007S207W2
202D963-100/86-0	770-007S207W1
202D963-100/86-0	770-007S207W1
202D963-100/86-0	770-007S207W1
202D963-100-0	770-007S207
202D963-25/225-0	770-007S107R



Tyco to Glenair Part Number Cross Reference

Tyco Part Number	Glenair Part Number
202D963-25/42-0	770-007S107W2
202D963-25/86-0	770-007S107W1
202D963-25/86-0	770-007S107W1
202D963-25/86-0	770-007S107W1
202D963-25-0	770-007S107
202D963-3/180-0	770-007S707W2
202D963-3/42-0	770-007S707W2
202D963-3/86-0	770-007S707W1
202D963-3/86-0	770-007S707W1
202D963-3-0	770-007S707
202D963-4/180-0	770-007S307W2
202D963-4/42-0	770-007S307W2
202D963-4/86-0	770-007S307W1
202D963-4/86-0	770-007S307W1
202D963-4-0	770-007S307
202E334-50/164-0	770-019SB501W3
202E334-50/180-0	770-019SB501W2
202E334-50/225-0	770-019SB501R
202E334-50/86-0	770-019SB501W1
202E334-50/86-0	770-019SB501W1
202E334-50/86-0	770-019SB501W1
202E334-50-0	770-019SB501
202E334-51/164-0	770-019SB601W3
202E334-51/180-0	770-019SB601W2
202E334-51/225-0	770-019SB601R
202E334-51/86-0	770-019SB601W1
202E334-51/86-0	770-019SB601W1
202E334-51/86-0	770-019SB601W1
202E334-51-0	770-019SB601
202E334-71/180-0	770-019SB701W2
202E334-71/42-0	770-019SB701W2
202E334-71/86-0	770-019SB701W1
202E334-71/86-0	770-019SB701W1

Tyco Part Number	Glenair Part Number
202E334-71/86-0	770-019SB701W1
202E334-71-0	770-019SB701
202E336-50/164-0	770-019SB502W3
202E336-50/180-0	770-019SB502W2
202E336-50/225-0	770-019SB502R
202E336-50/86-0	770-019SB502W1
202E336-50/86-0	770-019SB502W1
202E336-50/86-0	770-019SB502W1
202E336-50-0	770-019SB502
202E336-51/164-0	770-019SB602W3
202E336-51/180-0	770-019SB602W2
202E336-51/225-0	770-019SB602R
202E336-51/86-0	770-019SB602W1
202E336-51/86-0	770-019SB602W1
202E336-51/86-0	770-019SB602W1
202E336-51-0	770-019SB602
202E336-71/180-0	770-019SB702W2
202E336-71/42-0	770-019SB702W2
202E336-71/86-0	770-019SB702W1
202E336-71-0	770-019SB702
202E344-50/164-0	770-019SB503W3
202E344-50/180-0	770-019SB503W2
202E344-50/225-0	770-019SB503R
202E344-50/86-0	770-019SB503W1
202E344-50/86-0	770-019SB503W1
202E344-50/86-0	770-019SB503W1
202E344-50-0	770-019SB503
202E344-51/164-0	770-019SB603W3
202E344-51/180-0	770-019SB603W2
202E344-51/225-0	770-019SB603R
202E344-51/86-0	770-019SB603W1
202E344-51/86-0	770-019SB603W1
202E344-51/86-0	770-019SB603W1





Tyco to Glenair Part Number Cross Reference

Tyco Part Number	Glenair Part Number
202E344-51-0	770-019SB603
202E344-71/180-0	770-019SB703W2
202E344-71/42-0	770-019SB703W2
202E344-71/86-0	770-019SB703W1
202E344-71-0	770-019SB703
202E346-50/164-0	770-019SB504W3
202E346-50/180-0	770-019SB504W2
202E346-50/225-0	770-019SB504R
202E346-50/86-0	770-019SB504W1
202E346-50/86-0	770-019SB504W1
202E346-50/86-0	770-019SB504W1
202E346-50-0	770-019SB504
202E346-51/164-0	770-019SB604W3
202E346-51/180-0	770-019SB604W2
202E346-51/225-0	770-019SB604R
202E346-51/86-0	770-019SB604W1
202E346-51/86-0	770-019SB604W1
202E346-51/86-0	770-019SB604W1
202E346-51-0	770-019SB604
202E346-71/180-0	770-019SB704W2
202E346-71/42-0	770-019SB704W2
202E346-71/86-0	770-019SB704W1
202E346-71-0	770-019SB704
202F211-50-0	770-020S502
202F211-50/180-0	770-020S502W2
202F211-50/225-0	770-020S502R
202F211-50/86-0	770-020S502W1
202F211-50/86-0	770-020S502W1
202F211-50/86-0	770-020S502W1
202F211-51-0	770-020S602
202F211-51/164-0	770-020S602W3
202F211-51/180-0	770-020S602W2
202F211-51/86-0	770-020S602W1

Tyco Part Number	Glenair Part Number
202F211-51/86-0	770-020S602W1
202F211-51/86-0	770-020S602W1
202F211-51/225-0	770-020S602R
202F211-71/180	770-020S702W2
202F211-71/42-0	770-020S702W2
202F211-71/86-0	770-020S702W1
202F211-71-0	770-020S702
202F221-50/225-0	770-020S503R
202F221-50/86-0	770-020S503W1
202F221-50/86-0	770-020S503W1
202F221-50/86-0	770-020S503W1
202F221-50-0	770-020S503
202F221-50-180-0	770-020S503W2
202F221-51/164-0	770-020S603W3
202F221-51/225-0	770-020S603R
202F221-51/180-0	770-020S603W2
202F221-51/86-0	770-020S603W1
202F221-51/86-0	770-020S603W1
202F221-51/86-0	770-020S603W1
202F221-51-0	770-020S603
202F221-71/180-0	770-020S703W2
202F221-71/42-0	770-020S703W2
202F221-71/86-0	770-020S703W1
202F221-71-0	770-020S703
202F232-50/225-0	770-020S504R
202F232-50/86-0	770-020S504W1
202F232-50/86-0	770-020S504W1
202F232-50/86-0	770-020S504W1
202F232-50-0	770-020S504
202F232-50/180-0	770-020S504W2
202F232-51/164-0	770-020S604W3
202F232-51/225-0	770-020S604R
202F232-51/180-0	770-020S604W2



Tyco to Glenair Part Number Cross Reference

Tyco Part Number	Glenair Part Number
202F232-51/86-0	770-020S604W1
202F232-51/86-0	770-020S604W1
202F232-51/86-0	770-020S604W1
202F232-51-0	770-020S604
202F232-71/180-0	770-020S704W2
202F232-71/42-0	770-020S704W2
202F232-71/86-0	770-020S704W1
202F232-71-0	770-020S704
202F242-50/180-0	770-020S505W2
202F242-50/225-0	770-020S505R
202F242-50/86-0	770-020S505W1
202F242-50/86-0	770-020S505W1
202F242-50/86-0	770-020S505W1
202F242-50-0	770-020S505
202F242-51/164-0	770-020S605W3
202F242-51/225-0	770-020S605R
202F242-51/180-0	770-020S605W2
202F242-51/86-0	770-020S605W1
202F242-51/86-0	770-020S605W1
202F242-51/86-0	770-020S605W1
202F242-51-0	770-020S605
202F242-71/180-0	770-020S705W2
202F242-71/42-0	770-020S705W2
202F242-71/86-0	770-020S705W1
202F242-71-0	770-020S705
202F253-50/225-0	770-020S506R
202F253-50/86-0	770-020S506W1
202F253-50-0	770-020S506
202F253-50/180-0	770-020S506W2
202F253-51/164-0	770-020S606W3
202F253-51/180-0	770-020S606W2
202F253-51/86-0	770-020S606W1
202F253-51/86-0	770-020S606W1

Tyco Part Number	Glenair Part Number
202F253-51/86-0	770-020S606W1
202F253-51-0	770-020S606
202F253-71/180-0	770-020S706W2
202F253-71/42-0	770-020S706W2
202F253-71/86-0	770-020S706W1
202F253-71-0	770-020S706
202F263-50/180-0	770-020S507W2
202F263-50/225-0	770-020S507R
202F263-50/86-0	770-020S507W1
202F263-50/86-0	770-020S507W1
202F263-50/86-0	770-020S507W1
202F263-50-0	770-020S507
202F263-51/164-0	770-020S607W3
202F263-51/180-0	770-020S607W2
202F263-51/86-0	770-020S607W1
202F263-51/86-0	770-020S607W1
202F263-51/86-0	770-020S607W1
202F263-51-0	770-020S607
202F263-71/180-0	770-020S707W2
202F263-71/42-0	770-020S707W2
202F263-71/86-0	770-020S707W1
202F263-71-0	770-020S707
202F274-50/180-0	770-020S508W2
202F274-50/225-0	770-020S508R
202F274-50/86-0	770-020S508W1
202F274-50/86-0	770-020S508W1
202F274-50/86-0	770-020S508W1
202F274-50-0	770-020S508
202F274-51/164-0	770-020S608W3
202F274-51/180-0	770-020S608W2
202F274-51/86-0	770-020S608W1
202F274-51/86-0	770-020S608W1
202F274-51/86-0	770-020S608W1





Tyco to Glenair Part Number Cross Reference

Tyco Part Number	Glenair Part Number
202F274-51-0	770-020S608
202F274-71/180-0	770-020S708W2
202F274-71/42-0	770-020S708W2
202F274-71/86-0	770-020S708W1
202F274-71-0	770-020S708
202K121-100/180-0	770-001S203W2
202K121-100/86-0	770-001S203W1
202K121-100/86-0	770-001S203W1
202K121-100/86-0	770-001S203W1
202K121-100-0	770-001S203
202K121-100-01/180-0	770-002S203W1
202K121-100-01-0	770-002S203
202K121-25/225-0	770-001S103R
202K121-25/42-0	770-001S103W2
202K121-25/86-0	770-001S103W1
202K121-25/86-0	770-001S103W1
202K121-25/86-0	770-001S103W1
202K121-25-0	770-001S103
202K121-25-01/225-0	770-002S103R
202K121-25-01/42-0	770-002S103W2
202K121-25-01/86-0	770-002S103W1
202K121-25-01-0	770-002S103
202K121-3/180-0	770-001S703W2
202K121-3/42-0	770-001S703W2
202K121-3/86-0	770-001S703W1
202K121-3/86-0	770-001S703W1
202K121-3-0	770-001S703
202K121-3-01/180-0	770-002S703W2
202K121-3-01/42-0	770-002S703W2
202K121-3-01/86-0	770-002S703W1
202K121-3-01/86-0	770-002S703W1
202K121-3-01-0	770-002S703
202K121-4/180-0	770-001S303W2

Tyco Part Number	Glenair Part Number
202K121-4/42-0	770-001S303W2
202K121-4/86-0	770-001S303W1
202K121-4/86-0	770-001S303W1
202K121-4-0	770-001S303
202K121-4-01/42-0	770-002S303W2
202K121-4-01/42-0	770-002S303W2
202K121-4-01-0	770-002S303
202K132-100/180-0	770-001S204W2
202K132-100-0	770-001S204
202K132-100-01/180-0	770-002S204W2
202K132-100-01-0	770-002S204
202K132-25/225-0	770-001S104R
202K132-25/42-0	770-001S104W2
202K132-25/86-0	770-001S104W1
202K132-25/86-0	770-001S104W1
202K132-25/86-0	770-001S104W1
202K132-25-0	770-001S104
202K132-25-01/225-0	770-002S104R
202K132-25-01/42-0	770-002S104W2
202K132-25-01/86-0	770-002S104W1
202K132-25-01-0	770-002S104
202K132-3/180-0	770-001S704W2
202K132-3/42-0	770-001S704W2
202K132-3/86-0	770-001S704W1
202K132-3/86-0	770-001S704W1
202K132-3-0	770-001S704
202K132-3-01/180-0	770-002S704W2
202K132-3-01/42-0	770-002S704W2
202K132-3-01-0	770-002S704
202K132-4/180-0	770-001S304W2
202K132-4/42-0	770-001S304W2
202K132-4/86-0	770-001S304W1
202K132-4-0	770-001S304



Tyco to Glenair Part Number Cross Reference

Tyco Part Number	Glenair Part Number
202K132-4-01/42-0	770-002S304W2
202K132-4-01-0	770-002S304
202K142-100/180-0	770-001S205W2
202K142-100/86-0	770-001S205W1
202K142-100/86-0	770-001S205W1
202K142-100/86-0	770-001S205W1
202K142-100-0	770-001S205
202K142-100-01/180-0	770-002S205W2
202K142-100-01-0	770-002S205
202K142-25/225-0	770-001S105R
202K142-25/42-0	770-001S105W2
202K142-25/86-0	770-001S105W1
202K142-25/86-0	770-001S105W1
202K142-25/86-0	770-001S105W1
202K142-25-0	770-001S105
202K142-25-01/225-0	770-002S105R
202K142-25-01/42-0	770-002S105W2
202K142-25-01/86-0	770-002S105W1
202K142-25-01-0	770-002S105
202K142-3/180-0	770-001S705W2
202K142-3/42-0	770-001S705W2
202K142-3/86-0	770-001S705W1
202K142-3/86-0	770-001S705W1
202K142-3-0	770-001S705
202K142-3-01/180-0	770-002S705W2
202K142-3-01/42-0	770-002S705W2
202K142-3-01-0	770-002S705
202K142-4/180-0	770-001S305W2
202K142-4/42-0	770-001S305W2
202K142-4/86-0	770-001S305W1
202K142-4/86-0	770-001S305W1
202K142-4/86-0	770-001S305W1
202K142-4-0	770-001S305

Tyco Part Number	Glenair Part Number
202K142-4-01/42-0	770-002S305W2
202K142-4-01-0	770-002S305
202K153-100/180-0	770-001S206W2
202K153-100-0	770-001S206
202K153-100-01/180-0	770-002S206W2
202K153-100-01-0	770-002S206
202K153-25/225-0	770-001S106R
202K153-25/42-0	770-001S106W2
202K153-25/86-0	770-001S106W1
202K153-25-0	770-001S106
202K153-25-01/225-0	770-002S106R
202K153-25-01/42-0	770-002S106W2
202K153-25-01/86-0	770-002S106W1
202K153-25-01-0	770-002S106
202K153-3/180-0	770-001S706W2
202K153-3/42-0	770-001S706W2
202K153-3/86-0	770-001S706W1
202K153-3/86-0	770-001S706W1
202K153-3-0	770-001S706
202K153-3-01/180-0	770-002S706W2
202K153-3-01/42-0	770-002S706W2
202K153-3-01-0	770-002S706
202K153-4/180-0	770-001S306W2
202K153-4/86-0	770-001S306W1
202K153-4/86-0	770-001S306W1
202K153-4-0	770-001S306
202K153-4-01-0	770-002S306
202K163-100/180-0	770-001S207W2
202K163-100-0	770-001S207
202K163-100-01/180-0	770-002S207W2
202K163-100-01-0	770-002S207
202K163-25/225-0	770-001S107R
202K163-25/42-0	770-001S107W2





Tyco to Glenair Part Number Cross Reference

Tyco Part Number	Glenair Part Number
202K163-25/86-0	770-001S107W1
202K163-25-0	770-001S107
202K163-25-01/225-0	770-002S107R
202K163-25-01/42-0	770-002S107W2
202K163-25-01/86-0	770-002S107W1
202K163-25-01-0	770-002S107
202K163-3/180-0	770-001S707W2
202K163-3/42-0	770-001S707W2
202K163-3-0	770-001S707
202K163-3-01/180-0	770-002S707W2
202K163-3-01/42-0	770-002S707W2
202K163-3-01-0	770-002S707
202K163-4/180-0	770-001S307W2
202K163-4/42-0	770-001S307W2
202K163-4/86-0	770-001S307W1
202K163-4/86-0	770-001S307W1
202K163-4-0	770-001S307
202K163-4-01/42-0	770-002S307W2
202K163-4-01-0	770-002S307
202K174-100/180-0	770-001S208W2
202K174-100-0	770-001S208
202K174-100-01/180-0	770-002S208W2
202K174-100-01-0	770-002S208
202K174-25/225-0	770-001S108R
202K174-25/42-0	770-001S108W2
202K174-25/86-0	770-001S108W1
202K174-25-0	770-001S108
202K174-25-01/225-0	770-002S108R
202K174-25-01/42-0	770-002S108W2
202K174-25-01/86-0	770-002S108W1
202K174-25-01-0	770-002S108
202K174-3/180-0	770-001S708W2
202K174-3/42-0	770-001S708W2

Tyco Part Number	Glenair Part Number
202K174-3/86-0	770-001S708W1
202K174-3/86-0	770-001S708W1
202K174-3-0	770-001S708
202K174-3-01/180-0	770-002S708W2
202K174-3-01/42-0	770-002S708W2
202K174-3-01-0	770-002S708
202K174-4/180-0	770-001S308W2
202K174-4/42-0	770-001S308W2
202K174-4/86-0	770-001S308W1
202K174-4/86-0	770-001S308W1
202K174-4-0	770-001S308
202K174-4-01/180-0	770-002S308W2
202K174-4-01/42-0	770-002S308W2
202K174-4-01-0	770-002S308
202K185-25/225-0	770-001S109R
202K185-25/42-0	770-001S109W2
202K185-25/86-0	770-001S109W1
202K185-25/86-0	770-001S109W1
202K185-25-0	770-001S109
202K185-3/180-0	770-001S709W2
202K185-3/42-0	770-001S709W2
202K185-3/225-0	770-001S709R
202K185-3/86-0	770-001S709W1
202K185-3/86-0	770-001S709W1
202K185-3-0	770-001S709
202K185-4/180-0	770-001S309W2
202K185-4/42-0	770-001S309W2
202K185-4/86-0	770-001S309W1
202K185-4/86-0	770-001S309W1
202K185-4-0	770-001S309
202K232-25-0	770-016S116
202K232-25/225-0	770-016S116R



Tyco to Glenair Part Number Cross Reference

Tyco Part Number	Glenair Part Number
202K232-25/42-0	770-016S116W2
202K232-25/86-0	770-016S116W1
202K232-3/180-0	770-016S716W2
202K232-3/42-0	770-016S716W2
202K232-3/86-0	770-016S716W1
202K232-3-0	770-016S716
202K232-4-0	770-016S316
202K232-4/164-0	770-016S316W3
202K232-4/180-0	770-016S316W2
202K232-4/42-0	770-016S316W2
202K232-4/86-0	770-016S316W1
207W613-100/184-0	770-008S200W1BLK
207W623-100/184-0	770-008S201W1BLK
207W634-100/184-0	770-008S202W1BLK
207W644-100/184-0	770-008S203W1BLK
207W656-100/184-0	770-008S204W1BLK
207W667-100/184-0	770-008S205W1BLK
222A111-100/180-0	770-005A202W1
222A111-100-0	770-005A202
222A111-25/225-0	770-005A102R
222A111-25/42-0	770-005A102W2
222A111-25/86-0	770-005A102W1
222A111-25-0	770-005A102
222A111-3/42-0	770-005A702W2
222A111-3/86-0	770-005A702W1
222A111-3/86-0	770-005A702W1
222A111-3-0	770-005A702
222A111-4/42-0	770-005A302W2
222A111-4-0	770-005A302
222A121-100/180-0	770-005A203W1
222A121-100-0	770-005A203
222A121-25/225-0	770-005A103R
222A121-25/42-0	770-005A103W2

Tyco Part Number	Glenair Part Number
222A121-25/86-0	770-005A103W1
222A121-25-0	770-005A103
222A121-3/42-0	770-005A703W2
222A121-3/86-0	770-005A703W1
222A121-3/86-0	770-005A703W1
222A121-3-0	770-005A703
222A121-4/42-0	770-005A303W2
222A121-4-0	770-005A303
222A132-100/180-0	770-005A204W1
222A132-100-0	770-005A204
222A132-25/225-0	770-005A104R
222A132-25/42-0	770-005A104W2
222A132-25/86-0	770-005A104W1
222A132-25-0	770-005A104
222A132-3/42-0	770-005A704W2
222A132-3/86-0	770-005A704W1
222A132-3/86-0	770-005A704W1
222A132-3-0	770-005A704
222A132-4/42-0	770-005A304W2
222A132-4-0	770-005A304
222A142-100/180-0	770-005A205W1
222A142-100-0	770-005A205
222A142-25/225-0	770-005A105R
222A142-25/42-0	770-005A105W2
222A142-25/86-0	770-005A105W1
222A142-25-0	770-005A105
222A142-3/42-0	770-005A705W2
222A142-3/86-0	770-005A705W1
222A142-3/86-0	770-005A705W1
222A142-3-0	770-005A705
222A142-4/42-0	770-005A305W2
222A142-4-0	770-005A305
222A152-100/180-0	770-005A206W1





Tyco to Glenair Part Number Cross Reference

Tyco Part Number	Glenair Part Number
222A152-100-0	770-005A206
222A152-25/225-0	770-005A106R
222A152-25/42-0	770-005A106W2
222A152-25/86-0	770-005A106W1
222A152-25-0	770-005A106
222A152-3/42-0	770-005A706W2
222A152-3/86-0	770-005A706W1
222A152-3/86-0	770-005A706W1
222A152-3-0	770-005A706
222A152-4/42-0	770-005A306W2
222A152-4-0	770-005A306
222A163-100/180-0	770-005A207W1
222A163-100-0	770-005A207
222A163-25/225-0	770-005A107R
222A163-25/42-0	770-005A107W2
222A163-25/86-0	770-005A107W1
222A163-25-0	770-005A107
222A163-3/42-0	770-005A307W2
222A163-3/86-0	770-005A307W1
222A163-3/86-0	770-005A307W1
222A163-3-0	770-005A307
222A163-4/42-0	770-005A307W2
222A163-4-0	770-005A307
222A174-100/180-0	770-005A208W1
222A174-100-0	770-005A208
222A174-25/225-0	770-005A108R
222A174-25/42-0	770-005A108W2
222A174-25/86-0	770-005A108W1
222A174-25-0	770-005A108
222A174-3/42-0	770-005A708W2
222A174-3/86-0	770-005A708W1
222A174-3/86-0	770-005A708W1
222A174-3-0	770-005A708

Tyco Part Number	Glenair Part Number
222A174-4/42-0	770-005A308W2
222A174-4-0	770-005A308
222D121-100/180-0	770-003A203W1
222D121-100-0	770-003A203
222D121-25/42-0	770-003A103W2
222D121-25/86-0	770-003A103W1
222D121-25-0	770-003A103
222D121-3/180-0	770-003A703W2
222D121-3/42-0	770-003A703W2
222D121-3/86-0	770-003A703W1
222D121-3/86-0	770-003A703W1
222D121-3-0	770-003A703
222D121-4/42-0	770-003A303W2
222D121-4-0	770-003A303
222D132-100/180-0	770-003A204W1
222D132-100-0	770-003A204
222D132-25/225-0	770-003A104R
222D132-25/42-0	770-003A104W2
222D132-25/86-0	770-003A104W1
222D132-25-0	770-003A104
222D132-3/180-0	770-003A704W2
222D132-3/42-0	770-003A704W2
222D132-3/86-0	770-003A704W1
222D132-3/86-0	770-003A704W1
222D132-3-0	770-003A704
222D132-4/42-0	770-003A304W2
222D132-4-0	770-003A304
222D142-100/180-0	770-003A205W1
222D142-100-0	770-003A205
222D142-25/225-0	770-003A105R
222D142-25/42-0	770-003A105W2
222D142-25/86-0	770-003A105W1
222D142-25-0	770-003A105



Tyco to Glenair Part Number Cross Reference

Tyco Part Number	Glenair Part Number
222D142-3/180-0	770-003A705W2
222D142-3/42-0	770-003A705W2
222D142-3/86-0	770-003A705W1
222D142-3/86-0	770-003A705W1
222D142-3-0	770-003A705
222D142-4/42-0	770-003A305W2
222D142-4-0	770-003A305
222D152-100/180-0	770-003A206W1
222D152-100-0	770-003A206
222D152-25/42-0	770-003A106W2
222D152-25/86-0	770-003A106W1
222D152-25-0	770-003A106
222D152-3/180-0	770-003A706W2
222D152-3/42-0	770-003A706W2
222D152-3/86-0	770-003A706W1
222D152-3/86-0	770-003A706W1
222D152-3-0	770-003A706
222D152-4/42-0	770-003A306W2
222D152-4-0	770-003A306
222D163-100/180-0	770-003A207W1
222D163-100-0	770-003A207
222D163-25/225-0	770-003A107R
222D163-25/42-0	770-003A107W2
222D163-25/86-0	770-003A107W1
222D163-25-0	770-003A107
222D163-3/180-0	770-003A707W2
222D163-3/42-0	770-003A707W2
222D163-3/86-0	770-003A707W1
222D163-3/86-0	770-003A707W1
222D163-3-0	770-003A707
222D163-4/42-0	770-003A307W2
222D163-4-0	770-003A307
222D174-100/180-0	770-003A208W1

Tyco Part Number	Glenair Part Number
222D174-100-0	770-003A208
222D174-25/225-0	770-003A108R
222D174-25/42-0	770-003A108W2
222D174-25/86-0	770-003A108W1
222D174-25-0	770-003A108
222D174-3/180-0	770-003A708W2
222D174-3/42-0	770-003A708W2
222D174-3/86-0	770-003A708W1
222D174-3/86-0	770-003A708W1
222D174-3-0	770-003A708
222D174-4/42-0	770-003A308W2
222D174-4-0	770-003A308
222D185-100/180-0	770-003A209W1
222D185-100-0	770-003A209
222D185-25/225-0	770-003A109R
222D185-25/42-0	770-003A109W2
222D185-25/86-0	770-003A109W1
222D185-25-0	770-003A109
222D185-3/180-0	770-003A709W2
222D185-3/42-0	770-003A709W2
222D185-3/86-0	770-003A709W1
222D185-3-0	770-003A709
222D185-4/42-0	770-003A309W2
222D185-4-0	770-003A309
222D211-100/180-0	770-006A202W1
222D211-100-0	770-006A202
222D211-25/225-0	770-006A102R
222D211-25/42-0	770-006A102W2
222D211-25/86-0	770-006A102W1
222D211-25-0	770-006A102
222D211-3/180-0	770-006A702W2
222D211-3/42-0	770-006A702W2
222D211-3/86-0	770-006A702W1





Tyco to Glenair Part Number Cross Reference

Tyco Part Number	Glenair Part Number
222D211-3/86-0	770-006A702W1
222D211-3-0	770-006A702
222D211-4/42-0	770-006A302W2
222D211-4-0	770-006A302
222D221-100/180-0	770-006A203W1
222D221-100-0	770-006A203
222D221-25/225-0	770-006A103R
222D221-25/42-0	770-006A103W2
222D221-25/86-0	770-006A103W1
222D221-25-0	770-006A103
222D221-3/180-0	770-006A703W2
222D221-3/42-0	770-006A703W2
222D221-3/86-0	770-006A703W1
222D221-3/86-0	770-006A703W1
222D221-3-0	770-006A703
222D221-4/42-0	770-006A303W2
222D221-4-0	770-006A303
222D232-25/225-0	770-006A104R
222D232-25/42-0	770-006A104W2
222D232-25/86-0	770-006A104W1
222D232-25-0	770-006A104
222D232-3/180-0	770-006A704W2
222D232-3/42-0	770-006A704W2
222D232-3/86-0	770-006A704W1
222D232-3/86-0	770-006A704W1
222D232-3-0	770-006A704
222D232-4/42-0	770-006A304W2
222D232-4-0	770-006A304
222D242-25/225-0	770-006A105R
222D242-25/42-0	770-006A105W2
222D242-25/86-0	770-006A105W1
222D242-25-0	770-006A105
222D242-3/180-0	770-006A705W2

Tyco Part Number	Glenair Part Number
222D242-3/42-0	770-006A705W2
222D242-3/86-0	770-006A705W1
222D242-3/86-0	770-006A705W1
222D242-3-0	770-006A705
222D242-4/42-0	770-006A305W2
222D242-4-0	770-006A305
222D253-25/225-0	770-006A106R
222D253-25/42-0	770-006A106W2
222D253-25/86-0	770-006A106W1
222D253-25-0	770-006A106
222D253-3/180-0	770-006A706W2
222D253-3/42-0	770-006A706W2
222D253-3/86-0	770-006A706W1
222D253-3/86-0	770-006A706W1
222D253-3-0	770-006A706
222D253-4/42-0	770-006A306W2
222D253-4-0	770-006A306
222D263-25/225-0	770-006A107R
222D263-25/42-0	770-006A107W2
222D263-25/86-0	770-006A107W1
222D263-25-0	770-006A107
222D263-3/180-0	770-006A707W2
222D263-3/42-0	770-006A707W2
222D263-3/86-0	770-006A707W1
222D263-3/86-0	770-006A707W1
222D263-3-0	770-006A707
222D263-4/42-0	770-006A307W2
222D263-4-0	770-006A307
222D274-25/225-0	770-006A108R
222D274-25/42-0	770-006A108W2
222D274-25/86-0	770-006A108W1
222D274-25-0	770-006A108
222D274-3/180-0	770-006A708W2



Tyco to Glenair Part Number Cross Reference

Tyco Part Number	Glenair Part Number
222D274-3/42-0	770-006A708W2
222D274-3/86-0	770-006A708W1
222D274-3/86-0	770-006A708W1
222D274-3-0	770-006A708
222D274-4/42-0	770-006A308W2
222D274-4-0	770-006A308
222D285-25/225-0	770-006A109R
222D285-25/42-0	770-006A109W2
222D285-25/86-0	770-006A109W1
222D285-25-0	770-006A109
222D285-3/180-0	770-006A709W2
222D285-3/42-0	770-006A709W2
222D285-3/86-0	770-006A709W1
222D285-3-0	770-006A709
222D285-4/42-0	770-006A309W2
222D285-4-0	770-006A309
222D921-100/180-0	770-007A203W1
222D921-100-0	770-007A203
222D921-25/225-0	770-007A103R
222D921-25/42-0	770-007A103W2
222D921-25/86-0	770-007A103W1
222D921-25-0	770-007A103
222D921-3/42-0	770-007A703W2
222D921-3/86-0	770-007A703W1
222D921-3/86-0	770-007A703W1
222D921-3-0	770-007A703
222D921-4/42-0	770-007A303W2
222D921-4-0	770-007A303
222D932-100/180-0	770-007A204W1
222D932-100-0	770-007A204
222D932-25/225-0	770-007A104R
222D932-25/42-0	770-007A104W2
222D932-25/86-0	770-007A104W1

Tyco Part Number	Glenair Part Number
222D932-25-0	770-007A104
222D932-3/42-0	770-007A704W2
222D932-3/86-0	770-007A704W1
222D932-3/86-0	770-007A704W1
222D932-3-0	770-007A704
222D932-4/42-0	770-007A304W2
222D932-4-0	770-007A304
222D953-100/180-0	770-007A206W1
222D953-100-0	770-007A206
222D953-25/225-0	770-007A106R
222D953-25/42-0	770-007A106W2
222D953-25/86-0	770-007A106W1
222D953-25-0	770-007A106
222D953-3/42-0	770-007A706W2
222D953-3/86-0	770-007A706W1
222D953-3/86-0	770-007A706W1
222D953-3-0	770-007A706
222D953-4/42-0	770-007A306W2
222D953-4-0	770-007A306
222D963-100/180-0	770-007A207W1
222D963-100-0	770-007A207
222D963-25/225-0	770-007A107R
222D963-25/42-0	770-007A107W2
222D963-25/86-0	770-007A107W1
222D963-25-0	770-007A107
222D963-3/42-0	770-007A707W2
222D963-3/86-0	770-007A707W1
222D963-3/86-0	770-007A707W1
222D963-3-0	770-007A707
222D963-4/42-0	770-007A307W2
222D963-4-0	770-007A307
222F211-50-0	770-021A502
222F211-51/164-0	770-021A602W3





Tyco to Glenair Part Number Cross Reference

Tyco Part Number	Glenair Part Number
222F211-51-0	770-021A602
222F211-71/180-0	770-021A702W2
222F211-71/42-0	770-021A702W2
222F211-71/86-0	770-021A702W1
222F211-71-0	770-021A702
222F221-50-0	770-021A503
222F221-51/164-0	770-021A603W3
222F221-51-0	770-021A603
222F221-71/180-0	770-021A703W2
222F221-71/42-0	770-021A703W2
222F221-71/86-0	770-021A703W1
222F221-71-0	770-021A703
222F232-50-0	770-021A504
222F232-51/164-0	770-021A604W3
222F232-51-0	770-021A604
222F232-71/180-0	770-021A704W2
222F232-71/42-0	770-021A704W2
222F232-71/86-0	770-021A704W1
222F232-71-0	770-021A704
222F242-50-0	770-021A505
222F242-51/164-0	770-021A605W3
222F242-51-0	770-021A605
222F242-71/180-0	770-021A705W2
222F242-71/42-0	770-021A705W2
222F242-71/86-0	770-021A705W1
222F242-71-0	770-021A705
222F253-50-0	770-021A506
222F253-51/164-0	770-021A606W3
222F253-51-0	770-021A606
222F253-71/180-0	770-021A706W2
222F253-71/42-0	770-021A706W2
222F253-71/86-0	770-021A706W1
222F253-71-0	770-021A706

Tyco Part Number	Glenair Part Number
222F263-50-0	770-021A507
222F263-51/164-0	770-021A607W3
222F263-51-0	770-021A607
222F263-71/180-0	770-021A707W2
222F263-71/42-0	770-021A707W2
222F263-71/86-0	770-021A707W1
222F263-71-0	770-021A707
222F274-50-0	770-021A508
222F274-51/164-0	770-021A608W3
222F274-51-0	770-021A608
222F274-71/180-0	770-021A708W2
222F274-71/42-0	770-021A708W2
222F274-71/86-0	770-021A708W1
222F274-71-0	770-021A708
222F285-50-0	770-021A509
222F285-51/164-0	770-021A609W3
222F285-51-0	770-021A609
222F285-71/180-0	770-021A709W2
222F285-71/42-0	770-021A709W2
222F285-71/86-0	770-021A709W1
222F285-71-0	770-021A709
222K121-100/180-0	770-001A203W2
222K122-100/86-0	770-001A203W1
222K122-100/86-0	770-001A203W1
222K121-100-0	770-001A203
222K121-25/225-0	770-001A103R
222K121-25/42-0	770-001A103W2
222K121-25/86-0	770-001A103W1
222K121-25/86-0	770-001A103W1
222K121-25-0	770-001A103
222K121-3/180-0	770-001A703W2
222K121-3/42-0	770-001A703W2
222K121-3/86-0	770-001A703W1



Tyco to Glenair Part Number Cross Reference

Tyco Part Number	Glenair Part Number
222K121-3/86-0	770-001A703W1
222K121-3-0	770-001A703
222K121-4/42-0	770-001A303W2
222K121-4-0	770-001A303
222K132-100/180-0	770-001A204W2
222K132-100-0	770-001A204
222K132-25/225-0	770-001A104R
222K132-25/42-0	770-001A104W2
222K132-25/86-0	770-001A104W1
222K132-25/86-0	770-001A104W1
222K132-25-0	770-001A104
222K132-3/180-0	770-001A704W2
222K132-3/42-0	770-001A704W2
222K132-3/86-0	770-001A704W1
222K132-3/86-0	770-001A704W1
222K132-3-0	770-001A704
222K132-4/42-0	770-001A304W2
222K132-4-0	770-001A304
222K142-100/180-0	770-001A205W2
222K142-100-0	770-001A205
222K142-25/225-0	770-001A105R
222K142-25/42-0	770-001A105W2
222K142-25/86-0	770-001A105W1
222K142-25/86-0	770-001A105W1
222K142-25-0	770-001A105
222K142-3/180-0	770-001A705W2
222K142-3/42-0	770-001A705W2
222K142-3/86-0	770-001A705W1
222K142-3/86-0	770-001A705W1
222K142-3-0	770-001A705
222K142-4/42-0	770-001A305W2
222K142-4-0	770-001A305
222K152-100/180-0	770-001A206W2

Tyco Part Number	Glenair Part Number
222K152-100-0	770-001A206
222K152-25/225-0	770-001A106R
222K152-25/42-0	770-001A106W2
222K152-25/86-0	770-001A106W1
222K152-25/86-0	770-001A106W1
222K152-25-0	770-001A106
222K152-3/180-0	770-001A706W2
222K152-3/42-0	770-001A706W2
222K152-3/86-0	770-001A706W1
222K152-3/86-0	770-001A706W1
222K152-3-0	770-001A706
222K152-4/42-0	770-001A306W2
222K152-4-0	770-001A306
222K163-100/180-0	770-001A207W2
222K163-100-0	770-001A207
222K163-25/225-0	770-001A107R
222K163-25/42-0	770-001A107W2
222K163-25/86-0	770-001A107W1
222K163-25/86-0	770-001A107W1
222K163-25-0	770-001A107
222K163-3/180-0	770-001A707W2
222K163-3/42-0	770-001A707W2
222K163-3/86-0	770-001A707W1
222K163-3/86-0	770-001A707W1
222K163-3-0	770-001A707
222K163-4/42-0	770-001A307W2
222K163-4-0	770-001A307
222K174-100/180-0	770-001A208W2
222K174-100-0	770-001A208
222K174-25/225-0	770-001A108R
222K174-25/42-0	770-001A108W2
222K174-25/86-0	770-001A108W1
222K174-25/86-0	770-001A108W1





Tyco to Glenair Part Number Cross Reference

Tyco Part Number	Glenair Part Number
222K174-25-0	770-001A108
222K174-3/180-0	770-001A708W2
222K174-3/42-0	770-001A708W2
222K174-3/86-0	770-001A708W1
222K174-3/86-0	770-001A708W1
222K174-3-0	770-001A708
222K174-4/42-0	770-001A308W2
222K174-4-0	770-001A308
222K185-25/225-0	770-001A109R
222K185-25/42-0	770-001A109W2
222K185-25/86-0	770-001A109W1
222K185-25/86-0	770-001A109W1
222K185-25-0	770-001A109
222K185-3/180-0	770-001A709W2
222K185-3/42-0	770-001A709W2
222K185-3/86-0	770-001A709W1
222K185-3/86-0	770-001A709W1
222K185-3-0	770-001A709
222K185-4/180-0	770-001A309W2
222K185-4/42-0	770-001A309W2
222K185-4/86-0	770-001A309W1
222K185-4/86-0	770-001A309W1
222K185-4-0	770-001A309
224W142-25/225-0	770-033A105R
224W142-25/225-G43-0	770-033A105R-DH
224W142-25/225-G44-0	770-033A105R-DHS
224W142-25/86-0	770-033A105W1
224W142-25/86-G43-0	770-033A105W1-DH
224W142-25/86-G44-0	770-033A105W1-DHS
224W142-25-0	770-033A105
224W142-25-G43-0	770-033A105-DH
224W142-25-G44-0	770-033A105-DHS
224W142-3/42-0	770-033A705W2

Tyco Part Number	Glenair Part Number
224W142-3/42-G43-0	770-033A705W2-DH
224W142-3/42-G44-0	770-033A705W2-DHS
224W142-3/86-0	770-033A705W1
224W142-3/86-G43-0	770-033A705W1-DH
224W142-3/86-G44-0	770-033A705W1-DHS
224W142-3-0	770-033A705
224W142-3-G43-0	770-033A705-DH
224W142-3-G44-0	770-033A705-DHS
224W142-4/42-0	770-033A305W2
224W142-4/42-G43-0	770-033A305W2-DH
224W142-4/42-G44-0	770-033A305W2-DHS
224W142-4/86-0	770-033A305W1
224W142-4/86-G43-0	770-033A305W1-DH
224W142-4/86-G44-0	770-033A305W1-DHS
224W142-4-0	770-033A305
224W142-4-G43-0	770-033A305-DH
224W142-4-G44-0	770-033A305-DHS
242W042-25/225-0	770-033B105R
242W042-25/225-G43-0	770-033B105R-DH
242W042-25/86-0	770-033B105W1
242W042-25/86-G43-0	770-033B105W1-DH
242W042-25-0	770-033B105
242W042-25-G43-0	770-033B105-DH
242W042-3/42-0	770-033B705W2
242W042-3/42-G43-0	770-033B705W2-DH
242W042-3/86-0	770-033B705W1
242W042-3/86-G43-0	770-033B705W1-DH
242W042-3-0	770-033B705
242W042-3-G43-0	770-033B705-DH
242W042-4/42-0	770-033B305W2
242W042-4/42-G43-0	770-033B305W2-DH
242W042-4/86-0	770-033B305W1
242W042-4/86-G43-0	770-033B305W1-DH



Tyco to Glenair Part Number Cross Reference

Tyco Part Number	Glenair Part Number
242W042-4-0	770-033B305
242W042-4-G43-0	770-033B305-DH
242W053-25/225-0	770-033B106R
242W053-25/225-G43-0	770-033B106R-DH
242W053-25/86-0	770-033B106W1
242W053-25/86-G43-0	770-033B106W1-DH
242W053-25-0	770-033B106
242W053-25-G43-0	770-033B106-DH
242W053-3/42-0	770-033B706W2
242W053-3/42-G43-0	770-033B706W2-DH
242W053-3/86-0	770-033B706W1
242W053-3/86-G43-0	770-033B706W1-DH
242W053-3-0	770-033B706
242W053-3-G43-0	770-033B706-DH
242W053-4/42-0	770-033B306W2
242W053-4/42-G43-0	770-033B306W2-DH
242W053-4/86-0	770-033B306W1
242W053-4/86-G43-0	770-033B306W1-DH
242W053-4-0	770-033B306
242W053-4-G43-0	770-033B306-DH
242W063-25/225-0	770-033B107R
242W063-25/225-G43-0	770-033B107R-DH
242W063-25/86-0	770-033B107W1
242W063-25/86-G43-0	770-033B107W1-DH
242W063-25-0	770-033B107
242W063-25-G43-0	770-033B107-DH
242W063-3/42-0	770-033B707W2
242W063-3/42-G43-0	770-033B707W2-DH
242W063-3/86-0	770-033B707W1
242W063-3/86-G43-0	770-033B707W1-DH
242W063-3-0	770-033B707
242W063-3-G43-0	770-033B707-DH
242W063-4/42-0	770-033B307W2

Tyco Part Number	Glenair Part Number
242W063-4/42-G43-0	770-033B307W2-DH
242W063-4/86-0	770-033B307W1
242W063-4/86-G43-0	770-033B307W1-DH
242W063-4-0	770-033B307
242W063-4-G43-0	770-033B307-DH
263W042-25/225-0	770-034108R
263W042-25/225-G43-0	770-034108R-DH
263W042-25/225-G44-0	770-034108R-DHS
263W042-25/86-0	770-034108W1
263W042-25/86-G43-0	770-034108W1-DH
263W042-25/86-G44-0	770-034108W1-DHS
263W042-25-0	770-034108
263W042-25-G43-0	770-034108-DH
263W042-25-G44-0	770-034108-DHS
263W042-3/42-0	770-034708W2
263W042-3/42-G43-0	770-034708W2-DH
263W042-3/42-G44-0	770-034708W2-DHS
263W042-3/86-0	770-034708W1
263W042-3/86-G43-0	770-034708W1-DH
263W042-3/86-G44-0	770-034708W1-DHS
263W042-3-0	770-034708
263W042-3-G43-0	770-034708-DH
263W042-3-G44-0	770-034708-DHS
263W042-4/42-0	770-034308W2
263W042-4/42-G43-0	770-034308W2-DH
263W042-4/42-G44-0	770-034308W2-DHS
263W042-4/86-0	770-034308W1
263W042-4/86-G43-0	770-034308W1-DH
263W042-4/86-G44-0	770-034308W1-DHS
263W042-4-0	770-034308
263W042-4-G43-0	770-034308-DH
263W042-4-G44-0	770-034308-DHS
301A011-100/180-0	770-011T201W2





Tyco to Glenair Part Number Cross Reference

Tyco Part Number	Glenair Part Number
301A011-100/86-0	770-011T201W1
301A011-100-0	770-011T201
301A011-25/225-0	770-011T101R
301A011-25/42-0	770-011T101W2
301A011-25/86-0	770-011T101W1
301A011-25-0	770-011T101
301A011-3/180-0	770-011T701W2
301A011-3/42-0	770-011T701W2
301A011-3/86-0	770-011T701W1
301A011-3-0	770-011T701
301A011-4/180-0	770-011T301W2
301A011-4/42-0	770-011T301W2
301A011-4/86-0	770-011T301W1
301A011-4-0	770-011T301
301A022-100/180-0	770-011T202W2
301A022-100/86-0	770-011T202W1
301A022-100-0	770-011T202
301A022-25/225-0	770-011T102R
301A022-25/42-0	770-011T102W2
301A022-25/86-0	770-011T102W1
301A022-25-0	770-011T102
301A022-3/180-0	770-011T702W2
301A022-3/42-0	770-011T702W2
301A022-3/86-0	770-011T702W1
301A022-3-0	770-011T702
301A022-4/180-0	770-011T302W2
301A022-4/42-0	770-011T302W2
301A022-4/86-0	770-011T302W1
301A022-4-0	770-011T302
301A034-100/180-0	770-011T103W2
301A034-100/42-0	770-011T203W2
301A034-100/86-0	770-011T103W1
301A034-100-0	770-011T103

Tyco Part Number	Glenair Part Number
301A034-25/225-0	770-011T103R
301A034-25/42-0	770-011T103W2
301A034-25/86-0	770-011T103W1
301A034-25-0	770-011T103
301A034-3/180-0	770-011T703W2
301A034-3/42-0	770-011T703W2
301A034-3/86-0	770-011T703W1
301A034-3-0	770-011T703
301A034-4/180-0	770-011T303W2
301A034-4/42-0	770-011T303W2
301A034-4/86-0	770-011T303W1
301A034-4-0	770-011T303
301A048-100/180-0	770-011T204W2
301A048-100/86-0	770-011T204W1
301A048-100-0	770-011T204
301A048-25/225-0	770-011T104R
301A048-25/42-0	770-011T104W2
301A048-25/86-0	770-011T104W1
301A048-25-0	770-011T104
301A048-3/180-0	770-011T704W2
301A048-3/42-0	770-011T704W2
301A048-3/86-0	770-011T704W1
301A048-3-0	770-011T704
301A048-4/180-0	770-011T304W2
301A048-4/42-0	770-011T304W2
301A048-4/86-0	770-011T304W1
301A048-4-0	770-011T304
301A511-50-0	770-012T501
301A511-51/164-0	770-012T601W3
301A511-51/86-0	770-012T601W1
301A511-51-0	770-012T601
301A511-71/42-0	770-012T701W2
301A511-71/86-0	770-012T701W1



Tyco to Glenair Part Number Cross Reference

Tyco Part Number	Glenair Part Number
301A511-71-0	770-012T701
301A512-50-0	770-012T502
301A512-51/164-0	770-012T602W3
301A512-51/86-0	770-012T602W1
301A512-51-0	770-012T602
301A512-71/42-0	770-012T702W2
301A512-71/86-0	770-012T702W1
301A512-71-0	770-012T702
301A513-50-0	770-012T503
301A513-51/164-0	770-012T603W3
301A513-51/86-0	770-012T603W1
301A513-51-0	770-012T603
301A513-71/42-0	770-012T703W2
301A513-71/86-0	770-012T703W1
301A513-71-0	770-012T703
301A514-50-0	770-012T504
301A514-51/164-0	770-012T604W3
301A514-51-0	770-012T604
301A514-71/164-0	770-012T704W3
301A514-71/42-0	770-012T704W2
301A514-71/86-0	770-012T704W1
301A514-71-0	770-012T704
322C512-50-0	770-012T512
322C512-51/164-0	770-012T612W3
322C512-51/86-0	770-012T612W1
322C512-51-0	770-012T612
322C512-71-0	770-012T712
342A012-3-0	770-037T710
342A012-3/42-0	770-037T710W2
342A012-3/86-0	770-037T710W1
342A012-3/86-0	770-037T710W1
342A012-4-0	770-037T310
342A012-4/42-0	770-037T310W2

Tyco Part Number	Glenair Part Number
342A012-4/86-0	770-037T310W1
342A012-4/86-0	770-037T310W1
342A012-25-0	770-037T110
342A012-25/86-0	770-037T110W1
342A012-25/86-0	770-037T110W1
342A012-25/225-0	770-037T110R
342A012-50-0	770-037T510
342A012-50/164-0	770-037T510W3
342A012-50/86-0	770-037T510W1
342A012-51-0	770-037T610
342A012-51/164-0	770-037T610W3
342A012-51/86-0	770-037T610W1
342A012-71-0	770-037T710
342A012-71/42-0	770-037T710W2
342A012-71/86-0	770-037T710W1
342A012-71/86-0	770-037T710W1
342A012-100-0	770-037T210
342A012-100/42-0	770-037T210W2
342A012-100/86-0	770-037T210W1
342A012-100/86-0	770-037T210W1
342A024-3-0	770-037T711
342A024-3/42-0	770-037T711W2
342A024-3/86-0	770-037T711W1
342A024-3/86-0	770-037T711W1
342A024-4-0	770-037T311
342A024-4/42-0	770-037T311W2
342A024-4/86-0	770-037T311W1
342A024-4/86-0	770-037T311W1
342A024-25-0	770-037T111
342A024-25/86-0	770-037T111W1
342A024-25/86-0	770-037T111W1
342A024-25/225-0	770-037T111R
342A024-50-0	770-037T511





Tyco to Glenair Part Number Cross Reference

Tyco Part Number	Glenair Part Number
342A024-50/164-0	770-037T511W3
342A024-50/86-0	770-037T511W1
342A024-51-0	770-037T611
342A024-51/164-0	770-037T611W3
342A024-51/86-0	770-037T611W1
342A024-71-0	770-037T711
342A024-71/42-0	770-037T711W2
342A024-71/86-0	770-037T711W1
342A024-71/86-0	770-037T711W1
342A024-100-0	770-037T211
342A024-100/42-0	770-037T211W2
342A024-100/86-0	770-037T211W1
342A024-100/86-0	770-037T211W1
342A034-3-0	770-037T712
342A034-3/42-0	770-037T712W2
342A034-3/86-0	770-037T712W1
342A034-3/86-0	770-037T712W1
342A034-4-0	770-037T312
342A034-4/42-0	770-037T312W2
342A034-4/86-0	770-037T312W1
342A034-4/86-0	770-037T312W1
342A034-25-0	770-037T121
342A034-25/86-0	770-037T121W1
342A034-25/86-0	770-037T121W1
342A034-25/225-0	770-037T121R
342A034-50-0	770-037T512
342A034-50/164-0	770-037T512W3
342A034-50/86-0	770-037T512W1
342A034-51-0	770-037T612
342A034-51/164-0	770-037T612W3
342A034-51/86-0	770-037T612W1
342A034-71-0	770-037T712
342A034-71/42-0	770-037T712W2

Tyco Part Number	Glenair Part Number
342A034-71/86-0	770-037T712W1
342A034-71/86-0	770-037T712W1
342A034-100-0	770-037T212
342A034-100/42-0	770-037T212W2
342A034-100/86-0	770-037T212W1
342A034-100/86-0	770-037T212W1
342A048-3-0	770-037T713
342A048-3/42-0	770-037T713W2
342A048-3/86-0	770-037T713W1
342A048-4-0	770-037T313
342A048-4/42-0	770-037T313W2
342A048-4/86-0	770-037T313W1
342A048-25-0	770-037T131
342A048-25/86-0	770-037T131W1
342A048-25/225-0	770-037T131R
342A048-50-0	770-037T513
342A048-50/164-0	770-037T513W3
342A048-50/86-0	770-037T513W1
342A048-51-0	770-037T613
342A048-51/164-0	770-037T613W3
342A048-51/86-0	770-037T613W1
342A048-71-0	770-037T713
342A048-71/42-0	770-037T713W2
342A048-71/86-0	770-037T713W1
342A048-100-0	770-037T213
342A048-100/42-0	770-037T213W2
342A048-100/86-0	770-037T213W1
342A058-3-0	770-037T714
342A058-3/42-0	770-037T714W2
342A058-3/86-0	770-037T714W1
342A058-4-0	770-037T314
342A058-4/42-0	770-037T314W2
342A058-4/86-0	770-037T314W1



Tyco to Glenair Part Number Cross Reference

Tyco Part Number	Glenair Part Number
342A058-25-0	770-037T141
342A058-25/86-0	770-037T141W1
342A058-25/225-0	770-037T141R
342A058-50-0	770-037T514
342A058-50/164-0	770-037T514W3
342A058-50/86-0	770-037T514W1
342A058-51-0	770-037T614
342A058-51/164-0	770-037T614W3
342A058-51/86-0	770-037T614W1
342A058-71-0	770-037T714
342A058-71/42-0	770-037T714W2
342A058-71/86-0	770-037T714W1
342A058-100-0	770-037T214
342A058-100/42-0	770-037T214W2
342A058-100/86-0	770-037T214W1
342A112-3-0	770-035T701
342A112-3/42-0	770-035T701W2
342A112-3/86-0	770-035T701W1
342A112-4	770-035T301
342A112-4/42-0	770-035T301W2
342A112-4/86-0	770-035T301W1
342A112-25-0	770-035T101
342A112-25/86-0	770-035T101W1
342A112-25/225-0	770-035T101R
342A112-100-0	770-035T201
342A112-100/180-0	770-035T201W2
342A112-100/86-0	770-035T201W1
342A124-3	770-035T702
342A124-3/42-0	770-035T702W2
342A124-3/86-0	770-035T702W1
342A124-4	770-035T302
342A124-4/42-0	770-035T302W2
342A124-4/86-0	770-035T302W1

Tyco Part Number	Glenair Part Number
342A124-25-0	770-035T102
342A124-25/86-0	770-035T102W1
342A124-25/225-0	770-035T102R
342A124-100	770-035T202
342A124-100/180-0	770-035T202W2
342A124-100/86-0	770-035T202W1
342A138-3-0	770-035T703
342A138-3/42-0	770-035T703W2
342A138-3/86-0	770-035T703W1
342A138-4-0	770-035T303
342A138-4/42-0	770-035T303W2
342A138-4/86-0	770-035T303W1
342A138-25-0	770-035T103
342A138-25/86-0	770-035T103W1
342A138-25/225-0	770-035T103R
342A138-100-0	770-035T203
342A138-100/180-0	770-035T203W2
342A138-100/86-0	770-035T203W1
362A014-3-0	770-036T701
362A014-3/42-0	770-036T701W2
362A014-3/86-0	770-036T701W1
362A014-4-0	770-036T301
362A014-4/42-0	770-036T301W2
362A014-4/86-0	770-036T301W1
362A014-25-0	770-036T101
362A014-25/42-0	770-036T101W2
362A014-25/86-0	770-036T101W1
362A014-25/225-0	770-036T101R
362A014-100-0	770-036T201
362A014-100/180-0	770-036T201W2
362A014-100/86-0	770-036T201W1
362A024-3-0	770-036T702
362A024-3/42-0	770-036T702W2





Tyco to Glenair Part Number Cross Reference

Tyco Part Number	Glenair Part Number
362A024-3/86-0	770-036T702W1
362A024-4-0	770-036T302
362A024-4/42-0	770-036T302W2
362A024-4/86-0	770-036T302W1
362A024-25-0	770-036T102
362A024-25/42-0	770-036T102W2
362A024-25/86-0	770-036T102W1
362A024-25/225-0	770-036T102R
362A024-100-0	770-036T202
362A024-100/180-0	770-036T202W2
362A024-100/86-0	770-036T202W1
362A114-3-0	770-036T703
362A114-3/42-0	770-036T703W2
362A114-3/86-0	770-036T703W1
362A114-4-0	770-036T303
362A114-4/42-0	770-036T303W2
362A114-4/86-0	770-036T303W1
362A114-25-0	770-036T103
362A114-25/42-0	770-036T103W2
362A114-25/86-0	770-036T103W1
362A114-25/225-0	770-036T103R
362A114-100-0	770-036T203
362A114-100/180-0	770-036T203W2
362A114-100/86-0	770-036T203W1
381A301-50-0	770-009Y505
381A301-51/164-0	770-009Y605W3
381A301-51/180-0	770-009Y605W2
381A301-51/86-0	770-009Y605W1
381A301-51-0	770-009Y605
381A301-71/180-0	770-009Y705W2
381A301-71/42-0	770-009Y705W2
381A301-71/86-0	770-009Y705W1
381A301-71-0	770-009Y705

Tyco Part Number	Glenair Part Number
381A302-50-0	770-009Y506
381A302-51/164-0	770-009Y606W3
381A302-51/180-0	770-009Y606W2
381A302-51/86-0	770-009Y606W1
381A302-51-0	770-009Y606
381A302-71/180-0	770-009Y706W2
381A302-71/42-0	770-009Y706W2
381A302-71/86-0	770-009Y706W1
381A302-71-0	770-009Y706
381A303-50-0	770-009Y507
381A303-51/164-0	770-009Y607W3
381A303-51/180-0	770-009Y607W2
381A303-51-0	770-009Y607
381A303-71/180-0	770-009Y707W2
381A303-71/42-0	770-009Y707W2
381A303-71/86-0	770-009Y707W1
381A303-71-0	770-009Y707
381A304-50-0	770-009Y508
381A304-51/164-0	770-009Y608W3
381A304-51/180-0	770-009Y608W2
381A304-51-0	770-009Y608
381A304-71/180-0	770-009Y708W2
381A304-71/42-0	770-009Y708W2
381A304-71/86-0	770-009Y708W1
381A304-71-0	770-009Y708
382A012-100/86-0	770-010Y205W1
382A012-100/86-0	770-010Y205W1
382A012-100-0	770-010Y205
382A012-25/225-0	770-010Y105R
382A012-25/42-0	770-010Y105W2
382A012-25/86-0	770-010Y105W1
382A012-25/42-0	770-010Y105W2
382A012-25-0	770-010Y105



Tyco to Glenair Part Number Cross Reference

Tyco Part Number	Glenair Part Number
382A012-3/42-0	770-010Y705W2
382A012-3/86-0	770-010Y705W1
382A012-3/86-0	770-010Y705W1
382A012-3-0	770-010Y705
382A012-4/180-0	770-010Y305W2
382A012-4/42-0	770-010Y305W2
382A012-4/86-0	770-010Y305W1
382A012-4/86-0	770-010Y305W1
382A012-4-0	770-010Y305
382A023-100/180-0	770-010Y206W2
382A023-100/86-0	770-010Y206W1
382A023-100/86-0	770-010Y206W1
382A023-100-0	770-010Y206
382A023-25/225-0	770-010Y106R
382A023-25/42-0	770-010Y106W2
382A023-25/86-0	770-010Y106W1
382A023-25/86-0	770-010Y106W1
382A023-25-0	770-010Y106
382A023-3/42-0	770-010Y706W2
382A023-3/86-0	770-010Y706W1
382A023-3/86-0	770-010Y706W1
382A023-3-0	770-010Y706
382A023-4/180-0	770-010Y306W2
382A023-4/42-0	770-010Y306W2
382A023-4/86-0	770-010Y306W1
382A023-4/86-0	770-010Y306W1
382A023-4-0	770-010Y306
382A034-100/180-0	770-010Y207W2
382A034-100/86-0	770-010Y207W1
382A034-100/86-0	770-010Y207W1
382A034-100-0	770-010Y207
382A034-25/225-0	770-010Y107R
382A034-25/42-0	770-010Y107W2

Tyco Part Number	Glenair Part Number
382A034-25/86-0	770-010Y107W1
382A034-25/86-0	770-010Y107W1
382A034-25-0	770-010Y107
382A034-3/42-0	770-010Y707W2
382A034-3/86-0	770-010Y707W1
382A034-3/86-0	770-010Y707W1
382A034-3-0	770-010Y707
382A034-4/180-0	770-010Y307W2
382A034-4/42-0	770-010Y307W2
382A034-4/86-0	770-010Y307W1
382A034-4/86-0	770-010Y307W1
382A034-4-0	770-010Y307
382A046-100/180-0	770-010Y208W2
382A046-100/86-0	770-010Y208W1
382A046-100-0	770-010Y208
382A046-25/225-0	770-010Y108R
382A046-25/42-0	770-010Y108W2
382A046-25/86-0	770-010Y108W1
382A046-25-0	770-010Y108
382A046-3/42-0	770-010Y708W2
382A046-3/86-0	770-010Y708W1
382A046-3-0	770-010Y708
382A046-4/180-0	770-010Y308W2
382A046-4/42-0	770-010Y308W2
382A046-4/86-0	770-010Y308W1
382A046-4-0	770-010Y308
382C312-50-0	770-009Y516
382C312-51/164-0	770-009Y616W3
382C312-51/42-0	770-009Y616W2
382C312-51/86-0	770-009Y616W1
382C312-51-0	770-009Y616
382C312-71/42-0	770-009Y716W2
382C312-71/86-0	770-009Y716W1





Tyco to Glenair Part Number Cross Reference

Tyco Part Number	Glenair Part Number
382C312-71-0	770-009Y716
382C322-50-0	770-009Y526
382C322-51/164-0	770-009Y626W3
382C322-51/86-0	770-009Y626W1
382C322-51-0	770-009Y626
382C322-71/42-0	770-009Y726W2
382C322-71/86-0	770-009Y726W1
382C322-71-0	770-009Y726
382C332-50-0	770-009Y536
382C332-51/164-0	770-009Y636W3
382C332-51/86-0	770-009Y636W1
382C332-51-0	770-009Y636
382C332-71/42-0	770-009Y736W2
382C332-71/86-0	770-009Y736W1
382C332-71-0	770-009Y736
462A011-100/180-0	770-013209W2
462A011-100/86-0	770-013209W1
462A011-100/86-0	770-013209W1
462A011-100-0	770-013209
462A011-25/225-0	770-013109R
462A011-25/42-0	770-013109W2
462A011-25/86-0	770-013109W1
462A011-25/86-0	770-013109W1
462A011-25-0	770-013109
462A011-3/42-0	770-013709W2
462A011-3/86-0	770-013709W1
462A011-3/86-0	770-013709W1
462A011-3-0	770-013709
462A011-4/180-0	770-013309W2
462A011-4/42-0	770-013309W2
462A011-4/86-0	770-013309W1
462A011-4/86-0	770-013309W1
462A011-4-0	770-013309

Tyco Part Number	Glenair Part Number
462A023-100/180-0	770-013210W2
462A023-100/86-0	770-013210W1
462A023-100/86-0	770-013210W1
462A023-100-0	770-013210
462A023-25/225-0	770-013110R
462A023-25/42-0	770-013110W2
462A023-25/86-0	770-013110W1
462A023-25/86-0	770-013110W1
462A023-25-0	770-013110
462A023-3/42-0	770-013710W2
462A023-3/86-0	770-013710W1
462A023-3/86-0	770-013710W1
462A023-3-0	770-013710
462A023-4/180-0	770-013310W2
462A023-4/42-0	770-013310W2
462A023-4/86-0	770-013310W1
462A023-4/86-0	770-013310W1
462A023-4-0	770-013310
462A034-100/180-0	770-013211W2
462A034-100/86-0	770-013211W1
462A034-100/86-0	770-013211W1
462A034-100-0	770-013211
462A034-25/225-0	770-013111R
462A034-25/42-0	770-013111W2
462A034-25/86-0	770-013111W1
462A034-25/86-0	770-013111W1
462A034-25-0	770-013111
462A034-3/42-0	770-013711W2
462A034-3/86-0	770-013711W1
462A034-3/86-0	770-013711W1
462A034-3-0	770-013711
462A034-4/180-0	770-013311W2
462A034-4/42-0	770-013311W2



Tyco to Glenair Part Number Cross Reference

Tyco Part Number	Glenair Part Number
462A034-4/86-0	770-013311W1
462A034-4/86-0	770-013311W1
462A034-4-0	770-013311
462A046-100/180-0	770-013212W2
462A046-100/86-0	770-013212W1
462A046-100/86-0	770-013212W1
462A046-100-0	770-013212
462A046-25/225-0	770-013112R
462A046-25/42-0	770-013112W2
462A046-25/86-0	770-013112W1
462A046-25/86-0	770-013112W1
462A046-25-0	770-013112
462A046-3/42-0	770-013712W2
462A046-3/86-0	770-013712W1
462A046-3/86-0	770-013712W1
462A046-3-0	770-013712
462A046-4/180-0	770-013312W2
462A046-4/42-0	770-013312W2
462A046-4/86-0	770-013312W1
462A046-4/86-0	770-013312W1
462A046-4-0	770-013312
462A060-100/180-0	770-013213W2
462A060-100/86-0	770-013213W1
462A060-100-0	770-013213
462A060-25/225-0	770-013113R
462A060-25/42-0	770-013113W2
462A060-25/86-0	770-013113W1
462A060-25-0	770-013113
462A060-3/42-0	770-013713W2
462A060-3/86-0	770-013713W1
462A060-3-0	770-013713
462A060-4/180-0	770-013313W2
462A060-4/42-0	770-013313W2

Tyco Part Number	Glenair Part Number
462A060-4/86-0	770-013313W1
462A060-4-0	770-013313
462A214-3	770-038T701
462A214-3/42-0	770-038T701W2
462A214-3/86-0	770-038T701W1
462A214-4	770-038T301
462A214-4/42-0	770-038T301W2
462A214-4/86-0	770-038T301W1
462A214-25	770-038T101
462A214-25/42-0	770-038T101W2
462A214-25/86-0	770-038T101W1
462A214-25/225-0	770-038T101R
462A421-50-0	770-014509
462A421-51/164-0	770-014609W3
462A421-51/86-0	770-014609W1
462A421-51-0	770-014609
462A421-71/180-0	770-014709W2
462A421-71/42-0	770-014709W2
462A421-71/86-0	770-014709W1
462A421-71-0	770-014709
462A422-50-0	770-014510
462A422-51/164-0	770-014610W3
462A422-51/86-0	770-014610W1
462A422-51-0	770-014610
462A422-71/180-0	770-014710W2
462A422-71/42-0	770-014710W2
462A422-71/86-0	770-014710W1
462A422-71-0	770-014710
462A423-50-0	770-014511
462A423-51/164-0	770-014611W3
462A423-51-0	770-014611
462A423-71/42-0	770-014711W2
462A423-71/86-0	770-014711W1





Tyco to Glenair Part Number Cross Reference

Tyco Part Number	Glenair Part Number
462A423-71-0	770-014711
562A011-100/180-0	770-015214W2
562A011-100/86-0	770-015214W1
562A011-100-0	770-015214
562A011-25/225-0	770-015114R
562A011-25/42-0	770-015114W2
562A011-25/86-0	770-015114W1
562A011-25-0	770-015114
562A011-3/42-0	770-015714W2
562A011-3/86-0	770-015714W1
562A011-3-0	770-015714
562A011-4/42-0	770-015314W2
562A011-4/86-0	770-015314W1
562A011-4-0	770-015314
562A022-100/180-0	770-015215W2
562A022-100/86-0	770-015215W1
562A022-100/86-0	770-015215W1
562A022-100-0	770-015215
562A022-25/225-0	770-015115R
562A022-25/42-0	770-015115W2
562A022-25/86-0	770-015115W1
562A022-25/86-0	770-015115W1
562A022-25-0	770-015115
562A022-3/42-0	770-015715W2
562A022-3/86-0	770-015715W1
562A022-3/86-0	770-015715W1
562A022-3-0	770-015715
562A022-4/42-0	770-015315W2
562A022-4/86-0	770-015315W1
562A022-4/86-0	770-015315W1
562A022-4-0	770-015315
562A032-100/180-0	770-015216W2
562A032-100/86-0	770-015216W1

Tyco Part Number	Glenair Part Number
562A032-100-0	770-015216
562A032-25/225-0	770-015116R
562A032-25/42-0	770-015116W2
562A032-25/86-0	770-015116W1
562A032-25-0	770-015116
562A032-3/42-0	770-015716W2
562A032-3/86-0	770-015716W1
562A032-3-0	770-015716
562A032-4/42-0	770-015316W2
562A032-4/86-0	770-015316W1
562A032-4-0	770-015316
562A043-100/180-0	770-015217W2
562A043-100/86-0	770-015217W1
562A043-100/86-0	770-015217W1
562A043-100-0	770-015217
562A043-25/225-0	770-015117R
562A043-25/42-0	770-015117W2
562A043-25/86-0	770-015117W1
562A043-25/86-0	770-015117W1
562A043-25-0	770-015117
562A043-3/42-0	770-015717W2
562A043-3/86-0	770-015717W1
562A043-3/86-0	770-015717W1
562A043-3-0	770-015717
562A043-4/42-0	770-015317W2
562A043-4/86-0	770-015317W1
562A043-4/86-0	770-015317W1
562A043-4-0	770-015317
562A054-100/180-0	770-015218W2
562A054-100/86-0	770-015218W1
562A054-100/86-0	770-015218W1
562A054-100-0	770-015218
562A054-25/225-0	770-015118R



Tyco to Glenair Part Number Cross Reference

Tyco Part Number	Glenair Part Number
562A054-25/42-0	770-015118W2
562A054-25/86-0	770-015118W1
562A054-25/86-0	770-015118W1
562A054-25-0	770-015118
562A054-3/42-0	770-015718W2
562A054-3/86-0	770-015718W1
562A054-3/86-0	770-015718W1
562A054-3-0	770-015718
562A054-4/42-0	770-015318W2
562A054-4/86-0	770-015318W1
562A054-4/86-0	770-015318W1
562A054-4-0	770-015318
562A067-100/180-0	770-015219W2
562A067-100/86-0	770-015219W1
562A067-100-0	770-015219
562A067-25/225-0	770-015119R
562A067-25/42-0	770-015119W2
562A067-25/86-0	770-015119W1
562A067-25-0	770-015119
562A067-3/42-0	770-015719W2
562A067-3/86-0	770-015719W1
562A067-3-0	770-015719
562A067-4/42-0	770-015319W2
562A067-4/86-0	770-015319W1
562A067-4-0	770-015319



Hellerman to Glenair Part Number Cross Reference

Hellermann Part Number	Glenair Part Number
104-1-H-WM250	770-005S202W2
104-1-H-W17	770-005S202W1
104-1-H	770-005S202
104-1-G-W24	770-005S102R
104-1-G-WM250	770-005S102W2
104-1-G-W17	770-005S102W1
104-1-G	770-005S102
104-1-B7-WM250	770-005S702W2
104-1-B7-W17	770-005S702W1
104-1-B7-W21	770-005S702W1
104-1-B7	770-005S702
104-1-B7-WM250	770-005S302W2
104-1-B7-WM250	770-005S302W2
104-1-B7-W17	770-005S302W1
104-1-B7-W21	770-005S302W1
104-1-B7	770-005S302
105-1-H-WM250	770-005S203W2
105-1-H-W8	770-005S203W1
105-1-H-W17	770-005S203W1
105-1-H-W21	770-005S203W1
105-1-H	770-005S203
105-1-G-W24	770-005S103R
105-1-G-WM250	770-005S103W2
105-1-G-W8	770-005S103W1
105-1-G	770-005S103
105-1-B7-WM250	770-005S703W2
105-1-B7-W17	770-005S703W1
105-1-B7-W21	770-005S703W1
105-1-B7	770-005S703
105-1-B7-WM250	770-005S303W2
105-1-B7-WM250	770-005S303W2
105-1-B7-W17	770-005S303W1

Hellermann Part Number	Glenair Part Number
105-1-B7	770-005S303
106-1-H-WM250	770-005S204W2
106-1-H-W8	770-005S204W1
106-1-H-W17	770-005S204W1
106-1-H-W21	770-005S204W1
106-1-H	770-005S204
106-1-G-W24	770-005S104R
106-1-G-WM250	770-005S104W2
106-1-G-W8	770-005S104W1
106-1-G-W17	770-005S104W1
106-1-G-W21	770-005S104W1
106-1-G	770-005S104
106-1-B7-WM250	770-005S704W2
106-1-B7-W17	770-005S704W1
106-1-B7-W21	770-005S704W1
106-1-B7	770-005S704
106-1-B7-WM250	770-005S304W2
106-1-B7-W8	770-005S304W2
106-1-B7-WM250	770-005S304W2
107-4-B7-W17	770-005S304W1
107-4-B7-W21	770-005S304W1
106-1-B7	770-005S304
101-4-H-WM250	770-005S205W2
101-4-H-W17	770-005S205W1
101-1-H	770-005S205
101-1-G-W24	770-005S105R
101-1-G-WM250	770-005S105W2
101-1-G-W8	770-005S105W1
101-1-G	770-005S105
101-1-B7-WM250	770-005S705W2
101-1-B7-WM250	770-005S705W2
101-1-B7-W17	770-005S705W1



Hellerman to Glenair Part Number Cross Reference

Hellermann Part Number	Glenair Part Number
101-1-B7-W21	770-005S705W1
101-1-B7	770-005S705
101-1-B7-WM250	770-005S305W2
101-1-B7-WM250	770-005S305W2
101-1-B7-W17	770-005S305W1
101-1-B7-W21	770-005S305W1
101-1-B7	770-005S305
102-1-H-WM250	770-005S206W2
102-1-H-WM250	770-005S206W2
102-1-H-W8	770-005S206W1
102-1-H-W17	770-005S206W1
102-1-H-W21	770-005S206W1
102-1-H	770-005S206
102-1-G-W24	770-005S106R
102-1-G-WM250	770-005S106W2
102-1-G-WM250	770-005S106W2
102-1-G-W8	770-005S106W1
102-1-G-W17	770-005S106W1
102-1-G-W21	770-005S106W1
102-1-G	770-005S106
102-1-B7-WM250	770-005S706W2
102-1-B7-WM250	770-005S706W2
102-1-B7-W17	770-005S706W1
102-1-B7-W21	770-005S706W1
102-1-B7	770-005S706
102-1-B7-WM250	770-005S306W2
102-1-B7-WM250	770-005S306W2
102-1-B7-W17	770-005S306W1
102-1-B7-W21	770-005S306W1
102-1-B7	770-005S306
103-1-H-WM250	770-005S207W2
103-1-H-W8	770-005S207W1

Hellermann Part Number	Glenair Part Number
103-1-H-W17	770-005S207W1
103-1-H-W21	770-005S207W1
103-1-H	770-005S207
103-1-G-W24	770-005S107R
103-1-G-WM250	770-005S107W2
103-1-G-W8	770-005S107W1
103-1-G-W17	770-005S107W1
103-1-G-W21	770-005S107W1
103-1-G	770-005S107
103-1-B7-WM250	770-005S707W2
103-1-B7-WM250	770-005S707W2
103-1-B7-W17	770-005S707W1
103-1-B7-W21	770-005S707W1
103-1-B7	770-005S707
103-1-B7-WM250	770-005S307W2
103-1-B7-WM250	770-005S307W2
103-1-B7-W17	770-005S307W1
103-1-W21	770-005S307W1
103-1-B7	770-005S307
107-1-H-WM250	770-005S208W2
107-1-H-W8	770-005S208W1
107-1-H-W17	770-005S208W1
107-1-H-W21	770-005S208W1
107-1-H	770-005S208
107-1-G-W24	770-005S108R
107-1-G-WM250	770-005S108W2
107-1-G-W8	770-005S108W1
107-1-G-W17	770-005S108W1
107-1-G-W21	770-005S108W1
107-1-G	770-005S108
107-1-B7-WM250	770-005S708W2
107-1-B7-W17	770-005S708W1





Hellerman to Glenair Part Number Cross Reference

Hellermann Part Number	Glenair Part Number
107-1-B7-W21	770-005S708W1
107-1-B7	770-005S708
107-1-B7-WM250	770-005S308W2
107-1-B7-WM250	770-005S308W2
107-1-B7-W17	770-005S308W1
107-1-B7-W21	770-005S308W1
107-1-B7	770-005S308
118-1-H-WM250	770-005S209W2
118-1-H-W8	770-005S209W1
118-1-H-W17	770-005S209W1
118-1-H-W21	770-005S209W1
118-1-H	770-005S209
118-1-G-W24	770-005S109R
118-1-G-WM250	770-005S109W2
118-1-G-W8	770-005S109W1
118-1-G-W17	770-005S109W1
118-1-G-W21	770-005S109W1
118-1-G	770-005S109
118-1-B7-WM250	770-005S709W2
118-1-B7-W17	770-005S709W1
118-1-B7-W21	770-005S709W1
118-1-B7	770-005S709
118-1-B7-WM250	770-005S309W2
118-1-B7-W17	770-005S309W1
118-1-B7-W21	770-005S309W1
118-1-B7	770-005S309
119-1-H-WM250	770-005S210W2
119-1-H-W8	770-005S210W1
119-1-H-W17	770-005S210W1
119-1-H-W21	770-005S210W1
119-1-H	770-005S210
119-1-G-W24	770-005S110R

Hellermann Part Number	Glenair Part Number
119-1-G-WM250	770-005S110W2
119-1-G-W8	770-005S110W1
119-1-G-W17	770-005S110W1
119-1-G-W21	770-005S110W1
119-1-G	770-005S110
119-1-B7-WM250	770-005S710W2
119-1-B7-W8	770-005S710W1
119-1-B7-W17	770-005S710W1
119-1-B7-W21	770-005S710W1
119-1-B7	770-005S710
119-1-B7-WM250	770-005S310W2
119-1-B7-W17	770-005S310W1
119-1-B7-W21	770-005S310W1
119-1-B7	770-005S310
313C722-8	770-022C501
313C722-8-W17	770-022C501W1
313C722-8-W21	770-022C501W1
	770-022C601W3
313C722-9-W17	770-022C601W1
313C722-9-W21	770-022C601W1
313C722-9	770-022C601
313C732-8	770-022C502
313C732-8-W17	770-022C502W1
313C732-8-W21	770-022C502W1
313C732-9-W17	770-022C602W1
313C732-9-W21	770-022C602W1
313C732-9	770-022C602
313C743-8	770-022C503
313C743-8-W17	770-022C503W1
313C743-8-W21	770-022C503W1
313C743-9-W17	770-022C603W1
313C743-9-W21	770-022C603W1



Hellerman to Glenair Part Number Cross Reference

Hellermann Part Number	Glenair Part Number
313C743-9	770-022C603
313C753-8	770-022C504
313C753-8-W17	770-022C504W1
313C753-8-W21	770-022C504W1
313C753-9-W17	770-022C604W1
313C753-9-W21	770-022C604W1
313C753-9	770-022C604
313C764-8	770-022C505
313C764-8-W17	770-022C505W1
313C764-8-W21	770-022C505W1
313C764-9-W17	770-022C605W1
313C764-9-W21	770-022C605W1
313C764-9	770-022C605
313C764-8-W17	770-022C506W1
313C764-8-W21	770-022C506W1
313C764-8	770-022C506
313C764-9-W17	770-022C606W1
313C764-9-W21	770-022C606W1
313C764-9	770-022C606
104-4-H-WM250	770-003S202W2
104-4-H-W8	770-003S202W1
104-4-H-W17	770-003S202W1
104-4-H-W21	770-003S202W1
104-4-H	770-003S202
104-4-G-W24	770-003S102R
104-4-G-WM250	770-003S102W2
104-4-G-WM250	770-003S102W2
104-4-G-W8	770-003S102W1
104-4-G-W17	770-003S102W1
104-4-G-W21	770-003S102W1
104-4-G	770-003S102
104-4-B7-WM250	770-003S702W2

Hellermann Part Number	Glenair Part Number
104-4-B7-WM250	770-003S702W2
104-4-B7-W17	770-003S702W1
104-4-B7-W21	770-003S702W1
104-4-B7	770-003S702
104-4-B7-WM250	770-003S302W2
104-4-B7-WM250	770-003S302W2
104-4-B7-W17	770-003S302W1
104-4-B7-W21	770-003S302W1
104-4-B7	770-003S302
105-4-H-WM250	770-003S203W2
105-4-H-W8	770-003S203W1
105-4-H-W17	770-003S203W1
105-4-H-W21	770-003S203W1
105-4-H	770-003S203
105-4-G-W24	770-003S103R
105-4-G-WM250	770-003S103W2
105-4-G-W8	770-003S103W1
105-4-G-W17	770-003S103W1
105-4-G-W21	770-003S103W1
105-4-G	770-003S103
105-4-B7-WM250	770-003S703W2
105-4-B7-WM250	770-003S703W2
105-4-B7-W17	770-003S703W1
105-4-B7-W21	770-003S703W1
105-4-B7	770-003S703
105-4-B7-WM250	770-003S303W2
105-4-B7-WM250	770-003S303W2
105-4-B7-W17	770-003S303W1
105-4-B7-W21	770-003S303W1
105-4-B7	770-003S303
106-4-H-WM250	770-003S204W2
106-4-H-W8	770-003S204W1





Hellerman to Glenair Part Number Cross Reference

Hellermann Part Number	Glenair Part Number
106-4-H-W17	770-003S204W1
106-4-H-W21	770-003S204W1
106-4-H	770-003S204
106-4-G-W24	770-003S104R
106-4-G-WM250	770-003S104W2
106-4-G-W8	770-003S104W1
106-4-G-W17	770-003S104W1
106-4-G-W21	770-003S104W1
106-4-G	770-003S104
106-4-B7-WM250	770-003S704W2
106-4-B7-WM250	770-003S704W2
106-4-B7-W17	770-003S704W1
106-4-B7-W21	770-003S704W1
106-4-B7	770-003S704
106-4-B7-WM250	770-003S304W2
106-4-B7-WM250	770-003S304W2
106-4-B7-W17	770-003S304W1
106-4-B7-W21	770-003S304W1
106-4-B7	770-003S304
101-4-H-WM250	770-003S205W2
101-4-H-W8	770-003S205W1
101-4-H-W17	770-003S205W1
101-4-H-W21	770-003S205W1
101-4-H	770-003S205
101-4-G-W24	770-003S105R
101-4-G-WM250	770-003S105W2
101-4-G-W8	770-003S105W1
101-4-G-W17	770-003S105W1
101-4-G-W21	770-003S105W1
101-4-G	770-003S105
101-4-B7-WM250	770-003S705W2
101-4-B7-WM250	770-003S705W2

Hellermann Part Number	Glenair Part Number
101-4-B7-W17	770-003S705W1
101-4-B7-W21	770-003S705W1
101-4-B7	770-003S705
101-4-B7-WM250	770-003S305W2
101-4-B7-W250	770-003S305W2
101-4-B7-W17	770-003S305W1
101-4-B7-W21	770-003S305W1
101-4-B7	770-003S305
102-4-H-WM250	770-003S206W2
102-4-H-W8	770-003S206W1
102-4-H-W17	770-003S206W1
102-4-H-W21	770-003S206W1
102-4-H	770-003S206
102-4-G-W24	770-003S106R
102-4-G-WM250	770-003S106W2
102-4-G-W8	770-003S106W1
102-4-G-W17	770-003S106W1
102-4-G-W21	770-003S106W1
102-4-G	770-003S106
102-4-B7-WM250	770-003S706W2
102-4-B7-WM250	770-003S706W2
102-4-B7-W17	770-003S706W1
102-4-B7-W21	770-003S706W1
102-4-B7	770-003S706
102-4-B7-WM250	770-003S306W2
102-4-B7-WM250	770-003S306W2
102-4-B7-W17	770-003S306W1
102-4-B7-W21	770-003S306W1
102-4-B7	770-003S306
103-4-H-WM250	770-003S207W2
103-4-H-W8	770-003S207W1
103-4-H-W17	770-003S207W1



Hellerman to Glenair Part Number Cross Reference

Hellermann Part Number	Glenair Part Number
103-4-H-W21	770-003S207W1
103-4-H	770-003S207
103-4-G-W24	770-003S107R
103-4-G-WM250	770-003S107W2
103-4-G-W8	770-003S107W1
103-4-G	770-003S107
103-4-B7-WM250	770-003S707W2
103-4-B7-WM250	770-003S707W2
103-4-B7-W17	770-003S707W1
103-4-B7-W21	770-003S707W1
103-4-B7	770-003S707
103-4-B7-WM250	770-003S307W2
103-4-B7-WM250	770-003S307W2
103-4-B7-W17	770-003S307W1
103-4-B7-W21	770-003S307W1
103-4-B7	770-003S307
107-4-H	770-003S208
107-4-H-WM250	770-003S208W2
107-4-H-W8	770-003S208W1
107-4-H-W17	770-003S208W1
107-4-H-W21	770-003S208W1
107-4-G-W24	770-003S108R
107-4-G-WM250	770-003S108W2
107-4-G-W8	770-003S108W1
107-4-G-W17	770-003S108W1
107-4-G-W21	770-003S108W1
107-4-G	770-003S108
107-4-B7-WM250	770-003S708W2
107-4-B7-WM250	770-003S708W2
107-4-B7-W17	770-003S708W1
107-4-B7-W21	770-003S708W1
107-4-B7	770-003S708

Hellermann Part Number	Glenair Part Number
107-4-B7-WM250	770-003S308W2
107-4-B7-WM250	770-003S308W2
104-4-B7-W17	770-003S308W1
104-4-B7-W21	770-003S308W1
107-4-B7	770-003S308
118-4-H-WM250	770-003S209W2
118-4-H-W8	770-003S209W1
118-4-H-W17	770-003S209W1
118-4-H-W21	770-003S209W1
118-4-H	770-003S209
118-4-G-W24	770-003S109R
118-4-G-WM250	770-003S109W2
118-4-G-W8	770-003S109W1
118-4-G-W17	770-003S109W1
118-4-G-W21	770-003S109W1
118-4-G	770-003S109
118-4-B7-WM250	770-003S709W2
118-4-B7-WM250	770-003S709W2
118-4-B7-W17	770-003S709W1
118-4-B7-W21	770-003S709W1
118-4-B7	770-003S709
118-4-B7-WM250	770-003S309W2
118-4-B7-WM250	770-003S309W2
118-4-B7-W17	770-003S309W1
118-4-B7-W21	770-003S309W1
118-4-B7	770-003S309
129-4-H-WM250	770-006S202W2
129-4-H-W8	770-006S202W1
129-4-H-W17	770-006S202W1
129-4-H-W21	770-006S202W1
129-4-H	770-006S202
129-4-G-W24	770-006S102R





Hellerman to Glenair Part Number Cross Reference

Hellermann Part Number	Glenair Part Number
129-4-G-WM250	770-006S102W2
129-4-G-W8	770-006S102W1
129-4-G-W17	770-006S102W1
129-4-G-W21	770-006S102W1
129-4-G	770-006S102
129-4-B7-WM250	770-006S702W2
129-4-B7-WM250	770-006S702W2
129-4-B7-W17	770-006S702W1
129-4-B7-W21	770-006S702W1
129-4-B7	770-006S702
129-4-J-WM250	770-006S302W2
129-4-J-WM250	770-006S302W2
129-4-J-W17	770-006S302W1
129-4-J-W21	770-006S302W1
129-4-J	770-006S302
130-4-H-WM250	770-006S203W2
130-4-H-W8	770-006S203W1
130-4-H-W17	770-006S203W1
130-4-H-W21	770-006S203W1
130-4-H	770-006S203
130-4-G-W24	770-006S103R
130-4-G-WM250	770-006S103W2
130-4-G-W8	770-006S103W1
130-4-G-W17	770-006S103W1
130-4-G-W21	770-006S103W1
130-4-G	770-006S103
130-4-B7-WM250	770-006S703W2
130-4-B7-WM250	770-006S703W2
130-4-B7-W17	770-006S703W1
130-4-B7-W21	770-006S703W1
130-4-B7	770-006S703
130-4-J-WM250	770-006S303W2

Hellermann Part Number	Glenair Part Number
130-4-J-WM250	770-006S303W2
130-4-J-W17	770-006S303W1
130-4-J-W21	770-006S303W1
130-4-J	770-006S303
131-4-H-WM250	770-006S204W2
131-4-H-W8	770-006S204W1
131-4-H-W17	770-006S204W1
131-4-H-W21	770-006S204W1
131-4-H	770-006S204
131-4-G-W24	770-006S104R
131-4-G-WM250	770-006S104W2
131-4-G-W8	770-006S104W1
131-4-G-W17	770-006S104W1
131-4-G-W21	770-006S104W1
131-4-G	770-006S104
131-4-B7-WM250	770-006S704W2
131-4-B7-WM250	770-006S704W2
131-4-B7-W17	770-006S704W1
131-4-B7-W21	770-006S704W1
131-4-B7	770-006S704
131-4-J-WM250	770-006S304W2
131-4-J-WM250	770-006S304W2
131-4-J-W17	770-006S304W1
131-4-J-W21	770-006S304W1
131-4-J	770-006S304
132-4-H-WM250	770-006S205W2
132-4-H-W8	770-006S205W1
132-4-H-W17	770-006S205W1
132-4-H-W1	770-006S205W1
132-4-H	770-006S205
132-4-G-W24	770-006S105R
132-4-G-WM250	770-006S105W2



Hellerman to Glenair Part Number Cross Reference

Hellermann Part Number	Glenair Part Number
132-4-G-W8	770-006S105W1
132-4-G-W17	770-006S105W1
132-4-G-W21	770-006S105W1
132-4-G	770-006S105
132-4-B7-WM250	770-006S705W2
132-4-B7-WM250	770-006S705W2
132-4-B7-W17	770-006S705W1
132-4-B7-W21	770-006S705W1
132-4-B7	770-006S705
132-4-J-WM250	770-006S305W2
132-4-J-WM250	770-006S305W2
132-4-J-W17	770-006S305W1
132-4-J-W21	770-006S305W1
132-4-J	770-006S305
133-4-H-WM250	770-006S206W2
133-4-H-W8	770-006S206W1
133-4-H-W17	770-006S206W1
133-4-H-W21	770-006S206W1
133-4-H	770-006S206
133-4-G-W24	770-006S106R
133-4-G-WM250	770-006S106W2
133-4-G-W8	770-006S106W1
133-4-G-W17	770-006S106W1
133-4-G-W21	770-006S106W1
133-4-G	770-006S106
133-4-B7-WM250	770-006S706W2
133-4-B7-WM250	770-006S706W2
133-4-B7-W17	770-006S706W1
133-4-B7-W21	770-006S706W1
133-4-B7	770-006S706
133-4-J-WM250	770-006S306W2
133-4-J-WM250	770-006S306W2

Hellermann Part Number	Glenair Part Number
133-4-J-W17	770-006S306W1
133-4-J-W21	770-006S306W1
133-4-J	770-006S306
134-4-H-WM250	770-006S207W2
134-4-H-W8	770-006S207W1
134-4-H-W17	770-006S207W1
134-4-H-W21	770-006S207W1
134-4-H	770-006S207
134-4-G-W24	770-006S107R
134-4-G-WM250	770-006S107W2
134-4-G-W8	770-006S107W1
134-4-G-W17	770-006S107W1
134-4-G-W21	770-006S107W1
134-4-G	770-006S107
134-4-B7-WM250	770-006S707W2
134-4-B7-WM250	770-006S707W2
134-4-B7-W17	770-006S707W1
134-4-B7-W21	770-006S707W1
134-4-B7	770-006S707
134-4-J-WM250	770-006S307W2
134-4-J-WM250	770-006S307W2
134-4-J-W17	770-006S307W1
134-4-J-W21	770-006S307W1
134-4-J	770-006S307
135-4-H-WM250	770-006S208W2
135-4-H-W8	770-006S208W1
135-4-H-W17	770-006S208W1
135-4-H-W21	770-006S208W1
135-4-H	770-006S208
135-4-G-W24	770-006S108R
135-4-G-WM250	770-006S108W2
135-4-G-W8	770-006S108W1





Hellerman to Glenair Part Number Cross Reference

Hellermann Part Number	Glenair Part Number
135-4-G-W17	770-006S108W1
135-4-G-W21	770-006S108W1
135-4-G	770-006S108
135-4-B7-WM250	770-006S708W2
135-4-B7-WM250	770-006S708W2
135-4-B7-W17	770-006S708W1
135-4-B7-W21	770-006S708W1
135-4-B7	770-006S708
135-4-J-WM250	770-006S308W2
135-4-J	770-006S308
136-4-H-WM250	770-006S209W2
136-4-H-W8	770-006S209W1
136-4-H-W17	770-006S209W1
136-4-H-W21	770-006S209W1
136-4-H	770-006S209
136-4-G-W24	770-006S109R
136-4-G-WM250	770-006S109W2
136-4-G-W8	770-006S109W1
136-4-G-W17	770-006S109W1
136-4-G-W21	770-006S109W1
136-4-G	770-006S109
136-4-B7-WM250	770-006S709W2
136-4-B7-WM250	770-006S709W2
136-4-B7-W17	770-006S709W1
136-4-B7-W21	770-006S709W1
136-4-B7	770-006S709
136-4-J-WM250	770-006S309W2
136-4-J-WM250	770-006S309W2
136-4-J-W17	770-006S309W1
136-4-J-W21	770-006S309W1
136-4-J	770-006S309
176-1-H-WM250	770-007S203W2

Hellermann Part Number	Glenair Part Number
176-1-H-W8	770-007S203W1
176-1-H-W17	770-007S203W1
176-1-H-W21	770-007S203W1
176-1-H	770-007S203
176-1-G-W24	770-007S103R
176-1-G-WM250	770-007S103W2
176-1-G-W8	770-007S103W1
176-1-G-W17	770-007S103W1
176-1-G-W21	770-007S103W1
176-1-G	770-007S103
176-1-B7-WM250	770-007S703W2
176-1-B7-WM250	770-007S703W2
176-1-B7-W17	770-007S703W1
176-1-B7-W21	770-007S703W1
176-1-B7	770-007S703
176-1-J-WM250	770-007S303W2
176-1-J-WM250	770-007S303W2
176-1-J-W17	770-007S303W1
176-1-J-W21	770-007S303W1
176-1-J	770-007S303
177-1-H-WM250	770-007S204W2
177-1-H-W8	770-007S204W1
177-1-H-W17	770-007S204W1
177-1-H-W21	770-007S204W1
177-1-H	770-007S204
177-1-G-W24	770-007S104R
177-1-G-WM250	770-007S104W2
177-1-G-W8	770-007S104W1
177-1-G-W17	770-007S104W1
177-1-G-W21	770-007S104W1
177-1-G	770-007S104
177-1-B7-WM250	770-007S704W2



Hellerman to Glenair Part Number Cross Reference

Hellermann Part Number	Glenair Part Number
177-1-B7-WM250	770-007S704W2
177-1-B7-W17	770-007S704W1
177-1-B7-W21	770-007S704W1
177-1-B7	770-007S704
177-1-J-WM250	770-007S304W2
177-1-J-WM250	770-007S304W2
177-1-J-WM250	770-007S304W1
177-1-J-W17	770-007S304W1
177-1-J-W21	770-007S304W1
177-1-J	770-007S304
178-1-H-WM250	770-007S206W2
178-1-H-W8	770-007S206W1
178-1-H-W17	770-007S206W1
178-1-H-W21	770-007S206W1
178-1-H	770-007S206
178-1-G-W24	770-007S106R
178-1-G-WM250	770-007S106W2
178-1-G-W8	770-007S106W1
178-1-G-W17	770-007S106W1
178-1-G-W21	770-007S106W1
178-1-G	770-007S106
178-1-B7-WM250	770-007S706W2
178-1-B7-WM250	770-007S706W2
178-1-B7-W17	770-007S706W1
178-1-B7-W21	770-007S706W1
178-1-B7	770-007S706
178-1-J-WM250	770-007S306W2
178-1-J-WM250	770-007S306W2
178-1-J-W17	770-007S306W1
178-1-J-W21	770-007S306W1
178-1-J	770-007S306
179-1-H-WM250	770-007S207W2

Hellermann Part Number	Glenair Part Number
179-1-H-W8	770-007S207W1
179-1-H-W17	770-007S207W1
179-1-H-W21	770-007S207W1
179-1-H	770-007S207
179-1-G-W24	770-007S107R
179-1-G-WM250	770-007S107W2
179-1-G-W8	770-007S107W1
179-1-G-W17	770-007S107W1
179-1-G-W21	770-007S107W1
179-1-G	770-007S107
179-1-B7-WM250	770-007S707W2
179-1-B7-WM250	770-007S707W2
179-1-B7-W17	770-007S707W1
179-1-B7-W21	770-007S707W1
179-1-B7	770-007S707
179-1-J-WM250	770-007S307W2
179-1-J-WM250	770-007S307W2
179-1-J-W17	770-007S307W1
179-1-J-W21	770-007S307W1
179-1-J	770-007S307
313E445-8-WM250	770-019SB501W2
313E445-8-W24	770-019SB501R
313E445-8-W8	770-019SB501W1
313E445-8-W17	770-019SB501W1
313E445-8-W21	770-019SB501W1
313E445-8	770-019SB501
	770-019SB601W3
313E445-9-WM250	770-019SB601W2
313E445-9-W24	770-019SB601R
313E445-9-W8	770-019SB601W1
313E445-9-W17	770-019SB601W1
313E445-9-W21	770-019SB601W1





Hellerman to Glenair Part Number Cross Reference

Hellermann Part Number	Glenair Part Number
313E445-9	770-019SB601
313E447-8-WM250	770-019SB502W2
313E447-8-W24	770-019SB502R
313E447-8-W8	770-019SB502W1
313E447-8-W17	770-019SB502W1
313E447-8-W21	770-019SB502W1
313E447-8	770-019SB502
313E447-9-WM250	770-019SB602W2
313E447-9-W24	770-019SB602R
313E447-9-W8	770-019SB602W1
313E447-9-W17	770-019SB602W1
313E447-9-W21	770-019SB602W1
313E447-9	770-019SB602
313E455-8-WM250	770-019SB503W2
313E455-8-W24	770-019SB503R
313E455-8-W8	770-019SB503W1
313E455-8-W17	770-019SB503W1
313E455-8-W21	770-019SB503W1
313E455-8	770-019SB503
313E455-9-WM250	770-019SB603W2
313E455-9-W24	770-019SB603R
313E455-9-W8	770-019SB603W1
313E455-9-W17	770-019SB603W1
313E455-9-W21	770-019SB603W1
313E455-9	770-019SB603
313E457-8-WM250	770-019SB504W2
313E457-8-W24	770-019SB504R
313E457-8-W8	770-019SB504W1
313E457-8-W17	770-019SB504W1
313E457-8-W21	770-019SB504W1
313E457-8	770-019SB504
313E457-9-WM250	770-019SB604W2

Hellermann Part Number	Glenair Part Number
313E457-9-W24	770-019SB604R
313E457-9-W8	770-019SB604W1
313E457-9-W17	770-019SB604W1
313E457-9-W21	770-019SB604W1
313E457-9	770-019SB604
313F322-8	770-020S502
313F322-8-WM250	770-020S502W2
313F322-8-W24	770-020S502R
313F322-8-W8	770-020S502W1
313F322-8-W17	770-020S502W1
313F322-8-W21	770-020S502W1
313F322-9	770-020S602
313F322-9-WM250	770-020S602W2
313F322-9-W8	770-020S602W1
313F322-9-W17	770-020S602W1
313F322-9-W21	770-020S602W1
313F322-9-W24	770-020S602R
313F332-8-W24	770-020S503R
313F332-8-W8	770-020S503W1
313F332-8-W17	770-020S503W1
313F332-8-W21	770-020S503W1
313F332-8	770-020S503
313F332-8-WM250	770-020S503W2
313F332-9-W24	770-020S603R
313F332-9-WM250	770-020S603W2
313F332-9-W8	770-020S603W1
313F332-9-W17	770-020S603W1
313F332-9-W21	770-020S603W1
313F332-9	770-020S603
313F343-8-W24	770-020S504R
313F343-8-W8	770-020S504W1
313F343-8-W17	770-020S504W1



Hellerman to Glenair Part Number Cross Reference

Hellermann Part Number	Glenair Part Number
313F343-8-W21	770-020S504W1
313F343-8	770-020S504
313F343-8-WM250	770-020S504W2
313F343-9-W24	770-020S604R
313F343-9-WM250	770-020S604W2
313F343-9-W8	770-020S604W1
313F343-9-W17	770-020S604W1
313F343-9-W21	770-020S604W1
313F343-9	770-020S604
313F353-8-WM250	770-020S505W2
313F353-8-W24	770-020S505R
313F353-8-W8	770-020S505W1
313F353-8-W17	770-020S505W1
313F353-8-W21	770-020S505W1
313F353-8	770-020S505
313F353-9-W24	770-020S605R
313F353-9-WM250	770-020S605W2
313F353-9-W8	770-020S605W1
313F353-9-W17	770-020S605W1
313F353-9-W21	770-020S605W1
313F353-9	770-020S605
313F364-8-W24	770-020S506R
313F364-8-W8	770-020S506W1
313F364-8	770-020S506
313F364-8-WM250	770-020S506W2
313F364-9-WM250	770-020S606W2
313F364-9-W8	770-020S606W1
313F364-9-W17	770-020S606W1
313F364-9-W21	770-020S606W1
313F364-9	770-020S606
313F374-8-WM250	770-020S507W2
313F374-8-W24	770-020S507R

Hellermann Part Number	Glenair Part Number
313F374-8-W8	770-020S507W1
313F374-8-W17	770-020S507W1
313F374-8-W21	770-020S507W1
313F374-8	770-020S507
313F374-9-WM250	770-020S607W2
313F374-9-W8	770-020S607W1
313F374-9-W17	770-020S607W1
313F374-9-W21	770-020S607W1
313F374-9	770-020S607
313F385-8-WM250	770-020S508W2
313F385-8-W24	770-020S508R
313F385-8-W8	770-020S508W1
313F385-8-W17	770-020S508W1
313F385-8-W21	770-020S508W1
313F385-8	770-020S508
313F385-9-WM250	770-020S608W2
313F385-9-W8	770-020S608W1
313F385-9-W17	770-020S608W1
313F385-9-W21	770-020S608W1
313F385-9	770-020S608
152-42-H-WM250	770-001S203W2
152-42-H-W8	770-001S203W1
152-42-H-W17	770-001S203W1
152-42-H-W21	770-001S203W1
152-42-H	770-001S203
152-41-H-W17	770-002S203W1
152-41-H	770-002S203
152-42-G-W24	770-001S103R
152-42-G-WM250	770-001S103W2
152-42-G-W8	770-001S103W1
152-42-G-W17	770-001S103W1
152-42-G-W21	770-001S103W1





Hellerman to Glenair Part Number Cross Reference

Hellermann Part Number	Glenair Part Number
152-42-G	770-001S103
152-41-G-W24	770-002S103R
152-41-G-WM250	770-002S103W2
152-41-G-W8	770-002S103W1
152-41-G	770-002S103
152-42-B7-WM250	770-001S703W2
152-42-B7-WM250	770-001S703W2
152-42-B7-W17	770-001S703W1
152-42-B7-W21	770-001S703W1
152-42-B7	770-001S703
152-41-B7-WM250	770-002S703W2
152-41-B7-WM250	770-002S703W2
152-41-B7-W17	770-002S703W1
152-41-B7-W21	770-002S703W1
152-41-B7	770-002S703
152-42-J-WM250	770-001S303W2
152-42-J-WM250	770-001S303W2
152-42-J-W17	770-001S303W1
152-42-J-W21	770-001S303W1
152-42-J	770-001S303
152-41-J-W8	770-002S303W2
152-41-J-WM250	770-002S303W2
152-41-J	770-002S303
154-42-H-WM250	770-001S204W2
154-42-H	770-001S204
154-41-H-WM250	770-002S204W2
154-41-H	770-002S204
154-42-G-W24	770-001S104R
154-42-G-WM250	770-001S104W2
154-42-G-W8	770-001S104W1
154-42-G-W17	770-001S104W1
154-42-G-W21	770-001S104W1

Hellermann Part Number	Glenair Part Number
154-42-G	770-001S104
154-41-G-W24	770-002S104R
154-41-G-WM250	770-002S104W2
154-41-G-W8	770-002S104W1
154-41-G	770-002S104
154-42-B7-WM250	770-001S704W2
154-42-B7-WM250	770-001S704W2
154-42-B7-W17	770-001S704W1
154-42-B7-W21	770-001S704W1
154-42-B7	770-001S704
154-41-B7-WM250	770-002S704W2
154-41-B7-WM250	770-002S704W2
154-41-B7	770-002S704
154-42-J-WM250	770-001S304W2
154-42-J-WM250	770-001S304W2
154-42-J-W17	770-001S304W1
154-42-J	770-001S304
154-41-J-WM250	770-002S304W2
154-41-J	770-002S304
155-42-H-WM250	770-001S205W2
155-42-H-W8	770-001S205W1
155-42-H-W17	770-001S205W1
155-42-H-W21	770-001S205W1
155-42-H	770-001S205
155-41-H-WM250	770-002S205W2
155-41-H	770-002S205
155-42-G-W24	770-001S105R
155-42-G-WM250	770-001S105W2
155-42-G-W8	770-001S105W1
155-42-G-W17	770-001S105W1
155-42-G-W21	770-001S105W1
155-42-G	770-001S105



Hellerman to Glenair Part Number Cross Reference

Hellermann Part Number	Glenair Part Number
155-41-G-W24	770-002S105R
155-41-G-WM250	770-002S105W2
155-41-G-W8	770-002S105W1
155-41-G	770-002S105
155-42-B7-WM250	770-001S705W2
155-42-B7-WM250	770-001S705W2
155-42-B7-W17	770-001S705W1
155-42-B7-W21	770-001S705W1
155-42-B7	770-001S705
155-41-B7-WM250	770-002S705W2
155-41-B7-WM250	770-002S705W2
155-41-B7	770-002S705
155-42-J	770-001S305W2
155-42-J-WM250	770-001S305W2
155-42-J-W8	770-001S305W1
155-42-J-W17	770-001S305W1
155-42-J-W21	770-001S305W1
155-42-J	770-001S305
155-41-J-WM250	770-002S305W2
155-41-J	770-002S305
156-42-H-WM250	770-001S206W2
156-42-H	770-001S206
156-41-H-WM250	770-002S206W2
156-41-H	770-002S206
156-42-G-W24	770-001S106R
156-42-G-WM250	770-001S106W2
156-42-G-W8	770-001S106W1
156-42-G	770-001S106
156-41-G-W24	770-002S106R
156-41-G-WM250	770-002S106W2
156-41-G-W8	770-002S106W1
156-41-G	770-002S106

Hellermann Part Number	Glenair Part Number
156-42-B7-WM250	770-001S706W2
156-42-B7-WM250	770-001S706W2
156-42-B7-W17	770-001S706W1
156-42-B7-W21	770-001S706W1
156-42-B7	770-001S706
156-41-B7-WM250	770-002S706W2
156-41-B7-WM250	770-002S706W2
156-41-B7	770-002S706
156-42-J-WM250	770-001S306W2
156-42-J-W17	770-001S306W1
156-42-J-W21	770-001S306W1
156-42-J	770-001S306
156-41-J	770-002S306
157-43-H-WM250	770-001S207W2
157-43-H	770-001S207
157-42-H-WM250	770-002S207W2
157-42-H	770-002S207
157-43-G-W24	770-001S107R
157-43-G-WM250	770-001S107W2
157-43-G-W8	770-001S107W1
157-43-G	770-001S107
157-42-G-W24	770-002S107R
157-42-G-WM250	770-002S107W2
157-42-G-W8	770-002S107W1
157-42-G	770-002S107
157-43-B7-WM250	770-001S707W2
157-43-B7-WM250	770-001S707W2
157-43-B7	770-001S707
157-42-B7-WM250	770-002S707W2
157-42-B7-WM250	770-002S707W2
157-42-B7	770-002S707
157-43-J-WM250	770-001S307W2





Hellerman to Glenair Part Number Cross Reference

Hellermann Part Number	Glenair Part Number
157-43-J-WM250	770-001S307W2
157-43-J-W17	770-001S307W1
157-43-J-W21	770-001S307W1
157-43-J	770-001S307
157-42-J-WM250	770-002S307W2
157-42-J	770-002S307
158-43-H-WM250	770-001S208W2
158-43-H	770-001S208
158-41-H-WM250	770-002S208W2
158-41-H	770-002S208
158-43-G-W24	770-001S108R
158-43-G-WM250	770-001S108W2
158-43-G-W8	770-001S108W1
158-43-G	770-001S108
158-41-G-W24	770-002S108R
158-41-G-WM250	770-002S108W2
158-41-G-W8	770-002S108W1
158-41-G	770-002S108
158-43-B7-WM250	770-001S708W2
158-43-B7-WM250	770-001S708W2
158-43-B7-W17	770-001S708W1
158-43-B7-W21	770-001S708W1
158-43-B7	770-001S708
158-41-B7-WM250	770-002S708W2
158-41-B7-WM250	770-002S708W2
158-41-B7	770-002S708
158-43-J-WM250	770-001S308W2
158-43-J-WM250	770-001S308W2
158-43-J-W17	770-001S308W1
158-43-J-W21	770-001S308W1
158-43-J	770-001S308
158-41-J-WM250	770-002S308W2

Hellermann Part Number	Glenair Part Number
158-42-J-WM250	770-002S308W2
158-42-J	770-002S308
159-43-G-W24	770-001S109R
159-43-G-WM250	770-001S109W2
159-43-G-W8	770-001S109W1
159-43-G-W17	770-001S109W1
159-43-G-W21	770-001S109W1
159-43-G	770-001S109
159-43-B7-WM250	770-001S709W2
159-43-B7-WM250	770-001S709W2
159-43-B7-W24	770-001S709R
159-43-B7-W17	770-001S709W1
159-43-B7-W21	770-001S709W1
159-43-B7	770-001S709
159-43-J-WM250	770-001S309W2
159-43-J-WM250	770-001S309W2
159-43-J-W17	770-001S309W1
159-43-J-W21	770-001S309W1
159-43-J	770-001S309
1750-1-H-W17	770-008S200W1BLK
1751-1-H-W17	770-008S201W1BLK
1752-1-H-W17	770-008S202W1BLK
1753-1-H-W17	770-008S203W1BLK
1754-1-H-W17	770-008S204W1BLK
1755-1-H-W17	770-008S205W1BLK
1108-1-H-W17	770-005A202W1
1108-1-H	770-005A202
1108-1-G-W24	770-005A102R
1108-1-G-WM250	770-005A102W2
1108-1-G-W8	770-005A102W1
1108-1-G	770-005A102
1108-1-B7-WM250	770-005A702W2



Hellerman to Glenair Part Number Cross Reference

Hellermann Part Number	Glenair Part Number
1108-1-B7-W17	770-005A702W1
1108-1-B7-W21	770-005A702W1
1108-1-B7	770-005A702
1108-1-J-WM250	770-005A302W2
1108-1-J	770-005A302
1106-1-H-W17	770-005A203W1
1106-1-H	770-005A203
1106-1-G-W24	770-005A103R
1106-1-G-WM250	770-005A103W2
1106-1-G-W8	770-005A103W1
1106-1-G	770-005A103
1106-1-B7-WM250	770-005A703W2
1106-1-B7-W17	770-005A703W1
1106-1-B7-W21	770-005A703W1
1106-1-B7	770-005A703
1106-1-J-WM250	770-005A303W2
1106-1-J	770-005A303
1107-1-H-W17	770-005A204W1
1107-1-H	770-005A204
1107-1-G-W24	770-005A104R
1107-1-G-WM250	770-005A104W2
1107-1-G-W8	770-005A104W1
1107-1-G	770-005A104
1107-1-B7-WM250	770-005A704W2
1107-1-B7-W17	770-005A704W1
1107-1-B7-W21	770-005A704W1
1107-1-B7	770-005A704
1107-1-J-WM250	770-005A304W2
1107-1-J	770-005A304
1104-1-H-W17	770-005A205W1
1104-1-H	770-005A205
1104-1-G-W24	770-005A105R

Hellermann Part Number	Glenair Part Number
1104-1-G-WM250	770-005A105W2
1104-1-G-W8	770-005A105W1
1104-1-G	770-005A105
1104-1-B7-WM250	770-005A705W2
1104-1-B7-W17	770-005A705W1
1104-1-B7-W21	770-005A705W1
1104-1-B7	770-005A705
1104-1-J-WM250	770-005A305W2
1104-1-J	770-005A305
1103-1-H-W17	770-005A206W1
1103-1-H	770-005A206
1103-1-G-W24	770-005A106R
1103-1-G-WM250	770-005A106W2
1103-1-G-W8	770-005A106W1
1103-1-G	770-005A106
1103-1-B7-WM250	770-005A706W2
1103-1-B7-W17	770-005A706W1
1103-1-B7-W21	770-005A706W1
1103-1-B7	770-005A706
1103-1-J-WM250	770-005A306W2
1103-1-J	770-005A306
1101-1-H-W17	770-005A207W1
1101-1-H	770-005A207
1101-1-G-W24	770-005A107R
1101-1-G-WM250	770-005A107W2
1101-1-G-W8	770-005A107W1
1101-1-G	770-005A107
1101-1-B7-WM250	770-005A307W2
1101-1-B7-W17	770-005A307W1
1101-1-B7-W21	770-005A307W1
1101-1-B7	770-005A307
1101-1-J-WM250	770-005A307W2





Hellerman to Glenair Part Number Cross Reference

Hellermann Part Number	Glenair Part Number
1101-1-J	770-005A307
1105-1-H-W17	770-005A208W1
1105-1-H	770-005A208
1105-1-G-W24	770-005A108R
1105-1-G-WM250	770-005A108W2
1105-1-G-W8	770-005A108W1
1105-1-G	770-005A108
1105-1-B7-WM250	770-005A708W2
1105-1-B7-W17	770-005A708W1
1105-1-B7-W21	770-005A708W1
1105-1-B7	770-005A708
1105-1-J-WM250	770-005A308W2
1105-1-J	770-005A308
1106-4-H-W17	770-003A203W1
1106-4-H	770-003A203
1106-4-G-WM250	770-003A103W2
1106-4-G-W8	770-003A103W1
1106-4-G	770-003A103
1106-4-B7-WM250	770-003A703W2
1106-4-B7-WM250	770-003A703W2
1106-4-B7-W17	770-003A703W1
1106-4-B7-W21	770-003A703W1
1106-4-B7	770-003A703
1106-4-J-WM250	770-003A303W2
1106-4-J	770-003A303
1107-4-H-W17	770-003A204W1
1107-4-H	770-003A204
1107-4-G-W24	770-003A104R
1107-4-G-WM250	770-003A104W2
1107-4-G-W8	770-003A104W1
1107-4-G	770-003A104
1107-4-B7-WM250	770-003A704W2

Hellermann Part Number	Glenair Part Number
1107-4-B7-WM250	770-003A704W2
1107-4-B7-W17	770-003A704W1
1107-4-B7-W21	770-003A704W1
1107-4-B7	770-003A704
1107-4-J-WM250	770-003A304W2
1107-4-J	770-003A304
1104-4-H-W17	770-003A205W1
1104-4-H	770-003A205
1104-4-G-W24	770-003A105R
1104-4-G-WM250	770-003A105W2
1104-4-G-W8	770-003A105W1
1104-4-G	770-003A105
1104-4-B7-WM250	770-003A705W2
1104-4-B7-WM250	770-003A705W2
1104-4-B7-W17	770-003A705W1
1104-4-B7-W21	770-003A705W1
1104-4-B7	770-003A705
1104-4-J-WM250	770-003A305W2
1104-4-J	770-003A305
1103-4-H-W17	770-003A206W1
1103-4-H	770-003A206
1103-4-G-WM250	770-003A106W2
1103-4-G-W8	770-003A106W1
1103-4-G	770-003A106
1103-4-B7-WM250	770-003A706W2
1103-4-B7-WM250	770-003A706W2
1103-4-B7-W17	770-003A706W1
1103-4-B7-W21	770-003A706W1
1103-4-B7	770-003A706
1103-4-J-WM250	770-003A306W2
1103-4-J	770-003A306
1101-4-H-W17	770-003A207W1



Hellerman to Glenair Part Number Cross Reference

Hellermann Part Number	Glenair Part Number
1101-4-H	770-003A207
1101-4-G-W24	770-003A107R
1101-4-G-WM250	770-003A107W2
1101-4-G-W8	770-003A107W1
1101-4-G	770-003A107
1101-4-B7-WM250	770-003A707W2
1101-4-B7-WM250	770-003A707W2
1101-4-B7-W17	770-003A707W1
1101-4-B7-W21	770-003A707W1
1101-4-B7	770-003A707
1101-4-J-WM250	770-003A307W2
1101-4-J	770-003A307
1105-4-H-W17	770-003A208W1
1105-4-H	770-003A208
1105-4-G-W24	770-003A108R
1105-4-G-WM250	770-003A108W2
1105-4-G-W8	770-003A108W1
1105-4-G	770-003A108
1105-5-B7-WM250	770-003A708W2
1105-5-B7-WM250	770-003A708W2
1105-5-B7-W17	770-003A708W1
1105-5-B7-W21	770-003A708W1
1105-5-B7	770-003A708
1105-4-J-WM250	770-003A308W2
1105-4-J	770-003A308
1121-4-H-W17	770-006A202W1
1121-4-H	770-006A202
1121-4-G-W24	770-006A102R
1121-4-G-WM250	770-006A102W2
1121-4-G-W8	770-006A102W1
1121-4-G	770-006A102
1121-4-B7-WM250	770-006A702W2

Hellermann Part Number	Glenair Part Number
1121-4-B7-WM250	770-006A702W2
1121-4-B7-W17	770-006A702W1
1121-4-B7-W21	770-006A702W1
1121-4-B7	770-006A702
1121-4-J-WM250	770-006A302W2
1121-4-J	770-006A302
1122-4-H-W17	770-006A203W1
1122-4-H	770-006A203
1122-4-G-W24	770-006A103R
1122-4-G-WM250	770-006A103W2
1122-4-G-W8	770-006A103W1
1122-4-G	770-006A103
1122-4-B7-WM250	770-006A703W2
1122-4-B7-WM250	770-006A703W2
1122-4-B7-W17	770-006A703W1
1122-4-B7-W21	770-006A703W1
1122-4-B7	770-006A703
1122-4-J-WM250	770-006A303W2
1122-4-J	770-006A303
1123-4-G-W24	770-006A104R
1123-4-G-WM250	770-006A104W2
1123-4-G-W8	770-006A104W1
1123-4-G	770-006A104
1123-4-B7-WM250	770-006A704W2
1123-4-B7-WM250	770-006A704W2
1123-4-B7-W17	770-006A704W1
1123-4-B7-W21	770-006A704W1
1121-4-B7	770-006A704
1123-4-J-WM250	770-006A304W2
1123-4-J	770-006A304
1124-4-G-W24	770-006A105R
1124-4-G-WM250	770-006A105W2





Hellerman to Glenair Part Number Cross Reference

Hellermann Part Number	Glenair Part Number
1124-4-G-W8	770-006A105W1
1124-4-G	770-006A105
1124-4-B7-WM250	770-006A705W2
1124-4-B7-WM250	770-006A705W2
1124-4-B7-W17	770-006A705W1
1124-4-B7-W21	770-006A705W1
1124-4-B7	770-006A705
1124-4-J-WM250	770-006A305W2
1124-4-J	770-006A305
1125-4-G-W24	770-006A106R
1125-4-G-WM250	770-006A106W2
1125-4-G-W8	770-006A106W1
1125-4-G	770-006A106
1125-4-B7-WM250	770-006A706W2
1125-4-B7-WM250	770-006A706W2
1125-4-B7-W17	770-006A706W1
1125-4-B7-W21	770-006A706W1
1125-4-B7	770-006A706
1125-4-J-WM250	770-006A306W2
1125-4-J	770-006A306
1126-4-G-W24	770-006A107R
1126-4-G-WM250	770-006A107W2
1126-4-G-W8	770-006A107W1
1126-4-G	770-006A107
1126-4-B7-WM250	770-006A707W2
1126-4-B7-WM250	770-006A707W2
1126-4-B7-W17	770-006A707W1
1126-4-B7-W21	770-006A707W1
1126-4-B7	770-006A707
1126-4-J-WM250	770-006A307W2
1126-4-J	770-006A307
1127-4-G-W24	770-006A108R

Hellermann Part Number	Glenair Part Number
1127-4-G-WM250	770-006A108W2
1127-4-G-W8	770-006A108W1
1127-4-G	770-006A108
1127-4-B7-WM250	770-006A708W2
1127-4-B7-WM250	770-006A708W2
1127-4-B7-W17	770-006A708W1
1127-4-B7-W21	770-006A708W1
1127-4-B7	770-006A708
1127-4-J-WM250	770-006A308W2
1127-4-J	770-006A308
1133-1-H-W17	770-007A203W1
1133-1-H	770-007A203
1133-1-G-W24	770-007A103R
1133-1-G-WM250	770-007A103W2
1133-1-G-W8	770-007A103W1
1133-1-G	770-007A103
1133-1-B7-WM250	770-007A703W2
1133-1-B7-W17	770-007A703W1
1133-1-B7-W21	770-007A703W1
1133-1-B7	770-007A703
1133-1-J-WM250	770-007A303W2
1133-1-J	770-007A303
1134-1-H-W17	770-007A204W1
1134-1-H	770-007A204
1134-1-G-W24	770-007A104R
1134-1-G-WM250	770-007A104W2
1134-1-G-W8	770-007A104W1
1134-1-G	770-007A104
1134-1-B7-WM250	770-007A704W2
1134-1-B7-W17	770-007A704W1
1134-1-B7-W21	770-007A704W1
1134-1-B7	770-007A704



Hellerman to Glenair Part Number Cross Reference

Hellermann Part Number	Glenair Part Number
1134-1-J-WM250	770-007A304W2
1134-1-J	770-007A304
1135-1-H-W17	770-007A206W1
1135-1-H	770-007A206
1135-1-G-W24	770-007A106R
1135-1-G-WM250	770-007A106W2
1135-1-G-W8	770-007A106W1
1135-1-G	770-007A106
1135-1-B7-WM250	770-007A706W2
1135-1-B7-W17	770-007A706W1
1135-1-B7-W21	770-007A706W1
1135-1-B7	770-007A706
1135-1-J-WM250	770-007A306W2
1135-1-J	770-007A306
1136-1-H-W17	770-007A207W1
1136-1-H	770-007A207
1136-1-G-W24	770-007A107R
1136-1-G-WM250	770-007A107W2
1136-1-G-W8	770-007A107W1
1136-1-G	770-007A107
1136-1-B7-WM250	770-007A707W2
1136-1-B7-W17	770-007A707W1
1136-1-B7-W21	770-007A707W1
1136-1-B7	770-007A707
1136-1-J-WM250	770-007A307W2
1136-1-J	770-007A307
333F322-8	770-021A502
333F322-9	770-021A602
333F332-8	770-021A503
333F332-9	770-021A603
333F343-8	770-021A504
333F343-9	770-021A604

Hellermann Part Number	Glenair Part Number
333F353-8	770-021A505
333F353-9	770-021A605
333F364-8	770-021A506
333F364-9	770-021A606
333F374-8	770-021A507
333F374-9	770-021A607
333F385-8	770-021A508
333F385-9	770-021A608
1152-4-H-WM250	770-001A203W2
1152-4-H-W17	770-001A203W1
1152-4-H-W21	770-001A203W1
1152-4-H	770-001A203
1152-4-G-W24	770-001A103R
1152-4-G-WM250	770-001A103W2
1152-4-G-W17	770-001A103W1
1152-4-G-W21	770-001A103W1
1152-4-G	770-001A103
1152-4-B7-WM250	770-001A703W2
1152-4-B7-WM250	770-001A703W2
1152-4-B7-W17	770-001A703W1
1152-4-B7-W21	770-001A703W1
1152-4-B7	770-001A703
1152-4-J-WM250	770-001A303W2
1152-4-J	770-001A303
1154-4-H-WM250	770-001A204W2
1154-4-H	770-001A204
1154-4-G-W24	770-001A104R
1154-4-G-WM250	770-001A104W2
1154-4-G-W17	770-001A104W1
1154-4-G-W21	770-001A104W1
1154-4-G	770-001A104
1154-4-B7-WM250	770-001A704W2





Hellerman to Glenair Part Number Cross Reference

Hellermann Part Number	Glenair Part Number
1154-4-B7-WM250	770-001A704W2
1154-4-B7-W17	770-001A704W1
1154-4-B7-W21	770-001A704W1
1154-4-B7	770-001A704
1154-4-J-WM250	770-001A304W2
1154-4-J	770-001A304
1155-4-H-WM250	770-001A205W2
1155-4-H	770-001A205
1155-4-G-W24	770-001A105R
1155-4-G-WM250	770-001A105W2
1155-4-G-W17	770-001A105W1
1155-4-G-W21	770-001A105W1
1155-4-G	770-001A105
1155-4-B7-WM250	770-001A705W2
1155-4-B7-WM250	770-001A705W2
1155-4-B7-W17	770-001A705W1
1155-4-B7-W21	770-001A705W1
1155-4-B7	770-001A705
1155-4-J-WM250	770-001A305W2
1155-4-J	770-001A305
1156-4-H-WM250	770-001A206W2
1156-4-H	770-001A206
1156-4-G-W24	770-001A106R
1156-4-G-WM250	770-001A106W2
1156-4-G-W17	770-001A106W1
1156-4-G-W21	770-001A106W1
1156-4-G	770-001A106
1156-4-B7-WM250	770-001A706W2
1156-4-B7-WM250	770-001A706W2
1156-4-B7-W17	770-001A706W1
1156-4-B7-W21	770-001A706W1
1156-4-B7	770-001A706

Hellermann Part Number	Glenair Part Number
1156-4-J-WM250	770-001A306W2
1156-4-J	770-001A306
1157-4-H-WM250	770-001A207W2
1157-4-H	770-001A207
1157-4-G-W24	770-001A107R
1157-4-G-WM250	770-001A107W2
1157-4-G-W17	770-001A107W1
1157-4-G-W21	770-001A107W1
1157-4-G	770-001A107
1156-4-B7-WM250	770-001A707W2
1156-4-B7-WM250	770-001A707W2
1156-4-B7-W17	770-001A707W1
1156-4-B7-W21	770-001A707W1
1156-4-B7	770-001A707
1157-4-J-WM250	770-001A307W2
1157-4-J	770-001A307
1158-4-H-WM250	770-001A208W2
1158-4-H	770-001A208
1158-4-G-W24	770-001A108R
1158-4-G-WM250	770-001A108W2
1158-4-G-W17	770-001A108W1
1158-4-G-W21	770-001A108W1
1158-4-G	770-001A108
1158-5-B7-WM250	770-001A708W2
1158-5-B7-WM250	770-001A708W2
1158-5-B7-W17	770-001A708W1
1158-5-B7-W21	770-001A708W1
1158-5-B7	770-001A708
1158-4-J-WM250	770-001A308W2
1158-4-J	770-001A308
1159-4-G-W24	770-001A109R
1159-4-G-WM250	770-001A109W2



Hellerman to Glenair Part Number Cross Reference

Hellermann Part Number	Glenair Part Number
1159-8-G-W17	770-001A109W1
1159-8-G-W21	770-001A109W1
1159-8-G	770-001A109
1159-8-B7-WM250	770-001A709W2
1159-8-B7-WM250	770-001A709W2
1159-8-B7-W17	770-001A709W1
1159-8-B7-W21	770-001A709W1
1159-8-B7	770-001A709
1159-8-J-WM250	770-001A309W2
1159-8-J-WM250	770-001A309W2
1159-8-J-W17	770-001A309W1
1159-8-J-W21	770-001A309W1
1159-8-J	770-001A309
1301-1-B7	770-037T710
1301-1-B7-WM250	770-037T710W2
1301-1-B7-W17	770-037T710W1
1301-1-B7-W21	770-037T710W1
1301-1-J	770-037T310
1301-1-J-WM250	770-037T310W2
1301-1-J-W17	770-037T310W1
1301-1-J-W21	770-037T310W1
1301-1-G	770-037T110
1301-1-G-W17	770-037T110W1
1301-1-G-W21	770-037T110W1
1301-1-G-W24	770-037T110R
1301-1-B7	770-037T710
1301-1-B7-WM250	770-037T710W2
1301-1-B7-W17	770-037T710W1
1301-1-B7-W21	770-037T710W1
1301-1-H	770-037T210
1301-1-H-WM250	770-037T210W2
1301-1-H-W17	770-037T210W1

Hellermann Part Number	Glenair Part Number
1301-1-H-W21	770-037T210W1
1302-1-B7	770-037T711
1302-1-B7-WM250	770-037T711W2
1302-1-B7-W17	770-037T711W1
1302-1-B7-W21	770-037T711W1
1302-1-J	770-037T311
1302-1-J-WM250	770-037T311W2
1302-1-J-W17	770-037T311W1
1302-1-J-W21	770-037T311W1
1302-1-G	770-037T111
1302-1-G-W17	770-037T111W1
1302-1-G-W21	770-037T111W1
1302-1-G-W24	770-037T111R
1302-1-B7	770-037T711
1302-1-B7-WM250	770-037T711W2
1302-1-B7-W17	770-037T711W1
1302-1-B7-W21	770-037T711W1
1302-1-H	770-037T211
1302-1-H-WM250	770-037T211W2
1302-1-H-W17	770-037T211W1
1302-1-H-W21	770-037T211W1
1303-1-B7	770-037T712
1303-1-B7-WM250	770-037T712W2
1303-1-B7-W17	770-037T712W1
1303-1-B7-W21	770-037T712W1
1303-1-J	770-037T312
1303-1-J-WM250	770-037T312W2
1303-1-J-W17	770-037T312W1
1303-1-J-W21	770-037T312W1
1303-1-G	770-037T121
1303-1-G-W17	770-037T121W1
1303-1-G-W21	770-037T121W1





Hellerman to Glenair Part Number Cross Reference

Hellermann Part Number	Glenair Part Number
1303-1-G-W24	770-037T121R
1303-1-B7	770-037T712
1303-1-B7-WM250	770-037T712W2
1303-1-B7-W17	770-037T712W1
492H412-8	770-009Y505
492H412-9-WM250	770-009Y605W2
492H412-9-W8	770-009Y605W1
492H412-9	770-009Y605
492H413-8	770-009Y506
492H413-9	770-009Y606W3
492H413-9-WM250	770-009Y606W2
492H413-9-W8	770-009Y606W1
492H413-9	770-009Y606
492H414-8	770-009Y507
492H414-9-WM250	770-009Y607W2
492H414-9	770-009Y607
492H415-8	770-009Y508
492H415-9-WM250	770-009Y608W2
492H415-9	770-009Y608
206-1-H-W17	770-010Y205W1
206-1-H-W21	770-010Y205W1
206-4-H	770-010Y205
206-4-G-W24	770-010Y105R
206-4-G-WM250	770-010Y105W2
206-4-G-W17	770-010Y105W1
206-4-G-W21	770-010Y105W2
206-4-G	770-010Y105
206-4-B7-WM250	770-010Y705W2
206-4-B7-W17	770-010Y705W1
206-4-B7-W21	770-010Y705W1
206-4-B7	770-010Y705
206-4-J-WM250	770-010Y305W2

Hellermann Part Number	Glenair Part Number
206-4-J-WM250	770-010Y305W2
206-4-J-W17	770-010Y305W1
206-4-J-W21	770-010Y305W1
206-4-J	770-010Y305
203-1-H-WM250	770-010Y206W2
203-1-H-W17	770-010Y206W1
203-1-H-W21	770-010Y206W1
203-1-H	770-010Y206
203-1-G-W24	770-010Y106R
203-1-G-WM250	770-010Y106W2
203-1-G-W17	770-010Y106W1
203-1-G-W21	770-010Y106W1
203-1-G	770-010Y106
203-1-B7-WM250	770-010Y706W2
203-1-B7-W17	770-010Y706W1
203-1-B7-W21	770-010Y706W1
203-1-B7	770-010Y706
203-1-J-WM250	770-010Y306W2
203-1-J-WM250	770-010Y306W2
203-1-J-W17	770-010Y306W1
203-1-J-W21	770-010Y306W1
203-1-B7	770-010Y306
204-1-H-WM250	770-010Y207W2
204-1-H-W17	770-010Y207W1
204-1-H-W21	770-010Y207W1
204-1-H	770-010Y207
204-1-G-W24	770-010Y107R
204-1-G-WM250	770-010Y107W2
204-1-G-W17	770-010Y107W1
204-1-G-W21	770-010Y107W1
204-1-G	770-010Y107
204-1-B7-WM250	770-010Y707W2



Hellerman to Glenair Part Number Cross Reference

Hellermann Part Number	Glenair Part Number
204-1-B7-W17	770-010Y707W1
204-1-B7-W21	770-010Y707W1
204-1-B7	770-010Y707
204-1-J-WM250	770-010Y307W2
204-1-J-WM250	770-010Y307W2
204-1-J-W17	770-010Y307W1
204-1-J-W21	770-010Y307W1
204-1-J	770-010Y307
306-1-H-WM250	770-013209W2
306-1-H-W17	770-013209W1
306-1-H-W21	770-013209W1
306-1-H	770-013209
306-1-G-W24	770-013109R
306-1-G-WM250	770-013109W2
306-1-G-W17	770-013109W1
306-1-G-W21	770-013109W1
306-1-G	770-013109
306-1-B7-WM250	770-013709W2
306-1-B7-W17	770-013709W1
306-1-B7-W21	770-013709W1
306-1-B7	770-013709
306-1-J-WM250	770-013309W2
306-1-J-WM250	770-013309W2
306-1-J-W17	770-013309W1
306-1-J-W21	770-013309W1
306-1-J	770-013309
304-1-H-WM250	770-013210W2
304-1-H-W17	770-013210W1
304-1-H-W21	770-013210W1
304-1-H	770-013210
304-1-G-W24	770-013110R
304-1-G-WM250	770-013110W2

Hellermann Part Number	Glenair Part Number
304-1-G-W17	770-013110W1
304-1-G-W21	770-013110W1
304-1-G	770-013110
304-1-B7-WM250	770-013710W2
304-1-B7-W17	770-013710W1
304-1-B7-W21	770-013710W1
304-1-B7	770-013710
304-1-J-WM250	770-013310W2
304-1-J-WM250	770-013310W2
304-1-J-W17	770-013310W1
304-1-J-W21	770-013310W1
304-1-J	770-013310
310-1-H-WM250	770-013211W2
310-1-H-W17	770-013211W1
310-1-H-W21	770-013211W1
310-1-H	770-013211
310-1-G-W24	770-013111R
310-1-G-WM250	770-013111W2
310-1-G-W17	770-013111W1
310-1-G-W21	770-013111W1
310-1-G	770-013111
310-1-B7-WM250	770-013711W2
310-1-B7-W17	770-013711W1
310-1-B7-W21	770-013711W1
310-1-B7	770-013711
310-1-J-WM250	770-013311W2
310-1-J-WM250	770-013311W2
310-1-J-W17	770-013311W1
310-1-J-W21	770-013311W1
310-1-J	770-013311
311-1-WM250	770-013212W2
311-1-W17	770-013212W1





Hellerman to Glenair Part Number Cross Reference

Hellermann Part Number	Glenair Part Number
311-1-W21	770-013212W1
311-1	770-013212
573H532-8	770-014509
573H532-9-W8	770-014609W1
573H532-9	770-014609
573H533-8	770-014510
573H533-9-W8	770-014610W1
573H533-9	770-014610
573H534-8	770-014511
573H534-9	770-014611
411-1-H-WM250	770-015215W2
411-1-H-W17	770-015215W1
411-1-H-W21	770-015215W1
411-1-H	770-015215
411-1-G-W24	770-015115R
411-1-G-WM250	770-015115W2
411-1-G-W17	770-015115W1
411-1-G-W21	770-015115W1
411-1-G	770-015115
411-1-B7-WM250	770-015715W2
411-1-B7-W17	770-015715W1
411-1-B7-W21	770-015715W1
411-1-B7	770-015715
411-1-J-WM250	770-015315W2
411-1-J-W17	770-015315W1
411-1-J-W21	770-015315W1
411-1-J	770-015315
403-1-H-WM250	770-015217W2
403-1-H-W17	770-015217W1
403-1-H-W21	770-015217W1
403-1-H	770-015217
403-1-G-W24	770-015117R

Hellermann Part Number	Glenair Part Number
403-1-G-WM250	770-015117W2
403-1-G-W17	770-015117W1
403-1-G-W21	770-015117W1
403-1-G	770-015117
403-1-B7-WM250	770-015717W2
403-1-B7-W17	770-015717W1
403-1-B7-W21	770-015717W1
403-1-B7	770-015717
403-1-J-WM250	770-015317W2
403-1-J-W17	770-015317W1
403-1-J-W21	770-015317W1
403-1-J	770-015317
413-1-H-WM250	770-015218W2
413-1-H-W17	770-015218W1
413-1-H-W21	770-015218W1
413-1-H	770-015218
413-1-G-W24	770-015118R
413-1-G-WM250	770-015118W2
413-1-G-W17	770-015118W1
413-1-G-W21	770-015118W1
413-1-G	770-015118
413-1-B7-WM250	770-015718W2
413-1-B7-W17	770-015718W1
413-1-B7-W21	770-015718W1
413-1-B7	770-015718
413-1-J-WM250	770-015318W2
413-1-J-W17	770-015318W1
413-1-J-W21	770-015318W1
413-1-J	770-015318



DURALECTRIC

AutoShrink™

The fast and easy cold-action shrink tubing solution from Glenair

Designed for rugged weathering, UV and ozone-resistant performance, Glenair AutoShrink is the one-piece easy-action solution for Turboflex™ cable and lug termination, splice insulation, and Duralectric® jacketing repair. Universal design AutoShrink tubing delivers reliable and durable sealing as well as mechanical protection for cable end terminations in harsh military and industrial applications. Built from Glenair Duralectric material, AutoShrink is fully hydrophobic and resistant to caustic chemicals and solvents. Easy-action spiral hold-out and large cold shrink ratio makes for fast installation and durable, split-resistant performance.

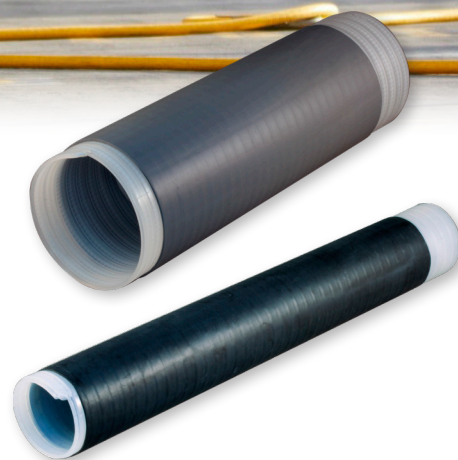

- **Fast and easy installation**
- **Ideal for repair of cables and conduit with Duralectric® jacketing**
- **Reliable IP68 sealing**
- **3000 VAC rated**
- **Multiple color options**
- **Service temperature range: -65°C to 225°C**
- **Fire-resistant, Low Smoke-Zero Halogen (LSZH)**
- **Mil-aero and industrial fluid-resistant**
- **Accelerated UV/sunlight resistant, 53 year equivalent exposure**
- **Ozone resistant IAW ASTM D518**



Fast and easy repair of Duralectric-jacketed cables

Utilize for termination of lugs on new installations

Broad range of colors for safety marking and cable identification

Fast cold-action shrink tubing

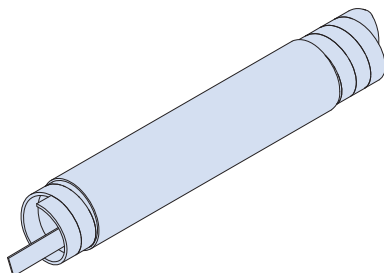

How To Order				
Sample Part Number	777-004	-01	-6	-0
Product Code-Basic No.	AutoShrink			
Size Code	See Table I			
Length	in Inches. 3" min., 12" max.			
Color Code	See Table II			

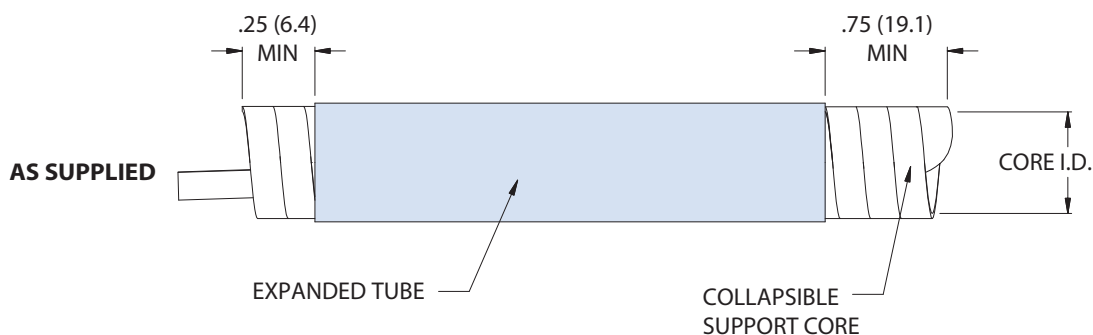

Note: 779-005 Adhesive (sold separately) may be specified for applications that require extraordinary environmental sealing performance

Dash No.	Tube I.D. after unrestricted shrinkage (ref)		As Supplied Core I.D.		Ref. Wire Bundle Range min / max	
	In.	mm	In.	mm	In.	mm
01	0.250	6.4	0.80	20.3	0.35 / 0.65	8.9 / 16.5
02	0.375	9.5	1.18	30.0	0.55 / 1.00	14.0 / 25.4
03	0.625	15.9	2.00	50.8	0.85 / 1.65	21.6 / 41.9
04	0.750	19.1	2.34	59.4	1.00 / 2.00	25.4 / 50.8
05	0.937	23.8	2.75	69.9	1.25 / 2.50	31.8 / 63.5
06	1.437	36.5	4.00	101.6	2.00 / 3.85	50.8 / 97.8

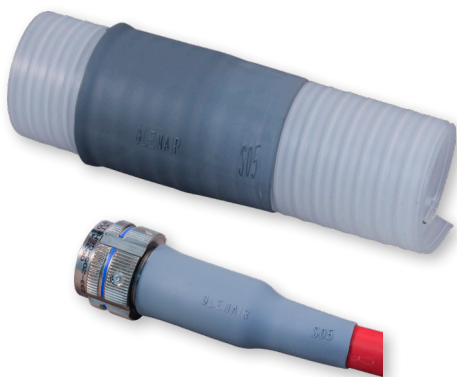

Sneak Peek: AutoShrink Boots
Fast, easy-to-install environmental sealing for cable-to-connector terminations. No heat gun needed! Designed for use with Duraelectric cable jacketing. Consult the factory for available sizes, styles, and colors.

Code	Color	Reference
0	Black	FED-STD-595C; #17038
1	Desert Tan	FED-STD-595C; #33446
2	Red	FED-STD-595C; #11120
3	Orange	FED-STD-595C; #12300
4	Yellow	FED-STD-595C; #13591
5	Green	FED-STD-595C; #14193
6	Blue	FED-STD-595C; #15125
7	Purple	FED-STD-595C; #17142
8	Gray	FED-STD-595C; #26270
9	White	FED-STD-595C; #17875

NOTES

- Length in expanded form may be less than length after unrestricted shrinkage.
- Material: Duraelectric per GPS67-E1
- Recovered dimension apply to unrestricted recovery. Dimensions may differ than shown when boots are installed over assembly.

WHY
CHOOSE

Glenair?



Plenty of Raw Materials!



Outstanding
Customer Service!



Abundant Machining Capacity!



In-House Assembly!



Huge "Same-Day" Inventory!

Glenair®

Glenair, Inc.
1211 Air Way
Glendale, CA
91201-2497
818-247-6000
sales@glenair.com
www.glenair.com



Out of This World
**INTERCONNECT
SOLUTIONS**

Glenair, Inc.

1211 Air Way • Glendale, California • 91201-2497

Telephone: 818-247-6000 • Fax: 818-500-9912 • sales@glenair.com

www.glenair.com

**Glenair Power
Products Group**

860 N. Main Street Extension
Wallingford, CT
06492

Telephone:
203-741-1115
Facsimile:
203-741-0053
sales@glenair.com

Glenair UK Ltd

40 Lower Oakham Way
Oakham Business Park
Mansfield, Notts
NG18 5BY England

Telephone:
+44-1623-638100
Facsimile:
+44-1623-638111
sales@glenair.co.uk

Glenair Microway Systems

7000 North Lawndale Avenue
Lincolnwood, IL
60712

Telephone:
847-679-8833
Facsimile:
847-679-8849

Glenair Nordic AB

Gustav III : S Boulevard 46
SE-169 27 Solna
Sweden

Telephone:
+46-8-50550000
sales@glenair.se

Glenair Electric GmbH

Schaberweg 28
61348 Bad Homburg
Germany

Telephone:
06172 / 68 16 0
Facsimile:
06172 / 68 16 90
info@glenair.de

Glenair Iberica

C/ La Vega, 16
45612 Velada
Spain

Telephone:
+34-925-89-29-88
Facsimile:
+34-925-89-29-87
sales@glenair.es

Glenair Italia S.p.A.

Via Del Lavoro, 7
40057 Quarto Inferiore –
Granarolo dell'Emilia
Bologna, Italy

Telephone:
+39-051-782811
Facsimile:
+39-051-782259
info@glenair.it

Glenair France SARL

7, Avenue Parmentier
Immeuble Central Parc #2
31200 Toulouse
France

Telephone:
+33-5-34-40-97-40
Facsimile:
+33-5-61-47-86-10
sales@glenair.fr

Glenair Korea

B-1304 Gunpo IT Valley
148 Gosan-Ro, Gunpo-Si
Kyunggi-Do, Korea
435-733

Telephone:
+82-31-8068-1090
Facsimile:
+82-31-8068-1092
sales@glenair.kr

