



High-temperature high-power-density inductors for automotive lighting

Akos Labady
Field applications engineer
Eaton

Overview

Light Emitting Diodes (LEDs) provide an efficient, dependable source of light in countless applications. The lack of moving parts makes them very reliable within environments that experience elevated vibration and shock, such as automobiles. LEDs possess other desirable properties including high efficiency, extended life and brightness. They are ideally suited to a variety of automotive applications including head and tail lamps, backlighting and liquid crystal displays (LCDs). Driven by the latest advancements in high-powered LEDs, industry experts anticipate the automotive lighting market to reach US\$27.7 billion by 2021¹.

The use of LEDs in automotive applications such as headlights, daytime running lights, rear brake lights and passenger compartment lights was limited by LED drivers, which supply power to the LEDs and protect them from voltage or current fluctuation. These drivers were mainly powered by Low-Drop-Out (LDO) DC linear voltage regulators, which were a simple, cost-effective means to regulate an output voltage powered from a higher voltage input. But LDOs were unable to support the high lumens required for headlights and running lights. The ambient temperatures prevalent within LED environments can reach and often exceed +125 °C. There was another issue with this technology. The high cost of the LEDs and drivers limited use to luxury vehicles.

Today, advanced LED driver designs are being developed with electronic components that deliver higher luminescence and improved energy efficiency at lower cost. Current components are typically a fraction of the cost compared to five years ago. Newer technology also has an operational advantage of approximately half the cost of halogen or Xenon. But the foremost feature is the flexibility and “cool” look that enhances the vehicle’s design and increases customer demand. These products enable manufacturers to develop higher-power LED headlight clusters that perform well at elevated current in a smaller footprint. Specific inductors support a more advanced LED driver design that handles higher voltages and a wider array of high-power LEDs that can operate “bend light” and dimming functions to improve roadway safety.

Eaton has a broad range of inductors that are technologically advanced to handle higher temperatures (up to +155 °C) and higher power density. The footprint can be decreased by as much as half with the newer inductors. A popular inductor used to require 12.5 mm x 12.5 mm on the board. Today’s version requires just 8 mm x 8.5 mm with the equivalent performance of several years ago. This competitive pricing generates significant opportunities for distributors to sell into manufacturers. Applications are becoming more and more sophisticated, trending well beyond two or three LED drivers per car. Today, full LED lighting solutions specifying 20 power inductors per board and 40 per car are not unrealistic.

It should be noted that the solutions discussed in this document are not commodity products. They must be designed into various automotive applications. In order to successfully optimize their designs, LED designers demand strong support from suppliers, distributors, and Eaton.



Powering Business Worldwide

SEPIC Circuit

A Single-Ended Primary Inductor Converter (SEPIC) allows the output voltage to be greater than, less than, or equal to the input voltage in DC-DC conversion.

Typical vehicular applications include daytime running lights (DRLs) and, more recently, full LED headlights, which supports all of the lighting options of low-beam, high-beam, fog and turning indicator lights using a single SEPIC driver circuit. This single circuit is able to output the optimal LED driver voltage and currents based on the actual number of light features turned on. Eaton's off-the-shelf AEC-Q200 Grade1 coupled inductors (DRAQ family) may power SEPIC drives of up to 40 W, which is sufficient for a standard LED headlamp. SEPIC drives make complete LED headlights affordable to the general public, not just luxury car drivers.

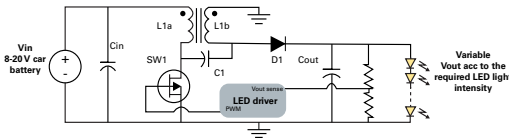

Figure 1. SEPIC circuit

Boost and Buck Circuit

Boost and Buck circuits are used for the most sophisticated LED headlights, providing sufficient power to drive multiple light features all the way up to 120 W per lamp. This type of circuit topology includes a powerful boost converter which normally boosts the battery voltage to a maximum 60 V. This elevated voltage is then bucked down to the required voltage level to power different LED strings of the headlight.

The different light strings may be composed of a matrix of uniform LEDs (normally 32-1024 pixels) or strings of power LEDs and some standalone power LEDs. These complex headlight units can control the light intensity based on the road conditions, driving speed, steering wheel position and upcoming traffic sensed by the Advanced Driver Assistance System (ADAS). The complex LED drivers adjust the light intensity and focus automatically for ride enhancing safety on the road, whether day or night.

Some laser LED diodes may illuminate all the way up to 600 meters, allowing high-speed driving during the evening. These drivers require robust inductors with high power density and 10-20 pieces per lamp to properly manage the various voltage and current requirements. When selecting components, it is important to choose those with high efficiency, high temperature capability, high heat dissipation capability and stable operation at all temperatures ranging from -40 °C to +125 °C ambient. Eaton's HCM(1)A inductor product line is designed specifically to take this challenge with a wide variety of inductances and size options.

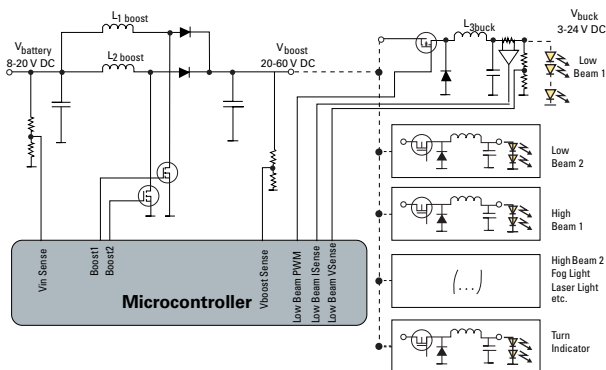

Figure 2. Boost and buck circuit

Identifying the Right Inductors for Challenging Applications

It is critical for manufacturers to work with suppliers who can deliver automotive-grade, high power inductors that offer low electromagnetic interference (EMI) and higher operating temperature, which are essential for obtaining efficient DC-DC

conversion. These robust inductors are designed to withstand harsh environmental, electrical, and mechanical conditions. Many of the more recent applications demand that the inductors perform at temperatures from -40 °C to +155 °C, representing the same inductance roll-off characteristics across the entire temperature range. Tight thermal coupling can ensure effective heat dissipation under high current conditions. Utilizing a variety of sizes and higher inductance values allows automotive designers to operate at higher voltages needed to drive multiple high-power LED arrays for headlights and daytime running lights.

With the rapid increase of automotive electronics components in vehicles, maintaining a low EMI is essential. Inductors are recommended to be magnetically shielded, making them suitable for virtually all applications throughout the vehicle. This gives automotive engineers design flexibility. Additionally, these inductors should be AEC-Q200 Grade-1 qualified and appropriate to operate in temperatures of up to +165 °C, making them popular for engine compartment applications including electric motors, pumps, and engine control modules, as well as for lighting body and security systems.

Solutions for Challenging Applications

Eaton has a wide range of standard inductors available for automotive lighting applications—even the most challenging. These components are available in a choice of core materials and manufacturing technologies.

DRA

Employing time-tested technology, the DRA remains the most efficient solution on the market today. The high-temperature, ferrite-based DRA features the lowest DCR, high Isat current, and enhanced shock and vibration performance, optimized for peak current operation. With its shielded drum core construction, the DRA can be manufactured to support up to 1000 uH inductance. That makes this inductor ideal for most automotive applications including LED lighting, powertrain control module (PCU), engine control unit (ECU), transmission control unit (TCU), and hybrid electric vehicle (HEV) inverter controller/charger.



DRAQ

The DRAQ inductor features two closely coupled windings with 200 V_{AC} winding isolation, and enhanced shock and vibration performance, which is optimized for best peak current operation. DRAQ is designed to function at +125 °C ambient and +165 °C total temperature operation. Typical applications include LED DRL, ADAS, Infotainment, radar power, and any SEPIC converters.

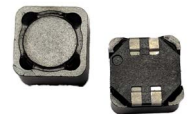

HCM(1)A

The HCM(1)A high-power-density inductors from Eaton boasts a lower core loss than other powdered iron solutions. It also possesses higher Isat, lower DCR, and soft roll-off characteristics. Using HCM(1)A inductors instead of DRAs helps to reduce the required PCB footprint to half since the HCM(1)A has higher power density and the performance is stable at all temperatures, allowing no derating at high temperature operations, which was a common practice using ferrite inductors. It is magnetically shielded to reduce EMI. The HCM(1)A operates at +85 °C ambient and the HCM1A operates at +125 °C ambient with a maximum total temperature of +125 °C and +155 °C respectively. It is optionally fully coated externally to provide 100 percent corrosion protection for harsh environments. Common applications include ECU, infotainment systems, TCU, LED lighting, water, fuel, and oil pumps, engine cooling fans, and HVAC units.



Summary

Advanced automotive-grade electronics are versatile, affordable, and provide the automotive engineer with more innovative solutions, adding flexibility to their designs and enabling new vehicle features and an enhanced driving experience. The opportunities in this market are significant for sales engineers willing to approach manufacturers, supported by Eaton's segment-leading range of automotive LED solutions.

Endnotes

¹Automotive lighting industry growth is driven by the introduction of disruptive technologies and consumer behavior changes, Yole Développement, May 2016, http://www.yole.fr/AutomotiveLighting_Market.aspx

Table 1. LED market analysis*

Grade	EATON	Dimensions (LxWxH)	Vishay	Würth	Bourns	TDK	Panasonic	Murata/Toko	Cyntec
AEC-Q200 G3 (+125 °C**)	MPIA25xxV2	2.7 x 2.2 x 1-1.2 mm			SRP251xA	TFM252012			VCTA25201B MS6
	MPIA40xxV2	4.7 x 4.5 x 1.2-2 mm	IHLP-1616xx-1A		SRP40xxTA				
	HCM A0503	5.1 x 5.1 x 3 mm	IHLP-2020CZ-1A		SRP5030TA				
	HCM A0703	6.8 x 7.1 x 3 mm	IHLP-2525CZ-1A	831 530 xxx	SRP07028A			DFEG7030D	
	HCM A1104	11 x 10 x 4 mm	IHLP-4040DZ-1A		SRP1038A			DFEG10040D	
	HCM A1105	11 x 10 x 5 mm		831 651 xxx					
	HCM A1305	13.3 x 12.2 x 5 mm	IHLP-5050EZ-A1	831 750 xxx	SRP1245A			DFEG12060D	
	HCM A1307	13.3 x 12.2 x 6.5 mm	IHLP-5050FD-A1		SRP1265A				
AEC-Q200 G1 (+155 °C**)	HCM1A0503	5.1 x 5.1 x 3 mm	IHLP-2020CZ-5A				ETQP3 YFP		VCMT053T MS6
	HCM1A0703	6.8 x 7.1 x 3 mm	IHLP-2525CZ-5A				ETQP3 YFN	DFEH7030D	VCMT063T MN5
	HCM1A0805	8.1x8.5x5.4mm	IHLP3232DZ-5A				ETQP5 YFK		VCHA075D MS6 VCHA085D MS6
	HCM1A1104	11 x 10 X 4 mm	IHLP-4040DZ-5A					DFEH10040D	VCMT104T MN5 VCM104T MN53
	HCM1A1305	13.3 x 12.2 x 5 mm	IHLP-5050EZ-5A						
	HCM1A1307	13.3 x 12.2 x 6.5 mm	IHLP-5050FD-5A				M1280MF	DFEH12060D	VCMT136E MN5
	HCM1A1707	17 x 17 X 7 mm	IHLP-6767GZ-5A						
	HCM1A4020V2	4.7 x 4.5 x 1.2-2 mm			SRP40xxTA				VCHA042A MS6
	HCM1A0503V2	5.1 x 5.1 x 3 mm	IHLP-2020CZ-5A				ETQP3 YFP		VCMT053T MS6
	HCM1A0703V2	6.8 x 7.1 x 3 mm	IHLP-2525CZ-5A				ETQP3 YFN	DFEH7030D	VCMT063T MN5
	HCM1A0805V2	8.1x8.5x5.4mm	IHLP3232DZ-5A				ETQP5 YFK		VCHA075D MS6 VCHA085D MS6
	HCM1A1104V2	11 x 10 X 4 mm	IHLP-4040DZ-5A					DFEH10040D	VCMT104T MN5 VCM104T MN53
	HCM1A1105V2	11 x 10 x 5 mm					ETQP5 YFC		VCHA105D MS6 VCM105T MS5
	HCM1A1305V2	13.3 x 12.2 x 5 mm	IHLP-5050EZ-5A						
	HCM1A1307V2	13.3 x 12.2 x 6.5 mm	IHLP-5050FD-5A				M1280MF	DFEH12060D	VCMT136E MN5
	HCM1A1707V2	17 x 17 X 7 mm	IHLP-6767GZ-5A						
	HCM1A2213V2	22 x 22 x 13 mm	IHLP-8787MZ-5A			SRP2313AA			

*2018 July Eaton 's electronics automotive components cross-over chart listing Eaton vs. competition.

**Total maximum temperature (ambient plus self-temperature rise)

Eaton
Electronics Division
 1000 Eaton Boulevard
 Cleveland, OH 44122
 United States
 Eaton.com/electronics

© 2019 Eaton
 All Rights Reserved
 Printed in USA
 Publication No. 10866 BU-MC19002
 January 2019

Eaton is a registered trademark.

All other trademarks are property of their respective owners.

Follow us on social media to get the latest product and support information.

