

Selecting and Applying DC Link Bus Capacitors for Inverter Applications

Sam G. Parler, Jr., P.E.
Cornell Dubilier

Abstract, aluminum electrolytic and DC film capacitors are widely used in all types of inverter power systems, from variable-speed drives to welders, UPS systems and inverters for renewable energy. This paper discusses the considerations involved in selecting the right type of bus capacitors for such power systems, mainly in terms of ripple current handling and low-impedance energy storage that maintains low ripple voltage. Examples of how to use Cornell Dubilier's web-based impedance modeling and lifetime modeling applets, whose calculation inputs include not only ambient temperature and airflow velocities but also separate mains and switching frequency components, are covered.

Introduction

In this paper, we will discuss how to go about choosing a capacitor technology (film or electrolytic) and several of the capacitor parameters, such as nominal capacitance, rated ripple current, and temperature, for power inverter applications of a few hundred watts and up.



Figure 1 shows some of Cornell Dubilier's DC Link capacitors for power inverters. Left photo features aluminum electrolytic capacitors of snap-in, plug-in, and screw-terminal varieties. Right photo shows screw-terminal, stud-terminal, and solder-leaded film capacitors.

In terms of source energy, we will discuss DC sources as well as rectified or chopped single-phase and three-phase AC, with or without PFC (power factor correction) and with or without bidirectional energy flow such as regenerative braking. For the inverter stage, we will be speaking in general terms of inverters requiring a low-impedance, capacitive energy input source, but we will not differentiate among specific inverter topologies and PWM (pulse width modulation) schemes, nor go into PWM theory such as the different conduction modes, harmonic injection techniques, THD calculation, etc.

Review of the basic power conversion scheme

In Figure 2 we see a general block diagram of a voltage-source inverter (VSI) that this paper will discuss. In general, the power flow is left-to-right unless power factor correction (PFC) or regenerative schemes are incorporated.

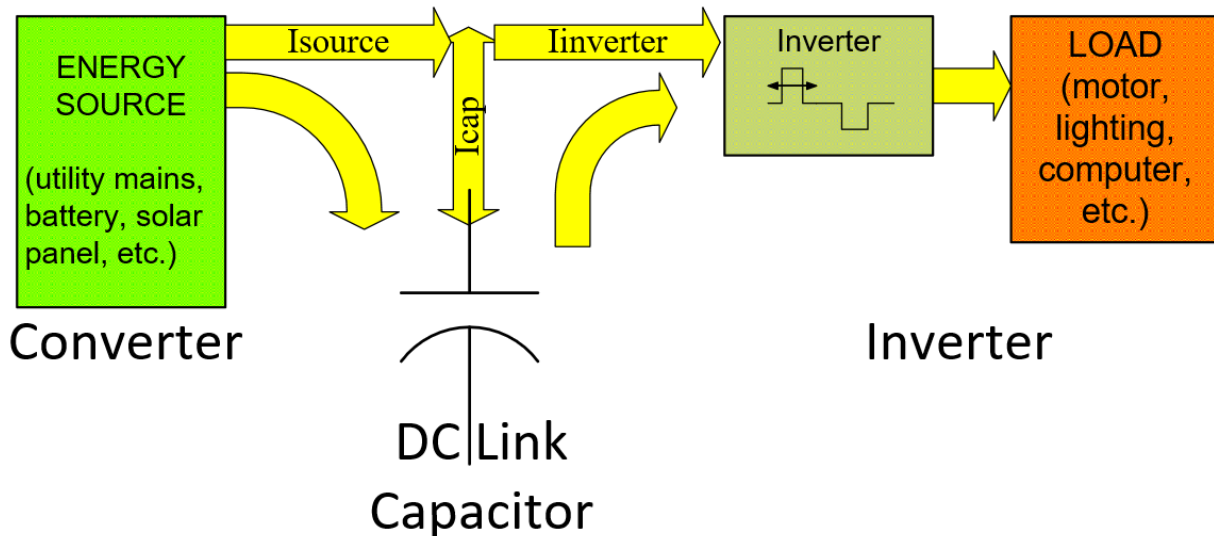

Figure 2: General block diagram of a voltage source inverter.

We may infer from Figure 2 that the DC link capacitor's AC ripple current I_{cap} arises from two main contributors: (1) the incoming current from the energy source and (2) the current drawn by the inverter. Capacitors cannot pass DC current; thus, DC current only flows from the source to the inverter, bypassing the capacitor. Power factor correction (PFC) in the converter and/or regenerative energy flow in certain topologies can complicate matters, but in all cases, instantaneous current is conserved at the three-current node of the DC link capacitor connection. Although some cancellation can occur between the AC components of the source current and the inverter current, it is usually a good approximation or at least conservative to estimate the capacitor's RMS ripple current as

$$I_{cap}^2(rms) \approx I_{source}^2(rms) + I_{inverter}^2(rms) \quad (1)$$

This is usually a good approximation because, as we will see later when we examine the frequency spectra, the converter stage usually has much lower frequency ripple current content than the inverter stage.

Therefore, let us first examine the converter stage by itself, and initially treat the inverter as a load with a fixed power or resistance. If the energy source is a battery or other pure-DC source, there will be no ripple current or ripple voltage on the DC link arising from this source, so we will only need to examine varying sources, particularly rectified or chopped AC mains.

Analysis of Energy Source Contributions to DC Link Ripple Current and Ripple Voltage

To facilitate the analysis and make the conclusions as general as possible, let us implement Per-Unit (PU) analysis based on the load power drawn by the inverter, assuming a conserved quantity *Power* and a mains frequency *f*. This basis is therefore equal to the ideal DC power delivered to a load resistor, so the base voltage is equal to the peak voltage at zero ripple voltage.

$$V_{base} = V_{dc}(Peak)$$

$$I_{base} = \frac{Power}{V_{base}}$$

$$R_{base} = \frac{V_{base}^2}{Power}$$

$$L_{base} = \frac{V_{base}^2}{2\pi f Power}$$

$$C_{base} = \frac{Power}{2\pi f V_{base}^2}$$

Let us first examine rectified single-phase 50 Hz mains with ideal diodes. Such “linear” power supply schemes can produce very high ripple current in the DC link capacitor, as it serves as a filter capacitor in this role. The current pulses charging the capacitor when the diode(s) are forward-biased are generally much briefer than the time the capacitor is discharging into the load. Due to the principle of Charge Conservation in a capacitor, these pulses are therefore quite a bit higher in amplitude than the load current. This usually results in the capacitor’s RMS ripple current being greater than the DC current delivered to the load. Generally, some amount of line inductance is added, or transformer leakage inductance is considered or recognized, for valid modeling and/or implementation.

Figure 3 shows a full-wave bridge schematic which we will first analyze on a per-unit basis for the capacitor’s AC RMS ripple current and peak-to-peak ripple voltage.

Most power supply designers want a peak-to-peak ripple voltage of less than 5%, and usually limit line inductance to about 5% per-unit. What we see from the Spice analysis results summarized in Figure 4 is that of a single-phase full-wave bridge analysis of the circuit of Figure 3. In order to accomplish these objectives, a lot of capacitance is needed, on the order of 40 PU or more. Figure 5 shows that as long as some line inductance such as 1% per-unit is incorporated, the RMS ripple current isn’t very sensitive to the level of capacitance. In Figure 6 we show the frequency content of the capacitor ripple current. Nearly zero at DC (0 Hz) as it should be, then only a few components at 2, 4, and 6 times the line frequency.

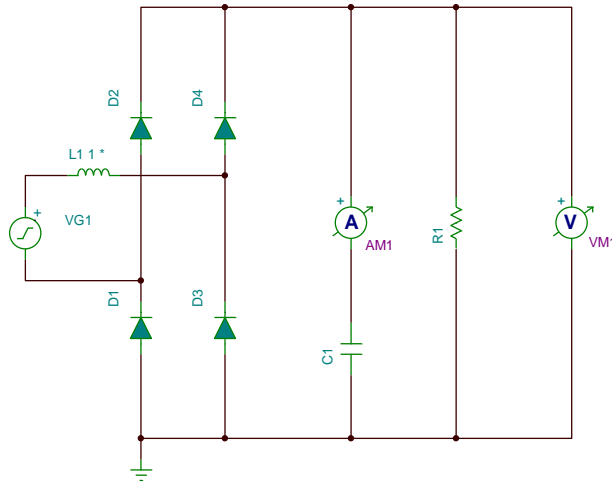

Figure 3: Full-wave bridge with line inductor, filter capacitor, and resistive load.

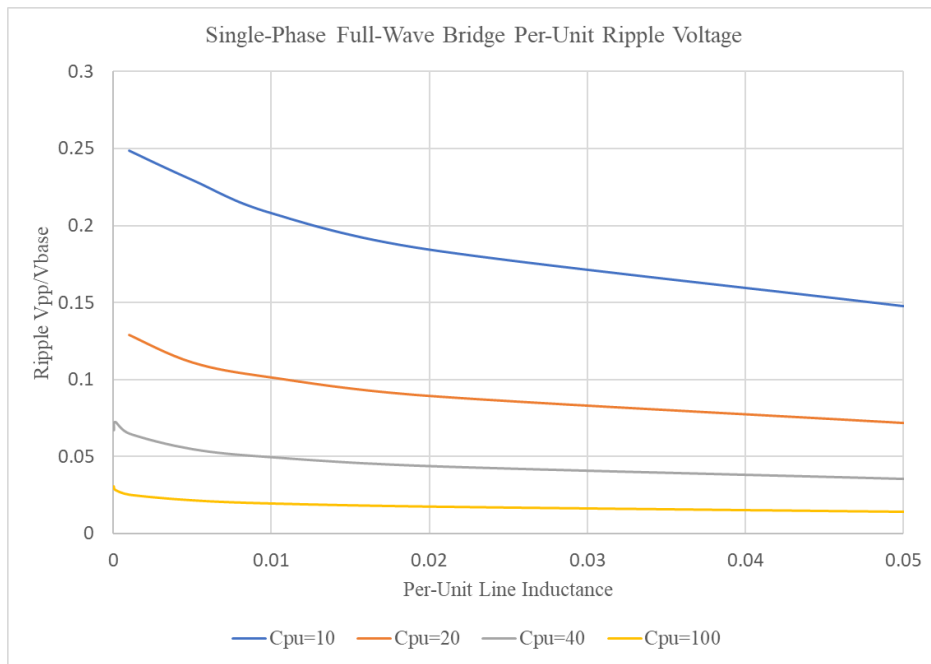

Figure 4: Per-unit analysis of percent peak-to-peak ripple voltage versus line inductance for four values of filter capacitance.

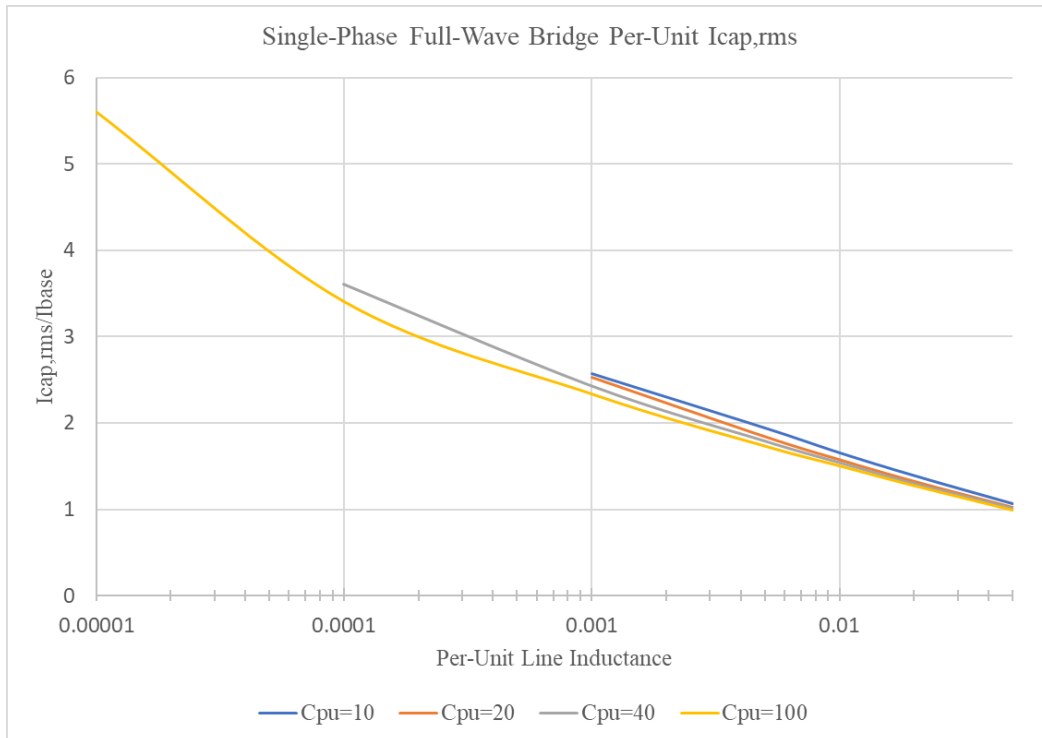

Figure 5: Per-unit analysis of RMS ripple current through the filter capacitor versus line inductance for four values of filter capacitance.

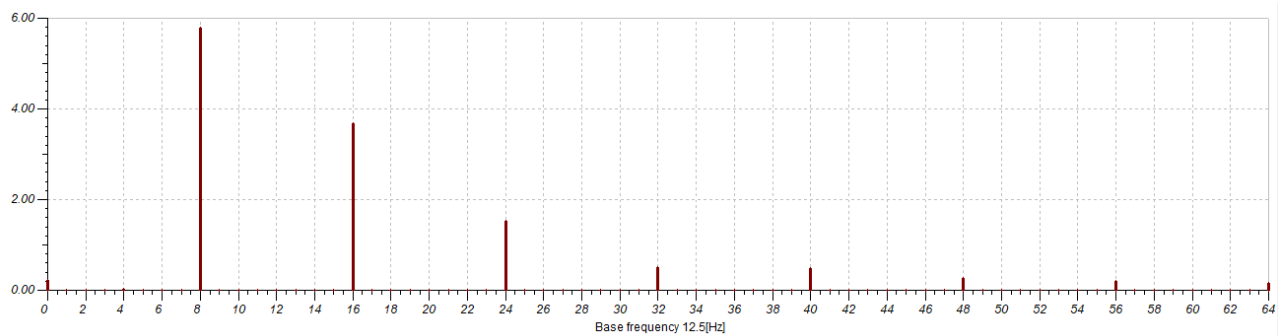

Figure 6: Ripple current magnitude frequency spectrum for a full-wave bridge with 50 Hz mains. The abscissas are multiples of 12.5 Hz, and thus the energy bands are at all even-integer multiples of the mains frequency, decaying rapidly.

Figure 7 shows a half-wave bridge schematic, which is even more demanding on a per-unit basis than was the full-wave bridge, as far as the capacitor's AC RMS ripple current and peak-to-peak ripple voltage are concerned. The analysis summarized in Figure 8 shows that to achieve a peak-to-peak ripple voltage of less than 5%, a capacitance on the order of 100 PU or more is required. It's probably cheaper to just add three diodes! Figure 9 shows that more line inductance such as several percent per-unit is needed to lower the RMS ripple current to a modest level. In Figure 10 we see that the frequency content of the capacitor ripple current is nearly zero at DC (0 Hz) as it must be,

then only a few components at half the frequencies of the full-wave bridge; thus at 1, 2, and 3 times the line frequency, rolling off rapidly.

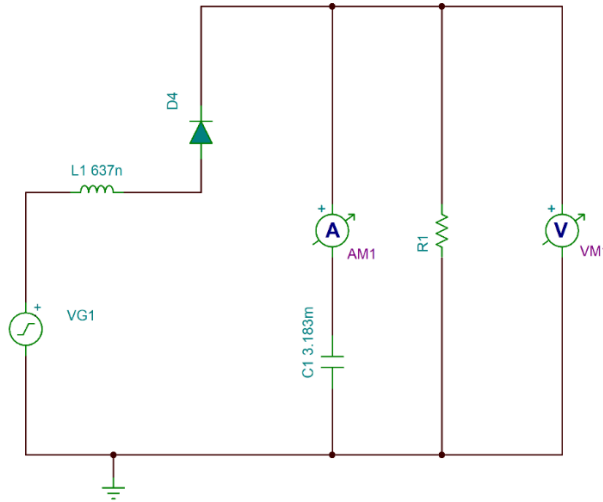

Figure 7: Half-wave bridge with line inductor, filter capacitor, and resistive load.

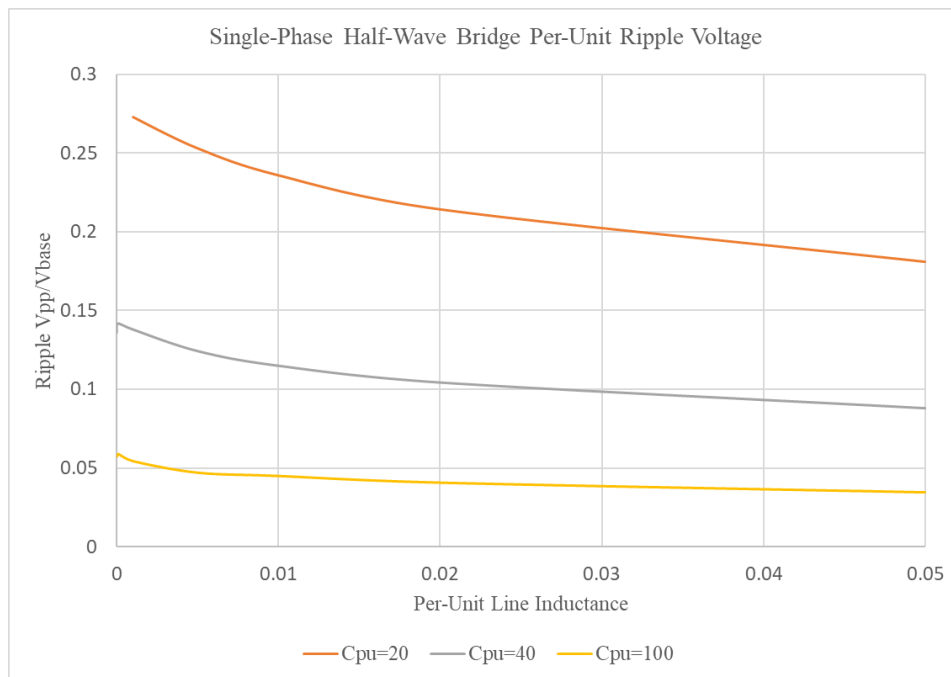

Figure 8: Per-unit analysis of percent peak-to-peak ripple voltage versus line inductance for four values of filter capacitance.

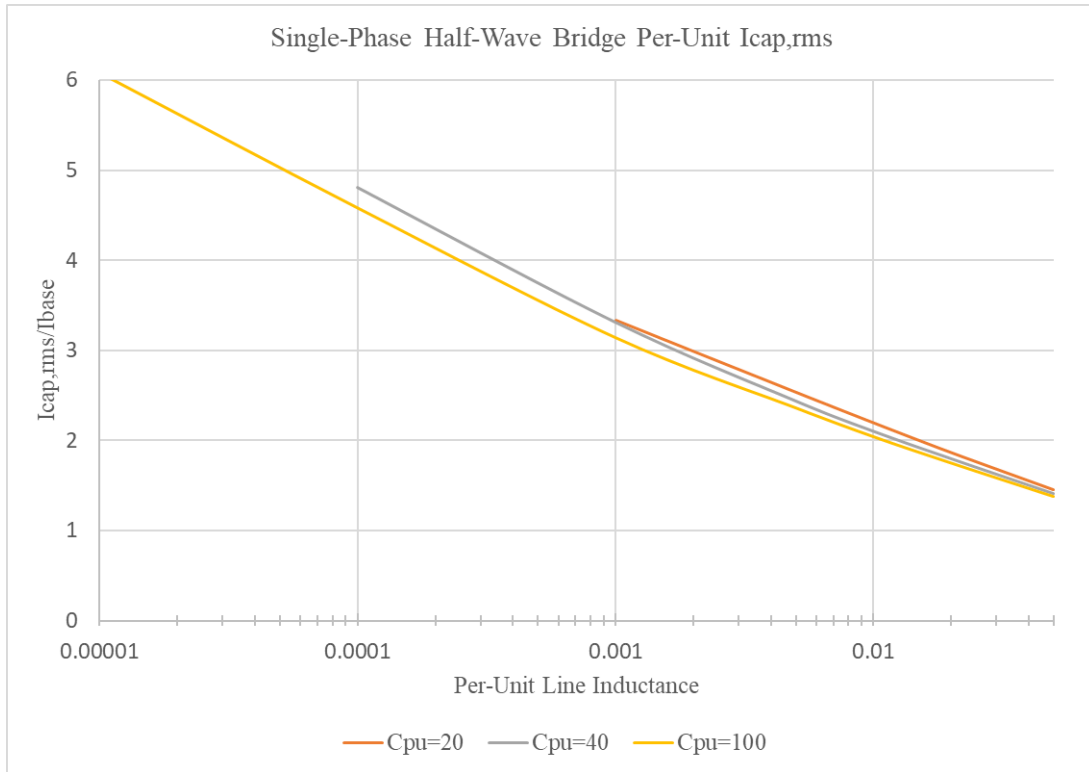

Figure 9: Per-unit analysis of RMS ripple current through the filter capacitor versus line inductance for four values of filter capacitance.

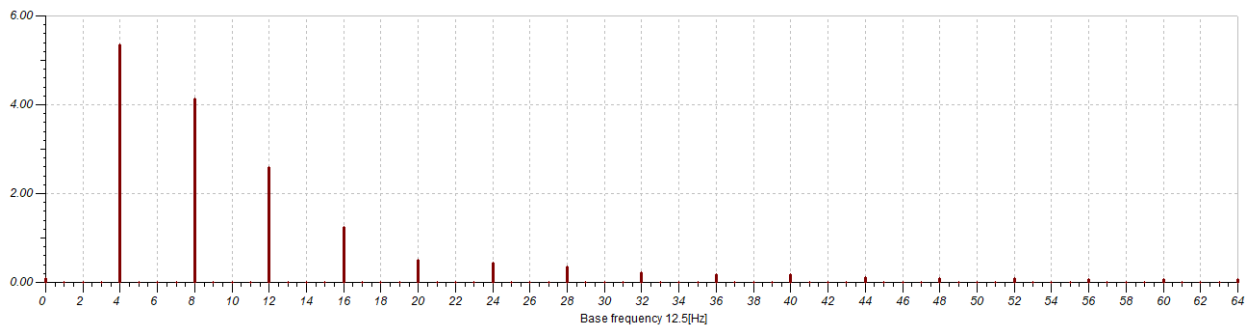

Figure 10: Ripple current magnitude frequency spectrum for a half-wave bridge with 50 Hz mains. The abscissas are multiples of 12.5 Hz, and thus the energy bands are at all integer multiples of the mains frequency, decaying rapidly.

Next, we move on in our converter-stage analysis from single-phase rectifiers to three-phase, six-diode rectifiers, very common input for our DC Link film and electrolytic capacitors. See Figure 11. The per-unit inductance is in each leg of the three-phase lines. We are going to keep the same base units as for single phase so that the comparisons will be on the nominal power delivered to the resistive load at its nominal peak voltage. Such rectified mains configuration without L and C

would have a ripple voltage of no more than $1-\sqrt{3}/2 \approx 0.134$ per-unit, as this is the maximum droop from the peaks of the three 120° -phase-shifted, overlapping sinusoidal mains-voltage rectified waveforms.

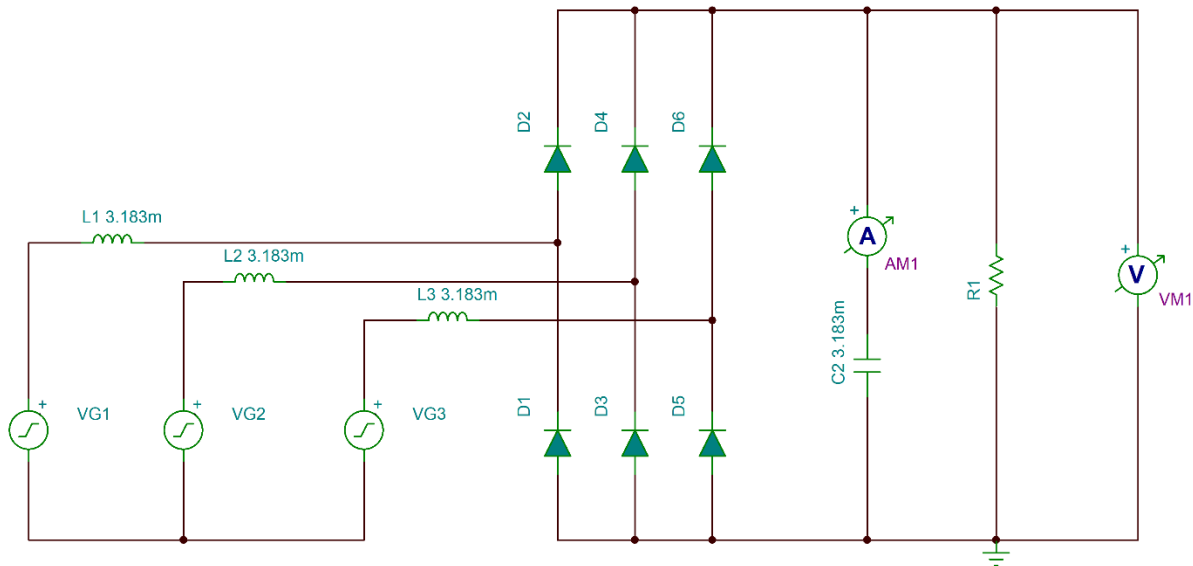

Figure 11: Three-phase, six-diode rectified bridge with line inductor, filter capacitor, and resistive load.

From the results summarized in Figure 12, we observe that with only 1.5% line inductance, we can achieve less than 5% ripple voltage with a much smaller capacitance of only 4 per-unit, as compared to 40 for single-phase full-wave bridge. However, even for the three-phase, six-diode rectifier, going below $C_{pu} = 4$ isn't advisable for normal values of L_{pu} as seen in the enormous ripple voltage that occurs at 1 and 2 PU. This is due to the LC ringing.

In Figure 13 we see that the capacitor ripple current per-unit is less than half that of the single-phase full-wave bridge rectifier discussed earlier.

As we will discuss later, capacitor ESR decreases with increasing frequency. Instead of ripple current components being at very small multiples of the utility mains frequency, we see in Figure 14 that the multiples are now at 6, 12, and 18 times the mains frequency.

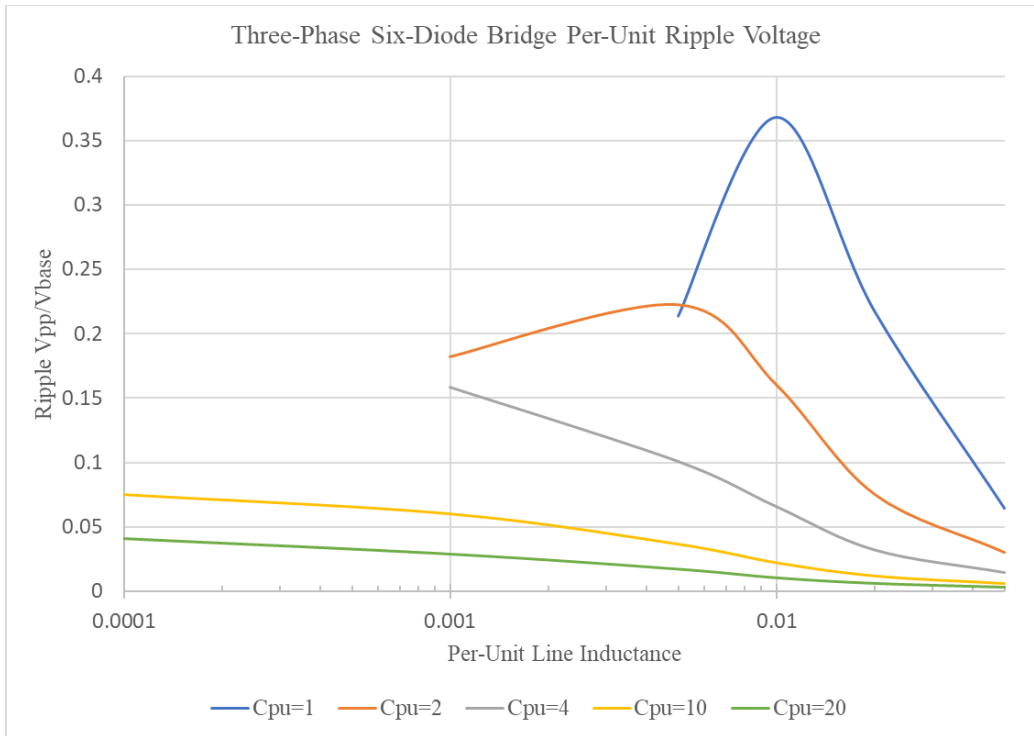

Figure 12: Per-unit analysis of percent peak-to-peak ripple voltage versus line inductance for five values of filter capacitance. Resonant behavior is seen near $L_{pu}C_{pu} \approx 0.01$.



Figure 13: Per-unit analysis of RMS ripple current through the filter capacitor versus line inductance for five values of filter capacitance.

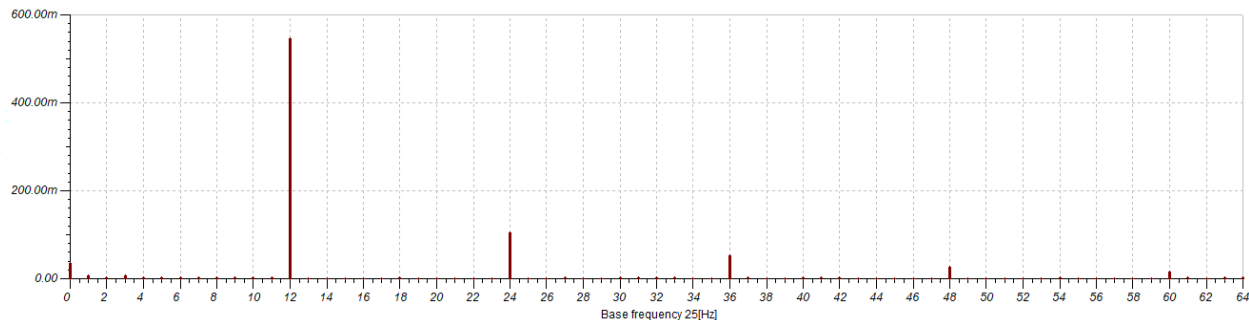

Figure 14: Ripple current magnitude frequency spectrum for three-phase, six-diode rectified bridge with 50 Hz mains. The abscissas are multiples of 25 Hz, and thus the energy bands are at all integer multiples of six times the 50 Hz mains frequency, decaying very rapidly.

Analysis of Inverter Contributions to DC Link Ripple Current and Ripple Voltage

If we increase our level of abstraction high enough, we recognize that the rectified-mains analysis in the previous section reveals this energy source to be a sequence of current pulses applied to the capacitor. This suggests that a similar approach may be applied to the analysis of the inverter input current, which draws a sequence of pulses from the DC link capacitor. Both of these sets of pulses will cause voltage ripple as well as ripple current and its attendant heating.

As far as the effect on capacitor ripple current and ripple voltage, the main difference between these two distinct sets of pulses, energy source versus inverter sink, is the range of frequencies involved. Typically, the rectified mains and its harmonics are less than 2 kHz, while the inverter switching frequency and its harmonics are usually above 2 kHz.

No rule states that the energy source must be diode rectified. In fact, it could be chopped up with IGBT's or SiC switches similarly or differently from the inverter scheme. Circuits that accomplish power factor correction, bi-directional energy flow (e.g. regenerative braking), etc. generally operate in this manner.

Ultimately the overall analysis of the capacitor ripple current and voltage will involve superposition of the current flows at its connection node.

In general, the inverter stage uses solid-state switches such as IGBT's or SiC devices to chop up its DC voltage input to create a digital looking (multilevel) or an even simpler binary (two-level) output voltage waveform, depending upon how many "levels" (discrete voltage values, varying from two to six or more levels) the PWM topology incorporates.

For this reason, a long time ago these were referred to as "choppers," and sometimes still are, especially for DC-DC converters, but more formally they are called PWM's (pulse-width modulators).

The unfiltered PWM output voltage is never a true sine wave, but when driving an inductive load such as a motor, the current will tend to be proportional to the time-integral of the PWM voltage waveform, whose modulation scheme is designed so that the webers (volt-seconds) of these pulses will produce approximately a sinusoidal current, since for an inductor L , we have a current $i = \int v dt/L$. And for applications such as a UPS, requiring something close to a sinusoidal voltage, an LC or ferro-resonant filter can be used after the PWM stage, effectively integrating and low-pass-filtering the voltage waveform.

As will be discussed later, the PWM control/modulation scheme can affect capacitor heating, but usually, the primary goals of the power supply designer are to meet (1) efficiency goals, (2) overall cost, size, and reliability constraints and (3) total harmonic distortion limits such as 5%, and sometimes input power factor limits. So minimizing capacitor losses isn't always the highest priority for the power supply design engineer. Still, it is good to investigate and quantify the relative impact of various factors affecting the capacitor stress.

General Voltage Source Inverter

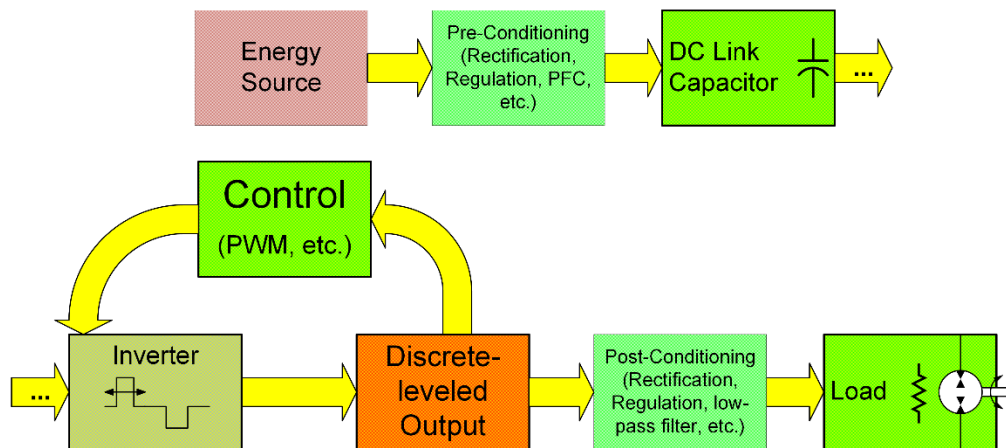
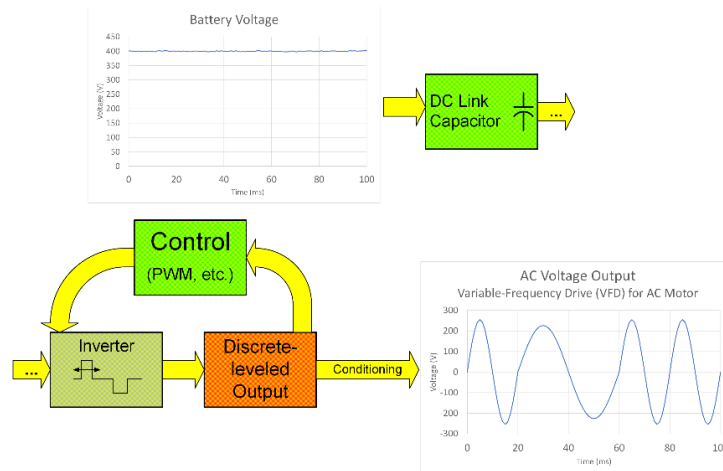
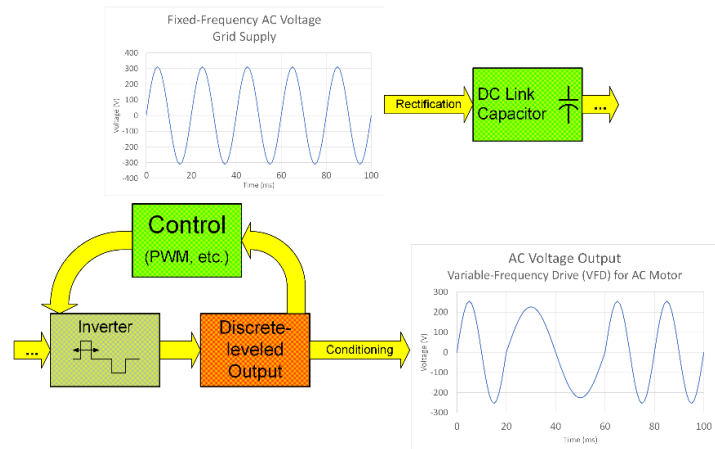

Figure 15: General block diagram of a voltage source inverter. The top row is the Converter and the DC Link. The bottom row is the Inverter stage.

Electric Vehicle Motor Drive Inverter



VFD AC Motor Drive Inverter



Wind Turbine Inverter

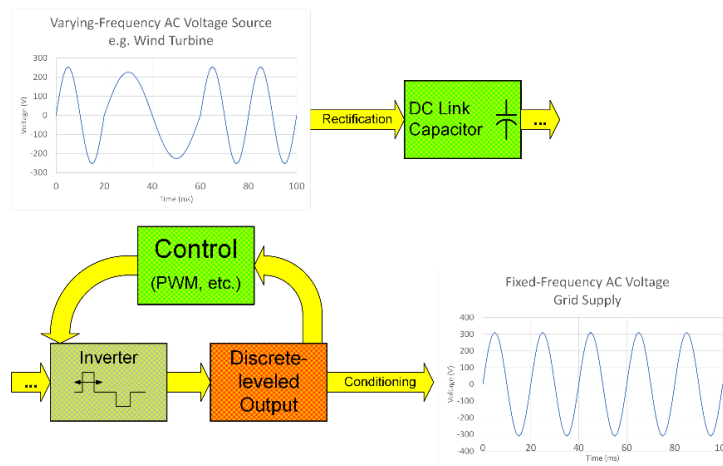

Figure 16: Three example application topologies. The topological variations arise from differences in the nature of the energy supply and demand.

There are many inverter PWM switching and control schemes. Some are carrier based and some are not. We will consider a somewhat simplified scheme to demonstrate a typical inverter input effect on the DC link capacitor ripple current and ripple voltage.

The scheme we will consider is carrier-based sinusoidal PWM, also known as SPWM. The sinusoidal waveform is a reference signal for the desired output current such as motor drive current and frequency while the triangle wave is a fixed-frequency carrier with a repetition frequency equal to the inverter switching frequency. This is not Space Vector PWM (SVPWM), yet the capacitor ripple-current energy and spectrum can be very similar.

The amplitude of the sinusoidal reference signal as a factor of the amplitude of the reference signal is known as the modulation index, m , and three ranges of m value are seen in Figure 17. The instantaneous values of these two signals are compared, and a binary PWM signal is thereby generated, as seen in blue. To people unfamiliar with PWM power supplies, it can be amazing that PWM waveforms such as the ones shown in blue could ever result in anything close to a sinusoidal output current (motor load), much less a sinusoidal output voltage (UPS).

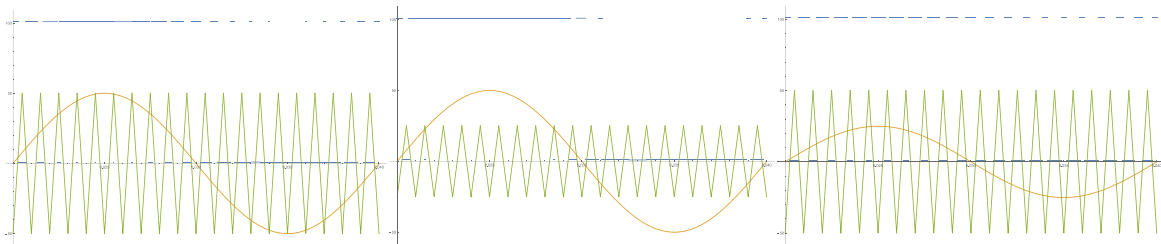

Figure 17: Examples of carrier-based sinusoidal PWM. The sinusoidal waveform is a reference signal for the desired output current while the triangle wave is the carrier with a repetition frequency equal to the inverter switching frequency. The blue pulsed waveform is the PWM output signal. Left: Modulation index $m=1$. Center, overmodulation $m > 1$. Right, under modulation $m < 1$.

An extension of the previously considered three-phase, six-diode rectified 50 Hz mains is seen in Figure 18. Instead of a fix-resistance load, we have placed an inductive load with a series resistor and are driving this load with a mathematically generated SPWM source voltage. To make it easier to view the waveforms, we are using a fairly low carrier frequency of 1 kHz, and driving a single-phase motor load (simulated by the inductor) at a frequency of 40 Hz.

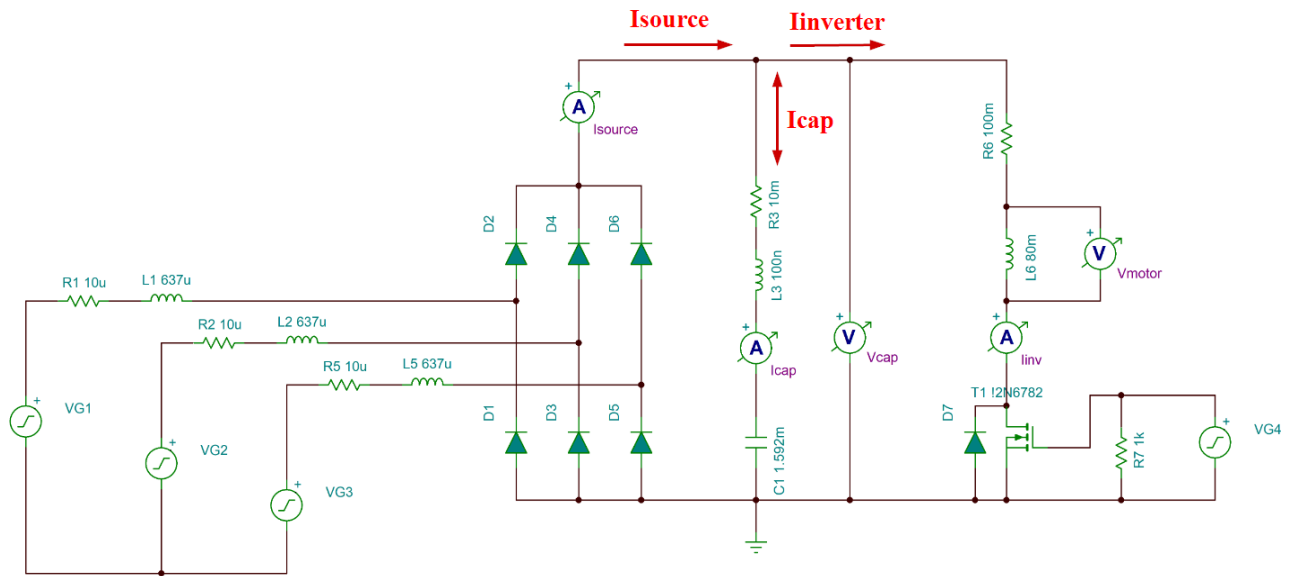

Figure 18: Current flow diagram of a voltage source inverter at the DC Link Capacitor node. I_{SOURCE} is current from the source energy such as a battery or— in this case— rectified mains, while $I_{INVERTER}$ is the pulsed DC current into the inverter. I_{CAP} is the capacitor's AC ripple current.

Figures 19 and 20 show the time-domain waveforms and details. It appears that the capacitor may need to be beefed up, as the current pulses being drawn from the energy source are very high in amplitude.

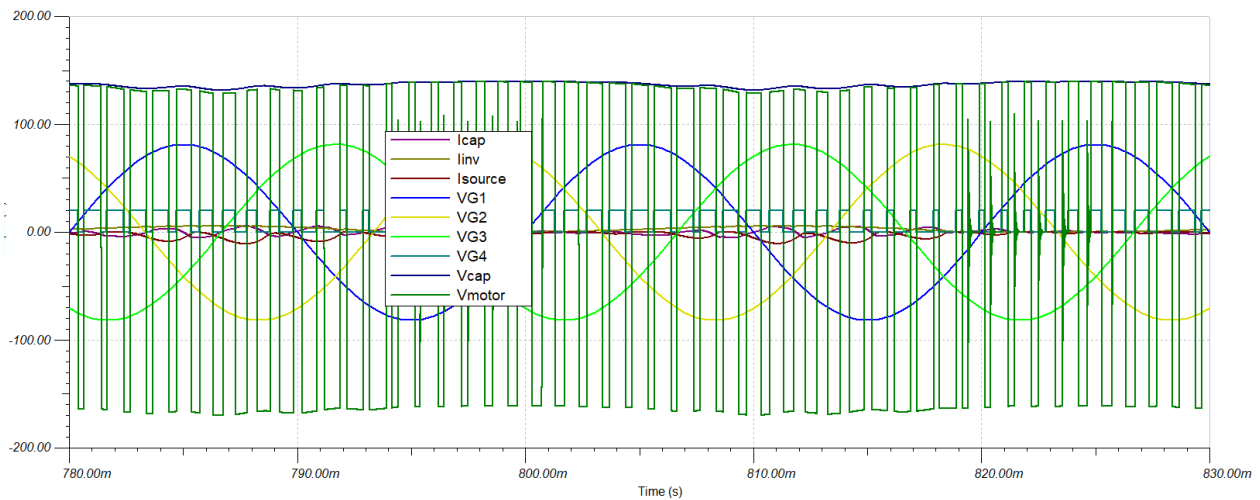

Figure 19: All voltages and currents from the simulation of Figure 18. Total time scale is 50 milliseconds, twice the 40 Hz motor drive period and 2.5 times the 50 Hz mains period.

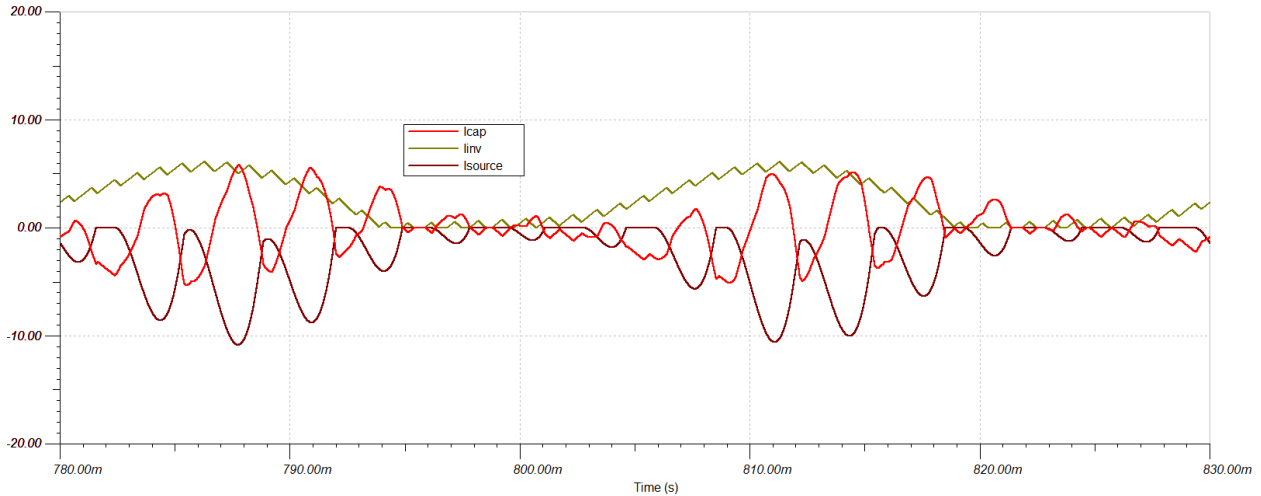
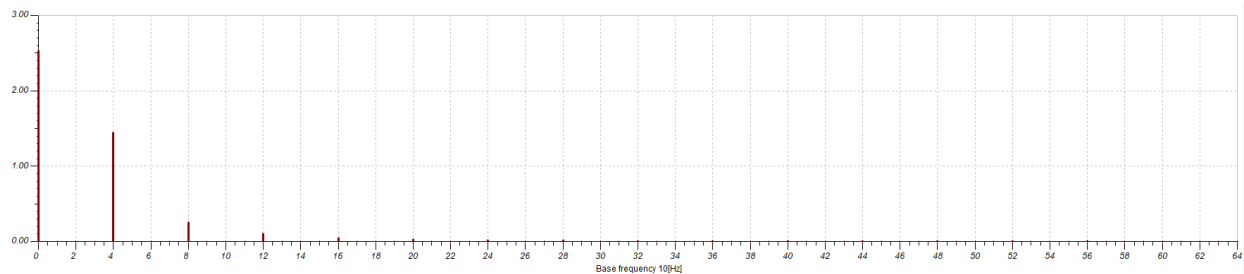

Figure 20: Only the currents of the source, capacitor, and inverter.

The frequency spectra of the inverter input current and of the capacitor ripple current are seen in Figure 21. First note that the spectral magnitude of the inverter input current shows a large DC (0 Hz) component as well as 40, 80, and slight 120 Hz amplitudes, which are multiples of the 40 Hz single-phase motor drive output frequency. However, there is no presence of the 300 Hz rectified mains current component. On the other hand, the capacitor ripple current shows no DC component but possesses a 40 Hz output current and its multiples, along with a large 300 Hz component due to the rectified three-phase 50 Hz mains.

Also, note in the capacitor's ripple current spectrum, the two sidebands straddling the 300 Hz component; these are at 300 ± 40 Hz = 260 and 340 Hz, typical of the modulated interaction between the mains input and the motor drive output. Note that the existence of such modulated sidebands suggests the possibility that inverter schemes with multiple switching, rectification, and AC-output frequencies can potentially produce ripple current components at frequencies below any of the fundamental frequencies associated with these components, thereby potentially increasing capacitor losses.

The 1 kHz switching frequency components were not able to be analyzed accurately in the Spice modeling software being used. A 1 kHz component did appear, but also a little bit of DC current showed up, indicating perhaps insufficient selectivity within its frequency-analysis algorithm.



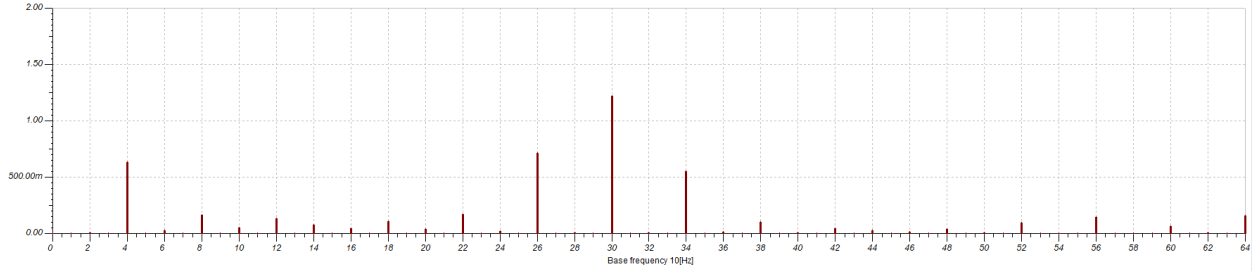

Figure 21: Ripple current spectra, multiples of 10 Hz. Top: inverter spectral magnitude showing large DC (0 Hz) component as well as 40, 80, and slight 120 Hz amplitudes, which are multiples of the 40 Hz single-phase motor drive output frequency. Bottom: Capacitor ripple current, showing no DC component as well as 40 Hz output current and its multiples, along with a large 300 Hz component due to the rectified three-phase 50 Hz mains.

Capacitor ESR can be modeled approximately as having two terms, a first term R_o that doesn't vary with frequency and a second term R_d which arises from the dielectric loss angle. The series resistance associated with dielectric loss varies approximately in direct proportion to $1/f$ over an extremely broad frequency range.

$$ESR = R_o + R_d(f) = R_o + DX_c = R_o + \frac{D}{2\pi fC} \quad (2)$$

The second term is equal to the dissipation factor D multiplied by the capacitive reactance. Thus, ESR overall tends to decrease monotonically with increasing frequency. The dielectric resistance is directly proportional to D and inversely proportional to the product of frequency and capacitance.

Thus for a given RMS component magnitude, the low-frequency components of ripple current cause more heating than the high-frequency components.

Spectral Analysis and Joule Heating Effects of Pulse Rep Rate, Shape, and Spacing

Let us state and then examine the following hypothesis in consideration of the current drawn by the inverter from the capacitor: **For a given AC RMS value and pulse duty, the dielectric loss component of the DC link capacitor is a strong function of the inverter switching frequency and current pulse spacing, but not of the exact pulse shape.**

To evaluate the hypothesis in the previous paragraph, we will examine 5 pulse-current waveforms, each occurring at a repetition frequency of 1 kHz (i.e. a 1 ms period) and having an RMS value of 33.3 amps RMS.

First, in Figure 22 we have a $100\text{-amp} \times 100\ \mu\text{s}$ pulse. It has a large fundamental component at the 1 kHz rep rate, so because capacitor ESR has a $1/f$ term, the dielectric loss would be half at 2 kHz as it would at 1 kHz. This proves the first part of the hypothesis, that the dielectric loss is a strong function of the switching frequency. For a $130\ \mu\text{F}$ capacitor, a value of dielectric loss tangent of $D = 2\%$ yields a power loss of 11.9 watts for this waveform.

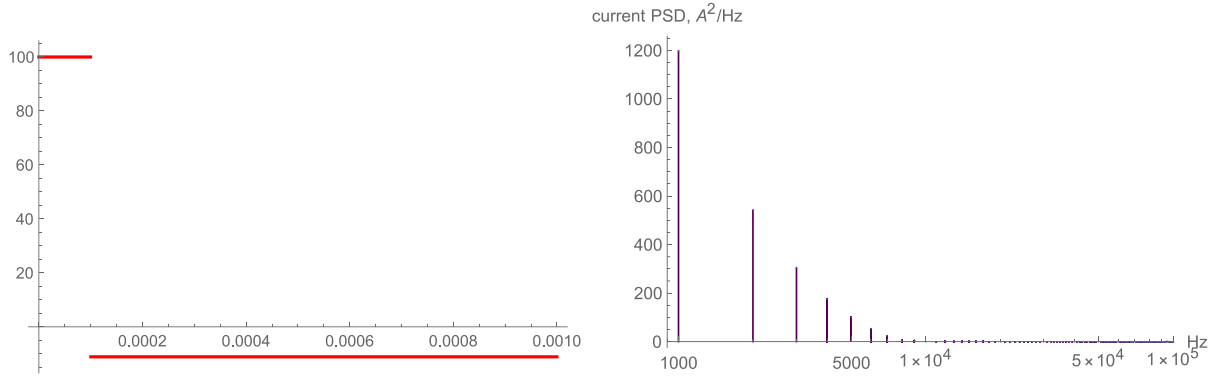

Figure 22: 33.3 amps RMS \times 100 μ s flat-top pulse occurring at 1 kHz rep rate, and its spectral-magnitude components. Reference power loss is 11.9 watts.

Next, we will keep the same RMS value, repetition frequency, and pulse width, but change the pulse shape from flat-top to sloped to sawtooth, i.e. from completely flat-topped to progressively more sloped. We see these time and frequency domain plots in Figures 23 and 24. Different as the time-domain appearances are, the spectra are similar in appearance, and the reference capacitor losses for the three cases of Figures 22, 23, and 24 are, respectively, 11.9, 11.7, and 10.1 watts. This proves the part of the hypothesis which posits that the dielectric loss is not a strong function of the exact pulse shape, for a given RMS value and pulse duty.

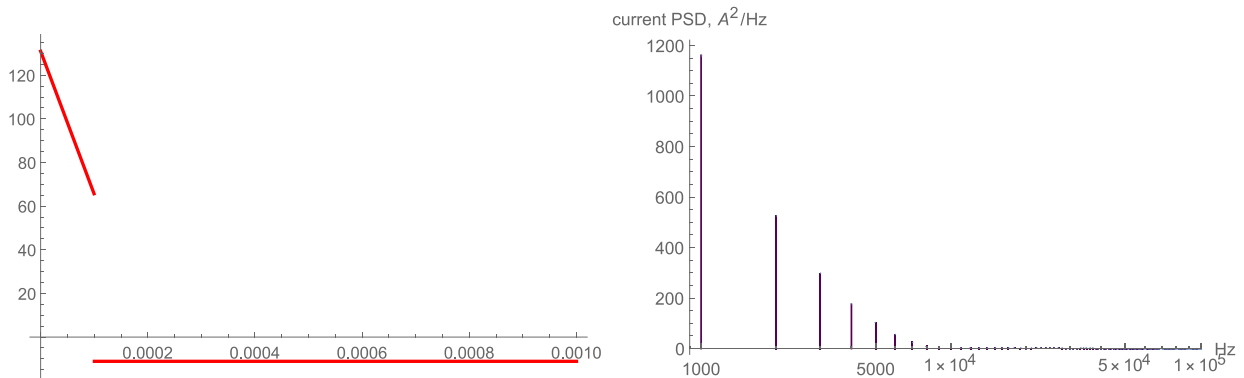

Figure 23: 33.3 amps RMS \times 100 μ s slope-top pulse occurring at 1 kHz rep rate, and its spectral-magnitude components. Reference power loss is 11.7 watts.

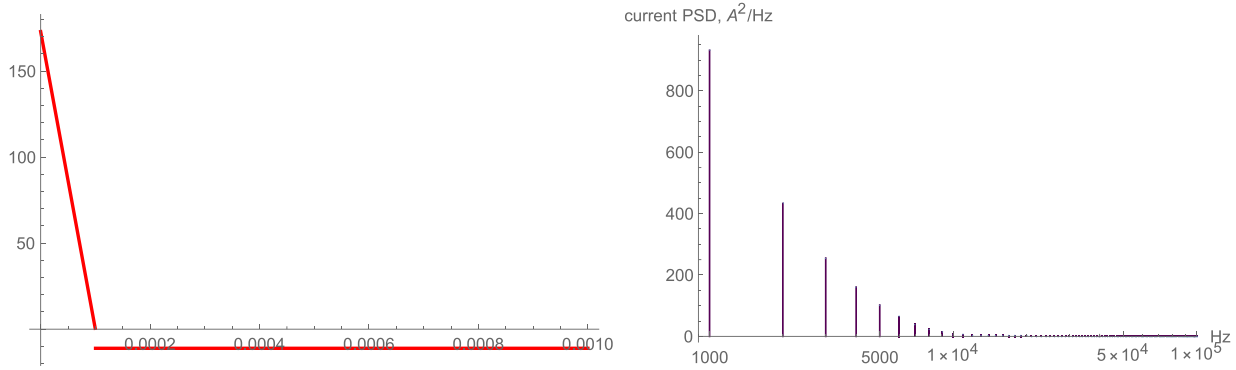

Figure 24: 33.3 amps RMS \times 100 μ s sawtooth pulse occurring at 1 kHz rep rate, and its spectral-magnitude components. Reference power loss is 10.1 watts.

Finally, we will look at the spectrum and dielectric heating from a 100 μ s wide flat-top pulse with an inverted twin pulse in two configurations: first, in close proximity and then in distant separation. Figure 25 shows that the contiguous-pulse arrangement depresses the 1 kHz fundamental harmonic which results in low dielectric heating of the reference capacitor of only 7.46 watts. Figure 26 shows equal/maximum inter-pulse spacing within the 1 ms period, resulting in odd harmonics only, with a very pronounced, dielectric-loss-inducing fundamental. At 14.43 watts, the power loss in the reference capacitor is nearly twice that of the contiguous pulse pair. This proves the part of the hypothesis which states that the dielectric loss component of the DC link capacitor is a strong function of the inverter current pulse spacing.

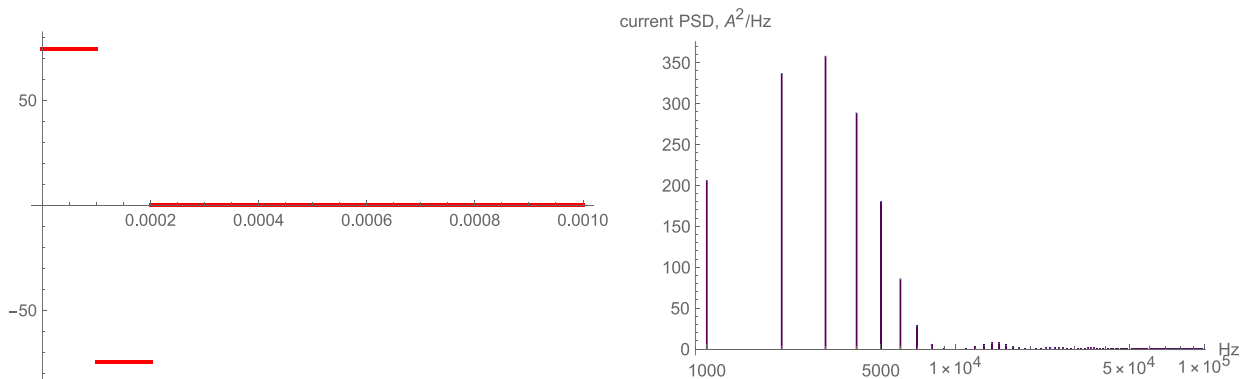

Figure 25: 33.3 amps RMS \times contiguous bipolar dual 100 μ s rectangular pulse occurring at 1 kHz rep rate, and its spectral-magnitude components. Reference power loss is 7.46 watts.

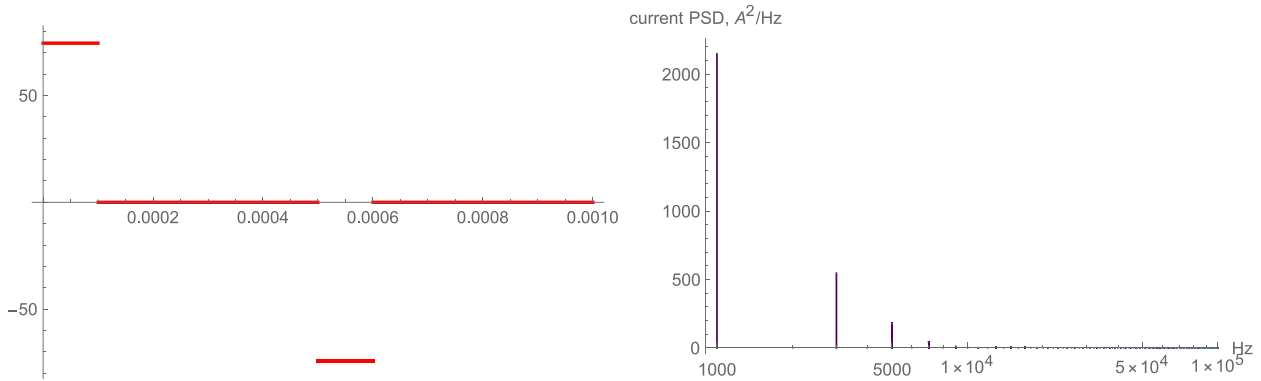

Figure 26: 33.3 amps RMS, maximally-separated bipolar dual 100 μ s rectangular pulse occurring at 1 kHz rep rate, and its spectral-magnitude components. Reference power loss is 14.43 watts, nearly twice the power loss of the same pulses when contiguous as in the previous figure.

General expression for DC Link ripple current for PWM inverter with balanced 3-phase output

For the case of a PWM inverter with balanced 3-phase output, there is an expression that gives a good estimate of the capacitor ripple current in terms of the previously discussed modulation index m as well as the load's phase current, and is generally accurate within several percent for most PWM inverter modulation schemes with three-phase AC outputs. This expression is attributed to Kolar *et al* and is equation (3) below. Note that it is the ratio of the capacitor RMS current to the line output current from the inverter to the load. Note also that it is independent of the inverter switching frequency.

$$I_{CAP,rms} \equiv I_{L,rms} \sqrt{2m \left[\frac{\sqrt{3}}{4\pi} + \left(\frac{\sqrt{3}}{\pi} - \frac{9m}{16} \right) \cos^2(\varphi) \right]} \quad (3)$$

This expression is graphed in Figure 27 for a wide range of modulation indexes and load phase angles.

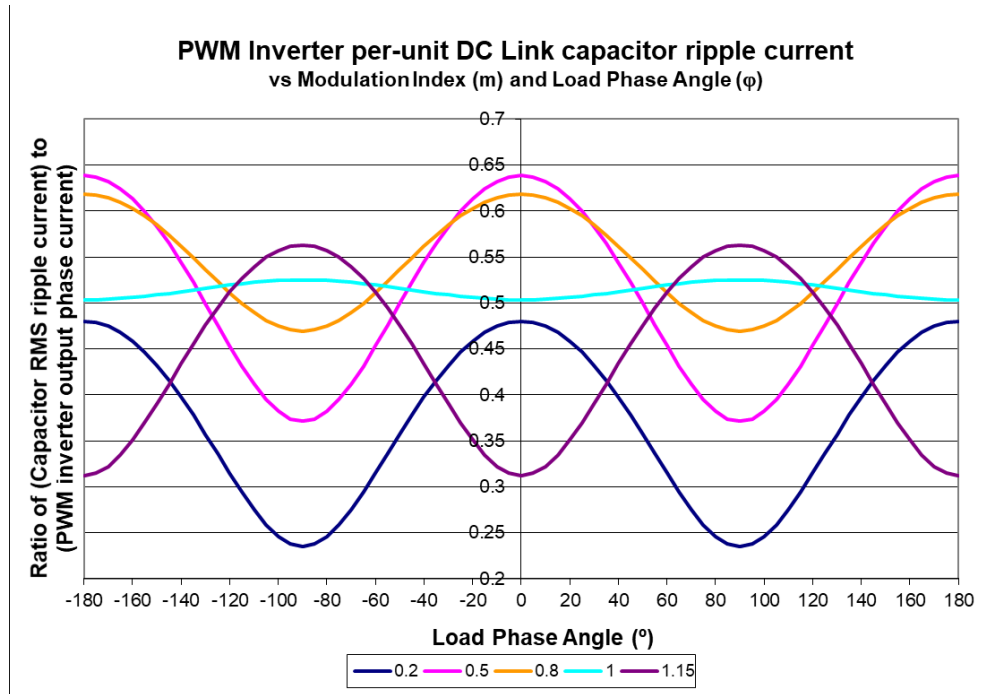

Figure 27: Three-phase inverter capacitor ripple current as a function of m and ϕ .

Resources for selecting the right capacitor

From the discussion and analysis earlier in this paper, it appears that for most inverter applications the ripple voltage can be estimated by using a per-unit analysis to pick a range of possible capacitances versus the design’s operating voltage, power level, and frequency. However, if there are any ride-through requirements, the capacitance level may need to be further increased.

The capacitor voltage rating needs to exceed the worst-case peak bus voltage, such as under “high-line” mains conditions or maximum solar panel output voltage, etc. Low-ESR aluminum electrolytic capacitors are rated only up to 500 VDC, so may need to be connected in series with balancing resistors. See our application guide for more information on series connection and balancing resistors. Film capacitors are rated to much higher voltages than aluminum electrolytic capacitors and generally do not require a series connection. Aluminum electrolytic capacitors are less expensive per unit of nameplate energy, but they don’t handle as much ripple current per unit of stored energy, so the ripple current handling needs to be investigated as outlined next.

Example of 3-phase, 10 horsepower motor drive

For three-phase inverters at any DC bus voltage, for films and electrolytics, respectively, a rule of thumb is that about 5 and 50 millicoulombs of capacitor nameplate CV rating will be required per amp of ripple current. For example, on a 10 horsepower motor drive with a 700 VDC bus, if you calculate a capacitor ripple current of 7 amps RMS, that would come out to be a 50 μF film or a 500 μF aluminum electrolytic capacitor. The probable embodiment would be a single 50 μF

800 VDC film vs two 1,000 μF 400V aluminum electrolytic capacitors in series. For single-phase or high-impedance input, or large ride-through requirements, these rules of thumb may need to be tripled or more.

If we want to examine the per-unit capacitance of the above, we can rearrange our earlier base equations, but we shouldn't use the capacitor voltage and ripple current but rather the motor line voltage and full-load current. Let us suppose that the 10 HP motor is driven with 460V and 12.4 amps. Using a three-phase base power of $\sqrt{3}V_{\text{LINE}}I_{\text{LINE}} = 9880 \text{ VA}$ results in per-unit capacitance values of $C_{\text{pu}}=3.36$ for the electrolytic and 0.336 for the film.

$$C_{\text{base}} = \frac{S_{\text{base}(3\phi)}}{2\pi f V_{\text{base}}^2} = 149 \mu\text{F} \quad (4)$$

Since capacitor lifetime and failure rate are exponential functions of temperature and thus of ripple current, the ripple current stress on the DC link capacitor is critical and needs to be managed carefully and conservatively. Assuming that the minimum capacitance and voltage rating have been chosen as discussed above, the best way to proceed in selecting candidate capacitors is based upon ripple current handling. So the first step is to calculate the total ripple current.

A rule of thumb regarding ripple current handling is to choose a capacitor whose rated ripple current under high-temperature, short-duration life test conditions is in the ballpark of the total calculated DC link ripple current for the application. The rated "load test" current often is accompanied by tables of so-called "ripple multipliers" such as for higher application frequency or lower ambient temperature and derated DC voltage. But be aware that applying these multipliers to the rated ripple current shortens the capacitor lifetime back to its nominal test duration, which is typically only 5 to 10 thousand hours. So, it's a better first approximation to start with candidates whose nominal ripple current rating is close to the actual application ripple current, at least until you can perform thermal and lifetime calculations.

Proceed with the thermal analysis by partitioning the ripple current into two frequency bins per equation (1): the lower frequency at the appropriate multiple of the mains frequency (depending upon the number of phases and upon what rectification or chopping scheme is being used) and the higher frequency at the inverter switching frequency per equation (3) if a balanced 3-phase PWM inverter scheme is applicable. Otherwise, the inverter input current and DC link current needs to be calculated or modeled.

This method of ripple current analysis should be inherently somewhat conservative for two reasons. First, because there can be some cancellation between $I_{\text{SOURCE, AC, RMS}}$, and $I_{\text{INVERTER, AC, RMS}}$, $I_{\text{CAP, RMS}}$ may not be fully equal to the RSS (root sum of squares) value of these two ripple components. The second source of conservatism is that the capacitor ESR generally decreases with increasing frequency, due to its dielectric loss component being proportional to the capacitive reactance. Since this analysis method proposes that the fundamental components of these two contributions be used in the thermal analysis, the ESR estimate should be slightly higher than in actual practice.

Now that the voltage rating, minimum capacitance, and the two sets of ripple currents and their frequencies are known, it is appropriate to begin some thermal and lifetime estimation exercises.

There are many resources available at the Cornell Dubilier website, including other technical papers that may be helpful. Our application guides include detailed guides for aluminum electrolytic and power film capacitors and are located at <https://www.cde.com/tech-center/application-guides> Our engineering technical papers may be found at <https://www.cde.com/tech-center/engineering-technical-papers> Also, there are interactive, combination core-temperature and lifetime calculators and even Spice model code generators for many of our capacitors. The landing page for these tools is <https://www.cde.com/tech-center/life-temperature-calculators>

Our core-temperature calculators facilitate the analysis method outlined in this paper, as they provide ripple current input fields for two frequencies. It is permissible to use only one of these two fields, but for inverter applications, it is most realistic to enter the information for both frequencies. Returning to the 10-horsepower motor drive example several paragraphs back, assume the 7 amps of ripple current comprises 4.00 amps at 300 Hz and 5.74 amps at the inverter switching frequency of 10 kHz. For the 1,000 μ F 400 VDC aluminum electrolytic capacitor, there are several packages available. For example, all three styles in Figure 1 are available. Let's choose a snap-in capacitor rated 105 °C such as our Type 381LX. The landing page linked in the previous paragraph leads to our “double” (two side-by-side instances, facilitating what-if scenario exploration) snap-in calculator at <https://www.cde.com/Snapplet/DoubleSnapplet.htm> See the screen capture in Figure 28. We'll be working with the left of the two applets, then later using the arrow between them to automatically transfer a copy of this information over to the right applet so we don't have to type everything twice.

There is a Type drop-down box from which a 381LX is chosen, then the rated voltage, capacitance, and case size are chosen, in that order; left to right, top to bottom is the best workflow. The two ripple currents and frequencies are typed into the appropriate fields. The air temperature near the capacitors we'll assume is 55 °C and type that into the text box. Because there will be two electrolytic capacitors in series, 350 V is entered as the applied voltage, as it is half of the 700 VDC bus voltage in our earlier “rule of thumb” example.

Suppose the air temperature is known to be 55 °C but we wish to explore the effect of no forced convection (i.e. natural convection only) compared to a little bit of airflow from a fan, such as 1 m/s air velocity. We leave the airspeed at 0 in the left applet, click the Calculate button, and obtain an immediate estimate of 6.5 °C core rise and 162,800 hours lifetime. Now we can transfer all that over to the right panel by clicking the “>>” arrow, then edit the airspeed in the right panel, changing it from 0 to 1 m/s. After clicking Calculate in the right applet, we see that the capacitor runs a little cooler and lasts a few years longer. Not only is the lifetime reported, but also the ESR at the two frequencies at the predicted 60 °C core temperature is displayed as 19 m Ω at 300 Hz and 10 m Ω at 10 kHz. This underscores the strong effect that frequency often has on the capacitor ESR.

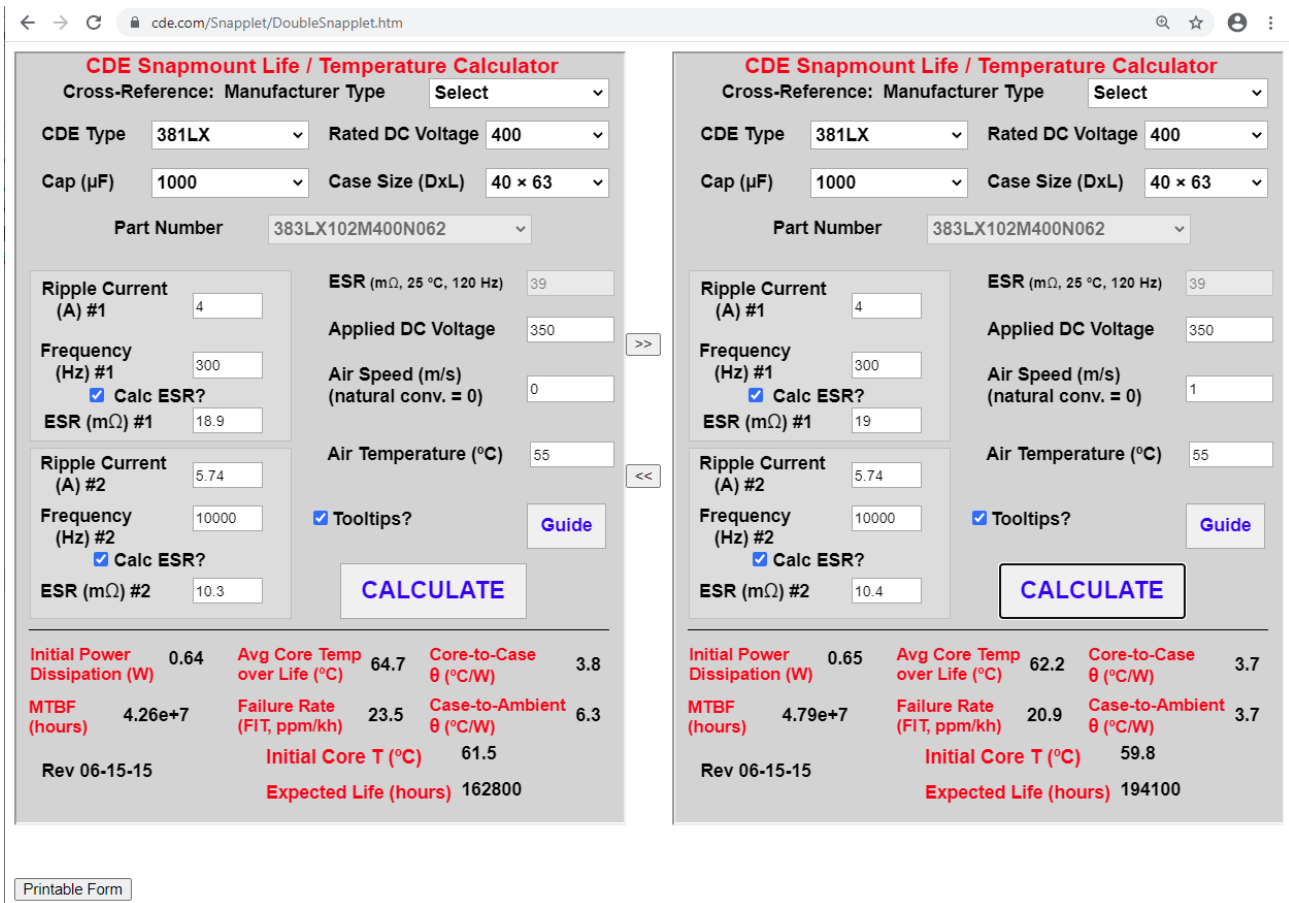

Figure 28: CDE’s Snap-In Life / Temperature Calculator showing inputs and outputs for a 1000 μ F DC link capacitor for use of 2 in series in a 10 horsepower motor drive.

Next, we will use a different online tool to calculate the performance of a single film capacitor. This tool is at <https://www.cde.com/filmcalc> and a screen capture is seen in Figure 29. The two lower charts in the figure are from the “Ambient” and “Airflow” tabs of this applet. We have chosen a single Type UNL 50 μ F 750 VDC rated capacitor with a size of 50 \times 63 mm. This compares to two 40 \times 63 mm electrolytic capacitors. It has an even greater typical lifetime under these operating conditions than the electrolytics.

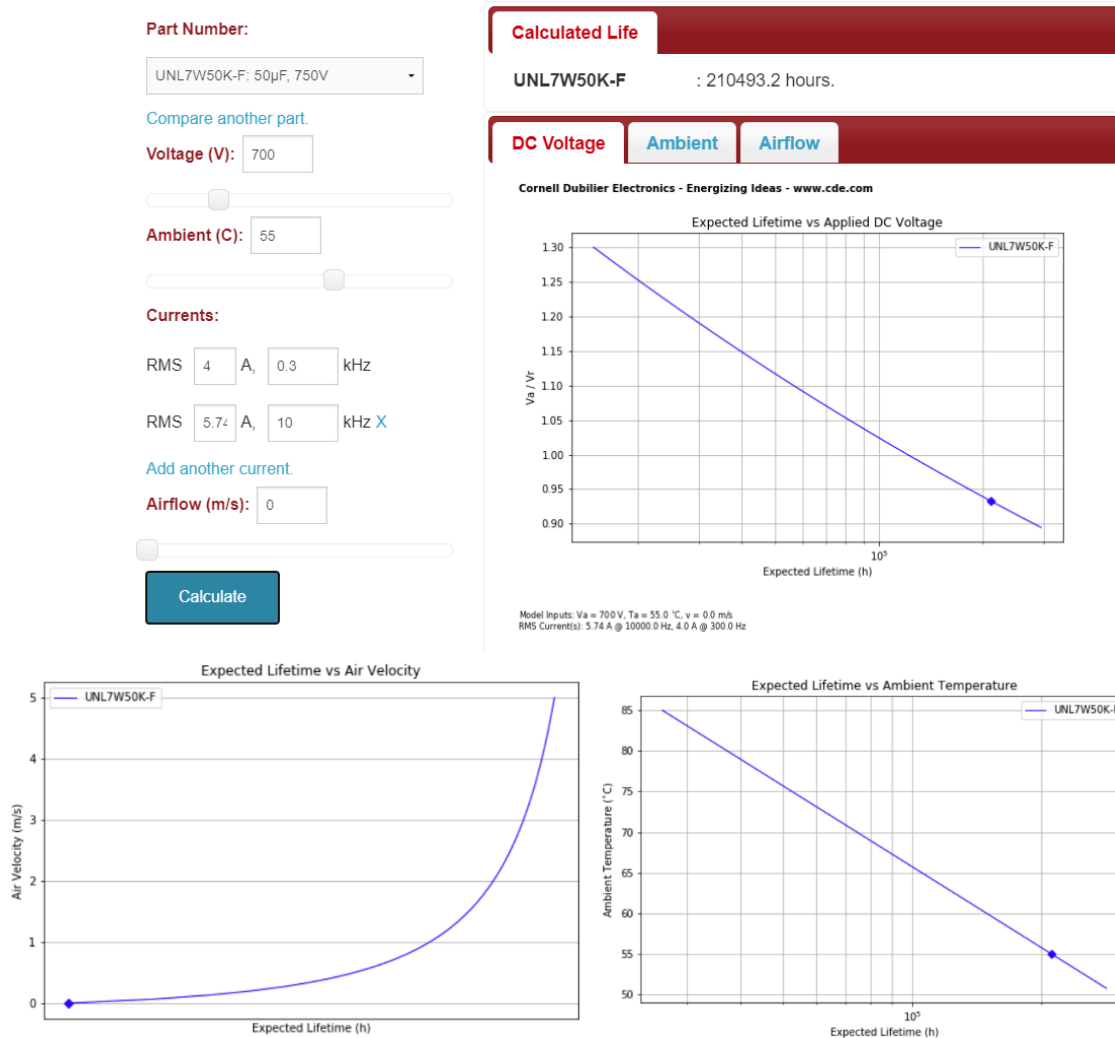

Figure 29: CDE's Film Lifetime Calculator showing inputs and outputs for a 50 μ F 750 VDC rated DC link capacitor for use in a 10-horsepower motor drive.

Conclusions

In this paper we have discussed the considerations involved in selecting the right type of DC link bus capacitors for inverter power systems and have presented generalized, per-unit RMS analysis results for the source input and inverter output stages, and we have discussed how these RMS ripple current components combine. We have also discussed how the ESR varies with frequency and the impact of the harmonic spectra for various aspects of the input and inverter current pulse trains. We have presented some rough guides on how to select a range of candidate capacitors based on power and voltage levels. Two examples of how to use Cornell Dubilier's web-based impedance modeling and lifetime modeling applets, one for an aluminum electrolytic capacitor and one for a film capacitor, were covered for a specific 10 horsepower inverter with known application environmental conditions.

Learn more at: <https://www.tti.com/content/ttiinc/en/manufacturers/cornell-dubilier.html>