

## Why Charging Inlets are Critical to EV Innovation

There are only a few cues on the exterior of an electric vehicle to let an observer know that it is an EV and not gas-powered: the absence of a tailpipe, the lack of a front grille, and the presence of a charging inlet.

The inlet is a component that consumers will interact with frequently — potentially on a daily basis — and as such it will play a major role in shaping consumer preferences, keeping EVs safe, and ensuring that EV use continues to accelerate.

The right inlet can help reduce charging times by providing the power demanded by larger batteries and addressing consumer range anxiety. Its design should also have flexibility, scale and durability in mind, thus enabling OEMs to use the technology in vehicles around the world. And it should be easy to assemble and easy to service or replace if needed.

In short, the charging inlet is a component destined to have an outsized impact both on EVs' acceptance and on OEMs' success with EVs over time.



**A PIVOTAL ROLE**

For EV consumers, most of whom will be first-time buyers in the next several years, the charging inlet will be at the center of a new driving experience. No longer will drivers simply pull into a service station, gas up within minutes, and be on their way. Today, EV drivers have to adjust to longer charging times, which can range from 20 to 60 minutes at fast-charging stations and longer for at-home charging.

Automakers, for their part, face an array of challenges. As OEMs counter consumers' range anxiety by including larger batteries in their vehicles, they will also need inlets that can safely provide a higher level of electric power to keep charging times down and use temperature feedback to optimize charging rates. At the same time, they are looking for inlets that are easy to assemble and install while remaining adaptable to a wide range of requirements — including a variety of regional standards, electrical architectures and vehicle platforms.

In addition, OEMs must consider how the inlets will hold up over time. Technicians will require a service-friendly design that avoids complex and expensive repair procedures, such as replacing an entire wiring harness.

As a defining element of EV technology, inlets require an intelligent design approach that can address all of these challenges.

**FASTER CHARGING**

Most inlets provide two interfaces for charging. The first interface feeds AC power to an onboard charger, which converts the power to DC to charge the battery; this method is typically limited to 11 kW and low amperage, so it takes hours to fully charge. The second interface, in contrast, uses DC power to charge the battery much more quickly, often in less than an hour for today's vehicles.

**Modular Charging Inlet**

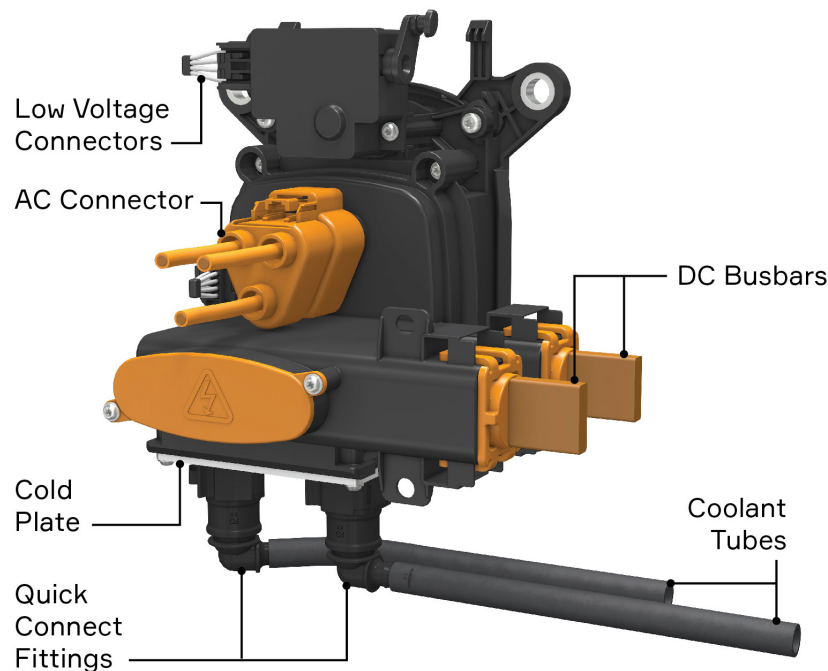

The biggest obstacle to fast charging is heat. The higher the electrical current running through a conductor, the higher the amount of heat generated. Many OEMs are issuing requirements to allow for 500A of sustained DC current today, and up to 800A or more in the future for short durations — current levels that can generate enough heat to damage components unless properly managed. There are two tools that OEMs can use to address this challenge.

### Temperature Sensing

The first tool is accurate and rapid temperature sensing. Regulations commonly stipulate that the terminal must not exceed a total operating temperature of 90° C to protect consumers who might touch the area. Advanced temperature-sensing technology can enable a system to track terminal temperatures precisely, preventing the terminals from soaring above that 90° limit in a thermal runaway.

Providing accurate temperature-sensing feedback to the system is also critical for delivering the maximum charge power to the battery. The challenge is that, although temperature sensors are embedded into the charging inlet, electrical isolation requirements prevent the sensors from being directly attached to the heat source — and that separation results in a time delay, as well as a difference between the temperature at the source and the temperature at the sensor.

Without accurate data, the charging system cannot perform at its limit. The charging system software would have to conservatively rein in the charging rate to account for the time delay and temperature mismatch.

Some designs are able to compensate for these limitations, providing for accuracy as tight as 3° C and causing a negligible time delay. These designs allow the system software to achieve real-time adaptable charging, maximizing the power at all times.

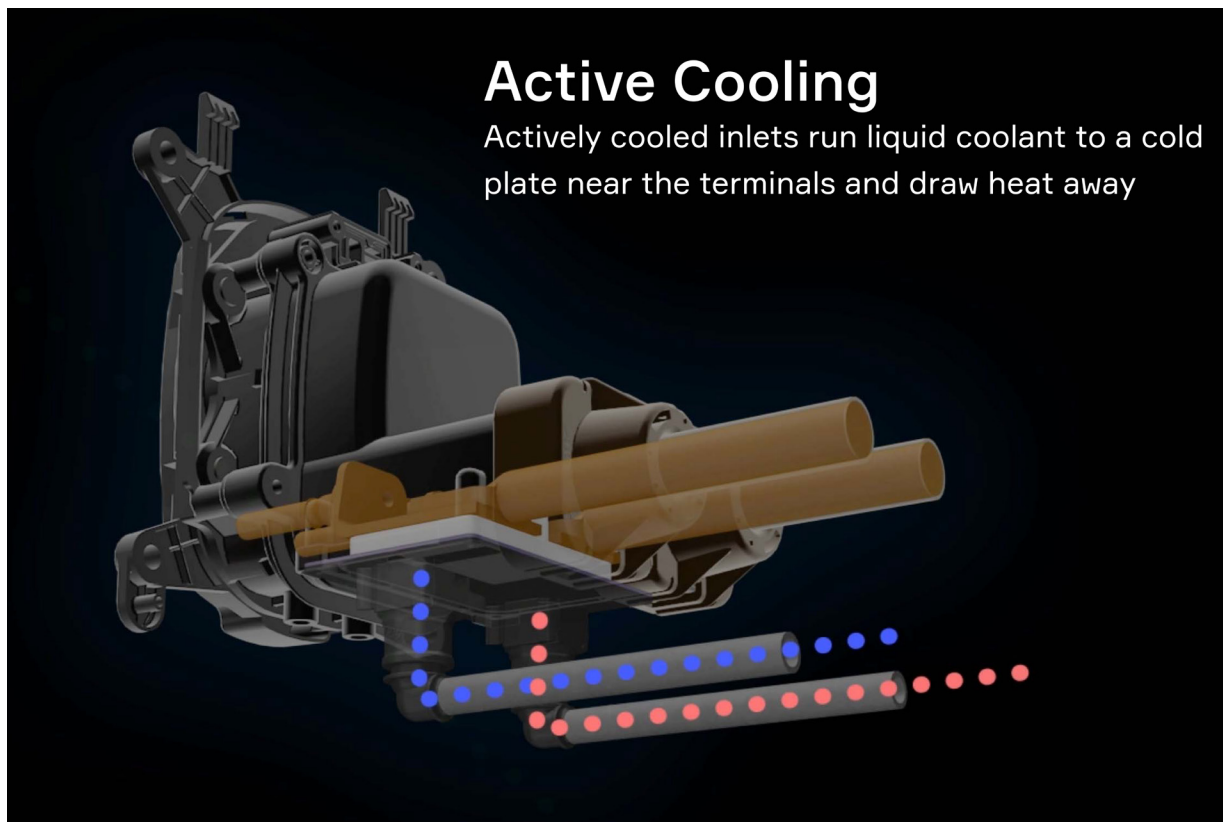

**Cooling**

The second tool OEMs can use to address the heat generated through fast charging is employing cooling techniques. While many infrastructure charging stations are implementing cooling in their equipment, those measures actually have little effect on the vehicle side of the inlet, due to the location of the DC terminals and busbars. Another challenge is that the industry-standard DC pin size was not designed to charge at the levels that OEMs are seeking in the future. Adding larger cables alone can pull heat from the pin, but that works only to a certain point, due to the mismatch between the terminal size and the cable size.

Cooling of the power terminals is necessary to allow for the power levels needed in the future. Cooling can be either passive or active.

Passive cooling consists of “potting” material around the power terminals to draw away heat. However, adding the potting material or additional heat sinks can make it more difficult to build the wiring harness or to service the inlet. And while the potted material or heat sink will pull heat away from the terminal, this passive cooling approach offers no way to remove heat further except through the ambient air. As a result, much of the heat stays in the block of material, particularly if the ambient temperature is high.

Active cooling, on the other hand, enables the system to receive much higher current for much longer. Designers can keep the temperature of the charging pin down by actively running liquid coolant close to the pin. A cold plate is attached to the terminals or to the busbars adjacent to the pin, and the coolant pulls heat away from the plate. With active cooling, the ambient air around the inlet becomes less of a factor; that is, any rise in terminal temperature will be tied to the temperature of the coolant and largely unaffected by the ambient temperature.

Aptiv’s tests have shown that this technique can limit the pin’s temperature rise to an acceptable increase over the coolant temperature at 500A — indefinitely. Without active cooling, running 500A of current would be limited to 10 to 15 minutes.

Coupled with real-time temperature sensing, active cooling lets the OEM control the maximum power that can be delivered to the battery, though it adds a level of complexity and cost. Still, there are multiple systems in a vehicle that require coolant — such as inverters, batteries, converters and other power electronic devices — so there is often a source of coolant in the vehicle to draw from.

Extending the higher rate of current for longer periods is key to reducing charge times. In a simplified example that ignores battery de-rating

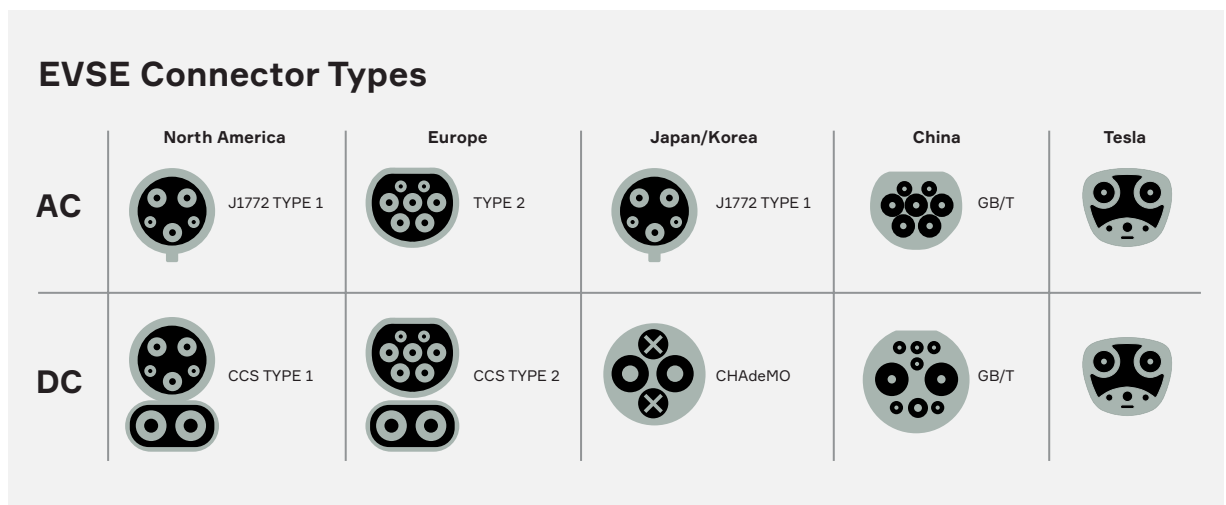

effects, with a current of 500A at the 400V that is on the horizon for EVs, a 100 kWh battery could fully charge in 30 minutes. With some architectures moving to 800V, that time could go down to about 10 minutes, similar to a typical stop at the gas station today.

**FLEXIBILITY**

At the same time, global OEMs are looking at electrifying their vehicles in regions around the world. To do that efficiently and economically, they will need charging inlet technology that is adaptable for every region and for every vehicle configuration.

One aspect of this flexibility involves adapting to regional standards. North America, Europe, Asia — each region has its own standard configuration for both the AC and DC vehicle inlets. With a consistent design philosophy, an OEM can use inlets that share multiple components while conforming to different interface standards. They should also accommodate the various regional inlets in the same vehicle packaging and mounting hardware, a key concern for global platforms.

A second aspect of flexibility is using the same inlet technology for different vehicle models, each with its own electrical architecture and physical structure. For example, depending on the physical configuration in a particular vehicle, the packaging may require high-voltage cables

or busbars to route to the left or to the right. Perhaps they should be routed straight down instead, or even straight back into the vehicle. An inlet that easily allows various wire dress directions on different platforms gives OEMs the means to achieve economies of scale as they reuse the core inlet across multiple platforms.

Likewise, the faceplate of the inlet may need to be a different shape on different vehicles, or there may need to be different mounting points. The OEM may want to put different logos on them or add LED lights to some. A modular design can accommodate each of these variations while retaining common components.

OEMs also may require the option to use busbars instead of cables to connect an inlet’s DC plugs to the battery. Busbars are increasingly becoming an attractive option, because they can carry higher currents than cables with the same cross-sectional area. They may also address routing concerns by bending through parts of a vehicle that cables cannot, and they help to enable automated assembly.

Another feature that OEMs should consider — one that significantly affects production costs — is ease of manufacture for the tier-one supplier performing the final assembly wiring. The charging inlet is a complex apparatus with multiple parts and connectors that must manage both low and high voltage. Some suppliers deliver inlets to the wiring-tier production plant as a package of loose components and unassembled

**Inlet Routing Options**

Aptiv inlets have different configurations for any needed HV cable or busbar direction.

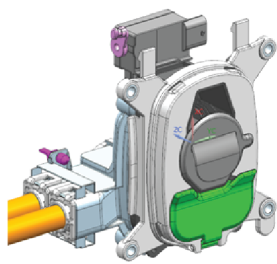

Routing left

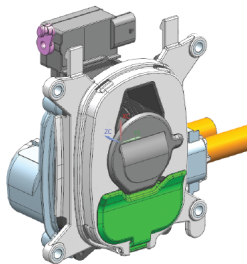

Routing right

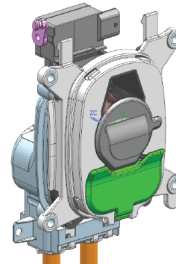

Routing down

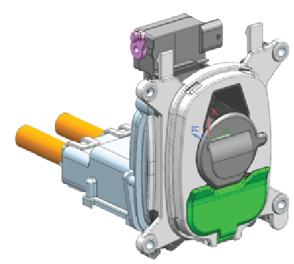

Routing out

pieces. Although the upfront price for these inlets tends to be lower, the overall costs are simply pushed downstream and show up in greater labor hours, in a more complex build at the wiring tier, and in potential quality problems. In contrast, charging inlets of modular design that require minimal assembly not only reduce total costs but also ensure quality.

### SERVICEABILITY

EVs are here to stay, and the market is mushrooming. According to Boston Consulting Group, EVs will make up 45 percent of all new cars sold in just 14 years. But with this growth surge comes a service gap. According to one recent study, only 3 percent of automotive technicians know how to work on EVs. Many repair shops do not have the equipment to do so, or they see little need to train their staffs, given that EVs require much less maintenance than gasoline- or diesel-driven vehicles. Moreover, technicians can be as daunted as laymen by the numerous “high voltage” warning labels in EVs.

Despite the low-maintenance advantage of EVs, these vehicles will need service simply due to constant use — and misuse. One of the most-used parts will be the charging inlet, leading to normal wear and tear. But while today’s inlets are durable, they could also be the target of cleaning solvents, power washers, angry kicks and other forms of abuse. As nearly every manufacturer can attest, the wondrous ability of humans to invent life-enhancing products is nearly equaled, if not surpassed, by our ability to damage them.

With this in mind, OEMs should include inlets in their portfolios that are designed so that service technicians can potentially replace them without having to remove an entire wiring harness.

This is possible with the right connectors at the inlet, allowing technicians to remove a unit via a straightforward series of steps that involve unplugging wires and unbolting busbars. Using an in-line connector for the AC wires can allow the terminals to be replaced easily as well. This approach leaves intact the rest of the wiring harness, avoiding a time-consuming and expensive repair procedure.

### COMPETITIVE ADVANTAGE

With our deep expertise in high-voltage electrification, Aptiv understands the unique requirements of next-generation electrical architectures. We know what it takes to build electrical components efficiently, to leverage the latest technologies for maximum benefit, and to build innovative solutions that are flexible and durable. Today we are applying that expertise to charging inlets.

For decades, consumers have evaluated a vehicle’s performance by its ability to quickly reach 60 mph from a dead start. In the EV era, which we are now entering, the marquee advantage might very well be a short charging time. A driver with a sporty model that takes 30 minutes to charge might look on with envy at another sporty model that can charge up and be back on the road in 10 or 15 minutes. Speed is still of the essence, but it will now be off-road speed as well as on-road acceleration that makes a lasting impression.

The charging inlet will play a central role in these comparisons. Inlets that can help charge up powerful batteries safely and quickly will be part and parcel of what it is to be a quality vehicle in the future.

## ABOUT THE AUTHORS



**Don Bizon**  
Global Product Manager

Don Bizon leads the high-voltage EV charger product portfolio at Aptiv, as well as business development for charging inlets and high voltage interconnects in the Americas region. Don started his career at Aptiv in 1990, holding various positions in engineering and product line management.



**Dominik Hermes**  
Global Product Line & Advanced Engineering Manager, Inlets

Dominik Hermes leads the inlet product portfolio at Aptiv and manages the global advanced engineering organization for inlets. Dominik joined Aptiv more than 10 years ago, assuming multiple roles within the groups focused on high voltage and consumer connectivity components.

---

LEARN MORE AT [APTIV.COM/EMOBILITY](https://www.aptiv.com/emobility) →