

Performance Under Pressure

Pressure Sensors Databook

www.allsensors.com

P 408.225.4314 F 408.225.2079



MEMS Pressure Sensors

PDF Catalog

Table of Contents

[Help me Choose](#)

Product Matrix	Section	0-1
Evaluation Kit	Section	0-2

[Millivolt Output \(compensated\)](#)

ADCX Series Pressure Sensors (DS-0091)	Section	1-1
MLV Series Pressure Sensors (DS-0274)	Section	1-2
AXCX Series Low Pressure Sensors		
- C-Grade Pressure Sensors (DS-0094)	Section	1-3
- H-Grade Pressure Sensors (DS-0095)	Section	1-4
- Prime Grade Pressure Sensors (DS-0096)	Section	1-5
MDCX Series Miniature Low Pressure Sensors (DS-0108)	Section	1-6
Special Series Blood Pressure Millivolt Output Pressure Sensors (DS-0048)	Section	1-7
ACPC Series		
- C-Grade Pressure Sensors (DS-0106)	Section	1-8
- H-Grade Pressure Sensors (DS-0107)	Section	1-9
- Prime Grade Pressure Sensors (DS-0110)	Section	1-10
- Barometric Pressure Sensors (DS-0039)	Section	1-11

Table of Contents

Digital Output

DLH Series Pressure Sensors (DS-0355)	Section	2-1
DLHR Series Pressure Sensors (DS-0350)	Section	2-2
DLV Series Pressure Sensors (DS-0336)	Section	2-3
DLVR Series Pressure Sensors (DS-0300)	Section	2-4
DLC Compact Series Pressure Sensors (Coming Soon)	Section	2-5
ADO Series Digital Output Pressure Sensors		
- Standard (DS-0012)	Section	2-6
- Mil Spec Digital Pressure Sensors (DS-0009)	Section	2-7
- Barometric Digital Pressure Sensors (DS-0010)	Section	2-8
- Mil Spec Barometric Digital Pressure Sensors (DS-0011)	Section	2-9

Amplified Output

ADCA Series Sensors (DS-0368)	Section	3-1
AXCA Series Amplified Middle Pressure Sensors		
- Standard (DS-0028)	Section	3-2
- Prime Grade Amplified Middle Pressure Sensors (DS-0029)	Section	3-3
- Mil Spec Amplified Middle Pressure Sensors (DS-0031)	Section	3-4
- Barometric Pressure Sensors (DS-0041)	Section	3-5
- ASCX Series Compatible Amplified Pressure Sensors (DS-0023)	Section	3-6
MAMP Series Pressure Sensors		
- Standard (DS-0101)	Section	3-7
- Prime Grade Pressure Sensors (DS-0102)	Section	3-8
- Medical Breathing Pressure Sensors (DS-0097)	Section	3-9
SAMP Series Pressure Sensors		
- Standard (DS-0103)	Section	3-10
- Barometric Pressure Sensors (DS-0040)	Section	3-11
Special Series Respiratory Amplified Pressure Sensors (DS-0027)	Section	3-12

Table of Contents

Basic Output (uncompensated)

BLC Series Pressure Sensors (DS-0353)	Section	4-1
BLCR Series Pressure Sensors (DS-0354)	Section	4-2
BLV Series Pressure Sensors (DS-0275)	Section	4-3
BLVR Series Pressure Sensors (DS-0280)	Section	4-4
BDS Series Pressure Sensors (DS-0266)	Section	4-5

Media Isolated Sensors (Millivolt)

CPM 502 Series (DS-0347)	Section	5-1
CPM 602 Series (DS-0348)	Section	5-2
SPM 401 Series (DS-0343)	Section	5-3
SPM 402 Series (DS-0344)	Section	5-4

Media Isolated Sensors (Amplified)

CPA 502 Series (DS-0339)	Section	6-1
CPA 602 Series (DS-0340)	Section	6-2
SPA 401 Series (DS-0341)	Section	6-3
SPA 402 Series (DS-0342)	Section	6-4

Appendix A: Packaging

A-Package	Section	7-1
E-Package, P-Package	Section	7-2
M-Package	Section	7-3
C-Package	Section	7-4
B-Package	Section	7-5
N-Package	Section	7-6
D-Package, U-Package	Section	7-7
IS Package, IC-Package	Section	7-8

Table of Contents

Appendix B: White Papers

Pressure Point #1: Pressure Measurement Types	Section	8-1
Pressure Point #2: Understanding Accuracy and Precision for MEMS Pressure Sensors	Section	8-2
Pressure Point #3: Linearity Measurements for MEMS Pressure Sensors	Section	8-3
Pressure Point #4: Dual Die Compensation for MEMS Pressure Sensors	Section	8-4
Pressure Point #5: Special Considerations for Mounting and Handling Pressure Sensors	Section	8-5
Pressure Point #6: Position Sensitivity in Pressure Sensors	Section	8-6
Pressure Point #7: Understanding Common-Mode Differential Pressure	Section	8-7
Pressure Point #8: Bandwidth vs. Signal to Noise Tradeoff	Section	8-8
Pressure Point #9: Pressure Sensor Technologies	Section	8-9
Pressure Point #10: Media Capability	Section	8-10
Pressure Point #11: Calculating Flow Rate from Pressure Measurements	Section	8-11
Pressure Point #12: Making MEMS Pressure Sensors Easier to Use (Part I)	Section	8-12
Pressure Point #12: Making MEMS Pressure Sensors Easier to Use (Part II)	Section	8-13
White Paper: How to Minimize Warm-Up Drift in Pressure Sensors	Section	8-14
White Paper: Design Considerations for Pressure Sensing Integration	Section	8-15

Appendix C: Additional Resources

Definition of Terms	Section	9-1
Pressure Unit Conversion Constants Chart	Section	9-2

Product Matrix

Device Family	Datasheet	Pressure Range		Grade	Compensated Temperature Range C°	Output	Measurement Type	Package	Housing Material	Media Compatibility
		US Customary	Metric							
ADCX	DS-0091	0.5 to 30 inH2O	0.1 to 7.5 kPa	S	0 to 50 (70)	mV	D	A	P	1
MLV	DS-0274	1 inH2O to 150 PSI	0.25 to 1035 kPa	S	0 to 50	mV	D, A	A, E	P	1
AXCX	DS-0094, 0095, 0096	4 inH2O to 150 PSI	1 to 1035 kPa	C / H / P	0 to 70	mV	D, A	A	P	1
MDCX	DS-0108	2 to 30 inH2O	0.5 to 7.5 kPa	S	0 to 50 (70)	mV	D, G	M	P	1
Blood Pressure	DS-0048	160.5 inH2O	300 mmHg	S	10 to 50	mV, 4V	D, G	A, M	P	1
ACPC	DS-0106, 0107, 0110, 0039	4 inH2O to 100 PSI	1 to 690 kPa	C / H / P	0 to 50 (70)	mV	D, A, G	C	P	1
DLH	DS-0355	5 to 60 inH2O	1.25 to 15 kPa	S / P	0 (-20) to 70 (85)	Digital	D, G	E	P	1
DLHR	DS-0350	0.5 to 60 inH2O	0.1 to 15 kPa	S / P	0 (-20) to 70 (85)	Digital	D, G	E	P	1
DLV	DS-0336	5 to 60 PSI	1.25 to 15 kPa	S / P	0 (-20) to 70 (85)	Digital	D, G	E	P	1
DLVR	DS-0300	0.5 to 60 inH2O	0.1 to 15 kPa	S / P	0 (-20) to 70 (85)	Digital	D, G	E	P	1
ADO	DS-0012, 009, 0010, 0011	5 inH2O to 100 PSI	1.25 to 690 kPa	S / M	-40 to 125	Digital	D, A	A	P	1
ADCA	DS-0368	0.25 to 60 inH2O	0.06 to 15 kPa	S / P / M	-40 to 125	4V	D, G	A	P	1
AXCA	DS-0028, 0029, 0031, 0041, 0023	0.3 to 150 PSI	2.1 to 1035 kPa	S / P / M	-40 to 125	4V	D, A, G	A	P	1
MAMP	DS-0101, 0102, 0097	0.5 to 60 inH2O	0.1 to 15 kPa	S / P	-25 to 85	4V	D, G	P	P	1
SAMP	DS-0103, 0040	0.3 to 30 PSI	2.1 to 1035 kPa	S	5 to 50	4V	D, A, G	P	P	1
Medical Breath	DS-0027	47 inH2O	120 cmH2O	P	-25 to 85	4V	D	A	P	1
BLC	DS-0353	1 to 30 inH2O	0.25 to 7.5 kPa	S	Uncompensated	mV	D, A	D, U	P	1
BLCR	DS-0354	1 to 30 inH2O	0.25 to 7.5 kPa	S	Uncompensated	mV	D	D, U	P	1
BLV	DS-0275	1 to 30 inH2O	0.25 to 7.5 kPa	S	Uncompensated	mV	D, G	B	P	1
BLVR	DS-0280	1 to 30 inH2O	0.25 to 7.5 kPa	S	Uncompensated	mV	D, G	B	P	1
Baro-Specials	DS-0010, 0011, 0039, 0040, 0041	8.5 to 16 PSI	60 to 110 kPa	S / P / M	-40 to 125	mV, 4V, Digital	A	A, C, P	P	1
CPM 502	DS-0347	7.5 to 9000 PSI	50 to 60000 kPa	S	0 to 85	mV	G, A	IC	C	2
CPM 602	DS-0348	30 to 6000 PSI	200 to 40000 kPa	S	0 to 85	mV	G	IC	C	2
SPM 401	DS-0343	1.5 to 100 PSI	10 to 700 kPa	S	-40 to 125	mV	G	IS	S	2
SPM 402	DS-0344	5 to 500 PSI	35 to 3500 kPa	S	-40 to 125	mV	G, A	IS	S	2
CPA 502	DS-0339	7.5 to 9000 PSI	50 to 60000 kPa	S	0 to 85	4V	G, A	IC	C	2
CPA 602	DS-0340	30 to 6000 PSI	200 to 40000 kPa	S	0 to 85	4V	G	IC	C	2
SPA 401	DS-0341	1.5 to 100 PSI	10 to 700 kPa	S	-40 to 125	4V	G	IS	S	2
SPA 402	DS-0342	5 to 500 PSI	35 to 3500 kPa	S	-40 to 125	4V	G, A	IS	S	2

Identification Key: Output mV Millivolt Digital Digital 4V Amplified	Units ■ Red Specified Pressure Range ■ Black Converted Pressure Range	Measurement Type D Differential A Absolute G Gage	Media Compatibility 1 Non-Corrosive, Non-Condensing Dry Air and Gas 2 Harsh Media	Housing P Plastic C Ceramic S Stainless Steel	Grade S Standard C C Grade (Good) H H Grade (Better) P Prime Grade (Best) M Military
---	--	--	---	--	---

Package Series

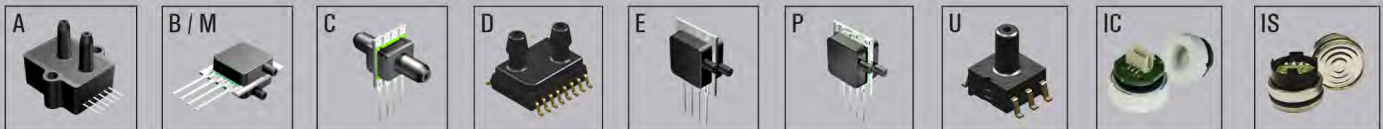

Summary: Sensor Evaluation Kit EK-01

General description	Easily evaluate Analog and Digital Sensors ZF socket allows instant electrical connection
Sensor Type	Analog, Digital
Measurement	Display data from Digital parts in convenient units Choice of 12 units of measurement
Data Display	Capture data from Digital parts to CSV text file Includes sample index and timestamp
Driver	Uses standard Windows in-box USB drivers No separate download or CD needed
Lab test equipment	Standard terminals for Lab test equipment Dual 4mm "banana" binding posts
Price	\$150 (globally) Includes: evaluation board, software, 1 adapter of choice, USB

List of supported ASC product series and required adapters.

EK-01 Product Series Adapter Cross Reference

Series	Adapter
ACPC	ANA-02
ADCA	ANA-04
ADCX	ANA-01
ADUX	ANA-03
ASCX	ANA-05
AXCA	ANA-04
AXCX	ANA-01
BLV	ANA-03
BLVR	ANA-03
DLV	DIG-01
DLVR	DIG-01
FPS	DIG-02
MAMP	ANA-06
MCI (DIP)	DIG-06
MCI (SIP)	DIG-04
MCS	DIG-05
MDCX	ANA-02
MLV (A Pkg)	ANA-01
MLV (E Pkg)	ANA-02
SAMP	ANA-06
XHI	DIG-03

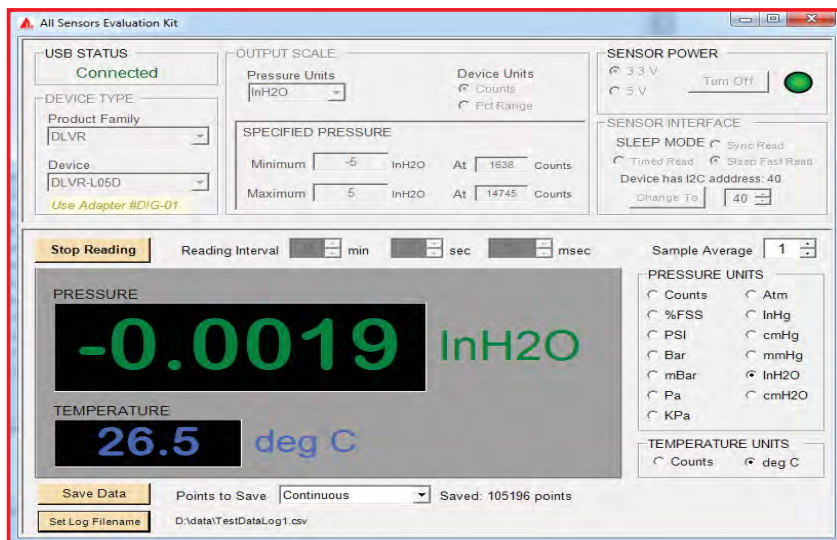
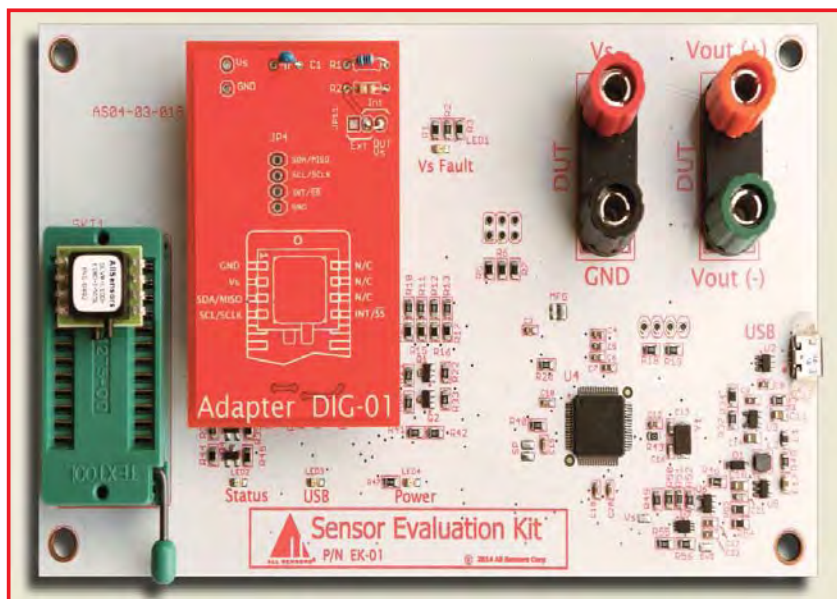

Millivolt Output

MILLIVOLT OUTPUT PRESSURE SENSORS

Low Pressure (0.5" H₂O to 30" H₂O) Sensors

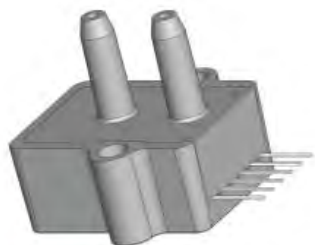

Features

- 0 to 0.5" H₂O to 0 to 30" H₂O Pressure Ranges
- Temperature Compensated
- Calibrated Zero and Span

Applications

- Medical Instrumentation
- Environmental Controls
- HVAC

General Description

The Millivolt Output pressure sensor is based upon a proprietary technology to reduce all output offset or common mode errors. This model provides a calibrated millivolt output with superior output offset characteristics. Output offset errors due to change in temperature, stability to warm-up, stability to long time period, and position sensitivity are all significantly reduced when compared to conventional compensation methods. In addition the sensor utilizes a silicon, micromachined, stress concentration enhanced structure to provide a very linear output to measured pressure.

These calibrated and temperature compensated sensors give an accurate and stable output over a wide temperature range. This series is intended for use with non-corrosive, non-ionic working fluids such as air, dry gases and the like.

The output of the device is ratiometric to the supply voltage and operation from any D.C. supply voltage up to +16 V is acceptable.

Physical Dimensions

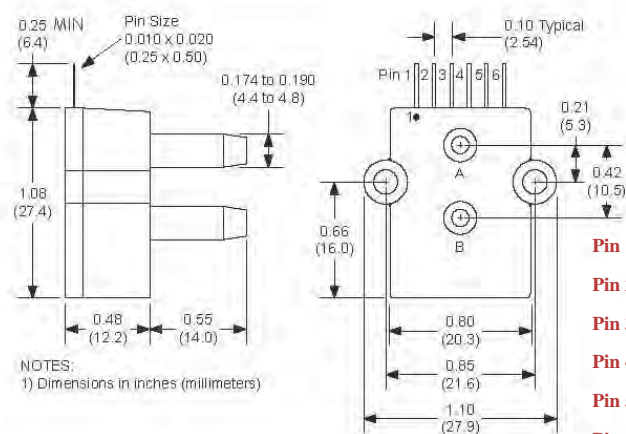

Equivalent Circuit

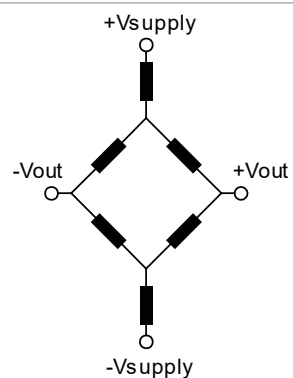

Input Resistance 4.5 k ohm
Output Resistance 1.5 k ohm

Approvals

MKT	DATE	MFG	DATE	ENG	DATE	QA	DATE
<input type="checkbox"/> As Is <input type="checkbox"/> With Change		<input type="checkbox"/> As Is <input type="checkbox"/> With Change		<input type="checkbox"/> As Is <input type="checkbox"/> With Change		<input type="checkbox"/> As Is <input type="checkbox"/> With Change	

ALL SENSORS

DS-0091 REV C

Pressure Sensor Ratings

Supply Voltage Vs, max	16 Vdc
Common-mode pressure	-10 to +10 psig
Lead Temperature, max (soldering 2-4 sec.)	270°C

Environmental Specifications

Temperature Ranges	
Compensated	0 to 50(70)° C
Operating	-25 to 85° C
Storage	-40 to 125° C
Humidity Limits	0 to 95% RH (non condensing)

Standard Pressure Ranges

Part Number	Operating Pressure	Nominal Span	Proof Pressure	Burst Pressure
0.5 INCH-D-MV	0 - 0.5" H2O	10mV	100 "H2O	200 "H2O
1 INCH-D-MV	0 - 1" H2O	10 mV	100 "H2O	200 "H2O
2 INCH-D-MV	0 - 2" H2O	10mv	100 "H2O	200 "H2O
5 INCH-D-MV	0 - 5" H2O	20 mV	200 "H2O	300 "H2O
10 INCH-D-MV	0 - 10" H2O	20 mV	200 "H2O	300 "H2O
20 INCH-D-MV	0 - 20" H2O	20 mV	200 "H2O	500 "H2O
30 INCH-D-MV	0 - 30" H2O	20 mV	200 "H2O	800 "H2O

Performance Characteristics for 0.5 INCH-D-MV

Parameter, note 1	Minimum	Nominal	Maximum	Units
Operating Range, differential pressure	--	0.5	--	"H2O
Output Span, @ 0.5"H2O, note 5	9.0	10.0	11.0	mV
Offset Voltage @ zero differential pressure	--	--	±500	uV
Offset Temperature Shift (0°C-50°C), note 2	--	--	±250	uV
Offset Warm-up Shift, note 3	--	--	±100	uV
Offset Position Sensitivity (1g)	--	--	±5.0	uV
Offset Long Term Drift (one year)	--	--	±200	uV
Linearity, hysteresis error, note 4	--	0.05	0.25	%fs
Full Scale Shift (0°C-50°C), note 2	--	--	±200	uV

Performance Characteristics for 1 INCH-D-MV

Parameter, note 1	Minimum	Nominal	Maximum	Units
Operating Range, differential pressure	--	1.0	--	"H2O
Output Span, @ 1"H2O, note 5	9.0	10.0	11.0	mV
Offset Voltage @ zero differential pressure	--	--	±500	uV
Offset Temperature Shift (0°C-50°C), note 2	--	--	±250	uV
Offset Warm-up Shift, note 3	--	--	±100	uV
Offset Position Sensitivity (1g)	--	--	±50	uV
Offset Long Term Drift (one year)	--	--	±200	uV
Linearity, hysteresis error, note 4	--	0.05	0.25	%fs
Full Scale Shift (0°C-50°C), note 2	--	--	±200	uV

MILLIVOLT LOW PRESSURE SENSORS

Performance Characteristics for 2 INCH-D-MV

Parameter, note 1	Minimum	Nominal	Maximum	Units
Operating Range, differential pressure	--	2.0	--	"H2O
Output Span, note 5	9.0	10.0	11.0	mV
Offset Voltage @ zero differential pressure	--	--	±500	uV
Offset Temperature Shift (0°C-50°C), note 2	--	--	±250	uV
Offset Warm-up Shift, note 3	--	--	±100	uV
Offset Position Sensitivity (1g)	--	--	±50	uV
Offset Long Term Drift (one year)	--	--	±200	uV
Linearity, hysteresis error, note 4	--	0.05	0.25	%fs
Full Scale Shift (0°C-50°C), note 2	--	--	±200	uV

Performance Characteristics for 5 INCH-D-MV

Parameter, note 1	Minimum	Nominal	Maximum	Units
Operating Range, differential pressure	--	5.0	--	"H2O
Output Span, note 5	19.0	20.0	21.0	mV
Offset Voltage @ zero differential pressure	--	--	±500	uV
Offset Temperature Shift (0°C-50°C), note 2	--	--	±150	uV
Offset Warm-up Shift, note 3	--	--	±50	uV
Offset Position Sensitivity (1g)	--	--	±10	uV
Offset Long Term Drift (one year)	--	--	±100	uV
Linearity, hysteresis error, note 4	--	0.05	0.25	%fs
Full Scale Shift (0°C-50°C), note 2	--	--	±200	uV

Performance Characteristics for 10 INCH-D-MV

Parameter, note 1	Minimum	Nominal	Maximum	Units
Operating Range, differential pressure	--	10.0	--	"H2O
Output Span, note 5	19.0	20.0	21.0	mV
Offset Voltage @ zero differential pressure	--	--	±500	uV
Offset Temperature Shift (0°C-70°C), note 2	--	--	±150	uV
Offset Warm-up Shift, note 3	--	--	±50	uV
Offset Position Sensitivity (1g)	--	--	±5	uV
Offset Long Term Drift (one year)	--	--	±100	uV
Linearity, hysteresis error, note 4	--	0.05	0.25	%fs
Full Scale Shift (0°C-70°C), note 2	--	--	±200	uV

Performance Characteristics for 20 INCH-D-MV

Parameter, note 1	Minimum	Nominal	Maximum	Units
Operating Range, differential pressure	--	20.0	--	"H2O
Output Span, note 5	19.0	20.0	21.0	mV
Offset Voltage @ zero differential pressure	--	--	±500	uV
Offset Temperature Shift (0°C-70°C), note 2	--	--	±150	uV
Offset Warm-up Shift, note 3	--	--	±50	uV
Offset Position Sensitivity (1g)	--	--	±5	uV
Offset Long Term Drift (one year)	--	--	±100	uV
Linearity, hysteresis error, note 4	--	0.05	0.25	%fs
Full Scale Shift (0°C-70°C), note 2	--	--	±200	uV

Performance Characteristics for 30 INCH-D-MV

Parameter, note 1	Minimum	Nominal	Maximum	Units
Operating Range, differential pressure	--	30.0	--	"H2O
Output Span, note 5	19.0	20.0	21.0	mV
Offset Voltage @ zero differential pressure	--	--	±500	uV
Offset Temperature Shift (0°C-70°C), note 2	--	--	±150	uV
Offset Warm-up Shift, note 3	--	--	±50	uV
Offset Position Sensitivity (1g)	--	--	±5	uV
Offset Long Term Drift (one year)	--	--	±100	uV
Linearity, hysteresis error, note 4	--	0.05	0.25	%fs
Full Scale Shift (0°C-70°C), note 2	--	--	±200	uV

Specification Notes

- NOTE 1: ALL PARAMETERS ARE MEASURED AT 12.0 VOLT EXCITATION, FOR THE NOMINAL FULL SCALE PRESSURE AND ROOM TEMPERATURE UNLESS OTHERWISE SPECIFIED. PRESSURE MEASUREMENTS ARE WITH POSITIVE PRESSURE APPLIED TO PORT B.
- NOTE 2: SHIFT IS RELATIVE TO 25°C.
- NOTE 3: SHIFT IS WITHIN THE FIRST HOUR OF EXCITATION APPLIED TO THE DEVICE.
- NOTE 4: MEASURED AT ONE-HALF FULL SCALE RATED PRESSURE USING BEST STRAIGHT LINE CURVE FIT.
- NOTE 5: THE VOLTAGE ADDED TO THE OFFSET VOLTAGE AT FULL SCALE PRESSURE.

Pressure Response: for any pressure applied the response time to get to 90% of pressure applied is typically less than 100 useconds.

All Sensors reserves the right to make changes to any products herein. All Sensors does not assume any liability arising out of the application or use of any product or circuit described herein, neither does it convey any license under its patent rights nor the rights of others.

MLV Series Low Voltage Pressure Sensors

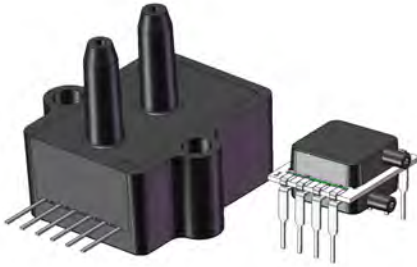

Features

- 1 to 30 inH2O & 5 to 150 PSI Pressure Ranges
- 5V Operation
- High Output
- Low Power Consumption
- Excellent Position Sensitivity
- Low Warm-Up Shift
- Enhanced Front to Back Linearity
- Protective Parylene Coating Option

Applications

- Medical Breathing
- Environmental Controls
- HVAC
- Industrial Controls
- Portable/Hand-Held Equipment

General Description

The MLV Series Compensated Sensor is based on All Sensors' CoBeam²™ Technology. The device provides a high output signal at a low operating voltage while maintaining comparable output levels to traditional equivalent compensated millivolt sensors operating at higher voltages. This lower supply voltage gives rise to improved warm-up shift while the CoBeam² Technology itself reduces package stress susceptibility resulting in improved overall long term stability. The technology also vastly improves position sensitivity compared to conventional single die devices.

These calibrated and compensated sensors give an accurate and stable output over a wide temperature range. This series is intended for use with non-corrosive, non-ionic working fluids such as air, dry gases and the like. A protective parylene coating is optionally available for moisture/harsh media protection. The output is also ratiometric to the supply voltage and designed to operate at 5.0 volts DC.

Standard Pressure Ranges					Equivalent Circuit
Device	Operating Range	Proof Pressure	Burst Pressure	Nominal Span	
MLV-L01D	±1 inH2O	100 inH2O	300 inH2O	7 mV	
MLV-L02D	±2 inH2O	100 inH2O	300 inH2O	10 mV	
MLV-L05D	±5 inH2O	200 inH2O	300 inH2O	15 mV	
MLV-L10D	±10 inH2O	200 inH2O	300 inH2O	20 mV	
MLV-L20D	±20 inH2O	200 inH2O	500 inH2O	20 mV	
MLV-L30D	±30 inH2O	200 inH2O	800 inH2O	20 mV	
MLV-005D	±5 PSI	10 PSI	30PSI	25 mV	
MLV-015D	±15 PSI	60 PSI	120 PSI	37.5 mV	
MLV-015A	0 - 15 PSIA	60 PSI	120 PSI	37.5 mV	
MLV-030D	±30 PSI	90 PSI	150 PSI	37.5 mV	
MLV-100D	±100 PSI	200 PSI	250 PSI	41.67 mV	
MLV-150D	±150 PSI	200 PSI	250 PSI	37.5 mV	

Pressure Sensor Maximum Ratings		Environmental Specifications	
Supply Voltage (Vs)	12 Vdc	Temperature Ranges	
Common Mode Pressure		Compensated	0°C to 50°C
InH2O Devices (L01, L02, L05, L10, L20, L30)	10 psig	Operating	-25°C to 85 °C
PSI Devices (005, 015, 030, 100, 150)	50 psig	Storage	-40°C to 125 °C
Lead Temperature (soldering 2-4 sec.)	270 °C	Humidity Limits	0 to 95% RH (non condensing)

Performance Characteristics for MLV Series (InH2O)

ALL PARAMETERS ARE MEASURED AT 5.0 VOLT EXCITATION AND ROOM TEMPERATURE UNLESS OTHERWISE SPECIFIED. PRESSURE MEASUREMENTS ARE WITH POSITIVE PRESSURE APPLIED TO PORT B (THE ONLY PORT FOR THE SINGLE PORT CONFIGURATION PACKAGES).

Parameter	Min	Typ	Max	Units	Notes
Output Span					
L01D @ 1 inH2O	6.0	7.0	8.0	mV	4
L02D @ 2 inH2O	9.0	10.0	11.0	mV	4
L05D @ 5 inH2O	14.0	15.0	16.0	mV	4
L10D @ 10 inH2O	19.0	20.0	21.0	mV	4
L20D @ 20 inH2O	19.0	20.0	21.0	mV	4
L30D @ 30 inH2O	19.0	20.0	21.0	mV	4
Span Temperature Shift (0°C to 50°C)	-	-	±250	uV	1
Offset Voltage @ Zero Diff. Pressure	-	-	±500	uV	-
Offset Temperature Shift (0°C to 50°C)					
L01D, L02D, L05D	-	-	±250	uV	1
L10D, L20D, L30D	-	-	±200	uV	1
Offset Warm-up Shift	-	-	±50.0	uV	2
Offset Position Sensitivity (1g)					
L01D	-	-	±20.0	uV	6
L02D	-	-	±15.0	uV	6
L05D, L10D, L20D, L30D	-	-	±10.0	uV	6
Offset Long Term Drift (One Year)					
L01D, L02D, L05D	-	±150	-	uV	-
L10D, L20D, L30D	-	±100	-	uV	-
Linearity, Hysteresis Error	-	0.10	0.30	%FSS	3
Response Time (10% to 90% Pressure Response)	-	500	-	us	-
Front to Back Linearity	-	0.75	-	%FSS	5
Input Resistance	-	12.0	-	k ohm	-
Output Resistance	-	3.0	-	k ohm	-

MLV Series Low Voltage Pressure Sensors

Performance Characteristics for MLV Series (PSI)

ALL PARAMETERS ARE MEASURED AT 5.0 VOLT EXCITATION AND ROOM TEMPERATURE UNLESS OTHERWISE SPECIFIED. PRESSURE MEASUREMENTS ARE WITH POSITIVE PRESSURE APPLIED TO PORT B (THE ONLY PORT FOR THE SINGLE PORT CONFIGURATION PACKAGES). PRESSURE IS APPLIED TO PORT A FOR ABSOLUTE DEVICES IN A-PACKAGE.

Parameter	Min	Typ	Max	Units	Notes
Output Span					
005D @ 5 PSI	24.75	25.0	25.25	mV	4
015D @ 15 PSI	37.13	37.50	37.88	mV	4
015A @ 15 PSIA	37.13	37.50	37.88	mV	4
030D @ 30 PSI	37.13	37.50	37.88	mV	4
100D @ 100 PSI	41.25	41.67	42.08	mV	4
150D @ 150 PSI	37.08	37.50	37.92	mV	4
Span Temperature Shift (0°C to 50°C)	-	-	±1.0	%FSS	1
Offset Voltage @ Zero Diff. Pressure					
005D @ 5 PSI	-	-	125	uV	-
015D @ 15 PSI	-	-	125	uV	-
015A @ 15 PSIA	-	-	208	uV	-
030D @ 30 PSI	-	-	125	uV	-
100D @ 100 PSI	-	-	125	uV	-
150D @ 150 PSI	-	-	125	uV	-
Offset Warm-Up Shift	-	±20		uV	2
Offset Long Term Drift (one year)	-	±100	-	uV	-
Linearity, Hysteresis Error	-	0.20	0.50	%FSS	3
Response Time (10% to 90% Pressure Response)	-	500	-	us	-
Front to Back Linearity	-	2.5	-	%FSS	5
Input Resistance	-	12.0	-	k ohm	-
Output Resistance	-	3.0	-	k ohm	-

Specification Notes

NOTE 1: SHIFT IS RELATIVE TO 25°C.

NOTE 2: SHIFT IS WITHIN THE FIRST HOUR OF EXCITATION APPLIED TO THE DEVICE.

NOTE 3: MEASURED AT ONE-HALF FULL SCALE RATED PRESSURE USING BEST STRAIGHT LINE CURVE FIT.

NOTE 4: THE SPAN IS THE ALGEBRAIC DIFFERENCE BETWEEN FULL SCALE OUTPUT VOLTAGE AND THE OFFSET VOLTAGE.

NOTE 5: FRONT-BACK LINEARITY COMPUTED AS:
$$\text{Lin}_{FB} = \left(\frac{\text{Span}_{\text{Front}}}{\text{Span}_{\text{Back}}} - 1 \right) \cdot 100\%$$

NOTE 6: PARAMETER IS CHARACTERIZED AND NOT 100% TESTED.

How To Order

A Package

Example: MLV-L02D-A6BBF-N

MLV- -A6 -

Pressure Range

Option	Description
L01D	1 in H2O
L02D	2 in H2O
L05D	5 in H2O
L10D	10 in H2O
L20D	20 in H2O
L30D	30 in H2O
005D	5 PSI
015D	15 PSI
015A	15 PSIA
030D	30 PSI
100D	100 PSI
150D	150 PSI

Port Cut Configuration

Option	Description
A	No Port Cut
B	Two Ports Cut 0.085"
C	Two Ports Cut 0.100"
D	Two Ports Cut 0.150"
E	One Port (A) Cut 0.080"
F	One Port (A) Cut 0.370"

Port Fittings

Option	Description
A	No Fittings
B	Barb Fitting Port A Only
C	Barb Fitting Port B Only
D	Barb Fittings Ports A & B

Coating

Option	Description
N	No Coating
P	Parylene Coating

(See NOTE 1 below)

Lead Configuration

Option	Description
F	Flat (Straight)
Q	Right Angle 0.075"
R	Right Angle 0.100"
J	Jogged Bend

E Package

Example: MLV-L02D-E1ND-N

MLV- -E -

Pressure Range

Option	Description
L01D	1 in H2O
L02D	2 in H2O
L05D	5 in H2O
L10D	10 in H2O
L20D	20 in H2O
L30D	30 in H2O
005D	5 PSI
015D	15 PSI
015A	15 PSIA
030D	30 PSI

Port Orientation

Option	Description
1	Dual Port Same Side
2	Dual Port Opposite Side
G	Single Port (Gage)

Lid Style

Option	Description
N	Non-Barbed
B	Barbed











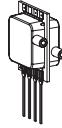

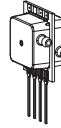

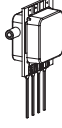
Coating

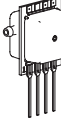
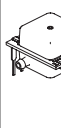
Option	Description
N	No Coating
P	Parylene Coating

Lead Type

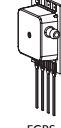
Option	Description
S	SIP
D	DIP
J	J-Lead SMT
L	Low Profile DIP

TABLE 1: Available E-Series Package Configurations

Port Orientation	Non-Barbed Lid Lead Style				Barbed Lid Lead Style			
	SIP	DIP	J Lead SMT	Low Profile DIP	SIP	DIP	J Lead SMT	Low Profile DIP
Dual Port Same Side				N/A			N/A	N/A
Dual Port Opposite Side				N/A			N/A	N/A
Single Port (Gage)								

NOTE 1) Parylene Coating: Parylene coating provides a moisture barrier and protection from some harsh media. Consult factory for applicability of Parylene for the target application and sensor type.

MLV Series Low Voltage Pressure Sensors

Package Drawings

A6 Package (Without Options)

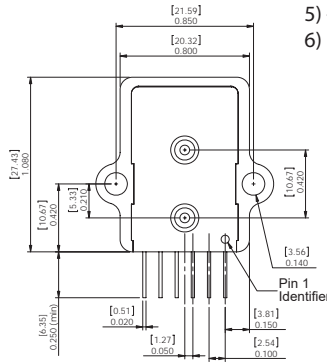
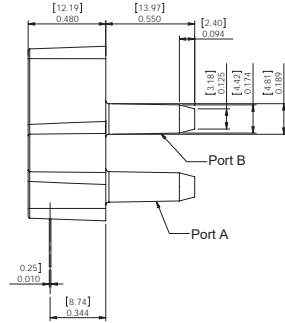
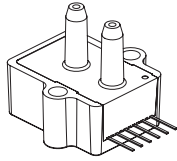

Pinout (Gage)	Pinout (Absolute)
1) N/C	1) N/C
2) Vs	2) Vs
3) +Out	3) -Out
4) Gnd	4) Gnd
5) -Out	5) +Out
6) N/C	6) N/C

NOTES
 1) Dimensions are in inches [mm].
 2) For suggested pad layout, see drawing: PAD-09

A-Package: Port Cut Options

Example: MLV-L10D-A6xAF-N

Port Cut Options

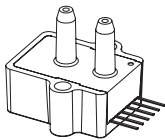

A- No Port Cut Configuration

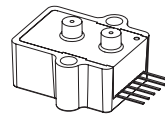
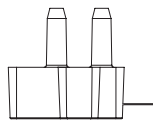

D- Two Ports Cut 0.150" Configuration

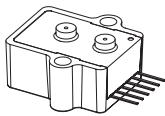
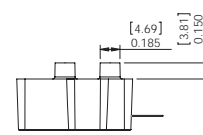

B- Two Ports Cut 0.085" Configuration

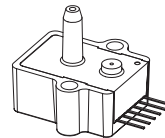
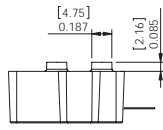

E- Port A cut 0.080" Configuration

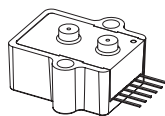
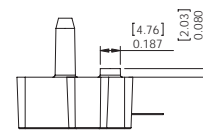

C- Two Ports Cut 0.100" Configuration

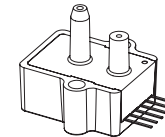
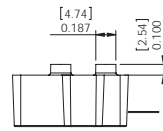

F- Port A Cut 0.370" Configuration

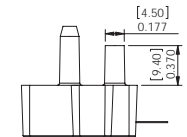

A-Package: Port Fitting Options

Example: MLV-L10D-A6DxF-N

Port Fitting Options

NOTE: Port Cut Configuration "D" Shown As Reference.

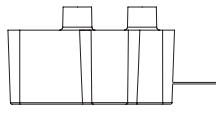
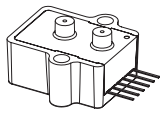

A- No Fittings Configuration

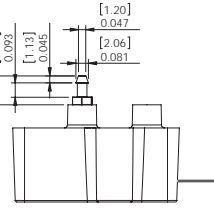
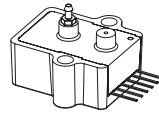

C- Barb Fitting Port B Only Configuration

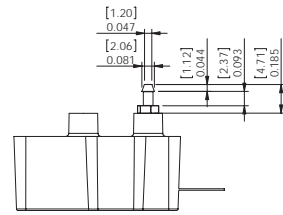
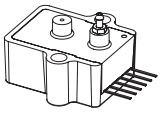

B- Barb Fitting Port A Only Configuration

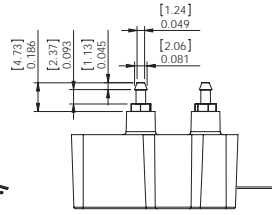
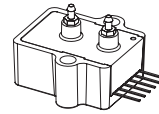

D- Barb Fitting Ports A and B Configuration

A-Package: Lead Bend Options

Example: MLV-L10D-A6AAx-N

Lead Bend Options

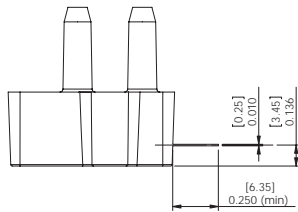
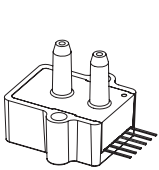

F- Flat (Straight) Configuration

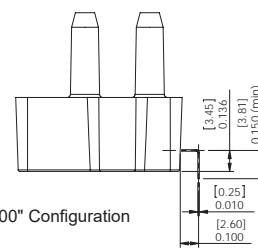
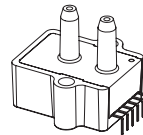

R- Right Angle 0.100" Configuration

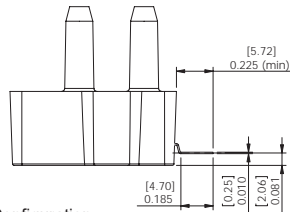
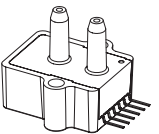

J- Jogged Bend Configuration

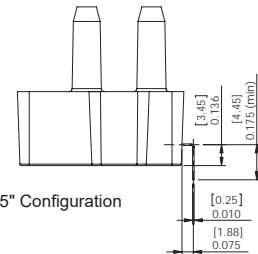
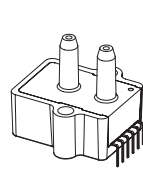

Q- Right Angle 0.075" Configuration

E1NS Package

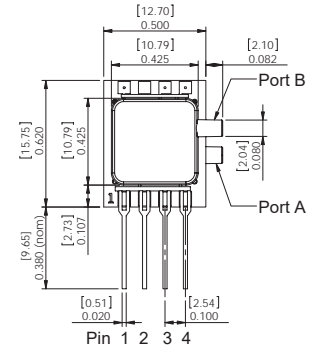
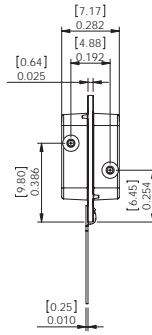
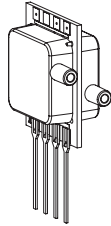

Pinout

- 1) Gnd
- 2) +Out
- 3) Vs
- 4) -Out

NOTES

- 1) Dimensions are in inches [mm]
- 2) For suggested pad layout, see drawing: PAD-01

E1BS Package

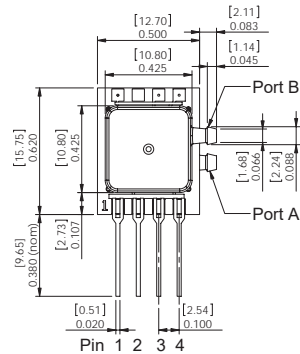
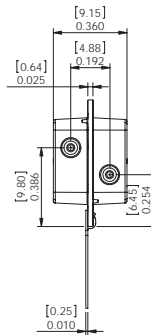
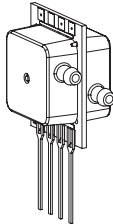

Pinout

- 1) Gnd
- 2) +Out
- 3) Vs
- 4) -Out

NOTES

- 1) Dimensions are in inches [mm]
- 2) For suggested pad layout, see drawing: PAD-01

E2NS Package

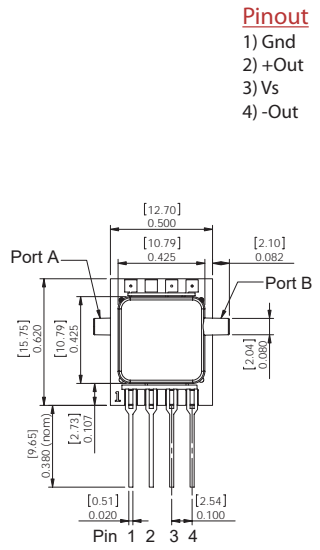
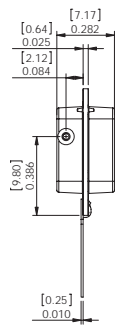
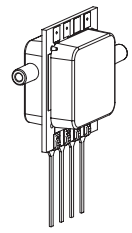

- Pinout**
- 1) Gnd
 - 2) +Out
 - 3) Vs
 - 4) -Out

NOTES
 1) Dimensions are in inches [mm]
 2) For suggested pad layout, see drawing: PAD-01

E2BS Package

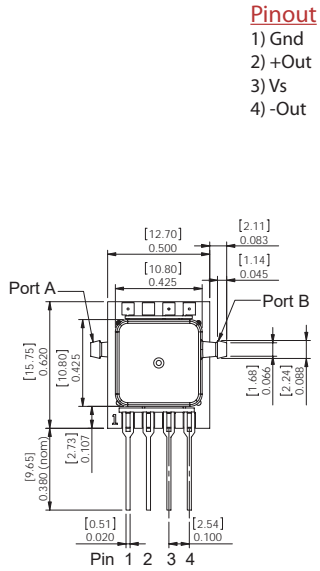
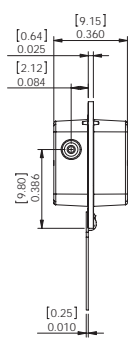
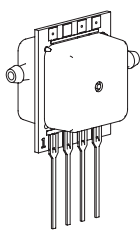

- Pinout**
- 1) Gnd
 - 2) +Out
 - 3) Vs
 - 4) -Out

NOTES
 1) Dimensions are in inches [mm]
 2) For suggested pad layout, see drawing: PAD-01

EGNS Package

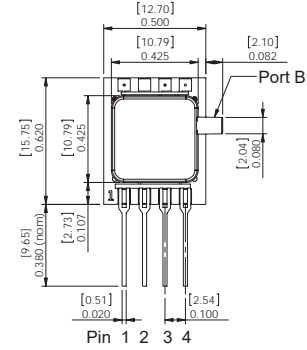
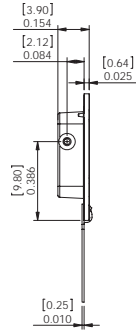
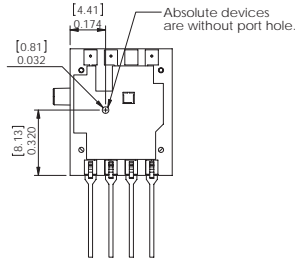
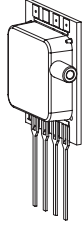

Pinout

- 1) Gnd
- 2) +Out
- 3) Vs
- 4) -Out

NOTES

- 1) Dimensions are in inches [mm]
- 2) For suggested pad layout, see drawing: PAD-01

EGBS Package

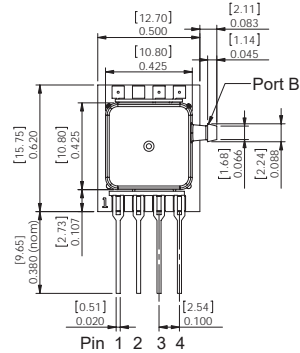
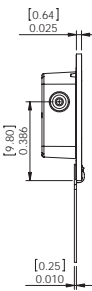
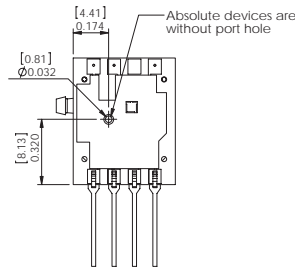
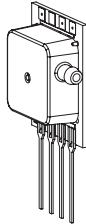

Pinout

- 1) Gnd
- 2) +Out
- 3) Vs
- 4) -Out

NOTES

- 1) Dimensions are in inches [mm]
- 2) For suggested pad layout, see drawing: PAD-01

E1ND Package

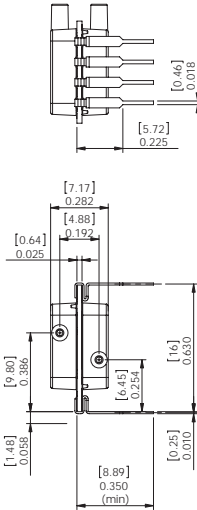
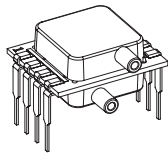

Pinout

- 1) Gnd
- 2) +Out
- 3) Vs
- 4) -Out
- 5) Do Not Connect
- 6) Do Not Connect
- 7) Do Not Connect
- 8) Do Not Connect

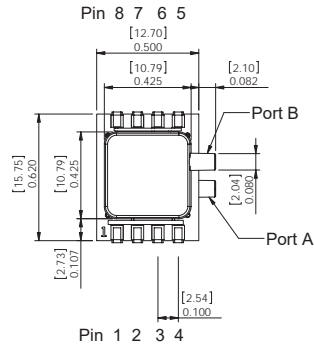

NOTES

- 1) Dimensions are in inches [mm]
- 2) For suggested pad layout, see drawing: PAD-03

E1BD Package

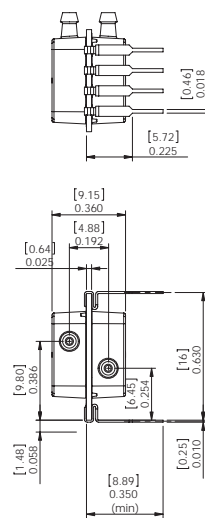
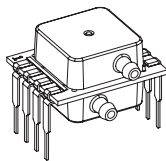

Pinout

- 1) Gnd
- 2) +Out
- 3) Vs
- 4) -Out
- 5) Do Not Connect
- 6) Do Not Connect
- 7) Do Not Connect
- 8) Do Not Connect

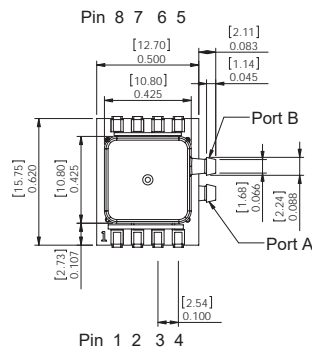

NOTES

- 1) Dimensions are in inches [mm]
- 2) For suggested pad layout, see drawing: PAD-03

E2ND Package

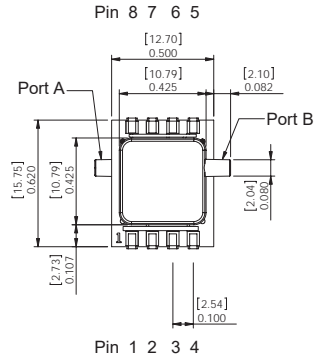
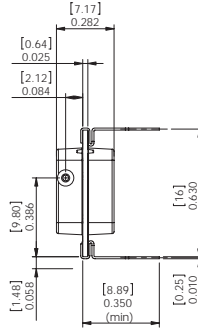
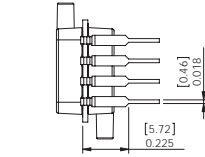
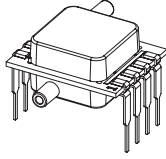

Pinout

- 1) Gnd
- 2) +Out
- 3) Vs
- 4) -Out
- 5) Do Not Connect
- 6) Do Not Connect
- 7) Do Not Connect
- 8) Do Not Connect

NOTES

- 1) Dimensions are in inches [mm]
- 2) For suggested pad layout, see drawing: PAD-03

E2BD Package

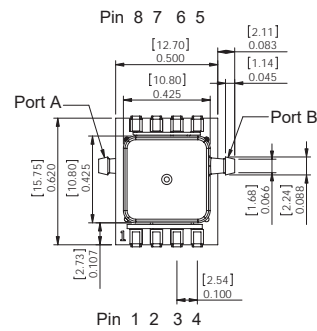
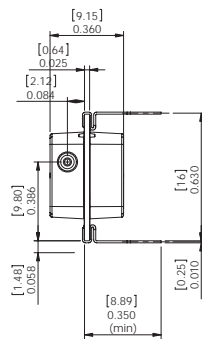
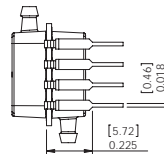
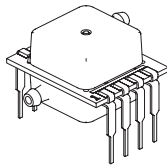

Pinout

- 1) Gnd
- 2) +Out
- 3) Vs
- 4) -Out
- 5) Do Not Connect
- 6) Do Not Connect
- 7) Do Not Connect
- 8) Do Not Connect

NOTES

- 1) Dimensions are in inches [mm]
- 2) For suggested pad layout, see drawing: PAD-03

EGND Package

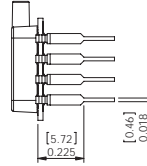
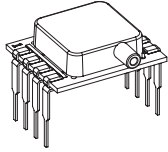

Pinout

- 1) Gnd
- 2) +Out
- 3) Vs
- 4) -Out
- 5) Do Not Connect
- 6) Do Not Connect
- 7) Do Not Connect
- 8) Do Not Connect

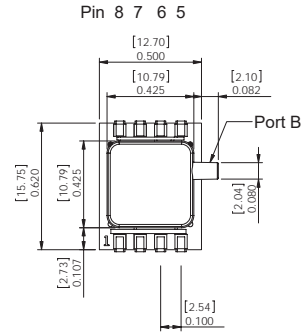
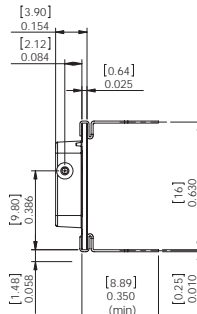
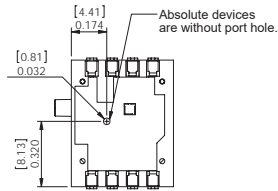

NOTES

- 1) Dimensions are in inches [mm]
- 2) For suggested pad layout, see drawing: PAD-03

EGBD Package

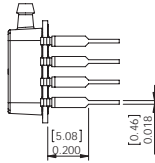
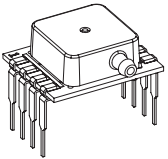

Pinout

- 1) Gnd
- 2) +Out
- 3) Vs
- 4) -Out
- 5) Do Not Connect
- 6) Do Not Connect
- 7) Do Not Connect
- 8) Do Not Connect

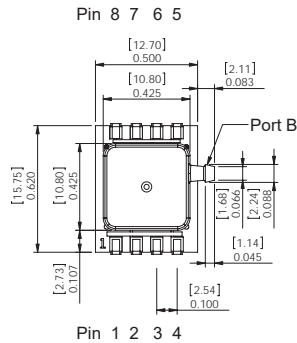
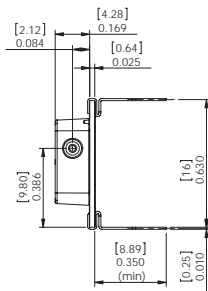
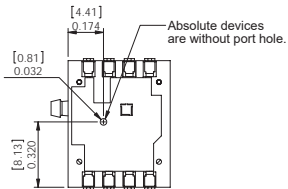

NOTES

- 1) Dimensions are in inches [mm]
- 2) For suggested pad layout, see drawing: PAD-03

E1NJ Package

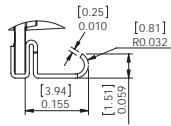
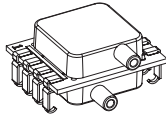

DETAIL A
SCALE 4 : 1

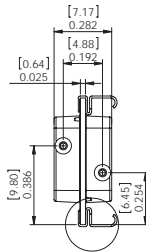

A

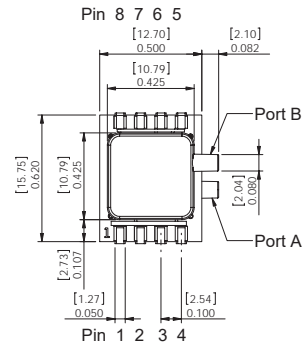

Pinout

- 1) Gnd
- 2) +Out
- 3) Vs
- 4) -Out
- 5) Do Not Connect
- 6) Do Not Connect
- 7) Do Not Connect
- 8) Do Not Connect

NOTES

- 1) Dimensions are in inches [mm]
- 2) For suggested pad layout, see drawing: PAD-10

E2NJ Package

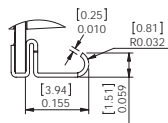
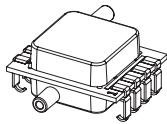

DETAIL A
SCALE 4 : 1

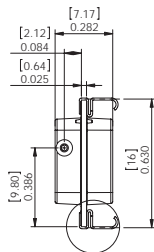

A

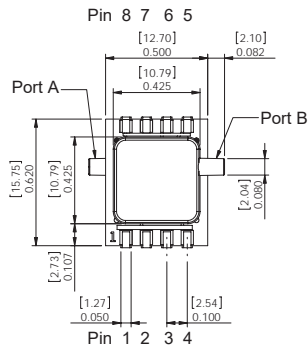

Pinout

- 1) Gnd
- 2) +Out
- 3) Vs
- 4) -Out
- 5) Do Not Connect
- 6) Do Not Connect
- 7) Do Not Connect
- 8) Do Not Connect

NOTES

- 1) Dimensions are in inches [mm]
- 2) For suggested pad layout, see drawing: PAD-10

EGNJ Package

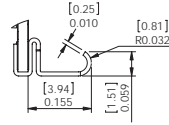
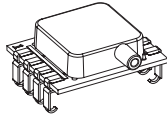

Pinout

- 1) Gnd
- 2) +Out
- 3) Vs
- 4) -Out
- 5) Do Not Connect
- 6) Do Not Connect
- 7) Do Not Connect
- 8) Do Not Connect

DETAIL A
 SCALE 4 : 1

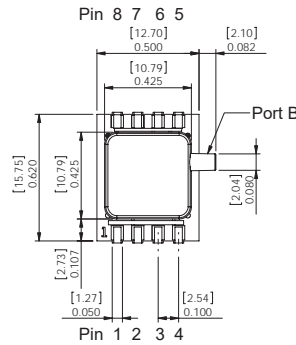
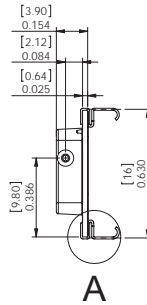
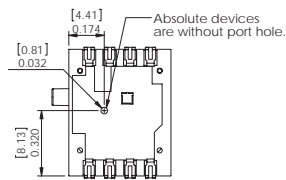

NOTES

- 1) Dimensions are in inches [mm]
- 2) For suggested pad layout, see drawing: PAD-10

EGBJ Package

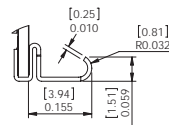
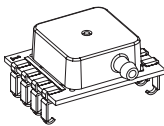

Pinout

- 1) Gnd
- 2) +Out
- 3) Vs
- 4) -Out
- 5) Do Not Connect
- 6) Do Not Connect
- 7) Do Not Connect
- 8) Do Not Connect

DETAIL A
 SCALE 4 : 1

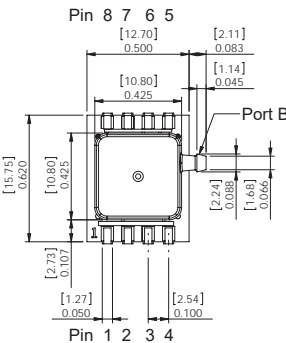
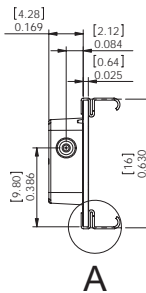
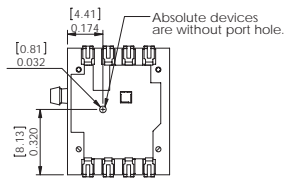

NOTES

- 1) Dimensions are in inches [mm]
- 2) For suggested pad layout, see drawing: PAD-10

EGNL Package

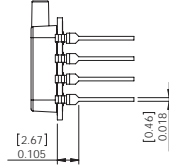
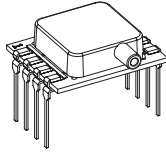

Pinout

- 1) Gnd
- 2) +Out
- 3) Vs
- 4) -Out
- 5) Do Not Connect
- 6) Do Not Connect
- 7) Do Not Connect
- 8) Do Not Connect

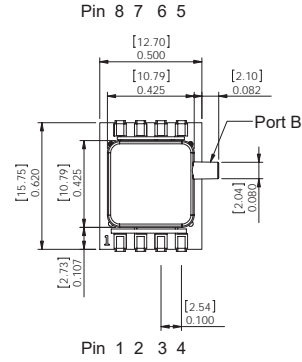
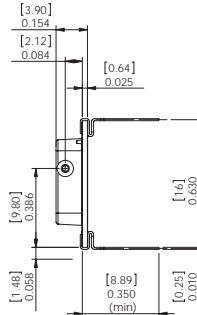
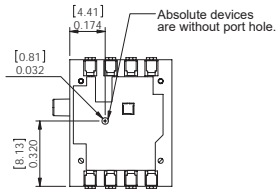

NOTES

- 1) Dimensions are in inches [mm]
- 2) For suggested pad layout, see drawing: PAD-03

EGBL Package

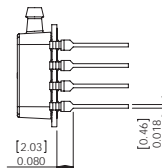
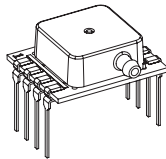

Pinout

- 1) Gnd
- 2) +Out
- 3) Vs
- 4) -Out
- 5) Do Not Connect
- 6) Do Not Connect
- 7) Do Not Connect
- 8) Do Not Connect

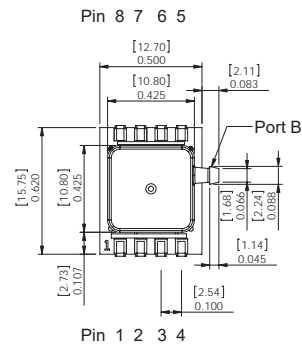
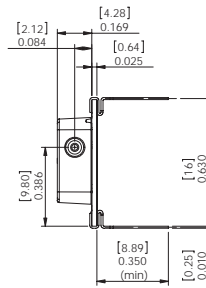
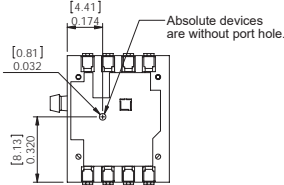

NOTES

- 1) Dimensions are in inches [mm]
- 2) For suggested pad layout, see drawing: PAD-03

Suggested Pad Layout

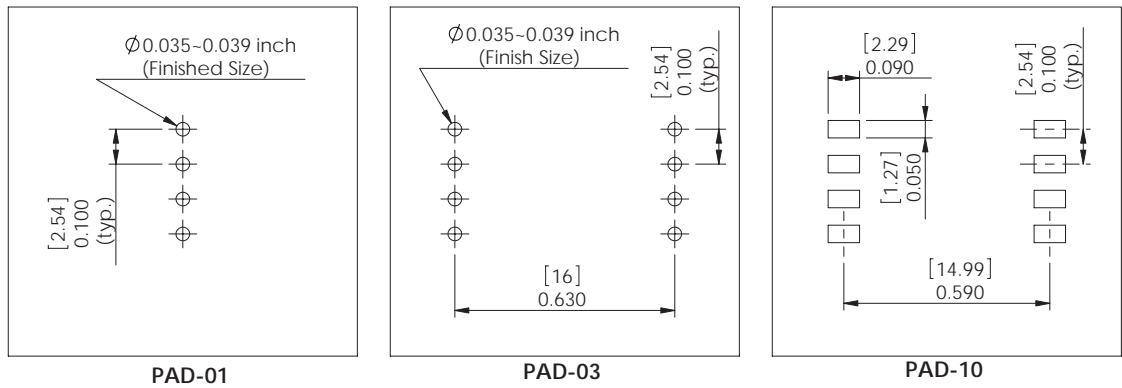

Package Characteristics

Package ID	Approximate Port Volume				Weight	Units	Notes
	Port A	Port B	Units	Notes			
A6AAx	132	33.6	mm ³	1	9.3	Grams	2
A6BAx	119	20.3	mm ³	1	8.7	Grams	2
A6CAx	119	20.5	mm ³	1	8.8	Grams	2
A6DAx	120	21.3	mm ³	1	8.8	Grams	2
A6EAx	119	33.6	mm ³	1	8.9	Grams	2
A6FAx	125	33.6	mm ³	1	9.2	Grams	2
E1Nx	174	168	mm ³	-	1.2	Grams	-
E2Nx	174	168	mm ³	-	1.2	Grams	-
EGNx	1.4	168	mm ³	-	0.9	Grams	-

Package Notes

Note 1: Add 4.5 mm³ per port with barb fitting.

Note 2: Add 0.15 gram per barb fitting.

Product Labeling

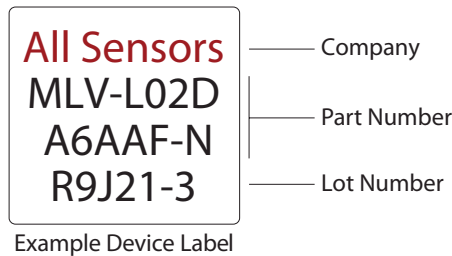

* 5 PSI to 150 PSI devices may not be assembled with CoBeam²™ Technology.

All Sensors reserves the right to make changes to any products herein. All Sensors does not assume any liability arising out of the application or use of any product or circuit described herein, neither does it convey any license under its patent rights nor the rights of others.

MLV Series Low Voltage Pressure Sensors

Millivolt Output Pressure Sensors

C-Grade
Pressure Sensors



Features

- 0 to 0.3 PSI to 0 to 100 PSI Pressure Ranges
- 1 % linearity version
- Temperature Compensated
- Calibrated Zero and Span

Applications

- Medical Instrumentation
- Environmental Controls
- HVAC

General Description

The Millivolt Output pressure sensors is based upon a proprietary packaging technology to reduce output offset or common mode errors. This model provides a calibrated millivolt output with good output offset characteristics. In addition the sensor utilizes a silicon, micromachined, stress concentration enhanced structure to provide a very linear output to measured pressure.

These calibrated and temperature compensated sensors give an accurate and stable output over a wide temperature range. This series is intended for use with non-corrosive, non-ionic working fluids such as air, dry gases and the like. The C-GRADE is a lowest cost version of the millivolt output pressure sensors.

The output of the device is ratiometric to the supply voltage and operation from any D.C. supply voltage up to +16 V is acceptable.

Physical Dimensions

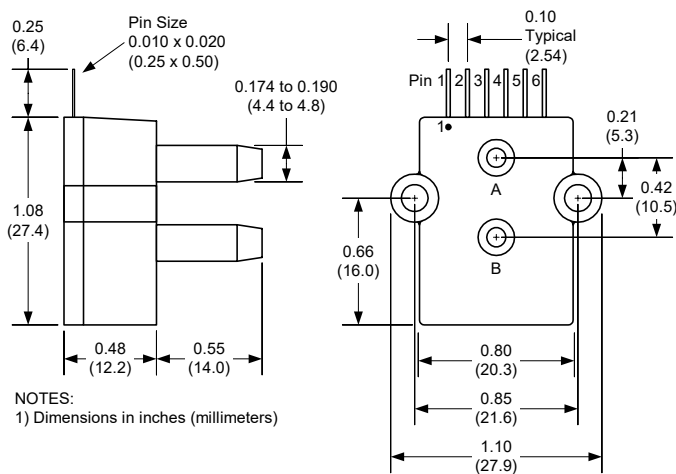

- pin 1: N/C
- pin 2: +V supply
- pin 3: +Voutput
- pin 4: -Vsupply
- pin 5: -Voutput
- pin 6: N/C



Pressure Sensor Characteristics Maximum Ratings

Supply Voltage ,Vs	16 Vdc
Common-mode pressure	50 psig
Lead Temperature (soldering 2-4 sec.)	250°C

Environmental Specifications

Temperature Ranges	
Compensated	0 to 70° C
Operating	-25 to 85° C
Storage	-40 to 125° C
Humidity Limits	0 to 95% RH (non condensing)

Standard Pressure Ranges

Part Number	Operating Pressure	Nominal Span	Proof Pressure	Burst Pressure
4 INCH-D-CGRADE-MV	0 - 4 "H2O	40 mV	1 PSI	5 PSI
0.3 PSI-D-CGRADE-MV	0 - 0.3 PSI	20 mV	5 PSI	5 PSI
1 PSI-D-CGRADE-MV	0 - 1 PSI	18 mV	5 PSI	15 PSI
5 PSI-D-CGRADE-MV	0 - 5 PSI	60 mV	10 PSI	30 PSI
15 PSI-D-CGRADE-MV	0 - 15 PSI	90 mV	60 PSI	120 PSI
30 PSI-D-CGRADE-MV	0 - 30 PSI	90 mV	90 PSI	150 PSI
100 PSI-D-CGRADE-MV	0 - 100 PSI	100mV	200 PSI	250 PSI
150 PSI-D-CGRADE-MV	0 - 150 PSI	90mV	200 PSI	250 PSI
15 PSI-A-CGRADE-MV	0 - 15 PSIA	60mV	60 PSIA	120 PSI

Performance Characteristics for 4 INCH-D-CGRADE-MV

Parameter, note 1	Minimum	Nominal	Maximum	Units
Operating Range, differential pressure		4.0		"H2O
Output Span, note 5	38	40.0	42	mV
Offset Voltage @ zero differential pressure			±1.5	mV
Offset Temperature Shift (0°C-50°C), note 2			±1.5	mV
Linearity, hysteresis error, note 4		0.5	1.0	%fs
Span Shift (0°C-50°C), note 2			±2	%fs

Performance Characteristics for 0.3 PSI-D-CGRADE-MV

Parameter, note 1	Minimum	Nominal	Maximum	Units
Operating Range, differential pressure		0.3		PSI
Output Span, note 5	18	20.0	22	mV
Offset Voltage @ zero differential pressure			±1	mV
Offset Temperature Shift (0°C-70°C), note 2			±1	mV
Linearity, hysteresis error, note 4		0.5	1	%fs
Span Shift (0°C-70°C), note 2			±2	%fs

Performance Characteristics for 1 PSI-D-CGRADE-MV

Parameter, note 1	Minimum	Nominal	Maximum	Units
Operating Range, differential pressure		1.0		PSI
Output Span, note 5	16	18	20	mV
Offset Voltage @ zero differential pressure			±1	mV
Offset Temperature Shift (0°C-70°C), note 2			±1	mV
Linearity, hysteresis error, note 4		0.5	1.0	%fs
Span Shift (0°C-70°C), note 2			±2	%fs

Performance Characteristics for 5 PSI-D-CGRADE-MV

Parameter, note 1	Minimum	Nominal	Maximum	Units
Operating Range, differential pressure		5.0		PSI
Output Span, note 5	57	60	63	mV
Offset Voltage @ zero differential pressure			±1	mV
Offset Temperature Shift (0°C-70°C), note 2			±1	mV
Linearity, hysteresis error, note 4		0.5	1.0	%fs
Span Shift (0°C-70°C), note 2			±2	%fs

Performance Characteristics for 15 PSI-D-CGRADE-MV

Parameter, note 1	Minimum	Nominal	Maximum	Units
Operating Range, differential pressure		15.0		PSI
Output Span, note 5	86	90.0	94	mV
Offset Voltage @ zero differential pressure			±1	mV
Offset Temperature Shift (0°C-70°C), note 2			±1	mV
Linearity, hysteresis error, note 4		0.5	1.0	%fs
Span Shift (0°C-70°C), note 2			±2	%fs

Performance Characteristics for 30 PSI-D-CGRADE-MV

Parameter, note 1	Minimum	Nominal	Maximum	Units
Operating Range, differential pressure		30.0		PSI
Output Span, note 5	86	90	94	mV
Offset Voltage @ zero differential pressure			±1	mV
Offset Temperature Shift (0°C-70°C), note 2			±1	mV
Linearity, hysteresis error, note 4		0.5	1.0	%fs
Span Shift (0°C-70°C), note 2			±2	%fs



Performance Characteristics for 100 PSI-D-CGRADE-MV

Parameter, note 1	Minimum	Nominal	Maximum	Units
Operating Range, differential pressure		100.0		PSI
Output Span, note 5	96	100	104	mV
Offset Voltage @ zero differential pressure			±1	mV
Offset Temperature Shift (0°C-70°C), note 2			±1	mV
Linearity, hysteresis error, note 4		0.5	1.0	%fs
Span Shift (0°C-70°C), note 2			±2	%fs

Performance Characteristics for 150 PSI-D-CGRADE-MV

Parameter, note 1	Minimum	Nominal	Maximum	Units
Operating Range, differential pressure		150.0		PSI
Output Span, note 5	86	90	95	mV
Offset Voltage @ zero differential pressure			±1	mV
Offset Temperature Shift (0°C-70°C), note 2			±1	mV
Linearity, hysteresis error, note 4		0.5	1.0	%fs
Span Shift (0°C-70°C), note 2			±2	%fs

Performance Characteristics for 15 PSI-A-CGRADE-MV

Parameter, note 1	Minimum	Nominal	Maximum	Units
Operating Range, absolute pressure		15.0		PSIA
Output Span, note 5	86	90.0	94	mV
Offset Voltage @ zero absolute pressure			±1	mV
Offset Temperature Shift (0°C-70°C), note 2			±1	mV
Linearity, hysteresis error, note 4		0.5	1.0	%fs
Span Shift (0°C-70°C), note 2			±2	%fs

Specification Notes

NOTE 1: ALL PARAMETERS ARE MEASURED AT 12.0 VOLT EXCITATION, FOR THE NOMINAL FULL SCALE PRESSURE AND ROOM TEMPERATURE UNLESS OTHERWISE SPECIFIED. PRESSURE MEASUREMENTS ARE WITH POSITIVE PRESSURE APPLIED TO PORT B.

NOTE 2: SHIFT IS RELATIVE TO 25°C.

NOTE 3: SHIFT IS WITHIN THE FIRST HOUR OF EXCITATION APPLIED TO THE DEVICE.

NOTE 4: MEASURED AT ONE-HALF FULL SCALE RATED PRESSURE USING BEST STRAIGHT LINE CURVE FIT.

NOTE 5: THE VOLTAGE ADDED TO THE OFFSET VOLTAGE AT FULL SCALE PRESSURE.

Input Resistance 5.0 k ohm
 Output Resistance 3.0 k ohm

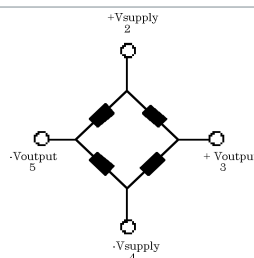

Equivalent Circuit

All Sensors reserves the right to make changes to any products herein. All Sensors does not assume any liability arising out of the application or use of any product or circuit described herein, neither does it convey any license under its patent rights nor the rights of others.

MILLIVOLT OUTPUT PRESSURE SENSORS

H-Grade
Pressure Sensors

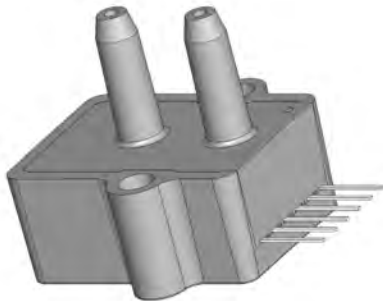

Features

- 0 to 4" H₂O to 0 to 100 PSI Pressure Ranges
- 0.5 % linearity...high accuracy version
- Temperature Compensated
- Calibrated Zero and Span

Applications

- Medical Instrumentation
- Environmental Controls
- HVAC

General Description

The Millivolt Output pressure sensors is based upon a proprietary packaging technology to reduce output offset or common mode errors. This model provides a calibrated millivolt output with excellent output offset characteristics. In addition the sensor utilizes a silicon, micromachined, stress concentration enhanced structure to provide a very linear output to measured pressure.

These calibrated and temperature compensated sensors give an accurate and stable output over a wide temperature range. This series is intended for use with non-corrosive, non-ionic working fluids such as air, dry gases and the like. The H-GRADE is a high accuracy version of the millivolt output pressure sensors.

The output of the device is ratiometric to the supply voltage and operation from any D.C. supply voltage up to +16 V is acceptable.

Physical Dimensions

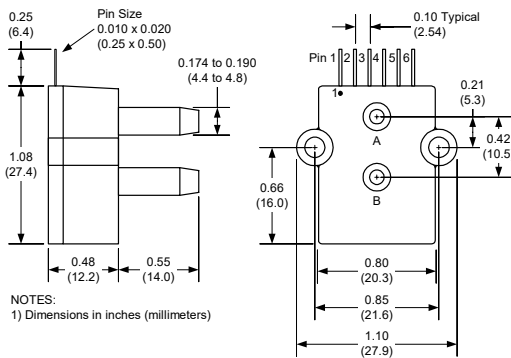

Equivalent Circuit

- Pinout (note 1)**
- pin 1: N/C
 - pin 2: +V supply
 - pin 3: +V output
 - pin 4: -V supply
 - pin 5: -V output
 - pin 6: N/C

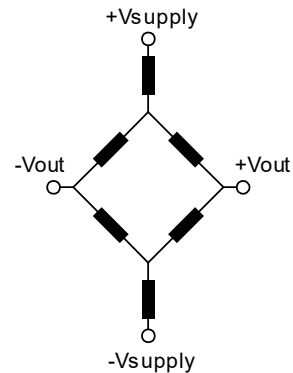

Input Resistance 20 k ohm
Output Resistance 3.0 k ohm

Approvals

MKT	DATE	MFG	DATE	ENG	DATE	QA	DATE
<input type="checkbox"/> As Is <input type="checkbox"/> With Change		<input type="checkbox"/> As Is <input type="checkbox"/> With Change		<input type="checkbox"/> As Is <input type="checkbox"/> With Change		<input type="checkbox"/> As Is <input type="checkbox"/> With Change	

ALL SENSORS

DS-0095 Rev C

Pressure Sensor Characteristics Maximum Ratings

Supply Voltage, Vs	16 Vdc
Common-mode pressure	50 psig
Lead Temperature (soldering 2-4 sec.)	250°C

Environmental Specifications

Temperature Ranges	
Compensated	0 to 70° C
Operating	-25 to 85° C
Storage	-40 to 125° C
Humidity Limits	0 to 95% RH (non condensing)

Standard Pressure Ranges

Part Number	Operating Pressure	Nominal Span	Proof Pressure	Burst Pressure
4 INCH-D-HGRADE-MV	0 - 4" H2O	40 mV	3 PSI	15 PSI
0.3 PSI-D-HGRADE-MV	0 - 0.3 PSI	20 mV	5 PSI	15 PSI
1 PSI-D-HGRADE-MV	0 - 1 PSI	18 mV	5 PSI	15 PSI
5 PSI-D-HGRADE-MV	0 - 5 PSI	60 mV	10 PSI	30 PSI
15 PSI-D-HGRADE-MV	0 - 15 PSI	90 mV	60 PSI	120 PSI
30 PSI-D-HGRADE-MV	0 - 30 PSI	90 mV	90 PSI	150 PSI
100 PSI-D-HGRADE-MV	0 - 100 PSI	100 mV	200 PSI	250 PSI
150 PSI-D-HGRADE-MV	0 - 150 PSI	90 mV	200 PSI	250 PSI
15 PSI-A-HGRADE-MV	0 - 15 PSIA	90 mV	60 PSIA	120 PSIA
30 PSI-A-HGRADE-MV	0 - 30 PSIA	90 mV	90 PSIA	150 PSIA
100 PSI-A-HGRADE-MV	0 - 100 PSIA	100 mV	200 PSIA	250 PSIA

Performance Characteristics for 4 INCH-D-HGRADE-MV

Parameter, note 1	Minimum	Nominal	Maximum	Units
Operating Range, differential pressure	--	4	--	"H2O
Output Span, note 5	39.5	40.0	40.5	mV
Offset Voltage @ zero differential pressure	--	--	±0.5	mV
Offset Temperature Shift (0°C-70°C), note 2	--	--	±500	uV
Linearity, hysteresis error, note 4	--	0.25	0.5	%fs
Span Shift (0°C-70°C), note 2	--	--	±1	%fs

Performance Characteristics for 0.3 PSI-D-HGRADE-MV

Parameter, note 1	Minimum	Nominal	Maximum	Units
Operating Range, differential pressure	--	0.3	--	PSI
Output Span, note 5	19.8	20.0	20.2	mV
Offset Voltage @ zero differential pressure	--	--	±0.3	mV
Offset Temperature Shift (0°C-70°C), note 2	--	--	±500	uV
Linearity, hysteresis error, note 4	--	0.25	0.5	%fs
Span Shift (0°C-70°C), note 2	--	--	±1	%fs

MILLIVOLT H-GRADE PRESSURE SENSORS

Performance Characteristics for 100 PSI-D-HGRADE-MV

Parameter, note 1	Minimum	Nominal	Maximum	Units
Operating Range, differential pressure	--	100.0	--	PSI
Output Span, note 5	99	100	101	mV
Offset Voltage @ zero differential pressure	--	--	±0.3	mV
Offset Temperature Shift (0°C-70°C), note 2	--	--	±500	uV
Linearity, hysteresis error, note 4	--	0.25	0.5	%fs
Span Shift (0°C-70°C), note 2	--	--	±1	%fs

Performance Characteristics for 150 PSI-D-HGRADE-MV

Parameter, note 1	Minimum	Nominal	Maximum	Units
Operating Range, differential pressure	--	150.0	--	PSI
Output Span, note 5	89	90	91	mV
Offset Voltage @ zero differential pressure	--	--	±0.3	mV
Offset Temperature Shift (0°C-70°C), note 2	--	--	±500	uV
Linearity, hysteresis error, note 4	--	0.25	0.5	%fs
Span Shift (0°C-70°C), note 2	--	--	±1	%fs

Performance Characteristics for 15 PSI-A-HGRADE-MV

Parameter, note 1	Minimum	Nominal	Maximum	Units
Operating Range, absolute pressure	--	15.0	--	PSIA
Output Span, note 5	89.1	90.0	90.9	mV
Offset Voltage @ zero absolute pressure	--	--	±0.5	mV
Offset Temperature Shift (0°C-70°C), note 2	--	--	±500	uV
Linearity, hysteresis error, note 4	--	0.25	0.5	%fs
Span Shift (0°C-70°C), note 2	--	--	±1	%fs

Performance Characteristics for 30 PSI-A-HGRADE-MV

Parameter, note 1	Minimum	Nominal	Maximum	Units
Operating Range, absolute pressure	--	30.0	--	PSIA
Output Span, note 5	89.1	90.0	90.9	mV
Offset Voltage @ zero absolute pressure	--	--	±0.5	mV
Offset Temperature Shift (0°C-70°C), note 2	--	--	±500	uV
Linearity, hysteresis error, note 4	--	0.25	0.5	%fs
Span Shift (0°C-70°C), note 2	--	--	±1	%fs

Performance Characteristics for 100 PSI-A-HGRADE-MV

Parameter, note 1	Minimum	Nominal	Maximum	Units
Operating Range, absolute pressure	--	100.0	--	PSIA
Output Span, note 5	99.0	100.0	101.0	mV
Offset Voltage @ zero absolute pressure	--	--	±0.5	mV
Offset Temperature Shift (0°C-70°C), note 2	--	--	±500	uV
Linearity, hysteresis error, note 4	--	0.25	0.5	%fs
Span Shift (0°C-70°C), note 2	--	--	±1	%fs

Specification Notes

NOTE 1: ALL PARAMETERS ARE MEASURED AT 12.0 VOLT EXCITATION, FOR THE NOMINAL FULL SCALE PRESSURE AND ROOM TEMPERATURE UNLESS OTHERWISE SPECIFIED. PRESSURE MEASUREMENTS ARE WITH POSITIVE PRESSURE APPLIED TO PORT B. FOR ABSOLUTE DEVICES PRESSURE IS APPLIED TO PORT A, AND THE OUTPUT POLARITY IS REVERSED.

NOTE 2: SHIFT IS RELATIVE TO 25°C.

NOTE 3: SHIFT IS WITHIN THE FIRST HOUR OF EXCITATION APPLIED TO THE DEVICE.

NOTE 4: MEASURED AT ONE-HALF FULL SCALE RATED PRESSURE USING BEST STRAIGHT LINE CURVE FIT.

NOTE 5: THE VOLTAGE ADDED TO THE OFFSET VOLTAGE AT FULL SCALE PRESSURE.

All Sensors reserves the right to make changes to any products herein. All Sensors does not assume any liability arising out of the application or use of any product or circuit described herein, neither does it convey any license under its patent rights nor the rights of others.

Millivolt Output Pressure Sensors

Prime Grade Pressure Sensors

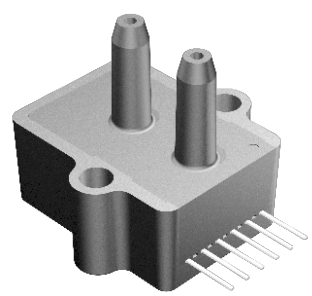

Features

- 0 to 0.3 PSI to 0 to 150 PSI Pressure Ranges
- Highest accuracy version
- Temperature Compensated
- Calibrated Zero and Span

Applications

- Medical Instrumentation
- Environmental Controls
- HVAC

General Description

The Millivolt Output pressure sensor is based upon a proprietary packaging technology to reduce output offset or common mode errors. This model provides a calibrated millivolt output with excellent output offset characteristics. In addition the sensor utilizes a silicon, micromachined, stress concentration enhanced structure to provide a very linear output to measured pressure.

These calibrated and temperature compensated sensors give an accurate and stable output over a wide temperature range. This series is intended for use with non-corrosive, non-ionic working fluids such as air, dry gases and the like. The PRIME GRADE is the highest accuracy version of the millivolt output pressure sensors.

The output of the device is ratiometric to the supply voltage and operation from any D.C. supply voltage up to +16 V is acceptable.

Physical Dimensions

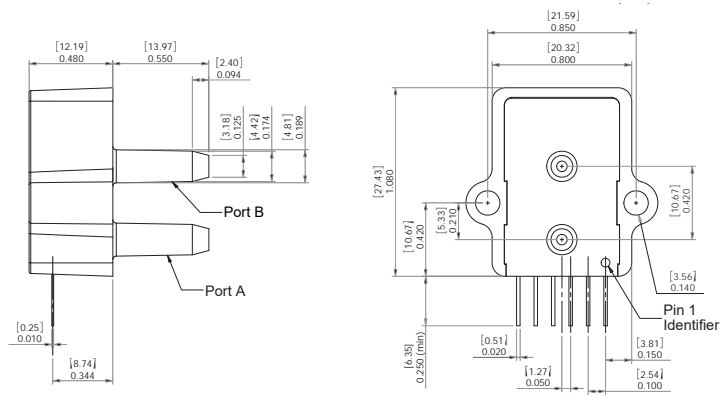

- pin 1: N/C
- pin 2: +V supply
- pin 3: +Voutput
- pin 4: -Vsupply
- pin 5: -Voutput
- pin 6: N/C

Approvals

MKT	DATE	MFG	DATE	ENG	DATE	QA	DATE
<input type="checkbox"/> As Is <input type="checkbox"/> With Change		<input type="checkbox"/> As Is <input type="checkbox"/> With Change		<input type="checkbox"/> As Is <input type="checkbox"/> With Change		<input type="checkbox"/> As Is <input type="checkbox"/> With Change	

All Sensors

DS-0096 Rev B

Pressure Sensor Characteristics Maximum Ratings

Supply Voltage VS	16 Vdc
Common-mode pressure	50 psig
Lead Temperature (soldering 2-4 sec.)	270°C

Environmental Specifications

Temperature Ranges	
Compensated	0 to 70° C
Operating	-25 to 85° C
Storage	-40 to 125° C
Humidity Limits	0 to 95% RH (non condensing)

Standard Pressure Ranges

Part Number	Operating Pressure	Nominal Span	Proof Pressure	Burst Pressure
0.3 PSI-D-PRIME-MV	0 - 0.3 PSI	20 mV	5 PSI	15 PSI
1 PSI-D-PRIME-MV	0 - 1 PSI	18 mV	5 PSI	15 PSI
5 PSI-D-PRIME-MV	0 - 5 PSI	60 mV	10 PSI	30 PSI
15 PSI-D-PRIME-MV	0 - 15 PSI	90 mV	60 PSI	120 PSI
15 PSI-A-PRIME-MV	0 - 15 PSIA	90 mV	60 PSIA	120 PSIA
30 PSI-D-PRIME-MV	0 - 30 PSI	90 mV	90 PSI	150 PSI
30 PSI-A-PRIME-MV	0 - 30 PSIA	90 mV	90 PSIA	150 PSIA
100 PSI-D-PRIME-MV	0 - 100 PSI	100 mV	200 PSI	250 PSI
100 PSI-A-PRIME-MV	0 - 100 PSIA	100 mV	200 PSIA	250 PSIA
150 PSI-D-PRIME-MV	0 - 150 PSI	90 mV	200 PSI	250 PSI

Performance Characteristics for 0.3 PSI-D-PRIME-MV

Parameter, note 1	Minimum	Nominal	Maximum	Units
Output Span, note 4	19.8	20.0	20.2	mV
Offset Voltage @ zero differential pressure	-	-	±0.3	mV
Offset Temperature Shift (0°C-70°C), note 2	-	-	±250	uV
Linearity, hysteresis error, note 3	-	0.1	0.25	%FSS
Span Temperature Shift (0°C-70°C), note 2	-	-	±1.0	%FSS

Performance Characteristics for 1 PSI-D-PRIME-MV

Parameter, note 1	Minimum	Nominal	Maximum	Units
Output Span, note 4	17.82	18.0	18.18	mV
Offset Voltage @ zero differential pressure	-	-	±0.3	mV
Offset Temperature Shift (0°C-70°C), note 2	-	-	±250	uV
Linearity, hysteresis error, note 3	-	0.1	0.25	%FSS
Span Temperature Shift (0°C-70°C), note 2	-	-	±1.0	%FSS

millivolt output prime grade pressure sensors

Performance Characteristics for 5 PSI-D-PRIME-MV

Parameter, note 1	Minimum	Nominal	Maximum	Units
Output Span, note 4	59.4	60.0	60.6	mV
Offset Voltage @ zero differential pressure	-	-	±0.3	mV
Offset Temperature Shift (0°C-70°C), note 2	-	-	±250	uV
Linearity, hysteresis error, note 3	-	0.1	0.25	%FSS
Span Temperature Shift (0°C-70°C), note 2	-	-	±1.0	%FSS

Performance Characteristics for 15 PSI-D-PRIME-MV

Parameter, note 1	Minimum	Nominal	Maximum	Units
Output Span, note 4	89.1	90.0	90.9	mV
Offset Voltage @ zero differential pressure	-	-	±0.3	mV
Offset Temperature Shift (0°C-70°C), note 2	-	-	±250	uV
Linearity, hysteresis error, note 3	-	0.15	0.30	%FSS
Span Temperature Shift (0°C-70°C), note 2	-	-	±1.0	%FSS

Performance Characteristics for 15 PSI-A-PRIME-MV

Parameter, note 1	Minimum	Nominal	Maximum	Units
Output Span, note 4	89.1	90.0	90.9	mV
Offset Voltage @ zero absolute pressure	-	-	±0.5	mV
Offset Temperature Shift (0°C-70°C), note 2	-	-	±250	uV
Linearity, hysteresis error, note 3	-	0.15	0.30	%FSS
Span Temperature Shift (0°C-70°C), note 2	-	-	±1.0	%FSS

Performance Characteristics for 30 PSI-D-PRIME-MV

Parameter, note 1	Minimum	Nominal	Maximum	Units
Output Span, note 4	89.1	90.0	90.9	mV
Offset Voltage @ zero differential pressure	-	-	±0.3	mV
Offset Temperature Shift (0°C-70°C), note 2	-	-	±250	uV
Linearity, hysteresis error, note 3	-	0.15	0.30	%FSS
Span Temperature Shift (0°C-70°C), note 2	-	-	±1.0	%FSS

Performance Characteristics for 30 PSI-A-PRIME-MV

Parameter, note 1	Minimum	Nominal	Maximum	Units
Output Span, note 4	89.1	90.0	90.9	mV
Offset Voltage @ zero absolute pressure	-	-	±0.5	mV
Offset Temperature Shift (0°C-70°C), note 2	-	-	±250	uV
Linearity, hysteresis error, note 3	-	0.15	0.30	%FSS
Span Temperature Shift (0°C-70°C), note 2	-	-	±1.0	%FSS

Performance Characteristics for 100 PSI-D-PRIME-MV

Parameter, note 1	Minimum	Nominal	Maximum	Units
Output Span, note 4	99.0	100	101	mV
Offset Voltage @ zero differential pressure	-	-	±0.3	mV
Offset Temperature Shift (0°C-70°C), note 2	-	-	±250	uV
Linearity, hysteresis error, note 3	-	0.15	0.30	%FSS
Span Temperature Shift (0°C-70°C), note 2	-	-	±1.0	%FSS

Performance Characteristics for 100 PSI-A-PRIME-MV

Parameter, note 1	Minimum	Nominal	Maximum	Units
Output Span, note 4	99.0	100	101	mV
Offset Voltage @ zero absolute pressure	-	-	±0.5	mV
Offset Temperature Shift (0°C-70°C), note 2	-	-	±250	uV
Linearity, hysteresis error, note 3	-	0.15	0.30	%FSS
Span Temperature Shift (0°C-70°C), note 2	-	-	±1.0	%FSS

Performance Characteristics for 150 PSI-D-PRIME-MV

Parameter, note 1	Minimum	Nominal	Maximum	Units
Output Span, note 4	89.1	90.0	90.1	mV
Offset Voltage @ zero differential pressure	-	-	±0.3	mV
Offset Temperature Shift (0°C-70°C), note 2	-	-	±250	uV
Linearity, hysteresis error, note 3	-	0.15	0.30	%FSS
Span Temperature Shift (0°C-70°C), note 2	-	-	±1.0	%FSS

millivolt output prime grade pressure sensors

Specification Notes

NOTE 1: ALL PARAMETERS ARE MEASURED AT 12.0 VOLT EXCITATION, FOR THE NOMINAL FULL SCALE PRESSURE AND ROOM TEMPERATURE UNLESS OTHERWISE SPECIFIED. PRESSURE MEASUREMENTS ARE WITH POSITIVE PRESSURE APPLIED TO PORT B.

NOTE 2: SHIFT IS RELATIVE TO 25°C.

NOTE 3: MEASURED AT ONE-HALF FULL SCALE RATED PRESSURE USING BEST STRAIGHT LINE CURVE FIT.

NOTE 4: THE SPAN IS THE ALGEBRAIC DIFFERENCE BETWEEN FULL SCALE OUTPUT VOLTAGE AND THE OFFSET VOLTAGE.

Pressure Response: for any pressure applied the response time to get to 90% of pressure applied is typically less than 100 useconds.

Equivalent Circuit

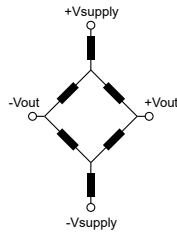

Input Resistance	5.0 k ohm
Output Resistance	3.0 k ohm

All Sensors reserves the right to make changes to any products herein. All Sensors does not assume any liability arising out of the application or use of any product or circuit described herein, neither does it convey any license under its patent rights nor the rights of others.

MINIATURE LOW PRESSURE SENSORS

Low Pressure (1" H₂O to 30" H₂O) Sensors



Features

- 0 to 1" H₂O to 0 to 30" H₂O Pressure Ranges
- Matched pressure port volumes
- Temperature Compensated
- Calibrated Zero and Span

Applications

- Medical Instrumentation
- Environmental Controls
- HVAC

General Description

The Millivolt Output pressure sensors is based upon a proprietary technology to reduce all output offset or common mode errors. This model provides a calibrated millivolt output with superior output offset characteristics. Output offset errors due to change in temperature, stability to warm-up, stability to long time period, and position sensitivity are all significantly reduced when compared to conventional compensation methods. In addition the sensor utilizes a silicon, micromachined, stress concentration enhanced structure to provide a very linear output to measured pressure.

These calibrated and temperature compensated sensors give an accurate and stable output over a wide temperature range. This series is intended for use with non-corrosive, non-ionic working fluids such as air, dry gases and the like.

The output of the device is ratiometric to the supply voltage and operation from any D.C. supply voltage up to +16 V is acceptable.

Equivalent Circuit

Input Resistance	4.5 kohm
Output Resistance	1.5 kohm

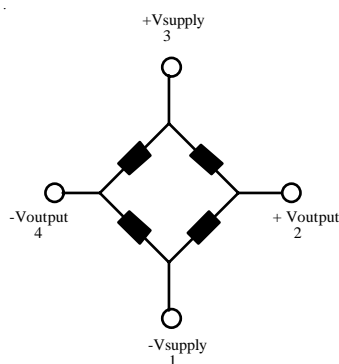

Pressure Sensor Characteristics Maximum Ratings

Supply Voltage, V_s	16 Vdc
Common-mode pressure	10 psig
Lead Temperature (soldering 2-4 sec.)	250°C

Standard Pressure Ranges

Single in Line Packages-SIP

One Port		Two Ports Same Side	Two Ports Opposite Side
Part Number	Operating Pressure	Part Number	Part Number
	0 - 1 "H ₂ O		1 INCH-D2-MV-MINI
2 INCH-G-MV-MINI	0 - 2 "H ₂ O	2 INCH-D1-MV-MINI	2 INCH-D2-MV-MINI
5 INCH-G-MV-MINI	0 - 5 "H ₂ O	5 INCH-D1-MV-MINI	5 INCH-D2-MV-MINI
10 INCH-G-MV-MINI	0 - 10 "H ₂ O	10 INCH-D1-MV-MINI	10 INCH-D2-MV-MINI
20 INCH-G-MV-MINI	0 - 20 "H ₂ O	20 INCH-D1-MV-MINI	20 INCH-D2-MV-MINI
30 INCH-G-MV-MINI	0 - 30 "H ₂ O	30 INCH-D1-MV-MINI	30 INCH-D2-MV-MINI

Dual in Line Packages

One Port		Two Ports Same Side	Two Ports Opposite Side
Part Number	Operating Pressure	Part Number	Part Number
2 INCH-GDIP-MV-MINI	0 - 2 "H ₂ O	2 INCH-D1DIP-MV-MINI	2 INCH-D2DIP-MV-MINI
5 INCH-GDIP-MV-MINI	0 - 5 "H ₂ O	5 INCH-D1DIP-MV-MINI	5 INCH-D2DIP-MV-MINI
10 INCH-GDIP-MV-MINI	0 - 10 "H ₂ O	10 INCH-D1DIP-MV-MINI	10 INCH-D2DIP-MV-MINI
20 INCH-GDIP-MV-MINI	0 - 20 "H ₂ O	20 INCH-D1DIP-MV-MINI	20 INCH-D2DIP-MV-MINI
30 INCH-GDIP-MV-MINI	0 - 30 "H ₂ O	30 INCH-D1DIP-MV-MINI	30 INCH-D2DIP-MV-MINI

Performance Characteristics for 1 INCH-D2-MV-MINI

Parameter, note 1	Minimum	Nominal	Maximum	Units
Operating Range, differential pressure		1.0		"H ₂ O
Output Span, @ 1 "H ₂ O, note 5	8.0	10	12.0	mV
Offset Voltage @ zero differential pressure			±500	mV
Offset Temperature Shift (0°C-50°C), note 2			±250	µV
Offset Warm-up Shift, note 3			±100	µV
Offset Position Sensitivity (1g)			±50	µV
Offset Long Term Drift (one year)			±200	µV
Linearity, hysteresis error, note 4		0.05	0.25	%fs
Span Shift (0°C-50°C), @ 1 "H ₂ O, note 2			±300	µV

Performance Characteristics for 2 INCH-Dx-MV-MINI

Parameter, note 1	Minimum	Nominal	Maximum	Units
Operating Range, differential pressure		20		"H ₂ O
Output Span, @ 2 "H ₂ O, note 5	9.0	10.0	11.0	mV
Operating Range, differential pressure		40		mV
Output Span, @ 4 "H ₂ O, note 5	18.0	20.0	22.0	mV
Offset Voltage @ zero differential pressure			±500	µV
Offset Temperature Shift (0°C-50°C), note 2			±250	µV
Offset Warm-up Shift, note 3			±100	µV
Offset Position Sensitivity (1g)			±50	µV
Offset Long Term Drift (one year)			±200	µV
Linearity, hysteresis error, note 4		0.05	0.25	%fs
Span Shift (0°C-50°C), @ 2 "H ₂ O, note 2			±200	µV

Performance Characteristics for 5 INCH-Dx-MV-MINI

Parameter, note 1	Minimum	Nominal	Maximum	Units
Operating Range, differential pressure		5.0		"H ₂ O
Output Span, note 5	19.0	20.0	21.0	mV
Offset Voltage @ zero differential pressure			±500	µV
Offset Temperature Shift (0°C-50°C), note 2			±150	µV
Offset Warm-up Shift, note 3			±50	µV
Offset Position Sensitivity (1g)			±10	µV
Offset Long Term Drift (one year)			±100	µV
Linearity, hysteresis error, note 4		0.05	0.25	%fs
Span Shift (0°C-50°C), note 2			±200	µV

Performance Characteristics for 10 INCH-Dx-MV-MINI

Parameter, note 1	Minimum	Nominal	Maximum	Units
Operating Range, differential pressure		10.0		"H ₂ O
Output Span, note 5	19.0	20.0	21.0	mV
Offset Voltage @ zero differential pressure			±500	µV
Offset Temperature Shift (0°C-70°C), note 2			±150	µV
Offset Warm-up Shift, note 3			±50	µV
Offset Position Sensitivity (1g)			±5	µV
Offset Long Term Drift (one year)			±100	µV
Linearity, hysteresis error, note 4		0.05	0.25	%fs
Span Shift (0°C-70°C), note 2			±200	µV

Performance Characteristics for 20 INCH-Dx-MV-MINI

Parameter, note 1	Minimum	Nominal	Maximum	Units
Operating Range, differential pressure		5.0		"H ₂ O
Output Span, note 5	19.0	20.0	21.0	mV
Offset Voltage @ zero differential pressure			±500	µV
Offset Temperature Shift (0°C-70°C), note 2			±150	µV
Offset Warm-up Shift, note 3			±50	µV
Offset Position Sensitivity (1g)			±5	µV
Offset Long Term Drift (one year)			±100	µV
Linearity, hysteresis error, note 4		0.05	0.25	%fs
Span Shift (0°C-70°C), note 2			±200	µV

Performance Characteristics for 30 INCH-Dx-MV-MINI

Parameter, note 1	Minimum	Nominal	Maximum	Units
Operating Range, differential pressure		30.0		"H ₂ O
Output Span, note 5	19.0	20.0	21.0	mV
Offset Voltage @ zero differential pressure			±500	µV
Offset Temperature Shift (0°C-70°C), note 2			±150	µV
Offset Warm-up Shift, note 3			±50	µV
Offset Position Sensitivity (1g)			±5	µV
Offset Long Term Drift (one year)			±100	µV
Linearity, hysteresis error, note 4		0.05	0.25	%fs
Span Shift (0°C-70°C), note 2			±200	µV

Specification Notes

NOTE 1: ALL PARAMETERS ARE MEASURED AT 12.0 VOLT EXCITATION, FOR THE NOMINAL FULL SCALE PRESSURE AND ROOM TEMPERATURE UNLESS OTHERWISE SPECIFIED. PRESSURE MEASUREMENTS ARE WITH POSITIVE PRESSURE APPLIED TO THE B-PORT CONFIGURATION.

NOTE 2: SHIFT IS RELATIVE TO 25°C.

NOTE 3: SHIFT IS WITHIN THE FIRST HOUR OF EXCITATION APPLIED TO THE DEVICE.

NOTE 4: MEASURED AT ONE-HALF FULL SCALE RATED PRESSURE USING BEST STRAIGHT LINE CURVE FIT.

NOTE 5: THE VOLTAGE ADDED TO THE OFFSET VOLTAGE AT FULL SCALE PRESSURE.

Physical Dimensions

Dual in Line (SDXL)**

pin 1: +Vout
pin 2: gnd
pin 3: -Vout
pin 5: Vsupply

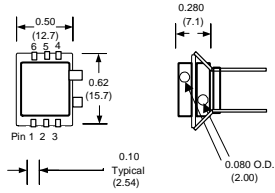

Two Pressure Port Same Side

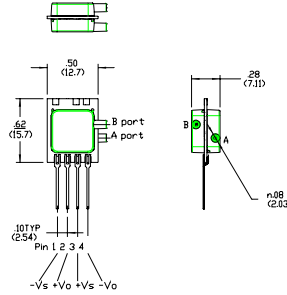

Dual in Line (DIP)

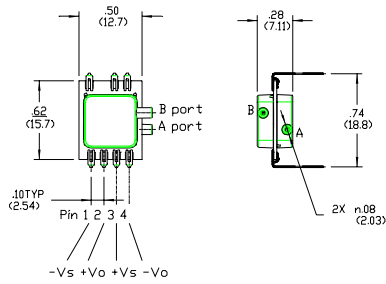

Two Pressure Port Two Sides

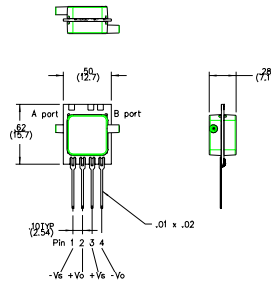

**SDXL ORDERING INFORMATION

One Port	Operating Pressure	Two Ports Same Side	Two Ports Opposite Side
Part Number		Part Number	Part Number
2 INCH-GDIP-MV-SDXL	0-2 "H ₂ O	2 INCH-D1DIP-MV-SDXL	2 INCH-D2DIP-MV-SDXL
5 INCH-GDIP-MV-SDXL	0-5 "H ₂ O	5 INCH-D1DIP-MV-SDXL	5 INCH-D2DIP-MV-SDXL
10 INCH-GDIP-MV-SDXL	0-10 "H ₂ O	10 INCH-D1DIP-MV-SDXL	10 INCH-D2DIP-MV-SDXL
20 INCH-GDIP-MV-SDXL	0-20 "H ₂ O	20 INCH-D1DIP-MV-SDXL	20 INCH-D2DIP-MV-SDXL
30 INCH-GDIP-MV-SDXL	0-30 "H ₂ O	30 INCH-D1DIP-MV-SDXL	30 INCH-D2DIP-MV-SDXL



Millivolt Output Pressure Sensors



Package A

Features

- Temperature Compensated
- Calibrated Zero and Span



Package M

Applications

- Non Invasive Blood Pressure

General Description

This data sheet describes two package configuration of pressure sensors for use in non invasive blood pressure measurement. The output voltage is ratiometric to the supply voltage and is offered in either millivolt or amplified output configuration.

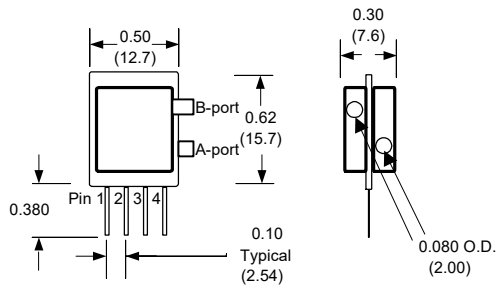

- pin 1: +V supply**
- pin 2: Ground**
- pin 3: +Voutput**
- pin 4: -N/C**



- pin 1: N/C**
- pin 2: +V supply**
- pin 3: +Voutput**
- pin 4: -Vsupply**
- pin 5: -Voutput**
- pin 6: N/C**



Pressure Sensor Characteristics Maximum Ratings

Supply Voltage VS	see below
Proof Pressure	1500mmHg
Lead Temperature (soldering 2-4 sec.)	250°C

Environmental Specifications

Temperature Ranges	
Compensated	10 to 50° C
Operating	-25 to 85° C
Storage	-40 to 125° C
Humidity Limits	0 to 95% RH (non condensing)

Standard Package Types

Part Number-Side Port	Package Type	Nominal Span	Supply Voltage
BP01-D-MV	A	15mV	5 volts
BP01-G-4V-MINI	M	4.2 volts	5 volts

Performance Characteristics for BP01-D-MV

Parameter, note 1	Minimum	Nominal	Maximum	Units
Operating Range, gage pressure		300		mmHg
Output Span, note 4	14.85	15.0	15.15	mV
Offset Voltage @ zero pressure		0	0±5	mmHg
Offset Temperature Shift (10°C-50°C), note 2			±0.2	mmHg/°C
Linearity, hysteresis error 0 - 200 mmHg, note 3			±0.1	%fs
Linearity, hysteresis error 0 - 300 mmHg, note 3			±0.2	%fs
Span Shift (10°C-50°C), note 2			±0.5	%fs

Performance Characteristics for BP01-G-4V-MINI

Parameter, note 1	Minimum	Nominal	Maximum	Units
Operating Range, gage pressure		300		mmHg
Output Span, note 4	4.1	4.2	4.3	V
Offset Voltage @ zero pressure	0.18	0.25	0.32	V
Offset Temperature Shift (10°C-50°C), note 2			±0.2	mmHg/°C
Linearity, hysteresis error 0 - 200 mmHg, note 3			±0.1	%fs
Linearity, hysteresis error 0 - 300 mmHg, note 3			±0.2	%fs
Span Shift (10°C-50°C), note 2			±0.5	%fs

Specification Notes

NOTE 1: ALL PARAMETERS ARE MEASURED AT ROOM TEMPERATURE UNLESS OTHERWISE SPECIFIED. PRESSURE MEASUREMENTS ARE WITH POSITIVE PRESSURE APPLIED TO PORT B.

NOTE 2: SHIFT IS RELATIVE TO 25°C READINGS TAKEN AT 10°C AND 50°C.

NOTE 3: MEASURED AT ONE-HALF FULL SCALE RATED PRESSURE USING BEST STRAIGHT LINE CURVE FIT.

NOTE 4: THE VOLTAGE ADDED TO THE OFFSET VOLTAGE AT FULL SCALE PRESSURE.

All Sensors reserves the right to make changes to any products herein. All Sensors does not assume any liability arising out of the application or use of any product or circuit described herein, neither does it convey any license under its patent rights nor the rights of others.

MINIATURE PRESSURE SENSORS

C-Grade
Pressure Sensors



Features

- 0 to 4" H₂O to 0 to 100 PSI Pressure Ranges
- 1 % linearity version
- Temperature Compensated
- Calibrated Zero and Span

Applications

- Medical Instrumentation
- Environmental Controls
- HVAC

General Description

The Miniature series pressure sensors are based upon a proprietary technology to reduce the size of the sensor and yet maintain a high level of performance. This model provides a calibrated millivolt output with superior output offset characteristics. Output offset errors due to change in temperature, stability to warm-up, stability to long time period, and position sensitivity are all significantly reduced when compared to conventional compensation methods. In addition the sensor utilizes a silicon, micromachined, stress concentration enhanced structure to provide a very linear output to measured pressure.

These calibrated and temperature compensated sensors give an accurate and stable output over a wide temperature range. This series is intended for use with non-corrosive, non-ionic working fluids such as air, dry gases and the like. The C-GRADE is a lowest cost version of the millivolt output pressure sensors.

The output of the device is ratiometric to the supply voltage and operation from any D.C. supply voltage.

Physical Dimensions

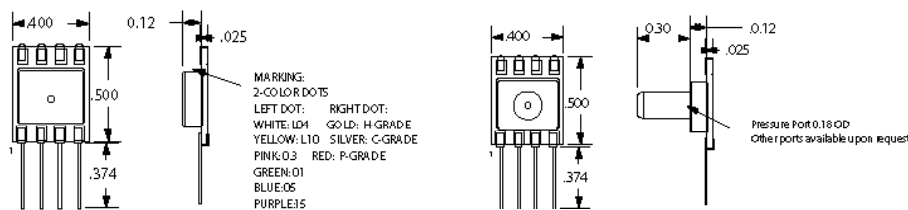

all dimensions in inches

No Pressure Port

Single Pressure Port

Dual Pressure Port

Marking:
right dot: Silver C-Grade
left dot:
L04: white
L10: yellow
0.3: pink
1.0: green
05: blue
15: purple
30: orange
100: brown

Equivalent Circuit

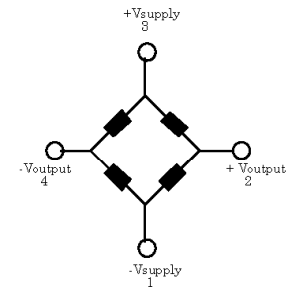

Input Resistance 5.0 k ohm

Output Resistance 3.0 k ohm

Approvals

MKT	DATE	MFG	DATE	ENG	DATE	QA	DATE
<input type="checkbox"/> As Is <input type="checkbox"/> With Change		<input type="checkbox"/> As Is <input type="checkbox"/> With Change		<input type="checkbox"/> As Is <input type="checkbox"/> With Change		<input type="checkbox"/> As Is <input type="checkbox"/> With Change	



Pressure Sensor Characteristics Maximum Ratings

Supply Voltage VS	16 Vdc
Common-mode pressure	50 psig
Lead Temperature (soldering 2-4 sec.)	250°C

Environmental Specifications

Temperature Ranges	
Compensated	0 to 70° C
Operating	-25 to 85° C
Storage	-40 to 125° C
Humidity Limits	0 to 95% RH (non condensing)

Standard Pressure Ranges

No Pressure Port		Single Pressure Port		Dual Pressure Port	
Part Number	Operating Pressure	Part Number	Part Number	Proof Pressure	
4 INCH-G-CGRADE-MINI	0 - 4 "H2O	4 INCH-GF-CGRADE-MINI	4 INCH-D-CGRADE-MINI	3 PSI	
0.3 PSI-G-CGRADE-MINI	0 - 0.3 PSI	0.3 PSI-GF-CGRADE-MINI	0.3 PSI-D-CGRADE-MINI	3 PSI	
10 INCH-G-CGRADE-MINI	0 - 10 "H2O	10 INCH-GF-CGRADE-MINI	10 INCH-D-CGRADE-MINI	5 PSI	
1 PSI-G-CGRADE-MINI	0 - 1 PSI	1 PSI-GF-CGRADE-MINI	1 PSI-D-CGRADE-MINI	10 PSI	
5 PSI-G-CGRADE-MINI	0 - 5 PSI	5 PSI-GF-CGRADE-MINI	5 PSI-D-CGRADE-MINI	20 PSI	
15 PSI-A-CGRADE-MINI	0 - 15 PSIA	15 PSI-AF-CGRADE-MINI		60 PSI	
15 PSI-G-CGRADE-MINI	0-15 PSI	15 PSI-GF-CGRADE-MINI	15 PSI-D-CGRADE-MINI	60 PSI	
30 PSI-A-CGRADE-MINI	0-30 PSIA	30 PSI-AF-CGRADE-MINI		60 PSI	
30 PSI-G-CGRADE-MINI	0-30 PSI	30 PSI-GF-CGRADE-MINI	30 PSI-D-CGRADE-MINI	60 PSI	
100 PSI-G-CGRADE-MINI	0-100 PSI	100 PSI-GF-CGRADE-MINI		150 PSI	

Performance Characteristics for 4 INCH-G-CGRADE-MINI

Parameter, note 1	Minimum	Nominal	Maximum	Units
Operating Range, differential pressure	--	4.0	--	"H2O
Output Span, note 5	23	25	27	mV
Offset Voltage @ zero differential pressure	--	--	±1.5	mV
Offset Temperature Shift (0°C-50°C), note 2	--	--	±1.5	mV
Linearity, hysteresis error, note 4	--	0.5	1.0	%fs
Span Shift (0°C-50°C), note 2	--	--	±2	%fs

Performance Characteristics for 10 INCH-G-CGRADE-MINI

Parameter, note 1	Minimum	Nominal	Maximum	Units
Operating Range, differential pressure	--	10.0	--	"H2O
Output Span, note 5	18	20	22	mV
Offset Voltage @ zero differential pressure	--	--	±1.5	mV
Offset Temperature Shift (0°C-70°C), note 2	--	--	±1.5	mV
Linearity, hysteresis error, note 4	--	0.5	1.0	%fs
Span Shift (0°C-70°C), note 2	--	--	±2	%fs

Performance Characteristics for 0.3 PSI-G-CGRADE-MINI

Parameter, note 1	Minimum	Nominal	Maximum	Units
Operating Range, differential pressure	--	0.3	--	PSI
Output Span, note 5	18	20.0	22	mV
Offset Voltage @ zero differential pressure	--	--	±1	mV
Offset Temperature Shift (0°C-70°C), note 2	--	--	±1	mV
Linearity, hysteresis error, note 4	--	0.5	1	%fs
Span Shift (0°C-70°C), note 2	--	--	±2	%fs

Performance Characteristics for 1 PSI-G-CGRADE-MINI

Parameter, note 1	Minimum	Nominal	Maximum	Units
Operating Range, differential pressure	--	1.0	--	PSI
Output Span, note 5	16	18	20	mV
Offset Voltage @ zero differential pressure	--	--	±1	mV
Offset Temperature Shift (0°C-70°C), note 2	--	--	±1	mV
Linearity, hysteresis error, note 4	--	0.5	1.0	%fs
Span Shift (0°C-70°C), note 2	--	--	±2	%fs

Performance Characteristics for 5 PSI-G-CGRADE-MINI

Parameter, note 1	Minimum	Nominal	Maximum	Units
Operating Range, differential pressure	--	5.0	--	PSI
Output Span, note 5	57	60	63	mV
Offset Voltage @ zero differential pressure	--	--	±1	mV
Offset Temperature Shift (0°C-70°C), note 2	--	--	±1	mV
Linearity, hysteresis error, note 4	--	0.5	1.0	%fs
Span Shift (0°C-70°C), note 2	--	--	±2	%fs

Performance Characteristics for 15 PSI-G-CGRADE-MINI

Parameter, note 1	Minimum	Nominal	Maximum	Units
Operating Range, gage pressure	--	15.0	--	PSI
Output Span, note 5	85	90.0	95	mV
Offset Voltage @ zero gage pressure	--	--	±1	mV
Offset Temperature Shift (0°C-70°C), note 2	--	--	±1	mV
Linearity, hysteresis error, note 4	--	0.5	1.0	%fs
Span Shift (0°C-70°C), note 2	--	--	±2	%fs



Performance Characteristics for 15 PSI-A-CGRADE-MINI

Parameter, note 1	Minimum	Nominal	Maximum	Units
Operating Range, absolute pressure	--	15.0	--	PSIA
Output Span, note 5	85	90.0	95	mV
Offset Voltage @ zero absolute pressure	--	--	±1	mV
Offset Temperature Shift (0°C-70°C), note 2	--	--	±1	mV
Linearity, hysteresis error, note 4	--	0.5	1.0	%fs
Span Shift (0°C-70°C), note 2	--	--	±2	%fs

Performance Characteristics for 30 PSI-G-CGRADE-MINI

Parameter, note 1	Minimum	Nominal	Maximum	Units
Operating Range, gage pressure	--	30.0	--	PSI
Output Span, note 5	85	90.0	95	mV
Offset Voltage @ zero pressure	--	--	±1	mV
Offset Temperature Shift (0°C-70°C), note 2	--	--	±1	mV
Linearity, hysteresis error, note 4	--	0.5	1.0	%fs
Span Shift (0°C-70°C), note 2	--	--	±2	%fs

Performance Characteristics for 30 PSI-A-CGRADE-MINI

Parameter, note 1	Minimum	Nominal	Maximum	Units
Operating Range, absolute pressure	--	30.0	--	PSIA
Output Span, note 5	85	90.0	95	mV
Offset Voltage @ zero absolute pressure	--	--	±1	mV
Offset Temperature Shift (0°C-70°C), note 2	--	--	±1	mV
Linearity, hysteresis error, note 4	--	0.5	1.0	%fs
Span Shift (0°C-70°C), note 2	--	--	±2	%fs

Performance Characteristics for 100 PSI-G-CGRADE-MINI

Parameter, note 1	Minimum	Nominal	Maximum	Units
Operating Range, gage pressure	--	100.0	--	PSI
Output Span, note 5	95	100.0	105	mV
Offset Voltage @ zero pressure	--	--	±1	mV
Offset Temperature Shift (0°C-70°C), note 2	--	--	±1	mV
Linearity, hysteresis error, note 4	--	0.5	1.0	%fs
Span Shift (0°C-70°C), note 2	--	--	±2	%fs

Specification Notes

NOTE 1: ALL PARAMETERS ARE MEASURED AT 12.0 VOLT EXCITATION, FOR THE NOMINAL FULL SCALE PRESSURE AND ROOM TEMPERATURE UNLESS OTHERWISE SPECIFIED. PRESSURE MEASUREMENTS ARE WITH POSITIVE PRESSURE APPLIED TO PORT B.

NOTE 2: SHIFT IS RELATIVE TO 25°C.

NOTE 3: SHIFT IS WITHIN THE FIRST HOUR OF EXCITATION APPLIED TO THE DEVICE.

NOTE 4: MEASURED AT ONE-HALF FULL SCALE RATED PRESSURE USING BEST STRAIGHT LINE CURVE FIT.

NOTE 5: THE VOLTAGE ADDED TO THE OFFSET VOLTAGE AT FULL SCALE PRESSURE.

Pressure Response: for any pressure applied the response time to get to 90% of pressure applied is typically less than 100 useconds.

MINIATURE PRESSURE SENSORS

H-Grade
Pressure Sensors



Features

- 0 to 4" H₂O to 0 to 100 PSI Pressure Ranges
- 0.5 % linearity...high accuracy version
- Temperature Compensated
- Calibrated Zero and Span

Applications

- Environmental Controls
- HVAC

General Description

The Miniature series pressure sensors are based upon a proprietary technology to reduce the size of the sensor and yet maintain a high level of performance. This model provides a calibrated millivolt output with superior output offset characteristics. Output offset errors due to change in temperature, stability to warm-up, stability to long time period, and position sensitivity are all significantly reduced when compared to conventional compensation methods. In addition the sensor utilizes a silicon, micromachined, stress concentration enhanced structure to provide a very linear output to measured pressure.

These calibrated and temperature compensated sensors give an accurate and stable output over a wide temperature range. This series is intended for use with non-corrosive, non-ionic working fluids such as air, dry gases and the like. The H-GRADE is a high accuracy version of the millivolt output pressure sensors.

The output of the device is ratiometric to the supply voltage and operation from any D.C. supply voltage.

Physical Dimensions

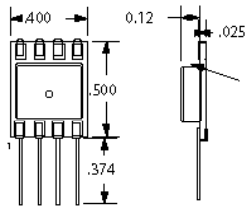

No Pressure Port

MARKING:
2-COLOR DOTS
LEFT DOT: RIGHT DOT:
WHITE: L04 GOLD: H-GRADE
YELLOW: L10 SILVER: C-GRADE
PINK: 0.3 RED: P-GRADE
GREEN: 01
BLUE: 05
PURPLE: 15

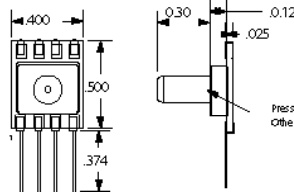

Single Pressure Port

Pressure Port 0.18 OD
Other ports available upon request

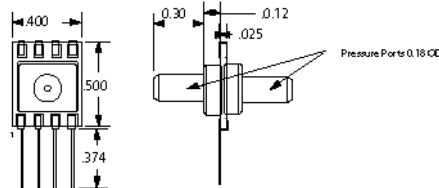

Dual Pressure Port

Pressure Ports 0.18 OD

Equivalent Circuit

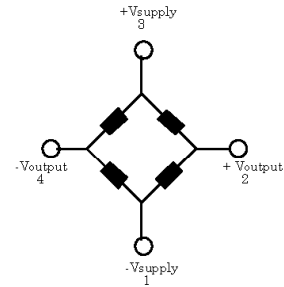

Input Resistance 5.0 k ohm

Output Resistance 3.0 k ohm

- Marking:
right dot: gold: H-Grade
left dot:
L04: white
L10: yellow
0.3: pink
L0: green
05: blue
15: purple
30: orange
100: brown

Approvals

MKT	DATE	MFG	DATE	ENG	DATE	QA	DATE
<input type="checkbox"/> As Is <input type="checkbox"/> With Change		<input type="checkbox"/> As Is <input type="checkbox"/> With Change		<input type="checkbox"/> As Is <input type="checkbox"/> With Change		<input type="checkbox"/> As Is <input type="checkbox"/> With Change	



Pressure Sensor Characteristics Maximum Ratings

Supply Voltage VS	16 Vdc
Common-mode pressure	50 psig
Lead Temperature (soldering 2-4 sec.)	250°C

Environmental Specifications

Temperature Ranges	
Compensated	0 to (50)70° C
Operating	-25 to 85° C
Storage	-40 to 125° C
Humidity Limits	0 to 95% RH (non condensing)

Standard Pressure Ranges

No Pressure Port		Single Pressure Port		Dual Pressure Port	Proof Pressure
Part Number	Operating Pressure	Part Number	Part Number	Part Number	
4 INCH-G-HGRADE-MINI	0 - 4 "H2O	4 INCH-GF-HGRADE-MINI	4 INCH-D-HGRADE-MINI	4 INCH-D-HGRADE-MINI	3 PSI
0.3 PSI-G-HGRADE-MINI	0 - 0.3 PSI	0.3 PSI-GF-HGRADE-MINI	0.3 PSI-D-HGRADE-MINI	0.3 PSI-D-HGRADE-MINI	3 PSI
10 INCH-G-HGRADE-MINI	0 - 10 "H2O	10 INCH-GF-HGRADE-MINI	10 INCH-D-HGRADE-MINI	10 INCH-D-HGRADE-MINI	5 PSI
1 PSI-G-HGRADE-MINI	0 - 1 PSI	1 PSI-GF-HGRADE-MINI	1 PSI-D-HGRADE-MINI	1 PSI-D-HGRADE-MINI	10 PSI
5 PSI-G-HGRADE-MINI	0 - 5 PSI	5 PSI-GF-HGRADE-MINI	5 PSI-D-HGRADE-MINI	5 PSI-D-HGRADE-MINI	20 PSI
15 PSI-A-HGRADE-MINI	0 - 15 PSIA	15 PSI-AF-HGRADE-MINI			60 PSI
15 PSI-G-HGRADE-MINI	0-15 PSI	15 PSI-GF-HGRADE-MINI	15 PSI-D-HGRADE-MINI	15 PSI-D-HGRADE-MINI	60 PSI
30 PSI-A-HGRADE-MINI	0 -30 PSIA	30 PSI-AF-HGRADE-MINI			60 PSI
30 PSI-G-HGRADE-MINI	0-30 PSI	30 PSI-GF-HGRADE-MINI	30 PSI-D-HGRADE-MINI	30 PSI-D-HGRADE-MINI	60 PSI
100 PSI-G-HGRADE-MINI	0-100 PSI	100 PSI-GF-HGRADE-MINI			150 PSI

Performance Characteristics for 4 INCH-G-HGRADE-MINI

Parameter, note 1	Minimum	Nominal	Maximum	Units
Operating Range, differential pressure	--	4.0	--	"H2O
Output Span, note 5	24	25	26	mV
Offset Voltage @ zero differential pressure	--	--	±0.5	mV
Offset Temperature Shift (0°C-50°C), note 2	--	--	±0.5	mV
Linearity, hysteresis error, note 4	--	0.25	0.5	%fs
Span Shift (0°C-50°C), note 2	--	--	±1	%fs

Performance Characteristics for 10 INCH-G-HGRADE-MINI

Parameter, note 1	Minimum	Nominal	Maximum	Units
Operating Range, differential pressure	--	10.0	--	"H2O
Output Span, note 5	19	20	21	mV
Offset Voltage @ zero differential pressure	--	--	±0.5	mV
Offset Temperature Shift (0°C-70°C), note 2	--	--	±0.5	mV
Linearity, hysteresis error, note 4	--	0.25	0.5	%fs
Span Shift (0°C-70°C), note 2	--	--	±1	%fs

Performance Characteristics for 0.3 PSI-G-HGRADE-MINI

Parameter, note 1	Minimum	Nominal	Maximum	Units
Operating Range, differential pressure	--	0.3	--	PSI
Output Span, note 5	19	20	21	mV
Offset Voltage @ zero differential pressure	--	--	±0.5	mV
Offset Temperature Shift (0°C-70°C), note 2	--	--	±0.5	mV
Linearity, hysteresis error, note 4	--	0.25	0.5	%fs
Span Shift (0°C-70°C), note 2	--	--	±1	%fs

Performance Characteristics for 1 PSI-G-HGRADE-MINI

Parameter, note 1	Minimum	Nominal	Maximum	Units
Operating Range, differential pressure	--	1.0	--	PSI
Output Span, note 5	17.82	18.00	18.18	mV
Offset Voltage @ zero differential pressure	--	--	±0.5	mV
Offset Temperature Shift (0°C-70°C), note 2	--	--	±0.5	mV
Linearity, hysteresis error, note 4	--	0.25	0.5	%fs
Span Shift (0°C-70°C), note 2	--	--	±1	%fs

Performance Characteristics for 5 PSI-G-HGRADE-MINI

Parameter, note 1	Minimum	Nominal	Maximum	Units
Operating Range, differential pressure	--	5.0	--	PSI
Output Span, note 5	59.4	60.0	60.6	mV
Offset Voltage @ zero differential pressure	--	--	±0.5	mV
Offset Temperature Shift (0°C-70°C), note 2	--	--	±0.5	mV
Linearity, hysteresis error, note 4	--	0.25	0.5	%fs
Span Shift (0°C-70°C), note 2	--	--	±1	%fs

Performance Characteristics for 15 PSI-G-HGRADE-MINI

Parameter, note 1	Minimum	Nominal	Maximum	Units
Operating Range, gage pressure	--	15.0	--	PSI
Output Span, note 5	89.1	90.0	90.9	mV
Offset Voltage @ zero gage pressure	--	--	±0.5	mV
Offset Temperature Shift (0°C-70°C), note 2	--	--	±0.5	mV
Linearity, hysteresis error, note 4	--	0.25	0.5	%fs
Span Shift (0°C-70°C), note 2	--	--	±1	%fs



Performance Characteristics for 15 PSI-A-HGRADE-MINI

Parameter, note 1	Minimum	Nominal	Maximum	Units
Operating Range, absolute pressure	--	15.0	--	PSIA
Output Span, note 5	89.1	90.0	90.9	mV
Offset Voltage @ zero differential pressure	--	--	±0.5	mV
Offset Temperature Shift (0°C-70°C), note 2	--	--	±0.5	mV
Linearity, hysteresis error, note 4	--	0.25	0.5	%fs
Span Shift (0°C-70°C), note 2	--	--	±1	%fs

Performance Characteristics for 30 PSI-G-HGRADE-MINI

Parameter, note 1	Minimum	Nominal	Maximum	Units
Operating Range, gage pressure	--	30.0	--	PSI
Output Span, note 5	89.1	90.0	90.9	mV
Offset Voltage @ zero gage pressure	--	--	±0.5	mV
Offset Temperature Shift (0°C-70°C), note 2	--	--	±0.5	mV
Linearity, hysteresis error, note 4	--	0.25	0.5	%fs
Span Shift (0°C-70°C), note 2	--	--	±1	%fs

Performance Characteristics for 30 PSI-A-HGRADE-MINI

Parameter, note 1	Minimum	Nominal	Maximum	Units
Operating Range, absolute pressure	--	30.0	--	PSIA
Output Span, note 5	89.1	90.0	90.9	mV
Offset Voltage @ zero differential pressure	--	--	±0.5	mV
Offset Temperature Shift (0°C-70°C), note 2	--	--	±0.5	mV
Linearity, hysteresis error, note 4	--	0.25	0.5	%fs
Span Shift (0°C-70°C), note 2	--	--	±1	%fs

Performance Characteristics for 100 PSI-G-HGRADE-MINI

Parameter, note 1	Minimum	Nominal	Maximum	Units
Operating Range, gage pressure	--	100.0	--	PSI
Output Span, note 5	99.0	100.0	101.0	mV
Offset Voltage @ zero gage pressure	--	--	±0.5	mV
Offset Temperature Shift (0°C-70°C), note 2	--	--	±0.5	mV
Linearity, hysteresis error, note 4	--	0.25	0.5	%fs
Span Shift (0°C-70°C), note 2	--	--	±1	%fs

Specification Notes

NOTE 1: ALL PARAMETERS ARE MEASURED AT 12.0 VOLT EXCITATION, FOR THE NOMINAL FULL SCALE PRESSURE AND ROOM TEMPERATURE UNLESS OTHERWISE SPECIFIED. PRESSURE MEASUREMENTS ARE WITH POSITIVE PRESSURE APPLIED TO PORT B.

NOTE 2: SHIFT IS RELATIVE TO 25°C.

NOTE 3: SHIFT IS WITHIN THE FIRST HOUR OF EXCITATION APPLIED TO THE DEVICE.

NOTE 4: MEASURED AT ONE-HALF FULL SCALE RATED PRESSURE USING BEST STRAIGHT LINE CURVE FIT.

NOTE 5: THE VOLTAGE ADDED TO THE OFFSET VOLTAGE AT FULL SCALE PRESSURE.

Pressure Response: for any pressure applied the response time to get to 90% of pressure applied is typically less than 100 useconds.

All Sensors reserves the right to make changes to any products herein. All Sensors does not assume any liability arising out of the application or use of any product or circuit described herein, neither does it convey any license under its patent rights nor the rights of others.

Miniature Pressure Sensors

Prime Grade Pressure Sensors

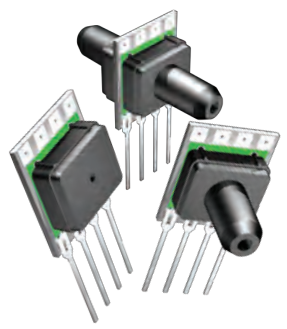

Features

- 0 to 0.3 PSI to 0 to 100 PSI Pressure Ranges
- Highest accuracy version
- Temperature Compensated
- Calibrated Zero and Span

Applications

- Medical Instrumentation
- Environmental Controls
- HVAC

General Description

The Miniature series pressure sensors are based upon a proprietary technology to reduce the size of the sensor and yet maintain a high level of performance. This model provides a calibrated millivolt output with superior output characteristics. In addition the sensor utilizes a silicon, micromachined, stress concentration enhanced structure to provide a very linear output to measured pressure.

These calibrated and temperature compensated sensors give an accurate and stable output over a wide temperature range. This series is intended for use with non-corrosive, non-ionic working fluids such as air, dry gases and the like. The PRIME GRADE is the highest accuracy version of the millivolt output pressure sensors.

The output of the device is ratiometric to the supply voltage and operation from any D.C. supply voltage.

Pressure Sensor Characteristics Maximum Ratings

Supply Voltage, V_s	16 Vdc
Common-mode pressure	50 psig
Lead Temperature (soldering 2-4 sec.)	270°C

Environmental Specifications

Temperature Ranges	
Compensated	0 to 70° C
Operating	-25 to 85° C
Storage	-40 to 125° C
Humidity Limits	0 to 95% RH (non condensing)

Approvals

MKT	DATE	MFG	DATE	ENG	DATE	QA	DATE
<input type="checkbox"/> As Is <input type="checkbox"/> With Change		<input type="checkbox"/> As Is <input type="checkbox"/> With Change		<input type="checkbox"/> As Is <input type="checkbox"/> With Change		<input type="checkbox"/> As Is <input type="checkbox"/> With Change	

All Sensors

DS-0110 Rev E

Standard Pressure Ranges

No Pressure Port: CFNS		Single Pressure Port: CPNS		Dual Pressure Port: CPPS	
Part Number	Part Number	Part Number	Operating Pressure	Proof Pressure	
0.3 PSI-G-PRIME-MINI	0.3 PSI-GF-PRIME-MINI	0.3 PSI-D-PRIME-MINI	0 to 0.3 PSI	3 PSI	
10 INCH-G-PRIME-MINI	10 INCH-GF-PRIME-MINI	10 INCH-D-PRIME-MINI	0 to 10 inH2O	5 PSI	
1 PSI-G-PRIME-MINI	1 PSI-GF-PRIME-MINI	1 PSI-D-PRIME-MINI	0 to 1 PSI	10 PSI	
5 PSI-G-PRIME-MINI	5 PSI-GF-PRIME-MINI	5 PSI-D-PRIME-MINI	0 to 5 PSI	20 PSI	
15 PSI-A-PRIME-MINI	15 PSI-AF-PRIME-MINI		0 to 15 PSIA	60 PSIA	
15 PSI-G-PRIME-MINI	15 PSI-GF-PRIME-MINI	15 PSI-D-PRIME-MINI	0 to 15 PSI	60 PSI	
30 PSI-A-PRIME-MINI	30 PSI-AF-PRIME-MINI		0 to 30 PSIA	60 PSIA	
30 PSI-G-PRIME-MINI	30 PSI-GF-PRIME-MINI	30 PSI-D-PRIME-MINI	0 to 30 PSI	60 PSI	
100 PSI-A-PRIME-MINI	100 PSI-AF-PRIME-MINI		0 to 100 PSIA	150 PSIA	
100 PSI-G-PRIME-MINI	100 PSI-GF-PRIME-MINI		0 to 100 PSI	150 PSI	

Performance Characteristics for: 0.3 PSI-G-PRIME-MINI , 0.3 PSI-GF-PRIME-MINI , 0.3 PSI-D-PRIME-MINI

Parameter, note 1	Minimum	Nominal	Maximum	Units
Output Span, note 4	19.0	20.0	21.0	mV
Offset Voltage @ zero differential pressure	--	--	±0.3	mV
Offset Temperature Shift (0°C-70°C), note 2	--	--	±250	uV
Linearity, hysteresis error, note 3	--	0.1	0.25	%FSS
Span Temperature Shift (0°C-70°C), note 2	--	--	±1.0	%FSS

Performance Characteristics for: 10 INCH-G-PRIME-MINI , 10 INCH-GF-PRIME-MINI , 10 INCH-D-PRIME-MINI

Parameter, note 1	Minimum	Nominal	Maximum	Units
Output Span, note 4	19.0	20.0	21.0	mV
Offset Voltage @ zero differential pressure	--	--	±0.3	mV
Offset Temperature Shift (0°C-70°C), note 2	--	--	±250	uV
Linearity, hysteresis error, note 3	--	0.1	0.25	%FSS
Span Temperature Shift (0°C-70°C), note 2	--	--	±1.0	%FSS

Performance Characteristics for: 1 PSI-G-PRIME-MINI , 1 PSI-GF-PRIME-MINI , 1 PSI-D-PRIME-MINI

Parameter, note 1	Minimum	Nominal	Maximum	Units
Output Span, note 4	17.82	18.0	18.18	mV
Offset Voltage @ zero differential pressure	--	--	±0.3	mV
Offset Temperature Shift (0°C-70°C), note 2	--	--	±250	uV
Linearity, hysteresis error, note 3	--	0.1	0.25	%FSS
Span Temperature Shift (0°C-70°C), note 2	--	--	±1.0	%FSS

Miniature Prime Grade Pressure Sensors

Performance Characteristics for: 5 PSI-G-PRIME-MINI , 5 PSI-GF-PRIME-MINI , 5 PSI-D-PRIME-MINI

Parameter, note 1	Minimum	Nominal	Maximum	Units
Output Span, note 4	59.4	60.0	60.6	mV
Offset Voltage @ zero differential pressure	--	--	±0.3	mV
Offset Temperature Shift (0°C-70°C), note 2	--	--	±250	uV
Linearity, hysteresis error, note 3	--	0.1	0.25	%FSS
Span Temperature Shift (0°C-70°C), note 2	--	--	±1.0	%FSS

Performance Characteristics for: 15 PSI-A-PRIME-MINI , 15 PSI-AF-PRIME-MINI

Parameter, note 1	Minimum	Nominal	Maximum	Units
Output Span, note 4	89.1	90.0	90.9	mV
Offset Voltage @ zero absolute pressure	--	--	±0.5	mV
Offset Temperature Shift (0°C-70°C), note 2	--	--	±250	uV
Linearity, hysteresis error, note 3	--	0.1	0.3	%FSS
Span Temperature Shift (0°C-70°C), note 2	--	--	±1.0	%FSS

Performance Characteristics for: 15 PSI-G-PRIME-MINI , 15 PSI-GF-PRIME-MINI , 15 PSI-D-PRIME-MINI

Parameter, note 1	Minimum	Nominal	Maximum	Units
Output Span, note 4	89.1	90.0	90.9	mV
Offset Voltage @ zero differential pressure	--	--	±0.3	mV
Offset Temperature Shift (0°C-70°C), note 2	--	--	±250	uV
Linearity, hysteresis error, note 3	--	0.15	0.30	%FSS
Span Temperature Shift (0°C-70°C), note 2	--	--	±1.0	%FSS

Performance Characteristics for: 30 PSI-A-PRIME-MINI , 30 PSI-AF-PRIME-MINI

Parameter, note 1	Minimum	Nominal	Maximum	Units
Output Span, note 4	89.1	90.0	90.9	mV
Offset Voltage @ zero absolute pressure	--	--	±0.5	mV
Offset Temperature Shift (0°C-70°C), note 2	--	--	±250	uV
Linearity, hysteresis error, note 3	--	0.15	0.30	%FSS
Span Temperature Shift (0°C-70°C), note 2	--	--	±1.0	%FSS

Performance Characteristics for: 30 PSI-G-PRIME-MINI , 30 PSI-GF-PRIME-MINI , 30 PSI-D-PRIME-MINI

Parameter, note 1	Minimum	Nominal	Maximum	Units
Output Span, note 4	89.1	90.0	90.9	mV
Offset Voltage @ zero differential pressure	--	--	±0.3	mV
Offset Temperature Shift (0°C-70°C), note 2	--	--	±250	uV
Linearity, hysteresis error, note 3	--	0.15	0.30	%FSS
Span Temperature Shift (0°C-70°C), note 2	--	--	±1.0	%FSS

Performance Characteristics for: 100 PSI-A-PRIME-MINI, 100 PSI-AF-PRIME-MINI

Parameter, note 1	Minimum	Nominal	Maximum	Units
Output Span, note 4	99.0	100.0	101.0	mV
Offset Voltage @ zero absolute pressure	--	--	±0.5	mV
Offset Temperature Shift (0°C-70°C), note 2	--	--	±250	uV
Linearity, hysteresis error, note 3	--	0.15	0.30	%FSS
Span Temperature Shift (0°C-70°C), note 2	--	--	±1.0	%FSS

Performance Characteristics for: 100 PSI-G-PRIME-MINI , 100 PSI-GF-PRIME-MINI

Parameter, note 1	Minimum	Nominal	Maximum	Units
Output Span, note 4	99.0	100.0	101.0	mV
Offset Voltage @ zero differential pressure	--	--	±0.3	mV
Offset Temperature Shift (0°C-70°C), note 2	--	--	±250	uV
Linearity, hysteresis error, note 3	--	0.15	0.30	%FSS
Span Temperature Shift (0°C-70°C), note 2	--	--	±1.0	%FSS

Specification Notes

NOTE 1: ALL PARAMETERS ARE MEASURED AT 12.0 VOLT EXCITATION, FOR THE NOMINAL FULL SCALE PRESSURE AND ROOM TEMPERATURE UNLESS OTHERWISE SPECIFIED. PRESSURE MEASUREMENTS ARE WITH POSITIVE PRESSURE APPLIED TO PORT B.

NOTE 2: SHIFT IS RELATIVE TO 25°C.

NOTE 3: MEASURED AT ONE-HALF FULL SCALE RATED PRESSURE USING BEST STRAIGHT LINE CURVE FIT.

NOTE 4: THE SPAN IS THE ALGEBRAIC DIFFERENCE BETWEEN FULL SCALE OUTPUT VOLTAGE AND THE OFFSET VOLTAGE.

Pressure Response: for any pressure applied the response time to get to 90% of pressure applied is typically less than 100 useconds.

All Sensors reserves the right to make changes to any products herein. All Sensors does not assume any liability arising out of the application or use of any product or circuit described herein, neither does it convey any license under its patent rights nor the rights of others.

Equivalent Circuit

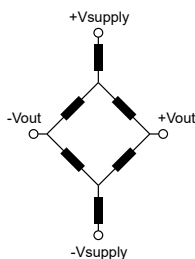

Input Resistance 5.0 k ohm
 Output Resistance 3.0 k ohm

Miniature Prime Grade Pressure Sensors

Packages

CFNS Package

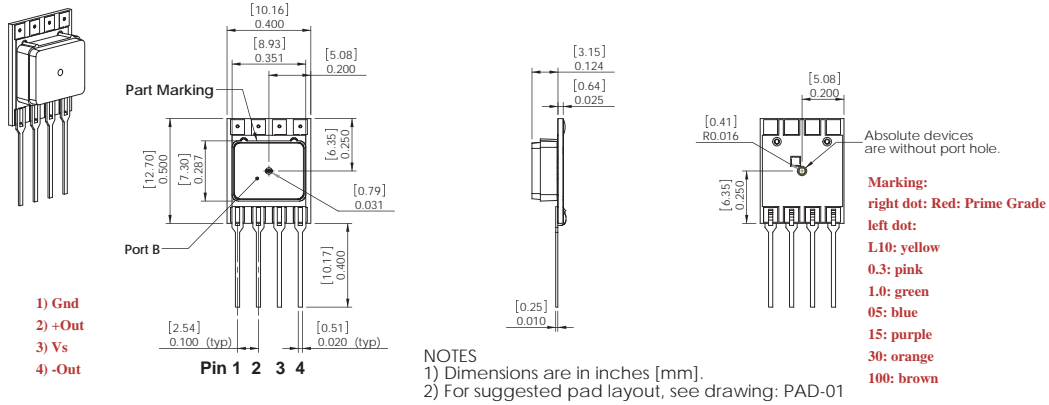

CPNS Package

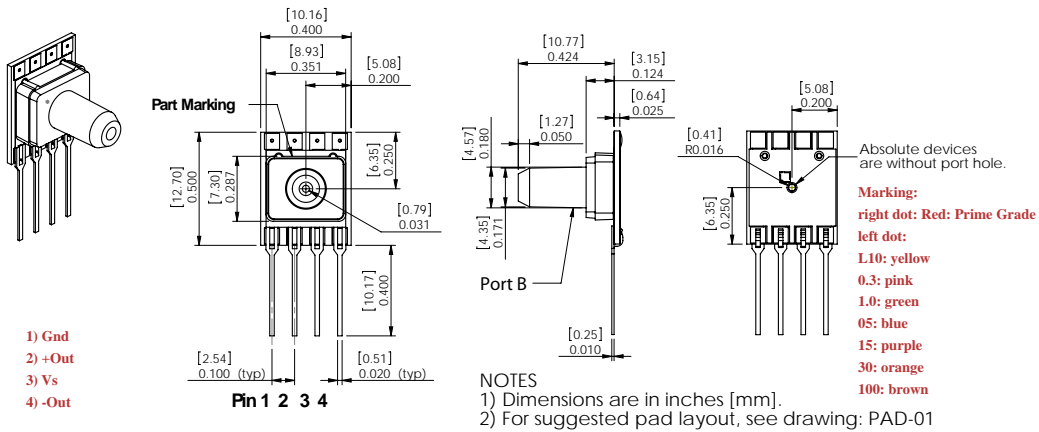

CPPS Package

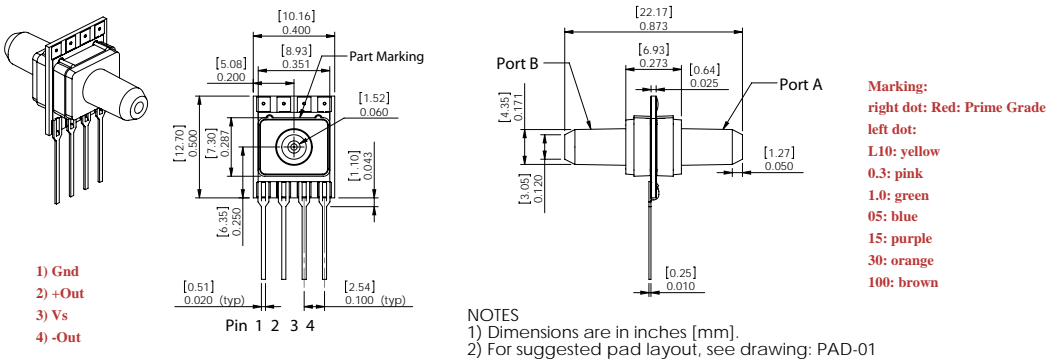

MINIATURE PRESSURE SENSORS

Barometric Pressure Sensors Prime Grade



Features

- 600 to 1,100 mbar Pressure Range
- 0.25 % linearity
- Temperature Compensated
- Calibrated Zero and Span

Applications

- Medical Instrumentation
- Environmental Controls
- Weather Station
- Altimeters

General Description

The Miniature series pressure sensors are based upon a proprietary technology to reduce the size of the sensor and yet maintain a high level of performance. This model provides a calibrated millivolt output with superior output characteristics. In addition the sensor utilizes a silicon, micromachined (MEMS) structure to provide a very linear output to measured pressure.

These calibrated and temperature compensated sensors give an accurate and stable output over a wide temperature range. This series is intended for use with non-corrosive, non-ionic working fluids such as air, dry gases and the like. The PRIME GRADE is the highest accuracy version of the millivolt output pressure sensors.

The output of the device is ratiometric to the supply voltage and operation from any D.C. supply voltage to 16 volts.

Pressure Sensor Characteristics Maximum Ratings	Environmental Specifications
Supply Voltage VS 16 Vdc Lead Temperature (soldering 2-4 sec.) 270°C	Temperature Ranges Compensated 0 to 70° C Operating -25 to 85° C Storage -40 to 125° C Humidity Limits 0 to 95% RH (non condensing)

Equivalent Circuit

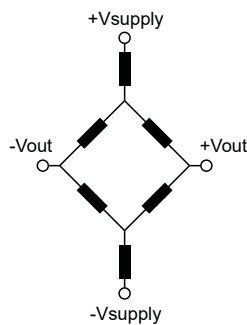

Input Resistance 15.0 k ohm
 Output Resistance 3.0 k ohm

Approvals

MKT	DATE	MFG	DATE	ENG	DATE	QA	DATE
<input type="checkbox"/> As Is <input type="checkbox"/> With Change		<input type="checkbox"/> As Is <input type="checkbox"/> With Change		<input type="checkbox"/> As Is <input type="checkbox"/> With Change		<input type="checkbox"/> As Is <input type="checkbox"/> With Change	

ALL SENSORS

DS-0039 Rev C

01

Standard Pressure Ranges

Part Number	Operating Range	Proof Pressure	Burst Pressure
BARO-A-PRIME-MINI	600 to 1100 mbar	45 PSI	60 PSI
BARO-AF-PRIME-DIP-MINI	600 to 1100 mbar	45 PSI	60 PSI
BARO-AF-PRIME-MINI	600 to 1100 mbar	45 PSI	60 PSI

Performance Characteristics

BARO-A-PRIME-MINI, BARO-AF-PRIME-DIP-MINI, BARO-AF-PRIME-MINI

Parameter, note 1	Minimum	Nominal	Maximum	Units
Output Voltage @ 1100 mbar	94.7	95.7	96.7	mV
Output Voltage @ 600 mbar	51.2	52.2	53.2	mV
Output Voltage 0 to 1100 mbar	--	0.087	--	mV/mbar
Linearity, hysteresis error, note 3	--	0.05	0.25	%fs
Output Shift (0°C-70°C), note 2	--	--	±1	%fs

Specification Notes

NOTE 1: ALL PARAMETERS ARE MEASURED AT 12.0 VOLT EXCITATION, FOR THE NOMINAL FULL SCALE PRESSURE AND ROOM TEMPERATURE UNLESS OTHERWISE SPECIFIED. PRESSURE MEASUREMENTS ARE WITH POSITIVE PRESSURE APPLIED TO PORT B.

NOTE 2: SHIFT IS RELATIVE TO 25°C.

NOTE 3: MEASURED AT ONE-HALF FULL SCALE RATED PRESSURE USING BEST STRAIGHT LINE CURVE FIT.

All Sensors reserves the right to make changes to any products herein. All Sensors does not assume any liability arising out of the application or use of any product or circuit described herein, neither does it convey any license under its patent rights nor the rights of others.

Physical Dimensions

CFNS Package

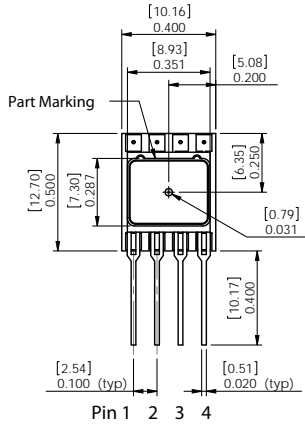
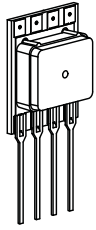

PINOUT:
 1: -Vs
 2: +Vout
 3: +Vs
 4: -Vout

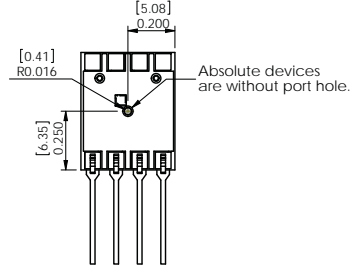
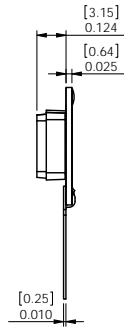

NOTES
 1) Dimensions are in inches [mm].
 2) For suggested pad layout, see drawing: PAD-01

CPND Package

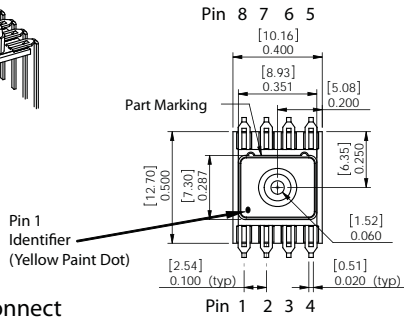
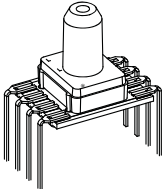

PINOUT:
 1: -Vs
 2: +Vout
 3: +Vs
 4: -Vout
 5: Do Not Connect
 6: Do Not Connect
 7: Do Not Connect
 8: Do Not Connect

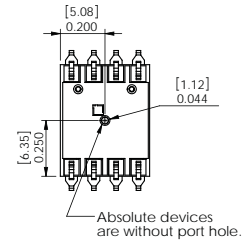
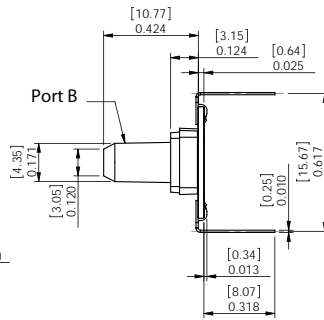

NOTES
 1) Dimensions are in inches [mm].
 2) For suggested pad layout, see drawing: PAD-03

CPNS Package

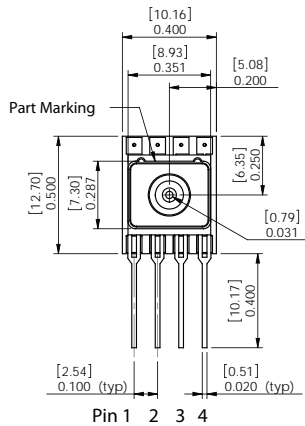
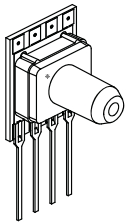

PINOUT:
 1: -Vs
 2: +Vout
 3: +Vs
 4: -Vout

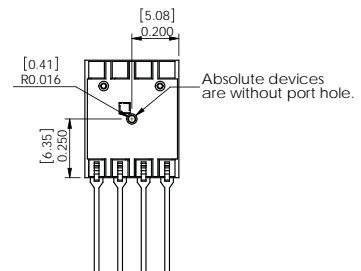
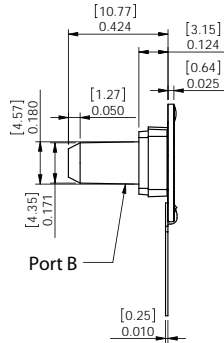

NOTES
 1) Dimensions are in inches [mm].
 2) For suggested pad layout, see drawing: PAD-01

Digital Output

DLH SERIES LOW VOLTAGE DIGITAL PRESSURE SENSORS

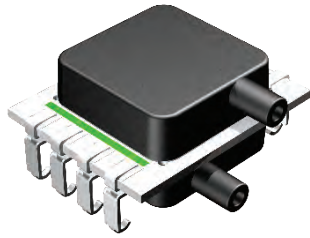

Features

- 5 to 60 inH2O Pressure Ranges
- 1.68V to 3.6V Supply Voltage Range
- I2C or SPI Interface (Automatically Selected)
- Better than 0.25% Accuracy
- High Resolution 16/17/18 bit Output

Applications

- Medical Breathing
- Environmental Controls
- HVAC
- Industrial Controls
- Portable/Hand-Held Equipment

General Description

The DLH Series Mini Digital Output Sensor is based on All Sensors' CoBeam²™ Technology. This reduces package stress susceptibility, resulting in improved overall long term stability and vastly improves the position sensitivity.

The digital interface options ease integration of the sensors into a wide range of process control and measurement systems, allowing direct connection to serial communications channels. For battery-powered systems, the sensors can enter very low-power modes between readings to minimize load on the power supply.

These calibrated and compensated sensors provide accurate, stable output over a wide temperature range. This series is intended for use with non-corrosive, non-ionic working fluids such as air, dry gases and the like. A protective parylene coating is optionally available for moisture/harsh media protection.

Standard Pressure Ranges					Equivalent Circuit	
Device	Operating Range	Proof Pressure	Burst Pressure	Nominal Span		
DLH-L05D	±5 inH2O	200 inH2O	300 inH2O	±0.4 * 2 ²⁴ counts		
DLH-L10D	±10 inH2O	200 inH2O	300 inH2O	±0.4 * 2 ²⁴ counts		
DLH-L20D	±20 inH2O	200 inH2O	500 inH2O	±0.4 * 2 ²⁴ counts		
DLH-L30D	±30 inH2O	200 inH2O	500 inH2O	±0.4 * 2 ²⁴ counts		
DLH-L60D	±60 inH2O	200 inH2O	800 inH2O	±0.4 * 2 ²⁴ counts		
DLH-L05G	0 to 5 inH2O	200 inH2O	300 inH2O	0.8 * 2 ²⁴ counts		
DLH-L10G	0 to 10 inH2O	200 inH2O	300 inH2O	0.8 * 2 ²⁴ counts		
DLH-L20G	0 to 20 inH2O	200 inH2O	500 inH2O	0.8 * 2 ²⁴ counts		
DLH-L30G	0 to 30 inH2O	200 inH2O	500 inH2O	0.8 * 2 ²⁴ counts		
DLH-L60G	0 to 60 inH2O	200 inH2O	800 inH2O	0.8 * 2 ²⁴ counts		

Pressure Sensor Maximum Ratings		Environmental Specifications		
Supply Voltage (Vs)	3.63 Vdc	Temperature Ranges		
Common Mode Pressure	10 psig	Compensated:	Commercial	0°C to 70°C
Lead Temperature (soldering 2-4 sec.)	270 °C	Operating Storage	Industrial	-20°C to 85°C
				-25°C to 85 °C
				-40°C to 125 °C
		Humidity Limits (non condensing)		0 to 95% RH

Performance Characteristics for DLH Series - Commercial and Industrial Temperature Range

ALL PARAMETERS ARE MEASURED AT 3.3V ±5% EXCITATION AND 25C UNLESS OTHERWISE SPECIFIED (NOTE 9). PRESSURE MEASUREMENTS ARE WITH POSITIVE PRESSURE APPLIED TO PORT B.

Parameter	Min	Typ	Max	Units	Notes
Output Span (FSS)					1
LxD	-	±0.4 * 2 ²⁴	-	Dec Count	
LxG	-	0.8 * 2 ²⁴	-	Dec Count	
Offset Output @ Zero Diff. Pressure (OS_{dig})					-
LxD	-	0.5 * 2 ²⁴	-	Dec Count	
LxG	-	0.1 * 2 ²⁴	-	Dec Count	
Total Error Band					2
L01x, L02x	-	±0.75	±1.5	%FSS	
L05x, L10x, L20x, L30x, L60x	-	±0.50	±1.0	%FSS	
Span Temperature Shift	-	±0.25	-	%FSS	3
Offset Temperature Shift	-	±0.25	-	%FSS	3
Offset Warm-up Shift	-	±0.20	-	%FSS	4
Offset Position Sensitivity (±1g)	-	±0.10	-	%FSS	-
Offset Long Term Drift (One Year)	-	±0.30	-	%FSS	-
Linearity, Hysteresis Error					6
LxD	-	±0.25	-	%FSS	
LxG	-	±0.10	-	%FSS	
Pressure Digital Resolution - No Missing Codes					-
16-bit Option	15.3	15.5	-	bit	
17-bit Option	16.3	16.5	-	bit	
18-bit Option	17.0	17.5	-	bit	
Temperature Output					-
Resolution	-	16	-	bit	
Overall Accuracy	-	2	-	°C	
Supply Current Requirement					5, 7, 8
During Active State (I _{CC Active})	-	1.5	2.0	mA	
During Idle State (I _{CC Idle})	-	100	250	nA	
Power On Delay	-	-	2.5	ms	5
Data Update Time (t_{DU})	(see table below)			ms	5, 7

Calibrated Resolution	Measurement Command										Units
	Single		Average2		Average4		Average8		Average16		
	Typ	Max	Typ	Max	Typ	Max	Typ	Max	Typ	Max	
16 bit option	2.80	3.1	5.40	6.0	10.60	11.7	21.00	23.2	41.80	46.0	ms
17 bit option	3.20	3.6	6.20	6.9	12.20	13.5	24.20	26.7	48.20	53.1	ms
18 bit option	3.70	4.1	7.20	8.0	14.20	15.7	28.20	31.1	56.20	61.9	ms

See the following page for performance characteristics notes.

I2C / SPI Electrical Parameters for DLH Series

Parameter	Symbol	Min	Typ	Max	Units	Notes
Input High Level	-	80.0	-	100	% of Vs	5
Input Low Level	-	0	-	20.0	% of Vs	5
Output Low Level	-	-	-	10.0	% of Vs	5
I2C Pull-up Resistor	-	1000	-	-	Ω	5
I2C Load Capacitance on SDA, @ 400 kHz	C _{SDA}	-	-	200	pF	5
I2C Input Capacitance (each pin)	C _{I2C_IN}	-	-	10.0	pF	5
I2C Address			41		decimal	

Pressure Output Transfer Function

$$Pressure(inH_2O) = 1.25 \times \left(\frac{P_{out_{dig}} - OS_{dig}}{2^{24}} \right) \times FSS(inH_2O)$$

Where:

$P_{out_{dig}}$ Is the sensor 24-bit digital output.

OS_{dig} Is the specified digital offset
 For Gage Operating Range sensors: $0.1 * 2^{24}$
 For Differential Operating Range sensors: $0.5 * 2^{24}$

$FSS(inH_2O)$ The sensor Full Scale Span in inches H₂O
 For Gage Operating Range sensors: Full Scale Pressure
 For Differential Operating Range sensors: 2 x Full Scale Pressure.

Temperature Output Transfer Function

$$Temperature (°C) = \left(\frac{T_{out_{dig}} * 125}{2^{24}} \right) - 40$$

Where:

$T_{out_{dig}}$ The sensor 24-bit digital temperature output.
 (Note that only the upper 16 bits are significant)

Specification Notes

- NOTE 1: THE SPAN IS THE ALGEBRAIC DIFFERENCE BETWEEN FULL SCALE DECIMAL COUNTS AND THE OFFSET DECIMAL COUNTS.
- NOTE 2: TOTAL ERROR BAND CONSISTS OF OFFSET AND SPAN TEMPERATURE AND CALIBRATION ERRORS, LINEARITY AND PRESSURE HYSTERESIS ERRORS, OFFSET WARM-UP SHIFT, OFFSET POSITION SENSITIVITY AND LONG TERM OFFSET DRIFT ERRORS.
- NOTE 3: SHIFT IS RELATIVE TO 25C.
- NOTE 4: SHIFT IS WITHIN THE FIRST HOUR OF EXCITATION APPLIED TO THE DEVICE.
- NOTE 5: PARAMETER IS CHARACTERIZED AND NOT 100% TESTED.
- NOTE 6: MEASURED AT ONE-HALF FULL SCALE RATED PRESSURE USING BEST STRAIGHT LINE CURVE FIT.
- NOTE 7: DATA UPDATE TIME IS EXCLUSIVE OF COMMUNICATIONS, FROM COMMAND RECEIVED TO END OF BUSY STATUS. THIS CAN BE OBSERVED AS EOC PIN LOW- STATE DURATION.
- NOTE 8: AVERAGE CURRENT CAN BE ESTIMATED AS : $ICC_{idle} + (t_{DU} / \text{READING INTERVAL}) * ICC_{Active}$. REFER TO FIGURE 2 FOR ACTIVE AND IDLE CONDITIONS OF THE SENSOR (THE ACTIVE STATE IS WHILE EOC PIN IS LOW).
- NOTE 9: THE SENSOR IS CALIBRATED WITH A 3.3V SUPPLY HOWEVER, AN INTERNAL REGULATOR ALLOWS A SUPPLY VOLTAGE OF 1.68V TO 3.6V TO BE USED WITHOUT AFFECTING THE OVERALL SPECIFICATIONS. THIS ALLOWS DIRECT OPERATION FROM A BATTERY SUPPLY.

Device Ordering Options

Output Resolution

Calibrated output resolution can be ordered to be 16, 17, or 18 bits. Higher resolution results in slower update times; see the Data Update Time in the Performance Characteristics table.

Coating

Parylene Coating: Parylene coating provides a moisture barrier and protection form some harsh media. Consult factory for applicability of Parylene for the target application and sensor type.

Operation Overview

The DLH is a digital sensor with a signal path that includes a sensing element, a variable-bit analog to digital converter, a DSP and an I/O block that supports either an I2C or SPI interface (see Figure 1 below). The sensor also includes an internal temperature reference and associated control logic to support the configured operating mode. Since there is a single ADC, there is also a multiplexer at the front end of the ADC that selects the signal source for the ADC.

Figure 1 - DLH Essential Model

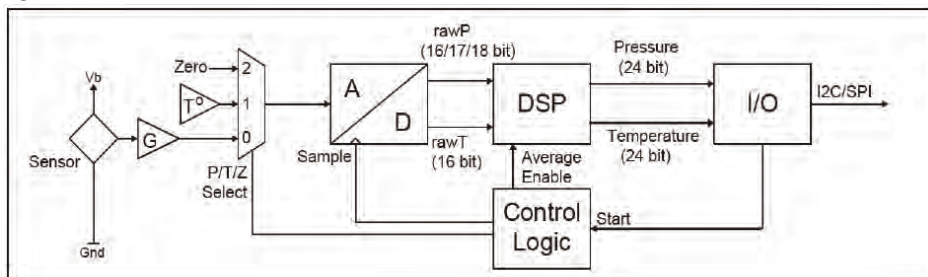

The ADC performs conversions on the raw sensor signal (P), the temperature reference (T) and a zero reference (Z) during the ADC measurement cycle.

The DSP receives the converted pressure and temperature information and applies a multi-order transfer function to compensate the pressure output. This transfer function includes compensation for span, offset, temperature effects on span, temperature effects on offset and second order temperature effects on both span and offset. There is also linearity compensation for gage devices and front to back linearity compensation for differential devices.

Sensor Commands: Five Measurement commands are supported, returning values of either a single pressure / temperature reading or an average of 2, 4, 8, or 16 readings. Each of these commands wakes the sensor from Idle state into Active state, and starts a measurement cycle. For the Start-Average commands, this cycle is repeated the appropriate number of times, while the Start-Single command performs a single iteration. When the DSP has completed calculations and the new values have been made available to the I/O block, the sensor returns to Idle state. The sensor remains in this low-power state until another Measurement command is received.

After completion of the measurement, the result may then be read using the Data Read command. The ADC and DSP remain in Idle state, and the I/O block returns the 7 bytes of status and measurement data. See Figure 2, following. At any time, the host may request current device status with the Status Read command. See Table 1 for a summary of all commands.

For optimum sensor performance, All Sensors recommends that Measurement commands be issued at a fixed interval by the host system. Irregular request intervals may increase overall noise on the output. *Furthermore, if reading intervals are much slower than the Device Update Time, using the Averaging commands is suggested to reduce offset shift. This shift is constant with respect to time interval, and may be removed by the application. For longer fixed reading intervals, this shift may be removed by the factory on special request.*

I/O Interface Configuration: The sensor automatically selects SPI or I2C serial interface, based on the following protocol: If the /SS input is set low by the host (as occurs during a SPI command transaction), the I/O interface will remain configured for SPI communications until power is removed. Otherwise, once a valid device address and command have been received over the I2C interface, the I/O interface will remain configured for I2C until power is removed.

NOTE: The four-pin (SIP) packages only support the I2C interface.

Operation Overview

Figure 2 - DLH Communication Model

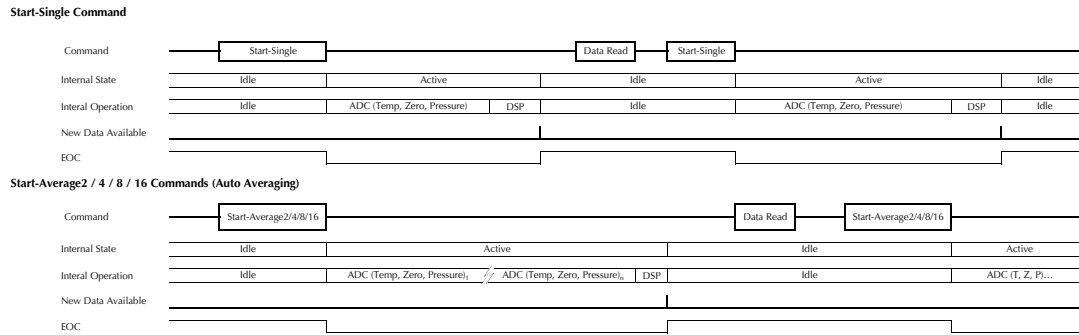

Digital Interface Command Formats

When requesting the start of a measurement, the command length for I2C is 1 byte, for SPI it is 3 bytes.
 When requesting sensor status over I2C, the host simply performs a 1-byte read transfer.
 When requesting sensor status over SPI, the host **MUST** send the Status Read command byte while reading 1 byte.
 When reading sensor data over I2C, the host simply performs a 7-byte read transfer.
 When reading sensor data over SPI, the host **MUST** send the 7-byte Data Read command while reading the data.
SENDING UNDOCUMENTED COMMANDS TO SENSOR WILL CORRUPT CALIBRATION AND IS NOT COVERED BY WARRANTY.

See Table 1 below for Measurement Commands, Sensor Data read and Sensor Status read details.

Table 1 - DLH Sensor Command Set

Measurement Commands				
Description	SPI (3 bytes)			I2C (1 byte)
Start-Single	0xAA	0x00	0x00	0xAA
Start-Average2	0xAC	0x00	0x00	0xAC
Start-Average4	0xAD	0x00	0x00	0xAD
Start-Average8	0xAE	0x00	0x00	0xAE
Start-Average16	0xAF	0x00	0x00	0xAF

Read Sensor Data	
I2C	Read of 7 bytes from device
SPI	Read of 7 bytes from device Host must send [0xF0], then 6 bytes of [0x00] on MOSI Sensor Returns 7 bytes on MISO

Read Sensor Status	
I2C	Read of 1 byte from device.
SPI	Read of 1 byte from device Host must send [0xF0] on MOSI Sensor Returns 1 byte on MISO

Digital Interface Data Format

For either type of digital interface, the format of data returned from the sensor is the same. The first byte consists of the Status Byte followed by a 24-bit unsigned pressure value and a 24-bit unsigned temperature value. Unused bits beyond the calibrated bit width are undefined, and may have any value. See the Pressure Output Transfer Function and Temperature Output Transfer Function definitions on page 3 for converting to pressure and temperature. Refer to Table 2 for the overall data format of the sensor. Table 3 shows the Status Byte definition. Note that a completed reading without error will return status 0x40.

Table 2 - Output Data Format

S[7:0]	P[23:16]	P[15:8]	P[7:0]	T[23:16]	T[15:8]	T[7:0]
Status Byte	Pressure Byte 3	Pressure Byte 1	Pressure Byte 0	Temperature Byte 3	Temperature Byte 1	Temperature Byte 0

Table 3- Status Byte Definition

Bit	Description
Bit 7 [MSB]	[Always = 0]
6	Power : [1 = Power On]
5	Busy: [1 = Processing Command, 0 = Ready]
4:3	Mode: [00 = Normal Operation]
2	Memory Error [1 = EEPROM Checksum Fail]
1	Sensor Configuration [always = 0]
Bit 0 [LSB]	ALU Error [1 = Error]

I2C Interface

I2C Command Sequence

The part enters Idle state after power-up, and waits for a command from the bus master. Any of the five Measurement commands may be sent, as shown in Table 1. Following receipt of one of these command bytes, the EOC pin is set to Low level, and the sensor Busy bit is set in the Status Byte. After completion of measurement and calculation in the Active state, compensated data is written to the output registers, the EOC pin is set high, and the processing core goes back to Idle state. The host processor can then perform the Data Read operation, which for I2C is simply a 7-byte Device Read.

If the EOC pin is not monitored, the host can poll the Status Byte by repeating the Status Read command, which for I2C is a one-byte Device Read. When the Busy bit in the Status byte is zero, this indicates that valid data is ready, and a full Data Read of all 7 bytes may be performed.

DO NOT SEND COMMANDS TO SENSOR OTHER THAN THOSE DEFINED IN TABLE 1.

I2C Interface (Cont'd)

I2C Bus Communications Overview

The I2C interface uses a set of signal sequences for communication. The following is a description of the supported sequences and their associated mnemonics. Refer to Figure 3 for the associated usage of the following signal sequences.

Bus not Busy (I): During idle periods both data line (SDA) and clock line (SCL) remain HIGH.

START condition (ST): A HIGH to LOW transition of SDA line while the clock (SCL) is HIGH is interpreted as START condition. START conditions are always set by the master. Each initial request for a pressure value has to begin with a START condition.

Slave address (An): The I²C-bus requires a unique address for each device. The DLH sensor has a preconfigured slave address (see specification table on Page 3). After setting a START condition the master sends the address byte containing the 7 bit sensor address followed by a data direction bit (R/W). A "0" indicates a transmission from master to slave (WRITE), a "1" indicates a device-to master request (READ).

Acknowledge (A or N): Data is transferred in units of 8 bits (1 byte) at a time, MSB first. Each data-receiving device, whether master or slave, is required to pull the data line LOW to acknowledge receipt of the data. The Master must generate an extra clock pulse for this purpose. If the receiver does not pull the data line down, a NACK condition exists, and the slave transmitter becomes inactive. The master determines whether to send the last command again or to set the STOP condition, ending the transfer.

DATA valid (Dn): State of data line represents valid data when, after a START condition, data line is stable for duration of HIGH period of clock signal. Data on line must be changed during LOW period of clock signal. There is one clock pulse per data bit.

STOP condition (P): LOW to HIGH transition of the SDA line while clock (SCL) is HIGH indicates a STOP condition. STOP conditions are always generated by the master.

Figure 3 - I2C Communication Diagram

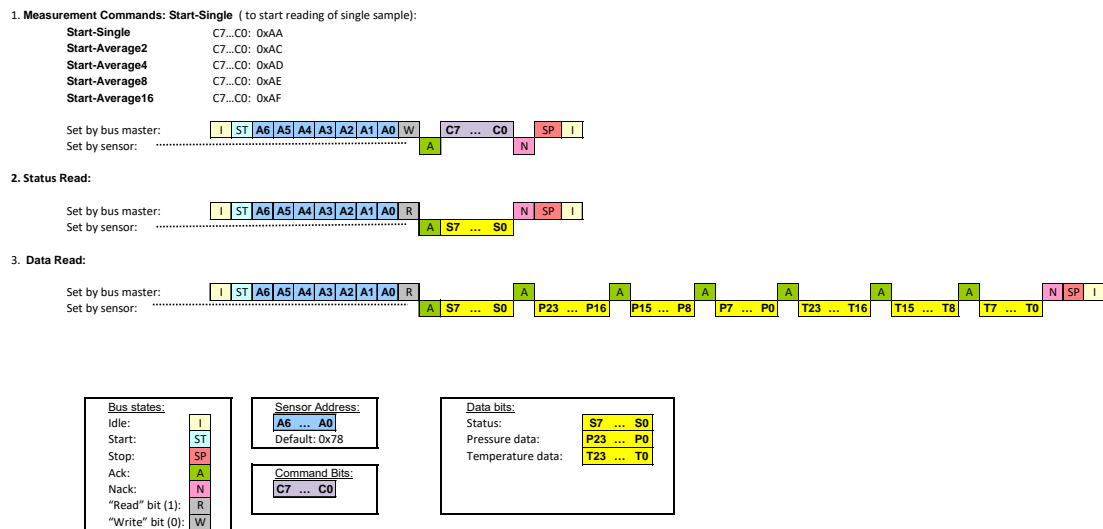

SPI Interface

SPI Command Sequence

As with the I2C interface configuration, the part enters Idle state after power-up, and waits for a command from the SPI master. To start a measurement cycle, one of the 3- byte Measurement Commands (see Table 1) must be issued by the master. The data returned by the sensor during this command request consists of the Status Byte followed by two undefined data bytes. On successful decode of the command, the EOC pin is set Low as the core goes into Active state for measurement and calculation. When complete, updated sensor data is written to the output registers, and the core goes back to the Idle state. The EOC pin is set to a High level at this point, and the Busy status bit is set to 0. At any point during the Active or Idle periods, the SPI master can request the Status Byte by sending a Status Read command (a single byte with value 0xF0). As with the I2C configuration, a Busy bit of value 0 in the Status Byte or a high level on the EOC pin indicates that a valid data set may be read from the sensor. The Data Read command must be sent from the SPI master (The first byte of value 0xF0 followed by 6 bytes of 0x00).

NOTE: Sending commands that are not defined in Table 1 will corrupt sensor operation.

SPI Bus Communications Overview

The sequence of bits and bus signals are shown in the following illustration (Figure 4). Refer to Figure 5 in the Interface Timing Diagram section for detailed timing data.

Figure 4 - SPI Communications Diagram

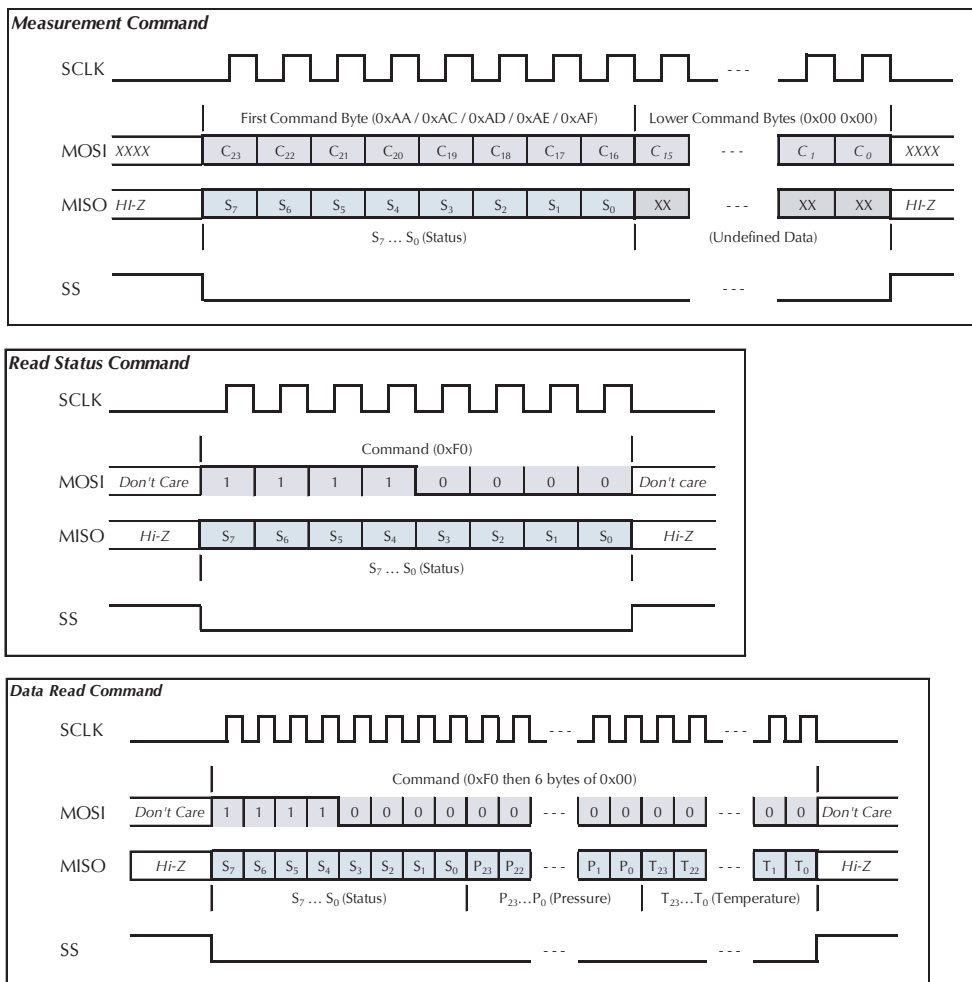

Interface Timing Diagrams

Figure 5 - SPI Timing Diagram

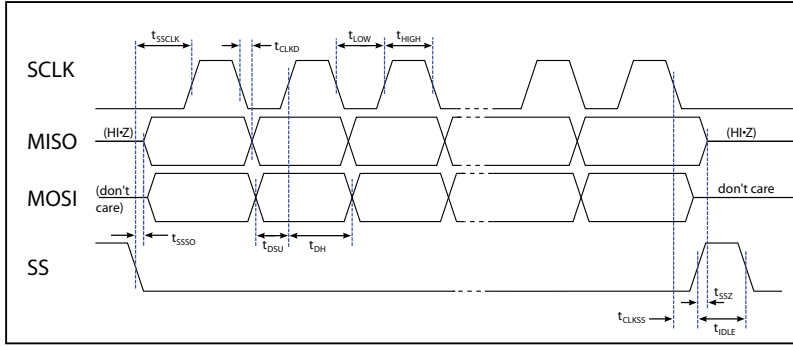

PARAMETER	SYMBOL	MIN	TYP	MAX	UNITS
SCLK frequency ⁽¹⁾	f _{SCLK}	0.05	-	5	MHz
SS low to first clock edge	t _{SSCLK}	120	-	-	ns
SS low to serial out	t _{SSSO}	--	-	20	ns
Clock to data out	t _{CLKD}	8	-	32	ns
SCLK low width	t _{LOW}	100	-	-	ns
SCLK high width	t _{HIGH}	100	-	-	ns
Data setup to clock	t _{DSU}	50	-	-	ns
Data hold after clock	t _{DH}	50	-	-	ns
Last clock to rising SS	t _{CLKSS}	0	-	-	ns
SS high to output hi-Z	t _{SSZ}	--	-	20	ns
Bus idle time	t _{IDLE}	250	-	-	ns

(1) Maximum by design, tested to 1.0 MHz.

Figure 6 - I2C Timing Diagram

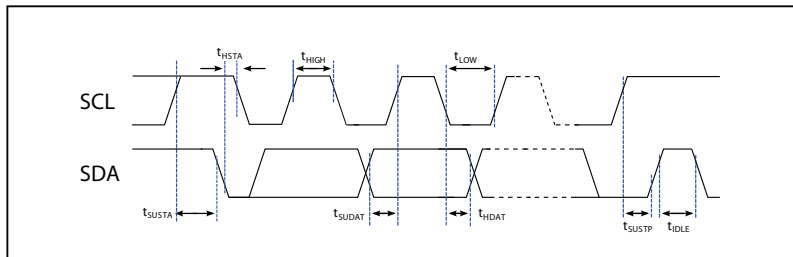

PARAMETER	SYMBOL	MIN	TYP	MAX	UNITS
SCL frequency	f _{SCL}	100	-	400	KHz
SCL low width	t _{LOW}	1.3	-	-	us
SCL high width	t _{HIGH}	0.6	-	-	us
Start condition setup	t _{SUSTA}	0.6	-	-	us
Start condition hold	t _{HSTA}	0.6	-	-	us
Data setup to clock	t _{SUDAT}	0.1	-	-	us
Data hold to clock	t _{HDAT}	0	-	-	us
Stop condition setup	t _{SUSTP}	0.6	-	-	us
Bus idle time	t _{IDLE}	2.0	-	-	us

How to Order

Refer to Table 4 for configuring a standard base part number which includes the pressure range, package and temperature range. Table 5 shows the available configuring options. The option identifier is required to complete the device part number. Refer to Table 6 for the available device packages.

Example P/N with options: DLH-L05D-E1NS-C-NAV6

Table 4 - How to configure a base part







ORDERING INFORMATION	SERIES	PRESSURE RANGE		PACKAGE						TEMPERATURE RANGE		
	ID	ID	Description	Base		Port Orientation		Lid Style		Lead Type		
				ID	Description	ID	Description	ID	Description	ID	Description	
	DLH	L05D	±5 inH2O	E	1	Dual Port Same Side	N	Non-Barbed	S	SIP	C	Commercial
		L10D	±10 inH2O		2	Dual Port Opposite Side	B	Barbed	D	DIP	I	Industrial
		L20D	±20 inH2O						J	J-Lead SMT		
		L30D	±30 inH2O									
		L60D	±60 inH2O									
		L05G	0 to 5 inH2O									
		L10G	0 to 10 inH2O									
		L20G	0 to 20 inH2O									
		L30G	0 to 30 inH2O									
		L60G	0 to 60 inH2O									
Example	DLH	L05D		E	1		N		S		C	

Table 5 - How to configure an option identifier

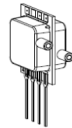
ORDERING INFORMATION	COATING		INTERFACE		SUPPLY VOLTAGE		RESOLUTION	
	ID	Description	ID	Description	ID	Description	ID	Description
	N	No Coating	A	Auto I2C/SPI	V	1.68V to 3.6V	6	16 Bit
P	Parylene Coating ⁽¹⁾					7	17 bit	
						8	18 bit	
Example	N		A		V		6	

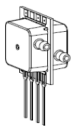
(1) Parylene coating not offered on J-Lead Configurations

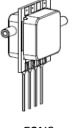
Table 6 - Available E-Series Package Configurations

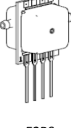
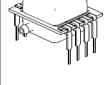
Port Orientation	Non-Barbed Lid Lead Style				Barbed Lid Lead Style			
	SIP ⁽¹⁾	DIP	J Lead SMT	Low Profile DIP	SIP ⁽¹⁾	DIP	J Lead SMT	Low Profile DIP
Dual Port Same Side	 E1NS	 E1ND	 E1NJ	N/A	 E1BS	 E1BD	N/A	N/A
Dual Port Opposite Side	 E2NS	 E2ND	 E2NJ	N/A	 E2BS	 E2BD	N/A	N/A
Single Port (Gage)	N/A	N/A	N/A	N/A	N/A	N/A	N/A	N/A

(1) SPI is not available in SIP packages

Package Drawings

E1NS Package

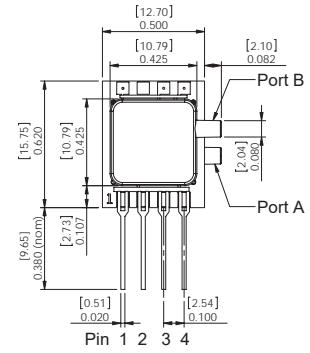
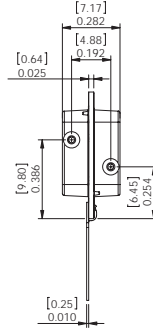
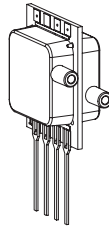

Pinout
 1) Gnd
 2) Vs
 3) SDA
 4) SCL

NOTES
 1) Dimensions are in inches (mm)
 2) For suggested pad layout, see drawing: PAD-01

E1BS Package

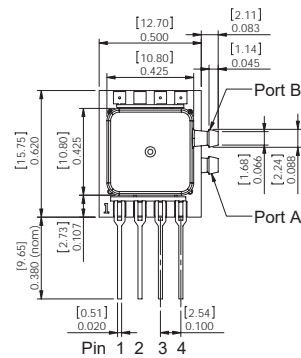
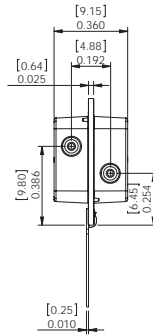
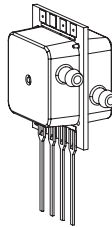

Pinout
 1) Gnd
 2) Vs
 3) SDA
 4) SCL

NOTES
 1) Dimensions are in inches (mm)
 2) For suggested pad layout, see drawing: PAD-01

Package Drawings (Cont'd)

E2NS Package

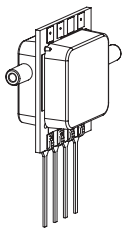

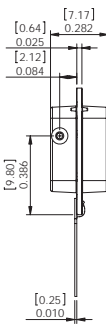

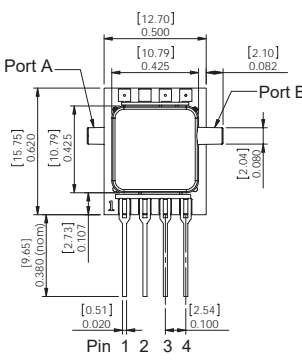

Pinout

- 1) Gnd
- 2) Vs
- 3) SDA
- 4) SCL

NOTES
 1) Dimensions are in inches [mm]
 2) For suggested pad layout, see drawing: PAD-01

E2BS Package

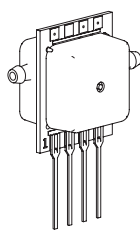

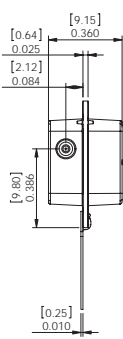

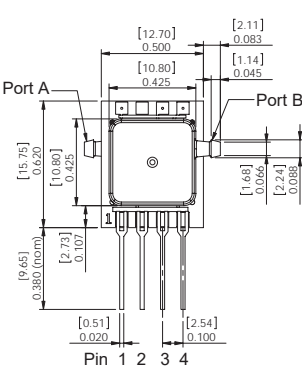

Pinout

- 1) Gnd
- 2) Vs
- 3) SDA
- 4) SCL

NOTES
 1) Dimensions are in inches [mm]
 2) For suggested pad layout, see drawing: PAD-01

Package Drawings (Cont'd)

E1ND Package

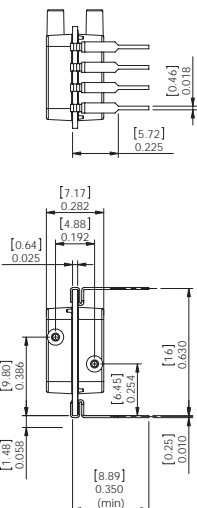
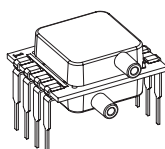

- Pinout**
- 1) Gnd
 - 2) Vs
 - 3) SDA/MOSI
 - 4) SCL/SCLK
 - 5) EOC
 - 6) MISO
 - 7) Not Connected
 - 8) /SS

NOTES
 1) Dimensions are in inches [mm]
 2) For suggested pad layout, see drawing: PAD-03

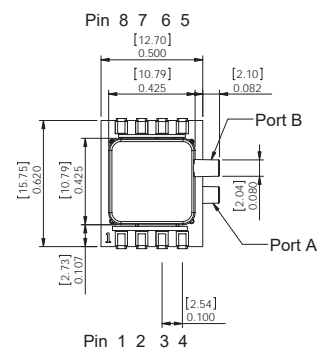

E1BD Package

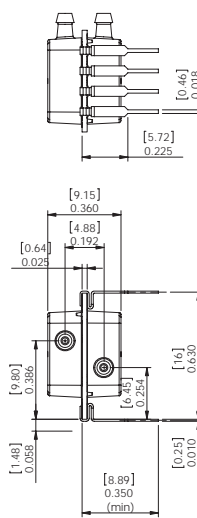
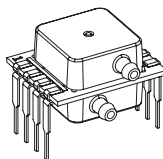

- Pinout**
- 1) Gnd
 - 2) Vs
 - 3) SDA/MOSI
 - 4) SCL/SCLK
 - 5) EOC
 - 6) MISO
 - 7) Not Connected
 - 8) /SS

NOTES
 1) Dimensions are in inches [mm]
 2) For suggested pad layout, see drawing: PAD-03

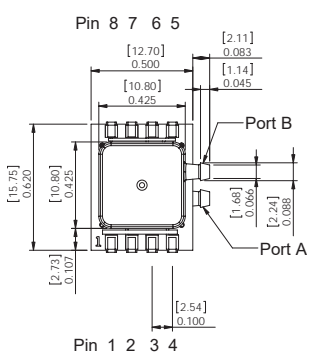

Package Drawings (Cont'd)

E2ND Package

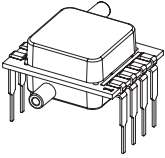
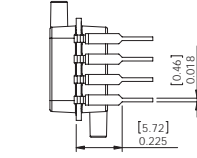
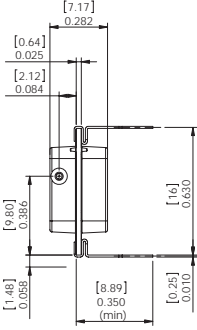
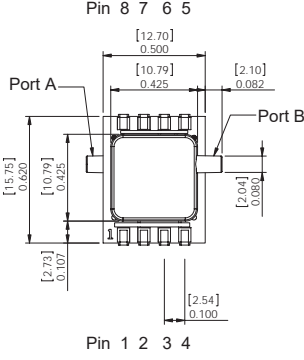
Pinout

- 1) Gnd
- 2) Vs
- 3) SDA/MOSI
- 4) SCL/SCLK
- 5) EOC
- 6) MISO
- 7) Not Connected
- 8) /SS

NOTES

- 1) Dimensions are in inches [mm]
- 2) For suggested pad layout, see drawing: PAD-03

E2BD Package

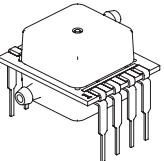
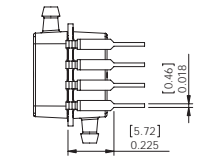
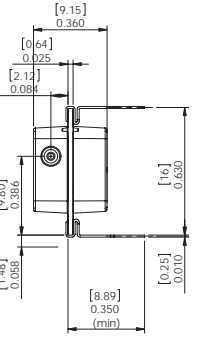
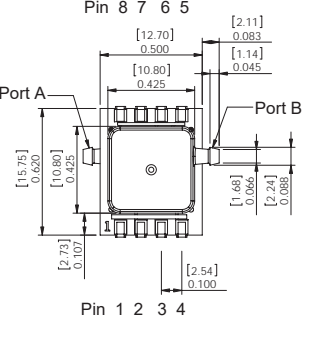
Pinout

- 1) Gnd
- 2) Vs
- 3) SDA/MOSI
- 4) SCL/SCLK
- 5) EOC
- 6) MISO
- 7) Not Connected
- 8) /SS

NOTES

- 1) Dimensions are in inches [mm]
- 2) For suggested pad layout, see drawing: PAD-03

Package Drawings (Cont'd)

E1NJ Package

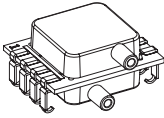
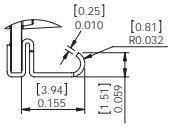
DETAIL A
SCALE 4 : 1

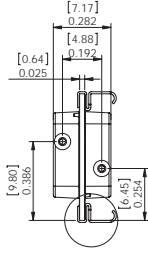

A

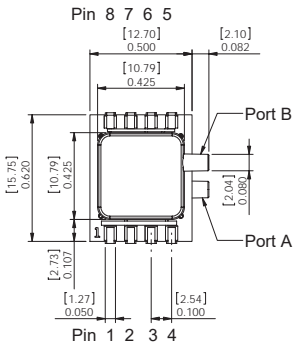

Pinout

- 1) Gnd
- 2) Vs
- 3) SDA/MOSI
- 4) SCL/SCLK
- 5) EOC
- 6) MISO
- 7) Not Connected
- 8) /SS

NOTES
 1) Dimensions are in inches [mm]
 2) For suggested pad layout, see drawing: PAD-10

E2NJ Package

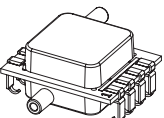
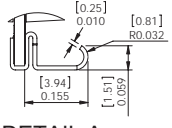
DETAIL A
SCALE 4 : 1

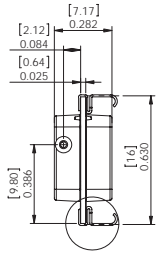

A

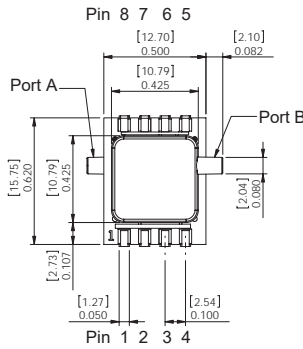

Pinout

- 1) Gnd
- 2) Vs
- 3) SDA/MOSI
- 4) SCL/SCLK
- 5) EOC
- 6) MISO
- 7) Not Connected
- 8) /SS

NOTES
 1) Dimensions are in inches [mm]
 2) For suggested pad layout, see drawing: PAD-10

Suggested Pad Layout

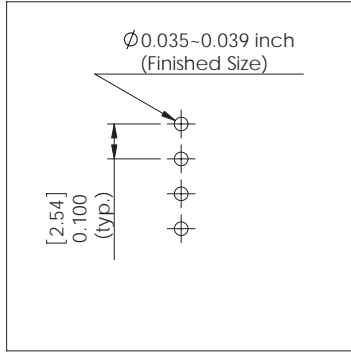

PAD-01

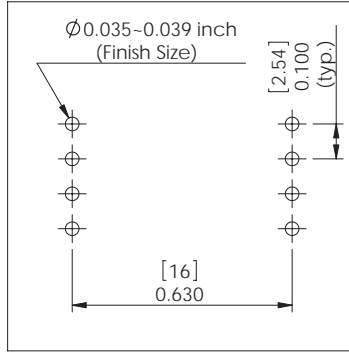

PAD-03

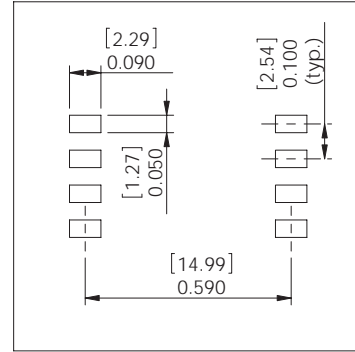

PAD-10

Product Labeling

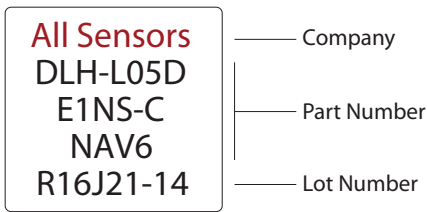

Example Device Label

All Sensors reserves the right to make changes to any products herein. All Sensors does not assume any liability arising out of the application or use of any product or circuit described herein, neither does it convey any license under its patent rights nor the rights of others.

DLHR SERIES LOW VOLTAGE DIGITAL PRESSURE SENSORS

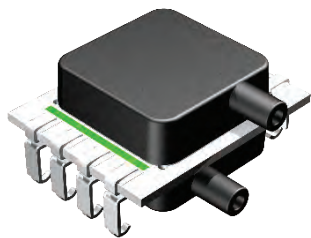

Features

- 0.5 to 60 inH2O Pressure Ranges
- 1.68V to 3.6V Supply Voltage Range
- I2C or SPI Interface (Automatically Selected)
- Better than 0.25% Accuracy
- High Resolution 16/17/18 bit Output

Applications

- Medical Breathing
- Environmental Controls
- HVAC
- Industrial Controls
- Portable/Hand-Held Equipment

General Description

The DLHR Series Mini Digital Output Sensor is based on All Sensors' CoBeam™ Technology. This reduces package stress susceptibility, resulting in improved overall long term stability and vastly improves the position sensitivity.

The digital interface eases integration of the sensors into a wide range of process control and measurement systems, allowing direct connection to serial communications channels. For battery-powered systems, the sensors can enter very low-power mode between readings to minimize load on the power supply.

These calibrated and compensated sensors provide accurate, stable output over a wide temperature range. This series is intended for use with non-corrosive, non-ionic working fluids such as air, dry gases and the like. A protective parylene coating is optionally available for moisture/harsh media protection.

Standard Pressure Ranges					Equivalent Circuit
Device	Operating Range	Proof Pressure	Burst Pressure	Nominal Span	
DLHR-F50D	±0.5 inH2O	100 inH2O	300 inH2O	±0.4 * 2 ²⁴ counts	
DLHR-L01D	±1 inH2O	100 inH2O	300 inH2O	±0.4 * 2 ²⁴ counts	
DLHR-L02D	±2 inH2O	100 inH2O	300 inH2O	±0.4 * 2 ²⁴ counts	
DLHR-L05D	±5 inH2O	200 inH2O	300 inH2O	±0.4 * 2 ²⁴ counts	
DLHR-L10D	±10 inH2O	200 inH2O	300 inH2O	±0.4 * 2 ²⁴ counts	
DLHR-L20D	±20 inH2O	200 inH2O	500 inH2O	±0.4 * 2 ²⁴ counts	
DLHR-L30D	±30 inH2O	200 inH2O	500 inH2O	±0.4 * 2 ²⁴ counts	
DLHR-L60D	±60 inH2O	200 inH2O	800 inH2O	±0.4 * 2 ²⁴ counts	
DLHR-L01G	0 to 1 inH2O	100 inH2O	300 inH2O	0.8 * 2 ²⁴ counts	
DLHR-L02G	0 to 2 inH2O	100 inH2O	300 inH2O	0.8 * 2 ²⁴ counts	
DLHR-L05G	0 to 5 inH2O	200 inH2O	300 inH2O	0.8 * 2 ²⁴ counts	
DLHR-L10G	0 to 10 inH2O	200 inH2O	300 inH2O	0.8 * 2 ²⁴ counts	
DLHR-L20G	0 to 20 inH2O	200 inH2O	500 inH2O	0.8 * 2 ²⁴ counts	
DLHR-L30G	0 to 30 inH2O	200 inH2O	500 inH2O	0.8 * 2 ²⁴ counts	
DLHR-L60G	0 to 60 inH2O	200 inH2O	800 inH2O	0.8 * 2 ²⁴ counts	

Pressure Sensor Maximum Ratings		Environmental Specifications	
Supply Voltage (Vs)	3.63 Vdc	Temperature Ranges	
Common Mode Pressure	10 psig	Compensated:	Commercial 0°C to 70°C Industrial -20°C to 85°C
Lead Temperature (soldering 2-4 sec.)	270 °C	Operating Storage	-25°C to 85 °C -40°C to 125 °C
		Humidity Limits (non condensing)	0 to 95% RH

Performance Characteristics for DLHR Series - Commercial and Industrial Temperature Range

ALL PARAMETERS ARE MEASURED AT 3.3V ±5% EXCITATION AND 25C UNLESS OTHERWISE SPECIFIED (NOTE 9). PRESSURE MEASUREMENTS ARE WITH POSITIVE PRESSURE APPLIED TO PORT B.

Parameter	Min	Typ	Max	Units	Notes
Output Span (FSS)					1
LxxD, FxxD	-	±0.4 * 2 ²⁴	-	Dec Count	
LxxG	-	0.8 * 2 ²⁴	-	Dec Count	
Offset Output @ Zero Diff. Pressure (OS_{dig})					-
LxxD, FxxD	-	0.5 * 2 ²⁴	-	Dec Count	
LxxG	-	0.1 * 2 ²⁴	-	Dec Count	
Total Error Band					2
F50D	-	0.35	1.5	%FSS	
L01x	-	0.25	1.0	%FSS	
L02x	-	0.25	0.75	%FSS	
L05x	-	0.20	0.75	%FSS	
L10x, L20x, L30x, L60x	-	0.15	0.75	%FSS	
Span Temperature Shift					3
F50x, L01x, L02x	-	±0.5	-	%FSS	
L05x, L10x, L20x, L30x, L60x	-	±0.2	-	%FSS	
Offset Temperature Shift					3
F50x, L01x, L02x	-	±0.5	-	%FSS	
L05x, L10x, L20x, L30x, L60x	-	±0.2	-	%FSS	
Offset Warm-up Shift					4
F50x, L01x, L02x	-	±0.25	-	%FSS	
L05x, L10x, L20x, L30x, L60x	-	±0.15	-	%FSS	
Offset Position Sensitivity (±1g)					-
F50x, L01x, L02x	-	±0.10	-	%FSS	
L05x, L10x, L20x, L30x, L60x	-	±0.05	-	%FSS	
Offset Long Term Drift (One Year)					-
F50x, L01x, L02x	-	±0.25	-	%FSS	
L05x, L10x, L20x, L30x, L60x	-	±0.15	-	%FSS	
Linearity, Hysteresis Error					6
F50D, LxxD	-	±0.25	-	%FSS	
LxxG	-	±0.10	-	%FSS	
Pressure Digital Resolution - No Missing Codes					-
16-bit Option	15.7	-	-	bit	
17-bit Option	16.7	-	-	bit	
18-bit Option	17.7	-	-	bit	
Temperature Output					-
Resolution	-	16	-	bit	
Overall Accuracy	-	2	-	°C	
Supply Current Requirement					5, 7, 8
During Active State (ICC _{Active})	-	2.0	2.6	mA	
During Idle State (ICC _{Idle})	-	100	250	nA	
Power On Delay					5
	-	-	2.5	ms	
Data Update Time (t_{DU})		(see table below)		ms	5, 7

Calibrated Resolution	Measurement Command										Units
	Single		Average2		Average4		Average8		Average16		
	Typ	Max	Typ	Max	Typ	Max	Typ	Max	Typ	Max	
16 bit option	2.80	3.1	5.40	6.0	10.60	11.7	21.00	23.2	41.80	46.0	ms
17 bit option	3.20	3.6	6.20	6.9	12.20	13.5	24.20	26.7	48.20	53.1	ms
18 bit option	3.70	4.1	7.20	8.0	14.20	15.7	28.20	31.1	56.20	61.9	ms

I2C / SPI Electrical Parameters for DLHR Series

Parameter	Symbol	Min	Typ	Max	Units	Notes
Input High Level	-	80.0	-	100	% of Vs	5
Input Low Level	-	0	-	20.0	% of Vs	5
Output Low Level	-	-	-	10.0	% of Vs	5
I2C Pull-up Resistor	-	1000	-	-	Ω	5
I2C Load Capacitance on SDA, @ 400 kHz	C _{SDA}	-	-	200	pF	5
I2C Input Capacitance (each pin)	C _{I2C_IN}	-	-	10.0	pF	5
I2C Address			41		decimal	

Pressure Output Transfer Function

$$Pressure(inH_2O) = 1.25 \times \left(\frac{P_{out_{dig}} - OS_{dig}}{2^{24}} \right) \times FSS(inH_2O)$$

Where:

$P_{out_{dig}}$ Is the sensor 24-bit digital output.

OS_{dig} Is the specified digital offset
 For Gage Operating Range sensors: $0.1 * 2^{24}$
 For Differential Operating Range sensors: $0.5 * 2^{24}$

$FSS(inH_2O)$ The sensor Full Scale Span in inches H₂O
 For Gage Operating Range sensors: Full Scale Pressure
 For Differential Operating Range sensors: 2 x Full Scale Pressure.

Temperature Output Transfer Function

$$Temperature(°C) = \left(\frac{T_{out_{dig}} * 125}{2^{24}} \right) - 40$$

Where:

$T_{out_{dig}}$ The sensor 24-bit digital temperature output.
 (Note that only the upper 16 bits are significant)

Specification Notes

- NOTE 1: THE SPAN IS THE ALGEBRAIC DIFFERENCE BETWEEN FULL SCALE DECIMAL COUNTS AND THE OFFSET DECIMAL COUNTS.
- NOTE 2: TOTAL ERROR BAND CONSISTS OF OFFSET AND SPAN TEMPERATURE AND CALIBRATION ERRORS, LINEARITY AND PRESSURE HYSTERESIS ERRORS, OFFSET WARM-UP SHIFT, OFFSET POSITION SENSITIVITY AND LONG TERM OFFSET DRIFT ERRORS.
- NOTE 3: SHIFT IS RELATIVE TO 25C.
- NOTE 4: SHIFT IS WITHIN THE FIRST HOUR OF EXCITATION APPLIED TO THE DEVICE.
- NOTE 5: PARAMETER IS CHARACTERIZED AND NOT 100% TESTED.
- NOTE 6: MEASURED AT ONE-HALF FULL SCALE RATED PRESSURE USING BEST STRAIGHT LINE CURVE FIT.
- NOTE 7: DATA UPDATE TIME IS EXCLUSIVE OF COMMUNICATIONS, FROM COMMAND RECEIVED TO END OF BUSY STATUS. THIS CAN BE OBSERVED AS EOC PIN LOW- STATE DURATION.
- NOTE 8: AVERAGE CURRENT CAN BE ESTIMATED AS : $ICC_{idle} + (t_{DU} / \text{READING INTERVAL}) * ICC_{Active}$. REFER TO FIGURE 2 FOR ACTIVE AND IDLE CONDITIONS OF THE SENSOR (THE ACTIVE STATE IS WHILE EOC PIN IS LOW).
- NOTE 9: THE SENSOR IS CALIBRATED WITH A 3.3V SUPPLY HOWEVER, AN INTERNAL REGULATOR ALLOWS A SUPPLY VOLTAGE OF 1.68V TO 3.6V TO BE USED WITHOUT AFFECTING THE OVERALL SPECIFICATIONS. THIS ALLOWS DIRECT OPERATION FROM A BATTERY SUPPLY.

Device Ordering Options

Output Resolution

Calibrated output resolution can be ordered to be 16, 17, or 18 bits. Higher resolution results in slower update times; see the Data Update Time in the Performance Characteristics table.

Coating

Parylene Coating: Parylene coating provides a moisture barrier and protection from some harsh media. Consult factory for applicability of Parylene for the target application and sensor type.

Operation Overview

The DLHR is a digital sensor with a signal path that includes a sensing element, a variable-bit analog to digital converter, a DSP and an IO block that supports either an I2C or SPI interface (see Figure 1 below). The sensor also includes an internal temperature reference and associated control logic to support the configured operating mode. Since there is a single ADC, there is also a multiplexer at the front end of the ADC that selects the signal source for the ADC.

Figure 1 - DLHR Essential Model

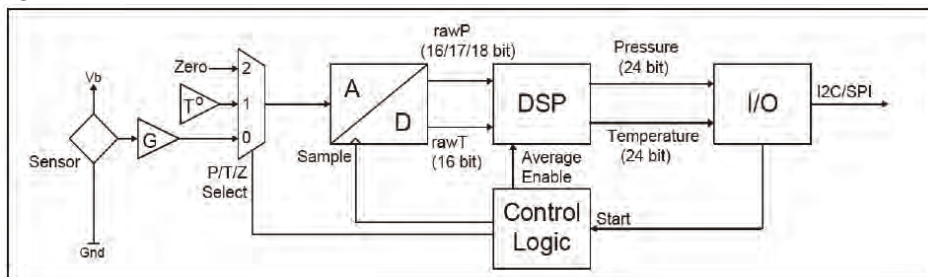

The ADC performs conversions on the raw sensor signal (P), the temperature reference (T) and a zero reference (Z) during the ADC measurement cycle.

The DSP receives the converted pressure and temperature information and applies a multi-order transfer function to compensate the pressure output. This transfer function includes compensation for span, offset, temperature effects on span, temperature effects on offset and second order temperature effects on both span and offset. There is also linearity compensation for gage devices and front to back linearity compensation for differential devices.

Sensor Commands: Five Measurement commands are supported, returning values of either a single pressure / temperature reading or an average of 2, 4, 8, or 16 readings. Each of these commands wakes the sensor from Idle state into Active state, and starts a measurement cycle. For the Start-Average commands, this cycle is repeated the appropriate number of times, while the Start-Single command performs a single iteration. When the DSP has completed calculations and the new values have been made available to the I/O block, the sensor returns to Idle state. The sensor remains in this low-power state until another Measurement command is received.

After completion of the measurement, the result may then be read using the Data Read command. The ADC and DSP remain in Idle state, and the I/O block returns the 7 bytes of status and measurement data. See Figure 2, following. At any time, the host may request current device status with the Status Read command. See Table 1 for a summary of all commands.

For optimum sensor performance, All Sensors recommends that Measurement commands be issued at a fixed interval by the host system. Irregular request intervals may increase overall noise on the output. *Furthermore, if reading intervals are much slower than the Device Update Time, using the Averaging commands is suggested to reduce offset shift. This shift is constant with respect to time interval, and may be removed by the application. For longer fixed reading intervals, this shift may be removed by the factory on special request.*

I/O Interface Configuration: The sensor automatically selects SPI or I2C serial interface, based on the following protocol: If the /SS input is set low by the host (as occurs during a SPI command transaction), the I/O interface will remain configured for SPI communications until power is removed. Otherwise, once a valid device address and command have been received over the I2C interface, the I/O interface will remain configured for I2C until power is removed.

NOTE: The four-pin (SIP) packages only support the I2C interface.

Operation Overview

Figure 2 - DLHR Communication Model

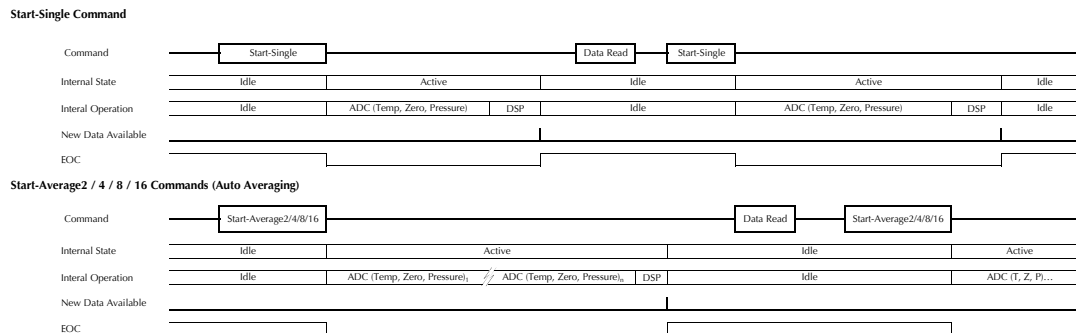

Digital Interface Command Formats

When requesting the start of a measurement, the command length for I2C is 1 byte, for SPI it is 3 bytes.

When requesting sensor status over I2C, the host simply performs a 1-byte read transfer.

When requesting sensor status over SPI, the host **MUST** send the Status Read command byte while reading 1 byte.

When reading sensor data over I2C, the host simply performs a 7-byte read transfer.

When reading sensor data over SPI, the host **MUST** send the 7-byte Data Read command while reading the data.

SENDING UNDOCUMENTED COMMANDS TO SENSOR WILL CORRUPT CALIBRATION AND IS NOT COVERED BY WARRANTY. See Table 1 below for Measurement Commands, Sensor Data read and Sensor Status read details.

Table 1 - DLHR Sensor Command Set

Measurement Commands				
Description	SPI (3 bytes)			I2C (1 byte)
Start-Single	0xAA	0x00	0x00	0xAA
Start-Average2	0xAC	0x00	0x00	0xAC
Start-Average4	0xAD	0x00	0x00	0xAD
Start-Average8	0xAE	0x00	0x00	0xAE
Start-Average16	0xAF	0x00	0x00	0xAF

Read Sensor Data	
I2C	Read of 7 bytes from device
SPI	Read of 7 bytes from device Host must send [0xF0], then 6 bytes of [0x00] on MOSI Sensor Returns 7 bytes on MISO

Read Sensor Status	
I2C	Read of 1 byte from device.
SPI	Read of 1 byte from device Host must send [0xF0] on MOSI Sensor Returns 1 byte on MISO

Digital Interface Data Format

For either type of digital interface, the format of data returned from the sensor is the same. The first byte consists of the Status Byte followed by a 24-bit unsigned pressure value and a 24-bit unsigned temperature value. Unused bits beyond the calibrated bit width are undefined, and may have any value. See the Pressure Output Transfer Function and Temperature Output Transfer Function definitions on page 3 for converting to pressure and temperature. Refer to Table 2 for the overall data format of the sensor. Table 3 shows the Status Byte definition. Note that a completed reading without error will return status 0x40.

Table 2 - Output Data Format

S[7:0]	P[23:16]	P[15:8]	P[7:0]	T[23:16]	T[15:8]	T[7:0]
Status Byte	Pressure Byte 3	Pressure Byte 1	Pressure Byte 0	Temperature Byte 3	Temperature Byte 1	Temperature Byte 0

Table 3- Status Byte Definition

Bit	Description
Bit 7 [MSB]	[Always = 0]
6	Power : [1 = Power On]
5	Busy: [1 = Processing Command, 0 = Ready]
4:3	Mode: [00 = Normal Operation]
2	Memory Error [1 = EEPROM Checksum Fail]
1	Sensor Configuration [always = 0]
Bit 0 [LSB]	ALU Error [1 = Error]

I2C Interface

I2C Command Sequence

The part enters Idle state after power-up, and waits for a command from the bus master. Any of the five Measurement commands may be sent, as shown in Table 1. Following receipt of one of these command bytes, the EOC pin is set to Low level, and the sensor Busy bit is set in the Status Byte. After completion of measurement and calculation in the Active state, compensated data is written to the output registers, the EOC pin is set high, and the processing core goes back to Idle state. The host processor can then perform the Data Read operation, which for I2C is simply a 7-byte Device Read.

If the EOC pin is not monitored, the host can poll the Status Byte by repeating the Status Read command, which for I2C is a one-byte Device Read. When the Busy bit in the Status byte is zero, this indicates that valid data is ready, and a full Data Read of all 7 bytes may be performed.

DO NOT SEND COMMANDS TO SENSOR OTHER THAN THOSE DEFINED IN TABLE 1.

I2C Interface (Cont'd)

I2C Bus Communications Overview

The I2C interface uses a set of signal sequences for communication. The following is a description of the supported sequences and their associated mnemonics. Refer to Figure 3 for the associated usage of the following signal sequences.

Bus not Busy (I): During idle periods both data line (SDA) and clock line (SCL) remain HIGH.

START condition (ST): A HIGH to LOW transition of SDA line while the clock (SCL) is HIGH is interpreted as START condition. START conditions are always set by the master. Each initial request for a pressure value has to begin with a START condition.

Slave address (An): The I²C-bus requires a unique address for each device. The DLH sensor has a preconfigured slave address (see specification table on Page 3). After setting a START condition the master sends the address byte containing the 7 bit sensor address followed by a data direction bit (R/W). A "0" indicates a transmission from master to slave (WRITE), a "1" indicates a device-to master request (READ).

Acknowledge (A or N): Data is transferred in units of 8 bits (1 byte) at a time, MSB first. Each data-receiving device, whether master or slave, is required to pull the data line LOW to acknowledge receipt of the data. The Master must generate an extra clock pulse for this purpose. If the receiver does not pull the data line down, a NACK condition exists, and the slave transmitter becomes inactive. The master determines whether to send the last command again or to set the STOP condition, ending the transfer.

DATA valid (Dn): State of data line represents valid data when, after a START condition, data line is stable for duration of HIGH period of clock signal. Data on line must be changed during LOW period of clock signal. There is one clock pulse per data bit.

STOP condition (P): LOW to HIGH transition of the SDA line while clock (SCL) is HIGH indicates a STOP condition. STOP conditions are always generated by the master.

Figure 3 - I2C Communication Diagram

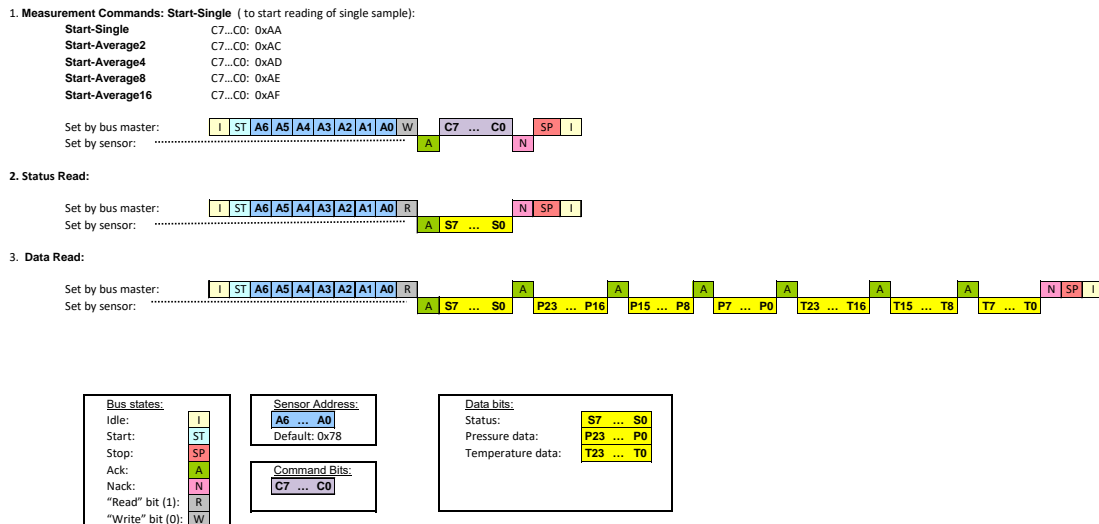

SPI Interface

SPI Command Sequence

As with the I2C interface configuration, the part enters Idle state after power-up, and waits for a command from the SPI master. To start a measurement cycle, one of the 3- byte Measurement Commands (see Table 1) must be issued by the master. The data returned by the sensor during this command request consists of the Status Byte followed by two undefined data bytes. On successful decode of the command, the EOC pin is set Low as the core goes into Active state for measurement and calculation. When complete, updated sensor data is written to the output registers, and the core goes back to the Idle state. The EOC pin is set to a High level at this point, and the Busy status bit is set to 0. At any point during the Active or Idle periods, the SPI master can request the Status Byte by sending a Status Read command (a single byte with value 0xF0). As with the I2C configuration, a Busy bit of value 0 in the Status Byte or a high level on the EOC pin indicates that a valid data set may be read from the sensor. The Data Read command must be sent from the SPI master (The first byte of value 0xF0 followed by 6 bytes of 0x00).

NOTE: Sending commands that are not defined in Table 1 will corrupt sensor operation.

SPI Bus Communications Overview

The sequence of bits and bus signals are shown in the following illustration (Figure 4). Refer to Figure 5 in the Interface Timing Diagram section for detailed timing data.

Figure 4 - SPI Communications Diagram

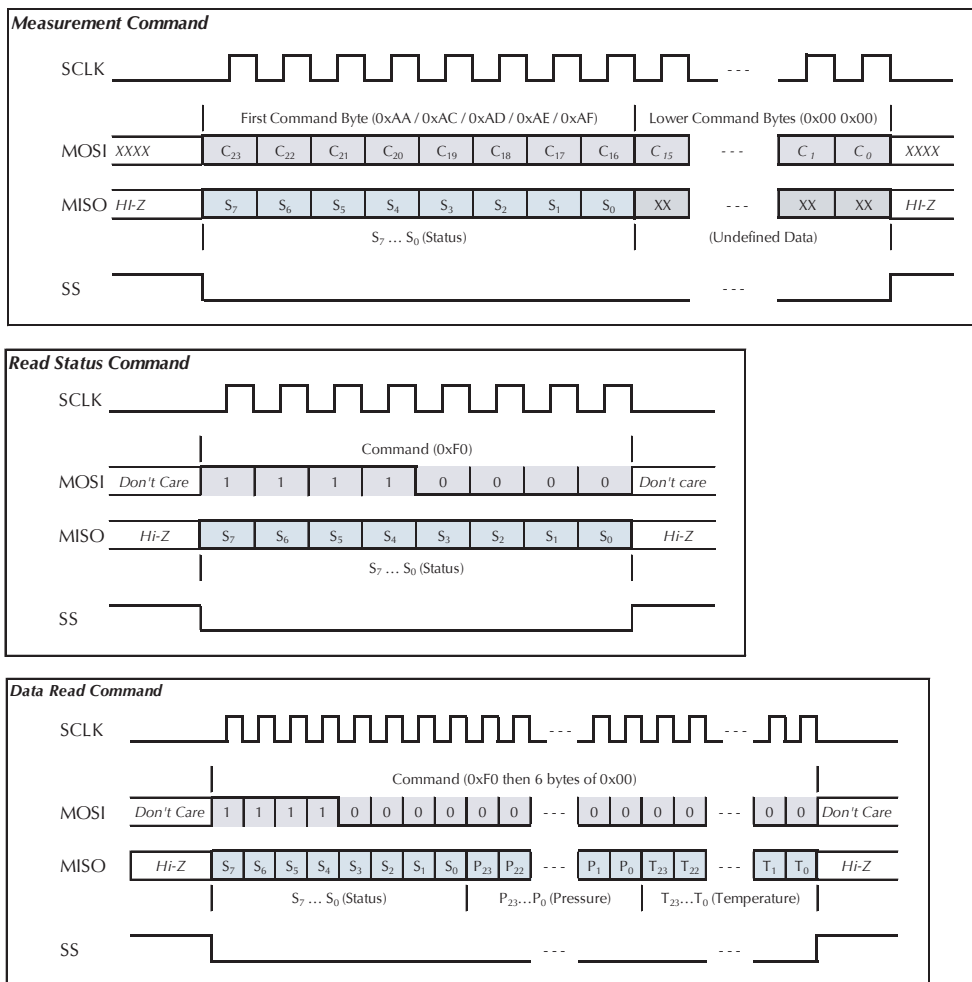

How to Order

Refer to Table 4 for configuring a standard base part number which includes the pressure range, package and temperature range. Table 5 shows the available configuring options. The option identifier is required to complete the device part number. Refer to Table 6 for the available device packages.

Example P/N with options: DLHR-L02D-E1NS-C-NAV6

Table 4 - How to configure a base part







ORDERING INFORMATION	SERIES	PRESSURE RANGE		PACKAGE						TEMPERATURE RANGE			
	ID	ID	Description	Base		Port Orientation		Lid Style		Lead Type		ID	Description
				ID	ID	Description	ID	Description	ID	Description	ID	Description	
	DLHR	F50D	±0.5 inH2O	E	1	Dual Port Same Side	N	Non-Barbed	S	SIP	C	Commercial	
		L01D	±1 inH2O		2	Dual Port Opposite Side	B	Barbed	D	DIP	I	Industrial	
		L02D	±2 inH2O						J	J-Lead SMT			
		L05D	±5 inH2O										
		L10D	±10 inH2O										
		L20D	±20 inH2O										
		L30D	±30 inH2O										
		L60D	±60 inH2O										
		L01G	0 to 1 inH2O										
		L02G	0 to 2 inH2O										
		L05G	0 to 5 inH2O										
		L10G	0 to 10 inH2O										
		L20G	0 to 20 inH2O										
		L30G	0 to 30 inH2O										
		L60G	0 to 60 inH2O										
Example	DLHR	L02D		E	1		N		S		C		

Table 5 - How to configure an option identifier

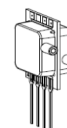
ORDERING INFORMATION	COATING		INTERFACE		SUPPLY VOLTAGE		RESOLUTION	
	ID	Description	ID	Description	ID	Description	ID	Description
	N	No Coating	A	Auto I2C/SPI	V	1.68V to 3.6V	6	16 Bit
P	Parylene Coating ⁽¹⁾					7	17 bit	
						8	18 bit	
Example	N		A		V		6	

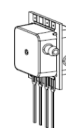
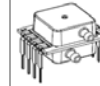
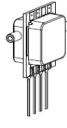
(1) Parylene coating not offered on J-Lead Configurations

Table 6 - Available E-Series Package Configurations

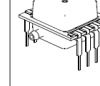
Port Orientation	Non-Barbed Lid Lead Style				Barbed Lid Lead Style			
	SIP ⁽¹⁾	DIP	J Lead SMT	Low Profile DIP	SIP ⁽¹⁾	DIP	J Lead SMT	Low Profile DIP
Dual Port Same Side	 E1NS	 E1ND	 E1NJ	N/A	 E1BS	 E1BD	N/A	N/A
Dual Port Opposite Side	 E2NS	 E2ND	 E2NJ	N/A	 E2BS	 E2BD	N/A	N/A
Single Port (Gage)	N/A	N/A	N/A	N/A	N/A	N/A	N/A	N/A

(1) SPI is not available in SIP packages

Package Drawings

E1NS Package

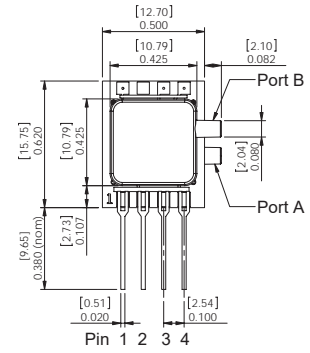
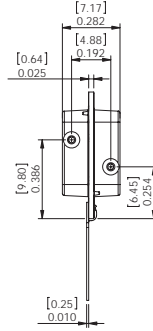
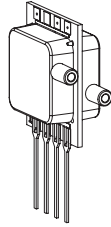

Pinout

- 1) Gnd
- 2) Vs
- 3) SDA
- 4) SCL

NOTES

- 1) Dimensions are in inches (mm)
- 2) For suggested pad layout, see drawing: PAD-01

E1BS Package

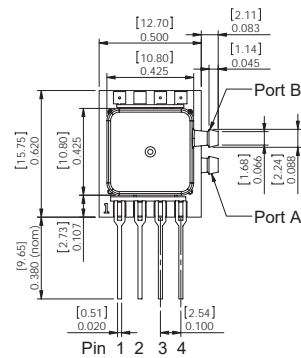
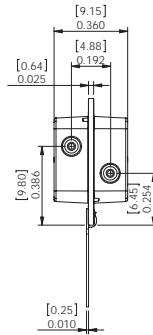
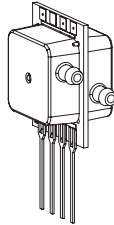

Pinout

- 1) Gnd
- 2) Vs
- 3) SDA
- 4) SCL

NOTES

- 1) Dimensions are in inches (mm)
- 2) For suggested pad layout, see drawing: PAD-01

Package Drawings (Cont'd)

E2NS Package

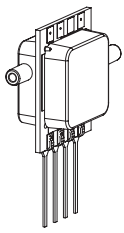

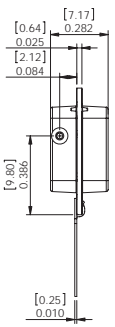

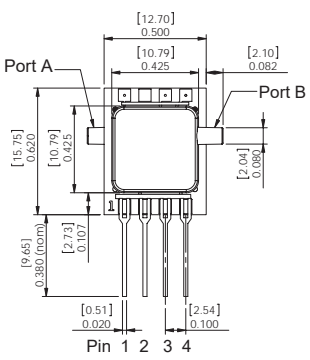

Pinout

- 1) Gnd
- 2) Vs
- 3) SDA
- 4) SCL

NOTES
 1) Dimensions are in inches [mm]
 2) For suggested pad layout, see drawing: PAD-01

E2BS Package

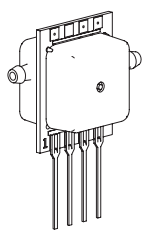

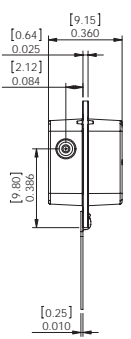

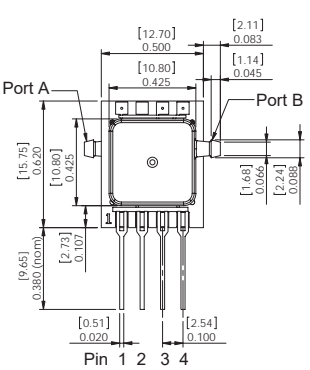

Pinout

- 1) Gnd
- 2) Vs
- 3) SDA
- 4) SCL

NOTES
 1) Dimensions are in inches [mm]
 2) For suggested pad layout, see drawing: PAD-01

Package Drawings (Cont'd)

E1ND Package

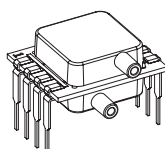
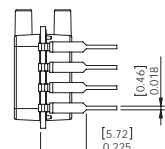
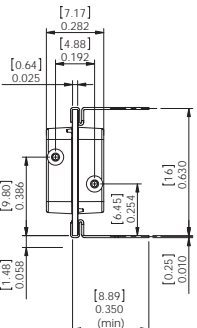
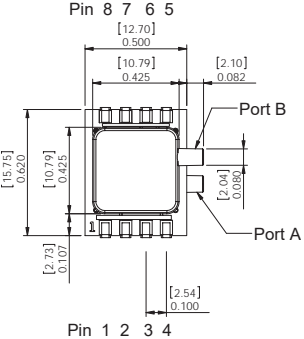





Pinout

- 1) Gnd
- 2) Vs
- 3) SDA/MOSI
- 4) SCL/SCLK
- 5) EOC
- 6) MISO
- 7) Not Connected
- 8) /SS

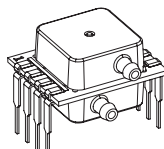
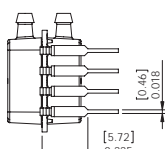
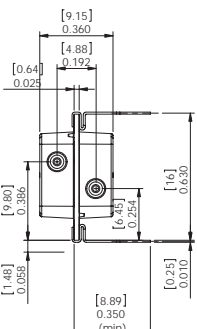
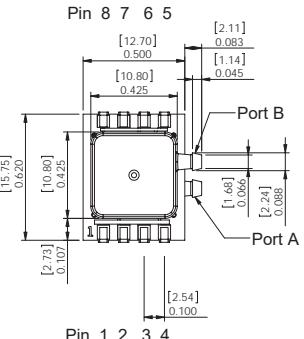
NOTES
 1) Dimensions are in inches [mm]
 2) For suggested pad layout, see drawing: PAD-03

E1BD Package

Pinout

- 1) Gnd
- 2) Vs
- 3) SDA/MOSI
- 4) SCL/SCLK
- 5) EOC
- 6) MISO
- 7) Not Connected
- 8) /SS

NOTES
 1) Dimensions are in inches [mm]
 2) For suggested pad layout, see drawing: PAD-03

Package Drawings (Cont'd)

E2ND Package

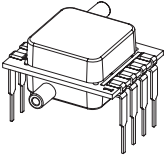
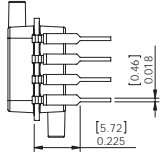
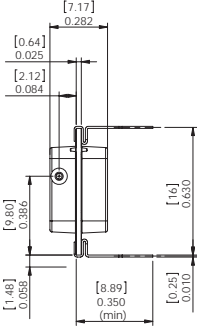
NOTES
 1) Dimensions are in inches [mm]
 2) For suggested pad layout, see drawing: PAD-03

Pinout

- 1) Gnd
- 2) Vs
- 3) SDA/MOSI
- 4) SCL/SCLK
- 5) EOC
- 6) MISO
- 7) Not Connected
- 8) /SS

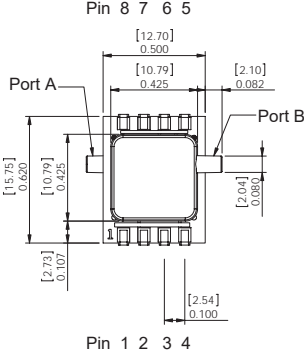

E2BD Package

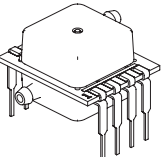
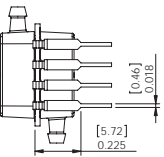
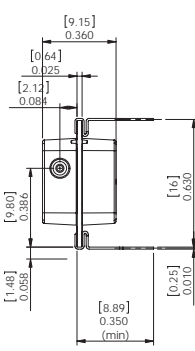
NOTES
 1) Dimensions are in inches [mm]
 2) For suggested pad layout, see drawing: PAD-03

Pinout

- 1) Gnd
- 2) Vs
- 3) SDA/MOSI
- 4) SCL/SCLK
- 5) EOC
- 6) MISO
- 7) Not Connected
- 8) /SS

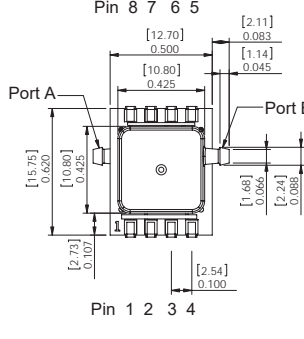

DLHR SERIES LOW VOLTAGE DIGITAL PRESSURE SENSORS

Page 14

www.allkensors.com® Signed Original On File

2-2

Package Drawings (Cont'd)

E1NJ Package

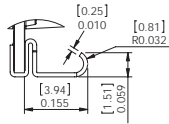
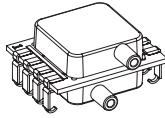

DETAIL A
SCALE 4 : 1

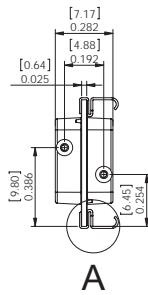

A

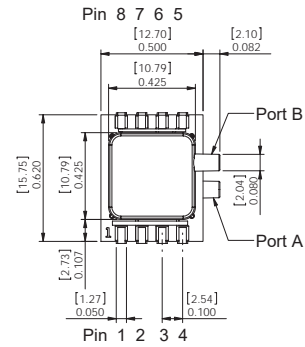

Pinout

- 1) Gnd
- 2) Vs
- 3) SDA/MOSI
- 4) SCL/SCLK
- 5) EOC
- 6) MISO
- 7) Not Connected
- 8) /SS

NOTES

- 1) Dimensions are in inches [mm]
- 2) For suggested pad layout, see drawing: PAD-10

E2NJ Package

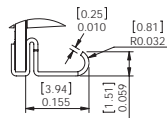
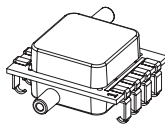

DETAIL A
SCALE 4 : 1

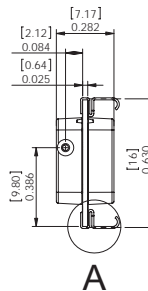

A

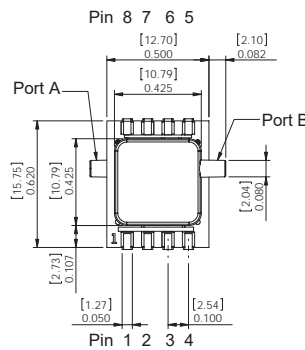

Pinout

- 1) Gnd
- 2) Vs
- 3) SDA/MOSI
- 4) SCL/SCLK
- 5) EOC
- 6) MISO
- 7) Not Connected
- 8) /SS

NOTES

- 1) Dimensions are in inches [mm]
- 2) For suggested pad layout, see drawing: PAD-10

Suggested Pad Layout

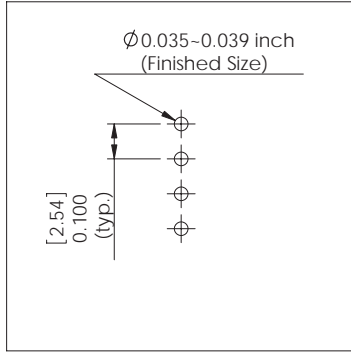

PAD-01

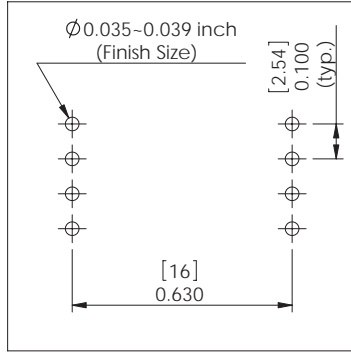

PAD-03

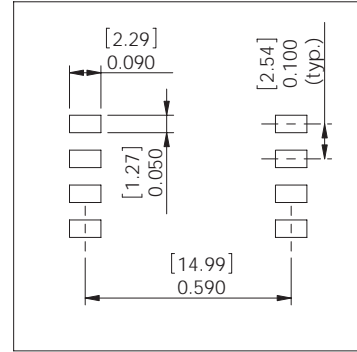

PAD-10

Product Labeling

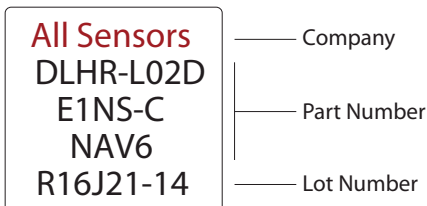

Example Device Label

All Sensors reserves the right to make changes to any products herein. All Sensors does not assume any liability arising out of the application or use of any product or circuit described herein, neither does it convey any license under its patent rights nor the rights of others.

DLV SERIES LOW VOLTAGE DIGITAL PRESSURE SENSORS

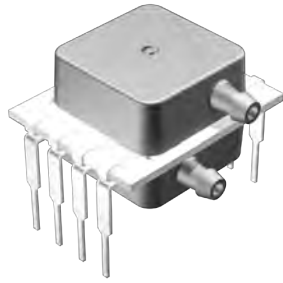

Features

- 5 to 60 psi and Barometric Pressure Ranges
- 3.3V or 5.0V Supply Voltage
- I2C or SPI Interface
- Better than 0.5% Accuracy Over Temperature Typical
- Die Sil-Gel Coating for Enhanced Media Protection

Applications

- Medical Breathing
- Environmental Controls
- HVAC
- Industrial Controls
- Portable/Hand-Held Equipment

General Description

The DLV Series Mini Digital Output Sensor is based on the already popular DLVR series pressure sensors. This series utilizes single chip technology and offers excellent performance over middle (5 psi to 60 psi) and barometric pressure ranges.

The supply voltage options ease integration of the sensors into a wide range of process control and measurement systems, allowing direct connection to either I2C or SPI serial communications channels. For battery-powered systems, the sensors can enter very low-power modes between readings to minimize load on the power supply.

These calibrated and compensated sensors provide accurate, stable output over a wide temperature range. This series is intended for use with non-corrosive, non-ionic working fluids such as air, dry gases and the like. A Sil-Gel die coating is added for enhanced media protection.

Standard Pressure Ranges

Device	Operating Range ^{A, B}		Proof Pressure		Burst Pressure		Nominal Span
	PSI	kPa	PSI	kPa	PSI	kPa	Counts
DLV-005D	± 5	35	20	140	40	275	±6,553
DLV-015D	± 15	100	40	415	120	830	±6,553
DLV-030D	± 30	200	120	830	200	1,380	±6,553
DLV-060D	± 60	400	200	1,380	200	1,380	±6,553
DLV-005G	0 to 5	35	20	140	40	275	13,107
DLV-015G	0 to 15	100	60	415	120	830	13,107
DLV-030G	0 to 30	200	120	830	200	1,380	13,107
DLV-060G	0 to 60	400	200	1,380	200	1,380	13,107
DLV-015A	0 to 15 psiA	100	60	415	120	830	13,107
DLV-030A	0 to 30 psiA	200	120	830	200	1,380	13,107
DLV-060A	0 to 60 psiA	400	200	1,380	200	1,380	13,107
DLV-611M	600 to 1100 mbarA	60 to 110 kPa	60	415	120	830	13,107

Note A: Operating range in kPa is expressed as an approximate value.

Note B: Products are calibrated to operating range expressed in psi (except DLV-611M, which is calibrated to range in millibars).

Pressure Sensor Maximum Ratings		Environmental Specifications	
Supply Voltage (Vs)	6 Vdc	Temperature Ranges	Compensated: Commercial 0°C to 70°C Industrial -20°C to 85°C
Common Mode Pressure	10 psig (70 kPa)		
Lead Temperature (soldering 2-4 sec.)	270 °C	Operating Storage	-25°C to 85°C -40°C to 125°C
		Humidity Limits (non condensing)	0 to 95% RH

Performance Characteristics for DLV Series - Commercial and Industrial Temperature Range

ALL PARAMETERS ARE MEASURED AT 3.3V ±5% OR 5.0V ±5% (DEPENDING ON SELECTED VOLTAGE OPTION) EXCITATION, AND AT 25°C, UNLESS OTHERWISE SPECIFIED. PRESSURE MEASUREMENTS ARE WITH POSITIVE PRESSURE APPLIED TO PORT B.

Parameter	Min	Typ	Max	Units	Notes
Output Span					1
xxxD	-	±6,553	-	Dec Count	
xxxG , xxxA	-	13,107	-	Dec Count	
Offset Output					
xxxD (at 0 PSIG)	-	8,192	-	Dec Count	
xxxG (at 0 PSIG) & xxxA (at 0 PSIA), 611M (at 600mBarA)	-	-	1,638	Dec Count	
Total Error Band					2
Span Temperature Shift	-	±0.1	-	%FSS	3
Offset Temperature Shift	-	±0.1	-	%FSS	3
Offset Warm-up Shift	-	±0.1	-	%FSS	4
Accuracy	-	±0.1	±0.25	%FSS	6
Response Delay					5, 10
Sleep - Wake Pressure	-	0.40	0.50	ms	
Sleep - Wake All	-	1.10	1.40	ms	
Power-On to First Reading Attempt	6.0 + 1 update period	-	-	ms	
Update Rate					5
Fast	-	0.40	1.0	ms	
Noise Reduced	-	1.30	3.1	ms	
Low Power	-	6.5	9.5	ms	
Start-up Time					5, 7
Offset Long Term Drift (One Year)	-	±0.1	-	%FSS	-
Digital Resolution					5
Output Resolution	-	14	-	bit	
No Missing Codes	12	13	-	bit	
Temperature Output					8
Resolution	-	11	-	bit	
Overall Accuracy	-	2	-	°C	
Current Requirement (3.3V Option)					5
Fast	-	2.5	3.2	mA	
Noise Reduced	-	2.5	3.1	mA	
Low Power	-	0.6	0.7	mA	
Sleep (Idle)	-	0.5	5.0	uA	
Current Requirement (5.0 Option)					5
Fast	-	3.5	4.5	mA	
Noise Reduced	-	3.6	4.4	mA	
Low Power	-	0.8	1.0	mA	
Sleep (Idle)	-	0.5	5.0	uA	

See the following page for performance characteristics table notes.

I2C / SPI Electrical Parameters for DLV Series

Parameter	Symbol	Min	Typ	Max	Units	Notes
Input High Level	-	80.0	-	100	% of Vs	5
Input Low Level	-	0	-	20.0	% of Vs	5
Output Low Level	-	-	-	10.0	% of Vs	5
I2C Pull-up Resistor	-	1000	-	-	Ω	5,9
I2C Load Capacitance on SDA, @ 400 kHz	C _{SDA}	-	-	200	pF	5
I2C Input Capacitance (each pin)	C _{I2C_IN}	-	-	10.0	pF	5

Specification Notes

NOTE 1: THE SPAN IS THE ALGEBRAIC DIFFERENCE BETWEEN FULL SCALE DECIMAL COUNTS AND THE OFFSET DECIMAL COUNTS.

PRESSURE OUTPUT TRANSFER FUNCTION

$$Pressure(PSI) = 1.25 \times \left(\frac{P_{out_{dig}} - OS_{dig}}{2^{14}} \right) \times FSS(PSI)$$

Where,

$P_{out_{dig}}$ Is the sensor 14 bit digital output.
 OS_{dig} Is the specified digital offset (gage/absolute, 611M = 1,638 and differential = 8,192)
 $FSS(PSI)$ Is the sensor Full Scale Span (gage = Full Scale Pressure, differential = 2 x Full Scale Pressure) in psi.
 (For 611M, = 500 mBar).

For DLV-611M, replace 'psi' units with 'mbar'.

NOTE 2: TOTAL ERROR BAND CONSISTS OF OFFSET AND SPAN TEMPERATURE AND CALIBRATION ERRORS, LINEARITY AND PRESSURE HYSTERESIS ERRORS, OFFSET WARM-UP SHIFT AND LONG TERM OFFSET DRIFT ERRORS.

NOTE 3: SHIFT IS RELATIVE TO 25C.

NOTE 4: SHIFT IS WITHIN THE FIRST HOUR OF EXCITATION APPLIED TO THE DEVICE.

NOTE 5: PARAMETER IS CHARACTERIZED AND NOT 100% TESTED.

NOTE 6: INCLUDES PRESSURE HYSTERESIS, REPEATABILITY AND BEST-FIT STRAIGHT LINE LINEARITY, EVALUATED AT 25C.

NOTE 7: POWER-ON TIME IS TIME FROM POWER BEING APPLIED TO FIRST AVAILABLE PART COMMUNICATIONS.

NOTE 8: Temperature Output Transfer Function:

$$Temperature (^{\circ}C) = T_{out_{dig}} \times \left(\frac{200}{2^{11} - 1} \right) - 50$$

NOTE 9: A PULL-UP RESISTOR IS REQUIRED FOR CORRECT I2C USAGE. THE MINIMUM VALUE INDICATED IS FOR 5.0V OR 3.3V OPERATION.

NOTE 10: FOLLOWING SENSOR POWER-UP, THE APPLICATION MUST WAIT AT LEAST THE INDICATED TIME BEFORE ATTEMPTING TO COMMUNICATE WITH THE SENSOR.

Figure 1 - Equivalent Circuit

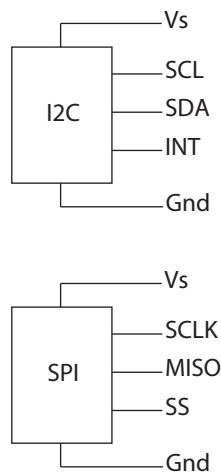

Device Options

The following is a list of factory programmable options. Consult the factory to learn more about the options.

Interface

I2C and SPI interfaces are available. NOTE: SPI interface is only available with eight (8) lead packages.

Supply Voltage

Devices are characterized at either 3.3V or 5.0V depending on the options selected. It is suggested to select the option that most closely matches the application supply voltage for best possible performance.

Speed/Power

There are four options of Speed/Power. These are Fast(F), Noise Reduced(N), Low Power(L) and Sleep mode(S).

Fast Mode(F) Is the fastest operating mode where the device operates with continuous sampling at the fastest internal speed.

Noise Reduced(N): Also operates with continuous samples however the ADC is set for over sampling for noise reduction. The conversion times are resultantly longer than the Fast(F) mode however, there is approximately 1/2 bit reduction in noise.

Low Power(L): Is similar to the Fast(F) mode with exception that the device uses an internal timer to delay between pressure conversions. The internal timer time-out triggers the next conversion cycle. The update rate is commensurately lower for this mode as a result.

Sleep(S): Is similar to the Low Power(L) mode however the trigger to initiate a sample comes from the user instead of an internal timer. This is ideal for very low update rate applications that require low power usage. It is also ideal for synchronizing the data conversions with the host microprocessor.

Coating

Parylene Coating: Parylene coating provides a moisture barrier and protection from some harsh media. The DLV Series includes a Sil-Gel die coating for enhanced media protection. Parylene is available for all parts. Consult the factory for applicability of the parylene option for the for the target application.

Operation Overview

The DLV is a digital sensor with a signal path that includes a sensing element, a 14 bit analog to digital converter, a DSP and an IO block that supports either an I2C or SPI interface (see Figure 1 below). The sensor also includes an internal temperature reference and associated control logic to support the configured operating mode. The sensing element is powered down while not being sampled to conserve power. Since there is a single ADC, there is also a multiplexer at the front end of the ADC that selects the signal source for the ADC.

Figure 2 - DLV Essential Model

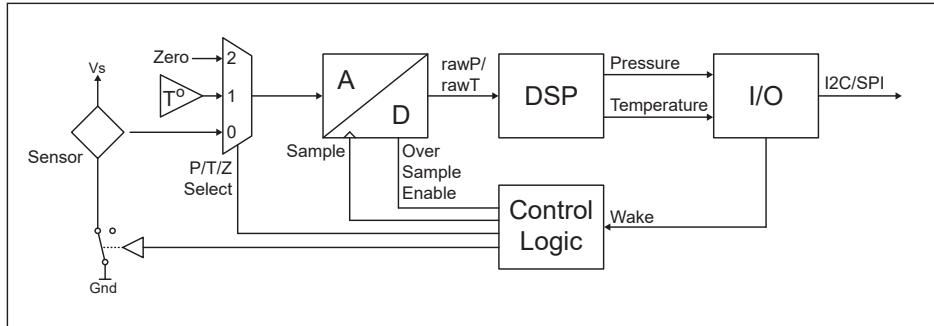

The ADC performs conversions on the raw sensor signal (P), the temperature reference (T) and a zero reference (Z) during an ADC zero cycle. It also has an oversampling mode for a noise reduced output. A conversion cycle that is measuring pressure is called a Normal cycle. A cycle where either a temperature measurement or zeroing is being performed is called a Special cycle.

The DSP receives the converted pressure and temperature information and applies a multi-order transfer function to compensate the pressure output. This transfer function includes compensation for span, offset, temperature effects of span, temperature effects on offset and second order temperature effects on both span and offset. There is also linearity compensation for all devices.

There are two effective operating modes of the sensor 1) Free Running and 2) Triggered. The control logic performs the synchronization of the internal functions according the factory programmed Power/Speed option (see Table 1). The Control Logic also determines the Delay between ADC samples, the regularity of the Special cycles and whether or not the ADC performs the Over Sampling. Refer to Figure 2 for the communication model associated with the operating modes listed below.

Free Running Mode: In the free running mode, conversion cycles are initiated internally at regular intervals. There are three options available that operate in the Free Running mode (F, N and L). Two of these (F and N) run continuously while the third option (L) has an approximate 6 ms delay between conversion cycles. All three options have Special cycles inserted at regular intervals to accomplish the ADC zeroing and temperature measurements. Two of the options utilize oversampling. Refer to Table 1 for specific option controls.

Triggered Mode: In the Triggered Mode, a conversion cycle is initiated by the user (or host uP). There are two available methods to wake the sensor from sleep mode. The first method (Wake All) is to wake the sensor and perform all three measurement cycles (Z, T and P). This provides completely fresh data from the sensor. The second method (Wake P) is to wake the sensor from sleep and only perform the pressure measurement (P). When using this second method, it is up to the user to interleave Wake All commands at regular intervals to ensure there is sufficiently up to date temperature information. Also, the Wake Pressure method is only available from the I2C interface (not available using a SPI interface).

Operation Overview (Cont'd)

Table 1 - DLV Control Logic Detail

Control Logic							
Power/Speed Option	Power/Speed Description	Operating Mode	Over Sample	Delay Between Samples	Normal ADC Cycles	Special ADC Cycles	Special ADC Cycle Interval
F	Fast	Free Running	No	No	1 (P)	1 (Z or T)	255
N	Noise Reduced		Yes	No	1 (P)	1 (Z or T)	255
L	Low Power		Yes	Yes	1 (P)	1 (Z or T)	31
S	Sleep ⁽¹⁾ (Wake Pressure)	Triggered	No	User Defined	1 (P)	n/a	Never
	Sleep (Wake All)		No	User Defined	1 (P)	2 (Z + T)	Always

Note 1) Wake from sleep with pressure only reading is not available with SPI interface (I2C only).

Figure 3 - DLV Communication Model

Free Running Mode [(F)ast, (N)oise Reduced and (L)ow Power Option]

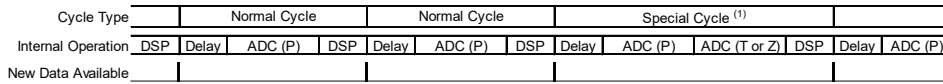

Note 1: See Table 1 for frequency of Special Cycles

Triggered Mode - Wake All [(S)leep Option]

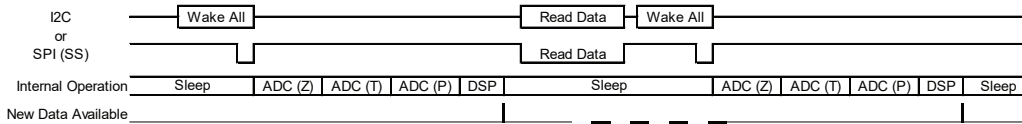

Triggered Mode - Wake Pressure [(S)leep Option]

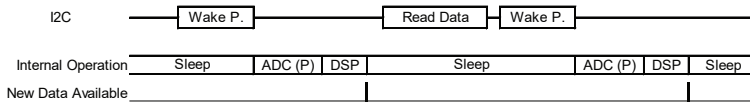

Digital Interface Data Format

For either type of digital interface, the format of data returned from the sensor is the same. The first 16 bits consist of the 2 Status bits followed by the 14-bit the pressure value. The third byte provides the 8 most significant bits of the measured temperature; the fourth byte provides the 3 least significant bits of temperature, followed by 5 bits of undefined filler data. With either interface, the host may terminate the transfer after receiving the first two bytes of data from the sensor, or following the third byte (if just the most-significant 8 bits of temperature are needed). Refer to Table 2 for the overall data format of the sensor. Table 3 shows the Status Bit definition.

Table 2 - Output Data Format

D[31:30]	D[29:24]	D[23:16]	D[15:8]	D[7:5]	D[4:0]
S[1:0]	P[13:8]	P[7:0]	T[10:3]	T[2:0]	X[4:0]
Status	Pressure MSB	Pressure LSB	Temperature MSB	Temperature LSB	Filler bits (Undefined)

Bit Definitions:

Status (S): Normal/command / busy / diagnostic

Pressure (P): Digital pressure reading

Temperature (T): Compensated temperature reading

Table 3- Status Bit Definitions

[00]	[01]	[10]	[11]
Current Data, no errors.	(Reserved)	Stale Data: Not updated since last read.	Error Condition: electrical fault or configuration invalid.

I2C Interface

I2C Communications Overview

The I2C interface uses a set of signal sequences for communication. The following is a description of the supported sequences and their associated mnemonics. Refer to Figure 3 for the associated usage of the following signal sequences.

Bus not Busy (I): During idle periods both data line (SDA) and clock line (SCL) remain HIGH.

START condition (ST): A HIGH to LOW transition of SDA line while the clock (SCL) is HIGH is interpreted as START condition. START conditions are always set by the master. Each initial request for a pressure value has to begin with a START condition.

Slave address (An): The I²C-bus requires a unique address for each device. The DLV sensor has a preconfigured slave address (0x28). After setting a START condition the master sends the address byte containing the 7 bit sensor address followed by a data direction bit (R/W). A "0" indicates a transmission from master to slave (WRITE), a "1" indicates a data request (READ).

Acknowledge (A or N): Data is transferred in units of 8 bits (1 byte) at a time, MSB first. Each data-receiving device, whether master or slave, is required to pull the data line LOW to acknowledge receipt of the data. The Master must generate an extra clock pulse for this purpose. If the receiver does not pull the data line down, a NACK condition exists, and the slave transmitter becomes inactive. The master determines whether to send the last command again or to set the STOP condition, ending the transfer.

DATA valid (Dn): State of data line represents valid data when, after a START condition, data line is stable for duration of HIGH period of clock signal. Data on line must be changed during LOW period of clock signal. There is one clock pulse per data bit.

DATA operation: The sensor starts to send 4 data bytes containing the current pressure and temperature values. The transmission may be halted by the host after any of the bytes by responding with a NACK.

STOP condition (P): LOW to HIGH transition of the SDA line while clock (SCL) is HIGH indicates a STOP condition. STOP conditions are always generated by the master.

I2C Communications Overview (Cont'd)

Figure 4 - I2C Communication Diagram

I2C Communications Diagram

1. Start All (to wake sensor from Sleep mode, Zero ADC, read Temperature and read Pressure)

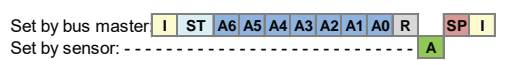

2. Start Pressure (to wake sensor from Sleep mode and read Pressure only)

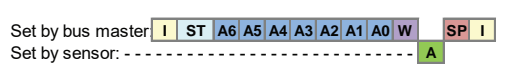

3. Read Data (with examples of reading pressure, pressure plus 8 bits of temperature and pressure plus 11 bits of temperature)

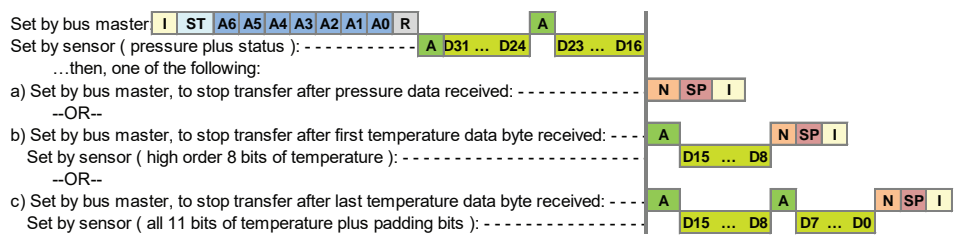

Bus states	
Idle:	I
Start:	ST
Stop:	SP
Ack:	A
Nack:	N
"Read" bit (1):	R
"Write" bit (0):	W

Sensor Address	
A6 ... A0	
Default:	0x28

Data format	
Status:	D31 D30
Pressure data:	D29 ... D16
Temperature data:	D15 ... D5
(padding bits:)	D4 ... D0

Figure 3 illustrates the sequence of signals set by both the host and the sensor for each command. Note that for the DataRead command, the host has the option of responding to the second or third bytes of data with a NACK instead of ACK. This terminates the data transmission after the pressure data, or after the pressure data and upper byte of temperature, have been transmitted. See Figure 6 for the I2C timing details.

I2C Command Sequence

Depending on whether the Fast, Noise Reduced, Low-Power, or Sleep options have been selected, the command sequence differs slightly. See Figure 3 for details of the three I2C commands.

Fast, Noise Reduced or Low-power Configuration

The part enters Free Running mode (see table 1) after power-up: it performs an initial complete measurement, writes the calculated data to the output registers, sets the INT pin high, then goes to sleep. After a delay determined by the update rate option, the part will wake up, perform measurements, update the output registers, then go back to sleep. DataRead is the only command recognized in this Free Running Mode. If the INT pin is ignored, the host processor can repeat the DataRead command until the Status bits indicate an updated reading. Note: The INT pin is not available on the SIP version packages (ExBS versions).

Sleep Configuration

The part enters Triggered mode (see table 1) after power-up, and waits for a command from the bus master. If the StartAll command is received, the temperature, ADC zero, and pressure readings are all measured, and correction calculations are performed. When valid data is written to the output registers, the INT pin is set high, and the processing core goes back to sleep. The host processor then sends the DataRead command to shift out the updated values. If the INT pin is not monitored, the host can poll the output registers by repeating the DataRead command until the Status bits indicate that the values have been updated (see Tables 2 and 3). The response time depends on configuration options (refer to Table 1 and Performance Characteristics).

Depending on the application, pressure measurements may be performed by sending the StartPressure command, which only measures the pressure value and uses previously measured temperature data in calculating the compensated output value. This presents the result faster (in about 1/3 the delay time) than the StartAll command. This can be a useful method to synchronize the sensor with the host controller as well as attaining the fastest overall response time without Special cycles occurring at unwanted times. The system designer should determine the interval required for sending StartAll commands, necessary to refresh the temperature and zero point data, in order to maintain accurate output values.

I2C Exceptions

1. Sending a Start condition, then a Stop condition, without any transitions on the CLK line, creates a communication error for the next communication, even if the next start condition is correct and the clock pulse is applied. A second Start condition must be set, which clears the error and allows communication to proceed.
2. The Restart condition—a falling SDA edge during data transmission when the CLK clock line is still high—creates the same stall/deadlock. In the following data request, an additional Start condition must be sent for correct communication.
3. A falling SDA edge is not allowed between the start condition and the first rising SCL edge. If using an I2C address with the first bit 0, SDA must be held low from the start condition through the first bit.

SPI Interface

SPI Command Sequence

DLV sensors using the SPI interface option provide 3 signals for communication: SCLK, SS (Slave Select), and MISO. This read-only signaling uses a hardware protocol to control the sensor, differing slightly with the speed/power option selected as described below:

Fast(F), Noise Reduced(N) and Low-Power(L) Configurations: After power-up, the part enters Free Running mode and begins its periodic conversion cycle, at the interval determined by the programmed Power/Speed option. This is the simplest configuration. The only bus interaction with the host is the SPI DataRead operations. Polling the sensor at a rate slower than the internal update rate will minimize bus activity and ensure that new values are presented with each transfer. Note that the Status bits should still be checked to verify updated data and the absence of error conditions.

Sleep(S) Configuration: As with the I2C option, the part enters Triggered mode after power-up, and waits for a command from the bus master. To wake the part and start a measurement cycle, the SS pin must be driven low by the host for at least 8usec, then driven high. This can be done by shifting a dummy byte of 8 bits from the sensor. This bus activity can be considered the SPI StartAll command, where the rising edge of SS is the required input to start conversion. Updated conversion data is written to the output registers after a period dependent on configuration options (see Performance Characteristics). After this update of the registers, the core goes to an inactive (sleep) state. The DataRead command simply consists of shifting out 2, 3, or 4 bytes of data from the sensor. The host can check the Status bits of the output to verify that new data has been provided. The part remains inactive following this read operation, and another StartAll operation is needed to wake the part when the next conversion is to be performed.

SPI Bit Pattern

The sequence of bits and bus signals are shown in the following illustration (Figure 4). Refer to Figure 5 in the Interface Timing Diagram section for detailed timing data. As previously described, the incoming data may be terminated by raising SS after 2, 3, or 4 bytes have been received as illustrated below.

Figure 5 - SPI Bit Pattern

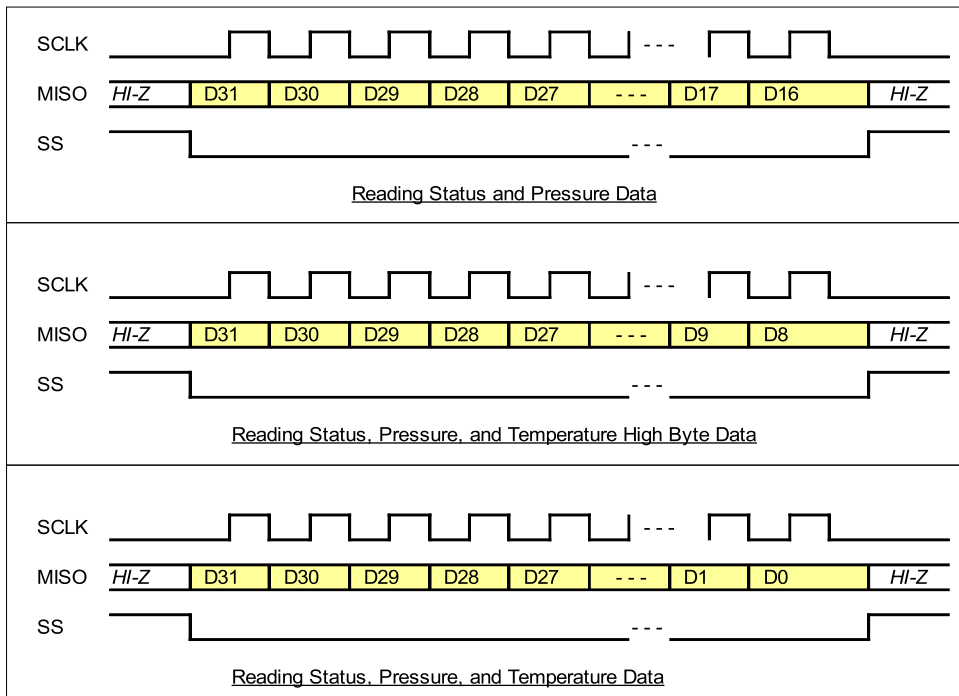

Interface Timing Diagrams

Figure 6 - SPI Timing Diagram

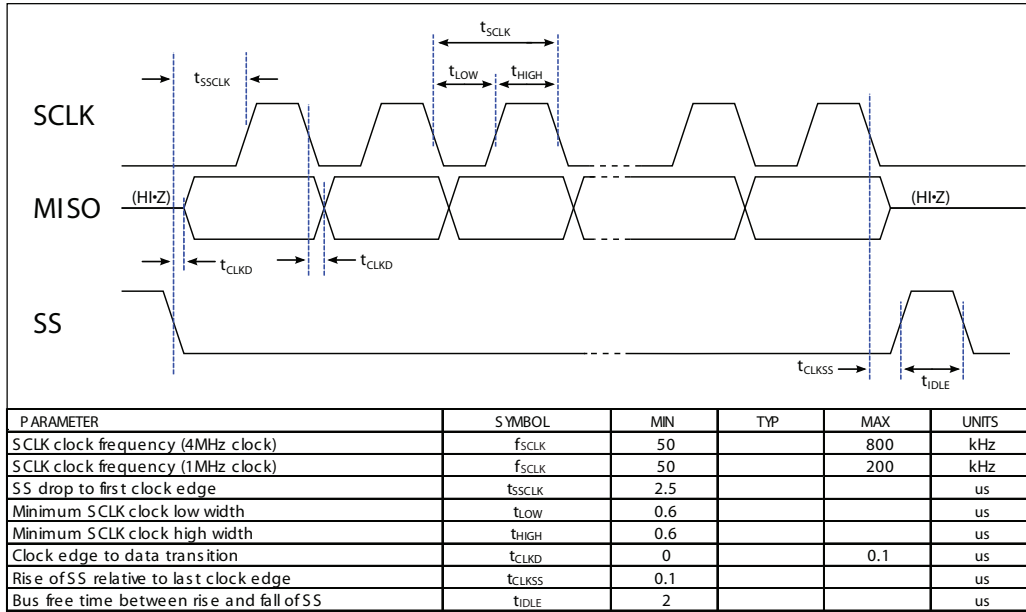
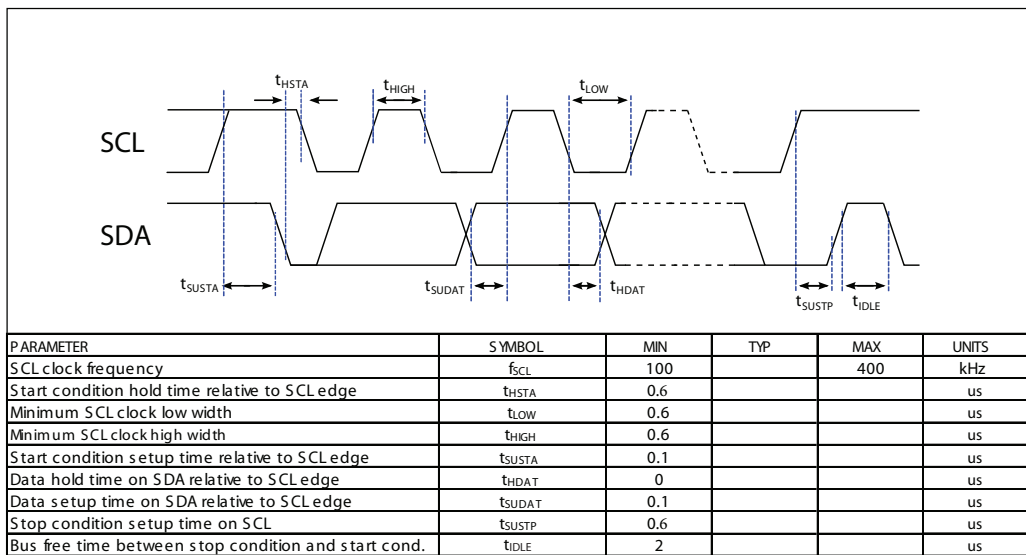

Figure 7 - I2C Timing Diagram



How to Order

Refer to Table 4 for configuring a standard base part number which includes the pressure range, package and temperature range. Table 5 shows the available configuring options. The option identifier is required to complete the device part number. Refer to Table 6 for the available package options.

Example P/N with options: DLV-005G-E1BD-C-NI3F

Table 4 - How to Configure a Base Part Number

ORDERING INFORMATION	SERIES		PRESSURE RANGE		PACKAGE						TEMPERATURE RANGE			
	ID	Description	ID	Description	Base		Port Orientation		Lid Style		Lead Type		ID	Description
					ID	Description	ID	Description	ID	Description	ID	Description		
	DLV		005D	±5 PSI	E	1	Dual Port Same Side	B	Barbed	S	SIP	C	Commercial	
			015D	±15 PSI		2	Dual Port Opposite Side			D	DIP	I	Industrial	
			030D	±30 PSI										
			060D	±60 PSI										
			005G	0 to 5 PSI										
			015G	0 to 15 PSI										
			030G	0 to 30 PSI										
			060G	0 to 60 PSI										
			015A	0 to 15 PSIA										
			030A	0 to 30 PSIA										
			060A	0 to 60 PSIA										
			611M	600 to 1100 mBarA										
Example	DLV	-	005G		-	E	1		B		S		C	

Table 5 - How to Configure an Option Identifier

ORDERING INFORMATION	COATING		INTERFACE		SUPPLY VOLTAGE		SPEED/POWER	
	ID	Description	ID	Description	ID	Description	ID	Description
	N	No Coating	I	I2C	3	3.3V	F	Fast
	P	Parylene Coating	S	SPI	5	5.0V	N	Noise reduced
							L	Low Power
							S	Sleep Mode
Example	N		I		3		F	

TABLE 6: Available E-Series Package Configurations

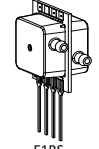
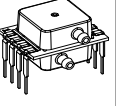
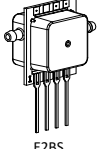
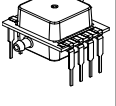
Port Orientation	Non-Barbed Lid				Barbed Lid			
	Lead Style				Lead Style			
	SIP	DIP	J Lead SMT	Low Profile DIP	SIP	DIP	J Lead SMT	Low Profile DIP
Dual Port Same Side	N/A	N/A	N/A	N/A			N/A	N/A
					E18S	E1BD		
Dual Port Opposite Side	N/A	N/A	N/A	N/A			N/A	N/A
					E28S	E2BD		
Single Port (Gage)	N/A	N/A	N/A	N/A	N/A	N/A	N/A	N/A

Package Drawings

E1BS Package

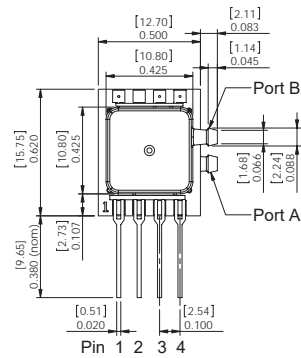
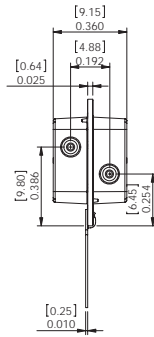
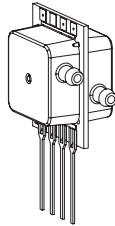

Pinout

- 1) Gnd
- 2) Vs
- 3) SDA
- 4) SCL

NOTES

- 1) Dimensions are in inches [mm]
- 2) For suggested pad layout, see drawing: PAD-01

E2BS Package

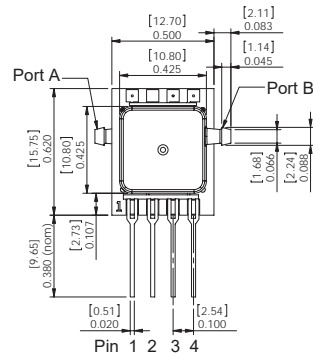
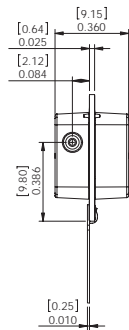
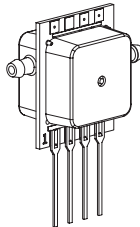

Pinout

- 1) Gnd
- 2) Vs
- 3) SDA
- 4) SCL

NOTES

- 1) Dimensions are in inches [mm]
- 2) For suggested pad layout, see drawing: PAD-01

Package Drawings (Cont'd)

E1BD Package

Pinout

- 1) Gnd
- 2) Vs
- 3) SDA/MISO
- 4) SCL/SCLK
- 5) INT/SS
- 6) Do Not Connect
- 7) Do Not Connect
- 8) Do Not Connect

NOTES

- 1) Dimensions are in inches [mm]
- 2) For suggested pad layout, see drawing: PAD-03

E2BD Package

Pinout

- 1) Gnd
- 2) Vs
- 3) SDA/MISO
- 4) SCL/SCLK
- 5) INT/SS
- 6) Do Not Connect
- 7) Do Not Connect
- 8) Do Not Connect

NOTES

- 1) Dimensions are in inches [mm]
- 2) For suggested pad layout, see drawing: PAD-03

DLVR SERIES LOW VOLTAGE DIGITAL PRESSURE SENSORS

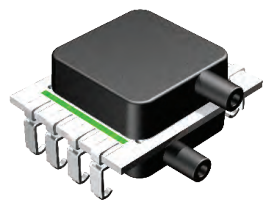

Features

- 0.5 to 60 inH2O Pressure Ranges
- 3.3V Supply Voltage Standard / 5V Option
- I2C Standard Interface / SPI Interface Option
- Better than 1.0% Accuracy Over Temperature Typical

Applications

- Medical Breathing
- Environmental Controls
- HVAC
- Industrial Controls
- Portable/Hand-Held Equipment

General Description

The DLVR Series Mini Digital Output Sensor is based on All Sensors' CoBeam²™ Technology. This reduces package stress susceptibility, resulting in improved overall long term stability. The technology also vastly improves position sensitivity compared to single die devices.

The supply voltage options ease integration of the sensors into a wide range of process control and measurement systems, allowing direct connection to serial communications channels. For battery-powered systems, the sensors can enter very low-power modes between readings to minimize load on the power supply.

These calibrated and compensated sensors provide accurate, stable output over a wide temperature range. This series is intended for use with non-corrosive, non-ionic working fluids such as air, dry gases and the like. A protective parylene coating is optionally available for moisture/harsh media protection.

Standard Pressure Ranges					Equivalent Circuit
Device	Operating Range	Proof Pressure	Burst Pressure	Nominal Span	
DLVR-F50D	±0.5 inH2O	100 inH2O	300 inH2O	±6,553 counts	
DLVR-L01D	±1 inH2O	100 inH2O	300 inH2O	±6,553 counts	
DLVR-L02D	±2 inH2O	100 inH2O	300 inH2O	±6,553 counts	
DLVR-L05D	±5 inH2O	200 inH2O	300 inH2O	±6,553 counts	
DLVR-L10D	±10 inH2O	200 inH2O	300 inH2O	±6,553 counts	
DLVR-L20D	±20 inH2O	200 inH2O	500 inH2O	±6,553 counts	
DLVR-L30D	±30 inH2O	200 inH2O	500 inH2O	±6,553 counts	
DLVR-L60D	±60 inH2O	200 inH2O	800 inH2O	±6,553 counts	
DLVR-L01G	0 to 1 inH2O	100 inH2O	300 inH2O	13,107 counts	
DLVR-L02G	0 to 2 inH2O	100 inH2O	300 inH2O	13,107 counts	
DLVR-L05G	0 to 5 inH2O	200 inH2O	300 inH2O	13,107 counts	
DLVR-L10G	0 to 10 inH2O	200 inH2O	300 inH2O	13,107 counts	
DLVR-L20G	0 to 20 inH2O	200 inH2O	500 inH2O	13,107 counts	
DLVR-L30G	0 to 30 inH2O	200 inH2O	500 inH2O	13,107 counts	
DLVR-L60G	0 to 60 inH2O	200 inH2O	800 inH2O	13,107 counts	

Pressure Sensor Maximum Ratings		Environmental Specifications	
Supply Voltage (Vs)	6 Vdc	Temperature Ranges	
Common Mode Pressure	10 psig	Compensated:	Commercial 0°C to 70°C Industrial -20°C to 85°C
Lead Temperature (soldering 2-4 sec.)	270 °C	Operating Storage	-25°C to 85 °C -40°C to 125 °C
		Humidity Limits (non condensing)	0 to 95% RH

Performance Characteristics for DLVR Series - Commercial and Industrial Temperature Range

ALL PARAMETERS ARE MEASURED AT 3.3V ±5% OR 5.0V ±5% (DEPENDING ON SELECTED VOLTAGE OPTION) EXCITATION AND 25°C UNLESS OTHERWISE SPECIFIED. PRESSURE MEASUREMENTS ARE WITH POSITIVE PRESSURE APPLIED TO PORT B.

Parameter	Min	Typ	Max	Units	Notes
Output Span					1
LxxD, FxxD	-	±6,553	-	Dec count	
LxxG	-	13,107	-	Dec count	
Offset Output @ Zero Diff. Pressure					-
LxxD, FxxD	-	8,192	-	Dec count	
LxxG	-	1,638	-	Dec count	
Total Error Band					2
F50D	-	±0.60	±1.5	%Span	
L01x, L02x	-	±0.50	±1.0	%Span	
L05x, L10x, L20x, L30x, L60x	-	±0.30	±0.75	%Span	
Span Temperature Shift					3
F50D, L01x, L02x	-	±0.5	-	%FSS	
L05x, L10x, L20x, L30x, L60x	-	±0.2	-	%FSS	
Offset Temperature Shift					3
F50D, L01x, L02x	-	±0.5	-	%FSS	
L05x, L10x, L20x, L30x, L60x	-	±0.2	-	%FSS	
Offset Warm-up Shift					4
F50D, L01x, L02x	-	±0.25	-	%FSS	
L05x, L10x, L20x, L30x, L60x	-	±0.15	-	%FSS	
Offset Position Sensitivity (±1g)					-
F50D, L01x, L02x	-	±0.10	-	%FSS	
L05x, L10x, L20x, L30x, L60x	-	±0.05	-	%FSS	
Offset Long Term Drift (One Year)					-
F50D, L01x, L02x	-	±0.25	-	%FSS	
L05x, L10x, L20x, L30x, L60x	-	±0.15	-	%FSS	
Linearity, Hysteresis Error					6
F50D	-	±0.30	-	%FSS	
LxxD	-	±0.25	-	%FSS	
LxxG	-	±0.10	-	%FSS	
Response Delay					5, 9
Sleep - Wake Pressure	-	0.40	0.50	ms	
Sleep - Wake All	-	1.10	1.40	ms	
Power-On to First Reading Attempt	6.0 + 1 update period	-	-	ms	
Update Rate					5
Fast	-	0.40	1.0	ms	
Noise Reduced	-	1.30	3.1	ms	
Low Power	-	6.5	9.5	ms	
Digital Resolution					-
Output Resolution	-	14	-	bit	
No Missing Codes	12	13	-	bit	
Temperature Output					7
Resolution	-	11	-	bit	
Overall Accuracy	-	2	-	°C	
Current Requirement (3.3V Option)					5
Fast	-	3.5	4.3	mA	
Noise Reduced	-	3.6	4.5	mA	
Low Power	-	0.72	0.90	mA	
Sleep (Idle)	-	0.5	5.0	uA	
Current Requirement (5.0 Option)					5
Fast	-	5.0	6.0	mA	
Noise Reduced	-	5.2	6.2	mA	
Low Power	-	1.1	1.3	mA	
Sleep (Idle)	-	0.5	5.0	uA	

See following page for performance characteristics table notes

I2C / SPI Electrical Parameters for DLVR Series

Parameter	Symbol	Min	Typ	Max	Units	Notes
Input High Level	-	80.0	-	100	% of Vs	5
Input Low Level	-	0	-	20.0	% of Vs	5
Output Low Level	-	-	-	10.0	% of Vs	5
I2C Pull-up Resistor	-	1000	-	-	Ω	5,8
I2C Load Capacitance on SDA, @ 400 kHz	C _{SDA}	-	-	200	pF	5
I2C Input Capacitance (each pin)	C _{I2C_IN}	-	-	10.0	pF	5

Specification Notes

NOTE 1: THE SPAN IS THE ALGEBRAIC DIFFERENCE BETWEEN FULL SCALE DECIMAL COUNTS AND THE OFFSET DECIMAL COUNTS.

NOTE 1: Pressure Output Transfer Function:

$$Pressure(inH2O) = 1.25 \times \left(\frac{P_{out_dig} - OS_{dig}}{2^{14}} \right) \times FSS(inH2O)$$

Where,

P_{out_dig} Is the sensor 14 bit digital output.

OS_{dig} Is the specified digital offset (gage = 1,638 and differential = 8,192)

$FSS(inH2O)$ Is the sensor Full Scale Span in inH2O (gage = Full Scale Pressure, differential = 2 x Full Scale Pressure)

NOTE 2: TOTAL ERROR BAND CONSISTS OF OFFSET AND SPAN TEMPERATURE AND CALIBRATION ERRORS, LINEARITY AND PRESSURE HYSTERESIS ERRORS, OFFSET WARM-UP SHIFT, OFFSET POSITION SENSITIVITY AND LONG TERM OFFSET DRIFT ERRORS.

NOTE 3: SHIFT IS RELATIVE TO 25C.

NOTE 4: SHIFT IS WITHIN THE FIRST HOUR OF EXCITATION APPLIED TO THE DEVICE.

NOTE 5: PARAMETER IS CHARACTERIZED AND NOT 100% TESTED.

NOTE 6: MEASURED AT ONE-HALF FULL SCALE RATED PRESSURE USING BEST STRAIGHT LINE CURVE FIT.

NOTE 7: TEMPERATURE OUTPUT CONVERSION FUNCTION:

$$Temperature (°C) = T_{out_dig} \times \left(\frac{200}{2^{11} - 1} \right) - 50$$

NOTE 8: A PULL-UP RESISTOR IS REQUIRED FOR CORRECT I2C USAGE. THE MINIMUM VALUE INDICATED IS FOR 5.0V OR 3.3V OPERATION.

NOTE 9: FOLLOWING SENSOR POWER-UP, THE APPLICATION MUST WAIT AT LEAST THE INDICATED TIME BEFORE ATTEMPTING TO COMMUNICATE WITH THE SENSOR.

Device Options

The following is a list of factory programmable options. Consult the factory to learn more about the options.

Interface

I2C and SPI interfaces are available. NOTE: SPI interface is only available with eight (8) lead packages.

Supply Voltage

Devices are characterized at either 3.3V or 5.0V depending on the options selected. It is suggested to select the option that most closely matches the application supply voltage for best possible performance.

Speed/Power

There are four options of Speed/Power. These are Fast(F), Noise Reduced(N), Low Power(L) and Sleep mode(S).

Fast Mode(F) Is the fastest operating mode where the device operates with continuous sampling at the fastest internal speed.

Noise Reduced(N): Also operates with continuous samples however the ADC is set for over sampling for noise reduction. The conversion times are resultantly longer than the Fast(F) mode however, there is approximately 1/2 bit reduction in noise.

Low Power(L): Is similar to the Fast(F) mode with exception that the device uses an internal timer to delay between pressure conversions. The internal timer time-out triggers the next conversion cycle. The update rate is commensurately lower for this mode as a result.

Sleep(S): Is similar to the Low Power(L) mode however the trigger to initiate a sample comes from the user instead of an internal timer. This is ideal for very low update rate applications that require low power usage. It is also ideal for synchronizing the data conversions with the host microprocessor.

Coating

Parylene Coating: Parylene coating provides a moisture barrier and protection from some harsh media. Consult factory for applicability of Parylene for the target application and sensor type.

Operation Overview (Cont'd)

Table 1 - DLVR Control Logic Detail

Control Logic							
Power/Speed Option	Power/Speed Description	Operating Mode	Over Sample	Delay Between Samples	Normal ADC Cycles	Special ADC Cycles	Special ADC Cycle Interval
F	Fast	Free Running	No	No	1 (P)	1 (Z or T)	255
N	Noise Reduced		Yes	No	1 (P)	1 (Z or T)	255
L	Low Power		Yes	Yes	1 (P)	1 (Z or T)	31
S	Sleep ⁽¹⁾ (Wake Pressure)	Triggered	No	User Defined	1 (P)	n/a	Never
	Sleep (Wake All)		No	User Defined	1 (P)	2 (Z + T)	Always

Note 1) Wake from sleep with pressure only reading is not available with SPI interface (I2C only).

Figure 2 - DLVR Communication Model

Free Running Mode [(F)ast, (N)oise Reduced and (L)ow Power Option]

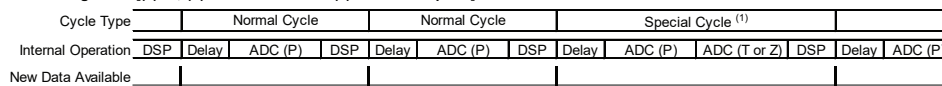

Note 1: See Table 1 for frequency of Special Cycles

Triggered Mode - Wake All [(S)leep Option]

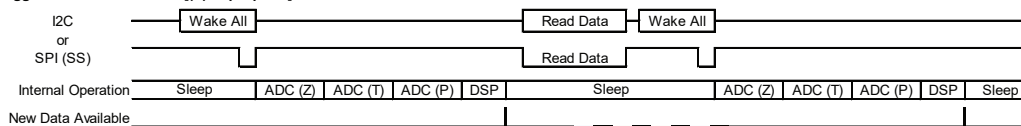

Triggered Mode - Wake Pressure [(S)leep Option]

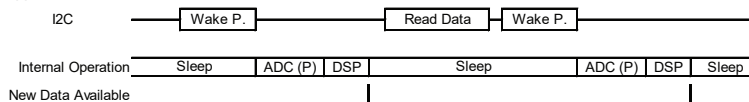

Digital Interface Data Format

For either type of digital interface, the format of data returned from the sensor is the same. The first 16 bits consist of the 2 Status bits followed by the 14-bit the pressure value. The third byte provides the 8 most significant bits of the measured temperature; the fourth byte provides the 3 least significant bits of temperature, followed by 5 bits of undefined filler data. With either interface, the host may terminate the transfer after receiving the first two bytes of data from the sensor, or following the third byte (if just the most-significant 8 bits of temperature are needed). Refer to Table 2 for the overall data format of the sensor. Table 3 shows the Status Bit definition.

Table 2 - Output Data Format

D[31:30]	D[29:24]	D[23:16]	D[15:8]	D[7:5]	D[4:0]
S[1:0]	P[13:8]	P[7:0]	T[10:3]	T[2:0]	X[4:0]
Status	Pressure MSB	Pressure LSB	Temperature MSB	Temperature LSB	Filler bits (Undefined)

Bit Definitions:

Status (S): Normal/command / busy / diagnostic

Pressure (P): Digital pressure reading

Temperature (T): Compensated temperature reading

Table 3- Status Bit Definitions

[00]	[01]	[10]	[11]
Current Data, no errors.	(Reserved)	Stale Data: Not updated since last read.	Error Condition: electrical fault or configuration invalid.

I2C Interface

I2C Communications Overview

The I2C interface uses a set of signal sequences for communication. The following is a description of the supported sequences and their associated mnemonics. Refer to Figure 3 for the associated usage of the following signal sequences.

Bus not Busy (I): During idle periods both data line (SDA) and clock line (SCL) remain HIGH.

START condition (ST): A HIGH to LOW transition of SDA line while the clock (SCL) is HIGH is interpreted as START condition. START conditions are always set by the master. Each initial request for a pressure value has to begin with a START condition.

Slave address (An): The I²C-bus requires a unique address for each device. The DLVR sensor has a preconfigured slave address (0x28). After setting a START condition the master sends the address byte containing the 7 bit sensor address followed by a data direction bit (R/W). A "0" indicates a transmission from master to slave (WRITE), a "1" indicates a data request (READ).

Acknowledge (A or N): Data is transferred in units of 8 bits (1 byte) at a time, MSB first. Each data-receiving device, whether master or slave, is required to pull the data line LOW to acknowledge receipt of the data. The Master must generate an extra clock pulse for this purpose. If the receiver does not pull the data line down, a NACK condition exists, and the slave transmitter becomes inactive. The master determines whether to send the last command again or to set the STOP condition, ending the transfer.

DATA valid (Dn): State of data line represents valid data when, after a START condition, data line is stable for duration of HIGH period of clock signal. Data on line must be changed during LOW period of clock signal. There is one clock pulse per data bit.

DATA operation: The sensor starts to send 4 data bytes containing the current pressure and temperature values. The transmission may be halted by the host after any of the bytes by responding with a NACK.

STOP condition (P): LOW to HIGH transition of the SDA line while clock (SCL) is HIGH indicates a STOP condition. STOP conditions are always generated by the master.

I2C Communications Overview (Cont'd)

Figure 3 - I2C Communication Diagram

I2C Communications Diagram

1. Start All (to wake sensor from Sleep mode, Zero ADC, read Temperature and read Pressure)

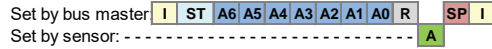

2. Start Pressure (to wake sensor from Sleep mode and read Pressure only)

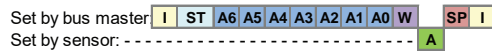

3. Read Data (with examples of reading pressure, pressure plus 8 bits of temperature and pressure plus 11 bits of temperature)

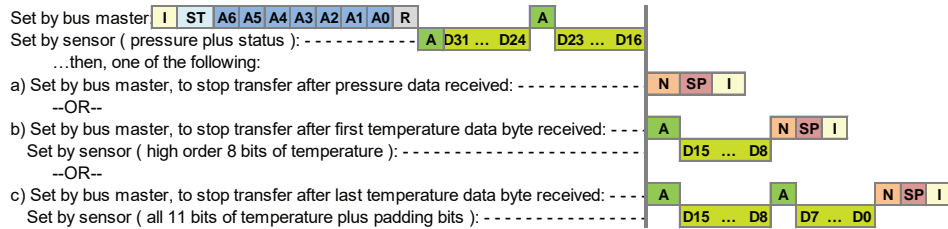

Bus states	
Idle:	I
Start:	ST
Stop:	SP
Ack:	A
Nack:	N
"Read" bit (1):	R
"Write" bit (0):	W

Sensor Address	
A6 ... A0	
Default:	0x28

Data format	
Status:	D31 D30
Pressure data:	D29 ... D16
Temperature data:	D15 ... D5
(padding bits):	D4 ... D0

Figure 3 illustrates the sequence of signals set by both the host and the sensor for each command. Note that for the DataRead command, the host has the option of responding to the second or third bytes of data with a NACK instead of ACK. This terminates the data transmission after the pressure data, or after the pressure data and upper byte of temperature, have been transmitted. See Figure 6 for the I2C timing details.

SPI Interface

SPI Command Sequence

DLVR sensors using the SPI interface option provide 3 signals for communication: SCLK, SS (Slave Select), and MISO. This read-only signaling uses a hardware protocol to control the sensor, differing slightly with the speed/power option selected as described below:

Fast(F), Noise Reduced(N) and Low-Power(L) Configurations: After power-up, the part enters Free Running mode and begins its periodic conversion cycle, at the interval determined by the programmed Power/Speed option. This is the simplest configuration. The only bus interaction with the host is the SPI DataRead operations. Polling the sensor at a rate slower than the internal update rate will minimize bus activity and ensure that new values are presented with each transfer. Note that the Status bits should still be checked to verify updated data and the absence of error conditions.

Sleep(S) Configuration: As with the I2C option, the part enters Triggered mode after power-up, and waits for a command from the bus master. To wake the part and start a measurement cycle, the SS pin must be driven low by the host for at least 8usec, then driven high. This can be done by shifting a dummy byte of 8 bits from the sensor. This bus activity can be considered the SPI StartAll command, where the rising edge of SS is the required input to start conversion. Updated conversion data is written to the output registers after a period dependent on configuration options (see Performance Characteristics). After this update of the registers, the core goes to an inactive (sleep) state. The DataRead command simply consists of shifting out 2, 3, or 4 bytes of data from the sensor. The host can check the Status bits of the output to verify that new data has been provided. The part remains inactive following this read operation, and another StartAll operation is needed to wake the part when the next conversion is to be performed.

SPI Bit Pattern

The sequence of bits and bus signals are shown in the following illustration (Figure 4). Refer to Figure 5 in the Interface Timing Diagram section for detailed timing data. As previously described, the incoming data may be terminated by raising SS after 2, 3, or 4 bytes have been received as illustrated below.

Figure 4 - SPI Bit Pattern

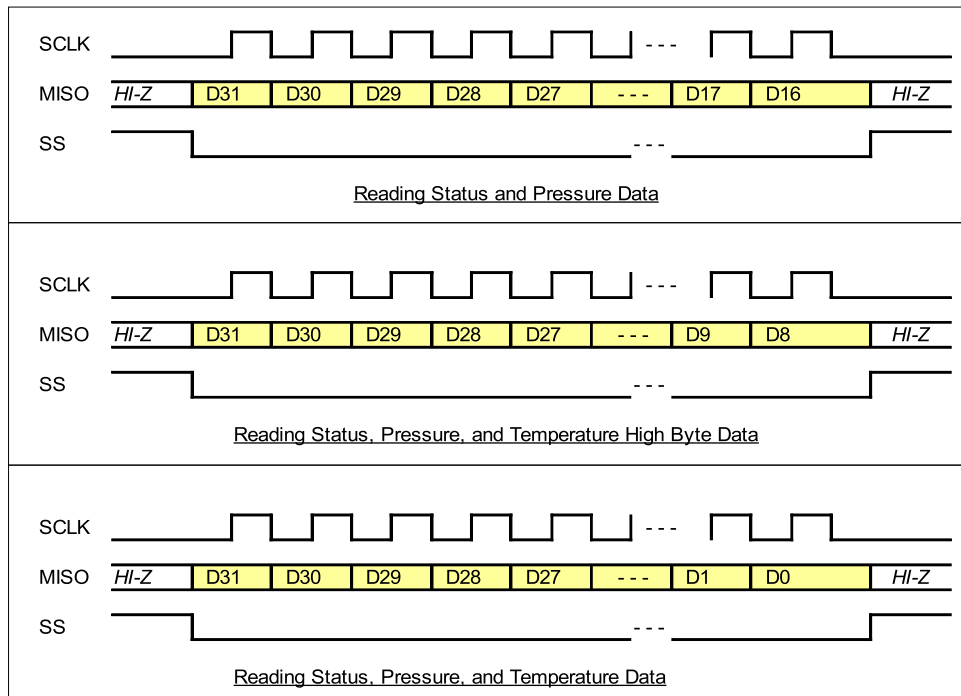

Interface Timing Diagrams

Figure 5 - SPI Timing Diagram

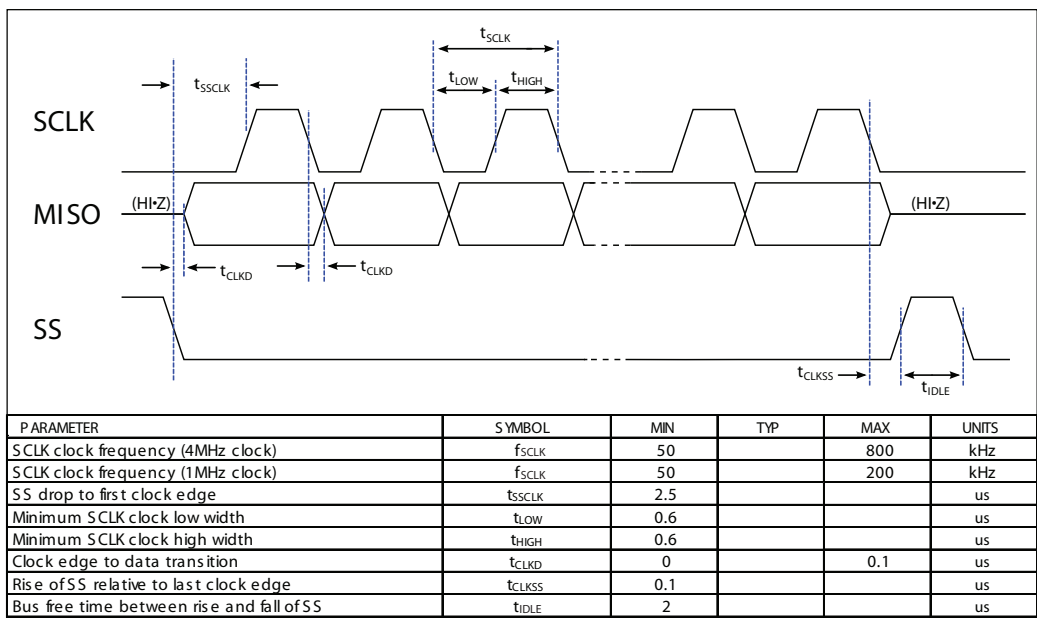
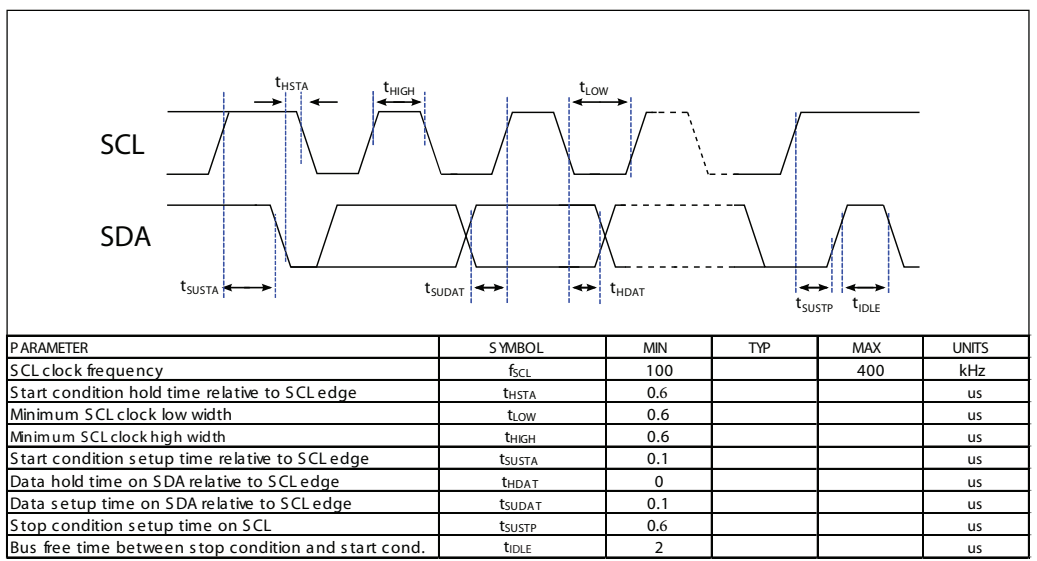

Figure 6 - I2C Timing Diagram



How to Order

Refer to Table 4 for configuring a standard base part number which includes the pressure range, package and temperature range. Table 5 shows the available configuring options. The option identifier is required to complete the device part number. Refer to Table 6 for the available device package options.

Example P/N with options: DLVR-L02D-E1NS-C-NI3F









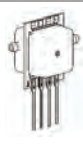

Table 4 - How to configure a base part number

ORDERING INFORMATION	SERIES	PRESSURE RANGE		PACKAGE				TEMPERATURE RANGE					
		ID	Description	Port Orientation		Lid Style		Lead Type					
				ID	Description	ID	Description	ID	Description	ID	Description		
DLVR	F50D	±0.5 inH2O	E	1	Dual Port Same Side	N	Non-Barbed	S	SIP	C	Commercial		
	L01D	±1 inH2O		2	Dual Port Opposite Side	B	Barbed	D	DIP			I	Industrial
	L02D	±2 inH2O							J			J-Lead SMT	
	L05D	±5 inH2O											
	L10D	±10 inH2O											
	L20D	±20 inH2O											
	L30D	±30 inH2O											
	L60D	±60 inH2O											
	L01G	0 to 1 inH2O											
	L02G	0 to 2 inH2O											
	L05G	0 to 5 inH2O											
	L10G	0 to 10 inH2O											
	L20G	0 to 20 inH2O											
L30G	0 to 30 inH2O												
L60G	0 to 60 inH2O												
Example	DLVR	L02D	E	1	N	S	C						

Table 5 - How to configure an option identifier

ORDERING INFORMATION	COATING		INTERFACE		SUPPLY VOLTAGE		SPEED/POWER	
	ID	Description	ID	Description	ID	Description	ID	Description
	N	No Coating	I	I2C	3	3.3V	F	Fast
P	Parylene Coating ^a	S	SPI	5	5.0V	N	Noise reduced	
						L	Low Power	
						S	Sleep Mode	
Example	N		I		3		F	

TABLE 6: Available E-Series Package Configurations

Port Orientation	Non-Barbed Lid Lead Style				Barbed Lid Lead Style			
	SIP	DIP	J Lead SMT	Low Profile DIP	SIP	DIP	J Lead SMT	Low Profile DIP
Dual Port Same Side	 E1NS	 E1ND	 E1NJ	N/A	 E1BS	 E1BD	N/A	N/A
Dual Port Opposite Side	 E2NS	 E2ND	 E2NJ	N/A	 E2BS	 E2BD	N/A	N/A
Single Port (Gage)	N/A	N/A	N/A	N/A	N/A	N/A	N/A	N/A

Specification Notes (Cont.)

NOTE 8: PARYLENE COATING NOT OFFERED IN J-LEAD SMT CONFIGURATION.

Package Drawings

E1NS Package

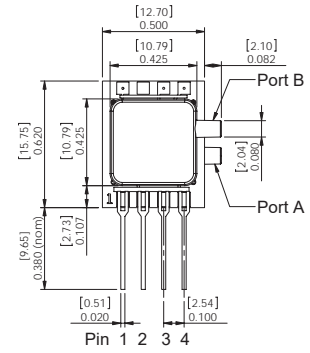
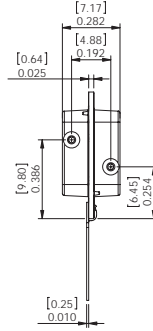
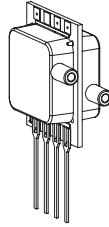

Pinout

- 1) Gnd
- 2) Vs
- 3) SDA
- 4) SCL

NOTES

- 1) Dimensions are in inches (mm)
- 2) For suggested pad layout, see drawing: PAD-01

E1BS Package

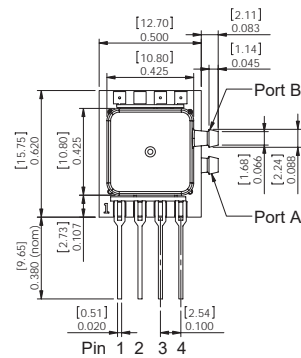
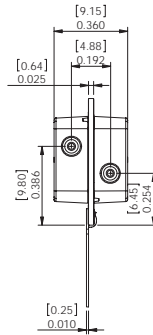
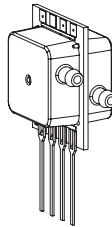

Pinout

- 1) Gnd
- 2) Vs
- 3) SDA
- 4) SCL

NOTES

- 1) Dimensions are in inches (mm)
- 2) For suggested pad layout, see drawing: PAD-01

Package Drawings (Cont'd)

E2NS Package

Pinout
 1) Gnd
 2) Vs
 3) SDA
 4) SCL

NOTES
 1) Dimensions are in inches [mm]
 2) For suggested pad layout, see drawing: PAD-01

E2BS Package

Pinout
 1) Gnd
 2) Vs
 3) SDA
 4) SCL

NOTES
 1) Dimensions are in inches [mm]
 2) For suggested pad layout, see drawing: PAD-01

Package Drawings (Cont'd)

E1ND Package

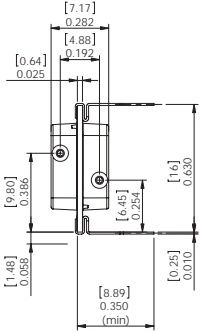
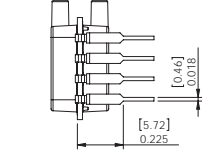
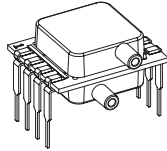

Pinout

- 1) Gnd
- 2) Vs
- 3) SDA/MISO
- 4) SCL/SCLK
- 5) INT/SS
- 6) Do Not Connect
- 7) Do Not Connect
- 8) Do Not Connect

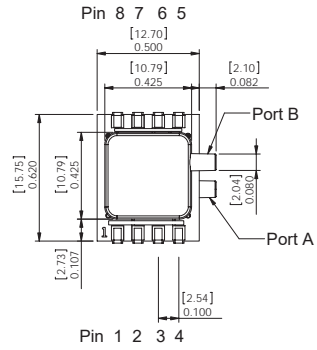

NOTES

- 1) Dimensions are in inches [mm]
- 2) For suggested pad layout, see drawing: PAD-03

E1BD Package

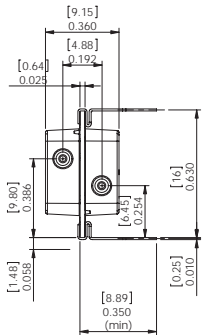
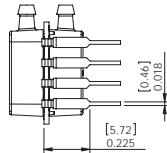
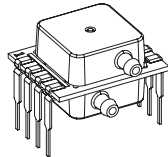

Pinout

- 1) Gnd
- 2) Vs
- 3) SDA/MISO
- 4) SCL/SCLK
- 5) INT/SS
- 6) Do Not Connect
- 7) Do Not Connect
- 8) Do Not Connect

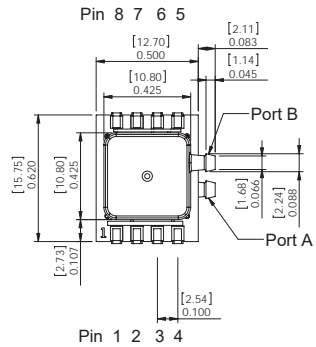

NOTES

- 1) Dimensions are in inches [mm]
- 2) For suggested pad layout, see drawing: PAD-03

ALL SENSORS

www.allsensors.com

P 408 225 4314

F 408 225 2079

A 16035 Vineyard Blvd. Morgan Hill, CA 95037

Package Drawings (Cont'd)

E2ND Package

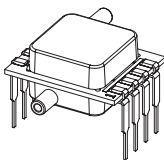
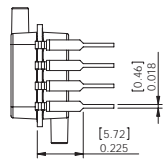
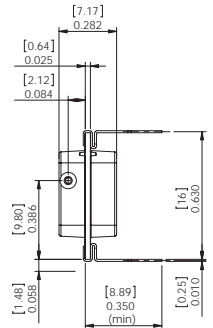
Pinout

- 1) Gnd
- 2) Vs
- 3) SDA/MISO
- 4) SCL/SCLK
- 5) INT/SS
- 6) Do Not Connect
- 7) Do Not Connect
- 8) Do Not Connect

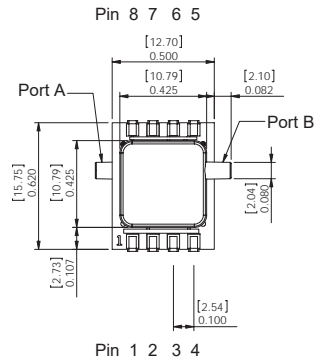

NOTES

- 1) Dimensions are in inches [mm]
- 2) For suggested pad layout, see drawing: PAD-03

E2BD Package

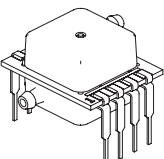
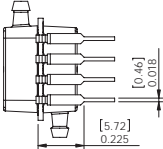
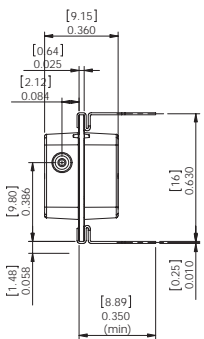
Pinout

- 1) Gnd
- 2) Vs
- 3) SDA/MISO
- 4) SCL/SCLK
- 5) INT/SS
- 6) Do Not Connect
- 7) Do Not Connect
- 8) Do Not Connect

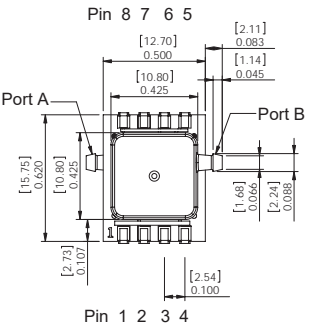

NOTES

- 1) Dimensions are in inches [mm]
- 2) For suggested pad layout, see drawing: PAD-03

Package Drawings (Cont'd)

E1NJ Package

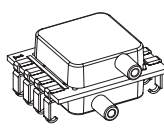

Pinout

- 1) Gnd
- 2) Vs
- 3) SDA/MISO
- 4) SCL/SCLK
- 5) INT/SS
- 6) Do Not Connect
- 7) Do Not Connect
- 8) Do Not Connect

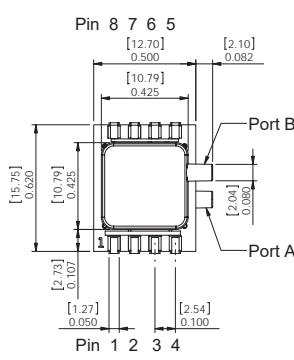
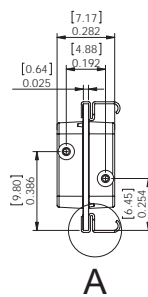
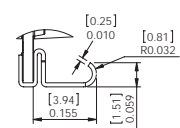
DETAIL A
SCALE 4 : 1

NOTES
 1) Dimensions are in inches [mm]
 2) For suggested pad layout, see drawing: PAD-10

E2NJ Package

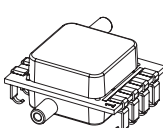

Pinout

- 1) Gnd
- 2) Vs
- 3) SDA/MISO
- 4) SCL/SCLK
- 5) INT/SS
- 6) Do Not Connect
- 7) Do Not Connect
- 8) Do Not Connect

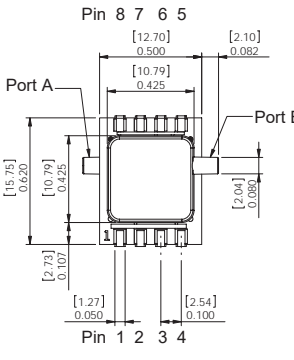
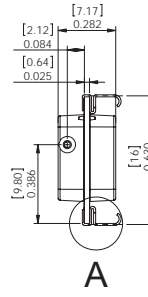
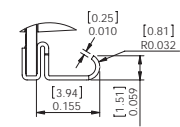
DETAIL A
SCALE 4 : 1

NOTES
 1) Dimensions are in inches [mm]
 2) For suggested pad layout, see drawing: PAD-10

Suggested Pad Layout

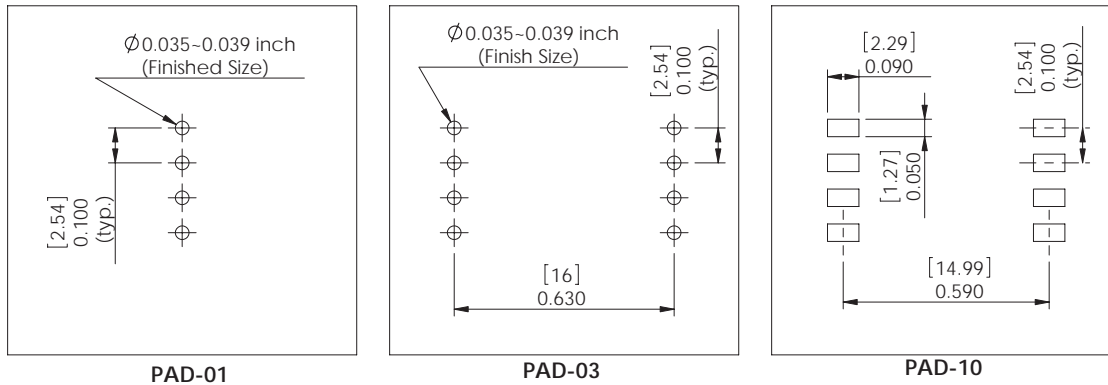

Product Labeling

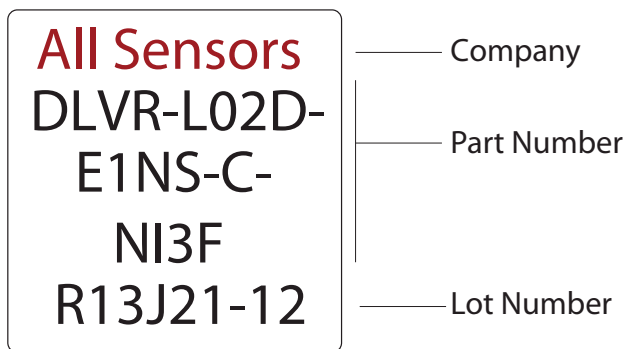

Example Device Label

All Sensors reserves the right to make changes to any products herein. All Sensors does not assume any liability arising out of the application or use of any product or circuit described herein, neither does it convey any license under its patent rights nor the rights of others.

DLC — COMPACT HIGH-RESOLUTION PRESSURE SENSORS

General Description

The DLC Series Compact High Resolution Digital Output Sensor product family is based on All Sensors' proprietary CoBeam²™ Technology. This reduces package stress susceptibility, resulting in improved overall long term stability and vastly improved position sensitivity.





The digital interface options ease integration of the sensors into a wide range of process control and measurement systems, allowing direct connection to serial communications channels. For battery-powered systems, the sensors can enter very low-power modes between readings to minimize load on the power supply. With the ability to operate at a low, variable supply voltage from 1.68V to 3.6V without the loss of accuracy. The DLC Series renders itself a power conscious device, well suited for portable applications. As a result, the sensor can operate directly from a battery, with no loss in performance.

These calibrated and compensated sensors provide accurate, stable output over a wide temperature range. This series is intended for use with non-corrosive, non-ionic working fluids such as clean air or dry gases and the like.

Features

- All Sensors CoBeam²™ Technology
- Low and High Pressure offerings
- High Resolution 16 bit Output
- I2C Interface
- Compact Packages
- Differential, Gage & Absolute pressure types

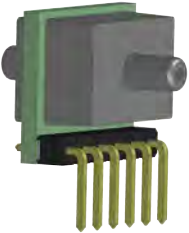
Compact Packages

Differential	Gage	Absolute
 D1	 U1	 U5
 D3	 U2	
 D4		

Available in 2018

ALL SENSORS

ALL SENSORS

E www.allsensors.com

F 408 225 2079

P 408 225 4314

A 16035 Vineyard Blvd., Morgan Hill, CA 95037



DIGITAL OUTPUT PRESSURE SENSORS

Enhanced Digital Output Sensors

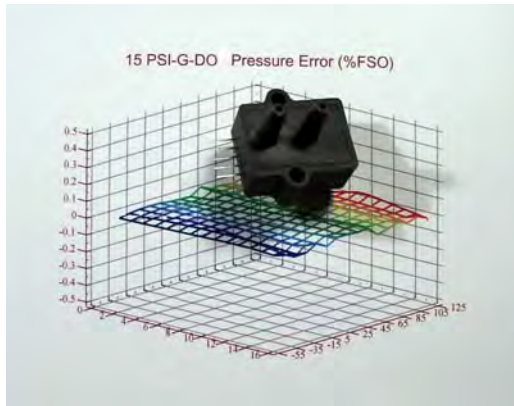

Features

- 5" H₂O to 100psi Pressure Ranges
- All Combined Errors Over Temperature Less Than 0.1%, Typical
- Wide -20 to 85°C Compensated Temperature Range
- Electrically Compatible to All Sensors GA142 Series
- Enhanced Dual Serial Interface Mode

Applications

- Medical Instrumentation
- Environmental Controls
- HVAC
- Meteorology

General Description

The Digital Output pressure sensors are based upon a proprietary surface mapping technology to produce a fully digital output that virtually eliminates all repeatable errors over temperature and pressure. This series provides a 12 bit digital serial output (14 bit in High Resolution Mode) with superior offset, span and linearity characteristics. The output is SPI and MICROWIRE/PLUS[®] compatible as well as fully compatible with the All Sensors GA142 Series sensors.

In addition to synchronous communications, the Digital Output pressure sensors incorporates a bi-directional, TTL level, asynchronous serial interfaces mode (hardware selectable 9,600 or 19,200 baud). This mode includes a command set that allows the host to interrogate the sensor for model information, pressure range, serial number, pressure units and conversion factor. The command set also allows the host to select a high resolution output mode, make minor adjustments to offset and has an addressable feature that allows multiple sensors to be tied to the same interface buss.

This series is intended for use with non-corrosive, non-ionic working fluids such as air, dry gases and the like. All signals are 5V TTL/CMOS compatible.

Physical Dimensions

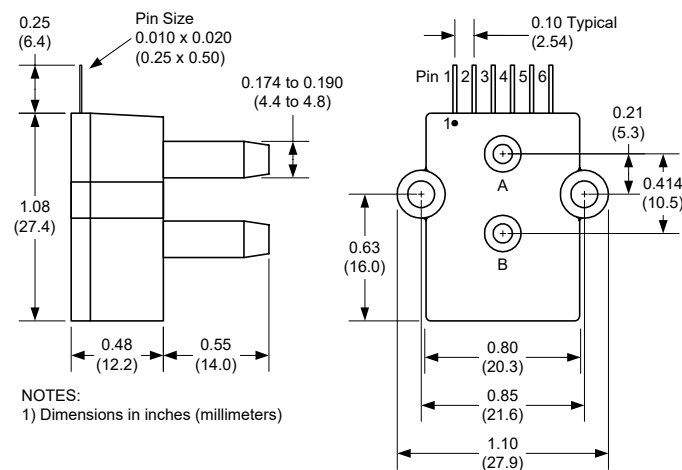

Pin Descriptions

Pin	Label	Description
1	Vcc	+5V power supply input
2	Data/SI	Data output for synchronous mode. Serial in for asynchronous mode.
3	Clock/SO	Clock output for synchronous mode. Serial out for asynchronous mode.
4	Ready/Mode	Ready output for synchronous mode. Selects asynchronous mode when held low during reset.
5	Convert/BR	Convert input for synchronous mode. Selects one of two baud rates for asynchronous mode (low=9,600, high=19,200).
6	Ground	Ground for power and signals



Absolute Maximum Ratings

Supply Voltage (Vcc)	7Vdc
Voltage on Any Pin with Respect to Gnd	-0.6 to Vcc+0.6V
Common-mode pressure	50 psig
Lead Temperature (soldering 2-4 sec.)	250°C

Environmental Specifications

Operating Voltage	+4.75Vdc to +5.25Vdc
Compensated Temperature	-20° C to +85° C
Operating Temperature	-25 to +90° C
Storage Temperature	-40 to 125° C
Humidity Limits	0 to 95% RH (non condensing)

Standard Pressure Ranges

Part Number	Operating Pressure	Units	FSO ⁽²⁾	Digital Span ⁽⁴⁾	Proof Pressure	Burst Pressure
5 INCH-D-DO	-5 to 5	inH2O	5	1	200inH2O	300inH2O
10INCH-D-DO	-10 to 10	inH2O	10	1	200inH2O	300inH2O
1 PSI-D-DO	-1 to 1	PSI	1	1	200inH2O	300inH2O
5 PSI-D-DO	-5 to 5	PSI	5	1	10 PSI	30 PSI
15 PSI-D-DO	-15 to 15	PSI	15	1	60 PSI	120 PSI
15 PSI-A-DO	0 to 15	PSIA	15	2	60 PSI	120 PSI
30PSI-D-DO	-30 to 30	PSI	30	2	90 PSI	150 PSI
30 PSI-A-DO	0 to 30	PSIA	30	2	90 PSI	150 PSI
100PSI-D-DO	-100 to 100	PSI	100	2	200 PSI	250 PSI
100 PSI-A-DO	0 to 100	PSIA	100	2	200 PSI	250 PSI

General Performance Characteristics (All Models)

Parameter ⁽¹⁾	Minimum	Nominal	Maximum	Units
Resolution	12	--	--	Bit
Conversion Speed	--	8	16	mS
Supply Current	--	8	12	mA

Performance Characteristics for 5 INCH-D-DO

Parameter ⁽¹⁾	Minimum	Nominal	Maximum	Units
Overall Accuracy ⁽⁵⁾	--	0.25	0.5	%FSO
Long Term Drift (one year)	--	--	0.5	%FSO
Offset Position Sensitivity (1g)	--	--	0.05	%FSO
Offset Warm-up Shift ⁽³⁾	--	--	0.25	%FSO

Performance Characteristics for 10 INCH-D-DO and 1 PSI-D-DO

Parameter ⁽¹⁾	Minimum	Nominal	Maximum	Units
Overall Accuracy ⁽⁵⁾	--	0.25	0.5	%FSO
Long Term Drift (one year)	--	--	0.5	%FSO
Offset Position Sensitivity (1g)	--	--	0.03	%FSO
Offset Warm-up Shift ⁽³⁾	--	--	0.25	%FSO

Performance Characteristics for 5 PSI-D-DO through 100 PSI-x-DO

Parameter ⁽¹⁾	Minimum	Nominal	Maximum	Units
Overall Accuracy ⁽⁵⁾	--	0.10	0.25	%FSO
Long Term Drift (one year)	--	--	0.25	%FSO

Specification Notes

- NOTE 1: UNLESS OTHERWISE SPECIFIED, ALL PARAMETERS ARE MEASURED AT 5.0 VOLT SUPPLY, POSITIVE PRESSURE APPLIED TO PORT B.
- NOTE 2: THE DIGITAL OUTPUT IS A 16 BIT SIGNED BINARY OUTPUT IN A TWO'S COMPLIMENT FORMAT. THE APPLIED PRESSURE IS COMPUTED USING THE PRESSURE CONVERSION TABLE (BELOW). THE MODE COLUMN IDENTIFIES THE RESOLUTION OPERATING MODE OF THE DEVICE (A = STANDARD RESOLUTION, B = HIGH RESOLUTION). FSO AND UNITS ARE SHOWN FOR EACH MODEL.
- NOTE 3: SHIFT IS WITHIN THE FIRST HOUR OF EXCITATION APPLIED TO THE DEVICE.
- NOTE 4: DIGITAL SPAN IS DEPENDENT ON THE RESOLUTION OPERATING MODE. REFER TO THE DIGITAL SPAN TABLE (BELOW) TO IDENTIFY THE DIGITAL SPAN OF THE SPECIFIC MODEL. IN THE EVENT OF AN OVER-PRESSURE OR UNDER-PRESSURE CONDITION, THE DIGITAL OUTPUT WILL ONE COUNT HIGHER OR ONE COUNT LOWER (RESPECTIVELY) TO THE LISTED DIGITAL SPAN TO INDICATE THE CONDITION.
- NOTE 5: OVERALL ACCURACY INCLUDES THE COMBINED EFFECTS OF OFFSET AND SPAN SHIFTS OVER TEMPERATURE, LINEARITY, HYSTERESIS, AND OFFSET AND SPAN CALIBRATION.

Synchronous Timing Diagram (Note: Asynchronous mode timing is per RS-232. To use RS-232 requires the Maxim MA232 interface circuit for proper voltage level compatibility.)

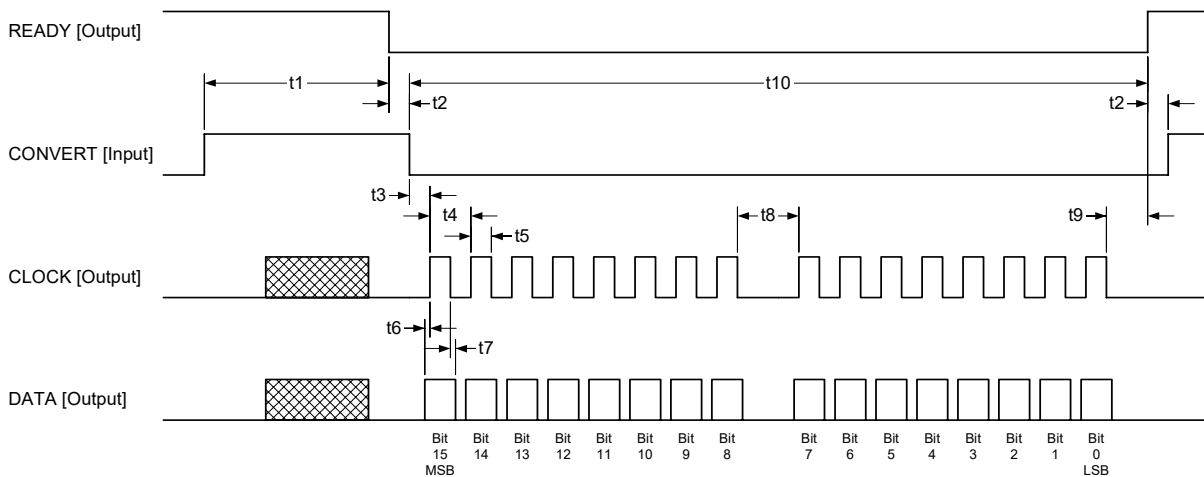

Ref	Parameter	Min	Typ	Max	Units
t1	Conversion Time	--	8	16	msec
t2	Ready to Convert	0	--	--	usec
t3	Convert to Clock	24	32	39	usec
t4	Clock Period	--	24	--	usec
t5	Clock High Time	--	12	--	usec

Ref	Parameter	Min	Typ	Max	Units
t6	Data Setup Time	--	3	--	usec
t7	Data Hold Time	--	3	--	usec
t8	Interbyte Delay	--	70	--	usec
t9	Clock to Ready	--	14	--	usec
t10	Data Transmission	--	476	--	usec

Typical Configurations

Synchronous Communications

Typical synchronous communications configuration (compatible with All Sensors GA142 Series Digital Output Sensors).

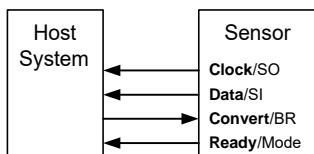

Asynchronous Communications

Typical asynchronous communications configuration. The Mode pin is interrogated at power up and if tied low, will cause the sensor to enter asynchronous communications mode. This mode supports multiple sensors by addressable commands. The Convert/BR pin then serves to select one of two available baud rates.

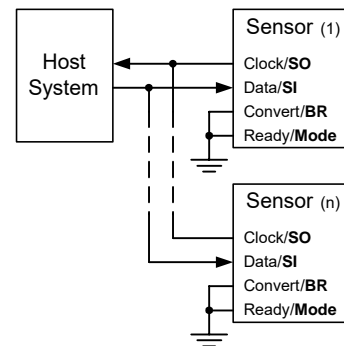

Command Summary Table:

Command	Description	Response
RA<cr>	Read Accuracy String	RA=[Accuracy String]<cr>
RC<cr>	Read Captured Pressure	RC=[hhh]<sp>[eeee]<cr>
RH<cr>	Read High Resolution Pressure	RH=[hhh]<sp>[eeee]<cr>
RL<cr>	Read Low Resolution Pressure	RL[IIII]<sp>[eeee]<cr>
RM<cr>	Read Model	RM=[Model String]<cr>
RR<cr>	Read Pressure Range	RR=[pressure Range String]<cr>
RS<cr>	Read Serial Number	RS=[S/N String]<cr>
RT<cr>	Read Temperature	RT=[Temperature Range String]<cr>
U[S/N String][Command]<cr>	Unique Command	For Matching S/N U[S/N String],sp>[Response String] For Non-matching S/N {null}
WC<cr>	Capture Pressure	{null}

Notations:

- <> indicates a single ascii character
- [] indicates an ascii string
- { } text within the braces describes the response (this is essentially a comment)
- "" text within quotes represents a literal ascii text string

Definitions:

Term	Name	Description
<cr>	Carriage Return	ascii Carriage Return. This is a command/response delimiter
<sp>	Space	ascii Space Character
[Accuracy String]	Accuracy String	Part accuracy string. Given in % full scale output. Example: 0.250 %FSO Notes: 1.) There is a space between the numeric accuracy "0.250" and units "%FSO." 2.) FSO stands for Full Scale Output (full scale output is determined by the Pressure Range String.)
[hhh]	High Resolution Output	This is a four character ascii string representing a hexadecimal value. Example: 3F7C Represents an output count of 16,252 Note: the output is forced to "8000" upon an error. except error bit 8, see error bit codes.
[IIII]	Low Resolution Output	This is a four character ascii string representing a hexadecimal value. Example: 1D58 Represents an output count of 7,512 Note: the output is forced to "8000" upon an error. except error bit 8, see error bit codes.
[Model String]	Model String	Part Model as given in the data sheet (also order number.) The general model syntax is [Full Scale Pressure]<sp>[Pressure Units]-[Pressure Model]-DO Example: 100 PSI-D-DO Where: Full Scale Pressure=100 Pressure Units=PSI (inH2O, mbar or mmHg available) DO represents Digital Output Notes: 1.) Exception to this syntax is the Barometer. 2.) Custom models may be different.

Definitions:

Term	Name	Description																										
[Pressure Range String]	Pressure Range String	This is the compensated pressure range of the part. Syntax: [low limit]<sp>"to"<sp>[high limit]<sp>[units][mode] Example: 20 to 32 mmHgA Where: Low limit = 20 High limit = 32 Units = mmHg Mode = A (absolute pressure) (D differential and G gage pressure also available.)																										
[Response String]	A Fully Formed Response String	Example: "RL=1E43<sp>0000<cr>																										
[S/N String]	Serial Number String	<p>YMDD-NN-BSPP (12 character String) Where: Y : Year (0-9) M : Month (A-M, excluding I) DD: Day of Month NN: Lot (lot sequence for a given day) B : Lot Batch# (A-Z) S : Test Oven Slot# (1-5) P : Position on Slot (1-15) Example: 3D23-03-A103</p> <p>April 23, 2003 3rd lot of the day Batch A, Slot 1, Position 03 This allows traceability to original test data</p> <table border="1" style="float: right;"> <thead> <tr> <th colspan="2">Month Codes</th> </tr> </thead> <tbody> <tr><td>January</td><td>: A</td></tr> <tr><td>February</td><td>: B</td></tr> <tr><td>March</td><td>: C</td></tr> <tr><td>April</td><td>: D</td></tr> <tr><td>May</td><td>: E</td></tr> <tr><td>June</td><td>: F</td></tr> <tr><td>July</td><td>: G</td></tr> <tr><td>August</td><td>: H</td></tr> <tr><td>September</td><td>: J</td></tr> <tr><td>October</td><td>: K</td></tr> <tr><td>November</td><td>: L</td></tr> <tr><td>December</td><td>: M</td></tr> </tbody> </table>	Month Codes		January	: A	February	: B	March	: C	April	: D	May	: E	June	: F	July	: G	August	: H	September	: J	October	: K	November	: L	December	: M
Month Codes																												
January	: A																											
February	: B																											
March	: C																											
April	: D																											
May	: E																											
June	: F																											
July	: G																											
August	: H																											
September	: J																											
October	: K																											
November	: L																											
December	: M																											
[Temperature Range String]	Temperature Range String	This is the compensated temperature range of the part. Syntax: [low limit]<sp>[high limit]<sp>"C" Example: -20 to 85 C -40 to 125 C and custom ranges also available.																										
[eeee]	Error Codes	<p>The error codes are bits packed within a double byte. The four character string is an ascii hex expression. The error code bits are: Bit 0 : Part not factory compensated Bit 1 : Tdex Overflow Bit 2 : Tdex Over-range Bit 3 : Pdex Overflow Bit 4 : Pdex Over-range Bit 5 : PWL Overflow Bit 6 : Scale Overflow Bit 7 : High Resolution Overflow Bit 8 : Pressure Output Limited to Specific Value Bits 9 through 15 : Reserved</p> <p>Example: 0100 Represents erro bit 8 set and the Pressure Output Limited</p> <p>Notes: Bit 0 : This should not appear if the part has been calibrated Bits 1 thru 7 : indicate computational error when compensated Bit 8 : indicates that the pressure applied to the part exceeds the range of the part and is limit to either the high or low limit</p>																										
{null}	Null Response	No response from the part. In the event of a serial number mismatch the part will not respond (to avoid buss contention.)																										

All Sensors reserves the right to make changes to any products herein. All Sensors does not assume any liability arising out of the application or use of any product or circuit described herein, neither does it convey any license under its patent rights nor the rights of others.

® MICROWIRE/PLUS IS A REGISTERED TRADEMARK OF NATIONAL SEMICONDUCTOR.



DIGITAL OUTPUT PRESSURE SENSORS

Enhanced Digital Output Sensors MILITARY GRADE

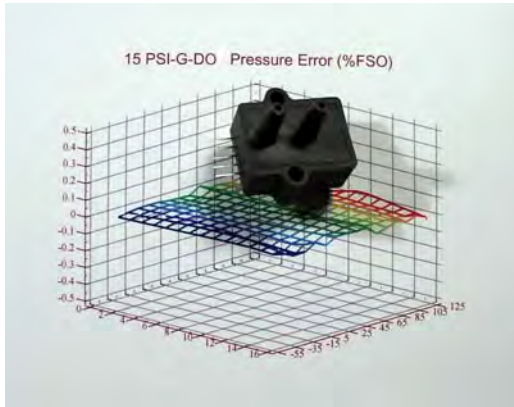

Features

- 5" H₂O to 100psi Pressure Ranges
- All Combined Errors Over Temperature Less Than 0.1%, Typical
- Wide -40 to 125°C Compensated Temperature Range
- Electrically Compatible to All Sensors GA142 Series
- Enhanced Dual Serial Interface Mode

Applications

- Medical Instrumentation
- Environmental Controls
- HVAC
- Meteorology

General Description

The Digital Output pressure sensors are based upon a proprietary surface mapping technology to produce a fully digital output that virtually eliminates all repeatable errors over temperature and pressure. This series provides a 12 bit digital serial output (14 bit in High Resolution Mode) with superior offset, span and linearity characteristics. The output is SPI and MICROWIRE/PLUS[®] compatible as well as fully compatible with the All Sensors GA142 Series sensors.

In addition to synchronous communications, the Digital Output pressure sensors incorporates a bi-directional, TTL level, asynchronous serial interfaces mode (hardware selectable 9,600 or 19,200 baud). This mode includes a command set that allows the host to interrogate the sensor for model information, pressure range, serial number, pressure units and conversion factor. The command set also allows the host to select a high resolution output mode, make minor adjustments to offset and has an addressable feature that allows multiple sensors to be tied to the same interface buss.

This series is intended for use with non-corrosive, non-ionic working fluids such as air, dry gases and the like. All signals are 5V TTL/CMOS compatible.

Physical Dimensions

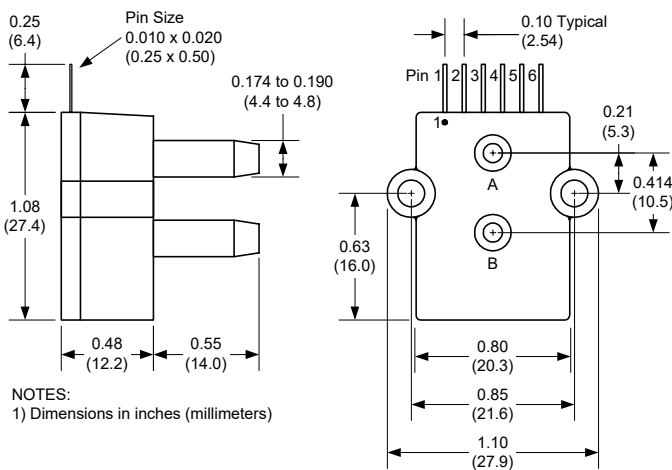

Pin Descriptions

Pin	Label	Description
1	Vcc	+5V power supply input
2	Data/SI	Data output for synchronous mode. Serial in for asynchronous mode.
3	Clock/SO	Clock output for synchronous mode. Serial out for asynchronous mode.
4	Ready/Mode	Ready output for synchronous mode. Selects asynchronous mode when held low during reset.
5	Convert/BR	Convert input for synchronous mode. Selects one of two baud rates for asynchronous mode (low=9,600, high=19,200).
6	Ground	Ground for power and signals



Absolute Maximum Ratings

Supply Voltage (Vcc)	7Vdc
Voltage on Any Pin with Respect to Gnd	-0.6 to Vcc+0.6V
Common-mode pressure	50 psig
Lead Temperature (soldering 2-4 sec.)	250°C

Environmental Specifications

Operating Voltage	+4.75Vdc to +5.25Vdc
Compensated Temperature	-40° C to +125° C
Operating Temperature	-40 to +125° C
Storage Temperature	-40 to 125° C
Humidity Limits	0 to 95% RH (non condensing)

Standard Pressure Ranges

Part Number	Operating Pressure	Units	FSO ⁽²⁾	Digital Span ⁽⁴⁾	Proof Pressure	Burst Pressure
5 INCH-D-DO-MIL	-5 to 5	inH2O	5	1	200 inH2O	300inH2O
10 INCH-D-DO-MIL	-10 to 10	inH2O	10	1	200inH2O	300inH2O
1 PSI-D-DO-MIL	-1 to 1	PSI	1	1	200inH2O	800inH2O
5 PSI-D-DO-MIL	-5 to 5	PSI	5	1	10 PSI	30 PSI
15 PSI-D-DO-MIL	-15 to 15	PSI	15	1	60 PSI	120 PSI
15 PSI-A-DO-MIL	0 to 15	PSIA	15	2	60 PSI	120 PSI
BARO-DO-MIL	600 to 1100	mBar	1100	3	60 PSI	120 PSI
30 PSI-D-DO-MIL	-30 to 30	PSI	30	2	90 PSI	150 PSI
30 PSI-A-DO-MIL	0 to 30	PSIA	30	2	90 PSI	150 PSI
100 PSI-D-DO-MIL	-100 to 100	PSI	100	2	200 PSI	250 PSI
100 PSI-A-DO-MIL	0 to 100	PSIA	100	2	200 PSI	250 PSI

General Performance Characteristics (All Models)

Parameter ⁽¹⁾	Minimum	Nominal	Maximum	Units
Resolution	12	--	--	Bit
Conversion Speed	--	8	16	mS
Supply Current	--	8	12	mA

Performance Characteristics for 5 INCH-D-DO

Parameter ⁽¹⁾	Minimum	Nominal	Maximum	Units
Overall Accuracy ⁽⁵⁾	--	0.5	1.0	%FSO
Long Term Drift (one year)	--	--	0.5	%FSO
Offset Position Sensitivity (1g)	--	--	0.05	%FSO
Offset Warm-up Shift ⁽³⁾	--	--	0.25	%FSO

Performance Characteristics for 10 INCH-D-DO and 1 PSI-D-DO

Parameter ⁽¹⁾	Minimum	Nominal	Maximum	Units
Overall Accuracy ⁽⁵⁾	--	0.5	1.0	%FSO
Long Term Drift (one year)	--	--	0.5	%FSO
Offset Position Sensitivity (1g)	--	--	0.03	%FSO
Offset Warm-up Shift ⁽³⁾	--	--	0.25	%FSO

Performance Characteristics for BARO-DO

Parameter ⁽¹⁾	Minimum	Nominal	Maximum	Units
Overall Accuracy ⁽⁵⁾	--	1.0	2.5	mBar
Long Term Drift (one year)	--	--	2.0	mBar

Performance Characteristics for 5 PSI-D-DO through 100 PSI-x-DO (except BARO-DO)

Parameter ⁽¹⁾	Minimum	Nominal	Maximum	Units
Overall Accuracy ⁽⁵⁾	--	0.25	0.5	%FSO
Long Term Drift (one year)	--	--	0.25	%FSO

Synchronous Timing Diagram (Note: Asynchronous mode timing is per RS-232. To use RS-232 requires the Maxim MA232 interface circuit for proper voltage level compatibility.)

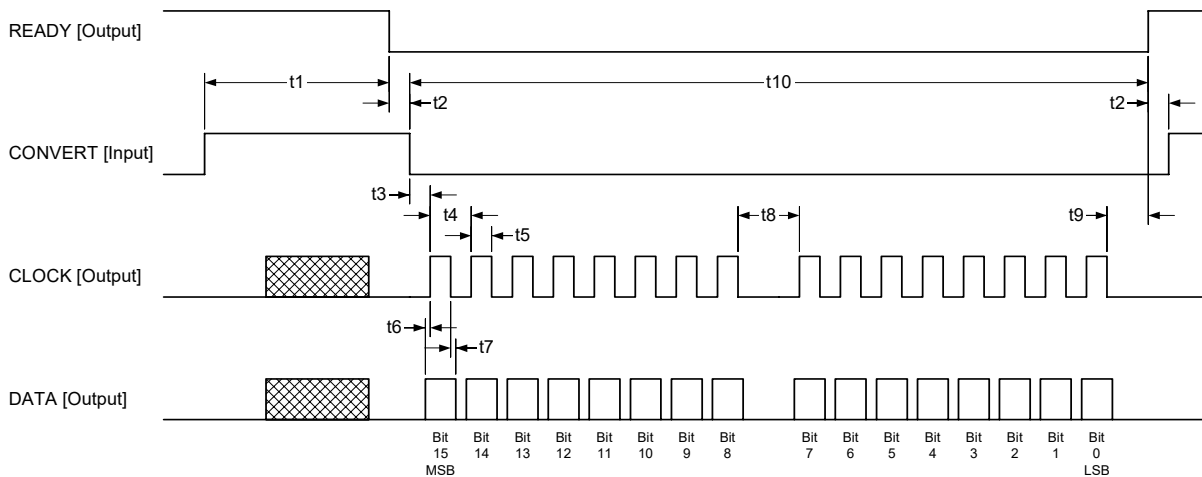

Ref	Parameter	Min	Typ	Max	Units
t1	Conversion Time	--	8	16	msec
t2	Ready to Convert	0	--	--	usec
t3	Convert to Clock	24	32	39	usec
t4	Clock Period	--	24	--	usec
t5	Clock High Time	--	12	--	usec

Ref	Parameter	Min	Typ	Max	Units
t6	Data Setup Time	--	3	--	usec
t7	Data Hold Time	--	3	--	usec
t8	Interbyte Delay	--	70	--	usec
t9	Clock to Ready	--	14	--	usec
t10	Data Transmission	--	476	--	usec

Typical Configurations

Synchronous Communications

Typical synchronous communications configuration (compatible with All Sensors GA142 Series Digital Output Sensors).

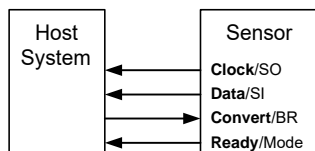

Asynchronous Communications

Typical asynchronous communications configuration. The Mode pin is interrogated at power up and if tied low, will cause the sensor to enter asynchronous communications mode. This mode supports multiple sensors by addressable commands. The Convert/BR pin then serves to select one of two available baud rates.

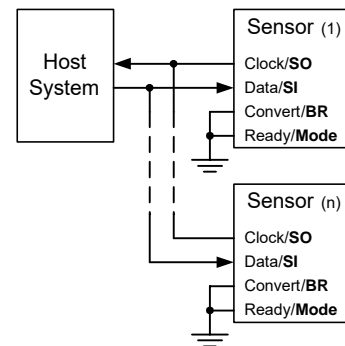

Command Summary Table:

Command	Description	Response
RA<cr>	Read Accuracy String	RA=[Accuracy String]<cr>
RC<cr>	Read Captured Pressure	RC=[hhh]<sp>[eeee]<cr>
RH<cr>	Read High Resolution Pressure	RH=[hhh]<sp>[eeee]<cr>
RL<cr>	Read Low Resolution Pressure	RL[llll]<sp>[eeee]<cr>
RM<cr>	Read Model	RM=[Model String]<cr>
RR<cr>	Read Pressure Range	RR=[pressure Range String]<cr>
RS<cr>	Read Serial Number	RS=[S/N String]<cr>
RT<cr>	Read Temperature	RT=[Temperature Range String]<cr>
U[S/N String][Command]<cr>	Unique Command	For Matching S/N U[S/N String],sp>[Response String] For Non-matching S/N {null}
WC<cr>	Capture Pressure	{null}

Notations:

<> indicates a single ascii character

[] indicates an ascii string

{ } text within the braces describes the response (this is essentially a comment)

"" text within quotes represents a literal ascii text string

Definitions:

Term	Name	Description
<cr>	Carriage Return	ascii Carriage Return. This is a command/response delimiter
<sp>	Space	ascii Space Character
[Accuracy String]	Accuracy String	Part accuracy string. Given in % full scale output. Example: 0.250%FSO Notes: 1.) There is a space between the numeric accuracy "0.250" and units "%FSO." 2.) FSO stands for Full Scale Output (full scale output is determined by the Pressure Range String.)
[hhh]	High Resolution Output	This is a four character ascii string representing a hexidecimal value. Example: 3F7C Represents an output count of 16,252 Note: the output is forced to "8000" upon an error. except error bit 8, see error bit codes.
[llll]	Low Resolution Output	This is a four character ascii string representing a hexidecimal value. Example: 1D58 Represents an output count of 7,512 Note: the output is forced to "8000" upon an error. except error bit 8, see error bit codes.
[Model String]	Model String	Part Model as given in the data sheet (also order number.) The general model syntax is [Full Scale Pressure]<sp>[Pressure Units]-[Pressure Model]-DO Example: 100 PSI-D-DO Where: Full Scale Pressure=100 Pressure Units=PSI (inH2O, mbar or mmHg available) DO represents Digital Output Notes: 1.) Exception to this syntax is the Barometer. 2.) Custom models may be different.

Definitions:

Term	Name	Description		
[Pressure Range String]	Pressure Range String	This is the compensated pressure range of the part. Syntax: [low limit]<sp>"to"<sp>[high limit]<sp>[units][mode] Example: 20 to 32 mmHgA Where: Low limit = 20 High limit = 32 Units = mmHg Mode = A (absolute pressure) (D differential and G gage pressure also available.)		
[Response String]	A Fully Formed Response String	Example: "RL=1E43<sp>0000<cr>		
[S/N String]	Serial Number String	<table border="1"> <tr> <td> YMDD-NN-BSPP (12 character String) Where: Y : Year (0~9) M : Month (A~M, excluding I) DD: Day of Month NN: Lot (lot sequence for a given day) B : Lot Batch# (A~Z) S : Test Oven Slot# (1~5) P : Position on Slot (1~15) Example: 3D23-03-A103 April 23, 2003 3rd lot of the day Batch A, Slot 1, Position 03 This allows traceability to original test data </td> <td> Month Codes January : A February : B March : C April : D May : E June : F July : G August : H September : J October : K November : L December : M </td> </tr> </table>	YMDD-NN-BSPP (12 character String) Where: Y : Year (0~9) M : Month (A~M, excluding I) DD: Day of Month NN: Lot (lot sequence for a given day) B : Lot Batch# (A~Z) S : Test Oven Slot# (1~5) P : Position on Slot (1~15) Example: 3D23-03-A103 April 23, 2003 3rd lot of the day Batch A, Slot 1, Position 03 This allows traceability to original test data	Month Codes January : A February : B March : C April : D May : E June : F July : G August : H September : J October : K November : L December : M
YMDD-NN-BSPP (12 character String) Where: Y : Year (0~9) M : Month (A~M, excluding I) DD: Day of Month NN: Lot (lot sequence for a given day) B : Lot Batch# (A~Z) S : Test Oven Slot# (1~5) P : Position on Slot (1~15) Example: 3D23-03-A103 April 23, 2003 3rd lot of the day Batch A, Slot 1, Position 03 This allows traceability to original test data	Month Codes January : A February : B March : C April : D May : E June : F July : G August : H September : J October : K November : L December : M			
[Temperature Range String]	Temperature Range String	This is the compensated temperature range of the part. Syntax: [low limit]<sp>[high limit]<sp>"C" Example: -20 to 85 C -40 to 125 C and custom ranges also available.		
[eeee]	Error Codes	The error codes are bits packed within a double byte. The four character string is an ascii hex expression. The error code bits are: Bit 0 : Part not factory compensated Bit 1 : Tdex Overflow Bit 2 : Tdex Over-range Bit 3 : Pdex Overflow Bit 4 : Pdex Over-range Bit 5 : PWL Overflow Bit 6 : Scale Overflow Bit 7 : High Resolution Overflow Bit 8 : Pressure Output Limited to Specific Value Bits 9 through 15 : Reserved Example: 0100 Represents error bit 8 set and the Pressure Output Limited Notes: Bit 0 : This should not appear if the part has been calibrated Bits 1 thru 7 : indicate computational error when compensated Bit 8 : indicates that the pressure applied to the part exceeds the range of the part and is limit to either the high or low limit		
{null}	Null Response	No response from the part. In the event of a serial number mismatch the part will not respond (to avoid buss contention.)		

Specification Notes

- NOTE 1: UNLESS OTHERWISE SPECIFIED, ALL PARAMETERS ARE MEASURED AT 5.0 VOLT SUPPLY, POSITIVE PRESSURE APPLIED TO PORT B.
- NOTE 2: THE DIGITAL OUTPUT IS A 16 BIT SIGNED BINARY OUTPUT IN A TWO'S COMPLEMENT FORMAT. THE APPLIED PRESSURE IS COMPUTED USING THE PRESSURE CONVERSION TABLE (BELOW). THE MODE COLUMN IDENTIFIES THE RESOLUTION OPERATING MODE OF THE DEVICE (A = STANDARD RESOLUTION, B = HIGH RESOLUTION). FSO AND UNITS ARE SHOWN FOR EACH MODEL.
- NOTE 3: SHIFT IS WITHIN THE FIRST HOUR OF EXCITATION APPLIED TO THE DEVICE.
- NOTE 4: DIGITAL SPAN IS DEPENDENT ON THE RESOLUTION OPERATING MODE. REFER TO THE DIGITAL SPAN TABLE (BELOW) TO IDENTIFY THE DIGITAL SPAN OF THE SPECIFIC MODEL. IN THE EVENT OF AN OVER-PRESSURE OR UNDER-PRESSURE CONDITION, THE DIGITAL OUTPUT WILL ONE COUNT HIGHER OR ONE COUNT LOWER (RESPECTIVELY) TO THE LISTED DIGITAL SPAN TO INDICATE THE CONDITION.
- NOTE 5: OVERALL ACCURACY INCLUDES THE COMBINED EFFECTS OF OFFSET AND SPAN SHIFTS OVER TEMPERATURE, LINEARITY, HYSTERESIS, AND OFFSET AND SPAN CALIBRATION.



DIGITAL OUTPUT BAROMETER SENSORS

Enhanced Digital Output Sensors: Industrial temperature range

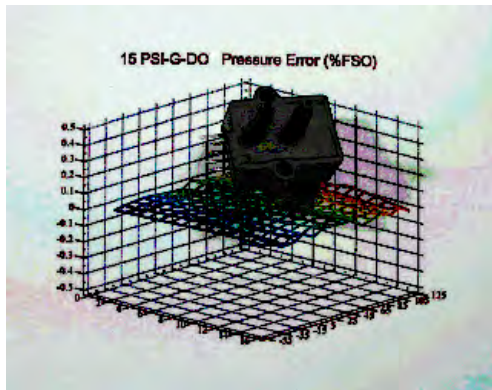

Features

- All Combined Errors Over Temperature Less Than 0.1%, Typical
- Wide -20 to 85°C Compensated Temperature Range
- Electrically Compatible to All Sensors GA142 Series
- Enhanced Dual Serial Interface Mode

Applications

- Medical Instrumentation
- Environmental Controls
- Meteorology

General Description

The Digital Output pressure sensors are based upon a proprietary surface mapping technology to produce a fully digital output that virtually eliminates all repeatable errors over temperature and pressure. This series provides a 12 bit digital serial output (14 bit in High Resolution Mode) with superior offset, span and linearity characteristics. The output is SPI and MICROWIRE/PLUS[®] compatible as well as fully compatible with the All Sensors GA142 Series sensors.

In addition to synchronous communications, the Digital Output pressure sensors incorporates a bi-directional, TTL level, asynchronous serial interfaces mode (hardware selectable 9,600 or 19,200 baud). This mode includes a command set that allows the host to interrogate the sensor for model information, pressure range, serial number, pressure units and conversion factor. The command set also allows the host to select a high resolution output mode, make minor adjustments to offset and has an addressable feature that allows multiple sensors to be tied to the same interface buss.

This series is intended for use with non-corrosive, non-ionic working fluids such as air, dry gases and the like. All signals are 5V TTL/CMOS compatible.

Physical Dimensions

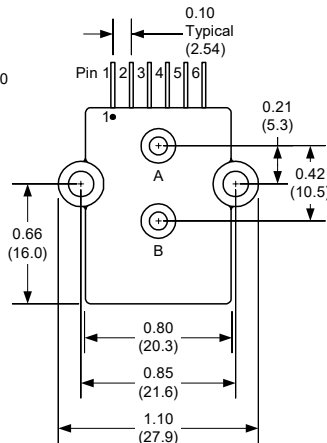
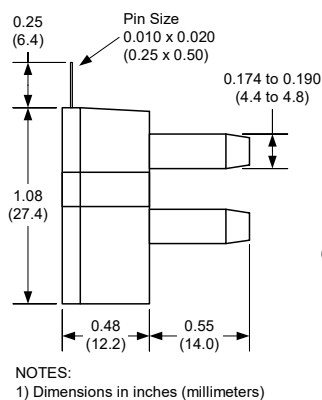

Pressure Applied to Port B

Pin Descriptions

Pin	Label	Description
1	Vcc	+5V power supply input
2	Data/SI	Data output for synchronous mode. Serial in for asynchronous mode.
3	Clock/SO	Clock output for synchronous mode. Serial out for asynchronous mode.
4	Ready/Mode	Ready output for synchronous mode. Selects asynchronous mode when held low during reset.
5	Convert/BR	Convert input for synchronous mode. Selects one of two baud rates for asynchronous mode (low=9,600, high=19,200).
6	Ground	Ground for power and signals

ALL SENSORS

DS-0010 REV A

ALL SENSORS

E www.allensors.com

F 408 225 2079

A 16035 Vineyard Blvd. Morgan Hill, CA 95037 P 408 225 4314



Absolute Maximum Ratings

Supply Voltage (Vcc)	7Vdc
Voltage on Any Pin with Respect to Gnd	-0.6 to Vcc+0.6V
Lead Temperature (soldering 2-4 sec.)	250°C

Environmental Specifications

Operating Voltage	+4.75Vdc to +5.25Vdc
Compensated Temperature	-20°C to +85°C
Operating Temperature	-20 to +105°C
Storage Temperature	-40 to 125°C
Humidity Limits	0 to 95% RH (non condensing)

Standard Pressure Ranges

Part Number	Operating Pressure	Units	Digital Span ⁽⁴⁾	Proof Pressure	Burst Pressure
BARO-DO	600 to 1100	mBar	3	60 PSI	120 PSI
BARO-INHG-DO	20 to 32	inches Hg	3	60 PSI	120 PSI

General Performance Characteristics

Parameter ⁽¹⁾	Minimum	Nominal	Maximum	Units
Resolution	12	--	--	Bit
Conversion Speed	--	8	16	mS
Supply Current	--	8	12	mA
Overall Accuracy ⁽⁵⁾	--	1.0	2.5	mBar
Long Term Drift (one year)	--	0.025	2.0	mBar

Specification Notes

- NOTE 1: UNLESS OTHERWISE SPECIFIED, ALL PARAMETERS ARE MEASURED AT 5.0 VOLT SUPPLY, POSITIVE PRESSURE APPLIED TO PORT B.
- NOTE 2: THE DIGITAL OUTPUT IS A 16 BIT SIGNED BINARY OUTPUT IN A TWO'S COMPLEMENT FORMAT. THE APPLIED PRESSURE IS COMPUTED USING THE PRESSURE CONVERSION TABLE (BELOW). THE MODE COLUMN IDENTIFIES THE RESOLUTION OPERATING MODE OF THE DEVICE (A = STANDARD RESOLUTION, B = HIGH RESOLUTION). FSO AND UNITS ARE SHOWN FOR EACH MODEL.
- NOTE 3: SHIFT IS WITHIN THE FIRST HOUR OF EXCITATION APPLIED TO THE DEVICE.
- NOTE 4: DIGITAL SPAN IS DEPENDENT ON THE RESOLUTION OPERATING MODE. REFER TO THE DIGITAL SPAN TABLE (BELOW) TO IDENTIFY THE DIGITAL SPAN OF THE SPECIFIC MODEL. IN THE EVENT OF AN OVER-PRESSURE OR UNDER-PRESSURE CONDITION, THE DIGITAL OUTPUT WILL ONE COUNT HIGHER OR ONE COUNT LOWER (RESPECTIVELY) TO THE LISTED DIGITAL SPAN TO INDICATE THE CONDITION.
- NOTE 5: OVERALL ACCURACY INCLUDES THE COMBINED EFFECTS OF OFFSET AND SPAN SHIFTS OVER TEMPERATURE, LINEARITY, HYSTERESIS, AND OFFSET AND SPAN CALIBRATION.

Synchronous Timing Diagram (Note: Asynchronous mode timing is per RS-232. To use RS-232 requires the Maxim MA232 interface circuit for proper voltage level compatibility.)

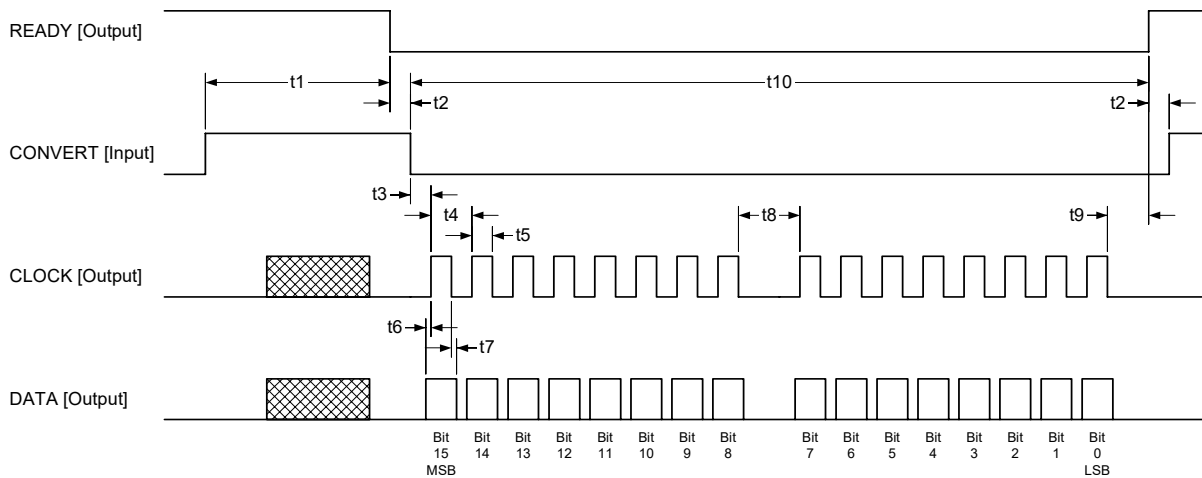

Ref	Parameter	Min	Typ	Max	Units
t1	Conversion Time	--	8	16	msec
t2	Ready to Convert	0	--	--	usec
t3	Convert to Clock	24	32	39	usec
t4	Clock Period	--	24	--	usec
t5	Clock High Time	--	12	--	usec

Ref	Parameter	Min	Typ	Max	Units
t6	Data Setup Time	--	3	--	usec
t7	Data Hold Time	--	3	--	usec
t8	Interbyte Delay	--	70	--	usec
t9	Clock to Ready	--	14	--	usec
t10	Data Transmission	--	476	--	usec

Typical Configurations

Synchronous Communications

Typical synchronous communications configuration (compatible with All Sensors GA142 Series Digital Output Sensors).

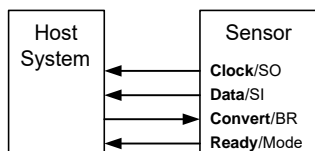

Asynchronous Communications

Typical asynchronous communications configuration. The Mode pin is interrogated at power up and if tied low, will cause the sensor to enter asynchronous communications mode. This mode supports multiple sensors by addressable commands. The Convert/BR pin then serves to select one of two available baud rates.

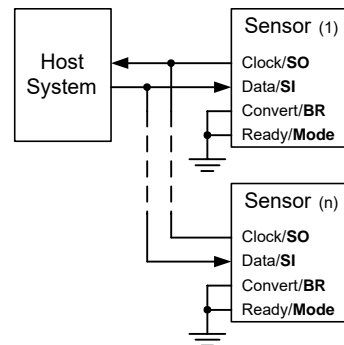

Command Summary Table:

Command	Description	Response
RA<cr>	Read Accuracy String	RA=[Accuracy String]<cr>
RC<cr>	Read Captured Pressure	RC=[hhhh]<sp>[eeee]<cr>
RH<cr>	Read High Resolution Pressure	RH=[hhhh]<sp>[eeee]<cr>
RL<cr>	Read Low Resolution Pressure	RL[llll]<sp>[eeee]<cr>
RM<cr>	Read Model	RM=[Model String]<cr>
RR<cr>	Read Pressure Range	RR=[pressure Range String]<cr>
RS<cr>	Read Serial Number	RS=[S/N String]<cr>
RT<cr>	Read Temperature	RT=[Temperature Range String]<cr>
U[S/N String][Command]<cr>	Unique Command	For Matching S/N U[S/N String],sp>[Response String] For Non-matching S/N {null}
WC<cr>	Capture Pressure	{null}

Notations:

<> indicates a single ascii character

[] indicates an ascii string

{ } text within the braces describes the response (this is essentially a comment)

"" text within quotes represents a literal ascii text string

Definitions:

Term	Name	Description
<cr>	Carriage Return	ascii Carriage Return. This is a command/response delimiter
<sp>	Space	ascii Space Character
[Accuracy String]	Accuracy String	Part accuracy string. Given in % full scale output. Example: 0.250 %FSO Notes: 1.) There is a space between the numeric accuracy "0.250" and units "%FSO." 2.) FSO stands for Full Scale Output (full scale output is determined by the Pressure Range String.)
[hhhh]	High Resolution Output	This is a four character ascii string representing a hexadecimal value. Example: 3F7C Represents an output count of 16,252 Note: the output is forced to "8000" upon an error. except error bit 8, see error bit codes.
[llll]	Low Resolution Output	This is a four character ascii string representing a hexadecimal value. Example: 1D58 Represents an output count of 7,512 Note: the output is forced to "8000" upon an error. except error bit 8, see error bit codes.
[Model String]	Model String	Part Model as given in the data sheet (also order number.) The general model syntax is [Full Scale Pressure]<sp>[Pressure Units]-[Pressure Model]-DO Example: 100 PSI-D-DO Where: Full Scale Pressure=100 Pressure Units=PSI (inH2O, mbar or mmHg available) DO represents Digital Output Notes: 1.) Exception to this syntax is the Barometer. 2.) Custom models may be different.

Definitions:

Term	Name	Description																										
[Pressure Range String]	Pressure Range String	This is the compensated pressure range of the part. Syntax: [low limit]<sp>"to"<sp>[high limit]<sp>[units][mode] Example: 20 to 32 mmHgA Where: Low limit = 20 High limit = 32 Units = mmHg Mode = A (absolute pressure) (D differential and G gage pressure also available.)																										
[Response String]	A Fully Formed Response String	Example: "RL=1E43<sp>0000<cr>																										
[S/N String]	Serial Number String	<p>YMDD-NN-BSPP (12 character String) Where: Y : Year (0~9) M : Month (A~M, excluding I) DD: Day of Month NN: Lot (lot sequence for a given day) B : Lot Batch# (A~Z) S : Test Oven Slot# (1~5) P : Position on Slot (1~15) Example: 3D23-03-A103</p> <p>April 23, 2003 3rd lot of the day Batch A, Slot 1, Position 03 This allows traceability to original test data</p> <table border="1" style="float: right; margin-left: 20px;"> <thead> <tr> <th colspan="2">Month Codes</th> </tr> </thead> <tbody> <tr><td>January</td><td>: A</td></tr> <tr><td>February</td><td>: B</td></tr> <tr><td>March</td><td>: C</td></tr> <tr><td>April</td><td>: D</td></tr> <tr><td>May</td><td>: E</td></tr> <tr><td>June</td><td>: F</td></tr> <tr><td>July</td><td>: G</td></tr> <tr><td>August</td><td>: H</td></tr> <tr><td>September</td><td>: J</td></tr> <tr><td>October</td><td>: K</td></tr> <tr><td>November</td><td>: L</td></tr> <tr><td>December</td><td>: M</td></tr> </tbody> </table>	Month Codes		January	: A	February	: B	March	: C	April	: D	May	: E	June	: F	July	: G	August	: H	September	: J	October	: K	November	: L	December	: M
Month Codes																												
January	: A																											
February	: B																											
March	: C																											
April	: D																											
May	: E																											
June	: F																											
July	: G																											
August	: H																											
September	: J																											
October	: K																											
November	: L																											
December	: M																											
[Temperature Range String]	Temperature Range String	This is the compensated temperature range of the part. Syntax: [low limit]<sp>[high limit]<sp>"C" Example: -20 to 85 C -40 to 125 C and custom ranges also available.																										
[eeee]	Error Codes	<p>The error codes are bits packed within a double byte. The four character string is an ascii hex expression. The error code bits are: Bit 0 : Part not factory compensated Bit 1 : Tdex Overflow Bit 2 : Tdex Over-range Bit 3 : Pdex Overflow Bit 4 : Pdex Over-range Bit 5 : PWL Overflow Bit 6 : Scale Overflow Bit 7 : High Resolution Overflow Bit 8 : Pressure Output Limited to Specific Value Bits 9 through 15 : Reserved</p> <p>Example: 0100 Represents erro bit 8 set and the Pressure Output Limited</p> <p>Notes: Bit 0 : This should not appear if the part has been calibrated Bits 1 thru 7 : indicate computational error when compensated Bit 8 : indicates that the pressure applied to the part exceeds the range of the part and is limit to either the high or low limit</p>																										
{null}	Null Response	No response from the part. In the event of a serial number mismatch the part will not respond (to avoid buss contention.)																										

All Sensors reserves the right to make changes to any products herein. All Sensors does not assume any liability arising out of the application or use of any product or circuit described herein, neither does it convey any license under its patent rights nor the rights of others.

© MICROWIRE/PLUS IS A REGISTERED TRADEMARK OF NATIONAL SEMICONDUCTOR.



DIGITAL OUTPUT BAROMETER SENSORS

Enhanced Digital Output Sensors: Extended temperature range

Features

- All Combined Errors Over Temperature Less Than 0.1%, Typical
- Wide -40 to 125°C Compensated Temperature Range
- Electrically Compatible to All Sensors GA142 Series
- Enhanced Dual Serial Interface Mode

Applications

- Medical Instrumentation
- Environmental Controls
- Meteorology

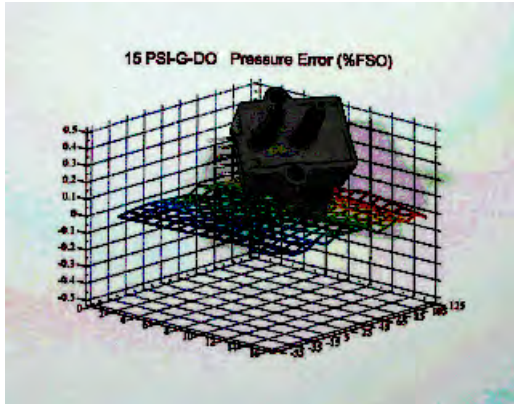

General Description

The Digital Output pressure sensors are based upon a proprietary surface mapping technology to produce a fully digital output that virtually eliminates all repeatable errors over temperature and pressure. This series provides a 12 bit digital serial output (14 bit in High Resolution Mode) with superior offset, span and linearity characteristics. The output is SPI and MICROWIRE/PLUS[®] compatible as well as fully compatible with the All Sensors GA142 Series sensors.

In addition to synchronous communications, the Digital Output pressure sensors incorporates a bi-directional, TTL level, asynchronous serial interfaces mode (hardware selectable 9,600 or 19,200 baud). This mode includes a command set that allows the host to interrogate the sensor for model information, pressure range, serial number, pressure units and conversion factor. The command set also allows the host to select a high resolution output mode, make minor adjustments to offset and has an addressable feature that allows multiple sensors to be tied to the same interface buss.

This series is intended for use with non-corrosive, non-ionic working fluids such as air, dry gases and the like. All signals are 5V TTL/CMOS compatible.

Physical Dimensions

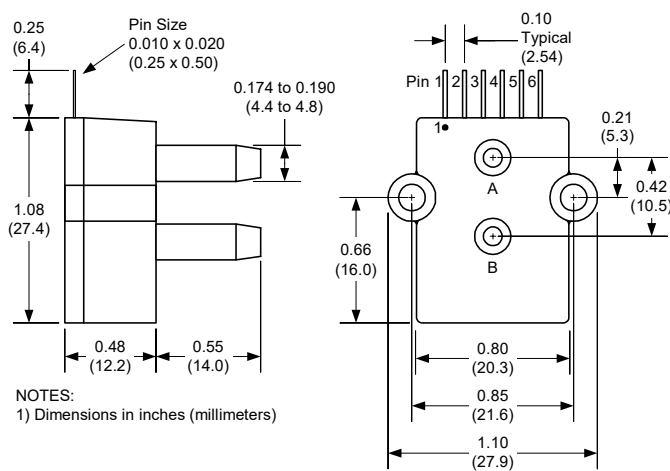

Pin Descriptions

Pin	Label	Description
1	Vcc	+5V power supply input
2	Data/SI	Data output for synchronous mode. Serial in for asynchronous mode.
3	Clock/SO	Clock output for synchronous mode. Serial out for asynchronous mode.
4	Ready/Mode	Ready output for synchronous mode. Selects asynchronous mode when held low during reset.
5	Convert/BR	Convert input for synchronous mode. Selects one of two baud rates for asynchronous mode (low=9,600, high=19,200).
6	Ground	Ground for power and signals

Pressure Applied to Port B



Absolute Maximum Ratings

Supply Voltage (Vcc)	7Vdc
Voltage on Any Pin with Respect to Gnd	-0.6 to Vcc+0.6V
Lead Temperature (soldering 2-4 sec.)	250°C

Environmental Specifications

Operating Voltage	+4.75Vdc to +5.25Vdc
Compensated Temperature	-40°C to +125°C
Operating Temperature	-40 to +125°C
Storage Temperature	-40 to 150°C
Humidity Limits	0 to 95% RH (non condensing)

Standard Pressure Ranges

Part Number	Operating Pressure	Units	Digital Span ⁽⁴⁾	Proof Pressure	Burst Pressure
BARO-DO-MIL	600 to 1100	mBar	3	60 PSI	120 PSI
BARO-INHG-DO-MIL	20 to 32	inches Hg	3	60 PSI	120 PSI
BARO-DO-MIL-PCB	600 to 1100	mBar	3	60 PSI	120 PSI
BARO-INHG-DO-MIL-PCB	20 to 32	inches Hg	3	60 PSI	120 PSI

General Performance Characteristics

Parameter ⁽¹⁾	Minimum	Nominal	Maximum	Units
Resolution	12	--	--	Bit
Conversion Speed	--	8	16	mS
Supply Current	--	8	12	mA
Overall Accuracy ⁽⁵⁾	--	1.0	2.5	mBar
Long Term Drift (one year)	--	--	2.0	mBar

Specification Notes

NOTE 1: UNLESS OTHERWISE SPECIFIED, ALL PARAMETERS ARE MEASURED AT 5.0 VOLT SUPPLY, POSITIVE PRESSURE APPLIED TO PORT B.

NOTE 2: THE DIGITAL OUTPUT IS A 16 BIT SIGNED BINARY OUTPUT IN A TWO'S COMPLEMENT FORMAT. THE APPLIED PRESSURE IS COMPUTED USING THE PRESSURE CONVERSION TABLE (BELOW). THE MODE COLUMN IDENTIFIES THE RESOLUTION OPERATING MODE OF THE DEVICE (A = STANDARD RESOLUTION, B = HIGH RESOLUTION). FSO AND UNITS ARE SHOWN FOR EACH MODEL.

NOTE 3: SHIFT IS WITHIN THE FIRST HOUR OF EXCITATION APPLIED TO THE DEVICE.

NOTE 4: DIGITAL SPAN IS DEPENDENT ON THE RESOLUTION OPERATING MODE. REFER TO THE DIGITAL SPAN TABLE (BELOW) TO IDENTIFY THE DIGITAL SPAN OF THE SPECIFIC MODEL. IN THE EVENT OF AN OVER-PRESSURE OR UNDER-PRESSURE CONDITION, THE DIGITAL OUTPUT WILL ONE COUNT HIGHER OR ONE COUNT LOWER (RESPECTIVELY) TO THE LISTED DIGITAL SPAN TO INDICATE THE CONDITION.

NOTE 5: OVERALL ACCURACY INCLUDES THE COMBINED EFFECTS OF OFFSET AND SPAN SHIFTS OVER TEMPERATURE, LINEARITY, HYSTERESIS, AND OFFSET AND SPAN CALIBRATION.

Error Code Table (Asynchronous mode)

Bit 0 : Part not compensated
Bit 1 : Tdex Overflow
Bit 2 : Tdex Over-range
Bit 3 : Pdex Overflow
Bit 4 : Pdex Over-range
Bit 5 : PWL Overflow
Bit 6 : Scaling Overflow
Bit 7 : High resolution overflow
Bit 8 : Pressure Output Limited to Specified Value
Bit 9 through Bit 15 : Reserved

Pressure Conversion Table

Mode	Pressure Output Equation
S	$P_{out} = \text{Digital Output} \times \frac{FSO \times \text{Units}}{10,000}$
H	$P_{out} = \text{Digital Output} \times \frac{FSO \times \text{Units}}{32,767}$

Digital Span Table

Span	Mode S (Standard)	Mode H (High Res)
1	-10,399 to 10,399	-32,767 to 32,766
2	-399 to 10,399	-999 to 32,766
3	5,054 to 10,399	17,501 to 32,766

Option: PCB mounted compatible to GA-series and SMRT series

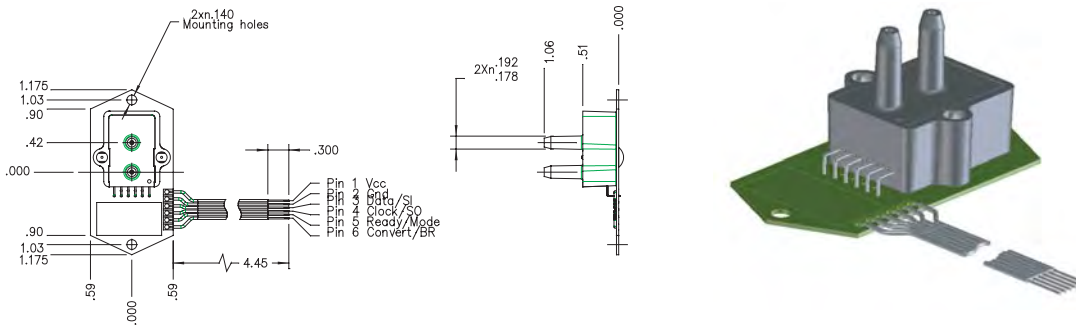

Optional 90 degree lead bend

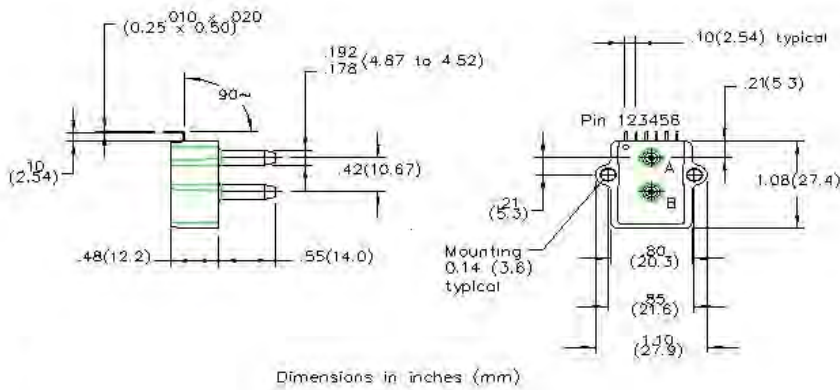

Typical Configurations

Synchronous Communications

Typical synchronous communications configuration (compatible with All Sensors GA142 Series Digital Output Sensors).

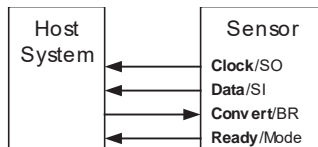

Asynchronous Communications

Typical asynchronous communications configuration. The Mode pin is interrogated at power up and if tied low, will cause the sensor to enter asynchronous communications mode. This mode supports multiple sensors by addressable commands. The Convert/BR pin then serves to select one of two available baud rates.

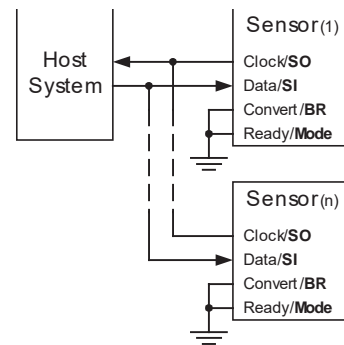

Asynchronous Command Summary ^(1,2)

Command	Description	Response
RD	Read Mode Setting	RD=<Mode>
RM	Read Model Information	RM=<Model String>
RO	Read User Offset Setting	RO=<hhhh>
RP	Read Pressure	RP=<hhhh>
RR	Read Device Pressure Range	RR=<Range String>
RS	Read Serial Number	RS=<Serial Number String>
WD<Mode>	Write Mode Setting ("S" = Standard, "H" = High Resolution)	WD=<Mode>
WO<Offset>	Write User Offset Setting	WO=<hhhh>
U<S/N><Cmd>	Select Unique Part for following command (for multidrop configurations).	U<S/N><Cmd>

Asynchronous Command Notes

NOTE 1: ALL COMMANDS AND RESPONSES ARE IN ASCII CHARACTER FORMAT AND ARE TERMINATED BY A CARRIAGE RETURN (CARRIAGE RETURNS ARE NOT SHOWN IN COMMAND AND RESPONSE TABLE). EXAMPLE: THE READ HIGH RESOLUTION PRESSURE COMMAND (REPRESENTED BY: RH<CR>) IS GIVEN BY THE FOLLOWING THREE BYTE SEQUENCE: 0x52 0x48 0x0D

NOTE 2: <hhhh> IS A FOUR BYTE ASCII STRING REPRESENTING A 16-BIT SIGNED VALUE. EXAMPLE: RH=2B7D REPRESENTS THE RESPONSE OF AN RH COMMAND WITH THE PRESSURE OUTPUT OF 0x2B7D (11,133 DECIMAL) VALUE.

NOTE 3: <LLLL> IS A FOUR BYTE ASCII STRING REPRESENTING THE LOW RESOLUTION OUTPUT (SIMILAR TO THE HIGH RESOLUTION RESPONSE OF NOTE 2)

NOTE 4: <eeee> IS A 16-BIT ERROR CODE. THE REPRESENTATION IS FOUR BYTE ASCII STRING (EXPRESSING A DOUBLE-BYTE OR 16-BITS). A "NO ERROR" CONDITION IS EXPRESSED AS "0000" WHERE AN ERROR IS EXPRESSED BY SETTING AN INDIVIDUAL BIT OF THE ERROR WORD AND PRESENTING IT IN ASCII HEX FORMAT.

NOTE 5: {NULL} IS A NULL RESPONSE (NO RESPONSE). THE INTENT UTILITY OF THE COMMAND IS TO APPLY THIS COMMAND IN A MULTIDROP CONFIGURATION (BUSSED CONFIGURATION) AND SIMULTANEOUSLY CAPTURE THE PRESSURE OF ALL OF THE DEVICES ON THE BUSS. THE CAPTURED READINGS CAN SUBSEQUENTLY BE READ USING THE U COMMAND (SELECT UNIQUE PART) IN CONJUNCTION WITH THE RC COMMAND. EXAMPLE: U<S/N>RC<CR>

All Sensors reserves the right to make changes to any products herein. All Sensors does not assume any liability arising out of the application or use of any product or circuit described herein, neither does it convey any license under its patent rights nor the rights of others.

® MICROWIRE/PLUS IS A REGISTERED TRADEMARK OF NATIONAL SEMICONDUCTOR.

Amplified Output

ADCA SERIES AMPLIFIED LOW PRESSURE SENSORS

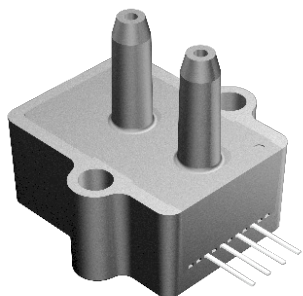

Features

- 0.25 to 60 In H₂O Pressure Ranges
- Ratiometric 4V Amplified Output
- Temperature Compensated Ranges Available in Standard, Industrial and Military ranges.
- Calibrated Zero and Span

Applications

- Medical Instrumentation
- Environmental Controls
- HVAC

General Description

The ADCA series of Amplified low pressure sensors are based upon a proprietary technology to reduce all output offset or common mode errors. This model provides a ratiometric 4-volt output with superior output offset characteristics. Output offset errors due to change in temperature, stability to warm-up, stability to long time period, and position sensitivity are all significantly reduced when compared to conventional compensation methods. In addition the sensor utilizes a silicon, micromachined, stress concentration enhanced structure to provide a very linear output to measured pressure.

These calibrated and temperature compensated sensors give an accurate and stable output over a wide temperature range. This series is intended for use with non-corrosive, non-ionic working fluids such as air, dry gases and the like.

The output of the device is ratiometric to the supply voltage over a supply voltage range of 4.5 to 5.5 volts.

Physical Dimensions

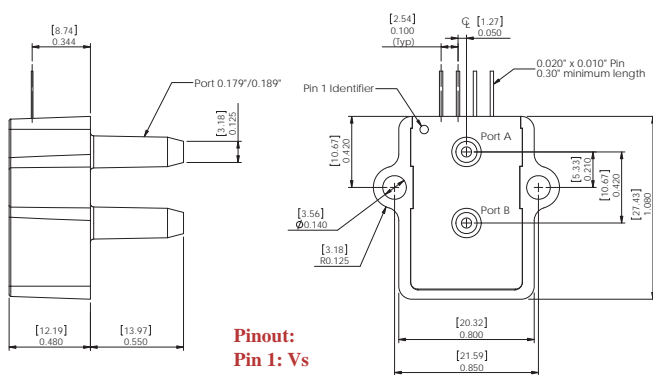

Pinout:
Pin 1: Vs
Pin 2: Gnd
Pin 3: Vout
Pin 4: Do Not Connect

Equivalent Circuit

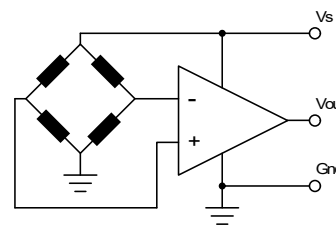

Pressure Sensor Ratings

Supply Voltage VS	+4.5 to +5.5 Vdc
Common-mode pressure	-10 to +10 psig
Lead Temperature, max (soldering 2-4 sec.)	270°C

Standard Pressure Ranges

Environmental Specifications

Temperature Ranges	
Compensated	Standard: 5° C to 50° C Industrial: -25° C to 85° C Military: -40° C to 125° C
Operating & Storage	-40 to 125° C
Humidity Limits	0 to 95% RH (non condensing)

Device	Operating Range ^{A, B}		Pressure Type	Nominal Span	Proof Pressure		Burst Pressure		Specification Notes
	inH2O	Pa			inH2O	kPa	inH2O	kPa	
0.25 INCH-D-4V	±0.25	65	Differential	4V	40	10	80	20	1
0.25 INCH-G-4V	0 to 0.25	65	Gage	4V	40	10	80	20	1
0.5 INCH-D-4V	±0.5	125	Differential	4V	40	10	80	20	1
0.5 INCH-G-4V	0 to 0.5	125	Gage	4V	40	10	80	20	1
1 MBar-D-4V	±1 mbar	100	Differential	4V	100	25	200	50	1
1 INCH-D-4V	±1	250	Differential	4V	100	25	200	50	-
1 INCH-G-4V	0 to 1	250	Gage	4V	100	25	200	50	-
2.5 INCH-D-4V	±2.5	625	Differential	4V	200	50	300	75	1
2.5 INCH-G-4V	0 to 2.5	625	Gage	4V	200	50	300	75	1
5 INCH-D-4V	±5	1,250	Differential	4V	200	50	300	75	-
5 INCH-G-4V	0 to 5	1,250	Gage	4V	200	50	300	75	-
10 INCH-D-4V	±10	2,500	Differential	4V	200	50	300	75	-
10 INCH-G-4V	0 to 10	2,500	Gage	4V	200	50	300	75	-
20 INCH-D-4V	±20	5,000	Differential	4V	300	75	500	125	-
20 INCH-G-4V	0 to 20	5,000	Gage	4V	300	75	500	125	-
30 INCH-D-4V	±30	7,500	Differential	4V	500	125	800	200	-
30 INCH-G-4V	0 to 30	7,500	Gage	4V	500	125	800	200	-
40 INCH-G-4V	0 to 40	10,000	Gage	4V	500	125	800	200	1
60 INCH-G-4V	0 to 60	15,000	Gage	4V	500	125	800	200	1

Note A: Operating range in Pa is expressed as an approximate value.

Note B: Products are calibrated to operating range expressed in inH2O (except 1 MBar-D-4V, which is calibrated to range in mbar).

Ordering Information:

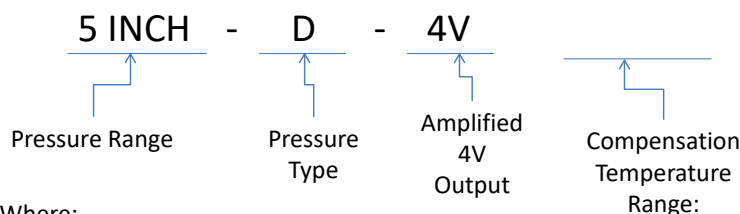

Where:

Compensation Temperature Range: _____ (empty – indicates Standard)

Compensation Temperature Range: “—PRIME” indicates Industrial

Compensation Temperature Range: “—MIL” indicates Military

Example: 5 INCH-D-4V-PRIME

Performance Characteristics for ADCA Series Amplified Low Pressure Sensors

All parameters are measured at 5.0 volt excitation and room temperature unless otherwise specified. Pressure measurements are with positive pressure applied to PORT B

Parameter	Minimum	Nominal	Maximum	Units	Specification Notes
Output Span					
All Differential Products	±1.90	±2.0	±2.10	V	5
All Gage Products	3.9	4.0	4.1	V	5
Span Temperature Shift					
0.25 INCH-D-4V	-	-	±3	%FSS	2
0.25 INCH-G-4V	-	-	±3	%FSS	2
0.50 INCH-D-4V	-	-	±3	%FSS	2
0.50 INCH-G-4V	-	-	±3	%FSS	2
1 MBAR-D-4V	-	-	±3	%FSS	2
1 INCH-D-4V	-	-	±2	%FSS	2
1 INCH-G-4V	-	-	±2	%FSS	2
2.5 INCH-D-4V	-	-	±2	%FSS	2
2.5 INCH-G-4V	-	-	±2	%FSS	2
All Others	-	-	±1	%FSS	2
Offset Voltage @ zero differential pressure					
All Differential Products	2.15	2.25	2.35	V	-
All Gage Products	0.15	0.25	0.35	V	-
Offset Temperature Shift					
0.25 INCH-D-4V	-	-	±60	mV	2
0.25 INCH-G-4V	-	-	±60	mV	2
0.50 INCH-D-4V	-	-	±60	mV	2
0.50 INCH-G-4V	-	-	±60	mV	2
1 MBAR-D-4V	-	-	±60	mV	2
1 INCH-D-4V	-	-	±60	mV	2
1 INCH-G-4V	-	-	±60	mV	2
2.5 INCH-D-4V	-	-	±60	mV	2
2.5 INCH-G-4V	-	-	±60	mV	2
5 INCH-D-4V	-	-	±40	mV	2
5 INCH-G-4V	-	-	±40	mV	2
All Others	-	-	±20	mV	2
Offset Warm-up Shift					
0.25 INCH-D-4V	-	±20	-	mV	3
0.25 INCH-G-4V	-	±20	-	mV	3
0.50 INCH-D-4V	-	±20	-	mV	3
0.50 INCH-G-4V	-	±20	-	mV	3
1 MBAR-D-4V	-	±20	-	mV	3
1 INCH-D-4V	-	±10	-	mV	3
1 INCH-G-4V	-	±10	-	mV	3
All Others	-	±5	-	mV	3
Offset Position Sensitivity (±1g)					
0.25 INCH-D-4V	-	±20	-	mV	6
0.25 INCH-G-4V	-	±20	-	mV	6
0.50 INCH-D-4V	-	±20	-	mV	6
0.50 INCH-G-4V	-	±20	-	mV	6
1 MBAR-D-4V	-	±20	-	mV	6
1 INCH-G-4V	-	±15	-	mV	6
All Others	-	±5	-	mV	6

Performance Characteristics for ADCA Series Amplified Low Pressure Sensors (Cont'd)

All parameters are measured at 5.0 volt excitation and room temperature unless otherwise specified. Pressure measurements are with positive pressure applied to PORT B

Parameter		Minimum	Nominal	Maximum	Units	Specification Notes
Offset Long Term Drift (one year)						
	0.25 INCH-D-4V	-	±20	-	mV	-
	0.25 INCH-G-4V	-	±20	-	mV	-
	0.50 INCH-D-4V	-	±20	-	mV	-
	0.50 INCH-G-4V	-	±20	-	mV	-
	1 MBAR-D-4V	-	±20	-	mV	-
	1 INCH-D-4V	-	±10	-	mV	-
	1 INCH-G-4V	-	±10	-	mV	-
	All Others	-	±5	-	mV	-
Linearity, Hysteresis error (all products)						
		-	0.05	0.25	%FSS	4

Pressure Response: for any pressure applied the response time to get to 90% of pressure applied is typically less than 500 useconds.

Specification Notes

Note 1: Part number is available in Standard Compensation Temperature Range only.

Note 2: Shift is relative to 25°C between standard, industrial, or military compensated temperature range endpoints.

Note 3: Shift is within the first hour of excitation applied to the device.

Note 4: Measured at one-half full scale rated pressure using best straight line curve fit.

Note 5: The span is the algebraic difference between full scale output voltage and the offset voltage.

Note 6: Parameter is characterized and not 100% tested.

All Sensors reserves the right to make changes to any products herein. All Sensors does not assume any liability arising out of the application or use of any product or circuit described herein, neither does it convey any license under its patent rights nor the rights of others.

Amplified Middle Pressure Sensors

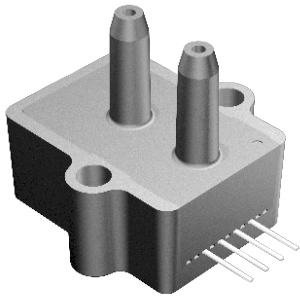

Features

- 0 to ± 0.3 to 0 to 150 psi Pressure Ranges
- Ratiometric 4V Output
- Temperature Compensated
- Calibrated Zero and Span

Applications

- Medical Instrumentation
- Environmental Instrumentation
- HVAC Instrumentation

General Description

The Amplified line of middle pressure sensors are based upon a proprietary package technology to reduce errors. This model provides a ratiometric 4-volt output with superior output characteristics. The sensor housing has been designed specifically to reduce package induced parasitic stress and strain. In addition the sensor utilizes a silicon, micromachined, stress concentration enhanced structure to provide a very linear output to measured pressure.

These calibrated and temperature compensated sensors give an accurate and stable output over a wide temperature range. Each sensor is internally compensated using an ASIC compensation technique. This series is intended for use with non-corrosive, non-ionic working fluids such as air, dry gases and the like.

The output of the device is ratiometric to the supply voltage over a supply voltage range of 4.5 to 5.5 volts.

Physical Dimensions

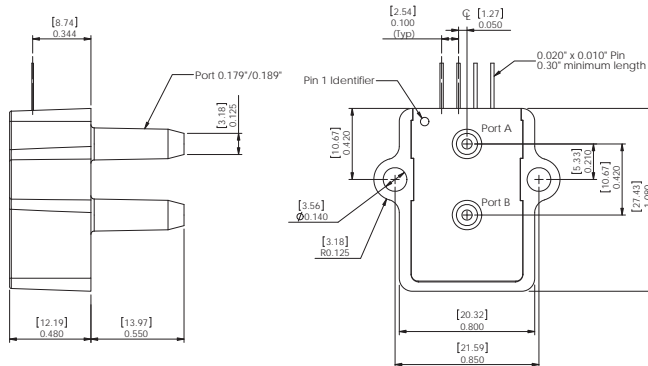

Equivalent Circuit

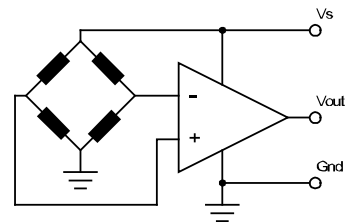

- pin 1: Vsupply
- pin 2: Common
- pin 3: Voutput
- pin 4: do not connect

Approvals

MKT	DATE	MFG	DATE	ENG	DATE	QA	DATE
<input type="checkbox"/> As Is <input type="checkbox"/> With Change		<input type="checkbox"/> As Is <input type="checkbox"/> With Change		<input type="checkbox"/> As Is <input type="checkbox"/> With Change		<input type="checkbox"/> As Is <input type="checkbox"/> With Change	

All Sensors

DS-0028 Rev D

Pressure Sensor Ratings

Supply Voltage, Vs	+4.5 to +5.5 Vdc
Common-mode pressure	-10 to +10 psig
Lead Temperature, max (soldering 2-4 sec.)	250°C

Environmental Specifications

Temperature Ranges	
Compensated	5 to 50° C
Operating	-25 to 85° C
Storage	-40 to 125° C
Humidity Limits	0 to 95% RH (non condensing)

Standard Pressure Ranges

Part Number	Operating Pressure	Nominal Span	Proof Pressure	Burst Pressure
0.3 PSI-D-4V	±0.3 PSI	±2 V	5 PSI	10 PSI
0.3 PSI-G-4V	0 - 0.3 PSI	4 V	5 PSI	10 PSI
1 PSI-D-4V	±1 PSI	±2 V	5 PSI	10 PSI
1 PSI-G-4V	0 - 1 PSI	4 V	5 PSI	10 PSI
2.5 PSI-D-4V	±2.5 PSI	±2 V	10 PSI	20 PSI
2.5 PSI-G-4V	0 - 2.5 PSI	4V	10 PSI	20 PSI
5 PSI-D-4V	± 5 PSI	±2 V	15 PSI	30 PSI
5 PSI-G-4V	0 - 5 PSI	4 V	15 PSI	30 PSI
15 PSI-A-4V	0 - 15 PSIA	4 V	45 PSI	60 PSI
15 PSI-D-4V	±15 PSI	±2 V	45 PSI	60 PSI
15 PSI-G-4V	0 - 15 PSI	4 V	45 PSI	60 PSI
30 PSI-A-4V	0 - 30 PSIA	4 V	60 PSI	60 PSI
30 PSI-D-4V	±30 PSI	±2 V	60 PSI	60 PSI
30 PSI-G-4V	0 - 30 PSI	4 V	60 PSI	100 PSI
100 PSI-A-4V	0 - 100 PSI	4V	150 PSI	150 PSI
100 PSI-D-4V	±100 PSI	±2 V	150 PSI	150 PSI
100 PSI-G-4V	0 - 100 PSI	4V	150 PSI	150 PSI
150 PSI-D-4V	±150 PSI	±2 V	200 PSI	200 PSI
150 PSI-G-4V	0 - 150 PSI	4V	200 PSI	200 PSI
BARO-A-4V	600 - 1100 mbarA	4V	45 PSI	60 PSI

Performance Characteristics for 0.3 PSI-D-4V

Parameter, note 1	Minimum	Nominal	Maximum	Units
Output Span, note 4 (FSS)	±1.90	±2.0	±2.10	V
Offset Voltage @ zero differential pressure	2.15	2.25	2.35	V
Offset Temperature Shift, note 2	--	--	±40.0	mV
Linearity, hysteresis error, note 3	--	--	±0.5	%FSS
Span Temperature Shift, note 2	--	--	±2.0	%FSS

Amplified Output Medium Pressure Sensor

Performance Characteristics for: 2.5 PSI-G-4V

Parameter, NOTE 1	Minimum	Nominal	Maximum	Units
Output Span, NOTE 4 (FSS)	3.90	4.0	4.10	V
Offset Voltage @ zero gage pressure	0.15	0.25	0.35	V
Offset Temperature Shift, note 2	--	--	±20.0	mV
Linearity, hysteresis error, note 3	--	--	±0.5	%FSS
Span Temperature Shift, note 2	--	--	±1.0	%FSS

Performance Characteristics for: 5 PSI-D-4V

Parameter, NOTE 1	Minimum	Nominal	Maximum	Units
Output Span, NOTE 4 (FSS)	±1.90	±2.0	±2.10	V
Offset Voltage @ zero differential pressure	2.15	2.25	2.35	V
Offset Temperature Shift, note 2	--	--	±20.0	mV
Linearity, hysteresis error, note 3	--	--	±0.5	%FSS
Span Temperature Shift, note 2	--	--	±1.0	%FSS

Performance Characteristics for: 5 PSI-G-4V

Parameter, NOTE 1	Minimum	Nominal	Maximum	Units
Output Span, NOTE 4 (FSS)	3.90	4.0	4.10	V
Offset Voltage @ zero gage pressure	0.15	0.25	0.35	V
Offset Temperature Shift, note 2	--	--	±20.0	mV
Linearity, hysteresis error, note 3	--	--	0.5	%FSS
Span Temperature Shift, note 2	--	--	±1.0	%FSS

Performance Characteristics for 15 PSI-A-4V

Parameter, note 1	Minimum	Nominal	Maximum	Units
Output Span, note 4 (FSS)	3.90	4.0	4.10	V
Offset Voltage @ zero absolute pressure	0.15	0.25	0.35	V
Offset Temperature Shift, note 2	--	--	±20.0	mV
Linearity, hysteresis error, note 3	--	--	±0.5	%FSS
Span Temperature Shift, note 2	--	--	±1.0	%FSS

Amplified Output Medium Pressure Sensor

Performance Characteristics for 30 PSI-G-4V

Parameter, note 1	Minimum	Nominal	Maximum	Units
Output Span, note 4 (FSS)	3.90	4.0	4.10	V
Offset Voltage @ zero gage pressure	0.15	0.25	0.35	V
Offset Temperature Shift, note 2	--	--	±20.0	mV
Linearity, hysteresis error, note 3	--	--	±0.5	%FSS
Span Temperature Shift, note 2	--	--	±1.0	%FSS

Performance Characteristics for 100 PSI-A-4V

Parameter, note 1	Minimum	Nominal	Maximum	Units
Output Span, note 4 (FSS)	3.90	4.0	4.10	V
Offset Voltage @ zero absolute pressure	0.15	0.25	0.35	V
Offset Temperature Shift, note 2	--	--	±20.0	mV
Linearity, hysteresis error, note 3	--	--	±0.5	%FSS
Span Temperature Shift, note 2	--	--	±1.0	%FSS

Performance Characteristics for 100 PSI-D-4V

Parameter, note 1	Minimum	Nominal	Maximum	Units
Output Span, note 4 (FSS)	±1.90	±2.0	±2.10	V
Offset Voltage @ zero differential pressure	2.15	2.25	2.35	V
Offset Temperature Shift, note 2	--	--	±20.0	mV
Linearity, hysteresis error, note 3	--	--	±0.5	%FSS
Span Temperature Shift, note 2	--	--	±1.0	%FSS

Performance Characteristics for 100 PSI-G-4V

Parameter, note 1	Minimum	Nominal	Maximum	Units
Output Span, note 4 (FSS)	3.90	4.0	4.10	V
Offset Voltage @ zero gage pressure	0.15	0.25	0.35	V
Offset Temperature Shift, note 2	--	--	±20.0	mV
Linearity, hysteresis error, note 3	--	--	±0.5	%FSS
Span Temperature Shift, note 2	--	--	±1.0	%FSS

Amplified Output Medium Pressure Sensor

Performance Characteristics for 150 PSI-D-4V

Parameter, note 1	Minimum	Nominal	Maximum	Units
Output Span, note 4 (FSS)	±1.90	±2.0	±2.10	V
Offset Voltage @ zero differential pressure	2.15	2.25	2.35	V
Offset Temperature Shift, note 2	--	--	±20.0	mV
Linearity, hysteresis error, note 3	--	--	±0.5	%FSS
Span Temperature Shift, note 2	--	--	±1.0	%FSS

Performance Characteristics for 150 PSI-G-4V

Parameter, note 1	Minimum	Nominal	Maximum	Units
Output Span, note 4 (FSS)	3.90	4.0	4.10	V
Offset Voltage @ zero gage pressure	0.15	0.25	0.35	V
Offset Temperature Shift, note 2	--	--	±20.0	mV
Linearity, hysteresis error, note 3	--	--	±0.5	%FSS
Span Temperature Shift, note 2	--	--	±1.0	%FSS

Performance Characteristics for BARO-A-4V

Parameter, note 1	Minimum	Nominal	Maximum	Units
Output Voltage @ 1,100 mbar	4.20	4.25	4.30	V
Output Voltage @ 600 mbar	0.20	0.25	0.30	V
Offset Temperature Shift, note 2	--	--	±20.0	mV
Linearity, hysteresis error, note 3	--	0.05	±0.25	%FSS
Span Temperature Shift, note 2	--	--	±1.0	%FSS

Pressure Response: for any pressure applied the response time to get to 90% of pressure applied is typically less than 500 useconds.

Specification Notes

- NOTE 1: ALL PARAMETERS ARE MEASURED AT 5.0 VOLT EXCITATION, FOR THE NOMINAL FULL SCALE PRESSURE AND ROOM TEMPERATURE UNLESS OTHERWISE SPECIFIED. PRESSURE MEASUREMENTS ARE WITH POSITIVE PRESSURE APPLIED TO PORT B. ABSOLUTE DEVICES REQUIRE PRESSURE TO BE APPLIED TO PORT A.
- NOTE 2: SHIFT IS RELATIVE TO 25°C OVER THE COMPENSATED TEMPERATURE RANGE.
- NOTE 3: MEASURED AT ONE-HALF FULL SCALE RATED PRESSURE USING BEST STRAIGHT LINE CURVE FIT.
- NOTE 4: THE SPAN IS THE ALGEBRAIC DIFFERENCE BETWEEN FULL SCALE OUTPUT VOLTAGE AND THE OFFSET VOLTAGE.

Amplified Middle Pressure Sensors

Industrial Temperature Grade



Features

- 0 to 0.3 psi to 0 to 100 psi Pressure Ranges
- Ratiometric 4V Output
- Temperature Compensated (-25C to 85C)
- Calibrated Zero and Span

Applications

- Medical Instrumentation
- Environmental Controls
- HVAC

General Description

The Amplified line of middle pressure sensors is based upon a proprietary package technology to reduce errors. This model provides a ratiometric 4-volt output with superior output characteristics. The sensor housing has been designed specifically to reduce package induced parasitic stress and strain. In addition the sensor utilizes a silicon, micromachined, stress concentration enhanced structure to provide a very linear output to measured pressure.

These calibrated and temperature compensated sensors give an accurate and stable output over a wide temperature range. Each sensor is internally compensated using an ASIC compensation technique. This series is intended for use with non-corrosive, non-ionic working fluids such as air, dry gases and the like.

The output of the device is ratiometric to the supply voltage over a supply voltage range of 4.5 to 5.5 volts.

Physical Dimensions

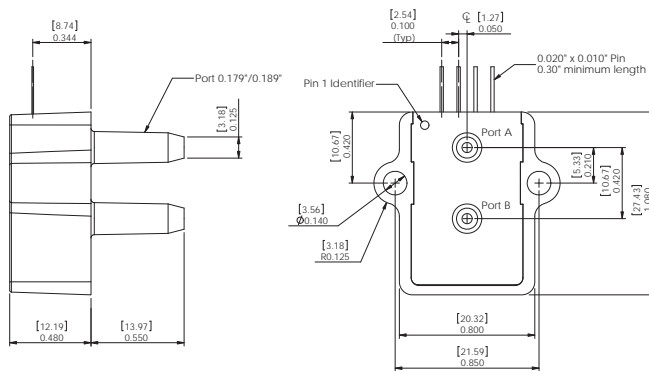

- pin 1: Vs
- pin 2: Gnd
- pin 3: Vout
- pin 4: do not connect

Approvals

MKT	DATE	MFG	DATE	ENG	DATE	QA	DATE
<input type="checkbox"/> As Is <input type="checkbox"/> With Change		<input type="checkbox"/> As Is <input type="checkbox"/> With Change		<input type="checkbox"/> As Is <input type="checkbox"/> With Change		<input type="checkbox"/> As Is <input type="checkbox"/> With Change	

All Sensors

DS-0029 Rev C

Pressure Sensor Ratings

Supply Voltage VS	+4.5 to +5.5 Vdc
Common-mode pressure	-10 to +10 psig
Lead Temperature, max (soldering 2-4 sec.)	250°C

Environmental Specifications

Temperature Ranges	
Compensated	-25 to 85° C
Operating	-40 to 125° C
Storage	-40 to 125° C
Humidity Limits	0 to 95% RH (non condensing)

Standard Pressure Ranges

Part Number	Operating Pressure	Nominal Span	Proof Pressure	Burst Pressure
0.3 PSI-D-4V-PRIME	±0.3 PSI	4 V	5 PSI	10 PSI
0.3 PSI-G-4V-PRIME	0 - 0.3 PSI	4 V	5 PSI	10 PSI
1 PSI-D-4V-PRIME	±1 PSI	4 V	5 PSI	10 PSI
1 PSI-G-4V-PRIME	0 - 1 PSI	4 V	5 PSI	10 PSI
5 PSI-D-4V-PRIME	± 5 PSI	4 V	15 PSI	30 PSI
5 PSI-G-4V-PRIME	0 - 5 PSI	4 V	15 PSI	30 PSI
15 PSI-A-4V-PRIME	0 - 15 PSIA	4 V	45 PSI	60 PSI
15 PSI-D-4V-PRIME	±15 PSI	4 V	45 PSI	60 PSI
15 PSI-G-4V-PRIME	0 - 15 PSI	4 V	45 PSI	60 PSI
30 PSI-A-4V-PRIME	0 - 30 PSIA	4V	90 PSI	150 PSI
30 PSI-D-4V-PRIME	±30 PSI	4 V	90 PSI	150 PSI
30 PSI-G-4V-PRIME	0 - 30 PSI	4 V	90 PSI	150 PSI
100 PSI-A-4V-PRIME	0 - 100 PSIA	4V	150 PSI	150 PSI
100 PSI-D-4V-PRIME	±100 PSI	4V	150 PSI	150 PSI
100 PSI-G-4V-PRIME	0 - 100 PSI	4V	150 PSI	150 PSI

Performance Characteristics for 0.3 PSI-D-4V-PRIME

Parameter, note 1	Minimum	Nominal	Maximum	Units
Operating Range, differential pressure	--	±0.3	--	PSI
Output Span, note 4	±1.90	±2.0	±2.10	V
Offset Voltage @ zero differential pressure	2.15	2.25	2.35	V
Offset Temperature Shift (-25°C to 85°C), note 2	--	--	±40	mV
Linearity, hysteresis error, note 3	--	--	±0.5	%FSS
Span Shift (-25°C to 85°C), note 2	--	--	±2	%FSS

Amplified Middle Pressure Sensors Industrial Grade

Performance Characteristics for 0.3 PSI-G-4V-PRIME

Parameter, note 1	Minimum	Nominal	Maximum	Units
Operating Range, gage pressure	--	0.3	--	PSI
Output Span, note 4	3.90	4.0	4.10	V
Offset Voltage @ zero pressure	0.15	0.25	0.35	V
Offset Temperature Shift (-25°C to 85°C), note 2	--	--	±40	mV
Linearity, hysteresis error, note 3	--	--	±0.5	%FSS
Span Shift (-25°C to 85°C), note 2	--	--	±2	%FSS

Performance Characteristics for 1 PSI-D-4V-PRIME

Parameter, note 1	Minimum	Nominal	Maximum	Units
Operating Range, differential pressure	--	±1.0	--	PSI
Output Span, note 4	±1.90	±2.0	±2.10	V
Offset Voltage @ zero differential pressure	2.15	2.25	2.35	V
Offset Temperature Shift (-25°C to 85°C), note 2	--	--	±40	mV
Linearity, hysteresis error, note 3	--	--	±0.5	%FSS
Span Shift (-25°C to 85°C), note 2	--	--	±1	%FSS

Performance Characteristics for: 1 PSI-G-4V-PRIME

Parameter, NOTE 1	Minimum	Nominal	Maximum	Units
Operating Range, gage pressure	--	1.0	--	PSI
Output Span, NOTE 4	3.90	4.0	4.10	V
Offset Voltage @ zero pressure	0.15	0.25	0.35	V
Offset Temperature Shift (-25°C to 85°C), note 2	--	--	±40	mV
Linearity, hysteresis error, note 3	--	--	±0.5	%FSS
Span Shift (-25°C to 85°C), note 2	--	--	±1	%FSS

Performance Characteristics for: 5 PSI-D-4V-PRIME

Parameter, NOTE 1	Minimum	Nominal	Maximum	Units
Operating Range, differential pressure	--	±5.0	--	PSI
Output Span, NOTE 4	±1.90	±2.0	±2.10	V
Offset Voltage @ zero differential pressure	2.15	2.25	2.35	V
Offset Temperature Shift (-25°C to 85°C), note 2	--	--	±20	mV
Linearity, hysteresis error, note 3	--	--	±0.5	%FSS
Span Shift (-25°C to 85°C), note 2	--	--	±1	%FSS

All Sensors

DS-0029 Rev C

Performance Characteristics for: 5 PSI-G-4V-PRIME

Parameter, NOTE 1	Minimum	Nominal	Maximum	Units
Operating Range, gage pressure	--	5.0	--	PSI
Output Span, NOTE 4	3.90	4.0	4.10	V
Offset Voltage @ zero pressure	0.15	0.25	0.35	V
Offset Temperature Shift (-25°C to 85°C), note 2	--	--	±20	mV
Linearity, hysteresis error, note 3	--	--	±0.5	%FSS
Span Shift (-25°C to 85°C), note 2	--	--	±1	%FSS

Performance Characteristics for 15 PSI-A-4V-PRIME

Parameter, note 1	Minimum	Nominal	Maximum	Units
Operating Range, absolute pressure	--	15.0	--	PSI
Output Span, note 4	3.90	4.0	4.10	V
Offset Voltage @ zero pressure	0.15	0.25	0.35	V
Offset Temperature Shift (-25°C to 85°C), note 2	--	--	±20	mV
Linearity, hysteresis error, note 3	--	--	±0.5	%FSS
Span Shift (-25°C to 85°C), note 2	--	--	±1	%FSS

Performance Characteristics for 15 PSI-D-4V-PRIME

Parameter, note 1	Minimum	Nominal	Maximum	Units
Operating Range, differential pressure	--	±15.0	--	PSI
Output Span, note 4	±1.90	±2.0	±2.10	V
Offset Voltage @ zero differential pressure	2.15	2.25	2.35	V
Offset Temperature Shift (-25°C to 85°C), note 2	--	--	±20	mV
Linearity, hysteresis error, note 3	--	--	±0.5	%FSS
Span Shift (-25°C to 85°C), note 2	--	--	±1	%FSS

Performance Characteristics for 15 PSI-G-4V-PRIME

Parameter, note 1	Minimum	Nominal	Maximum	Units
Operating Range, gage pressure	--	15.0	--	PSI
Output Span, note 4	3.90	4.0	4.10	V
Offset Voltage @ zero pressure	0.15	0.25	0.35	V
Offset Temperature Shift (-25°C to 85°C), note 2	--	--	±20	mV
Linearity, hysteresis error, note 3	--	--	±0.5	%FSS
Span Shift (-25°C to 85°C), note 2	--	--	±1	%FSS

Amplified Middle Pressure Sensors Industrial Grade

Performance Characteristics for 30 PSI-A-4V-PRIME

Parameter, note 1	Minimum	Nominal	Maximum	Units
Operating Range, absolute pressure	--	30.0	--	PSI
Output Span, note 4	3.90	4.0	4.10	V
Offset Voltage @ zero pressure	0.15	0.25	0.35	V
Offset Temperature Shift (-25°C to 85°C), note 2	--	--	±20	mV
Linearity, hysteresis error, note 3	--	--	±0.5	%FSS
Span Shift (-25°C to 85°C), note 2	--	--	±1	%FSS

Performance Characteristics for 30 PSI-D-4V-PRIME

Parameter, note 1	Minimum	Nominal	Maximum	Units
Operating Range, differential pressure	--	±30.0	--	PSI
Output Span, note 4	±1.90	±2.0	±2.10	V
Offset Voltage @ zero differential pressure	2.15	2.25	2.35	V
Offset Temperature Shift (-25°C to 85°C), note 2	--	--	±20	mV
Linearity, hysteresis error, note 3	--	--	±0.5	%FSS
Span Shift (-25°C to 85°C), note 2	--	--	±1	%FSS

Performance Characteristics for 30 PSI-G-4V-PRIME

Parameter, note 1	Minimum	Nominal	Maximum	Units
Operating Range, gage pressure	--	30.0	--	PSI
Output Span, note 4	3.90	4.0	4.10	V
Offset Voltage @ zero pressure	0.15	0.25	0.35	V
Offset Temperature Shift (-25°C to 85°C), note 2	--	--	±20	mV
Linearity, hysteresis error, note 3	--	--	±0.5	%FSS
Span Shift (-25°C to 85°C), note 2	--	--	±1	%FSS

Performance Characteristics for 100 PSI-A-4V-PRIME

Parameter, note 1	Minimum	Nominal	Maximum	Units
Operating Range, absolute pressure	--	100.0	--	PSI
Output Span, note 4	3.90	4.0	4.10	V
Offset Voltage @ zero pressure	0.15	0.25	0.35	V
Offset Temperature Shift (-25°C to 85°C), note 2	--	--	±20	mV
Linearity, hysteresis error, note 3	--	--	±0.5	%FSS
Span Shift (-25°C to 85°C), note 2	--	--	±1	%FSS

Performance Characteristics for 100 PSI-D-4V-PRIME

Parameter, note 1	Minimum	Nominal	Maximum	Units
Operating Range, differential pressure	--	100	--	PSI
Output Span, note 4	±1.90	±2.0	±2.10	V
Offset Voltage @ zero differential pressure	0.15	0.25	0.35	V
Offset Temperature Shift (-25°C to 85°C), note 2	--	--	±20	mV
Linearity, hysteresis error, note 3	--	--	±0.5	%FSS
Span Shift (-25°C to 85°C), note 2	--	--	±1	%FSS

Performance Characteristics for 100 PSI-G-4V-PRIME

Parameter, note 1	Minimum	Nominal	Maximum	Units
Operating Range, gage pressure	--	100	--	PSI
Output Span, note 4	3.90	4.0	4.10	V
Offset Voltage @ zero pressure	0.15	0.25	0.35	V
Offset Temperature Shift (-25°C to 85°C), note 2	--	--	±20	mV
Linearity, hysteresis error, note 3	--	--	±0.5	%FSS
Span Shift (-25°C to 85°C), note 2	--	--	±1	%FSS

Pressure Response: for any pressure applied the response time to get to 90% of pressure applied is typically less than 500 useconds.
Specification Notes

- NOTE 1: ALL PARAMETERS ARE MEASURED AT 5.0 VOLT EXCITATION, FOR THE NOMINAL FULL SCALE PRESSURE AND ROOM TEMPERATURE UNLESS OTHERWISE SPECIFIED. PRESSURE MEASUREMENTS ARE WITH POSITIVE PRESSURE APPLIED TO PORT B. ABSOLUTE DEVICES REQUIRE PRESSURE TO BE APPLIED TO PORT A.
- NOTE 2: SHIFT IS RELATIVE TO 25°C.
- NOTE 3: MEASURED AT ONE-HALF FULL SCALE RATED PRESSURE USING BEST STRAIGHT LINE CURVE FIT.
- NOTE 4: THE SPAN IS THE ALGEBRAIC DIFFERENCE BETWEEN FULL SCALE OUTPUT VOLTAGE AND THE OFFSET VOLTAGE

All Sensors reserves the right to make changes to any products herein. All Sensors does not assume any liability arising out of the application or use of any product or circuit described herein, neither does it convey any license under its patent rights nor the rights of others.

Equivalent Circuit

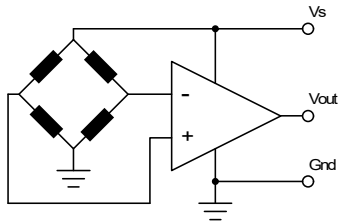

Amplified Middle Pressure Sensors Industrial Grade

Amplified Middle Pressure Sensors

0.3 psi to 15 psi Pressure Sensors

Military Temperature Grade

Features

- 0 to 0.3 psi to 0 to 15 psi Pressure Ranges
- Ratiometric 4V Output
- Temperature Compensated (-40C to 125C)
- Calibrated Zero and Span

Applications

- Medical Instrumentation
- Environmental Controls
- HVAC



General Description

The Amplified line of middle pressure sensors is based upon a proprietary package technology to reduce errors. This model provides a ratiometric 4-volt output with superior output characteristics. The sensor housing has been designed specifically to reduce package induced parasitic stress and strain. In addition the sensor utilizes a silicon, micromachined, stress concentration enhanced structure to provide a very linear output to measured pressure.

These calibrated and temperature compensated sensors give an accurate and stable output over a wide temperature range. Each sensor is internally compensated using an ASIC compensation technique. This series is intended for use with non-corrosive, non-ionic working fluids such as air, dry gases and the like.

The output of the device is ratiometric to the supply voltage over a supply voltage range of 4.5 to 5.5 volts.

Physical Dimensions

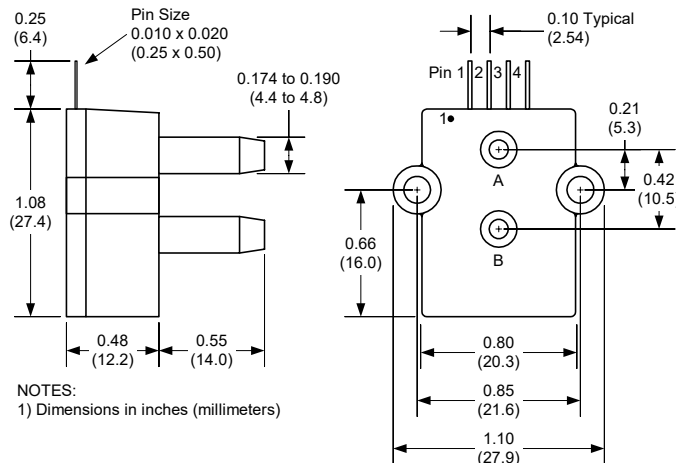

- pin 1: Vsupply
- pin 2: Common
- pin 3: Voutput
- pin 4: do not connect

Pressure Sensor Ratings

Supply Voltage <i>VS</i>	+4.5 to +5.5 Vdc
Common-mode pressure	-10 to +10 psig
Lead Temperature, max (soldering 2-4 sec.)	250°C

Environmental Specifications

Temperature Ranges	
Compensated	-40 to 125° C
Operating	-40 to 125° C
Storage	-40 to 125° C
Humidity Limits	0 to 95% RH (non condensing)

Standard Pressure Ranges

Part Number	Operating Pressure	Nominal Span	Proof Pressure	Burst Pressure
0.3 PSI-D-4V-MIL	±0.3 PSI	4 V	5 PSI	10 PSI
0.3 PSI-G-4V-MIL	0 - 0.3 PSI	4 V	5 PSI	10 PSI
1 PSI-D-4V-MIL	±1 PSI	4 V	5 PSI	10 PSI
1 PSI-G-4V-MIL	0 - 1 PSI	4 V	5 PSI	10 PSI
5 PSI-D-4V-MIL	± 5 PSI	4 V	15 PSI	30 PSI
5 PSI-G-4V-MIL	0 - 5 PSI	4 V	15 PSI	30 PSI
15 PSI-A-4V-MIL	0 - 15 PSIA	4 V	45 PSI	60 PSI
15 PSI-D-4V-MIL	±15 PSI	4 V	45 PSI	60 PSI
15 PSI-G-4V-MIL	0 - 15 PSIG	4 V	45 PSI	60 PSI

Performance Characteristics for 0.3 PSI-D-4V-MIL

Parameter, note 1	Minimum	Nominal	Maximum	Units
Operating Range, differential pressure		±0.3		PSI
Output Span, note 5	±1.90	±2.0	±2.10	volt
Offset Voltage @ zero differential pressure	2.15	2.25	2.35	volt
Offset Temperature Shift (-40°C to 125°C), note 2			±40	mvolt
Linearity, hysteresis error, note 4			±0.5	%fs
Span Shift (-40°C to 125°C), note 2			±2	%span

Performance Characteristics for 0.3 PSI-G-4V-MIL

Parameter, note 1	Minimum	Nominal	Maximum	Units
Operating Range, gage pressure		0.3		PSI
Output Span, note 5	3.90	4.0	4.10	volt
Offset Voltage @ zero pressure	0.15	0.25	0.35	volt
Offset Temperature Shift (-40°C to 125°C), note 2			±40	mvolt
Linearity, hysteresis error, note 4			±0.5	%fs
Span Shift (-40°C to 125°C), note 2			±2	%span

Performance Characteristics for 1 PSI-D-4V-MIL

Parameter, note 1	Minimum	Nominal	Maximum	Units
Operating Range, differential pressure		±1.0		PSI
Output Span, note 5	±1.90	±20	±2.10	volt
Offset Voltage @ zero differential pressure	2.15	2.25	2.35	volt
Offset Temperature Shift (-40°C to 125°C), note 2			±40	mvolt
Linearity, hysteresis error, note 4			±0.5	%fs
Span Shift (-40°C to 125°C), note 2			±1	%span

Performance Characteristics for: 1 PSI-G-4V-MIL

Parameter, NOTE 1	Minimum	Nominal	Maximum	Units
Operating Range, gage pressure		1.0		PSI
Output Span, NOTE 5	3.90	40	4.10	volt
Offset Voltage @ zero pressure	0.15	0.25	0.35	volt
Offset Temperature Shift (-40°C to 125°C), note 2			±40	mvolt
Linearity, hysteresis error, note 4			±0.5	%fs
Span Shift (-40°C to 125°C), note 2			±1	%span

Performance Characteristics for: 5 PSI-D-4V-MIL

Parameter, NOTE 1	Minimum	Nominal	Maximum	Units
Operating Range, differential pressure		±5.0		PSI
Output Span, NOTE 5	±1.90	±2.0	±2.10	volt
Offset Voltage @ zero differential pressure	2.15	2.25	2.35	volt
Offset Temperature Shift (-40°C to 125°C), note 2			±20	mvolt
Linearity, hysteresis error, note 4			±0.5	%fs
Span Shift (-40°C to 125°C), note 2			±1	%span

Performance Characteristics for: 5 PSI-G-4V-MIL

Parameter, NOTE 1	Minimum	Nominal	Maximum	Units
Operating Range, gage pressure		5.0		PSI
Output Span, NOTE 5	3.90	40	4.10	volt
Offset Voltage @ zero pressure	0.15	0.25	0.35	volt
Offset Temperature Shift (-40°C to 125°C), note 2			±20	mvolt
Linearity, hysteresis error, note 4			±0.5	%fs
Span Shift (-40°C to 125°C), note 2			±1	%span



Performance Characteristics for 15 PSI-A-4V-MIL

Parameter, note 1	Minimum	Nominal	Maximum	Units
Operating Range, absolute pressure		15.0		PSI
Output Span, note 5	3.90	4.0	4.10	volt
Offset Voltage @ zero pressure	0.15	0.25	0.35	volt
Offset Temperature Shift (-40°C to 125°C), note 2			±20	mvolt
Linearity, hysteresis error, note 4			±0.5	%fs
Span Shift (-40°C to 125°C), note 2			±1	%span

Performance Characteristics for 15 PSI-D-4V-MIL

Parameter, note 1	Minimum	Nominal	Maximum	Units
Operating Range, differential pressure		±15.0		PSI
Output Span, note 5	±1.90	±2.0	±2.10	volt
Offset Voltage @ zero differential pressure	2.15	2.25	2.35	volt
Offset Temperature Shift (-40°C to 125°C), note 2			±20	mvolt
Linearity, hysteresis error, note 4			±0.5	%fs
Span Shift (-40°C to 125°C), note 2			±1	%span

Performance Characteristics for 15 PSI-G-4V-MIL

Parameter, note 1	Minimum	Nominal	Maximum	Units
Operating Range, gage pressure		15.0		PSI
Output Span, note 5	3.90	4.0	4.10	volt
Offset Voltage @ zero pressure	0.15	0.25	0.35	volt
Offset Temperature Shift (-40°C to 125°C), note 2			±20	mvolt
Linearity, hysteresis error, note 4			±0.5	%fs
Span Shift (-40°C to 125°C), note 2			±1	%span

Equivalent Circuit

Pressure Response: for any pressure applied the response time to get to 90% of pressure applied is typically less than 500 useconds.

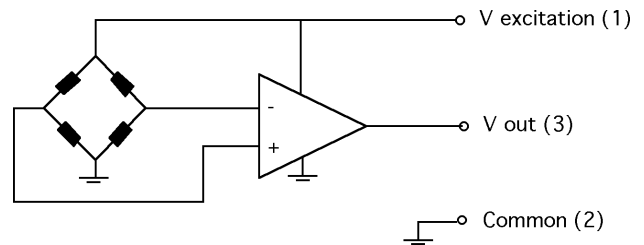

Specification Notes

NOTE 1: ALL PARAMETERS ARE MEASURED AT 5.0 VOLT EXCITATION, FOR THE NOMINAL FULL SCALE PRESSURE AND ROOM TEMPERATURE UNLESS OTHERWISE SPECIFIED. PRESSURE MEASUREMENTS ARE WITH POSITIVE PRESSURE APPLIED TO PORT B.

NOTE 2: SHIFT IS RELATIVE TO 25°C.

NOTE 3: SHIFT IS WITHIN THE FIRST HOUR OF EXCITATION APPLIED TO THE DEVICE.

NOTE 4: MEASURED AT ONE-HALF FULL SCALE RATED PRESSURE USING BEST STRAIGHT LINE CURVE FIT.

NOTE 5: THE VOLTAGE ADDED TO THE OFFSET VOLTAGE AT FULL SCALE PRESSURE. NOMINALLY THE OUTPUT VOLTAGE RANGE IS 0.25 TO 4.25 VOLTS FOR MINUS TO PLUS FULL SCALE PRESSURE.

All Sensors reserves the right to make changes to any products herein. All Sensors does not assume any liability arising out of the application or use of any product or circuit described herein, neither does it convey any license under its patent rights nor the rights of others.

Amplified Middle Pressure Sensors Military Grade

BAROMETRIC PRESSURE SENSORS

Barometric Pressure Sensors

600 to 1,100 mbar Barometric Pressure



Options:

- Ratiometric Output
- Fixed 4V Output with internal Voltage Reference
- Temperature Compensated (-25C to 85C, -40C to 125C, 5 C to 50C)
- Calibrated Zero and Span

Applications

- Medical Instrumentation
- Environmental Controls
- Chemical Analysis

General Description

These Barometric pressure sensors are based upon a proprietary package technology to reduce errors. This model provides a fixed 4-volt output with superior output characteristics. The sensor housing has been designed specifically to reduce package induced parasitic stress and strain. In addition the sensor utilizes a silicon, micromachined (MEMS) structure to provide a very linear output to measured pressure. The sensor embodies a vacuum reference.

These calibrated and temperature compensated sensors give an accurate and stable output over a wide temperature range. Each sensor is internally compensated using an ASIC compensation technique. This series is intended for use with non-corrosive, non-ionic working fluids such as air, dry gases and the like.

Physical Dimensions

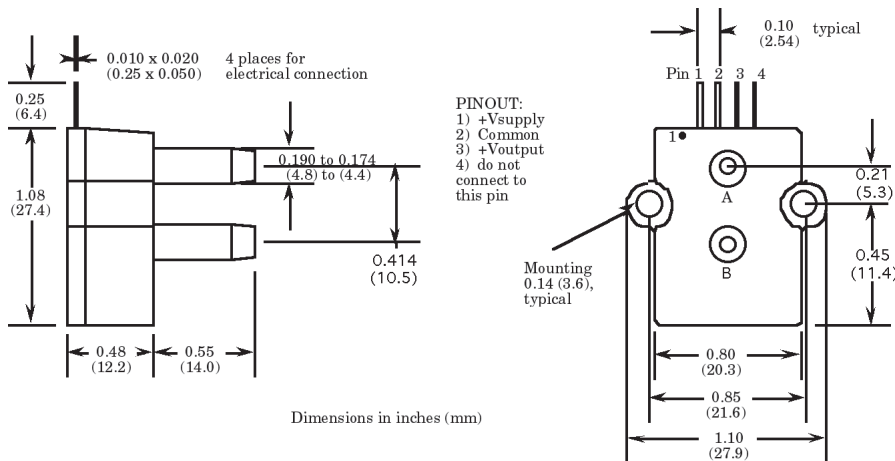

Pressure Sensor Ratings

Lead Temperature, max (soldering 2-4 sec.)	250°C
Burst Pressure	60 psi

Environmental Specifications

Temperature Ranges	
Compensated	see below
Operating	-40 to 125° C
Storage	-40 to 125° C
Humidity Limits	0 to 95% RH (non condensing)

Standard Pressure Ranges

Part Number	Operating Pressure	Supply Voltage	Compensated Temperature Range
BARO-A-4V	600 - 1100 mbar	4.5 to 5.5 V	5C to 50C
BARO-A-4V-PRIME	600 - 1100 mbar	4.5 to 5.5 V	-25C to 85C
BARO-A-4V-MIL	600 - 1100 mbar	4.5 to 5.5 V	-40C to 125C
BARO-A-4V-PRIME-REF	600 - 1100 mbar	5.5 to 16 V	-25C to 85C

Performance Characteristics for BARO-A-4V

Parameter, note 1	Minimum	Nominal	Maximum	Units
Operating Range, absolute pressure	600		1100	mBar
Output Voltage @1,100 mbar	4.20	4.25	4.30	volt
Output Voltage @ 600 mbar	0.20	0.25	0.30	volt
Offset Temperature Shift (5°C to 50°C), note 2			±20	mvolt
Linearity, hysteresis error, note 4		0.05	0.25	%fs
Span Shift (5°C to 50°C), note 2			±1	%span

Performance Characteristics for BARO-A-4V-PRIME

Parameter, note 1	Minimum	Nominal	Maximum	Units
Operating Range, absolute pressure	600		1100	mBar
Output Voltage @ 1,100 mbar	4.20	4.25	4.30	volt
Output Voltage @ 600 mbar	0.20	0.25	0.30	volt
Offset Temperature Shift (-25°C to 85°C), note 2			±20	mvolt
Linearity, hysteresis error, note 4		0.05	0.25	%fs
Span Shift (-25°C to 85°C), note 2			±1	%span

Performance Characteristics for BARO-A-4V-MIL

Parameter, note 1	Minimum	Nominal	Maximum	Units
Operating Range, absolute pressure	600		1100	mBar
Output Voltage @ 1,100 mbar	4.20	4.25	4.30	volt
Output Voltage @ 600 mbar	0.20	0.25	0.30	volt
Offset Temperature Shift (-40°C to 125°C), note 2			±20	mvolt
Linearity, hysteresis error, note 4		0.05	0.25	%fs
Span Shift (-40°C to 125°C), note 2			±1	%span

Performance Characteristics for BARO-A-4V-PRIME-REF

Parameter, note 1	Minimum	Nominal	Maximum	Units
Operating Range, absolute pressure	600		1100	mBar
Output Voltage @ 1,100 mbar	4.20	4.25	4.30	volt
Output Voltage @ 600 mbar	0.20	0.25	0.30	volt
Offset Temperature Shift (-25°C to 85°C), note 2			±20	mvolt
Linearity, hysteresis error, note 4		0.05	0.25	%fs
Span Shift (-25°C to 85°C), note 2			±1	%span

Equivalent Circuit

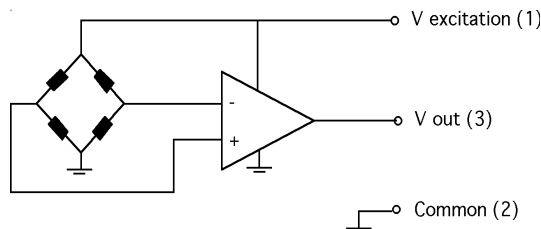

Equivalent Circuit with Internal Voltage Reference

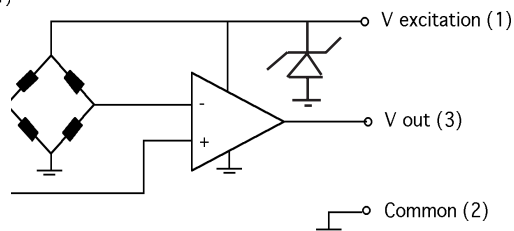

Specification Notes

NOTE 1: ALL PARAMETERS ARE MEASURED AT 5.0 VOLT EXCITATION FOR RATIOMETRIC PARTS AND 12.0 FOR PARTS WITH INTERNAL REFERENCE, FOR THE NOMINAL FULL SCALE PRESSURE AND ROOM TEMPERATURE UNLESS OTHERWISE SPECIFIED.

NOTE 2: SHIFT IS RELATIVE TO 25°C.

NOTE 3: SHIFT IS WITHIN THE FIRST HOUR OF EXCITATION APPLIED TO THE DEVICE.

NOTE 4: MEASURED AT ONE-HALF FULL SCALE RATED PRESSURE USING BEST STRAIGHT LINE CURVE FIT.

All Sensors reserves the right to make changes to any products herein. All Sensors does not assume any liability arising out of the application or use of any product or circuit described herein, neither does it convey any license under its patent rights nor the rights of others.

ASCX SERIES COMPATIBLE PRESSURE SENSORS

COMPATIBLE TO SENSYM ASCX SERIES



Features

- 5 Vdc Supply
- High Level Voltage Output
- Ratiometric 4.5 V Span
- Temperature Compensated
- Calibrated Zero and Span
- MULTIPLE Pressure Ranges

Applications

- Medical Instrumentation
- Environmental Instrumentation
- HVAC Instrumentation
- Pneumatic Controls

General Description

The Amplified line of middle pressure sensors is based upon a proprietary package technology to reduce errors. This model provides a ratiometric 4.5-volt output span with superior output characteristics. The sensor housing has been designed specifically to reduce package induced parasitic stress and strain. In addition the sensor utilizes a silicon, micromachined, stress concentration enhanced structure to provide a very linear output to measured pressure.

These calibrated and temperature compensated sensors give an accurate and stable output over a wide temperature range. Each sensor is internally compensated using an ASIC compensation technique. This series is intended for use with non-corrosive, non-ionic working fluids such as air, dry gases and the like.

The output of the device is ratiometric to the supply voltage over a supply voltage range of 4.5 to 5.5 volts.

Physical Dimensions

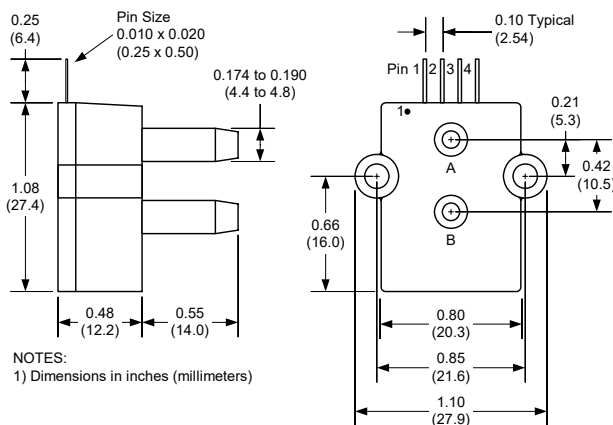

Equivalent Circuit

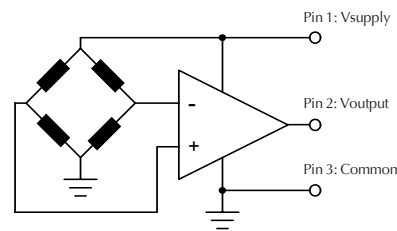

- Pin 1: Vsupply
- Pin 2: Voutput
- Pin 3: Common
- Pin 4: Do not connect

All Sensors reserves the right to make changes to any products herein. All Sensors does not assume any liability arising out of the application or use of any product or circuit described herein, neither does it convey any license under its patent rights nor the rights of others.

ALL SENSORS

06/20/2006

ASCX SERIES COMPATIBLE REV A

DS-0023 Rev A

Maximum Ratings

Supply Voltage, V_s	+4.5 to +5.5 Vdc
Lead Soldering Temperature (2-4 sec.)	250 °C
Quiescent Current ⁽⁶⁾	7.5 mA

Environmental Specifications

Compensated Temperature	0 to 70°C
Operating Temperature	-25 to 105°C
Storage Temperature	-55 to 125°C
Humidity Limits (non condensing)	0 to 95% RH

Pressure Ranges

Part Number	Operating Pressure	Proof Pressure	Burst Pressure
1 PSI-D-4V-ASCX	0 - 1 PSID	5 PSI	10 PSI
5 PSI-D-4V-ASCX	0 - 5 PSID	15 PSI	30 PSI
15 PSI-D-4V-ASCX	0 - 15 PSID	45 PSI	75 PSI
15 PSI-A-4V-ASCX	0 - 15 PSIA	45 PSI	75 PSI
30 PSI-D-4V-ASCX	0 - 30 PSID	100 PSI	150 PSI
30 PSI-A-4V-ASCX	0 - 30 PSIA	100 PSI	150 PSI
100 PSI-D-4V-ASCX	0 - 100 PSID	150 PSI	150 PSI
100 PSI-A-4V-ASCX	0 - 100 PSIA	150 PSI	150 PSI

Performance Characteristics for 1/5 PSI-D-4V-ASCX

Parameter ⁽¹⁾	Minimum	Nominal	Maximum	Units
Output Span ⁽⁵⁾	4.43	4.50	4.57	Volt
Span Shift (0 °C to 70 °C)	-	±0.2	±1.5	%Span
Offset Voltage @ zero pressure	0.18	0.25	0.32	Volt
Offset Shift (0 °C to 70 °C) ⁽²⁾	-	±0.5	±1.5	%Span
Combined Linearity and Hysteresis Error ⁽⁴⁾	-	±0.1	±0.5	%Span
Repeatability ⁽⁷⁾	-	±0.2	±0.5	% Span
Response Time ⁽⁸⁾	-	100	-	uSec

Performance Characteristics for 15/30/100 PSI-x-4V-ASCX

Parameter ⁽¹⁾	Minimum	Nominal	Maximum	Units
Output Span ⁽⁵⁾	4.45	4.50	4.55	Volt
Span Shift (0 °C to 70 °C)	-	±0.2	±1.0	%Span
Offset Voltage @ zero pressure	0.20	0.25	0.30	Volt
Offset Shift (0 °C to 70 °C) ⁽²⁾	-	±0.5	±1.0	%Span
Combined Linearity and Hysteresis Error ⁽⁴⁾	-	±0.1	±0.5	%Span
Repeatability ⁽⁷⁾	-	±0.2	±0.5	% Span
Response Time ⁽⁸⁾	-	100	-	uSec

Specification Notes

- 1) ALL PARAMETERS ARE MEASURED AT 5.0 VOLT EXCITATION, FOR THE NOMINAL FULL SCALE PRESSURE AND ROOM TEMPERATURE UNLESS OTHERWISE SPECIFIED. PRESSURE MEASUREMENTS ARE WITH POSITIVE PRESSURE APPLIED TO PORT B. ABSOLUTE DEVICES ARE WITH PRESSURE APPLIED TO PORT A.
- 2) SHIFT IS RELATIVE TO 25°C.
- 4) MEASURED AT ONE-HALF FULL SCALE RATED PRESSURE USING BEST STRAIGHT LINE CURVE FIT FOR THE SPAN INDICATED.
- 5) THE VOLTAGE ADDED TO THE OFFSET VOLTAGE AT FULL SCALE PRESSURE. NOMINALLY THE OUTPUT VOLTAGE RANGE IS 0.25 TO 4.75 VOLTS FOR MINUS TO PLUS FULL SCALE PRESSURE.
- 6) PARAMETER IS COMPUTED AS MAXIMUM FOR DESIGN REFERENCE AND IS NOT TESTED.
- 7) MAXIMUM DIFFERENCE IN OUTPUT AT ANY PRESSURE WITHIN THE OPERATING PRESSURE RANGE AND COMPENSATED TEMPERATURE RANGE AFTER: A) 1000 TEMPERATURE CYCLES AND B) 1.0 MILLION PRESSURE CYCLES.
- 8) RESPONSE TIME FOR A ZERO TO FULL SCALE PRESSURE STEP CHANGE, 10% TO 90% RISE TIME.

ASCX SERIES COMPATIBLE REV A

DS-0023 Rev A

Pressure Sensor Characteristics Maximum Ratings

Supply Voltage, Vs	+4.5 to +5.5 Vdc
Common-mode pressure	10 psig
Lead Temperature (soldering 2-4 sec.)	250°C

Environmental Specifications

Temperature Ranges	
Compensated	5 to 50° C
Operating	-25 to 85° C
Storage	-40 to 125° C
Humidity Limits	0 to 95% RH (non condensing)

Standard Pressure Ranges

Part Number	Operating Pressure	Nominal Span	Proof Pressure	Burst Pressure
0.5 INCH-Dx-4V-MINI	± 0.5 inH2O	4 V	100 inH2O	200 inH2O
1 INCH-Dx-4V-MINI	±1 inH2O	4 V	100 inH2O	200 inH2O
1 INCH-G-4V-MINI	0 - 1 inH2O	4 V	100 inH2O	200 inH2O
5 INCH-Dx-4V-MINI	± 5 inH2O	4 V	200 inH2O	300 inH2O
5 INCH-G-4V-MINI	0 - 5 inH2O	4 V	200 inH2O	300 inH2O
10 INCH-Dx-4V-MINI	±10 inH2O	4 V	200 inH2O	300 inH2O
10 INCH-G-4V-MINI	0 - 10 inH2O	4 V	200 inH2O	300 inH2O
20 INCH-Dx-4V-MINI	±20 inH2O	4 V	300 inH2O	500 inH2O
20 INCH-G-4V-MINI	0 - 20 inH2O	4 V	300 inH2O	500 inH2O
30 INCH-Dx-4V-MINI	±30 inH2O	4 V	500 inH2O	800 inH2O
30 INCH-G-4V-MINI	0 - 30 inH2O	4 V	500 inH2O	800 inH2O

For differential pressure D1 is the package with two pressure ports the same side, D2 has two ports the opposite sides.

Performance Characteristics for 0.5 INCH-Dx-4V-MINI

Parameter, note 1	Minimum	Nominal	Maximum	Units
Operating Range, differential pressure	-	±0.5	-	inH2O
Output Span, note 5	±1.90	±2.0	±2.10	V
Offset Voltage @ zero differential pressure	2.15	2.25	2.35	V
Offset Temperature Shift (5°C-50°C), note 2	-	-	±120	mV
Offset Warm-up Shift, note 3	-	±10	-	mV
Offset Position Sensitivity (±1g)	-	±5	-	mV
Offset Long Term Drift (one year)	-	±10	-	mV
Linearity, hysteresis error, note 4	-	0.05	0.25	%FSS
Span Shift (5°C-50°C), note 2	-	-	±2	%FSS

Miniature Amplified Low Pressure Sensors

Performance Characteristics for: 5 INCH-G-4V-MINI

Parameter, NOTE 1	Minimum	Nominal	Maximum	Units
Operating Range, gage pressure	-	5.0	-	inH2O
Output Span, NOTE 5	3.90	4.0	4.10	V
Offset Voltage @ zero pressure	0.15	0.25	0.35	V
Offset Temperature Shift (5°C-50°C), NOTE 2	-	-	±40	mV
Offset Warm-up Shift, NOTE 3	-	±5	-	mV
Offset Position Sensitivity (±1g)	-	±5	-	mV
Offset Long Term Drift (one year)	-	±5	-	mV
Linearity, hysteresis error, NOTE 4	-	0.05	0.25	%FSS
Span Shift (5°C-50°C), NOTE 2	-	-	±1	%FSS

Performance Characteristics for: 10 INCH-Dx-4V-MINI

Parameter, NOTE 1	Minimum	Nominal	Maximum	Units
Operating Range, differential pressure	-	±10.0	-	inH2O
Output Span, NOTE 5	±1.90	±2.0	±2.10	V
Offset Voltage @ zero differential pressure	2.15	2.25	2.35	V
Offset Temperature Shift (5°C-50°C), NOTE 2	-	-	±20	mV
Offset Warm-up Shift, NOTE 3	-	±5	-	mV
Offset Position Sensitivity (±1g)	-	±5	-	mV
Offset Long Term Drift (one year)	-	±5	-	mV
Linearity, hysteresis error, NOTE 4	-	0.05	0.25	%FSS
Span Shift (5°C-50°C), NOTE 2	-	-	±1	%FSS

Performance Characteristics for: 10 INCH-G-4V-MINI

Parameter, NOTE 1	Minimum	Nominal	Maximum	Units
Operating Range, gage pressure	-	10.0	-	inH2O
Output Span, NOTE 5	3.90	4.0	4.10	V
Offset Voltage @ zero pressure	0.15	0.25	0.35	V
Offset Temperature Shift (5°C-50°C), NOTE 2	-	-	±20	mV
Offset Warm-up Shift, NOTE 3	-	±5	-	mV
Offset Position Sensitivity (±1g)	-	±5	-	mV
Offset Long Term Drift (one year)	-	±5	-	mV
Linearity, hysteresis error, NOTE 4	-	0.05	0.25	%FSS
Span Shift (5°C-50°C), NOTE 2	-	-	±1	%FSS

Miniature Amplified Low Pressure Sensors

Performance Characteristics for 20 INCH-Dx-4V-MINI

Parameter, note 1	Minimum	Nominal	Maximum	Units
Operating Range, differential pressure	-	±20.0	-	inH2O
Output Span, note 5	±1.90	±2.0	±2.10	V
Offset Voltage @ zero differential pressure	2.15	2.25	2.35	V
Offset Temperature Shift (5°C-50°C), note 2	-	-	±20	mV
Offset Warm-up Shift, note 3	-	±5	-	mV
Offset Position Sensitivity (±1g)	-	±5	-	mV
Offset Long Term Drift (one year)	-	±5	-	mV
Linearity, hysteresis error, note 4	-	0.05	0.25	%FSS
Span Shift (5°C-50°C), note 2	-	-	±1	%FSS

Performance Characteristics for 20 INCH-G-4V-MINI

Parameter, note 1	Minimum	Nominal	Maximum	Units
Operating Range, gage pressure	-	20.0	-	inH2O
Output Span, note 5	3.90	4.0	4.1	V
Offset Voltage @ zero pressure	0.15	0.25	0.35	V
Offset Temperature Shift (5°C-50°C), note 2	-	-	±20	mV
Offset Warm-up Shift, note 3	-	±5	-	mV
Offset Position Sensitivity (±1g)	-	±5	-	mV
Offset Long Term Drift (one year)	-	±5	-	mV
Linearity, hysteresis error, note 4	-	0.05	0.25	%FSS
Span Shift (5°C-50°C), note 2	-	-	±1	%FSS

Performance Characteristics for 30 INCH-Dx-4V-MINI

Parameter, note 1	Minimum	Nominal	Maximum	Units
Operating Range, differential pressure	-	±30.0	-	inH2O
Output Span, note 5	±1.90	±2.0	±2.10	V
Offset Voltage @ zero differential pressure	2.15	2.25	2.35	V
Offset Temperature Shift (5°C-50°C), note 2	-	-	±20	mV
Offset Warm-up Shift, note 3	-	±5	-	mV
Offset Position Sensitivity (±1g)	-	±5	-	mV
Offset Long Term Drift (one year)	-	±5	-	mV
Linearity, hysteresis error, note 4	-	0.05	0.25	%FSS
Span Shift (5°C-50°C), note 2	-	-	±1	%FSS

Performance Characteristics for 30 INCH-G-4V-MINI

Parameter, NOTE 1	Minimum	Nominal	Maximum	Units
Operating Range, gage pressure	-	30.0	-	inH2O
Output Span, NOTE 5	3.9	4.0	4.1	V
Offset Voltage @ zero pressure	0.15	0.25	0.35	V
Offset Temperature Shift (5°C-50°C), NOTE 2	-	-	±20	mV
Offset Warm-up Shift, NOTE 3	-	±5	-	mV
Offset Position Sensitivity (±1g)	-	±5	-	mV
Offset Long Term Drift (one year)	-	±5	-	mV
Linearity, hysteresis error, NOTE 4	-	0.05	0.25	%FSS
Span Shift (5°C-50°C), NOTE 2	-	-	±1	%FSS

Pressure Response: for any pressure applied the response time to get to 90% of pressure applied is typically less than 500 useconds.

Specification Notes

NOTE 1: ALL PARAMETERS ARE MEASURED AT 5.0 VOLT EXCITATION, FOR THE NOMINAL FULL SCALE PRESSURE AND ROOM TEMPERATURE UNLESS OTHERWISE SPECIFIED.

PRESSURE MEASUREMENTS ARE WITH POSITIVE PRESSURE APPLIED TO THE B-PORT.

NOTE 2: SHIFT IS RELATIVE TO 25°C.

NOTE 3: SHIFT IS WITHIN THE FIRST HOUR OF EXCITATION APPLIED TO THE DEVICE.

NOTE 4: MEASURED AT ONE-HALF FULL SCALE RATED PRESSURE USING BEST STRAIGHT LINE CURVE FIT.

NOTE 5: THE VOLTAGE ADDED TO THE OFFSET VOLTAGE AT FULL SCALE PRESSURE. NOMINALLY THE OUTPUT VOLTAGE RANGE IS 0.25 TO 4.25 VOLTS FOR MINUS TO PLUS FULL SCALE PRESSURE.

All Sensors reserves the right to make changes to any products herein. All Sensors does not assume any liability arising out of the application or use of any product or circuit described herein, neither does it convey any license under its patent rights nor the rights of others.

MINIATURE AMPLIFIED LOW PRESSURE SENSORS

Low Pressure (1" H₂O to 30" H₂O) Sensors
PRIME GRADE



Features

- 0 to 1" H₂O to 0 to 30" H₂O Pressure Ranges
- Matched pressure port volumes
- Temperature Compensated (-25 to 85° C)
- Calibrated Zero and Span

Applications

- Medical Instrumentation
- Environmental Controls
- HVAC

General Description

The Miniature Amplified Output pressure sensors is based upon a proprietary technology to reduce all output offset or common mode errors. This model provides a calibrated amplified output with superior output offset characteristics. Output offset errors due to change in temperature, stability to warm-up, stability to long time period, and position sensitivity are all significantly reduced when compared to conventional compensation methods. In addition the sensor utilizes a silicon, micromachined, stress concentration enhanced structure to provide a very linear output to measured pressure.

These calibrated and temperature compensated sensors give an accurate and stable output over a wide temperature range. This series is intended for use with non-corrosive, non-ionic working fluids such as air, dry gases and the like.

The output of the device is ratiometric to the supply voltage and operation from any D.C. supply voltage between 4.5 and 5.5 volts.

Physical Dimensions

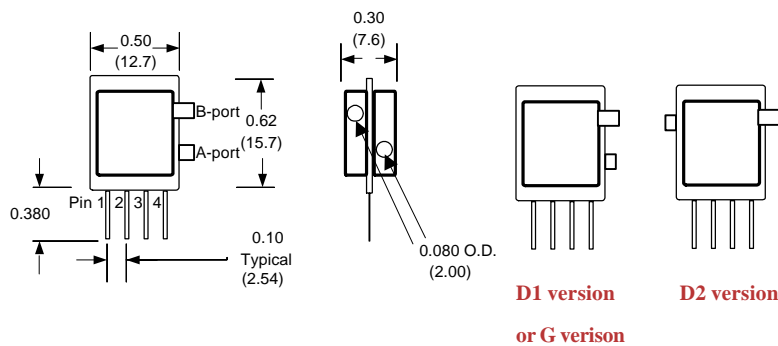

Equivalent Circuit

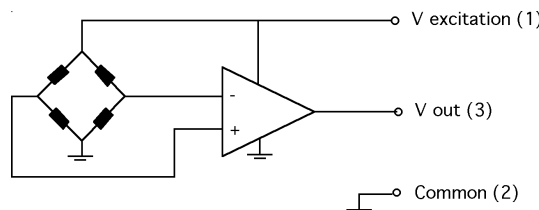

Pressure Sensor Characteristics Maximum Ratings

Supply Voltage V_S	+4.5 to +5.5
Common-mode pressure	Vdc
Lead Temperature (soldering 2-4 sec.)	10 psig 250°C

Environmental Specifications

Temperature Ranges	
Compensated	-25 to 85° C
Operating	-40 to 125° C
Storage	-40 to 125° C
Humidity Limits	0 to 95% RH (non condensing)

Standard Pressure Ranges

Part Number	Operating Pressure	Nominal Span	Proof Pressure	Burst Pressure
1 INCH-Dx-P4V-MINI	±1 In H ₂ O	4 V	100 In H ₂ O	200 In H ₂ O
1 INCH-G-P4V-MINI	0 - 1 In H ₂ O	4 V	300 In H ₂ O	200 In H ₂ O
5 INCH-Dx-P4V-MINI	±5 In H ₂ O	4 V	200 In H ₂ O	300 In H ₂ O
5 INCH-G-P4V-MINI	0 - 5 In H ₂ O	4 V	200 In H ₂ O	300 In H ₂ O
10 INCH-Dx-P4V-MINI	±10 In H ₂ O	4 V	200 In H ₂ O	300 In H ₂ O
10 INCH-G-P4V-MINI	0 - 10 In H ₂ O	4 V	200 In H ₂ O	300 In H ₂ O
20 INCH-Dx-P4V-MINI	±20 In H ₂ O	4 V	300 In H ₂ O	500 In H ₂ O
20 INCH-G-P4V-MINI	0 - 20 In H ₂ O	4 V	300 In H ₂ O	500 In H ₂ O
30 INCH-Dx-P4V-MINI	±30 In H ₂ O	4 V	500 In H ₂ O	800 In H ₂ O
30 INCH-G-P4V-MINI	0 - 30 In H ₂ O	4 V	500 In H ₂ O	800 In H ₂ O
60 INCH-Dx-P4V-MINI	±60 In H ₂ O	4V	500 In H ₂ O	800 In H ₂ O

For differential pressure D1 is the package with two pressure ports the same side, D2 has two ports the opposite sides.

Equivalent Circuit

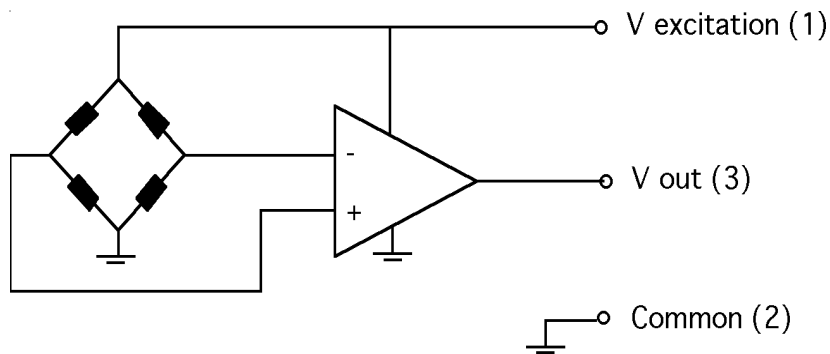

Performance Characteristics for 1 INCH-Dx-P4V-MINI

Parameter, note 1	Minimum	Nominal	Maximum	Units
Operating Range, differential pressure		±1.0		"H2O
Output Span, note 5	±1.90	±2.0	±2.10	volt
Offset Voltage @ zero differential pressure	2.15	2.25	2.35	volt
Offset Temperature Shift (-25°C-85°C), note 2			±60	mvolt
Offset Warm-up Shift, note 3		±10		mvolt
Offset Position Sensitivity (±1g)		±5		mvolt
Offset Long Term Drift (one year)		±10		mvolt
Linearity, hysteresis error, note 4		0.05	0.25	%fs
Span Shift (-25°C-85°C), note 2			±2	%span

Performance Characteristics for 1 INCH-G-P4V-MINI

Parameter, note 1	Minimum	Nominal	Maximum	Units
Operating Range, gage pressure		1.0		"H2O
Output Span, note 5	3.90	4.0	4.10	volt
Offset Voltage @ zero pressure	0.15	0.25	0.35	volt
Offset Temperature Shift (-25°C-85°C), note 2			±60	mvolt
Offset Warm-up Shift, note 3		±10		mvolt
Offset Position Sensitivity (±1g)		±15		mvolt
Offset Long Term Drift (one year)		±10		mvolt
Linearity, hysteresis error, note 4		0.05	0.25	%fs
Span Shift (5°C-50°C), note 2			±2	%span

Performance Characteristics for 5 INCH-Dx-P4V-MINI

Parameter, note 1	Minimum	Nominal	Maximum	Units
Operating Range, differential pressure		±5.0		"H2O
Output Span, note 5	±1.90	±2.0	±2.10	volt
Offset Voltage @ zero differential pressure	2.15	2.25	2.35	volt
Offset Temperature Shift (-25°C-85°C), note 2			±40	mvolt
Offset Warm-up Shift, note 3		±5		mvolt
Offset Position Sensitivity (±1g)		±5		mvolt
Offset Long Term Drift (one year)		±5		mvolt
Linearity, hysteresis error, note 4		0.05	0.25	%fs
Span Shift (-25°C-85°C), note 2			±1	%span



Performance Characteristics for: 5 INCH-G-P4V-MINI

Parameter, NOTE 1	Minimum	Nominal	Maximum	Units
Operating Range, gage pressure		5.0		mbar
Output Span, NOTE 5	3.90	4.0	4.10	volt
Offset Voltage @ zero pressure	0.15	0.25	0.35	volt
Offset Temperature Shift (-25°C-85°C), NOTE 2			±40	mvolt
Offset Warm-up Shift, NOTE 3		±5		mvolt
Offset Position Sensitivity (±1g)		±5		mvolt
Offset Long Term Drift (one year)		±5		mvolt
Linearity, hysteresis error, NOTE 4		0.05	0.25	%fs
Span Shift (-25°C-85°C), NOTE 2			±1	%span

Performance Characteristics for: 10 INCH-Dx-P4V-MINI

Parameter, NOTE 1	Minimum	Nominal	Maximum	Units
Operating Range, differential pressure		±10.0		mbar
Output Span, NOTE 5	±1.90	±2.0	±2.10	volt
Offset Voltage @ zero differential pressure	2.15	2.25	2.35	volt
Offset Temperature Shift (-25°C-85°C), NOTE 2			±20	mvolt
Offset Warm-up Shift, NOTE 3		±5		mvolt
Offset Position Sensitivity (±1g)		±5		mvolt
Offset Long Term Drift (one year)		±5		mvolt
Linearity, hysteresis error, NOTE 4		0.05	0.25	%fs
Span Shift (-25°C-85°C), NOTE 2			±1	%span

Performance Characteristics for: 10 INCH-G-P4V-MINI

Parameter, NOTE 1	Minimum	Nominal	Maximum	Units
Operating Range, gage pressure		10.0		mbar
Output Span, NOTE 5	3.90	4.0	4.10	volt
Offset Voltage @ zero pressure	0.15	0.25	0.35	volt
Offset Temperature Shift (-25°C-85°C), NOTE 2			±20	mvolt
Offset Warm-up Shift, NOTE 3		±5		mvolt
Offset Position Sensitivity (±1g)		±5		mvolt
Offset Long Term Drift (one year)		±5		mvolt
Linearity, hysteresis error, NOTE 4		0.05	0.25	%fs
Span Shift (-25°C-85°C), NOTE 2			±1	%span

Performance Characteristics for 20 INCH-Dx-P4V-MINI

Parameter, note 1	Minimum	Nominal	Maximum	Units
Operating Range, differential pressure		±20.0		"H2O
Output Span, note 5	±1.90	±2.0	±2.10	volt
Offset Voltage @ zero differential pressure	2.15	2.25	2.35	volt
Offset Temperature Shift (-25°C-85°C), note 2			±20	mvolt
Offset Warm-up Shift, note 3		±5		mvolt
Offset Position Sensitivity (±1g)		±5		mvolt
Offset Long Term Drift (one year)		±5		mvolt
Linearity, hysteresis error, note 4		0.05	0.25	%fs
Span Shift (-25°C-85°C), note 2			±1	%span

Performance Characteristics for 20 INCH-G-P4V-MINI

Parameter, note 1	Minimum	Nominal	Maximum	Units
Operating Range, gage pressure		20.0		"H2O
Output Span, note 5	3.90	4.0	4.1	volt
Offset Voltage @ zero pressure	0.15	0.25	0.35	volt
Offset Temperature Shift (-25°C-85°C), note 2			±20	mvolt
Offset Warm-up Shift, note 3		±5		mvolt
Offset Position Sensitivity (±1g)		±5		mvolt
Offset Long Term Drift (one year)		±5		mvolt
Linearity, hysteresis error, note 4		0.05	0.25	%fs
Span Shift (-25°C-85°C), note 2			±1	%span

Performance Characteristics for 30 INCH-Dx-P4V-MINI

Parameter, note 1	Minimum	Nominal	Maximum	Units
Operating Range, differential pressure		±30.0		"H2O
Output Span, note 5	±1.90	±2.0	±2.10	volt
Offset Voltage @ zero differential pressure	2.15	2.25	2.35	volt
Offset Temperature Shift (-25°C-85°C), note 2			±20	mvolt
Offset Warm-up Shift, note 3		±5		mvolt
Offset Position Sensitivity (±1g)		±5		mvolt
Offset Long Term Drift (one year)		±5		mvolt
Linearity, hysteresis error, note 4		0.05	0.25	%fs
Span Shift (-25°C-85°C), note 2			±1	%span



Performance Characteristics for 30 INCH-G-P4V-MINI

Parameter, NOTE 1	Minimum	Nominal	Maximum	Units
Operating Range, gage pressure		30.0		"H ₂ O
Output Span, NOTE 5	3.9	4.0	4.1	volt
Offset Voltage @ zero pressure	0.15	0.25	0.35	volt
Offset Temperature Shift (-25°C-85°C), NOTE 2			±20	mvolt
Offset Warm-up Shift, NOTE 3		±5		mvolt
Offset Position Sensitivity (±1g)		±5		mvolt
Offset Long Term Drift (one year)		±5		mvolt
Linearity, hysteresis error, NOTE 4		0.05	0.25	%fs
Span Shift (-25°C-85°C), NOTE 2			±1	%span

Performance Characteristics for 60 INCH-Dx-P4V-MINI

Parameter, note 1	Minimum	Nominal	Maximum	Units
Operating Range, differential pressure		±60.0		"H ₂ O
Output Span, note 5	±1.90	±2.0	±2.10	volt
Offset Voltage @ zero differential pressure	2.15	2.25	2.35	volt
Offset Temperature Shift (-25°C-85°C), note 2			±20	mvolt
Offset Warm-up Shift, note 3		±5		mvolt
Offset Position Sensitivity (±1g)		±5		mvolt
Offset Long Term Drift (one year)		±5		mvolt
Linearity, hysteresis error, note 4		0.05	0.25	%fs
Span Shift (-25°C-85°C), note 2			±1	%span

Pressure Response: for any pressure applied the response time to get to 90% of pressure applied is typically less than 100 useconds.

Specification Notes

NOTE 1: ALL PARAMETERS ARE MEASURED AT 5.0 VOLT EXCITATION, FOR THE NOMINAL FULL SCALE PRESSURE AND ROOM TEMPERATURE UNLESS OTHERWISE SPECIFIED. PRESSURE MEASUREMENTS ARE WITH POSITIVE PRESSURE APPLIED TO THE FRONT PORT.

NOTE 2: SHIFT IS RELATIVE TO 25°C.

NOTE 3: SHIFT IS WITHIN THE FIRST HOUR OF EXCITATION APPLIED TO THE DEVICE.

NOTE 4: MEASURED AT ONE-HALF FULL SCALE RATED PRESSURE USING BEST STRAIGHT LINE CURVE FIT.

NOTE 5: THE VOLTAGE ADDED TO THE OFFSET VOLTAGE AT FULL SCALE PRESSURE. NOMINALLY THE OUTPUT VOLTAGE RANGE IS 0.25 TO 4.25 VOLTS FOR MINUS TO PLUS FULL SCALE PRESSURE.

All Sensors reserves the right to make changes to any products herein. All Sensors does not assume any liability arising out of the application or use of any product or circuit described herein, neither does it convey any license under its patent rights nor the rights of others.

MINIATURE AMPLIFIED PRESSURE SENSORS

cm H₂O calibrated for Medical applications



Features

- cm H₂O Pressure Ranges
- Matched pressure port volumes
- Temperature Compensated
- Calibrated Zero and Span

Applications

- Medical Instrumentation
- Respiratory Breathing

General Description

The Miniature Amplified Output pressure sensors is based upon a proprietary technology to reduce all output offset or common mode errors. This model provides a calibrated amplified output with superior output offset characteristics. Output offset errors due to change in temperature, stability to warm-up, stability to long time period, and position sensitivity are all significantly reduced when compared to conventional compensation methods. In addition the sensor utilizes a silicon, micromachined, stress concentration enhanced structure to provide a very linear output to measured pressure.

These calibrated and temperature compensated sensors give an accurate and stable output over a wide temperature range. This series is intended for use with non-corrosive, non-ionic working fluids such as air, dry gases and the like.

The output of the device is ratiometric to the supply voltage and operation from any D.C. supply voltage between 4.5 and 5.5 volts.

Physical Dimensions

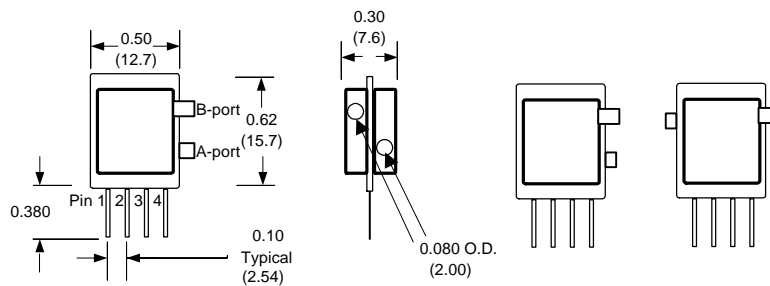

Pressure Sensor Characteristics Maximum Ratings

Supply Voltage VS	+4.5 to
Common-mode pressure	+75.5Vdc
Lead Temperature (soldering 2-4 sec.)	10 psig 250°C

Environmental Specifications

Temperature Ranges	
Compensated	see specification
Operating	-25 to 85° C
Storage	-40 to 125° C
Humidity Limits	0 to 95% RH (non condensing)

Standard Pressure Ranges

Part Number	Operating Pressure	Compensated Range	Proof Pressure	Burst Pressure
5 cmH2O-D1-4V-MINI	-0.2 to 5 cmH2O	5 to 50° C	50 cmH2O	200 cmH2O
20 cmH2O-D1-4V-MINI	-0.2 to 20 cmH2O	5 to 50° C	100 cmH2O	300 cmH2O
120 cmH2O-D1-4V-MINI	-10 to 120 cm H2O	5 to 50° C	300 cmH2O	600 cmH2O
5 cmH2O-D1-P4V-MINI	-0.2 to 5 cmH2O	-25 to 85° C	50 cmH2O	200 cmH2O
20 cmH2O-D1-P4V-MINI	-0.2 to 20 cmH2O	-25 to 85° C	100 cmH2O	300 cmH2O
120 cmH2O-D1-P4V-MINI	-10 to 120 cm H2O	-25 to 85° C	300 cmH2O	600 cmH2O

Specification Notes

NOTE 1: ALL PARAMETERS ARE MEASURED AT 5.0 VOLT EXCITATION, FOR THE NOMINAL FULL SCALE PRESSURE AND ROOM TEMPERATURE UNLESS OTHERWISE SPECIFIED. PRESSURE MEASUREMENTS ARE WITH POSITIVE PRESSURE APPLIED TO THE FRONT PORT.

NOTE 2: SHIFT IS RELATIVE TO 25°C.

NOTE 3: SHIFT IS WITHIN THE FIRST HOUR OF EXCITATION APPLIED TO THE DEVICE.

NOTE 4: MEASURED AT ONE-HALF FULL SCALE RATED PRESSURE USING BEST STRAIGHT LINE CURVE FIT.

NOTE 5: THE VOLTAGE ADDED TO THE OFFSET VOLTAGE AT FULL SCALE PRESSURE. NOMINALLY THE OUTPUT VOLTAGE RANGE IS 0.25 TO 4.25 VOLTS FOR MINUS TO PLUS FULL SCALE PRESSURE.

All Sensors reserves the right to make changes to any products herein. All Sensors does not assume any liability arising out of the application or use of any product or circuit described herein, neither does it convey any license under its patent rights nor the rights of others.

Equivalent Circuit

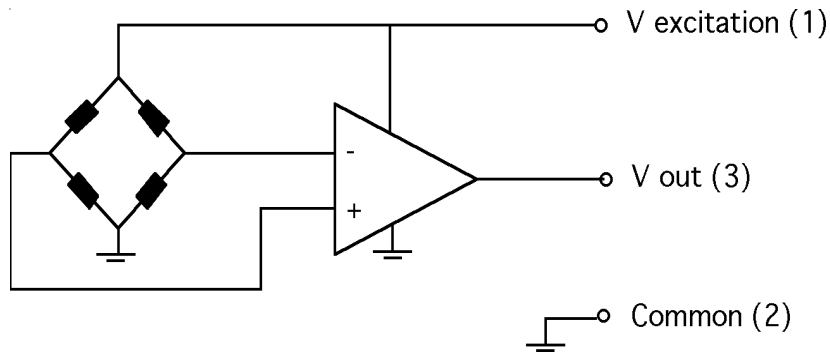

Performance Characteristics for 5 cmH2O-D1-4V-MINI

Parameter, note 1	Minimum	Nominal	Maximum	Units
Operating Range, pressure	-0.2		5	cmH2O
Output Voltage, @5 cmH2O	4.40	4.5	4.6	volt
Output Voltage @ zero pressure	0.30	0.35	0.40	volt
Output Voltage @-0.2 cmH2O	0.13	0.18	0.23	volt
Offset Temperature Shift (5°C-50°C), note 2			±1.0	%span
Offset Warm-up Shift, note 3		±15		mvolt
Offset Position Sensitivity (±1g)		±15		mvolt
Offset Long Term Drift (one year)		±20		mvolt
Linearity, hysteresis error, note 4		0.05	±0.25	%fs
Span Shift (5°C-50°C), note 2			±1.0	%span

Performance Characteristics for 20 cmH2O-D1-4V-MINI

Parameter, note 1	Minimum	Nominal	Maximum	Units
Operating Range, pressure	-0.2		20	cmH2O
Output Voltage, @20 cmH2O	4.40	4.5	4.6	volt
Output Voltage @ zero pressure	0.30	0.35	0.40	volt
Output Voltage @-0.2 cmH2O	0.25	0.30	0.35	volt
Offset Temperature Shift (5°C-50°C), note 2			±1.0	%span
Offset Warm-up Shift, note 3		±10		mvolt
Offset Position Sensitivity (±1g)		±10		mvolt
Offset Long Term Drift (one year)		±10		mvolt
Linearity, hysteresis error, note 4		0.05	±0.25	%fs
Span Shift (5°C-50°C), note 2			±1.0	%span

Performance Characteristics for 120 cmH2O-D1-4V-MINI

Parameter, note 1	Minimum	Nominal	Maximum	Units
Operating Range, pressure	-10		120	cmH2O
Output Voltage, @120 cmH2O	4.40	4.5	4.6	volt
Output Voltage @ zero pressure	0.30	0.35	0.40	volt
Output Voltage @-10 cmH2O	0.23	0.28	0.33	volt
Offset Temperature Shift (5°C-50°C), note 2			±1.0	%span
Offset Warm-up Shift, note 3		±15		mvolt
Offset Position Sensitivity (±1g)		±15		mvolt
Offset Long Term Drift (one year)		±20		mvolt
Linearity, hysteresis error, note 4		0.05	±0.25	%fs
Span Shift (5°C-50°C), note 2			±1.0	%span



Performance Characteristics for 5 cmH₂O-D1-P4V-MINI

Parameter, note 1	Minimum	Nominal	Maximum	Units
Operating Range, pressure	-0.2		5	cmH ₂ O
Output Voltage, @5 cmH ₂ O	4.40	4.5	4.6	volt
Output Voltage @ zero pressure	0.30	0.35	0.40	volt
Output Voltage @-0.2 cmH ₂ O	0.13	0.18	0.23	volt
Offset Temperature Shift (-25 to 85°C), note 2			±1.0	%span
Offset Warm-up Shift, note 3		±15		mvolt
Offset Position Sensitivity (±1g)		±15		mvolt
Offset Long Term Drift (one year)		±20		mvolt
Linearity, hysteresis error, note 4		0.05	±0.25	%fs
Span Shift (-25 to 85°C), note 2			±1.0	%span

Performance Characteristics for 20 cmH₂O-D1-P4V-MINI

Parameter, note 1	Minimum	Nominal	Maximum	Units
Operating Range, pressure	-0.2		20	cmH ₂ O
Output Voltage, @20 cmH ₂ O	4.40	4.5	4.6	volt
Output Voltage @ zero pressure	0.30	0.35	0.40	volt
Output Voltage @-0.2 cmH ₂ O	0.25	0.30	0.35	volt
Offset Temperature Shift (-25 to 85°C), note 2			±1.0	%span
Offset Warm-up Shift, note 3		±10		mvolt
Offset Position Sensitivity (±1g)		±10		mvolt
Offset Long Term Drift (one year)		±10		mvolt
Linearity, hysteresis error, note 4		0.05	±0.25	%fs
Span Shift (-25 to 85°C), note 2			±1.0	%span

Performance Characteristics for 120 cmH₂O-D1-P4V-MINI

Parameter, note 1	Minimum	Nominal	Maximum	Units
Operating Range, pressure	-10		120	cmH ₂ O
Output Voltage, @120 cmH ₂ O	4.40	4.5	4.6	volt
Output Voltage @ zero pressure	0.30	0.35	0.40	volt
Output Voltage @-10 cmH ₂ O	0.23	0.28	0.33	volt
Offset Temperature Shift (-25 to 85°C), note 2			±1.0	%span
Offset Warm-up Shift, note 3		±15		mvolt
Offset Position Sensitivity (±1g)		±15		mvolt
Offset Long Term Drift (one year)		±20		mvolt
Linearity, hysteresis error, note 4		0.05	±0.25	%fs
Span Shift (-25 to 85°C), note 2			±1.0	%span

MINIATURE AMPLIFIED MEDICAL RANGE PRESSURE SENSORS

Miniature Amplified Pressure Sensors

±0.3 psi to 100 psi Pressure Sensors



Features

- 0 to ±0.3 to 0 to 30 psi Pressure Ranges
- Ratiometric 4V Output
- Temperature Compensated
- Calibrated Zero and Span

Applications

- Medical Instrumentation
- Environmental Instrumentation
- HVAC Instrumentation

General Description

The Miniature Amplified line of pressure sensors is based upon technology developed over years of development in the pressure sensor industry. This model provides a ratiometric 4-volt output with superior output characteristics. The sensor housing has been designed specifically to reduce package induced parasitic stress and strain. In addition the sensor utilizes a silicon, micromachined, stress concentration enhanced structure to provide a very linear output to measured pressure.

These calibrated and temperature compensated sensors give an accurate and stable output over a wide temperature range. Each sensor is internally compensated using an ASIC compensation technique. This series is intended for use with non-corrosive, non-ionic working fluids such as air, dry gases and the like.

The output of the device is ratiometric to the supply voltage over a supply voltage range of 4.5 to 5.5 volts.

Physical Dimensions

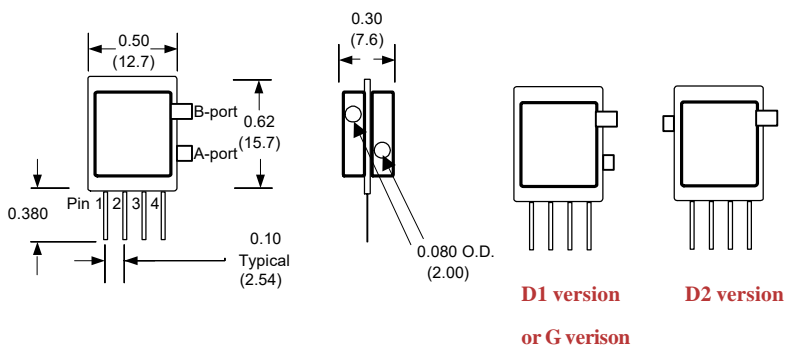

Equivalent Circuit

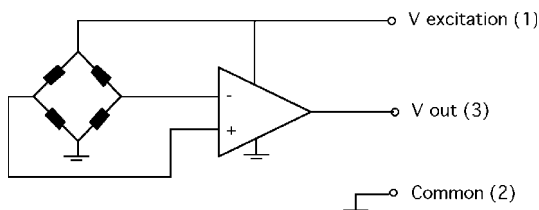

Pressure Sensor Ratings

Supply Voltage, Vs	+4.5 to +5.5 Vdc
Common-mode pressure	-10 to +10 psig
Lead Temperature, max (soldering 2-4 sec.)	250°C

Environmental Specifications

Temperature Ranges	
Compensated	5 to 50° C
Operating	-25 to 85° C
Storage	-40 to 125° C
Humidity Limits	0 to 95% RH (non condensing)

Standard Pressure Ranges

Part Number	Operating Pressure	Nominal Span	Proof Pressure	Burst Pressure
0.3 PSI-Dx-4V-MINI	±0.3 PSI	4 V	5 PSI	10 PSI
0.3 PSI-G-4V-MINI	0 - 0.3 PSI	4 V	5 PSI	10 PSI
1 PSI-Dx-4V-MINI	±1 PSI	4 V	5 PSI	10 PSI
1 PSI-G-4V-MINI	0 - 1 PSI	4 V	5 PSI	10 PSI
5 PSI-Dx-4V-MINI	± 5 PSI	4 V	15 PSI	30 PSI
5 PSI-G-4V-MINI	0 - 5 PSI	4 V	15 PSI	30 PSI
15 PSI-A-4V-MINI	0 - 15 PSIA	4 V	45 PSI	60 PSI
15 PSI-Dx-4V-MINI	±15 PSI	4 V	45 PSI	60 PSI
15 PSI-G-4V-MINI	0 - 15 PSI	4V	45 PSI	60 PSI
30 PSI-A-4V-MINI	0 - 30 PSIA	4V	60 PSI	60 PSI
30 PSI-Dx-4V-MINI	±30 PSI	4V	60 PSI	60 PSI
30 PSI-G-4V-MINI	0 - 30 PSI	4V	60 PSI	100 PSI
BARO-A-4V-MINI	600 - 1100 mbar	4V	45 PSI	60 PSI

Performance Characteristics for 0.3 PSI-Dx-4V-MINI

Parameter, note 1	Minimum	Nominal	Maximum	Units
Operating Range, differential pressure		±0.3		PSI
Output Span, note 5	±1.90	±20	±2.10	volt
Offset Voltage @ zero differential pressure	2.15	2.25	2.35	volt
Offset Temperature Shift (5°C-50°C), note 2			±40	mvolt
Linearity, hysteresis error, note 4			±0.5	%fs
Span Shift (5°C-50°C), note 2			±2	%span

Specification Notes

NOTE 1: ALL PARAMETERS ARE MEASURED AT 5.0 VOLT EXCITATION, FOR THE NOMINAL FULL SCALE PRESSURE AND ROOM TEMPERATURE UNLESS OTHERWISE SPECIFIED. PRESSURE MEASUREMENTS ARE WITH POSITIVE PRESSURE APPLIED TO PORT B.

NOTE 2: SHIFT IS RELATIVE TO 25°C.

NOTE 3: SHIFT IS WITHIN THE FIRST HOUR OF EXCITATION APPLIED TO THE DEVICE.

NOTE 4: MEASURED AT ONE-HALF FULL SCALE RATED PRESSURE USING BEST STRAIGHT LINE CURVE FIT.

NOTE 5: THE VOLTAGE ADDED TO THE OFFSET VOLTAGE AT FULL SCALE PRESSURE. NOMINALLY THE OUTPUT VOLTAGE RANGE IS 0.25 TO 4.25 VOLTS FOR MINUS TO PLUS FULL SCALE PRESSURE.

Performance Characteristics for 0.3 PSI-G-4V-MINI

Parameter, note 1	Minimum	Nominal	Maximum	Units
Operating Range, gage pressure		0.3		PSI
Output Span, note 5	3.90	40	4.10	volt
Offset Voltage @ zero pressure	0.15	0.25	0.35	volt
Offset Temperature Shift (5°C-50°C), note 2			±40	mvolt
Linearity, hysteresis error, note 4			±0.5	%fs
Span Shift (5°C-50°C), note 2			±2	%span

Performance Characteristics for 1 PSI-D-4V-MINI

Parameter, note 1	Minimum	Nominal	Maximum	Units
Operating Range, differential pressure		±1.0		PSI
Output Span, note 5	±1.90	±20	±2.10	volt
Offset Voltage @ zero differential pressure	2.15	2.25	2.35	volt
Offset Temperature Shift (5°C to 50°C), note 2			±40	mvolt
Linearity, hysteresis error, note 4			±0.5	%fs
Span Shift (5°C to 50°C), note 2			±1	%span

Performance Characteristics for: 1 PSI-G-4V-MINI

Parameter, NOTE 1	Minimum	Nominal	Maximum	Units
Operating Range, gage pressure		1.0		PSI
Output Span, NOTE 5	3.90	40	4.10	volt
Offset Voltage @ zero pressure	0.15	0.25	0.35	volt
Offset Temperature Shift (5°C to 50°C), note 2			±40	mvolt
Linearity, hysteresis error, note 4			±0.5	%fs
Span Shift (5°C to 50°C), note 2			±1	%span

Performance Characteristics for: 5 PSI-D-4V-MINI

Parameter, NOTE 1	Minimum	Nominal	Maximum	Units
Operating Range, differential pressure		±5.0		PSI
Output Span, NOTE 5	±1.90	±20	±2.10	volt
Offset Voltage @ zero differential pressure	2.15	2.25	2.35	volt
Offset Temperature Shift (5°C to 50°C), note 2			±20	mvolt
Linearity, hysteresis error, note 4			±0.5	%fs
Span Shift (5°C to 50°C), note 2			±1	%span



Performance Characteristics for: 5 PSI-G-4V-MINI

Parameter, NOTE 1	Minimum	Nominal	Maximum	Units
Operating Range, gage pressure		5.0		PSI
Output Span, NOTE 5	3.90	4.0	4.10	volt
Offset Voltage @ zero pressure	0.15	0.25	0.35	volt
Offset Temperature Shift (5°C to 50°C), note 2			±20	mvolt
Linearity, hysteresis error, note 4			±0.5	%fs
Span Shift (5°C to 50°C), note 2			±1	%span

Performance Characteristics for 15 PSI-A-4V-MINI

Parameter, note 1	Minimum	Nominal	Maximum	Units
Operating Range, absolute pressure	0		15	psia
Output Span, note 5	3.90	4.0	4.10	volt
Offset Voltage @ zero pressure	0.15	0.25	0.35	volt
Offset Temperature Shift (5°C to 50°C), note 2			±20	mvolt
Linearity, hysteresis error, note 4			±0.5	%fs
Span Shift (5°C to 50°C), note 2			±1	%span

Performance Characteristics for 15 PSI-Dx-4V-MINI

Parameter, note 1	Minimum	Nominal	Maximum	Units
Operating Range, differential pressure		±15.0		PSI
Output Span, note 5	±1.90	±2.0	±2.10	volt
Offset Voltage @ zero differential pressure	2.15	2.25	2.35	volt
Offset Temperature Shift (5°C to 50°C), note 2			±20	mvolt
Linearity, hysteresis error, note 4			±0.5	%fs
Span Shift (5°C to 50°C), note 2			±1	%span

Performance Characteristics for BARO-A-4V-MINI

Parameter, note 1	Minimum	Nominal	Maximum	Units
Operating Range, absolute pressure	600		1100	mBar
Output Span, note 5	3.90	4.0	4.10	volt
Offset Voltage @ zero pressure	0.15	0.25	0.35	volt
Offset Temperature Shift (5°C to 50°C), note 2			±20	mvolt
Linearity, hysteresis error, note 4			±0.5	%fs
Span Shift (5°C to 50°C), note 2			±1	%span

Pressure Response: for any pressure applied the response time to get to 90% of pressure applied is typically less than 100 useconds.

All Sensors reserves the right to make changes to any products herein. All Sensors does not assume any liability arising out of the application or use of any product or circuit described herein, neither does it convey any license under its patent rights nor the rights of others.

Miniature Amplified Output Medium Pressure Sensor

Performance Characteristics for 15 PSI-G-4V-MINI

Parameter, note 1	Minimum	Nominal	Maximum	Units
Operating Range, gage pressure		15.0		PSI
Output Span, note 5	3.90	40	4.10	volt
Offset Voltage @ zero pressure	0.15	0.25	0.35	volt
Offset Temperature Shift (5°C to 50°C), note 2			±20	mvolt
Linearity, hysteresis error, note 4			±0.5	%fs
Span Shift (5°C to 50°C), note 2			±1	%span

Performance Characteristics for 30 PSI-Dx-4V-MINI

Parameter, note 1	Minimum	Nominal	Maximum	Units
Operating Range, differential pressure		±30.0		PSI
Output Span, note 5	±1.90	±20	±2.10	volt
Offset Voltage @ zero differential pressure	2.15	2.25	2.35	volt
Offset Temperature Shift (5°C to 50°C), note 2			±20	mvolt
Linearity, hysteresis error, note 4			±0.5	%fs
Span Shift (5°C to 50°C), note 2			±1	%span

Performance Characteristics for 30 PSI-G-4V-MINI

Parameter, note 1	Minimum	Nominal	Maximum	Units
Operating Range, gage pressure		30.0		PSI
Output Span, note 5	3.90	40	4.10	volt
Offset Voltage @ zero pressure	0.15	0.25	0.35	volt
Offset Temperature Shift (5°C to 50°C), note 2			±20	mvolt
Linearity, hysteresis error, note 4			±0.5	%fs
Span Shift (5°C to 50°C), note 2			±1	%span

Performance Characteristics for 30 PSI-A-4V-MINI

Parameter, note 1	Minimum	Nominal	Maximum	Units
Operating Range, absolute pressure		30.0		PSI
Output Span, note 5	3.90	40	4.10	volt
Offset Voltage @ zero pressure	0.15	0.25	0.35	volt
Offset Temperature Shift (5°C to 50°C), note 2			±20	mvolt
Linearity, hysteresis error, note 4			±0.5	%fs
Span Shift (5°C to 50°C), note 2			±1	%span

Specification Notes

NOTE 1: ALL PARAMETERS ARE MEASURED AT 5.0 VOLT EXCITATION, FOR THE NOMINAL FULL SCALE PRESSURE AND ROOM TEMPERATURE UNLESS OTHERWISE SPECIFIED. PRESSURE MEASUREMENTS ARE WITH POSITIVE PRESSURE APPLIED TO PORT B.

NOTE 2: SHIFT IS RELATIVE TO 25°C.

NOTE 3: SHIFT IS WITHIN THE FIRST HOUR OF EXCITATION APPLIED TO THE DEVICE.

NOTE 4: MEASURED AT ONE-HALF FULL SCALE RATED PRESSURE USING BEST STRAIGHT LINE CURVE FIT.

NOTE 5: THE VOLTAGE ADDED TO THE OFFSET VOLTAGE AT FULL SCALE PRESSURE. NOMINALLY THE OUTPUT VOLTAGE RANGE IS 0.25 TO 4.25 VOLTS FOR MINUS TO PLUS FULL SCALE PRESSURE.



BAROMETRIC AMPLIFIED PRESSURE SENSORS

600 to 1,100 mbar Barometric Pressure Sensor



Features

- Barometric Pressure Range
- Temperature Compensated
- Calibrated Zero and Span

Applications

- Medical Instrumentation
- Environmental Monitoring
- Altimeters
- Chemical Analysis

General Description

The Miniature Amplified Output pressure sensors is based upon a proprietary technology to reduce all output offset or common mode errors. This model provides a calibrated amplified output with superior output offset characteristics. Output offset errors due to change in temperature, stability to warm-up, stability to long time period, and position sensitivity are all significantly reduced when compared to conventional compensation methods. In addition the sensor utilizes a silicon, micromachined, stress concentration enhanced structure to provide a very linear output to measured pressure.

These calibrated and temperature compensated sensors give an accurate and stable output over a wide temperature range. This series is intended for use with non-corrosive, non-ionic working fluids such as air, dry gases and the like.

The output of the device is ratiometric to the supply voltage and operation from any D.C. supply voltage between 4.5 and 5.5 volts.

Physical Dimensions

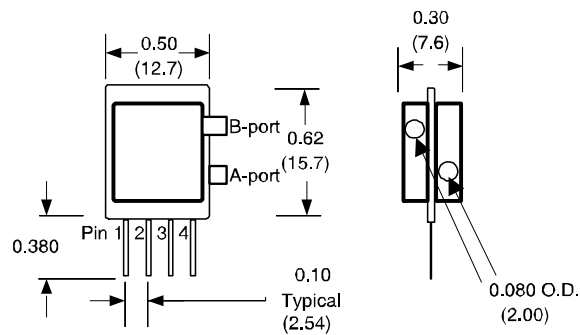

Approvals

MKT	DATE	MFG	DATE	ENG	DATE	QA	DATE
<input type="checkbox"/> As Is <input type="checkbox"/> With Change		<input type="checkbox"/> As Is <input type="checkbox"/> With Change		<input type="checkbox"/> As Is <input type="checkbox"/> With Change		<input type="checkbox"/> As Is <input type="checkbox"/> With Change	

ALL SENSORS

DS-0040 Rev C

01

Pressure Sensor Characteristics Maximum Ratings

Supply Voltage VS	+4.5 to +5.5Vdc
Lead Temperature (soldering 2-4 sec.)	250°C

Environmental Specifications

Temperature Ranges	
Compensated	see specification
Operating	-25 to 85° C
Storage	-40 to 125° C
Humidity Limits	0 to 95% RH (non condensing)

Standard Pressure Ranges

Part Number	Operating Pressure	Compensated Range
BARO-A-4V-MINI	600 to 1,100 mbar	5 to 50° C
BARO-A-4V--MINI-PRIME	600 to 1,100 mbar	-25 to 85° C
BARO-A-4V-MINI-MIL	600 to 1,100 mbar	-40 to 125° C

Equivalent Circuit

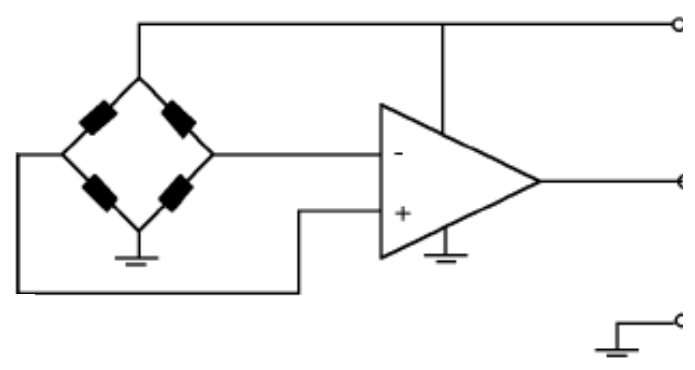

Performance Characteristics for BARO-A-4V-MINI

Parameter, note 1	Minimum	Nominal	Maximum	Units
Operating Range, absolute pressure	600		1100	mBar
Output Voltage @1,100 mbar	4.15	4.25	4.35	volt
Output Voltage @ 600 mbar	0.15	0.25	0.35	volt
Offset Temperature Shift (5°C to 50°C), note 2			±20	mvolt
Linearity, hysteresis error, note 4		0.05	0.50	%fs
Span Shift (5°C to 50°C), note 2			±1	%span

Performance Characteristics for BARO-A-4V-MINI-PRIME

Parameter, note 1	Minimum	Nominal	Maximum	Units
Operating Range, absolute pressure	600		1100	mBar
Output Voltage @1,100 mbar	4.15	4.25	4.35	volt
Output Voltage @ 600 mbar	0.15	0.25	0.35	volt
Offset Temperature Shift (-25°C to 85°C), note 2			±20	mvolt
Linearity, hysteresis error, note 4		0.05	0.50	%fs
Span Shift (-25°C to 85°C), note 2			±1	%span

Performance Characteristics for BARO-A-4V-MINI-MIL

Parameter, note 1	Minimum	Nominal	Maximum	Units
Operating Range, absolute pressure	600		1100	mBar
Output Voltage @1,100 mbar	4.15	4.25	4.35	volt
Output Voltage @ 600 mbar	0.15	0.25	0.35	volt
Offset Temperature Shift (-40°C to 125°C), note 2			±20	mvolt
Linearity, hysteresis error, note 4		0.05	0.50	%fs
Span Shift (-40°C to 125°C), note 3			±1	%span

Specification Notes

- NOTE 1: ALL PARAMETERS ARE MEASURED AT 5.0 VOLT EXCITATION, FOR THE NOMINAL FULL SCALE PRESSURE AND ROOM TEMPERATURE UNLESS OTHERWISE SPECIFIED. PRESSURE MEASUREMENTS ARE WITH POSITIVE PRESSURE APPLIED TO THE B-PORT.
- NOTE 2: SHIFT IS RELATIVE TO 25°C.
- NOTE 3: MEASURED AT ONE-HALF FULL SCALE RATED PRESSURE USING BEST STRAIGHT LINE CURVE FIT.

All Sensors reserves the right to make changes to any products herein. All Sensors does not assume any liability arising out of the application or use of any product or circuit described herein, neither does it convey any license under its patent rights nor the rights of others.

AMPLIFIED PRESSURE SENSORS

-10 cm H₂O to 120 cm H₂O Pressure Sensor



Features

- 4 Volt ratiometric output
- Temperature Compensated
- Calibrated Zero and Span

Applications

- Medical Instrumentation
- Respiratory Breathing

General Description

This Amplified Output pressure sensor is based upon a proprietary technology to compensate all errors. This model provides a calibrated amplified output with superior output characteristics. Output characteristics are tested at pressure and temperature and then digitally compensated using a proprietary 3D mapping scheme. In addition the sensor utilizes a silicon, micromachined, stress concentration enhanced structure to provide a very linear output to measured pressure.

These calibrated and temperature compensated sensors give an accurate and stable output over a wide temperature range. This series is intended for use with non-corrosive, non-ionic working fluids such as air, dry gases and the like.

The output of the device is ratiometric to the supply voltage over a supply voltage range of 4.5 to 5.5 volts.

Physical Dimensions

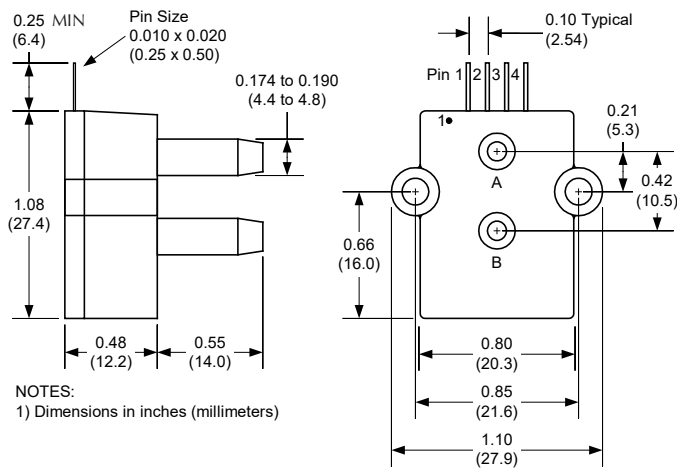

Equivalent Circuit

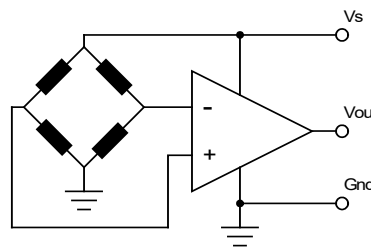

- pin 1: V_s
- pin 2: Gnd
- pin 3: V_{out}
- pin 4: do not connect

Approvals

MKT	DATE	MFG	DATE	ENG	DATE	QA	DATE
<input type="checkbox"/> As Is <input type="checkbox"/> With Change		<input type="checkbox"/> As Is <input type="checkbox"/> With Change		<input type="checkbox"/> As Is <input type="checkbox"/> With Change		<input type="checkbox"/> As Is <input type="checkbox"/> With Change	

Pressure Sensor Characteristics Maximum Ratings

Supply Voltage VS	+4.5 to +5.5 Vdc
Common-mode pressure	10 psig
Lead Temperature (soldering 2-4 sec.)	250°C

Environmental Specifications

Temperature Ranges	
Compensated	see specification
Operating	-25 to 85° C
Storage	-40 to 125° C
Humidity Limits	0 to 95% RH (non condensing)

Standard Pressure Ranges

Part Number	Operating Pressure	Compensated Range	Proof Pressure	Burst Pressure
120 CMH2O-D-4V	-10 to 120 cm H2O	5 to 50° C	300 cmH2O	600 cmH2O
120 CMH2O-D-4V-PRIME	-10 to 120 cm H2O	-25 to 85° C	300 cmH2O	600 cmH2O

Performance Characteristics for 120 CMH2O-D-4V

Parameter, note 1	Minimum	Nominal	Maximum	Units
Operating Range, pressure	-10	--	120	cmH2O
Output Voltage, @120 cmH2O	4.40	4.5	4.6	volt
Output Voltage @ zero pressure	0.30	0.35	0.40	volt
Output Voltage @-10 cmH2O	0.23	0.28	0.33	volt
Offset Temperature Shift (5°C-50°C), note 2	--	--	±1.0	%span
Linearity, hysteresis error, note 4	--	0.05	±0.25	%fs
Span Shift (5°C-50°C), note 2	--	--	±1.0	%span

Performance Characteristics for 120 CMH2O-D-4V-PRIME

Parameter, note 1	Minimum	Nominal	Maximum	Units
Operating Range, pressure	-10	--	120	cmH2O
Output Voltage, @120 cmH2O	4.40	4.5	4.6	volt
Output Voltage @ zero pressure	0.30	0.35	0.40	volt
Output Voltage @-10 cmH2O	0.23	0.28	0.33	volt
Offset Temperature Shift (-25 to 85°C), note 2	--	--	±1.0	%span
Linearity, hysteresis error, note 4	--	0.05	±0.25	%fs
Span Shift (-25 to 85°C), note 2	--	--	±1.0	%span

Specification Notes

NOTE 1: ALL PARAMETERS ARE MEASURED AT 5.0 VOLT EXCITATION, FOR THE NOMINAL FULL SCALE PRESSURE AND ROOM TEMPERATURE UNLESS OTHERWISE SPECIFIED. PRESSURE MEASUREMENTS ARE WITH POSITIVE PRESSURE APPLIED TO PORT B.

NOTE 2: SHIFT IS RELATIVE TO 25°C.

NOTE 3: SHIFT IS WITHIN THE FIRST HOUR OF EXCITATION APPLIED TO THE DEVICE.

NOTE 4: MEASURED AT ONE-HALF FULL SCALE RATED PRESSURE USING BEST STRAIGHT LINE CURVE FIT.

NOTE 5: THE VOLTAGE ADDED TO THE OFFSET VOLTAGE AT FULL SCALE PRESSURE. NOMINALLY THE OUTPUT VOLTAGE RANGE IS 0.35V TO 4.5V VOLTS FOR MINUS TO PLUS FULL SCALE PRESSURE.

All Sensors reserves the right to make changes to any products herein. All Sensors does not assume any liability arising out of the application or use of any product or circuit described herein, neither does it convey any license under its patent rights nor the rights of others.

Basic Output

BLC SERIES LOW PRESSURE COMPACT SENSORS

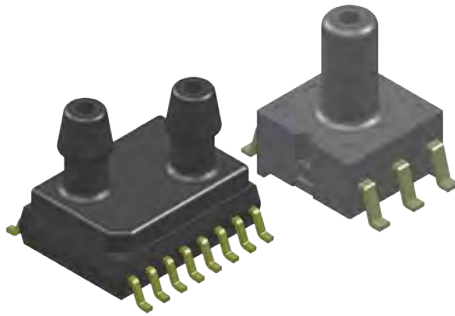

Features

- 0 to 1 inH₂O to 0 to 30 inH₂O and 15 PSIA Pressure Ranges
- uPower Low Supply Voltage (0.9V to 1.8V)
- 0.1% Linearity Typical
- Improved Front to Back Linearity
- Less Position Sensitivity
- Improved Warm-Up Shift Distribution
- Parylene Coating Available Upon Request

Applications

- Medical Instrumentation
- Environmental Controls
- HVAC
- Portable / Hand Held Devices

General Description

The BLC Series Basic Low Pressure Compact Sensor is based on All Sensors' CoBeam²™ Technology. The device provides a high output signal at a low operating voltage and reduces the overall supply voltage while maintaining comparable output levels to traditional equivalent basic sensing elements. This lower supply voltage gives rise to improved warm-up shift while the CoBeam² Technology itself reduces package stress susceptibility resulting in improved overall long term stability. The technology also vastly improves position sensitivity compared to conventional single die devices.

This series is intended for use with non-corrosive, non-ionic working fluids such as air, dry gases and the like. The output is also ratio-metric to the supply voltage and is operable from 0.9 to 1.8 volts DC.

Standard Pressure Ranges

Device	Operating Range	Proof Pressure	Burst Pressure
BLC-L01D	±1 inH ₂ O (250 Pa)	100 inH ₂ O (25 KPa)	150 inH ₂ O (37 KPa)
BLC-L05D	±5 inH ₂ O (1,250 Pa)	200 inH ₂ O (50 KPa)	300 inH ₂ O (75 KPa)
BLC-L10D	±10 inH ₂ O (2,500 Pa)	200 inH ₂ O (50 KPa)	300 inH ₂ O (75 KPa)
BLC-L20D	±20 inH ₂ O (5,000 Pa)	200 inH ₂ O (50 KPa)	500 inH ₂ O (125 KPa)
BLC-L30D	±30 inH ₂ O (7,500 Pa)	200 inH ₂ O (50 KPa)	800 inH ₂ O (200 KPa)
BLC-015A	0 to 15 PSIA (1 barA)	60 PSI (4 barA)	120 PSI (8 barA)

Pressure Sensor Maximum Ratings

Supply Voltage (Vs)	3 Vdc
Common Mode Pressure	5 psig
Lead Temperature (soldering 2-4 sec.)	270 °C

Environmental Specifications

Temperature Ranges	Operating	-25 to 85 °C
	Storage	-40 to 125 °C
Humidity Limits		0 to 95% RH (non condensing)

Performance Characteristics for BLC Series

ALL PARAMETERS ARE MEASURED AT 1.8V EXCITATION AND ROOM TEMPERATURE UNLESS OTHERWISE SPECIFIED. PRESSURE MEASUREMENTS ARE WITH POSITIVE PRESSURE APPLIED TO PORT B (THE ONLY PORT FOR THE SINGLE PORT CONFIGURATION.)

Parameter	Min	Typ	Max	Units	Notes
Output Span (FSS)					
L01D	4.5	8.0	11.5	mV	4
L05D	13.5	24.0	34.5	mV	
L10D	18.0	32.0	46.0	mV	
L20D	22.0	38.0	55.0	mV	
L30D	25.0	42.0	60.0	mV	
015A	70.0	95.0	120.0	mV	
Offset Voltage					
L01D, L05D, L10D, L20D, L30D (@ Zero Diff. Pressure)	-	-	±10.0	mV	
015A (@ 0 PSIA)	-	-	±10.0	mV	
Offset Temperature Shift (0°C-70°C)	-	±30.0	-	µV/°C	1
Offset Warm-up Shift	-	±30.0	-	µV	2, 6
Offset Position Sensitivity (1g)	-	±20.0	-	µV	-
Linearity, Hysteresis Error	-	0.10	±0.50	%FSS	3
Response Time (10% to 90% Pressure Response)	-	100	-	µS	-
Front to Back Linearity	-	0.25	-	%FSS	5
Temperature Effect on Resistance (0°C-70°C)	-	2800	-	ppm/°C	-
Temperature Effect on Span (0°C-70°C)	-	-2000	-	ppm/°C	-
Input Resistance	-	3.4	-	kΩ	-
Output Resistance	-	3.4	-	kΩ	-

Specification Notes

NOTE 1: SHIFT IS RELATIVE TO 25°C.

NOTE 2: SHIFT IS WITHIN THE FIRST HOUR OF EXCITATION APPLIED TO THE DEVICE.

NOTE 3: MEASURED AT ONE-HALF FULL SCALE RATED PRESSURE USING BEST STRAIGHT LINE CURVE FIT.

NOTE 4: THE SPAN IS THE ALGEBRAIC DIFFERENCE BETWEEN FULL SCALE OUTPUT VOLTAGE AND THE OFFSET VOLTAGE.

$$\text{Lin FB} = \left(\frac{\text{Span}_{\text{PortB}}}{\text{Span}_{\text{PortA}}} - 1 \right) \cdot 100\%$$

NOTE 5: FRONT-BACK LINERITY COMPUTED AS:

NOTE 6: TYPICAL WARM UP OF CHARACTERISTICS AS SHOWN BELOW.

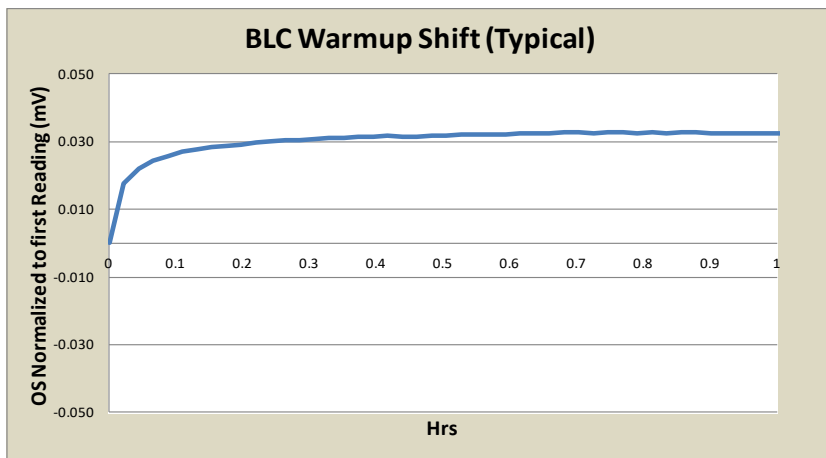

Soldering Recommendations

- 1) Solder parts as a second operation only.
- 2) Post reflow, wait for 36 hrs before performing any calibration operations.
- 3) Perform spot cleaning as necessary only by hand. DO NOT wash or submerge device in cleaning liquid.

Package Drawings

D1 Package

Pin	Definition
1	+GND
2	+Vout
3	Vs
4	N/C
5	-Vout
6	-GND

NOTES

- 1) Dimensions are in inches [mm].
- 2) For suggested pad layout, see drawing: PAD-20.
- 3) Pins 1 and 6 must be connected for Gnd.

All Sensors

TITLE: D-Series Package

SIZE: **A** FILE NAME: D1 Package

D3 Package

Pin	Definition
1	+GND
2	+Vout
3	Vs
4	N/C
5	-Vout
6	-GND

NOTES

- 1) Dimensions are in inches [mm].
- 2) For suggested pad layout, see drawing: PAD-21.
- 3) Pins 1 and 6 must be connected for Gnd.

All Sensors

TITLE: D-Series Package

SIZE: **A** FILE NAME: D3 Package

Package Drawings (Cont'd)

D4 Package

Pin	Definition
1	-Vout
2	N/C
3	N/C
4	N/C
5	GND
6	N/C
7	N/C
8	N/C
9	N/C
10	N/C
11	N/C
12	N/C
13	+Vout
14	N/C
15	N/C
16	Vs

NOTES
 1) Dimensions are in inches [mm].
 2) For suggested pad layout, see drawing: PAD-22.

All Sensors	
TITLE:	D-Series Package
SIZE	FILE NAME
A	D4 Package

Package Drawings (Cont'd)

U2 Package

NOTES

- 1) Dimensions are in inches [mm].
- 2) For suggested pad layout, see drawing: PAD-24
- 3) Pins 1 and 6 must be connected for Gnd.

Pin	Definition
1	+GND
2	+Vout
3	Vs
4	N/C
5	-Vout
6	-GND

U3 Package

NOTES

- 1) Dimensions are in inches [mm].
- 2) For suggested pad layout, see drawing: PAD-25
- 3) Pins 3 and 4 must be connected for Gnd.

Pin	Definition
1	N/C
2	-Vout
3	-GND
4	+GND
5	+Vout
6	Vs

All Sensors

TITLE:	U-Series Package	
SIZE:	FILE NAME	
A	U2 Package	

All Sensors

TITLE:	U-Series Package	
SIZE:	FILE NAME	
A	U3 Package	

Package Drawings (Cont'd)

U4 Package

Pin	Definition
1	N/C
2	+Vout
3	N/C
4	+GND
5	-GND
6	-Vout
7	N/C
8	Vs

NOTES

- 1) Dimensions are in mm [inches].
- 2) Offered for 015A only.
- 3) For suggested pad layout, see drawing: PAD-26
- 4) Pins 4 and 5 must be connected for Gnd.

All Sensors	
TITLE:	U-Series Package
SIZE	FILE NAME
A	U4 Package

How To Order

Refer to Table 1 for configuring a standard base part number which includes the pressure range and package.

Example P/N with options: BLC-L01D-D1

Table 1 - How to Configure a Part Number

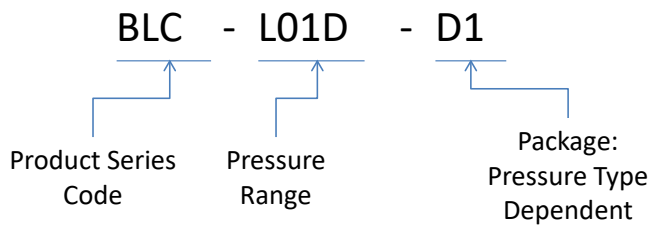

Where:

Pressure Range (D1, D3, D4 Packages — Differential Only): L01D, L05D, L10D, L20D, L30D

Pressure Range (U2, U3 Package — Gage Only): L01D, L05D, L10D, L20D, L30D

Pressure Range (U4 Package — Absolute Only): 015A

(Consult with factory for parylene coating)

BLC SERIES LOW PRESSURE COMPACT SENSORS

Suggested Pad Layout

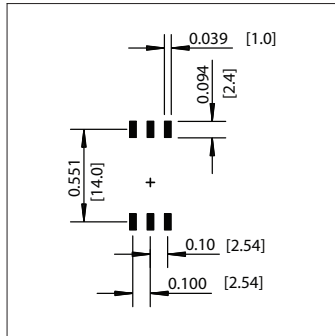

PAD-20

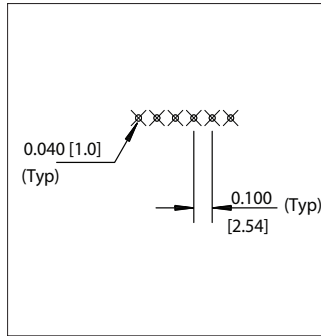

PAD-21

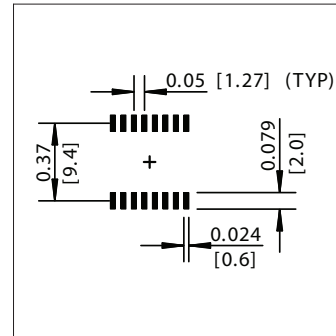

PAD-22

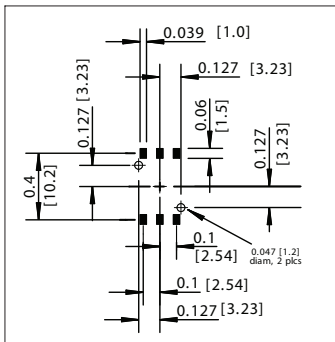

PAD-24

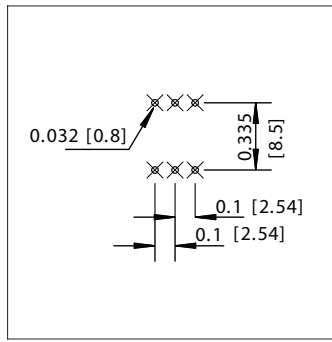

PAD-25

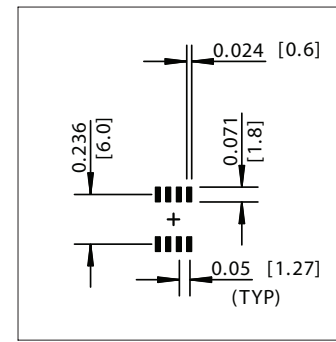

PAD-26

Dimensions are in inches [mm].

All Sensors reserves the right to make changes to any products herein. All Sensors does not assume any liability arising out of the application or use of any product or circuit described herein, neither does it convey any license under its patent rights nor the rights of others.

Performance Characteristics for BLCR Series

ALL PARAMETERS ARE MEASURED AT 3.3 VOLT EXCITATION AND ROOM TEMPERATURE UNLESS OTHERWISE SPECIFIED. PRESSURE MEASUREMENTS ARE WITH POSITIVE PRESSURE APPLIED TO PORT B (THE ONLY PORT FOR THE SINGLE PORT CONFIGURATION).

Parameter	Min	Typ	Max	Units	Notes
Output Span (FSS)					4
L01D	4.5	8.0	11.5	mV	
L05D	13.5	24.0	34.5	mV	
L10D	18.0	32.0	46.0	mV	
L20D	22.0	38.0	55.0	mV	
L30D	25.0	42.0	60.0	mV	
Offset Voltage @ Zero Diff. Pressure	-	-	±10.0	mV	-
Offset Temperature Shift (0°C-70°C)	-	±4.0	-	µV/°C	1
Offset Warm-up Shift	-	±10.0	-	µV	2, 6
Offset Position Sensitivity (1g)	-	±0.2	-	µV	-
Linearity, Hysteresis Error	-	0.1	±0.5	%FSS	3
Response Time (10% to 90% Pressure Response)	-	100.0	-	µS	-
Front to Back Linearity	-	0.25	-	%FSS	5
Temperature Effect on Resistance (0°C-70°C)	-	2800	-	ppm/°C	-
Temperature Effect on Span (0°C-70°C)	-	-2000	-	ppm/°C	-
Input Resistance	-	1.7	-	kΩ	-
Output Resistance	-	1.7	-	kΩ	-

Specification Notes

NOTE 1: SHIFT IS RELATIVE TO 25°C.

NOTE 2: SHIFT IS WITHIN THE FIRST HOUR OF EXCITATION APPLIED TO THE DEVICE.

NOTE 3: MEASURED AT ONE-HALF FULL SCALE RATED PRESSURE USING BEST STRAIGHT LINE CURVE FIT.

NOTE 4: THE SPAN IS THE ALGEBRAIC DIFFERENCE BETWEEN FULL SCALE OUTPUT VOLTAGE AND THE OFFSET VOLTAGE.

NOTE 5: FRONT-BACK LINEARITY COMPUTED AS:
$$Lin_{FB} = \left(\frac{Span_{PortB}}{Span_{PortA}} - 1 \right) \cdot 100\%$$

NOTE 6: TYPICAL WARM UP CHARACTERISTICS AS SHOWN BELOW.

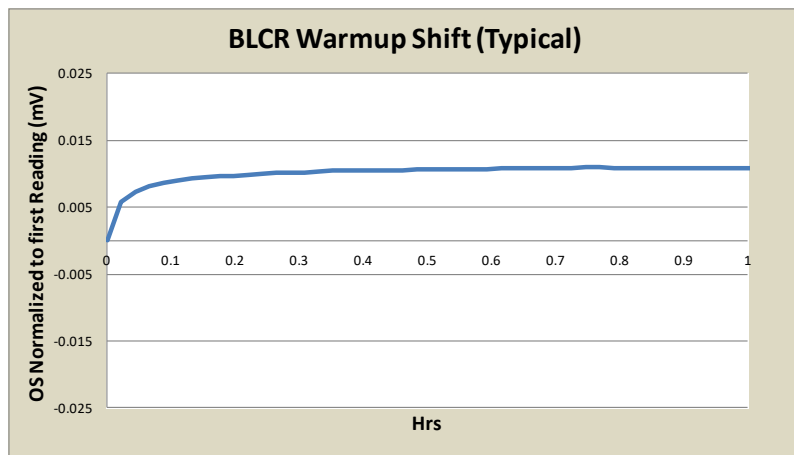

Soldering Recommendations

- 1) Solder parts as a second operation only.
- 2) Post reflow, wait for 36 hrs before performing any calibration operations.
- 3) Perform spot cleaning as necessary only by hand. DO NOT wash or submerge device in cleaning liquid.

Package Drawings

D1 Package

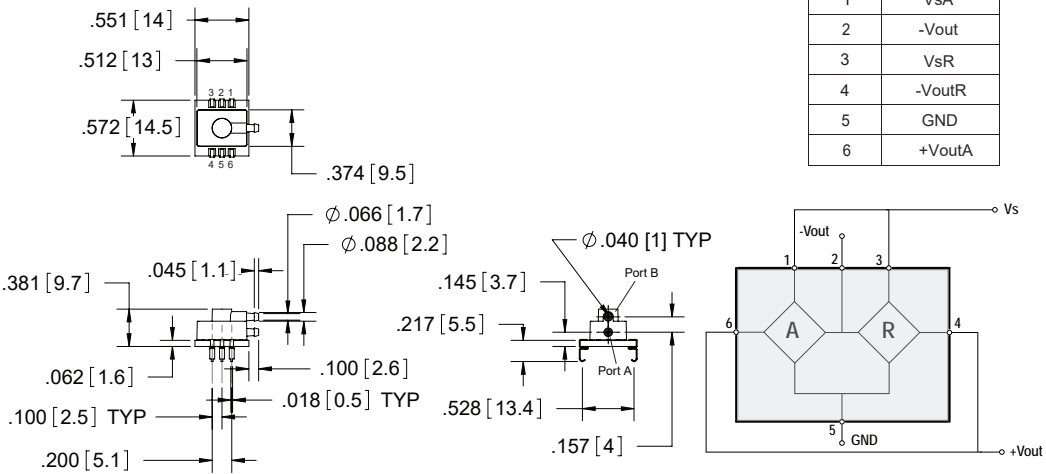

NOTES

- 1) Dimensions are in inches [mm].
- 2) Pins 1 & 3 must be connected for Vs input.
- 3) Pins 4 & 6 must be connected for +Vout output.
- 4) For suggested pad layout, see drawing: PAD-20.

All Sensors

TITLE:	D-Series Package
SIZE	FILE NAME
A	D1 Package

D3 Package

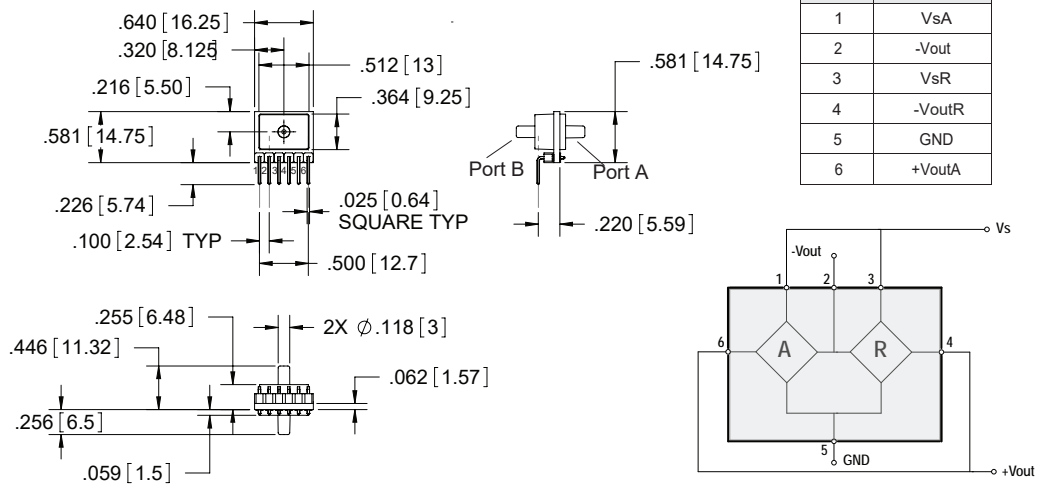

NOTES

- 1) Dimensions are in inches [mm].
- 2) Pins 1 & 3 must be connected for Vs input.
- 3) Pins 4 & 6 must be connected for +Vout output.
- 4) For suggested pad layout, see drawing: PAD-21.

All Sensors

TITLE:	D-Series Package
SIZE	FILE NAME
A	D3 Package

Package Drawings (Cont'd)

D4 Package

Top view dimensions: .104 [2.6], .102 [2.6], .209 [5.3], .050 [1.3] TYP, .350 [8.9], .016 [0.4] TYP, $\phi .039 [1]$, PIN 1, .098 [2.5], $\phi .118 [3]$, $\phi .087 [2.2]$, .142 [3.6], .093 [2.4], .032 [0.8], .407 [10.3], .296 [7.5], .197 [5].

Pin	Definition
1	-OutA
2	N/C
3	N/C
4	N/C
5	GndA
6	-OutR
7	GndR
8	N/C
9	N/C
10	+OutR
11	N/C
12	+VsR
13	+OutA
14	N/C
15	N/C
16	+VsA

NOTES
 1) Dimensions are in inches [mm].
 2) Pins 12 and 16 must be connected for Vs input.
 3) Pins 5 and 7 must be connected for Gnd.
 4) Pins 1 and 10 must be connected for -Vout.
 5) Pins 6 and 13 must be connected for +Vout.
 6) For suggested pad layout, see drawing: PAD-22.

All Sensors	
TITLE:	D-Series Package
SIZE:	FILE NAME
A	D4 Package

Package Drawings (Cont'd)

U1 Package

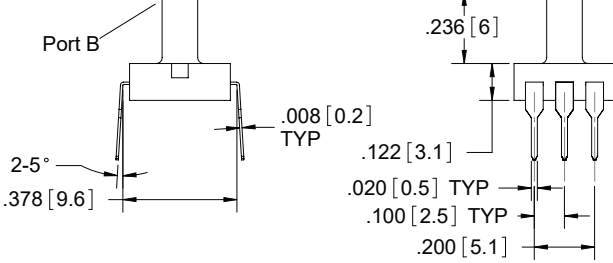
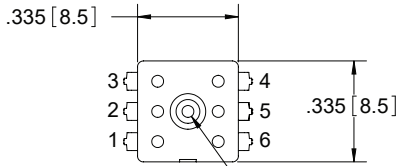

Pin	Definition
1	VsA
2	-Vout
3	VsR
4	-VoutR
5	GND
6	+VoutA

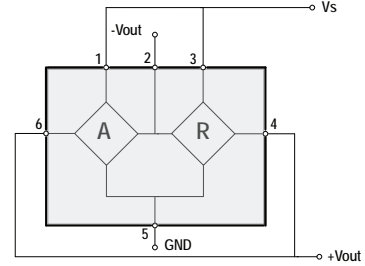

NOTES

- 1) Dimensions are in inches [mm].
- 2) Pins 1 & 3 must be connected for Vs input.
- 3) Pins 4 & 6 must be connected for +Vout output.
- 4) For suggested pad layout, see drawing: PAD-23.

All Sensors

TITLE: U-Series Package

SIZE: A FILE NAME: U1 Package

U2 Package

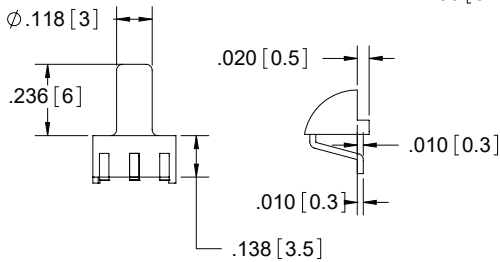
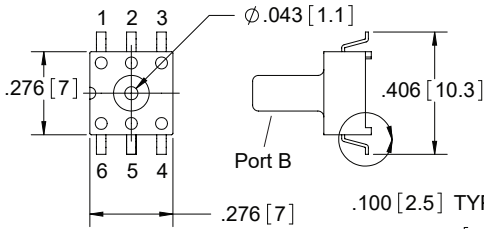

Pin	Definition
1	VsA
2	-Vout
3	VsR
4	-VoutR
5	GND
6	+VoutA

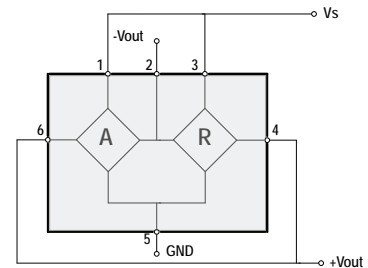

NOTES

- 1) Dimensions are in inches [mm].
- 2) Pins 1 & 3 must be connected for Vs input.
- 3) Pins 4 & 6 must be connected for +Vout output.
- 4) For suggested pad layout, see drawing: PAD-24

All Sensors

TITLE: U-Series Package

SIZE: A FILE NAME: U2 Package

How To Order

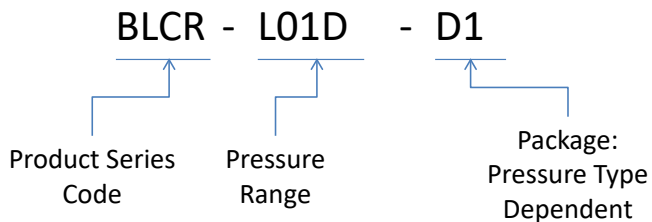

Where:

Pressure Range (D1, D3, D4 Packages — Differential Only): L01D, L05D, L10D, L20D, L30D

Pressure Range (U1, U2 Package — Gage Only): L01D, L05D, L10D, L20D, L30D

(Consult with factory for parylene coating)

Packaging

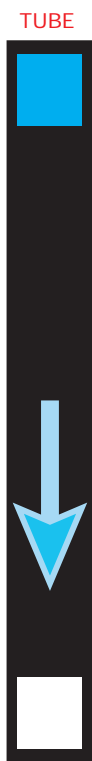

ALL PRODUCTS FOUND IN THIS DATASHEET ARE PACKAGED IN TUBES WITH PIN 1 ORIENTED TOWARDS THE WHITE STOPPER.

Product Identification (on backside of device)

 All Sensors	— Company
BLCR-L01D-D1	— Part Number
B12399-09	— Wafer Number
R16A24-14	— Lot Number

Example shown above.

Pressure Tubing Recommendations

Tubing Number	Part Number	Description
1	ABX00002	Versilic SPX-50, 1/16" I.D. x 1/8" O.D. x 1/32" Wall
2	ABX00004	Versilic SPX-50, 3/32" I.D. x 5/32" O.D. x 1/32" Wall

Package	Tubing Number
D1	1
D3	2
D4	1
U1	2
U2	2

Suggested Pad Layout

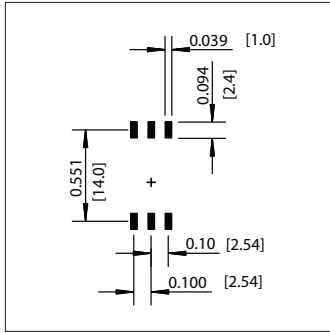

PAD-20

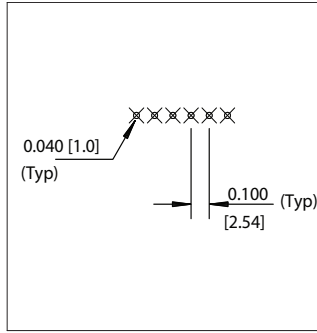

PAD-21

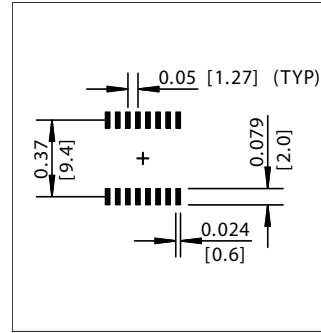

PAD-22

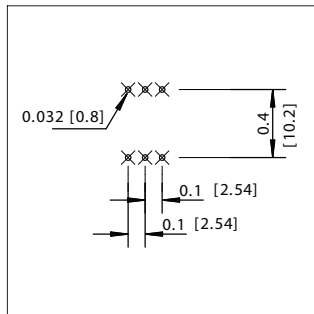

PAD-23

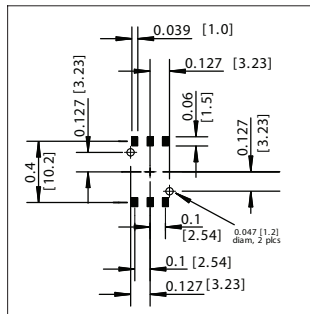

PAD-24

Dimensions are in inches [mm].

All Sensors reserves the right to make changes to any products herein. All Sensors does not assume any liability arising out of the application or use of any product or circuit described herein, neither does it convey any license under its patent rights nor the rights of others.

BLV SERIES LOW VOLTAGE PRESSURE SENSORS



Features

- 0 to 1 "H₂O to 0 to 30 "H₂O Pressure Ranges
- uPower Low Supply Voltage (0.9V to 1.8V)
- 90% Less Power Than Mini-Basic Series
- 0.3% Linearity
- Improved Front to Back Linearity
- Excellent Position Sensitivity
- Improved Warm-Up Shift Distribution
- Parylene Coating Available Upon Request

Applications

- Medical Instrumentation
- Environmental Controls
- HVAC
- Portable / Hand Held Devices

General Description

The BLV Series Basic Sensor is based on All Sensors' CoBeam²™ Technology. The device provides a high output signal at a low operating voltage and reduces the overall supply voltage while maintaining comparable output levels to traditional equivalent basic sensing elements. This lower supply voltage gives rise to improved warm-up shift while the CoBeam² Technology itself reduces package stress susceptibility resulting in improved overall long term stability. The technology also vastly improves position sensitivity compared to conventional single die devices.

This series is intended for use with non-corrosive, non-ionic working fluids such as air, dry gases and the like. The output is also ratiometric to the supply voltage and is operable from 0.9 to 1.8 volts DC.

Standard Pressure Ranges				Equivalent Circuit	
Device	Operating Range	Proof Pressure	Burst Pressure		
BLV-L01D	±1 inH ₂ O	100 inH ₂ O	300 inH ₂ O		
BLV-L05D	±5 inH ₂ O	200 inH ₂ O	300 inH ₂ O		
BLV-L10D	±10 inH ₂ O	200 inH ₂ O	300 inH ₂ O		
BLV-L20D	±20 inH ₂ O	200 inH ₂ O	500 inH ₂ O		
BLV-L30D	±30 inH ₂ O	200 inH ₂ O	800 inH ₂ O		
Pressure Sensor Maximum Ratings			Environmental Specifications		
Supply Voltage (Vs)	6 Vdc		Temperature Ranges	-25 to 85 °C	
Common Mode Pressure	5 psig		Operating	-40 to 125 °C	
Lead Temperature (soldering 2-4 sec.)	270 °C		Storage	(non condensing)	
			Humidity Limits	0 to 95% RH	

Approvals

MKT	DATE	MFG	DATE	ENG	DATE	QA	DATE
<input type="checkbox"/> As Is <input type="checkbox"/> With Change		<input type="checkbox"/> As Is <input type="checkbox"/> With Change		<input type="checkbox"/> As Is <input type="checkbox"/> With Change		<input type="checkbox"/> As Is <input type="checkbox"/> With Change	

ALL SENSORS

DS-0275 REV A

Performance Characteristics for BLV Series

ALL PARAMETERS ARE MEASURED AT 1.8 VOLT EXCITATION AND ROOM TEMPERATURE UNLESS OTHERWISE SPECIFIED. PRESSURE MEASUREMENTS ARE WITH POSITIVE PRESSURE APPLIED TO PORT B (THE ONLY PORT FOR THE SINGLE PORT CONFIGURATION).

Parameter	Min	Typ	Max	Units	Notes
Output Span					
L01D @ 1 inH2O	4.5	8.0	11.5	mV	4
L05D @ 5 inH2O	13.5	24.0	34.5	mV	4
L10D @ 10 inH2O	18.0	32.0	46.0	mV	4
L20D @ 20 inH2O	22.0	38.0	55.0	mV	4
L30D @ 30 inH2O	25.0	42.0	60.0	mV	4
Offset Voltage @ Zero Diff. Pressure	-	-	±10	mV	-
Offset Temperature Shift (0°C-70°C)	-	-25.0	-	µV/°C	1
Offset Warm-up Shift	-	±20.0	±100	µV	2
Offset Position Sensitivity (1g)	-	±20.0	-	µV	-
Offset Long Term Drift (One Year)	-	±120	-	µV	-
Linearity, Hysteresis Error	-	0.10	±0.30	%FSS	3
Response Time (10% to 90% Pressure Response)	-	100	-	µS	-
Front to Back Linearity	-	0.25	-	%FSS	5
Temperature Effect on Resistance (0°C-70°C)	-	2800	-	ppm/°C	-
Temperature Effect on Span (0°C-70°C)	-	-1900	-	ppm/°C	-
Input Resistance	-	3.0	-	k ohm	-
Output Resistance	-	3.0	-	k ohm	-

Specification Notes

NOTE 1: SHIFT IS RELATIVE TO 25°C.

NOTE 2: SHIFT IS WITHIN THE FIRST HOUR OF EXCITATION APPLIED TO THE DEVICE.

NOTE 3: MEASURED AT ONE-HALF FULL SCALE RATED PRESSURE USING BEST STRAIGHT LINE CURVE FIT.

NOTE 4: THE SPAN IS THE ALGEBRAIC DIFFERENCE BETWEEN FULL SCALE OUTPUT VOLTAGE AND THE OFFSET VOLTAGE.

NOTE 5: FRONT-BACK LINEARITY COMPUTED AS: $Lin_{FB} = \left(\frac{Span_{Front}}{Span_{Back}} - 1 \right) \cdot 100\%$

How To Order

BLV---

Series

Option	Description
L01D	1 inH2O
L05D	5 inH2O
L10D	10 inH2O
L20D	20 inH2O
L30D	30 inH2O

Package

Option	Description
B1NS	Two Ports Same Direction
B2NS	Two Ports Opposite Direction
BGNS	One Port

Coating

Option	Description
N	No Coating
P	Parylene Coating

(Consult with factory for parylene coating)

Example: BLV-L10D-B1NS-N

BLV SERIES LOW VOLTAGE PRESSURE SENSORS

Suggested Pad Layout

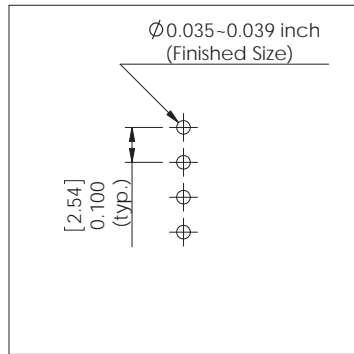

PAD-01

Package Characteristics

Package ID	Approximate Port Volume			Weight	Units
	Port A	Port B	Units		
B1NS	181	176	mm ³	1.2	Grams
B2NS	181	176	mm ³	1.2	Grams
BGNS	1.5	176	mm ³	0.9	Grams

Product Labeling

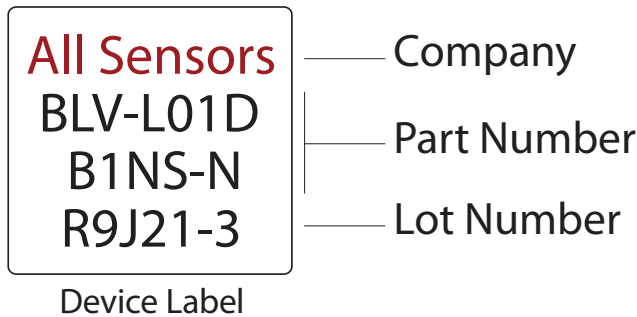

All Sensors reserves the right to make changes to any products herein. All Sensors does not assume any liability arising out of the application or use of any product or circuit described herein, neither does it convey any license under its patent rights nor the rights of others.

BLV SERIES LOW VOLTAGE PRESSURE SENSORS

BLVR SERIES LOW VOLTAGE PRESSURE SENSORS



Features

- 0 to 1 "H₂O to 0 to 30 "H₂O Pressure Ranges
- Low Supply Voltage (1.8V to 3.3V)
- 40% Less Power Than Mini-Basic Series
- 0.3% Linearity
- Improved Front to Back Linearity
- Offset Compensated
- Superior Position Sensitivity
- Improved Warm-Up Shift Distribution
- Parylene Coating Available Upon Request

Applications

- Medical Instrumentation
- Environmental Controls
- HVAC
- Portable / Hand Held Devices

General Description

The BLVR Series Basic Sensor is based on a Dual Die Reference technology to reduce all output offset or common mode errors. It also incorporates All Sensors CoBeam²™ Technology to reduce the overall supply voltage while maintaining comparable output levels to traditional equivalent basic sensing elements. This lower supply voltage gives rise to improved warm-up shift while the CoBeam² Technology itself reduces package stress susceptibility resulting in improved overall long term stability. The technology also vastly improves position sensitivity to nearly unmeasurable levels.

This series is intended for use with non-corrosive, non-ionic working fluids such as air, dry gases and the like. The output is also ratiometric to the supply voltage and is operable from 1.8 to 3.3 volts DC.

Standard Pressure Ranges				Equivalent Circuit
Device	Operating Range	Proof Pressure	Burst Pressure	
BLVR-L01D	±1 inH ₂ O	100 inH ₂ O	300 inH ₂ O	
BLVR-L05D	±5 inH ₂ O	200 inH ₂ O	300 inH ₂ O	
BLVR-L10D	±10 inH ₂ O	200 inH ₂ O	300 inH ₂ O	
BLVR-L20D	±20 inH ₂ O	200 inH ₂ O	500 inH ₂ O	
BLVR-L30D	±30 inH ₂ O	200 inH ₂ O	800 inH ₂ O	

Pressure Sensor Maximum Ratings		Environmental Specifications	
Supply Voltage (Vs)	6 Vdc	Temperature Ranges	
Common Mode Pressure	5 psig	Operating	-25 to 85 °C
Lead Temperature (soldering 2-4 sec.)	270 °C	Storage	-40 to 125 °C
		Humidity Limits	0 to 95% RH (non condensing)

Approvals

MKT	DATE	MFG	DATE	ENG	DATE	QA	DATE
<input type="checkbox"/> As Is <input type="checkbox"/> With Change		<input type="checkbox"/> As Is <input type="checkbox"/> With Change		<input type="checkbox"/> As Is <input type="checkbox"/> With Change		<input type="checkbox"/> As Is <input type="checkbox"/> With Change	

ALL SENSORS

DS-0280 Rev A

Performance Characteristics for BLVR Series

ALL PARAMETERS ARE MEASURED AT 3.3 VOLT EXCITATION AND ROOM TEMPERATURE UNLESS OTHERWISE SPECIFIED. PRESSURE MEASUREMENTS ARE WITH POSITIVE PRESSURE APPLIED TO PORT B (THE ONLY PORT FOR THE SINGLE PORT CONFIGURATION).

Parameter	Min	Typ	Max	Units	Notes
Output Span					
L01D @ 1 inH2O	4.5	8.0	11.5	mV	4
L05D @ 5 inH2O	13.5	24.0	34.5	mV	4
L10D @ 10 inH2O	18.0	32.0	46.0	mV	4
L20D @ 20 inH2O	22.0	38.0	55.0	mV	4
L30D @ 30 inH2O	25.0	42.0	60.0	mV	4
Offset Voltage @ Zero Diff. Pressure	-	-	±8.0	mV	-
Offset Temperature Shift (0°C-70°C)	-	±0.1	-	mV	1
Offset Warm-up Shift	-	±10	±80	uV	2
Offset Position Sensitivity (1g)	-	±0.2	-	uV	-
Offset Long Term Drift (One Year)	-	±80	-	uV	-
Linearity, Hysteresis Error	-	0.1	±0.3	%FSS	3
Response Time (10% to 90% Pressure Response)	-	100	-	uS	-
Front to Back Linearity	-	0.25	-	%FSS	5
Temperature Effect on Resistance (0°C-70°C)	-	2800	-	ppm/°C	-
Temperature Effect on Span (0°C-70°C)	-	-1900	-	ppm/°C	-
Input Resistance	-	1.5	-	k ohm	-
Output Resistance	-	1.5	-	k ohm	-

Specification Notes

NOTE 1: SHIFT IS RELATIVE TO 25°C.

NOTE 2: SHIFT IS WITHIN THE FIRST HOUR OF EXCITATION APPLIED TO THE DEVICE.

NOTE 3: MEASURED AT ONE-HALF FULL SCALE RATED PRESSURE USING BEST STRAIGHT LINE CURVE FIT.

NOTE 4: THE SPAN IS THE ALGEBRAIC DIFFERENCE BETWEEN FULL SCALE OUTPUT VOLTAGE AND THE OFFSET VOLTAGE.

NOTE 5: FRONT-BACK LINEARITY COMPUTED AS:
$$\text{Lin}_{FB} = \left(\frac{\text{Span}_{\text{Front}}}{\text{Span}_{\text{Back}}} - 1 \right) \cdot 100\%$$

How To Order

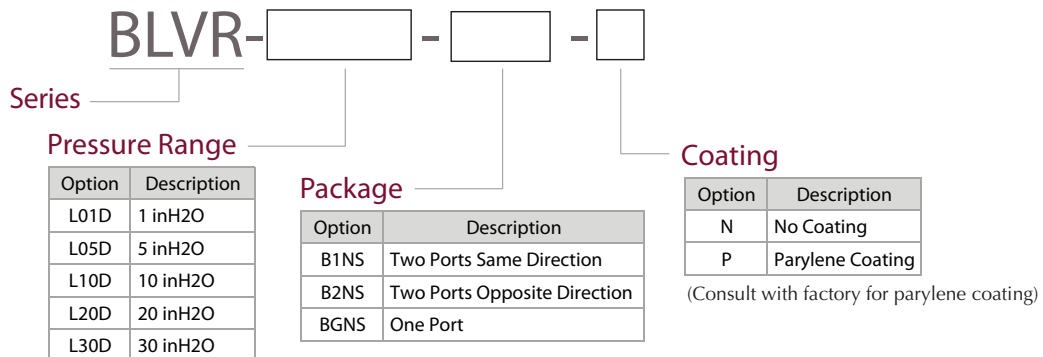

Example: BLVR-L10D-B1NS-N

BLVR SERIES LOW VOLTAGE PRESSURE SENSORS

Suggested Pad Layout

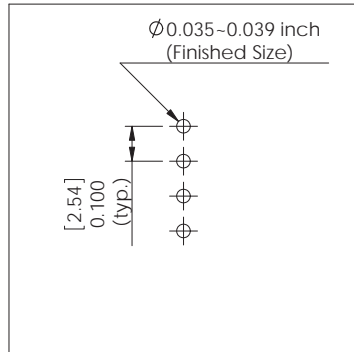

PAD-01

Package Characteristics

Package ID	Approximate Port Volume			Weight	Units
	Port A	Port B	Units		
B1NS	181	173	mm ³	1.2	Grams
B2NS	181	173	mm ³	1.2	Grams
BGNS	1.5	173	mm ³	0.9	Grams

Product Labeling

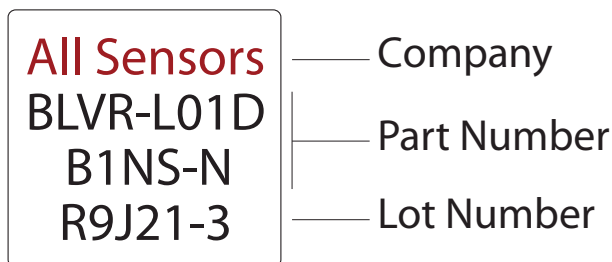

Device Label

All Sensors reserves the right to make changes to any products herein. All Sensors does not assume any liability arising out of the application or use of any product or circuit described herein, neither does it convey any license under its patent rights nor the rights of others.

BLVR SERIES LOW VOLTAGE PRESSURE SENSORS

BDS SERIES PRESSURE SENSOR



Features

- Dual Sensing Elements (Absolute & Differential)
- Top constraint absolute sensing element for helium applications
- Parylene coating available upon request
- RoHS Compliant

Applications

- Gas Flow Measurement

General Description

The BDS Basic Pressure Sensor was designed with the idea of combining two sensing elements into one package. This sensor is designed to provide a precise flow measurement by combining a differential and absolute sensing element in the same package. By combining the differential and absolute sensing element, engineers can save cost and space in today's smaller devices.

The BASIC series pressure sensors are based upon a proprietary technology to reduce the size of the sensor and yet maintain a high level of performance. Output offset errors due to position sensitivity; packaging stress and long term drift are all significantly reduced when compared to conventional silicon sensors. In addition, the sensor utilizes a silicon, micromachined, stress concentration enhanced structure to provide a very linear output to measured pressure.

This series is intended for use with non-corrosive, non-ionic working fluids such as air, dry gases and the like.

The output of the device is ratiometric to the supply voltage.

Physical Dimensions

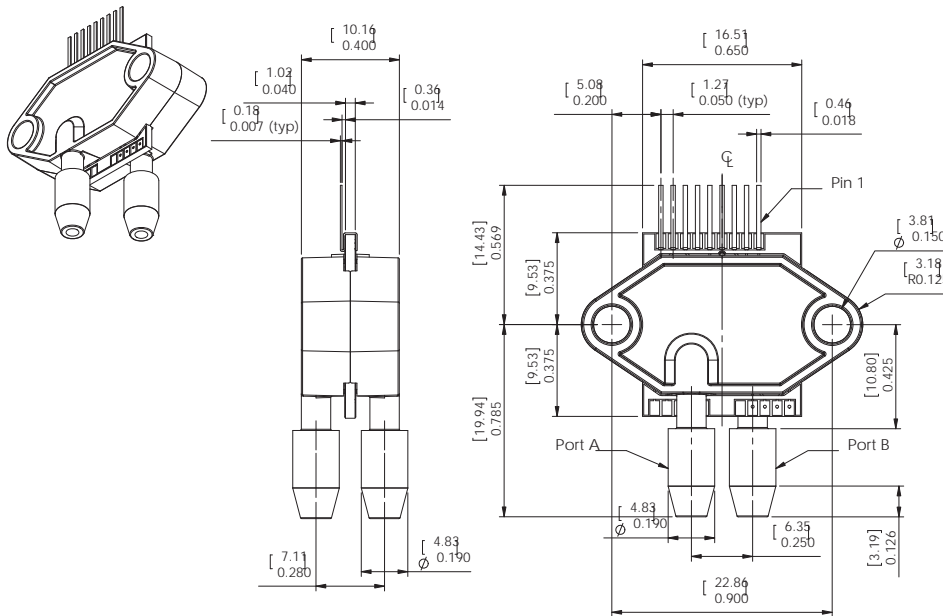

PINOUT

- Pin 1: DP_Gnd +
- Pin 2: DP_Gnd -
- Pin 3: DP_+Out
- Pin 4: AP_Gnd
- Pin 5: DP_Vs
- Pin 6: AP_-Out
- Pin 7: DP_-Out
- Pin 8: AP_Vs
- Pin 9: AP_+Out

Approvals

MKT	DATE	MFG	DATE	ENG	DATE	QA	DATE
<input type="checkbox"/> As Is <input type="checkbox"/> With Change		<input type="checkbox"/> As Is <input type="checkbox"/> With Change		<input type="checkbox"/> As Is <input type="checkbox"/> With Change		<input type="checkbox"/> As Is <input type="checkbox"/> With Change	

Pressure Sensor Characteristics Maximum Ratings

Supply Voltage VS	6 Vdc
Lead Temperature (soldering 2-4 sec.)	270°C

Equivalent Circuit

Environmental Specifications

Temperature Ranges	
Operating	-25 to 85° C
Storage	-40 to 125° C
Humidity Limits	0 to 95% RH (non condensing)

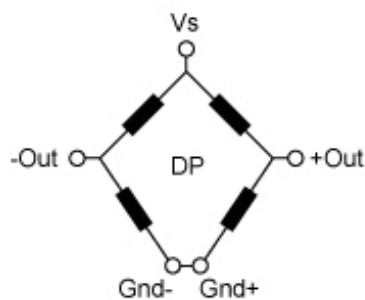

Differential Sensor (DP)

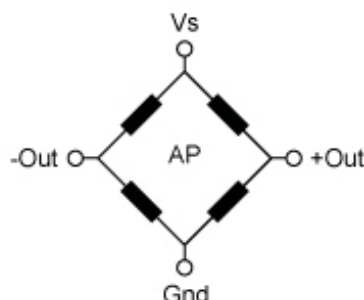

Absolute Sensor (AP)

Standard Pressure Range

Device Type	Operating Pressure	Nominal	Sensitivity ⁽¹⁾		Proof Pressure	Burst Pressure
			Std Dev.	Units		
BDS-L10D030A	--	--	--	--	--	--
Absolute	0 - 30 PSIA	7.5	±1.25	mV/PSI	90 PSI	150 PSI
Differential	0 - 10 inH2O	3.0	±0.40	mV/inH2O	15 PSI	30 PSI
BDS-L10D100A	--	--	--	--	--	--
Absolute	0 - 100 PSIA	3.0	±0.28	mV/PSI	150 PSI	150 PSI
Differential	0 - 10 inH2O	3.0	±0.40	mV/inH2O	15 PSI	30 PSI

Performance Characteristic: BDS-L10D030A Absolute Element

Parameter ⁽¹⁾	Minimum	Nominal	Maximum	Units
Offset Voltage (@1 atm)	+25	--	+125	mv
Temperature Effect on Offset ⁽²⁾	--	±3	--	uV/V/°C
Temperature Effect on Resistance ^(2,5)	1700	2600	3100	ppm/°C
Temperature Effect on Span ^(2,5)	-1500	-1900	-2400	ppm/°C
Linearity error ^(4,5)	--	±0.2	±0.5	% FSS
Hysteresis error	--	±0.01	--	% FSS
Input Resistance	2.0	2.5	3.0	kohms
Output Resistance	2.0	2.5	3.0	kohms
Long term stability ⁽³⁾	--	0.1	--	% FSS

Differential Element

Parameter ⁽¹⁾	Minimum	Nominal	Maximum	Units
Offset Voltage	--	±5.0	±25.0	mv
Temperature Effect on Offset ⁽²⁾	--	±3.0	--	uV/V/°C
Temperature Effect on Resistance ^(2,5)	2300	2600	3300	ppm/°C
Temperature Effect on Span ^(2,5)	-1700	-2200	-2700	ppm/°C
Linearity error ^(4,5)	--	±0.5	1.0	% FSS
Hysteresis error	--	±0.01	--	% FSS
Position Sensitivity ⁽⁵⁾	--	±0.01	±0.03	% FSS
Warm Up Shift	--	±10.0	--	uV
Input Resistance	1.3	1.6	2.5	kohms
Output Resistance	1.3	1.6	2.5	kohms
Long term stability ⁽³⁾	--	0.1	--	% FSS

Performance Characteristic: BDS-L10D100A

Absolute Element

Parameter ⁽¹⁾	Minimum	Nominal	Maximum	Units
Offset Voltage (@1 atm)	-20.0	--	+120	mv
Temperature Effect on Offset ⁽²⁾	--	±3.0	--	uV/V/°C
Temperature Effect on Resistance ^(2,5)	1200	2600	3100	ppm/°C
Temperature Effect on Span ^(2,5)	-1500	-1900	-2400	ppm/°C
Linearity error ^(4,5)	--	±0.2	±0.5	% FSS
Hysteresis error	--	±0.01	--	% FSS
Input Resistance	2.0	2.5	3.0	kohms
Output Resistance	2.0	2.5	3.0	kohms
Long term stability ⁽³⁾	--	0.1	--	% FSS

Differential Element

Parameter ⁽¹⁾	Minimum	Nominal	Maximum	Units
Offset Voltage	--	±5.0	±25.0	mv
Temperature Effect on Offset ⁽²⁾	--	±3.0	--	uV/V/°C
Temperature Effect on Resistance ^(2,5)	2300	2600	3300	ppm/°C
Temperature Effect on Span ^(2,5)	-1700	-2200	-2700	ppm/°C
Linearity error ^(4,5)	--	±0.5	±1.0	% FSS
Hysteresis error	--	±0.01	--	% FSS
Position Sensitivity ⁽⁵⁾	--	±0.01	±0.03	% FSS
Warm Up Shift	--	±10	--	uV
Input Resistance	1.3	1.6	2.5	kohms
Output Resistance	1.3	1.6	2.5	kohms
Long term stability ⁽³⁾	--	0.1	--	% FSS



Ordering Information

Part Number	Configuration		
	<u>Differential</u>	<u>Absolute</u>	
	<u>Sensor</u>	<u>Sensor</u>	<u>Package</u>
BDS-L10D030A-N9	10 inH2O	30 PSIA	N9
BDS-L10D100A-N9	10 inH2O	100 PSIA	N9

Specification Notes

- NOTE 1: ALL PARAMETERS ARE MEASURED AT 5.0 VOLT EXCITATION, FOR THE NOMINAL FULL SCALE PRESSURE AND ROOM TEMPERATURE UNLESS OTHERWISE SPECIFIED. PRESSURE MEASUREMENTS ARE WITH POSITIVE PRESSURE TO PORT B.
- NOTE 2: SHIFT IS RELATIVE TO 25°C.
- NOTE 3: SHIFT IS WITHIN THE FIRST YEAR OF OPERATION.
- NOTE 4: MEASURED AT ONE-HALF FULL SCALE RATED PRESSURE USING BEST STRAIGHT LINE CURVE FIT.
- NOTE 5: PARAMETER IS CHARACTERIZED AND NOT 100% TESTED. MINIMUM AND MAXIMUM VALUES INDICATED AS A DESIGN REFERENCE.

All Sensors reserves the right to make changes to any products herein. All Sensors does not assume any liability arising out of the application or use of any product or circuit described herein, neither does it convey any license under its patent rights nor the rights of others.

Media Isolated Sensors (Millivolt)

CPM 502

Piezoresistive ceramic pressure sensor with flush membrane

- Excellent chemical resistance
- Easy mounting
- Pressure ranges
7.5 to 750 psi gauge, absolute
1500 to 9000 psi sealed gauge

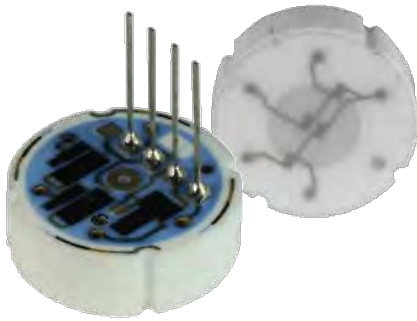

Standard Pressure Ranges

PSI ¹⁾	bar	Proof pressure		Admissible negative pressure		Burst pressure		Output signal	Sensor thickness
		[PSI ¹⁾ / bar]	[PSI ¹⁾ / bar]	[PSI ¹⁾ / bar]	[PSI ¹⁾ / bar]	[PSI ¹⁾ / bar]	[mV/V]	[mm]	
7.5 ²⁾	0.5 ²⁾	15	1	- 0.15	-2	30	2	1.4 to 2.4	6.15
15	1	30	2	- 0.20	-3	45	3	2.0 to 3.6	6.17
30	2	60	4	- 0.40	-6	90	6	2.0 to 3.5	6.23
75	5	150	10	- 0.80	-11.5	180	12	2.3 to 4.0	6.30
150	10	225	15	vacuum resistant		300	20	3.4 to 6.0	6.35
300	20	525	35			750	50	2.4 to 4.0	6.55
750	50	1500	100			1800	120	4.0 to 6.0	6.70
1500 ³⁾	100 ³⁾	2250	150			3000	200	3.0 to 4.8	6.70
3000 ³⁾	200 ³⁾	5250	350			7500	500	2.5 to 3.9	7.05
6000 ³⁾	400 ³⁾	7500	500			9750	650	3.1 to 4.8	7.32
9000 ³⁾	600 ³⁾	11250	750			14250	950	3.1 to 4.8	7.55

Reference Conditions

Supply voltage	2 to 30 V _{DC} stabilized (I _{max} = 4 mA)
Bridge resistance	11 kΩ ± 30 %
Reference temperature	25 °C
Measuring supply voltage	10 V _{DC}

Performance Characteristics

Offset	- 0.4 to 0.0 mV/V (Other nominal values available on request)
Total error (Nonlinearity, hysteresis, nonrepeatability)	Pressure ranges: ≤ ± 0.4 % FS (terminal based)
Long term stability	≤ ± 0.3 % FS / year (at reference conditions)
TC Offset (TC0)	≤ ± 0.02 % FS/°C ⁴⁾
TC Span (TCS)	≤ - 0.013 % FS/°C ⁴⁾

Environmental Specification

Operating temperature range	- 40 to 135 °C
Storage temperature range	- 50 to 150 °C
Compensated temperature range	0 to 85 °C

- ¹⁾ PSI values around rounded and for reference only
²⁾ only gauge available
³⁾ only sealed gauge available
⁴⁾ over compensated temperature range

CPM-502

Ceramic Pressure Sensor

Specifications

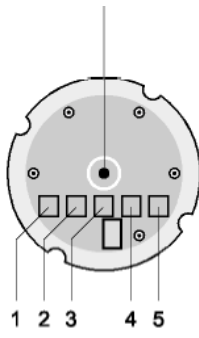
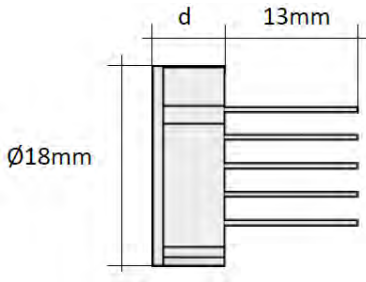
Electrical connections	
Standard	Pins, pitch 0.1 inch / 2.54mm
Miscellaneous	
Media wetted parts	Ceramic Al ₂ O ₃ 96 %
Weight	approx. 7 g
Dimension	Ø = 18 ± 0.1 mm d = 6.15 to 7.55 ± 0.1 mm
Mechanical	
Venting hole: - open for gauge version - closed for absolute and sealed gauge version	
	
	

Ordering code																																																																											
CPM502		-																																																																									
<table border="1"> <tr> <td>Type of pressure</td> <td>absolute A</td> <td></td> <td></td> </tr> <tr> <td></td> <td>gauge G</td> <td></td> <td></td> </tr> <tr> <td></td> <td>sealed gauge S</td> <td></td> <td></td> </tr> <tr> <td>Pressure range</td> <td>7.5 psi / (only gauge) 0.5 bar</td> <td>L 7 5</td> <td></td> </tr> <tr> <td></td> <td>15 psi / 1 bar</td> <td>0 1 5</td> <td></td> </tr> <tr> <td></td> <td>30 psi / 2 bar</td> <td>0 3 0</td> <td></td> </tr> <tr> <td></td> <td>75 psi / 5 bar</td> <td>0 7 5</td> <td></td> </tr> <tr> <td></td> <td>150 psi / 10 bar</td> <td>1 5 0</td> <td></td> </tr> <tr> <td></td> <td>300 psi / 20 bar</td> <td>3 0 0</td> <td></td> </tr> <tr> <td></td> <td>750 psi / 50 bar</td> <td>7 5 0</td> <td></td> </tr> <tr> <td></td> <td>1500 psi / (only sealed gauge) 100 bar</td> <td>1 K 5</td> <td></td> </tr> <tr> <td></td> <td>3000 psi / (only sealed gauge) 200 bar</td> <td>3 K 0</td> <td></td> </tr> <tr> <td></td> <td>6000 psi / (only sealed gauge) 400 bar</td> <td>6 K 0</td> <td></td> </tr> <tr> <td></td> <td>9000 psi / (only sealed gauge) 600 bar</td> <td>9 K 0</td> <td></td> </tr> <tr> <td>Electrical connection</td> <td>Solder pads tinned, pitch 0.1 inch / 2.54mm⁵⁾</td> <td>2 0 1</td> <td></td> </tr> <tr> <td></td> <td>Pins, pitch 0.1 inch / 2.54mm</td> <td>2 0 2</td> <td></td> </tr> <tr> <td></td> <td>Others – on request</td> <td>9 9 9</td> <td></td> </tr> <tr> <td>Options</td> <td>Standard</td> <td></td> <td>0 0 1</td> </tr> </table>				Type of pressure	absolute A				gauge G				sealed gauge S			Pressure range	7.5 psi / (only gauge) 0.5 bar	L 7 5			15 psi / 1 bar	0 1 5			30 psi / 2 bar	0 3 0			75 psi / 5 bar	0 7 5			150 psi / 10 bar	1 5 0			300 psi / 20 bar	3 0 0			750 psi / 50 bar	7 5 0			1500 psi / (only sealed gauge) 100 bar	1 K 5			3000 psi / (only sealed gauge) 200 bar	3 K 0			6000 psi / (only sealed gauge) 400 bar	6 K 0			9000 psi / (only sealed gauge) 600 bar	9 K 0		Electrical connection	Solder pads tinned, pitch 0.1 inch / 2.54mm ⁵⁾	2 0 1			Pins, pitch 0.1 inch / 2.54mm	2 0 2			Others – on request	9 9 9		Options	Standard		0 0 1
Type of pressure	absolute A																																																																										
	gauge G																																																																										
	sealed gauge S																																																																										
Pressure range	7.5 psi / (only gauge) 0.5 bar	L 7 5																																																																									
	15 psi / 1 bar	0 1 5																																																																									
	30 psi / 2 bar	0 3 0																																																																									
	75 psi / 5 bar	0 7 5																																																																									
	150 psi / 10 bar	1 5 0																																																																									
	300 psi / 20 bar	3 0 0																																																																									
	750 psi / 50 bar	7 5 0																																																																									
	1500 psi / (only sealed gauge) 100 bar	1 K 5																																																																									
	3000 psi / (only sealed gauge) 200 bar	3 K 0																																																																									
	6000 psi / (only sealed gauge) 400 bar	6 K 0																																																																									
	9000 psi / (only sealed gauge) 600 bar	9 K 0																																																																									
Electrical connection	Solder pads tinned, pitch 0.1 inch / 2.54mm ⁵⁾	2 0 1																																																																									
	Pins, pitch 0.1 inch / 2.54mm	2 0 2																																																																									
	Others – on request	9 9 9																																																																									
Options	Standard		0 0 1																																																																								

⁵⁾ minimum order quantity required

This data sheet contains product specification, properties are not guaranteed. Subject to be changed without notice.



CPM 602

Piezoresistive Monolithic Ceramic Pressure Sensor

- > Excellent chemical resistance
- > Easy mounting
- > Pressure ranges
30 to 6000 psi gauge



Standard Pressure Ranges

PSI ¹⁾	bar	Proof pressure		Admissible negative pressure [PSI ¹⁾ / bar]	Burst pressure		Output signal [mV/V]	
		[PSI ¹⁾ / bar]	[PSI ¹⁾ / bar]		[PSI ¹⁾ / bar]	[PSI ¹⁾ / bar]		
30	2	60	4	vacuum resistant	120	≥ 8	1.8 to 3.4	
75	5	150	10		300	≥ 20	2.0 to 3.5	
150	10	300	20		525	≥ 35	2.4 to 4.0	
300	20	600	40		900	≥ 60	2.8 to 4.2	
750	50	1500	100		2100	≥ 140	2.7 to 4.0	
1500 ³⁾	100	2250	150		4500	≥ 300	2.0 to 3.2	
3000 ³⁾	200	4500	300		6000	≥ 400	1.8 to 3.3	
6000 ³⁾	400	7500	500		9750	≥ 650	1.5 to 3.0	
other on request								

Reference Conditions

Supply voltage	2 to 30 V _{DC} stabilized (I _{max} = 4mA)
Bridge resistance	11 kΩ ± 30 %
Reference temperature	25 °C
Measuring supply voltage	10 V _{DC}

Performance Characteristics

Offset	- 0.4 to 0.0 mV/V (Other nominal values available on request)
Total error (non-linearity, hysteresis, non-repeatability)	Pressure ranges: ≤ 750 psi: ≤ ± 0.4 % FS (terminal based) Pressure ranges: > 750 psi: ≤ ± 0.8 % FS typ. (1.5 % FS max.) (terminal based)
Long term stability	≤ ± 0.3 % FS / year (at reference conditions)
TC Offset (TC0)	≤ ± 0.02 % FS / °C ²⁾
TC Span (TCS)	≤ - 0.012 % FS / °C ²⁾

Environmental Specification

Temperature range	- 40 to 135 °C
Storage temperature range	- 50 to 150 °C
Compensated temperature range	0 to 85 °C

- 1) PSI values around rounded and for reference only
- 2) Over compensated temperature range
- 3) Only sealed gauge available

CPM-602

Ceramic Pressure Sensor

Specifications

Electrical connection	
Standard	Pins, pitch 0.1 inch / 2.54mm
Miscellaneous	
Media wetted parts	Ceramic Al ₂ O ₃ 96 %
Weight	approx. 5 g
Dimension	Ø = 18 ± 0.1 mm d = 6.35 ± 0.1 mm
Mechanical	
<p>1 + IN 2 - OUT 3 GND 4 + OUT</p>	

Ordering code	
CPM602	-
Type of pressure	gauge G
Pressure ranges	
30 psi / 2 bar	0 3 0
75 psi / 5 bar	0 7 5
150 psi / 10 bar	1 5 0
300 psi / 20 bar	3 0 0
750 psi / 50 bar	7 5 0
1500 psi / 100 bar	1 K 5
3000 psi / 200 bar	3 K 0
6000 psi / 400 bar	6 K 0
Electrical connection	
Solder pads tinned, pitch 0.1 inch / 2.54mm ⁴⁾	2 0 1
Pins, pitch 0.1 inch / 2.54mm	2 0 2
Others – on request	9 9 9
Options	
Standard	0 0 1

4) minimum order quantity required

This data sheet contains product specifications, properties are not guaranteed. Subject to be change without notice.



SPM 401

Piezoresistive Silicon Pressure Sensor

- Calibrated and compensated
- With media separation
- Vacuum resistant
- O- ring mounting
- Pressure ranges: 1.5 to 100 psi

Applications

- Industrial
- Vacuum technology
- Pneumatic and hydraulic components (e.g. valves, pumps)
- Level measuring (e.g. environmental technology)

Specifications

All parameters are measured at supply current of 1 mA reference conditions unless otherwise specified

Standard Pressure Ranges													
PSI ¹⁾	bar	Output signal (Offset) [mV]			Output signal (Span) [mV]			Proof pressure [PSI ¹⁾ /bar]		Negative pressure [PSI ¹⁾ /bar]		Burst pressure [PSI ¹⁾ /bar]	
		min.	typ.	max.	min.	typ.	max.						
1.5	0.1	-2	0	2	14	33	60	15	1	-15	-1	22	≥ 1.5
3	0.2	-2	0	2	14	33	60	30	2	-15	-1	45	≥ 3
5	0.35	-2	0	2	50	75	100	30	2	-15	-1	45	≥ 3
15	1	-2	0	2	80	130	180	75	5	-15	-1	112	≥ 7.5
30	2	-2	0	2	80	130	180	150	10	-15	-1	225	≥ 15
50	3.5	-2	0	2	80	130	180	250	17.5	-15	-1	375	≥ 25
100	7	-2	0	2	80	130	180	500	35	-15	-1	750	≥ 50

Supply / Performance				
		min.	typ.	max.
Supply current	[mA]	-	1	3
Supply voltage	[V]	-	-	10
Linearity	[% FSO BFS]	- 0.25	± 0.1	0.25
Hysteresis	[%FSO]	- 0.05	± 0.02	0.05
Input impedance	[kΩ]	p _n ≤ 3 psi : 2.7 to 4.0		p _n > 3 psi: 4.0 to 6.0
Output impedance	[kΩ]	p _n ≤ 3 psi: 2.7 to 4.0		p _n > 3 psi: 4.0 to 6.0
Insulation resistance	[MΩ]	50 (between housing and sensor chip) @ 50 V _{DC}		
Rise time (10 to 90 %)	[ms]	≤ 0.1		

¹⁾ PSI values around rounded and for reference only

www.allensors.com Signed Original On File

www.allensors.com Signed Original On File

SPM-401

Piezoresistive silicon pressure sensor

Specifications

Thermal errors			
		$p_n \leq 5 \text{ psi}$	$p_n > 5 \text{ psi}$
Thermal error offset ²⁾	[% FSO]	$\leq \pm 1.0$	$\leq \pm 0.75$
Thermal error span ²⁾	[% FSO]	$\leq \pm 1.0$	$\leq \pm 0.75$
		0 to 70 °C (32 to 158 °F)	0 to 85 °C (32 to 185 °F)
Operating temperature ranges			
Medium	-40 to 125 °C	(-40 to 257 °F)	
Storage	-40 to 125 °C	(-40 to 257 °F)	

Mechanical stability	
Vibration	10 g RMS (20 to 2000 Hz)
Schock	100 g / 11 ms
Electrical connections	
Standard	4 Solder pads pitch 2.54

Materials / Filling fluids	
Housing	Stainless steel 316L (1.4404)
Diaphragm	Stainless steel 316L (1.4435)
Media wetted parts	Housing, diaphragm
Filling liquid	Silicone oil
Miscellaneous	
Installation position	any ³⁾
Protection class	IP 00
Weight	Standard: approx. . 10 g
Sealing	O-Ring 15,5 x 1,5 (material: FKM)

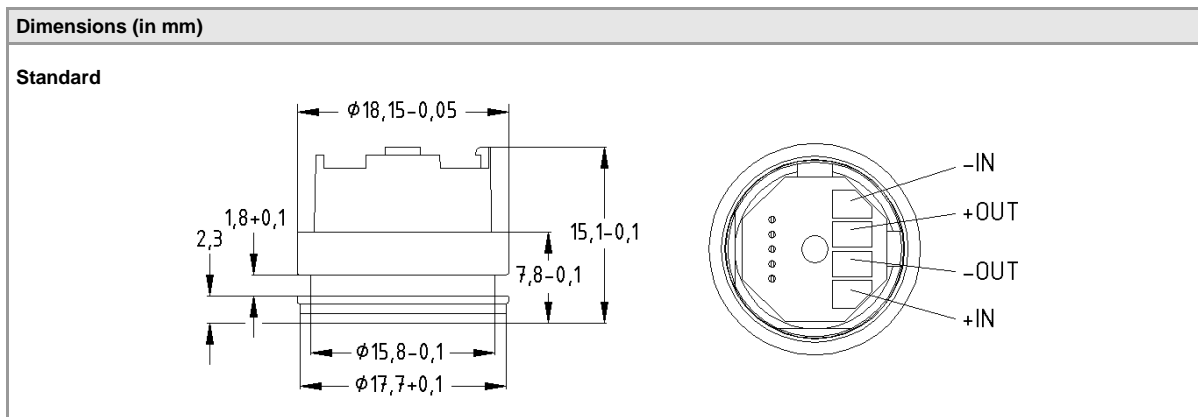
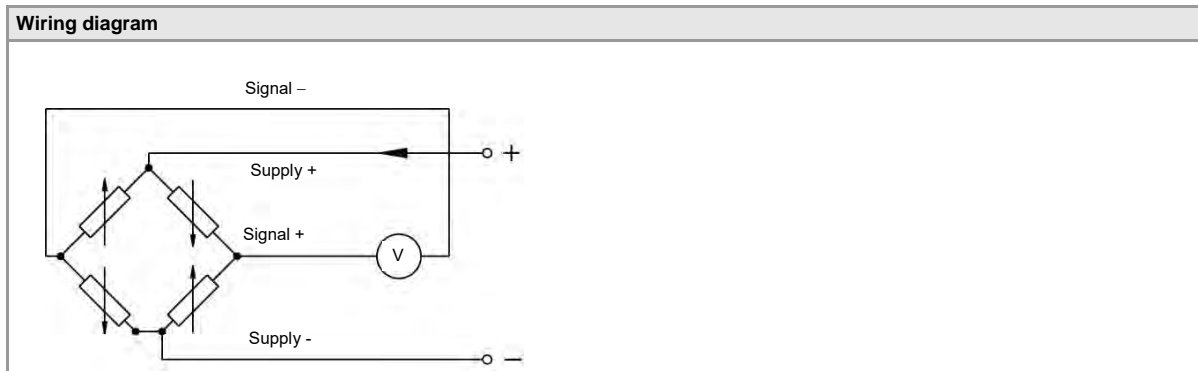

²⁾ error band within the compensated temperature range

³⁾ The sensors are calibrated with the face down diaphragm. By changing the mounting position the offset can shift a little for pressure ranges $p_n \leq 15 \text{ psi}$.

This data sheet contains product specification, properties are not guaranteed. Subject to be changed without notice.

SPM 402

Piezoresistive Silicon Pressure Sensor for medium pressure ranges

- Calibrated and compensated
- With media separation
- Excellent chemical resistance
- O- ring mounting
- Pressure ranges: 5 to 500 psi



Applications

- Industrial
- Pneumatic and hydraulic components (e.g. valves, pumps)
- Level measuring (e.g. environmental technology)
- Process industry

Specifications

All parameters are measured at supply current 1 mA at reference conditions unless otherwise specified.

Standard Pressure Ranges													
PSI ¹⁾	bar	Output signal (Offset) [mV]			Output signal (Span) [mV]			Proof pressure [PSI ¹⁾ /bar]		Negative pressure [PSI ¹⁾ /bar]		Burst pressure [PSI ¹⁾ /bar]	
		min.	typ.	max.	min.	typ.	max.						
5	0.35 ²⁾	-2	0	2	50	75	100	30	2	--	--	45	≥ 3
15	1				100	145	210	75	5	--	--	112	≥ 7.5
30	2				95	150	200	150	10	--	--	225	≥ 15
50	3.5				80	125	180	250	17.5	--	--	375	≥ 25
100	7				100	150	210	500	35	-15	-1	750	≥ 50
300	20				95	150	200	1200	80	-15	-1	1800	≥ 120
500	35				120	175	240	1500	105	-15	-1	3150	≥ 210
Supply / Performance													
		min.		typ.		max.							
Supply current	[mA]	-		1		3							
Supply voltage	[V]	-		-		10							
Linearity	[% FSO BFSL]	- 0.25		± 0.1		0.25							
Hysteresis	[%FSO]	- 0.05		± 0.03		0.05							
Input impedance	[kΩ]	4.0 to 6.0											
Output impedance	[kΩ]	4.0 to 6.0											
Insulation resistance	[MΩ]	50 (between housing and sensor chip) @ 50 V _{DC}											

¹⁾ PSI values around rounded and for reference only

²⁾ 5 psi / 350 mbar only gauge

SPM-402

Stainless steel pressure sensor

Specifications

Thermal errors				
		min.	typ.	max.
TC Offset	[% FS0/10K]	-0.7	-0.1	0.7
TC Span	[% FS0/10K]	-2.4	-1.9	-1.6
TC resistance	[%/10K]	2.4	2.75	3.3

All parameters are measured in the temperature range of 0 to 70 °C (32 to 158 °F)

Operating temperature ranges	
Media	-40 to 125 °C (-40 to 257 °F)
Storage	-40 to 125 °C (-40 to 257 °F)

Mechanical stability	
Vibration	10 g RMS (20 to 2000 Hz)
Schock	100 g / 11 ms

Electrical conditions	
Standard	4 solder pads pitch 2.54
Materials	
Housing	Stainless steel 316L (1.4404)
Diaphragm	Stainless steel 316L (1.4435)
Media wetted parts	Housing, diaphragm
Miscellaneous	
Installation position	any ³⁾
Protection class	IP 00
Weight	Standard: approx. 10 g
Sealing	O-Ring 15.5 x 1.5 (material: FKM)

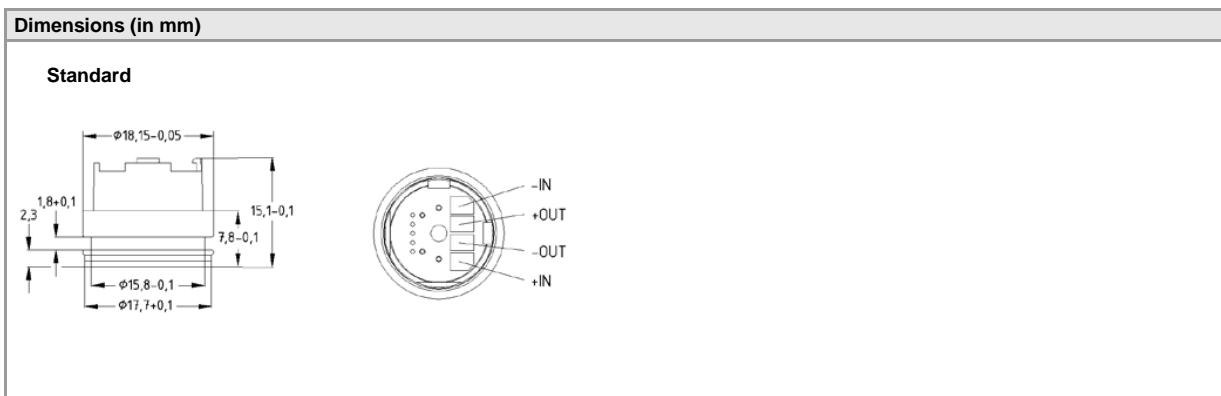
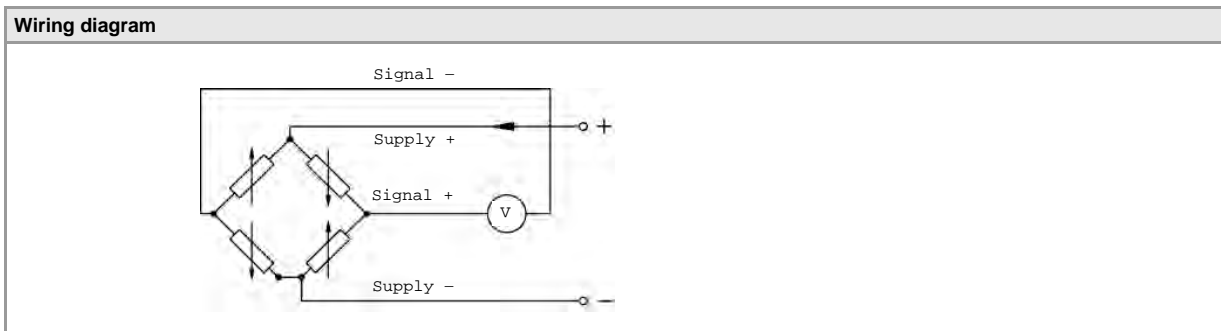

³⁾ The sensors are calibrated with the face down diaphragm. By changing the mounting position the offset can shift a little for pressure ranges $p_n \leq 15$ psi.

SPM-402

Stainless steel pressure sensor

Specifications

Ordering Codes

SPM402 -

Type of pressure																				
gauge	G																			
absolute	A																			
Pressure range																				
5 psi / 350 mbar	G	P	0	0	5															
15 psi / 1 bar		P	0	1	5															
30 psi / 2 bar		P	0	3	0															
50 psi / 3.5 bar		P	0	5	0															
100 psi / 7 bar		P	1	0	0															
300 psi / 20 bar		P	3	0	0															
500 psi / 35 bar		P	5	0	0															
Special pressure ranges			9	9	9	9														
Electrical connection																				
Solder pads						0	P	0												
others						9	9	9												
Housing material																				
Stainless steel 316L (1.4404)										8										
others										9										
Diaphragm material																				
Stainless steel 316L (1.4435)										1										
others										9										
Sealing																				
FKM										1										
others										9										
Transfer media																				
Silicone oil										1										
others										9										
Design																				
Standard										0	1									
venting tube										0	5									
others										9	9									
Special versions																				
Standard												0	0	0						
others												9	9	9						

Subject to change without advance notice

Media Isolated Sensors (Amplified)

CPA 502

Piezoresistive ceramic pressure sensor with flush membrane

- Digital calibrated
- Ratiometric output signal (0.5 to 4.5 V)
- Excellent chemical resistance
- Easy mounting
- Pressure ranges
7,5 to 750 psi gauge, absolute
1500 to 9000 psi sealed gauge

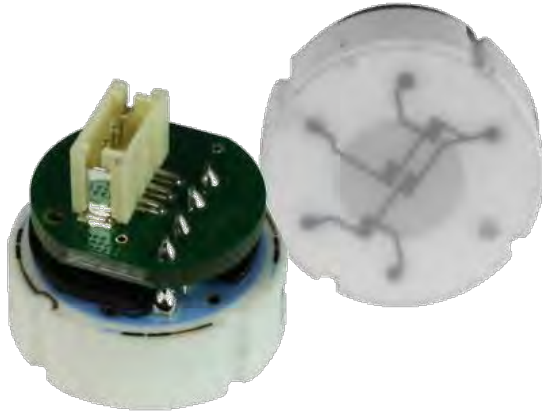

Standard Pressure Ranges

PSI ¹⁾	bar	Proof pressure		Admissible negative pressure		Burst pressure		Output signal (FSO) [V]	Sensor thickness [mm]
		[PSI ¹⁾ /bar]		[PSI ¹⁾ /bar]		[PSI ¹⁾ /bar]			
7.5 ²⁾	0.5 ²⁾	15	1	-2	-0.15	30	2	0.5 to 4.5 V (@ V _s = 5 V _{DC})	6.13
15	1	30	2	-3	-0.20	45	3		6.20
30	2	60	4	-6	-0.40	90	6		6.25
75	5	150	10	-11,5	-0.80	180	12		6.30
150	10	225	15	vacuum resistant		300	20		6.35
300	20	525	35			750	50		6.55
750	50	1500	100			1800	120		6.70
1500 ³⁾	100 ³⁾	2250	150			3000	200		6.70
3000 ³⁾	200 ³⁾	5250	350			7500	500		7.05
6000 ³⁾	400 ³⁾	7500	500			9750	650		7.35
9000 ³⁾	600 ³⁾	11250	750	14250	950	7.55			

Reference Conditions

Supply voltage	4.5 to 5.5 V
Output signal /Supply	3-wire ratiometric: 10 to 90% of V _s (V ₀ = 0.5 to 4.5 V _{DC} @ V _s = 5.0 V)
Reference temperature	25 °C
Measuring supply voltage	5 V _{DC}

Performance Characteristics

Supply current	≤ 2.5 mA
Offset	0.5 V @ V _s = 5 V
Span	4.0 V @ V _s = 5 V
Output load resistance	≥ 5 kΩ
Total error (Nonlinearity, hysteresis, nonrepeatability)	Pressure ranges: ≤ ± 0.4 % FS (terminal based)
Calibration error	≤ ± 0.3 %FS
Long term stability	≤ ± 0.3 % FS / year (at reference conditions)
TC Offset (TC0)	≤ ± 0.02 % FS/ °C ⁴⁾
TC Span (TCS)	≤ - 0.013 % FS/ °C ⁴⁾

¹⁾ PSI values around rounded and for reference only

²⁾ only gauge available

³⁾ only sealed gauge available

⁴⁾ over compensated temperature range



CPA 602

Piezoresistive Monolithic Ceramic Pressure Sensor

- Digital calibrated
- Ratiometric output signal (0.5 to 4.5 V)
- Excellent chemical resistance
- Easy mounting
- Pressure ranges 30 to 6000 psi gauge

Standard Pressure Ranges

PSI ¹⁾	bar	Proof pressure		Admissible negative pressure [PSI ¹⁾ /bar]	Burst pressure		Output signal (FSO) 0.5 to 4.5 V (@ V _s = 5V _{DC})	
		[PSI ¹⁾ /bar]			[PSI ¹⁾ /bar]			
30	2	60	4	vacuum resistant	120	≥ 8		
75	5	150	10		300	≥ 20		
150	10	300	20		525	≥ 35		
300	20	600	40		900	≥ 60		
750	50	1500	100		2100	≥ 140		
1500	100	2250	150		4500	≥ 300		
3000	200	4500	300		6000	≥ 400		
6000	400	7500	500		9750	≥ 650		
other on request								

Reference Conditions

Supply voltage	4.5 to 5.5 V _{DC}
Output signal / Supply	3-wire ratiometric: 10 to 90% of V _s (V ₀ = 0.5 to 4.5 V _{DC} @ V _s = 5.0 V)
Reference temperature	25 °C
Measuring supply voltage	5 V _{DC}

Performance Characteristics

Supply current	≤ 2.5 mA
Offset	0.5 V @ V _s = 5 V
Span	4.0 V @ V _s = 5 V
Output load resistance	≥ 5 kΩ
Total error (non-linearity, hysteresis, non-repeatability)	Pressure ranges: ≤ 750 psi: ≤ ± 0.4 % FS (terminal based) Pressure ranges: > 750 psi: ≤ ± 0.8 % FS typ. (1.5 % FS max.) (terminal based) (reduced error upon customer request)
Calibration error	≤ ± 0.3 % FS
Long term stability	≤ ± 0.3 % FS/year (at reference conditions)
TC Offset (TC0)	≤ ± 0.02 % FS / °C ²⁾
TC Span (TCS)	≤ - 0.012 % FS / °C ²⁾

¹⁾ PSI values around rounded and for reference only

²⁾ over compensated temperature range

www.allensors.com® Signed Original On File

www.allensors.com® Signed Original On File

CPA-602

Ceramic pressure sensor

Specifications

Environmental Specification																				
Operating temperature range	- 40 to 85 °C																			
Storage temperature range	- 40 to 100 °C																			
Compensated temperature range	0 to 85 °C																			
Electrical connection																				
on PCB of sensor	Mates with JST socket parts: B3B-ZR-SM4-TF																			
on connection wire	Connection housing: ZHR-3																			
	Connection pin:	Applicable wire																		
	Model No.	[mm ²]	AWG#	Insulation O.D.[mm]																
	SZH-002T-P0.5	0.08 ~ 0.13	28 ~ 26	0.8 ~ 1.1																
	SZH-003T-P0.5	0.032 ~ 0.08	32 ~ 28	0.5 ~ 0.9																
Miscellaneous																				
Media wetted parts	Ceramic Al ₂ O ₃ 96 %																			
Weight	approx. 7 g																			
Dimension	Ø = 18 ± 0.1 mm d = 6.35 ± 0.1 mm (excl. signal conditioning board)																			
Mechanical																				
Drawing		Pinout information																		
		<p>JST socket B3B-ZR-SM4-TF</p> <table border="1"> <tr> <td>3</td> <td>2</td> <td>1</td> <td>Pin Out</td> </tr> <tr> <td>○</td> <td>○</td> <td>○</td> <td>1: +5 V</td> </tr> <tr> <td></td> <td></td> <td></td> <td>2: GND</td> </tr> <tr> <td></td> <td></td> <td></td> <td>3: signal</td> </tr> </table>			3	2	1	Pin Out	○	○	○	1: +5 V				2: GND				3: signal
3	2	1	Pin Out																	
○	○	○	1: +5 V																	
			2: GND																	
			3: signal																	

Ordering code				
CPA602 <input type="checkbox"/> - <input type="checkbox"/> <input type="checkbox"/> <input type="checkbox"/> <input type="checkbox"/> <input type="checkbox"/> <input type="checkbox"/> <input type="checkbox"/> <input type="checkbox"/> <input type="checkbox"/> <input type="checkbox"/>				
Type of pressure				
gauge G				
Pressure ranges				
30 psi / 2 bar	0	3	0	
75 psi / 5 bar	0	7	5	
150 psi / 10 bar	1	5	0	
300 psi / 20 bar	3	0	0	
750 psi / 50 bar	7	5	0	
1500 psi / 100 bar	1	K	5	
3000 psi / 200 bar	3	K	0	
6000 psi / 400 bar	6	K	0	
Electrical connection				
JST socket	3	0	1	
Others – on request	9	9	9	
Options				
Standard				0 0 1

This data sheet contains product specification, properties are not guaranteed. Subject to be changed without notice.

www.allsensors.com Signed Original On File

www.allsensors.com Signed Original On File



SPA 401

Piezoresistive Silicon Pressure Sensor Module

- Calibrated and compensated
- With media separation
- Vacuum resistant
- O - ring mounting



Applications

- Industrial
- Vacuum technology
- Pneumatic and hydraulic components (e.g. valves, pumps)
- Level measuring (e.g. environmental technology)

Specifications

All parameters are measured at supply voltage 5V reference conditions unless otherwise specified

Standard Pressure Ranges											
PSI ¹⁾	bar	Output signal (Offset)		Output signal (FSO)		Proof pressure [PSI ¹⁾ /bar]		Negative pressure [PSI ¹⁾ /bar]		Burst pressure [PSI ¹⁾ /bar]	
			@ V _s = 5 V		@ V _s = 5 V						
1.5	0.1	10 % V _s	0.5 V	90% V _s	4.5 V	15	1	-15	-1	22	≥ 1.5
3	0.2					30	2	-15	-1	45	≥ 3
5	0.35					30	2	-15	-1	45	≥ 3
15	1					75	5	-15	-1	112	≥ 7.5
30	2					150	10	-15	-1	225	≥ 15
50	3.5					250	17.5	-15	-1	375	≥ 25
100	7					500	35	-15	-1	750	≥ 50
Supply / Performance											
		min.		typ.				max.			
Supply voltage V _s [V]		2.7		5.0				5.5			
Current consumption [mA]								2.5 max.			
Linearity [% FSO BFSL]		- 0.25		± 0.1						0.25	
Hysteresis [%FSO]		- 0.1		± 0.05						0.1	
Output load resistance [kΩ]		≥ 5									
Insulation resistance [MΩ]		50		(between housing and sensor chip)		@ 50 V _{DC}					

¹⁾ PSI values around rounded and for reference only

SPA-401

Piezoresistive silicon pressure sensor

Specifications

Thermal errors		
		$p_n \leq 5 \text{ psi}$
Thermal error offset ²⁾ [% FSO]		$\leq \pm 1.0$
Thermal error span ³⁾ [% FSO]		$\leq \pm 0.75$
		$0 \text{ to } 70 \text{ }^\circ\text{C} \text{ (32 to } 158 \text{ }^\circ\text{F)}$
		$0 \text{ to } 85 \text{ }^\circ\text{C} \text{ (32 to } 185 \text{ }^\circ\text{F)}$
Operating temperature ranges		
Media	-40 to 125 °C (-40 to 257 °F)	
Storage	-40 to 125 °C (-40 to 257 °F)	

Mechanical stability	
Vibration	10 g RMS (20 to 2000 Hz)
Schock	100 g / 11 ms
Electrical connections	
Standard	JST connector

Materials / Filling fluids	
Housing	Stainless steel 316L (1.4404)
Diaphragm	Stainless steel 316L (1.4435)
Media wetted parts	Housing, diaphragm
Filling liquid	Silicone oil
Miscellaneous	
Installation position	any ³⁾
Protection class	IP 00
Weight	Standard: approx. 10 g
Sealing	O-Ring 15.5 x 1.5 (material: FKM)

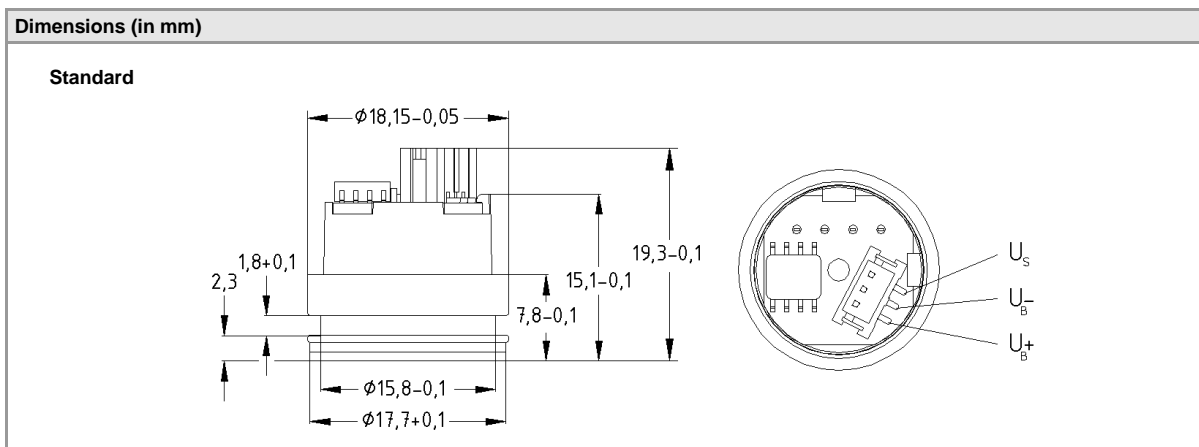
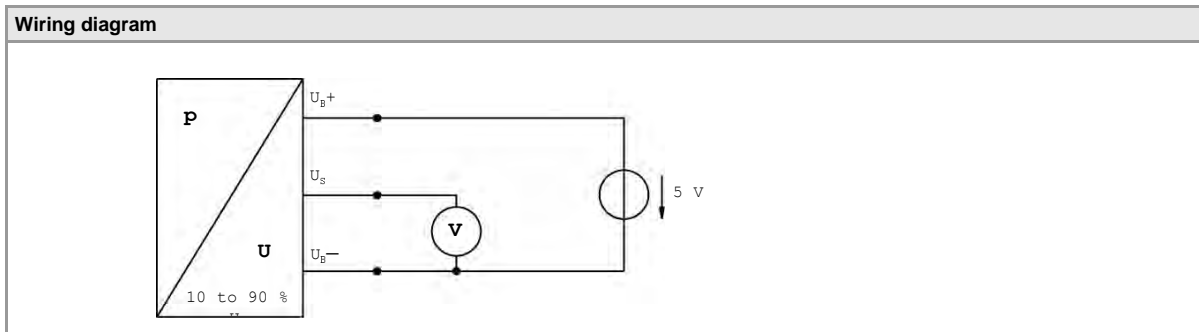

²⁾ error band within the compensated temperature range

³⁾ The sensors are calibrated with the face down diaphragm. By changing the mounting position the offset can shift a little for pressure ranges $p_n \leq 15 \text{ psi}$.

www.allsensors.com Signed Original On File

www.allsensors.com Signed Original On File

This data sheet contains product specification, properties are not guaranteed. Subject to be changed without notice.

SPA-401

Piezoresistive silicon pressure sensor

Specifications

Ordering Codes

SPA 401 -

Type of pressure												
gauge										G		
Pressure range												
1.5 psi / 100 mbar		P	L	1	5							
3 psi / 200 mbar		P	0	0	3							
5 psi / 350 mbar		P	0	0	5							
15 psi / 1 bar		P	0	1	5							
30 psi / 2 bar		P	0	3	0							
50 psi / 3.5 bar		P	0	5	0							
100 psi / 7 bar		P	1	0	0							
Special pressure ranges		9	9	9	9							
Electrical connection												
JST connector							Y	M	E			
others							9	9	9			
Housing material												
Stainless steel 1.4404										8		
others										9		
Diaphragm material												
Stainless steel 1.4435										1		
others										9		
Sealing												
FKM										1		
others										9		
Filling liquid												
Silicone oil										1		
others										9		
Design												
Standard										0	1	
others										9	9	
Special versions												
Standard										0	0	0
others										9	9	9

Subject to change without advance notice



www.allsensors.com Signed Original On File

www.allsensors.com Signed Original On File

SPA 402

Piezoresistive Silicon Pressure Sensor Module for medium pressure ranges

- Amplified
- Calibrated and compensated
- With media separation
- Excellent media resistance
- O- ring mounting
- Pressure ranges: 5 to 500 psi



Applications

- Industrial
- Pneumatic and hydraulic components (e.g. valves, pumps)
- Level measuring (e.g. environmental technology)
- Process industry

Specifications

All parameters are measured at supply voltage 5V at reference conditions unless otherwise specified

Standard Pressure Ranges / Output Signal ratiometric											
PSI ¹⁾	bar	Output signal (Offset)		Output signal (FSO)		Proof pressure [PSI ¹⁾ /bar]		Negative pressure [PSI ¹⁾ /bar]		Burst pressure [PSI ¹⁾ /bar]	
			@ V _s = 5V		@ V _s = 5V						
5 ²⁾	0,35 ²⁾	10 % V _s	0.5 V	90% V _s	4.5 V	30	2	--	--	45	≥ 3
15	1					75	5	--	--	112	≥ 7.5
30	2					150	10	--	--	225	≥ 15
50	3,5					250	17.5	--	--	375	≥ 25
100	7					500	35	-15	-1	750	≥ 50
300	20					1200	80	-15	-1	1800	≥ 120
500	35					1500	105	-15	-1	3150	≥ 210
Supply / Performance											
		min.		typ.		max.					
Supply voltage V _s	[V]	2.7		5.0		5.5					
Current consumption	[mA]	2.5 max.									
Linearity	[% FSO BFSL]	-0.25		± 0.1		0.25					
Hysteresis	[%FSO]	- 0.05		± 0.02		0.05					
Output load resistance	[kΩ]	≥ 5									
Insulation resistance		50 MΩ		(between housing and sensor chip)		@ 50 V _{DC}					







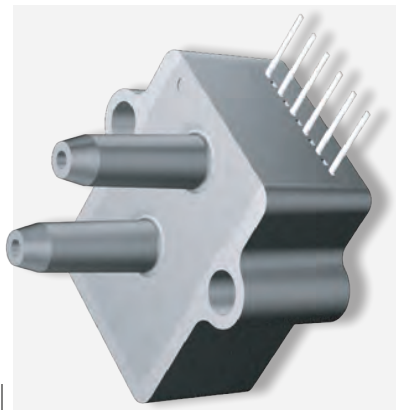







¹⁾ PSI values around rounded and for reference only

²⁾ 5 psi / 350 mbar only gauge

Packaging



A6 — A-Package
(millivolt, amplified, digital device)

Port Cut Options	Port Fitting Options	Lead Bend Options
 A — No Cut Port 'A' and 'B'	 A — No Fitting Port 'A' and 'B'	 F — Flat (Straight)
 B — Cut 0.085" Port 'A' and 'B'	 B — Barb Fitting Port 'A' Only	 J — Jogged Bend
 C — Cut 0.100" Port 'A' and 'B'	 C — Barb Fitting Port 'B' Only	 Q — Right Angle 0.075"
 D — Cut 0.150" Port 'A' and 'B'	 D — Barb Fitting Port 'A' and 'B'	 R — Right Angle 0.100"
 E — Cut 0.080" Port 'A' Only		
 D — Cut 0.370" Port 'A' Only		

Notes

- Standard : Local stock and delivery
- Semi Custom : Local stock and customization (additional charges apply)
- Custom : Overseas customization (longer lead times, additional charges and minimum lot size apply)
- Full Custom : Special tooling required (longer lead times, tooling charges and minimum lot size apply)

Semi-Custom Example—A6CBJ



A 6 C B J
 A-Package
 Six (6) leads
 Two (2) ports cut 0.100"
 Barb fitting, port 'A' only
 Jogged lead bend

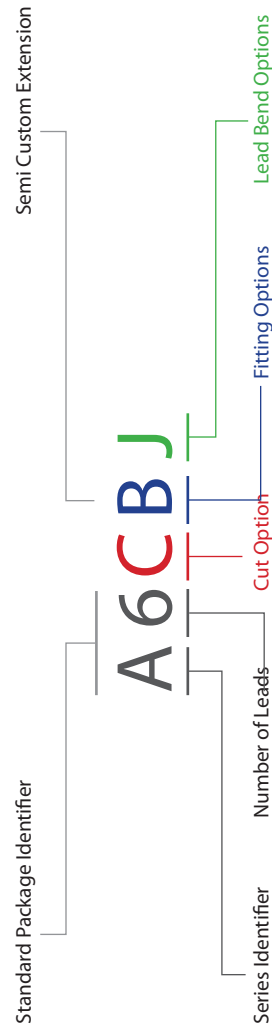

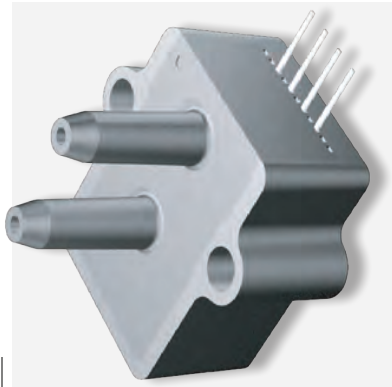

A4 — A-Package
(amplified output device)

Port Cut Options

A — No Cut Port 'A' and 'B'	
B — Cut 0.085" Port 'A' and 'B'	
C — Cut 0.100" Port 'A' and 'B'	
D — Cut 0.150" Port 'A' and 'B'	
E — Cut 0.080" Port 'A' Only	
D — Cut 0.370" Port 'A' Only	

Port Fitting Options

A — No Fitting Port 'A' and 'B'	
B — Barb Fitting Port 'A' Only	
C — Barb Fitting Port 'B' Only	
D — Barb Fitting Port 'A' and 'B'	

Lead Bend Options

F — Flat (Straight)	
J — Jogged Bend	
Q — Right Angle 0.075"	
R — Right Angle 0.100"	

Notes

- Standard : Local stock and delivery
- Semi Custom : Local stock and customization (additional charges apply)
- Custom : Overseas customization (longer lead times, additional charges and minimum lot size apply)
- Full Custom : Special tooling required (longer lead times, tooling charges and minimum lot size apply)

Semi-Custom Example—A4CBJ

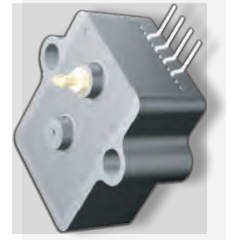

A 4 C B J
A-Package
Four (4) leads
Two (2) ports cut 0.100"
Barb fitting, port 'A' only
Jogged lead bend

Standard Package Identifier

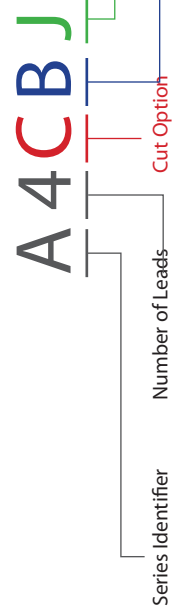

Semi Custom Extension



E-Package

(millivolt, digital output device)



EGNS

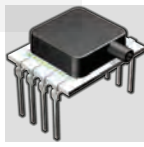

EGNL

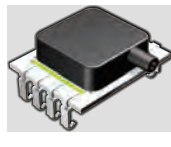

EGNJ

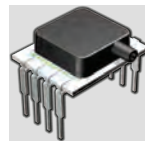

EGND



EGBS



EGBL



EGBJ

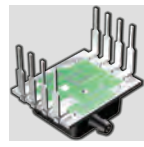

EGBD



E2NS

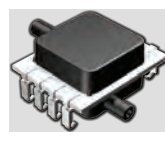

E2NJ

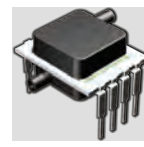

E2ND



E2BS



E2BD



E1NS



E1NJ

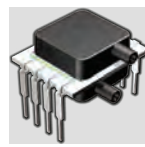

E1ND



E1BS

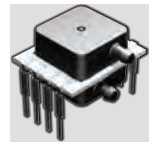

E1BD

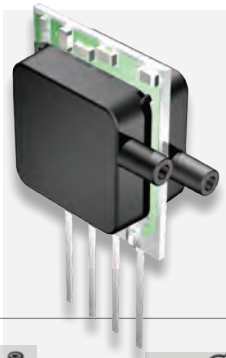

P-Package

(amplified output device)



PTNS

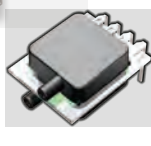

PTNR



PTNQ



PTBS



PTBR



P2NS

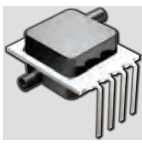

P2NR

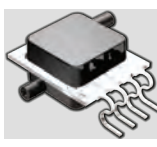

P2NQ



P2BS

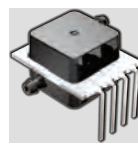

P2BR



P1NS

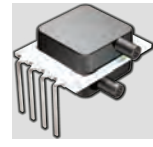

P1NR



P1NQ



P1BS



P1BR

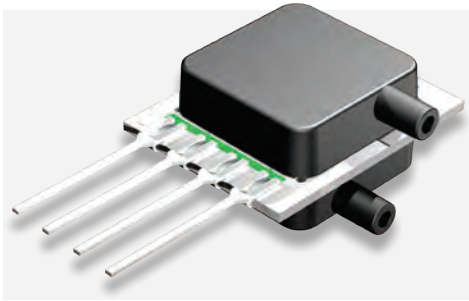

M-Package

(millivolt output device)

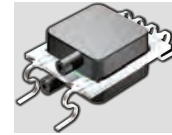

MTNT



MTNS



MTNR

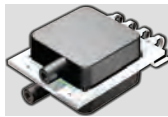

MTNQ

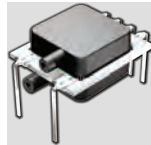

MTND



MTBS

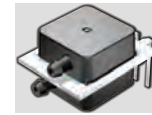

MTBR

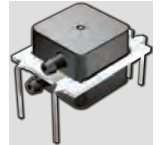

MTBD

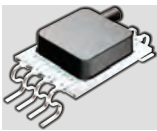

MLNT



MLNS

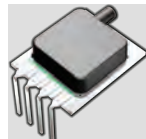

MLNR

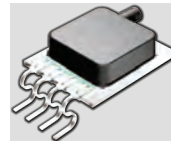

MLNQ

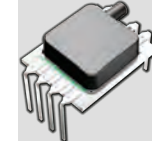

MLND

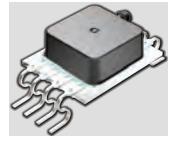

MLBT



MLBS

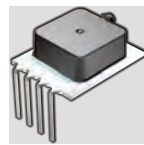

MLBR

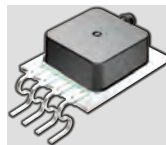

MLBQ

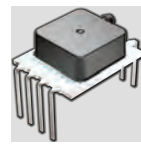

MLBD

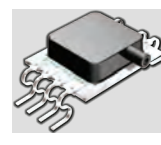

MGNT



MGNS

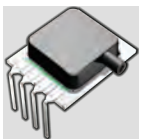

MGNR

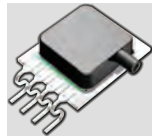

MGNQ

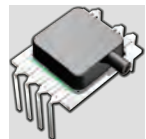

MGND

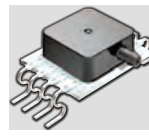

MGBT



MGBS

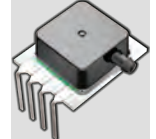

MGBR



MGBQ

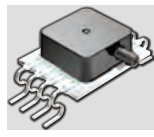

MGBT



M2NT



M2NS

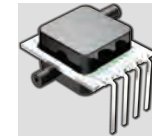

M2NR



M2NQ

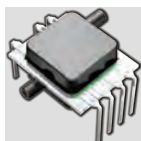

M2ND



M2BS

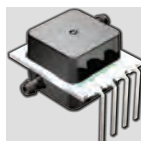

M2BR

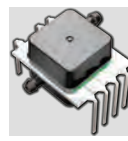

M2BD

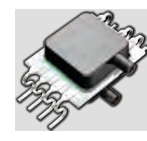

M1NT

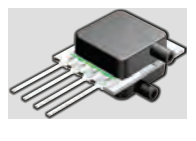

M1NS

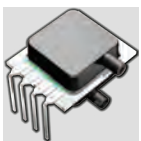

M1NR

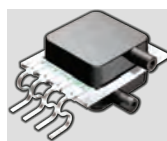

M1NQ

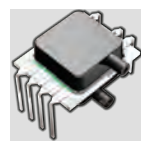

M1ND



M1BS

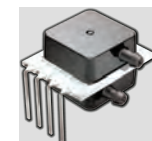

M1BR



M1BD



C-Package

(millivolt output device)



CPPT



CPPS

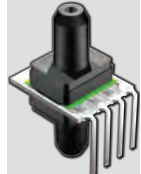

CPPR



CPPQ



CPPD

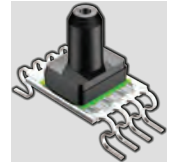

CPNT



CPNS



CPNR



CPNQ

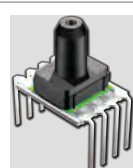

CPND



CPFT



CPFS



CPFR



CPFQ



CPFD

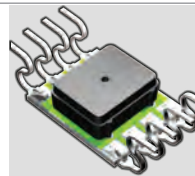

CFNW

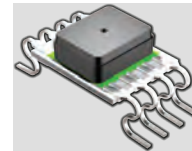

CFNT



CFNS

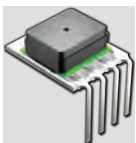

CFNR

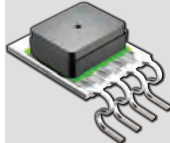

CFNQ

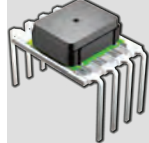

CFND

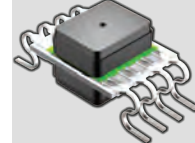

CFFT



CFFS

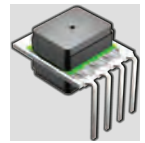

CFFR

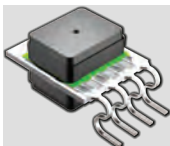

CFFQ

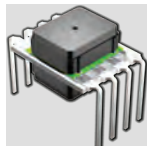

CFFD

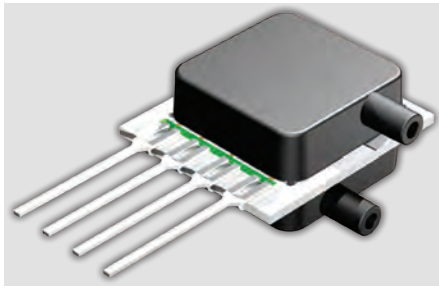

B-Package

(basic output device)

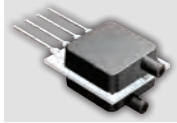

BTNS

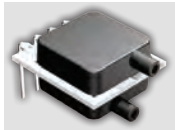

BTNR



BTNQ

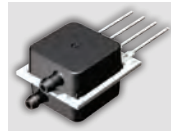

BTBS

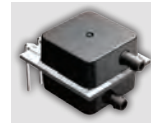

BTBR

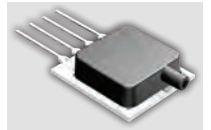

BLNS

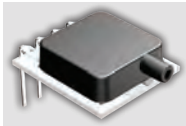

BLNR

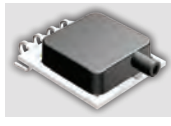

BLNQ



BLBS



BLBR



BLBQ

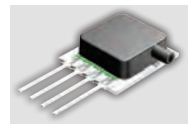

BGNS



BGNR



BGNQ



BGBS



BGBR



BGBQ



B2NS



B2NR



B2NQ

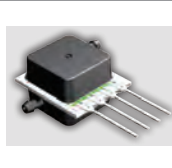

B2BS



B2BR



B1NS



B1NR



B1NQ



B1BR



B1BS



N-Package



N1BS

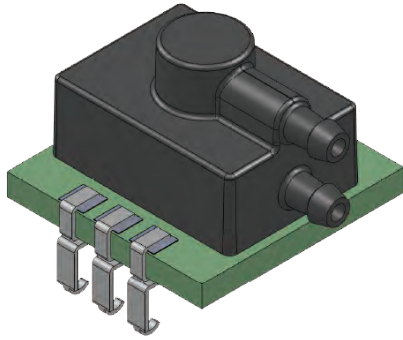

D-Package



D1



D3

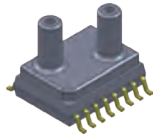

D4

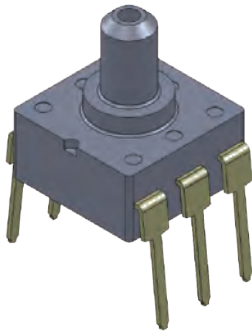

U-Package



U1



U2



U3



U4



U5



IC-Package

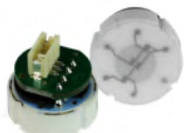

IC5A

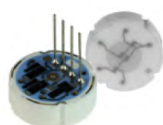

IC5M



IC6A



IC6M



IS-Package



IS41A



IS41M



IS42A



IS42M

White Papers

All Sensors **Pressure Points** are application tips to simplify designing with microelectromechanical (MEMS) pressure sensors and avoiding common pitfalls.

Pressure Point 1: MEMS Pressure Sensors - Pressure Measurement Types

Microelectromechanical system (MEMS) pressure sensors have changed the way that system designers and application engineers measure pressure. The simplicity of use, small size, low cost and ruggedness allow these sensors to address applications in automobiles and industrial process control as well as medical and handheld portable products. For example, a highly accurate altitude measurement in a handheld navigation device such as a smartphone that has three-axis accelerometers, gyroscope and magnetometers adds a tenth degree of freedom. Pressure sensing allows the navigation device to locate the exact floor of a destination.

MEMS pressure sensors typically measure the pressure difference across a silicon diaphragm. As shown in Figure 1, there are three types of measurements:

- Gauge or gage (a) , where the pressure is referenced to the atmosphere
- Absolute (b) where the pressure is measured against a reference vacuum sealed inside the chip assembly
- Differential (c), where the pressure is measured as the difference between two pressures (delta P or ΔP)

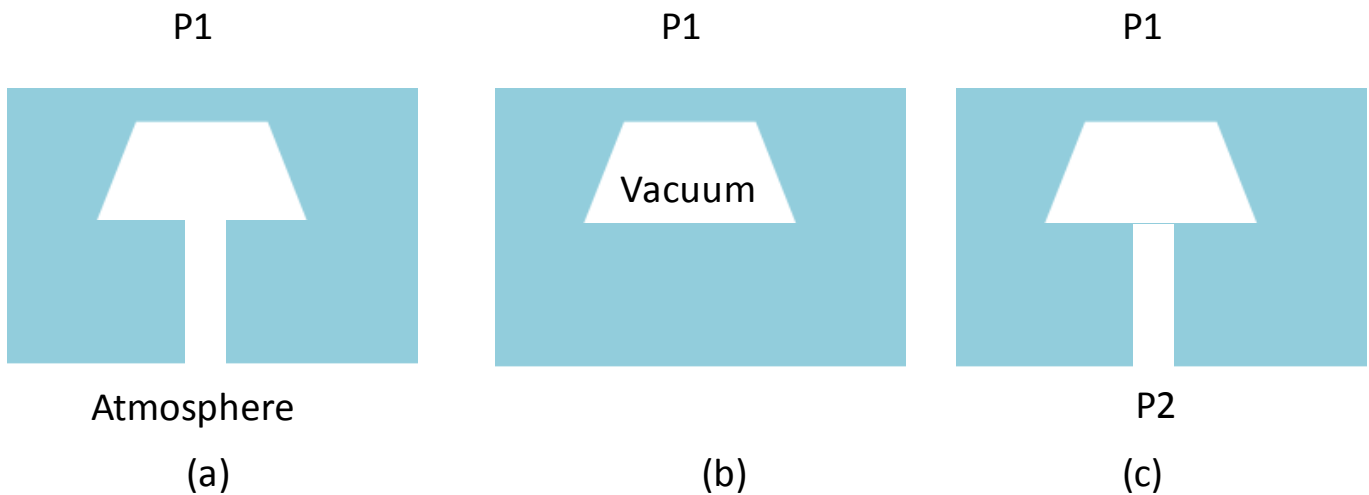

Figure 1. Gage, absolute and differential pressure measurements have different types of pressure on each side of the diaphragm.

In these designs, the diaphragm is etched from silicon using micromachining, a chemical etching process. The measurement technique can involve capacitive or resistive (piezoresistive or pressure sensitive resistors). Piezoresistive designs are shown in Figure 1. Vacuum is a negative gauge pressure or a value below atmospheric pressure. When specifying or discussing the type of pressure measurement, it is essential to identify the type of measurement to convey an accurate description of the measurement technique. Table 1 shows the sensor requirements for several common measurements.

Application requirements for absolute, gauge and differential pressure sensing

Measurement	Type	Value (nominal)
Atmospheric pressure	absolute	760 Torr (101.3 kPa)
Altitude	absolute	Look up table/calculate
Manifold pressure (vehicle)	absolute	100 kPa
Depth in water	absolute	Calculate
In vivo blood Pressure	absolute	80/120-mm (300 mm Hg, max)
Ex vivo blood pressure	gauge	80/120-mm (300 mm Hg, max)
Height of liquid column	gauge	Calculate
Intraocular pressure	gauge	15 mm Hg
Tire pressure	gauge	30 psi
Vacuum cleaner	gauge	760 to 25 Torr (100 to 3 kPa)
Liquid or gas flow	differential	Application dependent
Respirator	differential	4 kPa
Ventilator	differential	25 cm H ₂ O
Spirometer	differential	4 kPa

Table 1. Common pressure measurement versus type of measurement.

Atmospheric Pressure and Altitude

Perhaps the most fundamental pressure measurement is atmospheric pressure. Standard atmospheric pressure at sea level is 29.92 inches of mercury (Hg) (760 mm Hg (Torr) or 14.696 psi). The atmospheric pressure decreases with increasing altitude and increases at altitudes below sea level. Weather patterns with low and high fronts decrease or increase atmospheric pressure. An aneroid barometer provides an absolute pressure measurement.

An altimeter is an absolute pressure gauge (measurement) that shows height above sea level. The air pressure to height above sea level conversion is frequently performed using a [look up table](#). For example, 10,000 feet above sea level is 10.1 psia (69.7 kPa). Pressure altitude (h_{alt}) can be calculated using the [equation](#):

$$h_{alt} = (1 - (p_{sta}/1013.25)^{0.190284}) \times 145366.45 \quad \text{Eq. 1}$$

Where:

h_{alt} is the height in feet

and p_{sta} is the pressure in millibars (mb) or hectopascals (hPa)

Height of a Liquid Column

For a standing liquid, the absolute pressure at a depth H in a liquid is defined as:

$$P_{abs} = P + (\rho \times g \times H) \quad \text{Eq. 2}$$

Where:

P_{abs} is the absolute pressure at depth H in kg/m-s² (or Pa)

P is the external pressure at the top of the liquid, typically atmospheric pressure for open systems

ρ is the density of the fluid (for example, pure water is 1 g/cm³ at 4°C and salt water is 1.025 g/cm³)

g is the acceleration due to gravity (g = 9.81 m/s²) (32.174 ft/s²)

and H is the depth in meters or feet

Depth in Water

The [pressure on submerged bodies](#) increases based on the density of the liquid and depth in the liquid according to Eq. 2. Common measurements include depth in fresh or salt water. For fresh water, pressure increases 0.43 psi per foot and in salt water it is 0.44 psi per foot. A scuba diver's submersible pressure gauge (SPG) or depth gauge makes an absolute pressure reading. A dive computer provides the time required for a safe ascent, since even a depth of 100 feet can produce a pressure of 400 kPa (3.951 atmospheres, or 58.1 psi).

Flow in a Pipe/Tube

Several factors determine the pressure drop that occurs in fluid flow applications including laminar versus turbulent flow, the flow velocity, kinematic viscosity and Reynolds number of the fluid, internal roughness of the inside of the pipe as well as its diameter, length and form factor. [Orifice plates, venturi tubes and nozzles](#) simplify the situation. In these cases (refer to Figure 2), the flow is related to ΔP ($P_1 - P_2$) by the equation:

$$q = c_d \pi/4 D_2^2 [2(P_1 - P_2) / \rho(1 - d^4)]^{1/2}$$

Where:

q is the flow in m^3/s

c_d is the discharge coefficient, the area ratio = A_2 / A_1

P_1 and P_2 are in N/m^2

ρ is the fluid density in kg/m^3

D_2 is the orifice, venturi or nozzle inside diameter (in m)

D_1 is the upstream and downstream pipe diameter (in m)

and $d = D_2 / D_1$ diameter ratio

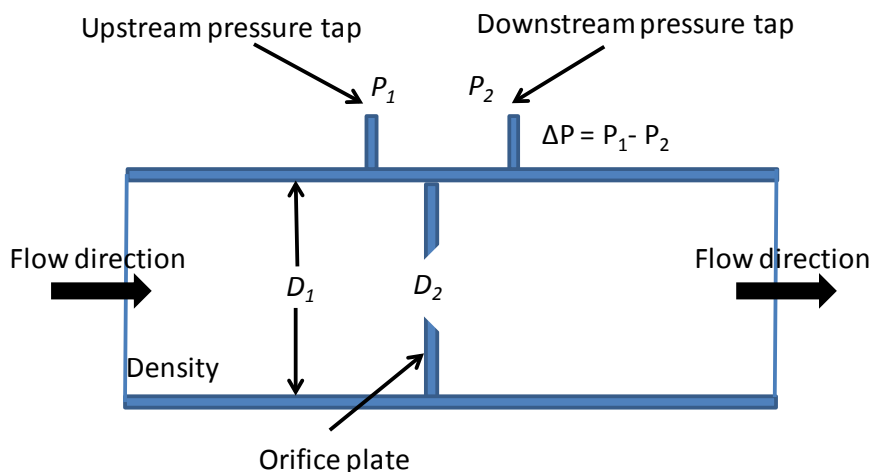

Figure 2. Elements of a ΔP flow measurement.

Pressure Parameters

As the examples demonstrate, pressure measurements use a variety of pressure standards to express the reading depending on the application. To convert between different pressure standards:

<http://www.wrh.noaa.gov/slc/projects/wxcalc/formulas/pressureConversion.pdf>

All Sensors **Pressure Points** are application tips to simplify designing with microelectromechanical (MEMS) pressure sensors and avoiding common pitfalls.

Pressure Point 2: Understanding Accuracy and Precision for MEMS Pressure Sensors

In most applications, accuracy is one of the more critical specifications that a product needs to meet. However, accuracy is also one of the more, if not the most, confusing parameter for any product including MEMS pressure sensors. This application tip provides system designers with insight to deal with the numerous sources of confusion.

Accuracy versus Precision

Accuracy and precision are frequently used interchangeably, especially in promotional literature for sensor products. Two figures identify the obvious differences between the two specifications. Figure 1 shows the statistical distribution for precision versus the proximity to an actual, target or reference value for accuracy. A more precise sensor has a narrower distribution and a more accurate sensor is closer to the actual value. Alternatively, Figure 2 shows how precision and accuracy can increase or decrease independently.

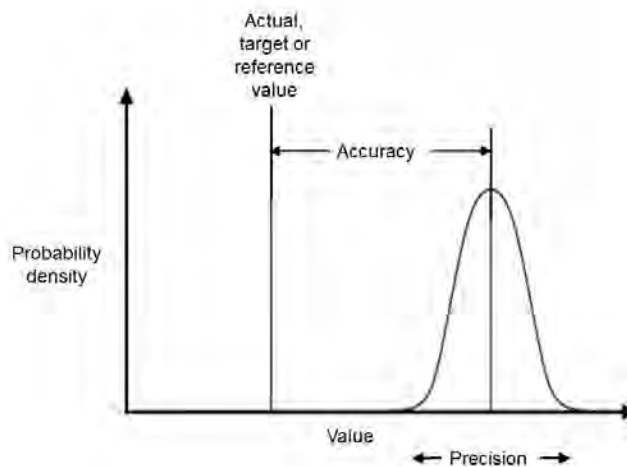

Figure 1. The relationship between accuracy and precision.

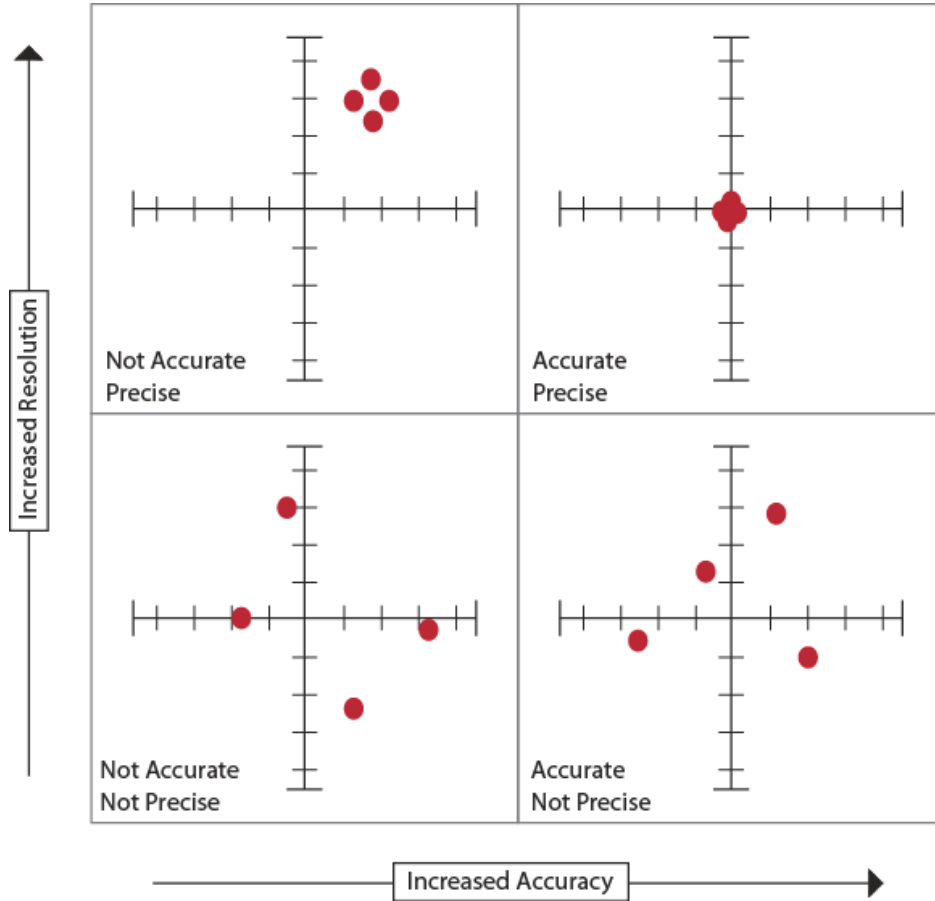

Figure 2. A target provides an informative image of the difference between accuracy and precision.

Precision and resolution are also frequently abused parameters. Unlike precision, resolution is the smallest measurement a sensor can reliably indicate, which is typically important in identifying input changes at low signal levels from noise in the application. An analog to digital converter (ADC) that quantizes the smooth output of an analog sensor for use in a digital control application has increased resolution as the number of bits increases. Figure 3 shows the difference between resolution and accuracy when the sensor's output is quantized.

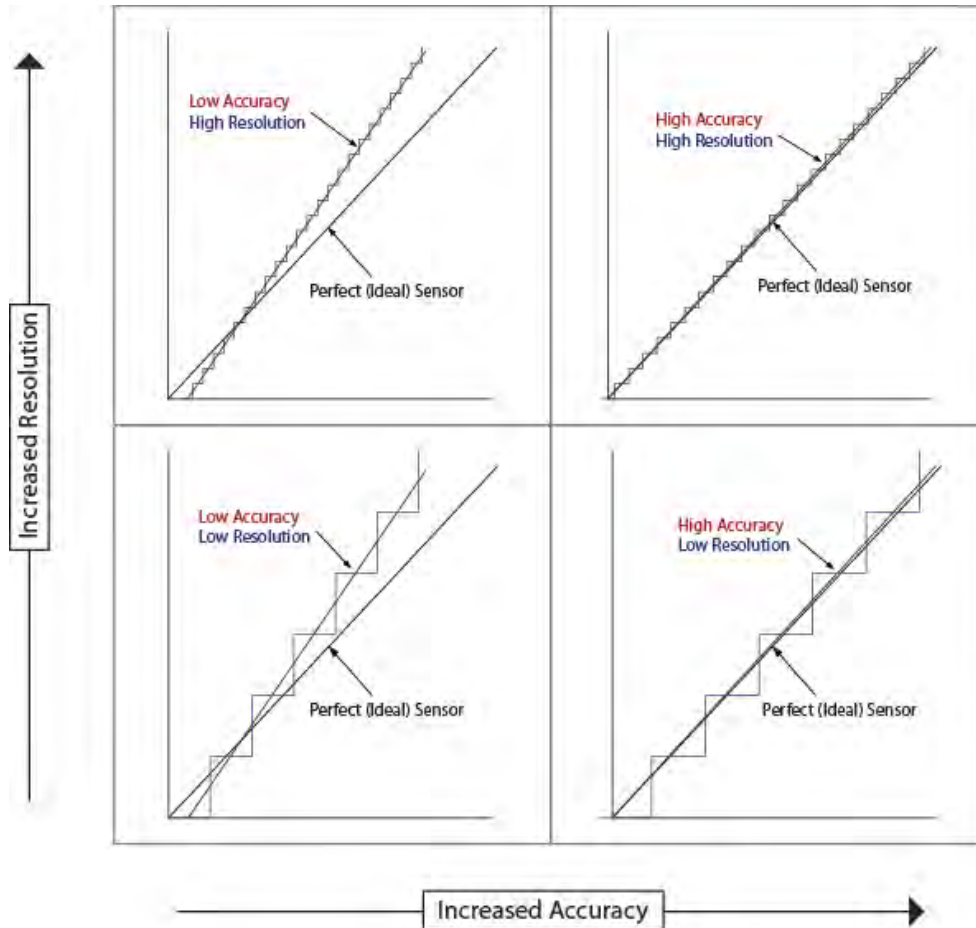

Figure 3. The visual difference between accuracy and resolution and an ideal sensor. High resolution and high accuracy occur in the upper right hand corner.

Specifying Accuracy

When a company compares its own products with claims of twice the accuracy for one model or family over another, the comparison should be accurate. However, there are many accepted formats for measuring and specifying accuracy, so comparing the accuracy of one company’s product verses another company’s product is much more difficult. Some industries, such as automotive or aerospace specify how accuracy should be measured to simplify this process.

Accuracy is usually specified in terms of inaccuracy or error. In general, sources of error include: zero error, span error, pressure-non-linearity, thermal effect on zero, thermal effect on span, thermal hysteresis, pressure hysteresis, and non-repeatability. Other system considerations that can affect accuracy include response time, ratiometricity, long term stability or stability over life, and more.

The first step toward comparing any pressure sensor data is using the same output specification of mm of mercury (Hg), kilopascals (kPA), bar, inches of water, etc. Typically, most MEMS pressure sensor measurements are made at a fixed voltage and room temperature. The two primary approaches for specifying accuracy are total error band and error budget.

Total Error Band (TEB) accuracy specifies the maximum deviation of the output values within limits defined by the sensor’s underlying technology. In some instances, an error band multiplier increases the allowed inaccuracy at

extremes such as increasing the temperature error at low and high temperatures as shown in Figure 4. The error band may also increase at pressure or other upper or lower limits.

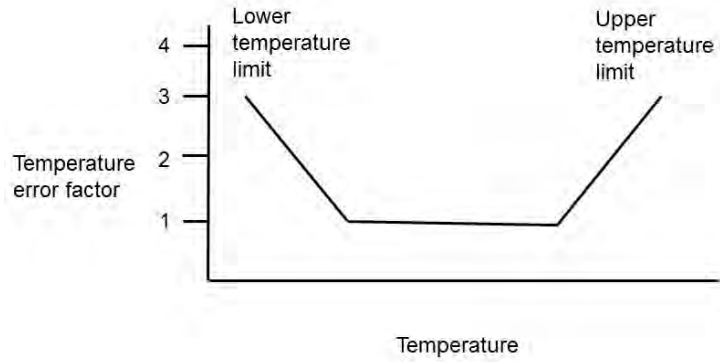

Figure 4. The temperature error factor can increase the allowed sensor error by a value such as ± 3 times at the temperature limits.

Error Budget accuracy can consist of linearity, temperature and pressure hysteresis, the temperature coefficient of span, and the temperature coefficient of offset. Figure 5 shows a typical error budget plot. The transfer function can be provided with \pm error values, and the limits may have a curved shape at upper or lower limits as well.

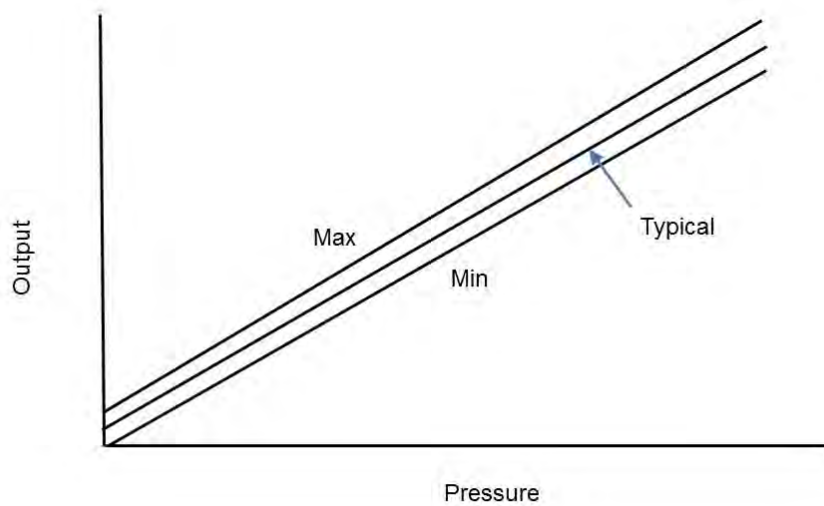

Figure 5. The error budget provides max and min tolerances around a typical level.

Other factors that influence accuracy are the characteristics shape of the curve of the sensing technology and operating point of the application. For example, an endpoint specification may not be appropriate for an application that normally operates in the mid-range of full scale.

Obtaining the Required Accuracy

There several different approaches to specify sensor accuracy. Two common techniques have been discussed. The supplier's choice of an accuracy specification usually involves the technology used for the sensor, choice of test equipment, ease of testing (frequently to address cost objectives) and/or a targeted volume market segment such as industrial, automotive, medical, consumer, etc. The challenge for the user when comparing products from different suppliers is to fully research each supplier's methodology for specifying accuracy and then choose the approach and sensor that best meets the application requirements.



All Sensors **Pressure Points** are application tips to simplify designing with microelectromechanical (MEMS) pressure sensors and avoiding common pitfalls.

Pressure Point 3: Linearity Measurements for MEMS Pressure Sensors

Pressure non-linearity is one of the parameters that impacts sensor accuracy. (For other factors, refer to All Sensors Pressure Point 2: Understanding Accuracy and Precision for MEMS Pressure Sensors.) As such, users need to understand some of the nuances involved with measuring and specifying linearity.

Design Impact for MEMS Pressure Sensors

Factors that impact piezoresistive pressure sensor linearity are the topology and placement of the piezoresistive elements, diaphragm thickness, and construction elements. Generally, temperature has little effect on linearity except in highly sensitive applications. As a result, sensor manufacturers only test for linearity at ambient temperature.

The main linearity issue is how the results are computed and reported. The following identifies common test methods and specification techniques for determining the linearity of MEMS pressure sensors and other sensors, as well as a lesser known linearity situation that specifically impacts MEMS pressure sensors.

End-Point Method

The most straightforward nonlinearity specification is the end-point method. As shown in Figure 1, it starts with the line from the output at zero pressure and extends to the output at rated pressure. The nonlinearity is the maximum deviation from the end-point straight line (Equation1). Typically, this value is expressed in percent of full scale span (%FSS).

Note: at the rated pressure, a particular sensor's output can be above or below the nominal output.

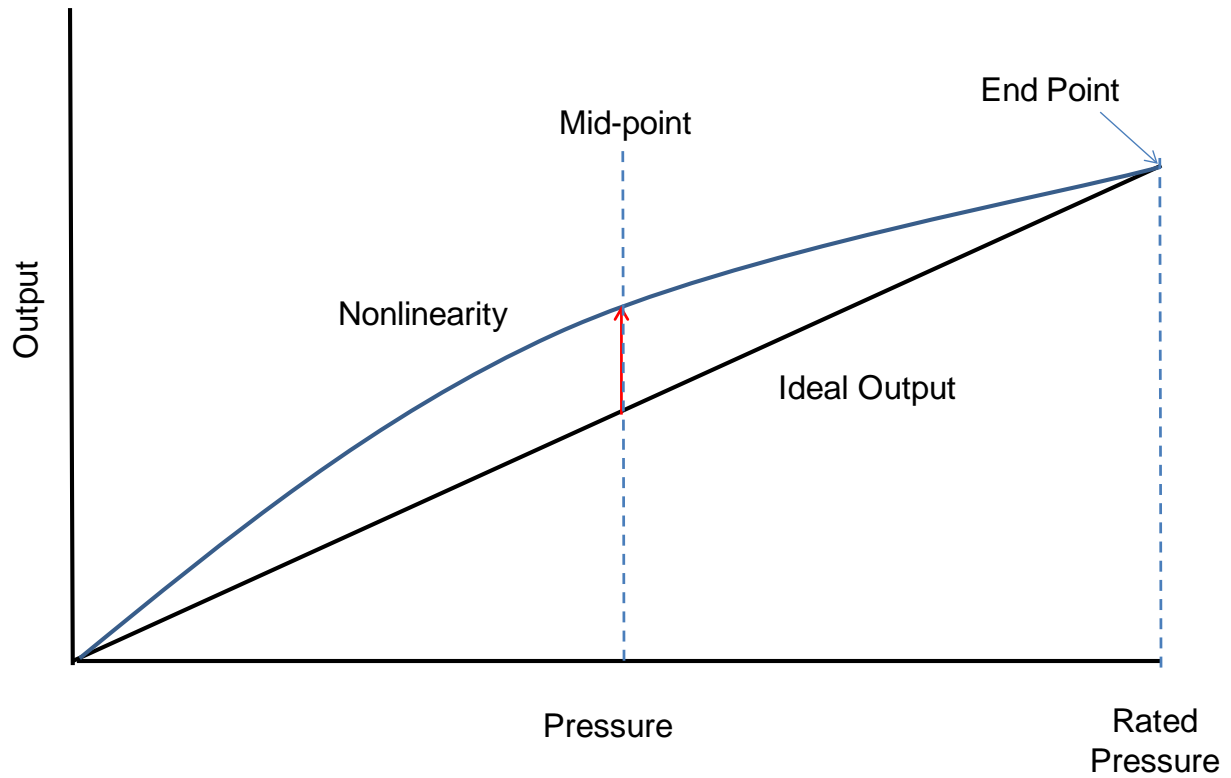

Figure 1. End-point nonlinearity is easy to observe in a sensor with a simple output curve.

$$V_o = Mx + b$$

...Equation 1

Where:

V_o = sensor output

M = the slope of the endpoint line

x = the value of the measurand at a given point

b = the zero offset

Best-Fit Straight Line Method

The best-fit straight line (BSFL) method of linearity minimizes the deviation from output curve. As shown in Figure 2, BSFL linearity can be as much as half of the endpoint method. (A=B.)

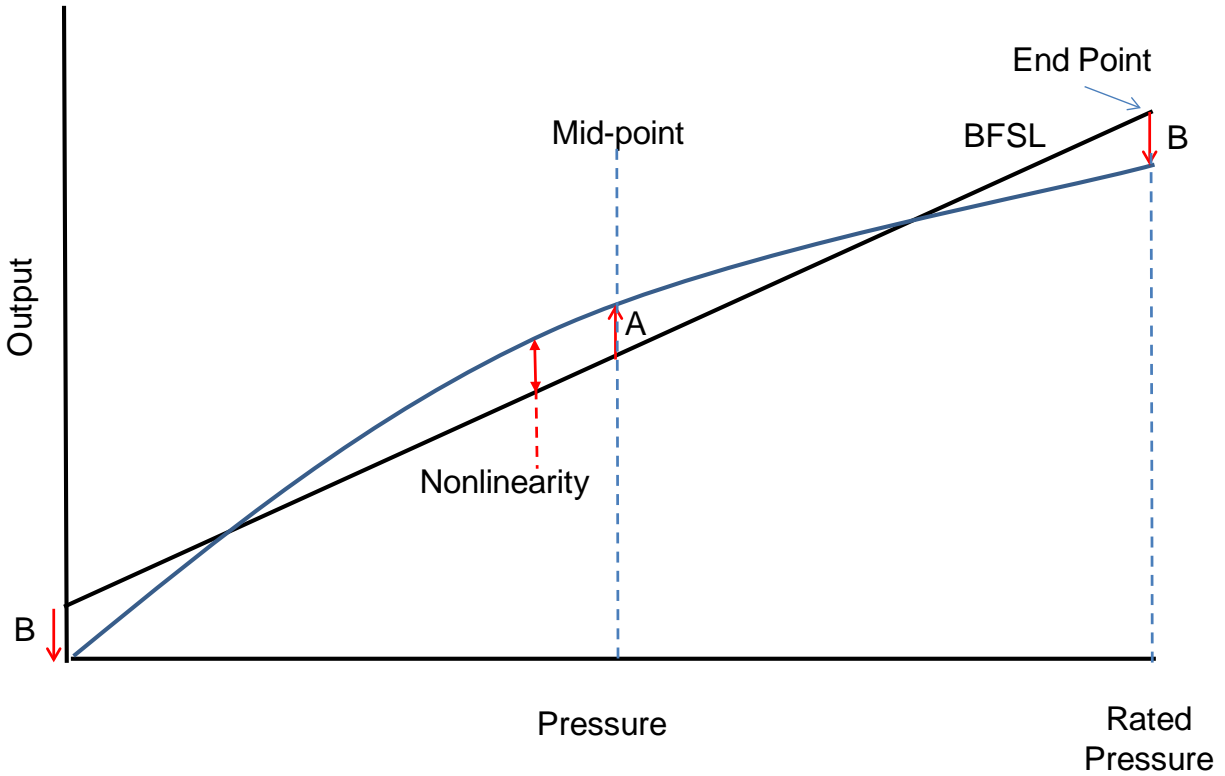

Figure 2. The best-fit straight line minimizes the variation for the actual output.

The Least Squares Fit Method

The least squares BSFL (or simply least squares) method (Equation 2) is a statistical means of determining the BSFL that can be implemented in production test equipment. The least squares fit method allows the use of a different number of points. As Figure 3 shows, the linearity error at the mid-point will generally not be the same as the linearity error at the end points. (A ≠ B.)

$$\text{Slope} = \frac{\sum_{d=1}^n X_d Y_d}{\sum_{d=1}^n X_d^2}$$

...Equation 2

Where:

X_d = known input data points

Y_d = actual sensor output at each X_d data point

N = number of data points

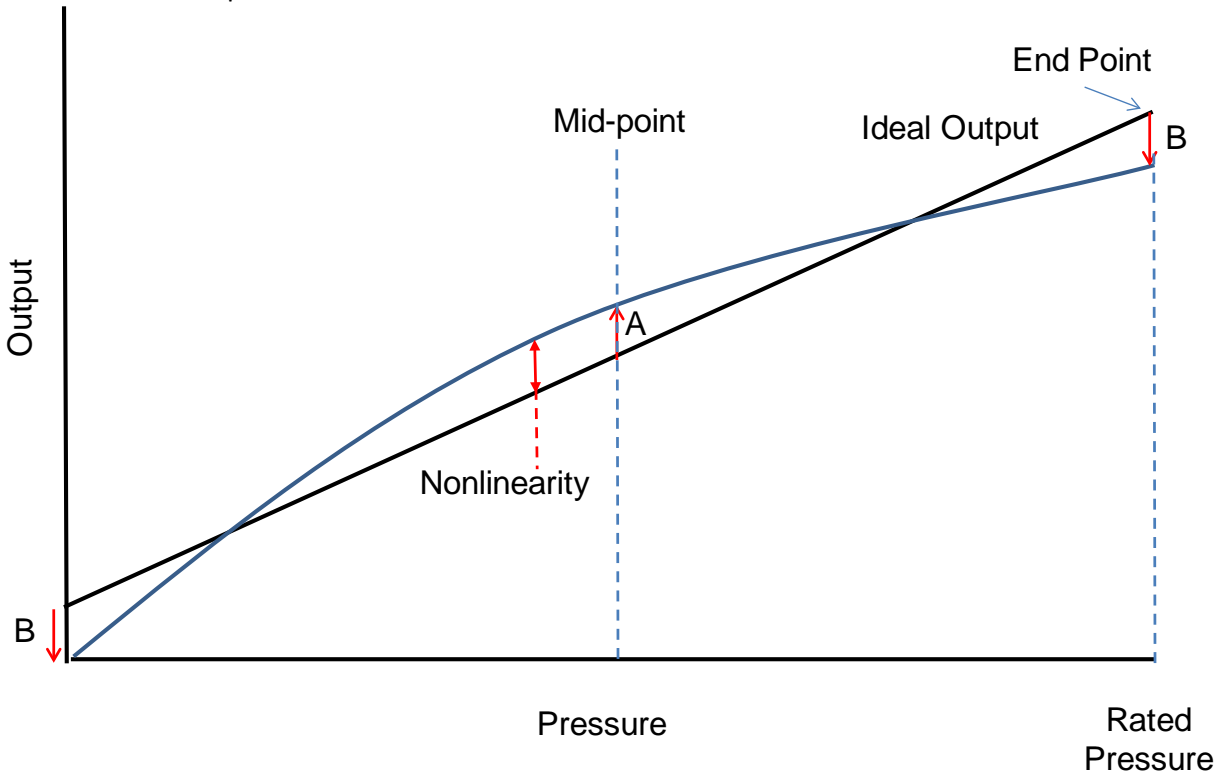

Figure 3. The least squares fit method is the method of determining the sum of the least squares.

Difference Between Front-Side And Back-Side Pressure

Suppliers typically only test for linearity on the top or front side of the sensor. However, in some cases, both front and back side pressure are specified. Users need to be aware of the difference between the readings. If the supplier tests one side and the customer uses the opposite side, the performance can be quite different. In addition to sensitivity, the linearity can be directly impacted as well.

Backside Linearity

In a harsh environment, applying pressure to the backside of the sensor is a common solution for improved media compatibility. As long as the fluid or media is compatible with materials on the backside of the sensor, a more rugged application results. As noted previously, users need to be aware of the performance impact of applying pressure to the backside.

Front-to-Back Linearity



Front-to-back linearity (Lin_{FB}) compares the gain (expressed as span) on the front side to the gain on the backside of a pressure sensor. Equation 3 shows the calculation for Lin_{FB} .

$$Lin_{FB} = \{ |Span_{Front} / Span_{Back} | - 1 \} \cdot 100\% \quad \dots \text{Equation 3}$$

Where:

$Span_{Front}$ = the full scale span with pressure applied on the front side of the pressure sensor

$Span_{Back}$ = the full scale span with pressure applied to the back of the pressure sensor

For differential applications that need both positive and negative pressure applied to the sensor, Lin_{FB} can be an important performance factor. If the front-to-back linearity is acceptable, users do not need to perform a separate calibration for positive and negative pressures. This can cut test time dramatically.

The Value of Front-to-Back Linearity

Front-to-back linearity can have as much as a 7 to 8% difference if the sensor manufacturer has not taken it into account in the sensor design. With a [CoBeam²™ design](#) technique that targets improved front-to-back linearity, a Lin_{FB} of 0.3 to 0.5% can be achieved. For many users, this is sufficient to eliminate any concerns for front-to-back linearity.

In fact, for the CoBeam², the front side linearity is more closely matched to the backside linearity as well. Previously, the front side could achieve 0.5% linearity while the back side was as high as 3% or more. CoBeam² technology enables both sides to achieve better than 0.3% linearity for both front side and back side linearity.

Since CoBeam² provides a substantial improvement to both of these parameters, it simplifies the user's calibration and performance specifications. From front-to-back, both the linearity and the gain are more closely matched than designs that are not optimized for these parameters. This dramatically reduces these two error components.

Conclusion

Pressure sensor suppliers typically have a single method that they use for all products or have sufficient confidence in their test procedure to use the one method to guarantee meeting other specifications. Depending on the product line and requirements, especially of large volume customers, a supplier can change its method of specifying linearity. For custom orders, a supplier may use a completely different method. Typically, the discussed test methods provide the basis for linearity specifications. In addition to standard linearity measurements, for MEMS pressure sensors, users need to be aware of front-to-backside linearity and its impact in their design.

CoBeam²™ is a trademark of All Sensors Corporation.



All Sensors **Pressure Points** are application tips to simplify designing with microelectromechanical (MEMS) pressure sensors and avoiding common pitfalls.

Pressure Point 4: Dual Die Compensation for MEMS Pressure Sensors

Several pressure sensor manufactures promote product incorporating “dual die compensation.” This compensation technique is employed for very low pressure sensors where common mode errors cannot be compensated by any other means for either gage or differential pressure measurements. There are two forms of dual die compensation. One form of dual die compensation incorporates two pressure sensors but only one of the two sensors provides a pressure sensitive output. The second sensor is passive and is used solely to correct for common mode errors. The second form of dual die compensation incorporates two pressure sensors and both sensors provide a pressure sensitive signal. Both these compensation techniques are embodied in patent 6,023,978. This compensation technique applies to all common mode errors and is the only technique available to compensate for long term drift of output offset voltage. Figures 1 and 2 illustrate dual die compensation methods where common mode errors are reduced in comparison to traditional methods. Figure 3 illustrates a reference to traditional sensor construction where common mode errors are not reduced.

Reference Dual Die Compensation using electrical cross coupling:

Figure 1 shows the schematic for passive dual die compensation. The active die provides an output signal proportional to pressure while the reference die is used to virtually eliminate all common mode errors of the active die. This compensation is done by electrically cross coupling the outputs of the two sensors. To provide the highest degree of compensation accuracy the two die are selected as adjacent die on the same wafer. This form of compensation will correct for output signal offset errors associated with long term drift, warm-up drift, and offset drift over temperature. This compensation is used in lieu of active dual die compensation when there are package size limitations and the output signal is acceptable at one-half the single die level. For the lowest pressures, one inch of water or less full scale, generally active dual die compensation is the preferred approach.

Active Dual Die Compensation using pneumatic, fluidic cross coupling and electrical cross coupling:

Active dual die compensation has both electrical cross coupling of the sensors outputs and pneumatic cross coupling of the pressure. In doing both electrical and pneumatic cross coupling the signal strength is not reduced and the common mode error compensation is optimized. This is a result of a double negative multiplier effect. Figure 2 shows how the pneumatic cross coupling is done. For gage pressure measurement ambient pressure is applied to one side of one pressure sensor diaphragm and is also applied to the opposite side of the second pressure sensor diaphragm. The pressure being measured is also pneumatically coupled to the opposite sides of the two pressures sensors from the ambient pressure.

For differential pressure measurements the ambient pressure is replaced by the reference pressure (P2) and result in a differential pressure reading. The pneumatic cross coupling for both gage and differential pressure measurements is done using fluidic channels in the package housing of the pressure sensors.

The active dual die compensation is not only effective in reducing the common mode errors as in the reference dual die configuration but the front to back linearity is also dramatically improved. This is because for any given pressure measurement, the output is the average of one front side measurement and one backside measurement resulting in equal positive pressure and negative pressure sensitivities. This front to back linearity improvement together with the common mode error reduction and full output signal makes this configuration the preferred approach for very low pressure sensing and compensation.

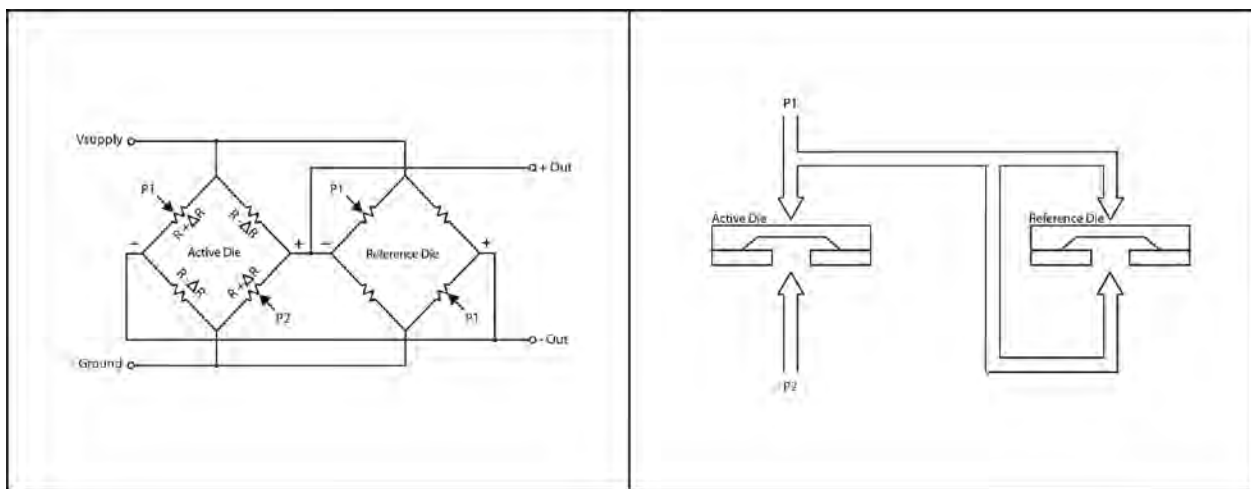

Figure 1

Electrical cross coupling compensation of active die using reference die

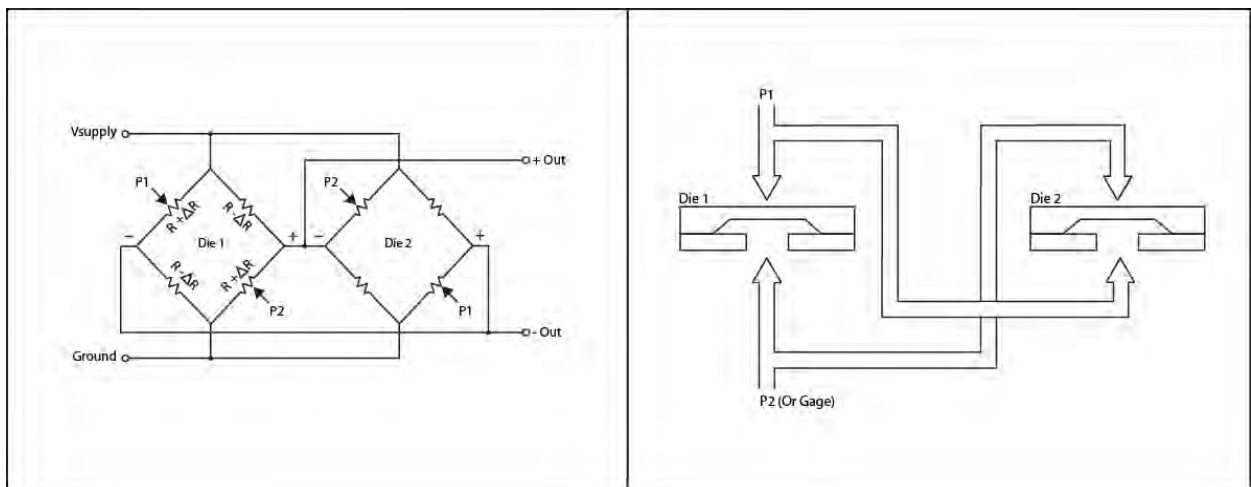

Figure 2

Pneumatic cross coupling compensation using fluidic channels in the pressure sensor package

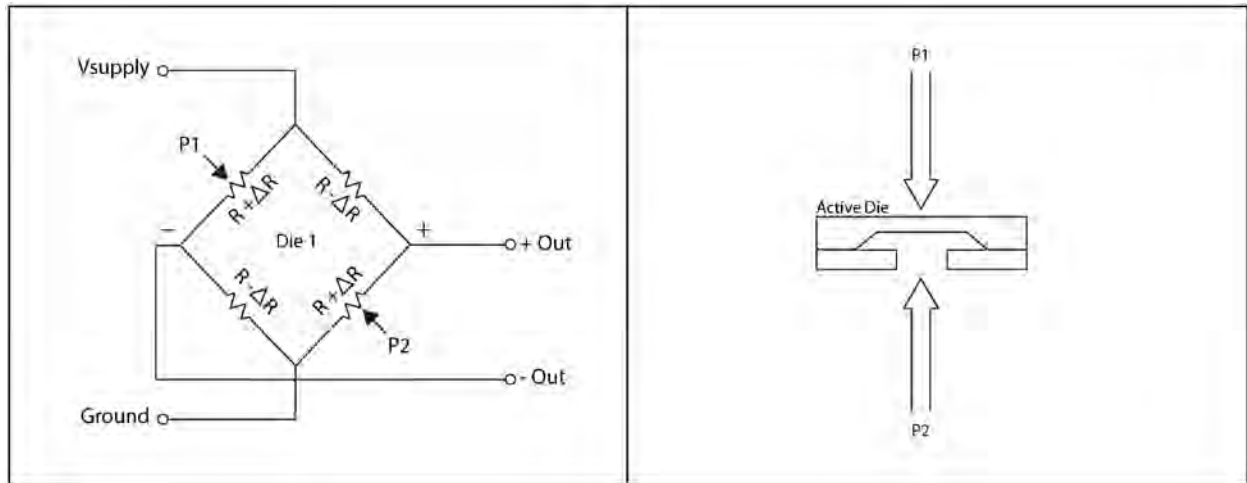

Figure 3
Single Die Configuration

All Sensors **Pressure Points** are application tips to simplify designing with microelectromechanical (MEMS) pressure sensors and avoiding common pitfalls.

Pressure Point 5: Special Considerations for Mounting and Handling Pressure Sensors

Successfully applying a pressure sensor requires more than ensuring that it meets design specifications. Ignoring the sensor supplier’s recommendations for proper handling of the pressure sensor during the user’s manufacturing process can cause both immediate and latent problems. Since the environmental challenges that pressure sensor face in end applications expose them to more hazards than other sensors, users need to be especially careful with these products. This Pressure Point discusses the most common considerations for low pressure (0-150 psi) sensors in plastic packages.

Mounting to Minimize Package Stress

Housed in durable, printed circuit board (PCB) mountable packages, All Sensors pressure sensors are offered in a variety of packages as shown in Figure 1. For screw-attached packages such as Figure 1 a, care should be taken to avoid excessive torque when installing the sensor or its calibration and/or zero may shift. To ensure proper installation torque, the zero shift can be checked after installing. Barbed mounting clips such as the Christmas Tree™ design from [ITW Fastex](http://www.itw.com) can be used for applications under 5 PSI and nylon screws can be used for applications above 5 PSI.

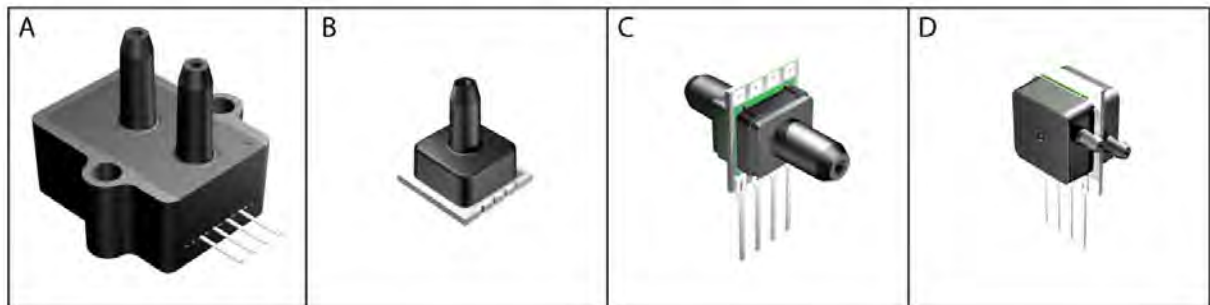

Note: packages not to scale

Figure 1: Package types A,B, C and D from All Sensors require different mounting and handling considerations.

Media Compatibility/Harsh Media Issues

All Sensors pressure sensors are specifically intended for use with non-corrosive, non-ionic working fluids such as air, and dry gases. All Sensors recommends evaluating sensors in their intended environment to determine if added protection from the environment is required.

Pressure Connections

For pressures above 30 psi, barbed ports or threaded connections are typically used to ensure proper pressure sealing. Many of All Sensors pressure sensors target low pressure applications (less than 30 inches H₂O), where a port without a barbed connection is sufficient. The pressure tubing should be fully inserted to avoid vibration from disconnecting the sensor during its usage.

Electrical Attachment

For leaded packages, connectors are available from connector suppliers that allow electrical attachment without making a solder connection. For sensors that are solder attached to a PCB, the maximum temperature limits of the package must not be exceeded.

For amplified sensors in Figure 1 (a and d package types), lead temperature soldering must occur within 2 to 4 seconds and at a maximum temperature of 250°C

For millivolt output sensors in Figure 1 (a package), lead temperature soldering must occur within 2 to 4 seconds and at a maximum temperature of 270°C.

All Sensors BASIC Series of pressure sensors use a ceramic surface mount configuration to provide the smallest footprint possible. For surface mount basic sensors such as Figure 1 b (LP and LF packages), lead temperature soldering must occur within 2 to 4 seconds and at a maximum temperature of 270°C.

Wave soldering and/or surface mount solder reflow requires additional consideration. The recommendations of the “IPC Association Connecting Electronics Industries and JEDEC Moisture/Reflow Sensitivity Classification for Nonhermetic Solid State Surface Mount Devices” (<http://www.ipc.org/TOC/IPC-JEDEC-J-STD-020C.pdf>) can be used to maintain package integrity of components during any heat exposure of board soldering and de-soldering.

Conclusion

With proper consideration to the mounting and handling requirements of MEMS pressure sensors in plastic packages, the end product can experience a long and useful life while operating within the data sheet parameters.

All Sensors **Pressure Points** are application tips to simplify designing with microelectromechanical (MEMS) pressure sensors and avoiding common pitfalls.

Pressure Point #6: Position Sensitivity in Pressure Sensors

Similar to any suspended structure, the thin diaphragm in piezoresistive MEMS pressure sensors is affected by gravitational and other forces. Figure 1 shows gravity applied to the top surface of the sensor. If the sensor's mounting position results in gravitational force applied to the bottom surface, the resulting 2g difference can affect the zero calibration. The thinner the diaphragm, especially in products that sense very low pressure, the greater the sensitivity.

Without appropriate design considerations, the zero calibration shift may be sufficient to cause unacceptable errors in the application with the largest errors occurring when the sensor is mounted opposite to the direction in which it was calibrated. Acceleration forces that exceed 1 g in the application and shock can change the zero output as well without any change in pressure occurring.

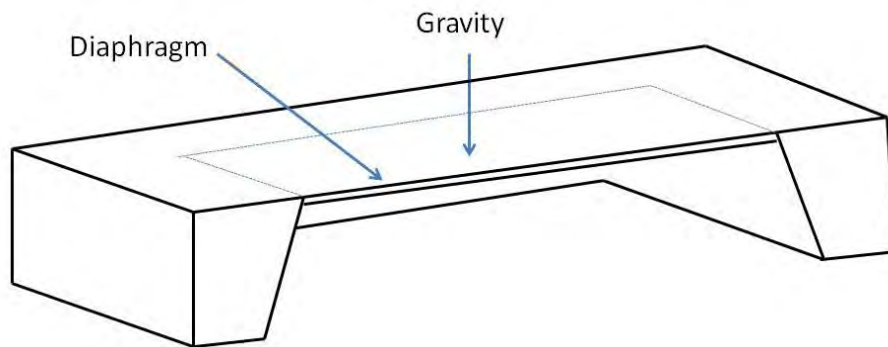

Figure 1. Gravity applied to the top surface of the MEMS pressure sensor results in a force of 1 g applied to the thin diaphragm.

Minimizing Mounting Position Sensitivity

To minimize the affect of gravity and other forces, All Sensors amplified and millivolt output low pressure sensors use a proprietary technology to reduce all output offset or common mode errors. As a result of this design methodology, output offset errors due to change in temperature, stability to warm-up, stability to long time period, and position sensitivity are all significantly reduced when compared to conventional compensation methods.

For example, for All Sensors 1 INCH-Dx-4V-MINI, that has a ratiometric 4-volt output, the Offset Position Sensitivity (within $\pm 1g$) is ± 5 mV, a value less than half of the Offset Warm-up Shift, and Offset Long Term Drift (one year) and much less than the Offset Temperature Shift (from $5^{\circ}C$ to $50^{\circ}C$), that is a maximum of ± 60 mV. Offset Position Sensitivity is less than 0.125% of full scan span.

For the 0.5 INCH-D-MV that has a millivolt level output (10 mV nominal span), the Offset Position Sensitivity (1g) is a maximum ± 5 μV compared to the Offset Warm-up Shift that is a maximum ± 100 μV and Offset Long Term Drift (one year) that is a maximum of ± 200 μV . Offset Position Sensitivity is less than 0.05% of the nominal full scan span.

In both cases, the Offset Position Sensitivity is well within the requirements of most applications and substantially lower than other offset parameters.

Conclusion

Position errors due to mounting location, gravity and external acceleration forces are minimal with All Sensors amplified and millivolt output pressure sensors.

All Sensors **Pressure Points** are application tips to simplify designing with microelectromechanical (MEMS) pressure sensors and avoid common pitfalls.

Pressure Point 7: Understanding Common-Mode Differential Pressure

When pressure sensors are used to measure differential pressure (ΔP) for sensing flow, the common-mode pressure issues need to be considered. This is especially true for applications such as medical instrumentation, environmental controls and heating ventilating and air conditioning (HVAC) systems where All Sensor's low pressure sensors are commonly used.

Just as common-mode errors can occur in an electrical circuit, the common-mode pressure can cause concerns for the pressure measurement. Figure 1 shows the elements of a ΔP flow measurement. Even though the ΔP pressure drop can be quite small, the pressure on the opposite sides of the pressure sensor due to the line pressure can be quite high. Two areas that frequently require additional attention by the supplier and the user are maximum pressure ratings and common-mode pressure errors.

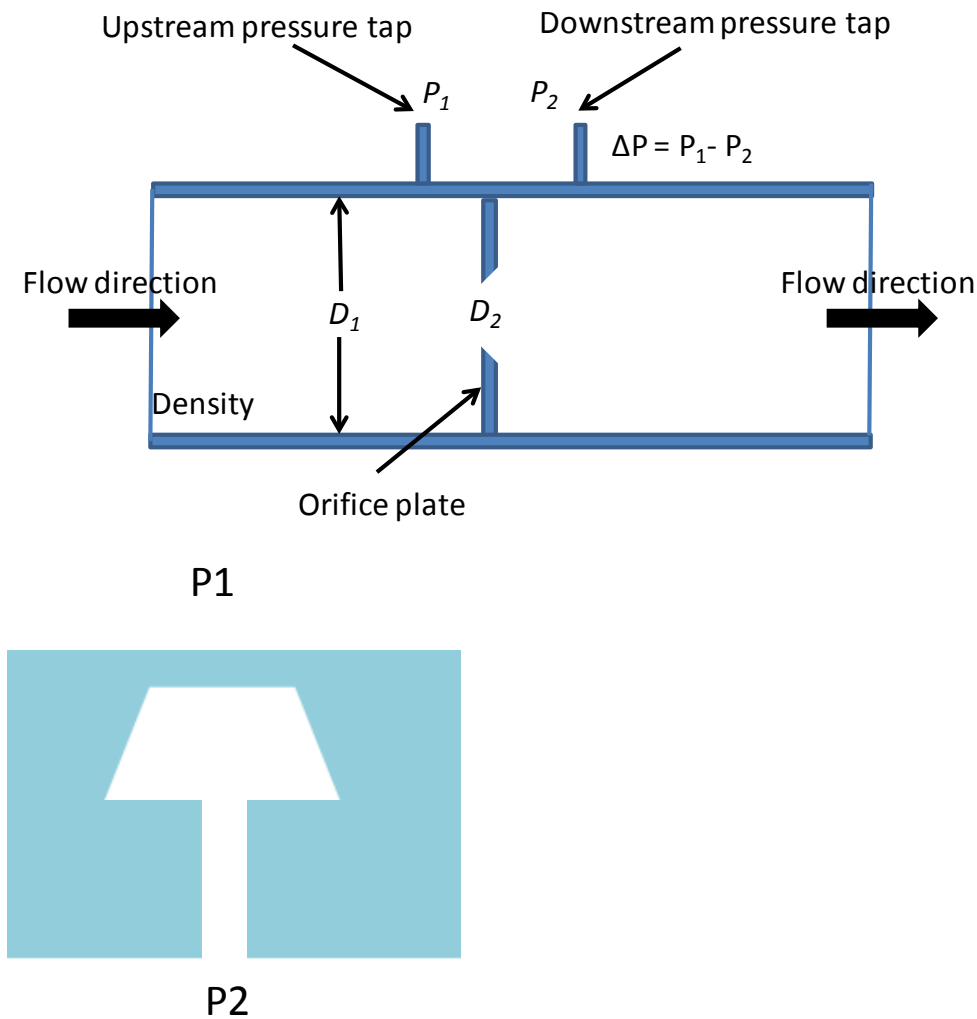

Figure 1. Common-mode pressure concerns in a ΔP flow measurement result from high pressure on both sides of the sensor and the need to make an accurate measurement at a much lower pressure.

Maximum Pressure Ratings

The *common mode pressure rating* is the maximum pressure that may be applied to both sides of the diaphragm simultaneously without causing changes in performance to the specifications.

In a fault situation, such as the loss of the pressure connection on either side of the sensor, the line pressure is applied to only one side of the sensor, so the pressure drop across the diagram increases substantially. To avoid problems including device failure, the line pressure must be below the maximum common-mode, proof and burst pressure ratings.

For example, All Sensors' 1 MBAR-D-4V, a ± 1 In H₂O differential pressure sensor designed for high sensitivity and accuracy has a common-mode pressure rating of -10 to +10 psig (277 times the operating range). The proof pressure is 100 In H₂O (100 times the operating range) and the burst pressure is 200 In H₂O (200 times the operating range).

Reducing Common-Mode Pressure Errors

In addition to differences in the net pressure loading of the sensor's mechanical structure, typical piezoresistive microelectromechanical system (MEMS) pressure sensor design issues include imperfect balance in the bridge transduction resistors, appropriate mechanical side-wall design and a design that reduces diaphragm stress due to common mode pressure. Inadequate attention to these parameters in the design process can result in unacceptable common-mode pressure errors in the application. All Sensors has two approaches to minimize common-mode pressure errors: improved common-mode rejection with the [CoBeam²™ design](#) and dual-die compensation.

All Sensors' [CoBeam²™ design](#) technique targets improved common-mode response and typically achieves a 10x improvement over traditional sensor designs. For many users, this is sufficient to eliminate any concerns for common-mode errors issues in common-mode pressure measurements.

Some of All Sensors pressure sensors are manufactured using a patented technique for compensating piezoresistive pressure sensors: dual-die compensation with electrical cross coupling and pneumatic cross coupling. The pneumatic cross coupling is accomplished using fluidic channels in the package housing of the pressure sensors.

The active dual-die compensation dramatically reduces the common-mode errors. This is because for any given pressure measurement, the output is the average of one front side measurement and one backside measurement resulting in the cancellation of the common-mode error present in each sensor die. This cancellation of the common-mode errors together with the initially lower inherent common-mode error of the [CoBeam²™ design](#) makes the dual-die configuration with the [CoBeam²™ die](#) the preferred approach for very low pressure sensing and compensation. See [Pressure Point 4: Dual Die Compensation for MEMS Pressure Sensors](#) for more details.

Conclusion

Common-mode pressure issues need to be considered by both sensor manufacturers and users. With appropriate attention by the sensor designer, the user's concerns can be greatly simplified.

CoBeam²™ is a trademark of All Sensors Corporation.

All Sensors **Pressure Points** are application tips to simplify designing with microelectromechanical (MEMS) pressure sensors and avoiding common pitfalls.

Pressure Point 8: Bandwidth vs. Signal to Noise Tradeoff

Knowing the pressure range is only one of the criteria for selecting the right pressure sensor.

“What is most often overlooked when selecting a pressure sensor is the bandwidth to signal to noise (S/N) tradeoff,” says Tim Shotter, Director of New Product Development and Applications at All Sensors Corporation. “It is as fundamental a consideration as the gain bandwidth product term when selecting an op amp.”

The tradeoff considerations are especially important in medical and other applications where dynamic signal analysis is performed. As with most analog systems, the greater the bandwidth, the lower the S/N ratio becomes. While this is generally understood, the impact of the compensation method on the bandwidth to S/N curve is less obvious.

As Shotter explains, “In general, a basic sensor (which has no factory compensation), has the greatest potential for the highest performance when viewed in terms of the bandwidth to S/N curve.” However, this design approach also has the greatest cost and effort to amplify, calibrate and compensate for temperature effects.

To solve the problem, users cannot settle for the standard amplification that most MEMS pressure sensor companies supply. In most cases, for high performance applications, users will have to perform the amplification and signal conditioning themselves to get the performance they need. An All Sensors solution to this problem is provided in its [BLVR Series Basic](#) series and [Low Pressure Millivolt Output](#) family.

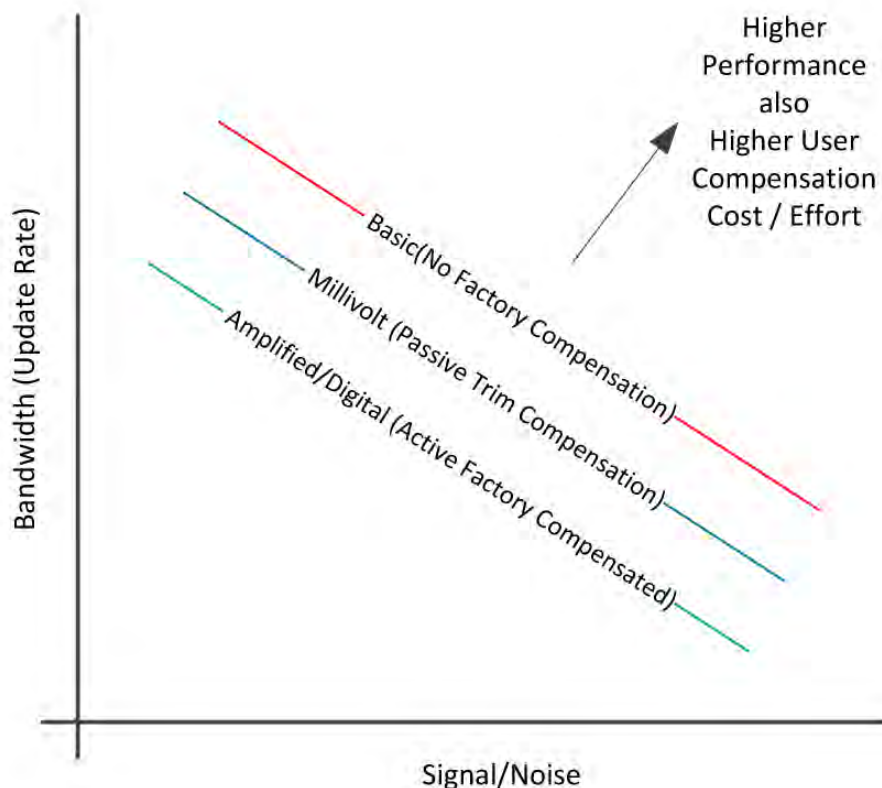

Figure 1: To get the highest performance for bandwidth and S/N, users may have to tradeoff an amplified version provided by the supplier and develop their own additional circuitry. Alternative pressure sensor products, such as All Sensors' Millivolt and Basic series (shown) provide an improved starting point.

General purpose amplified and digital sensors offer excellent calibration and thermal compensation however their S/N tends to be lower (compared to a Basic or Millivolt sensor) due to the use of lower power op amps and quantization noise. "Also, digital devices may suffer from factory prescribed update rates (bandwidth) which may or may not follow the application requirement unless the factory includes appropriate options for the update rate," says Shotter.

A trimmed Millivolt sensor has good compromise when considering the bandwidth to S/N. In this case, the part only needs user provided amplification and the amplifier noise can be tailored to the application. The output level of the Millivolt sensor is generally lower than a basic sensor, so the overall S/N curve is impacted compared to a Basic sensor even if the same op amp is used for both.

Targeting medical applications and others, All Sensor's BLVR Series Basic Sensor and Low Pressure Millivolt Output products are based on a dual die technology to reduce all output offset or common mode errors. Both series also incorporate another sensor-level design technology to reduce the overall supply voltage while maintaining comparable output levels to traditional equivalent basic sensing elements. The Low Pressure Millivolt Output family addresses 0 to 0.5" H₂O to 0 to 30" H₂O pressure ranges and the BLVR Series Basic Sensor series covers 0 to 1" H₂O to 0 to 30" H₂O pressure ranges.

Originally published in Design World May 2013, "Solving Medical Sensing Application Problems"

All Sensors **Pressure Points** are application tips to simplify designing with microelectromechanical systems (MEMS) pressure sensors and avoid common pitfalls.

Pressure Point #9: Pressure Sensor Technologies

System designers have many choices when it comes to selecting a technique for measuring pressure. Microelectromechanical systems (MEMS) technology is widely discussed and implemented for numerous sensing applications. For pressure measurements, there are several other technologies, many that are not well known or commonly used today.

Techniques for Measuring Pressure

In [Global Pressure Sensor Market 2012 - 2017: Forecast, Trend & Analysis - Segmentation by Technology, Applications & Geography](#), analysts at Research and Markets report that 8.7 billion pressure sensors shipped in 2011 and expect the level to reach 16.37 billion units by 2017, at an estimated compound average growth rate (CAGR) of 11.3% from 2012 to 2017. During this same period, the market size is expect to grow at an estimated CAGR of 6.3%.

With billions of units being sold, there are wide extremes in the devices offered for sensing pressure. Criteria for selecting a specific technology can include whether the sensor is used for flow, liquid level, depth, altitude or barometric measurements. In addition, the need for absolute verses gauge or differential technology can help determine the technology choice as well. (See [Pressure Point #1](#) for more details.)

Two essential aspects of any pressure sensing device are a force collector and transducer technology. In the earliest pressure measurements, the transducer technique converted pressure into mechanical motion of a gauge or height of a liquid column. Aneroid cells, Bourdon tubes, bellows, diaphragms, deadweight testers and manometers provide the historical basis for the force collector in many pressure measurements. New semiconductor methods have been applied to previous vacuum sensing technology such as the Pirani gage (thermal conductivity) device.

Some of these technologies are used for high pressure measurements. Some are used for very low pressure measurements, such as the McLeod gauge or Pirani gauge which apply to vacuum measurements (i.e. ionization gauges). System engineers with applications in these areas should investigate these alternate technologies more closely.

Converting Pressure into an Electrical Signal

With sensing playing an active role in modern control systems, pressure sensors must provide more than a readout for monitoring. The need for an electrical output that can provide feedback in a control system is solved by the following sensing techniques:

- Capacitive
- Magnetic, such as a linear variable differential transformer (LVDT)
- Optical
- Piezoelectric
- Piezoresistive
- Potentiometric/Resistive

- Resonant frequency

Some of these techniques address specific applications such as sensing very high pressure (i.e., fiberoptic technology) or the high precision and accuracy requirement of instrument grade sensors.

MEMS Technology for Sensing Pressure

Today, sensor experts estimate that MEMS technology is used in over 90% of the pressure sensors. Piezoresistive and capacitive sensing are commonly used in MEMS-based pressure sensors.

In the [Global MEMS Pressure Sensors Market 2012-2016 report](#) from TechNavio, analysts project the global MEMS pressure sensors market to grow at a CAGR of 8.84% over the period 2012-2016.

With their small size and small external packaging, MEMS sensors of all types have created new applications and provided new features in many end products. In addition, semiconductor manufacturing provides consistency high yields, low cost and a path to even lower cost.

For pressure measurements, piezoresistive bulk micromachined sensors are most commonly used technology due to the ease of signal conditioning, broad selection and low cost. These MEMS sensors are used in most common pressure ranges from 0-4 in to 0 to 100 psi. Advancements, such as All Sensors' CoBeam²™ technology improve the force collector capability of piezoresistive sensors. This allows piezoresistive MEMS sensors to achieve a high level of pressure sensitivity, especially in lower pressure applications, without increasing the die size or using costly boss structures.

Application Choices

There are many technologies available for sensing pressure but the choices narrow for specific applications. For low cost measurements in the 0-4 in to 0 to 100 psi ranges, the capabilities of piezoresistive MEMS-based sensors should be considered.

Cobeam² is a trademark of All Sensors Corporation

All Sensors **Pressure Points** are application tips to simplify designing with microelectromechanical systems (MEMS) pressure sensors and avoiding common pitfalls.

Pressure Point 10: Media Capability

Harsh media poses one of the most significant application problems for most pressure sensors. Pressure sensors measuring flow (liquids or gases) and/or liquid depth and that interface to a variety of chemicals can present the most serious challenges but, in some instances, even exposure to water can compromise the sensor's durability.

Sensor manufacturers are usually well aware of the limitations of their products in this critical area. Typical manufacturers' responses are: to provide warnings regarding applications that are strictly not recommended; to provide recommendations for approaches that users can implement to overcome these limitations; and to implement unique packaging that makes the sensor capable of withstanding a selected or several harsh media situations.

Harsh Media Packaging

The use of stainless steel packaging, especially for the sensor diaphragm and the use of other highly durable materials for other packaging aspects can make a sensor suitable for many harsh applications. These sensors solve the harsh environment requirement at a cost that would be prohibitive in most other environments. However, for those applications that require harsh media capability, the cost is quite justified.

Techniques to Improve Media Compatibility

Protective diaphragms made of silicone or other materials and conformal coatings such as Parylene or fluoropolymers are common approaches that sensor manufacturers either implement themselves, frequently as options, or recommend to users. These techniques provide a means to make their product more likely to survive and withstand the rigors of some applications.

If the sensor manufacturer provides this protection, the added materials and assembly effort increases the cost. If users implement these recommendations, the responsibility for product lifetime is solely their responsibility. In addition, the response time of the sensor may be reduced and other sensor parameters could be affected by the addition of the protective technology. Since the sensor manufacturer has no control over the impact implementation of the protection technique, the user must evaluate the protected device for secondary effects. These are just two considerations for users who choose to provide their own protection.

Limiting the Applications to Manufacturer's Recommendations

For pressure sensor manufacturers to offer the highest volume and most cost-effective sensors, plastic packaging is the most commonly used packaging material. Ceramic substrates provide added capability. In either case, the compatibility of these and other exposed packaging materials to those found in the operating environment provides a basis for sensor manufacturers to recommend or not recommend their sensors for specific applications.

All Sensors pressure sensors are specifically intended for use with non-corrosive, non-ionic working fluids such as air, and dry gases. All Sensors recommends evaluating sensors in their intended environment to determine if added protection from the environment is required.

Successful applications require end users to avoid interface materials that would compromise or interact with any of the sensor's packaging materials. For piezoresistive, microelectromechanical system (MEMS) sensors, the most common material after the plastic packaging is the silicon that provides the sensor's diaphragm, supporting foundation and working surface for piezoresistors and other electronics. Other packaging materials can include protective gel coatings that have limited media capability and mounting materials that can include glass, silicone rubber or other materials. Silicone gel coatings can typically be used down to pressures as low as 5 PSI as long as the sensor manufacturer's recommendations are followed. (See Figure 1.) Parylene can be used to pressures as low as 5 inches of water without incurring problems as the sensor manufacturer's recommendations are followed. (See Figure 2.)

Figure 1. The cross section and typical materials of plastic-packaged MEMS pressure sensors.

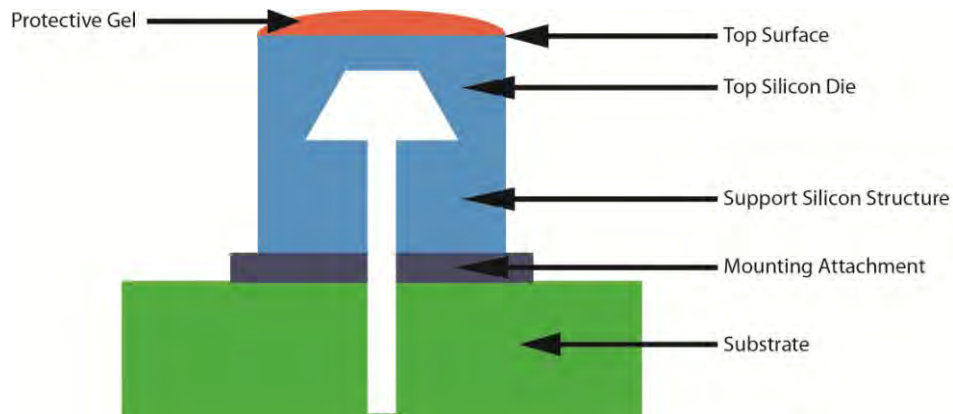
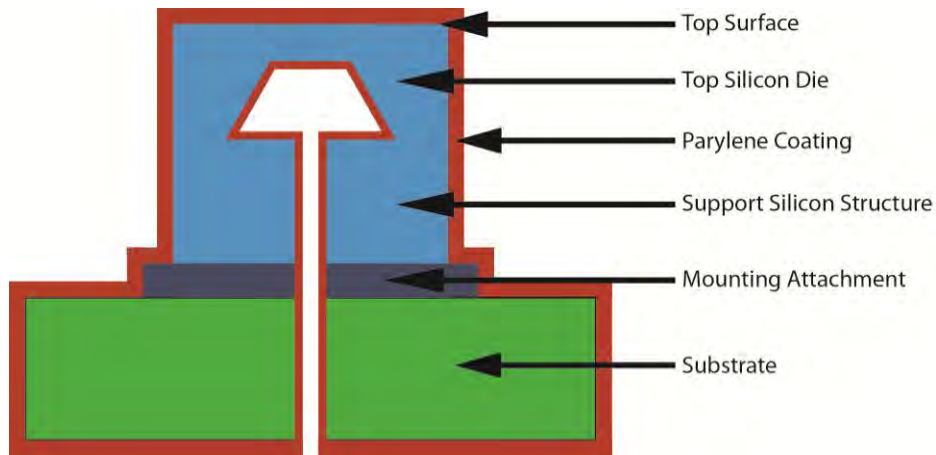

Figure 2. The cross section and typical materials of plastic-packaged MEMS pressure sensors coated with Parylene.



One technique that minimizes the exposure of the more susceptible top surface of the sensor is applying pressure to the back side. Users should be aware that manufacturers typically test and ensure conformance only to product specifications when pressure is applied to the top surface. If the supplier tests one side and the customer uses the opposite side, the performance can be quite different. In addition to sensitivity, the linearity can be directly impacted as well. (See Pressure Point 3: Linearity for MEMS Pressure Sensors for more details.)

To avoid problems in this area and provide a more media-compatible pressure sensor, All Sensors' pioneered its CoBeam2™ design technique. Front-to-back linearity (LinFB) can have as much as a 7 to 8% difference if the sensor manufacturer has not taken it into account in the sensor design. With a CoBeam2™ design technique that targets improved front-to-back linearity, a LinFB of 0.3 to 0.5% can be achieved. For many users, this is sufficient to eliminate any concerns for front-to-back linearity. With CoBeam2™ design technology, pressure sensors users can address more commonly encountered media in high volume/low cost applications and avoid front-to-back linearity issues.

All Sensors **Pressure Points** are application tips to simplify designing with microelectromechanical systems (MEMS) pressure sensors and avoiding common pitfalls.

Pressure Point 11: Calculating Flow Rate from Pressure Measurements

Fluid flow occurs with the motion of liquid and gaseous materials and pressure sensors play a critical role in determining many aspects of fluid flow. Fluid dynamics provides the means of understanding the parameters that impact fluid flow. The active links in the following sections provide more details.

Basic Fluid Dynamics Concepts

Reynolds number (Re) is a dimensionless velocity value used to predict flow patterns. It is [a function of](#) the inertia force ($\rho u L$), and the viscous or friction force (μ).

[Viscous vs. Nonviscous Flow](#)

Viscous flow results in energy loss (and subsequently a temperature rise) but ideal fluids have nonviscous flow with no energy loss.

Laminar (Steady) vs. Turbulent Flow

In laminar flow, the particle motion is very uniform/orderly and results in straight lines parallel to the enclosure's walls and is very predictable. With turbulent flow, random motion can result in eddies and other less predictable behavior. A [mixture of laminar and turbulent flow](#), called [transitional flow](#), occurs in pipes and other enclosures with turbulence in the center of the enclosure, and laminar flow near the edges. More viscous fluids tend to have laminar flow and a lower Reynolds number.

Compressible or Incompressible Flow

Unlike [compressible flow](#) where the density changes with the applied pressure, with incompressible flow, the density is constant in space and time.

Bernoulli's Equation is used to determine fluid velocities through pressure measurements. It starts with qualifications of nonviscous, steady, incompressible flow at a constant temperature.

$$P + \frac{1}{2}\rho v^2 + \rho g y = \text{constant}$$

P = pressure

v = velocity

ρ = density of the fluid

g = gravity

y = height

The Venturi effect is increase in velocity that occurs when fluid flow is restricted. The Venturi meter is an application of Bernoulli's equation. Common types of restrictions include orifice plates, Venturi tubes, nozzles and any structure that has an easily measured pressure differential.

[Flow in a Pipe/Tube](#). Several factors determine the pressure drop that occurs in fluid flow applications including laminar versus turbulent flow, the flow velocity, kinematic viscosity and Reynolds number of the fluid, internal roughness of the inside of the pipe as well as its diameter, length and form factor. [Orifice plates, Venturi tubes and nozzles](#) simplify the situation. In these cases (refer to Figure 1), the flow is related to ΔP ($P_1 - P_2$) by the equation:

$$q = c_d \pi/4 D_2^2 [2(P_1 - P_2) / \rho(1 - d^4)]^{1/2}$$

Where:

q is the flow in m³/s

c_d is the discharge coefficient, the area ratio = A₂ / A₁

P₁ and P₂ are in N/m²

ρ is the fluid density in kg/m³

D₂ is the orifice, venturi or nozzle inside diameter (in m)

p₁"> D₁ is the upstream and downstream pipe diameter (in m)

and d = D₂ / D₁ diameter ratio

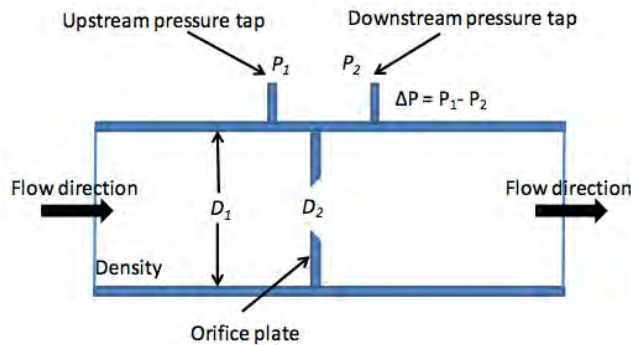

Figure 1. Elements of a ΔP flow measurement.

Pitot tubes use the difference between total pressure and static pressure to calculate the velocity of the aircraft or fluid flowing in the pipe or enclosure. A Pitot-static tube for measuring aircraft velocity is shown in [Figure 2](#).

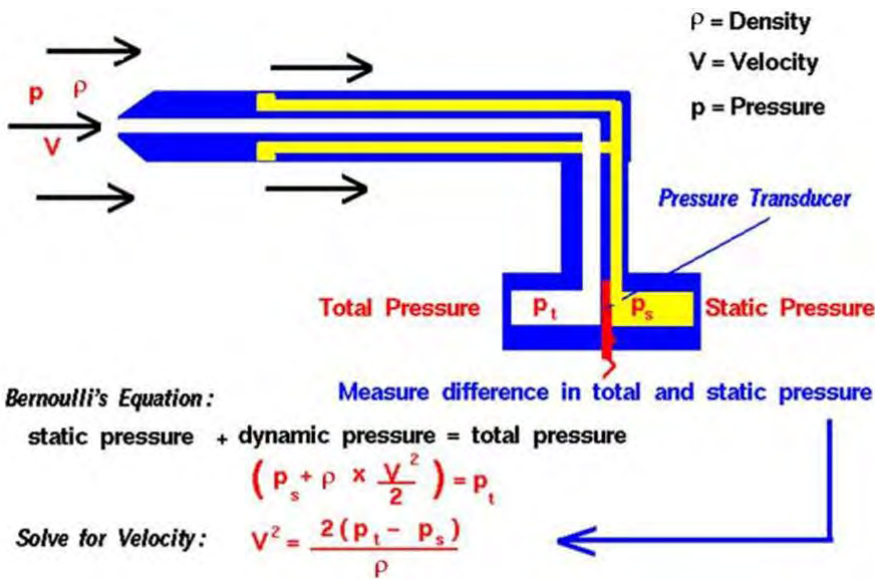

Figure 2. A Pitot-static or Prandtl tube used to measure aircraft velocity.

[Water hammer](#) is the shock caused by the sudden decrease in velocity of a flowing fluid and the time it takes for the pressure wave for round trip travel in the pipe. The [Joukowski impulse equation](#) is used to calculate the resulting pressure when the liquid velocity that drops to zero upon contacting a closed valve.

$$\Delta P = \rho \cdot c \cdot \Delta V$$

In psf

For rigid pipes, the celerity of the pressure wave or wave speed, c , is found by:

$$c = \sqrt{E_b / \rho}$$

where E_b is the bulk modulus of fluid in psf and ρ is the density of the fluid.

Measurements in Specific Applications

In the medical area, respiratory issues require airflow [measurements for ventilator](#) flow/control, and analysis, such as [spirometers](#), as well as gas and liquid flow measurements for treatment. For example, the differential pressure in a spirometer or respirator is nominally 4 kPa and in a ventilator, it is nominally 25 cm H₂O. In either case, the values are quite low and the pressure measurement requires special consideration in the pressure sensor to achieve the desired accuracy and precision.

HVAC

Clean and low power consumption in heating, ventilation and air conditioning (HVAC) systems require the proper air filters and frequently monitoring to identify a filter that requires changing. Normal operating pressures are typically in the range of 0.1 to 1" H₂O. The American Society of Heating, Refrigerating and Air-Conditioning Engineers' (ASHRAE's) minimum efficiency reporting value, or [MERV](#) rating, measures the effectiveness of air filters. [Sensing the pressure drop across an air filter](#) minimizes unnecessary power consumption by motors.

Tools for Fluid Calculations and Simulation

Online calculations tools from [efunda](#), [KAHN](#), [LMNO Engineering](#), [valvias](#), [Pressure Drop Online-Calculator](#) and others can provide some quick tools to implement the calculations shown previously. In addition, several companies offer advanced simulation tools for computational fluid dynamics and consulting services to delve much deeper into the more sophisticated and complex issues involved with fluid flow, including: [ANSYS](#), [Applied Flow Technology](#), [Autodesk](#), [MathWorks](#), [SOLIDWORKS](#), and others.

All Sensors **Pressure Points** are application tips to simplify designing with microelectromechanical systems (MEMS) pressure sensors and avoiding common pitfalls.

Pressure Point 12: Making MEMS Pressure Sensors Easier to Use (Part 1)

Pressure is one of the most common measurements. Based on their small size, low cost and high reliability, microelectromechanical systems (MEMS) pressure sensors that use the high-volume manufacturing techniques of the semiconductor industry are found in over 90% of today's applications.

It could be said that there are two types of pressure measurements: those that are made using a MEMS pressure sensor and those that will be. In either case, pressure sensors that are easier to use help designers of products for new or existing applications get their products to market faster. Pressure sensors with a digital output and an evaluation board have two aspects that make design-ins easier. Providing comparative data on two popular MEMS pressure sensors, this two-part white paper will show how pressure sensors with sigma-delta ($\Delta\Sigma$) analog to digital converters (ADCs) (Part 1) and a sensor evaluation kit (Part 2) simplify design-ins.

Analog Pressure Output to Digital Input for Control

MEMS pressure sensors inherently provide a highly linear output that requires amplification and temperature compensation to work in most analog systems. For digital systems, conversion of such analog voltage signal to a digital code is also required. The core component for the interface between analog physical world and digital information domain is an analog to digital converter or ADC.

The ADC converts an input analog voltage signal into a digital code determined in relation to second known signal, the reference voltage. As a result, the sole purpose of ADC is to work as a comparator of an unknown signal to a known reference, with the results provided in digital code.

Due to the discrete nature of digital code, all ADCs apply quantization to the input signal to obtain a finite number of digital codes. Because analog signals have an infinite number of steps, an infinite amount of digital code would be required to represent 100% of the signal. As a result, limiting the input scale to some predetermined levels, and splitting it to small steps is required to represent the input signal with a close approximation. The common definition for minimum digital code step size for a specific ADC is resolution, and it is represented in bits. An ideal 1-bit ADC will generate a "1" when the input analog signal larger than 50% of the range, and a "0" if it is less. An 8-bit ADC has $2^8 = 256$ steps, thus it is possible to determine $100\% / 256 = 0.390625\%$ change of the range. If the range limits are between 0.0V and 10.0V, the ADC can resolve input analog signals with 39.0625 mV dc per 1 bit of digital code output.

Increased resolution reduces this minimal step size. In the example of 10.0V range ADC, 16-bit solution will provide $10.0V / 2^{16} = 10.0V / 65536 = 152.588 \mu V/\text{bit}$.

The simplest ADC systems without any additional amplifiers or attenuators have an input range equal to the known reference voltage signal. Many modern ADCs have also integrated amplifiers and front-end circuits to allow multiple ranges from single known reference voltage.

Important Note on ADC Resolution

Resolution of the ADC is often confused and mistaken with accuracy, but actually these two parameters are almost unrelated. Higher resolution does not provide better accuracy; it only provides a smaller digital step size. Together with the input signal range, resolution provides the sensitivity of the ADC.

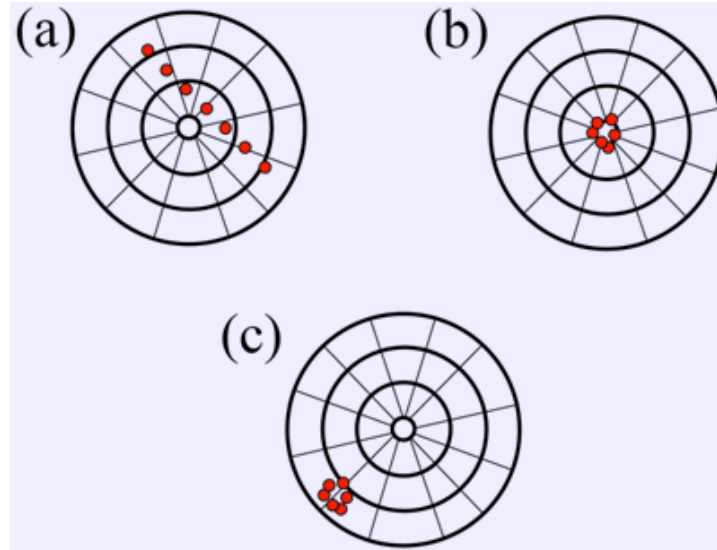

Figure 1. Accuracy versus resolution representation

Case **(a)** represents low resolution and low accuracy, with samples all over the place. The true signal value cannot readily be observed. Improvement on both resolution and accuracy will get sample distribution such as case **(b)**. This is high resolution *with* high accuracy. With high resolution and low system accuracy, the results will be case **(c)**. This is why calibration often more important than resolution for high-precision equipment, since even if it has high precision, it does not necessarily provide good accuracy.

There are many cases when 24-bit ADC provides worse accuracy than better 16-bit device. So, resolution provides a theoretical sensitivity level, in terms of the smallest digital code difference, while accuracy is derived from a complex mix of many actual ADC design parameters, such as front-end stability, temperature coefficients of amplifiers/voltage references, calibration and compensation correction and noise isolation from other components of the system.

An example, using 0-10 V range 8-bit and 16-bit theoretical ADCs, converts a 5.000 V analog signal into digital code, but this time with one extra variable. In case A, the voltage reference (known voltage against which ADC compare input signal) is precisely 10.0000 V, while in the second case B, there is 100 mV error in the voltage reference, so the true reference voltage is 10.1000 V.

Parameter	8-bit "A" ADC	8-bit "B" ADC	16-bit "A" ADC	16-bit "B" ADC
Input signal, V_{IN}	5.0000 V	5.0000 V	5.0000 V	5.0000 V
1 bit step size	0.0391 V	0.0391 V	0.0001525 V	0.0001525 V
Reference signal, V_{REF}	10.0000 V	10.1000 V	10.0000 V	10.1000 V
Reference error	0	0.1000 V	0	0.1000 V
Conversion result	$2^8 * (V_{IN} / V_{REF})$	$2^8 * (V_{IN} / V_{REF})$	$2^{16} * (V_{IN} / V_{REF})$	$2^{16} * (V_{IN} / V_{REF})$
Output digital code	0x80 or 1000 0000'b	0x7E or 0111 1110'b	0x8000	0x7EBB
Output error	0	2 bits or 0.1562 V	0	650 bits or 0.09912 V

Table 1. Reference error impact on 8-bit and 16-bit ADC

As this example shows, the error in the reference signal causes output digital code error, unrelated to how many bits of resolution are available. There are multiple sources of errors, many of which reside in the analog domain, and are affected by input signal properties, operation temperature, proximity to other devices on the board, power delivery quality and even mechanical stress to the board.

It is important to keep the reference voltage only slightly higher than maximum expected input signal level. To illustrate this condition, imagine the use of an 8-bit ADC from the example above with 10.0000 VDC reference voltage, when input signal levels are 0 to 0.1V. This is only 1% of the actual ADC range, since $(0.1 V_{IN} / 10.0 V_{REF}) * 100\% = 1\%$. This essentially makes an 8-bit with such a reference range useless, since the output code resolution is just 2.56 bits, providing next transfer function:

8-bit ADC Input voltage ($V_{REF} = 10.000\text{ V}$)	8-bit ADC Output code	Ideal error
0.000 V	0x00	0
0.010 V	0x00	100%, cannot detect signal
0.020 V	0x00	100%, cannot detect signal
0.030 V	0x00	100%, cannot detect signal
0.040 V	0x01 (Threshold level = 0.0391 V)	-2.34%
0.050 V	0x01 (Threshold level = 0.0391 V)	-21.88%
0.060 V	0x01 (Threshold level = 0.0391 V)	-34.90%
0.070 V	0x01 (Threshold level = 0.0391 V)	-44.20%
0.080 V	0x02 (Threshold level = 0.0782 V)	-2.34%
0.090 V	0x02 (Threshold level = 0.0782 V)	-13.19%
0.100 V	0x02 (Threshold level = 0.0782 V)	-21.88%

Table 2. Low-level signal measurement with 8-bit ADC and high V_{REF}

Obviously, such a system is not suitable for such a low signal measurement and needs either a higher resolution ADC or signal amplification circuitry to bring the input close to the full-scale ADC range (which is 10.000 V, due to the used voltage reference V_{REF}).

However, smarter solution is often possible. The output resolution and accuracy can be increased by reducing the reference voltage to match the input signal voltage closer. An ADC may allow external voltage reference use, and allow low voltage reference levels. Reducing the reference voltage is functionally equivalent to amplifying the input signal, however, no amplifier or additional hardware-level components are required. Therefore, reducing the reference voltage is often used to increase the resolution at the input, keeping in mind LSB voltage larger than errors from design and own ADC implementation. (**LSB size** – minimal voltage step size for each code, equal to **Reference voltage / 2^N** .)

Care needs to be exercised, since the voltage reference cannot be decreased too much, as other effects such as thermal noise of the inputs, gain and offset errors, non-linearity and thermoelectric voltages becoming an issue, and these contributors are independent of the reference voltage.

Looking at the same example with reduced V_{REF} to **0.1500 V** allows the use of most of the reduced input range and obtains much better sensitivity over the test 0.000V – 0.100 V signal. An interactive sensitivity calculator is presented in the form and table below, with V_{REF} as a known reference voltage.

V_{ADC} sensitivity calculator	
V_{REF} , reference voltage	<input type="text" value="0.1500"/> V
ADC resolution, 2^N	N = <input type="text" value="8"/> bits
LSB size, calculated	585.93750 μ V

The same test values are used in the table below, but this time with a low reference voltage.

8-bit ADC Input voltage ($V_{REF} = 0.150 \text{ V}$)	8-bit ADC Output code	Ideal error
0.000 V	0x00	0
0.010 V	0x11 (0.00996 V)	-0.39%
0.020 V	0x22 (0.01992 V)	
0.030 V	0x33 (0.02988 V)	
0.040 V	0x44 (0.03984 V)	
0.050 V	0x55 (0.04980 V)	
0.060 V	0x66 (0.05977 V)	
0.070 V	0x77 (0.06972 V)	
0.080 V	0x88 (0.07969 V)	
0.090 V	0x99 (0.08965 V)	
0.100 V	0xAA (0.09961 V)	

Table 3. Low-level signal measurement with 8-bit ADC and reduced VREF

With a 0.15V input reference voltage, the design can use even an 8-bit ADC with better than 1% accuracy in an ideal case. So, choosing correct reference level and range is very important for optimal performance of the analog to digital conversion system.

If the reference level cannot be reduced to match input signal range, it is necessary to amplify low level signals so a similar increase of the voltage resolution can be achieved. The alternative is to use a more expensive, higher resolution ADC. In the same example system with $V_{REF} = 10.000 \text{ V}$ as above, at least a 16-bit ADC would be required to achieve the same theoretical accuracy.

16-bit ADC Input voltage ($V_{REF} = 10.000\text{ V}$)	16-bit ADC Output code	Ideal error
0.000 V	0x0000	0
0.010 V	0x0041 (0.00992 V)	-0.82%
0.020 V	0x0083 (0.01999 V)	-0.05%
0.030 V	0x00C4 (0.02991 V)	-0.31%
0.040 V	0x0106 (0.03998 V)	-0.05%
0.050 V	0x0147 (0.04990 V)	-0.21%
0.060 V	0x0189 (0.05997 V)	-0.05%
0.070 V	0x01CA (0.06989 V)	-0.16%
0.080 V	0x020C (0.07996 V)	-0.05%
0.090 V	0x024D (0.08987 V)	-0.14%
0.100 V	0x028F (0.09995 V)	-0.05%

Table 4. Low-level signal measurement with more expensive 16-bit ADC and high V_{REF}

These resolution-depending errors are quantization limits of an ideal linear ADC. With real hardware, any gain, nonlinearity and offset errors must be added. This is the reason why all common multimeters have multiple ranges, instead of one combined 0V – 1000V range. Multimeters with an autorange feature still have the same design, but perform an automatic selection of the best range depending on input signal.

These application challenges are well recognized by leading ADC manufacturers that spend a significant amount of R&D resources to reduce the impact of all these error contributors on overall output accuracy by using better packaging, isolation, and better stability parts in the design. As result, knowledge and

design features also improved performance, so added digital resolution is useful in many applications. Resolution is relatively cheap to add, but it is important to understand that it is not the resolution alone that makes a higher accuracy ADC.

Most modern ADCs have low voltage power supply requirements, matching typical +3.3V or +5V digital systems supply rails. As result, the reference voltages also have typical levels at 2.500, 2.048, 3.000, 4.096 VDC. To measure signal levels higher than these values, attenuation and front-end scaling is required. Lower voltage levels are helpful for compact battery-powered devices and allow simple interfacing with a typical CMOS microcontroller, digital signal processor (DSP) or digital bus. Many $\Delta\Sigma$ ADCs and feature-rich SAR ADCs have integrated on-chip voltage reference sources, front-end amplifiers, switching, even temperature sensors as well, essentially making nearly complete measurement system on compact single chip package.

There are different types of ADC designs depends on target application requirements and operation principle. Table below presents some most common types, their basic performance parameters and their strong/weak sides.

ADC Type	Flash	Delta-Sigma $\Delta\Sigma$	Integrating (slope)	Successive approximation (SAR)
Operation principle	Parallel comparator array	Oversampling with digital filtering	Integration vs known reference charges	Binary search comparison
Speed	Very fast (up to few GHz)	Slow (Hz) to Fast (few MHz)	Very slow (mHz) to Medium (kHz)	Medium (kHz) – Fast (few MHz)
Resolution	Low, <14bit	Medium to very high, 12-32 bit	Can be very high, 32 bits	8 – 20 bit
Power	Very high	Low	Low-High	Low-Medium
Noise immunity	Low	Medium-High	High	Medium
Design complexity	High	Low	High	Low
Implementation cost	High	Low	Medium to very high for precision	Low

Table 5. Types of ADC designs and performance limitations

Correct ADC type choice is key importance for best results in specific applications. Common pressure sensor applications operate with low bandwidth due to relatively large volumes of measured flow/mass,

typical choice are ADC types like SAR, Delta-Sigma and less often Integrating type. Other designs, for example high-speed oscilloscope need to use flash or pipeline ADCs with high bandwidth.

ADC of same type also may have very different packages, and different levels of integration. Larger packages often can have integrated reference blocks, temperature sensors, input channel multiplexers, programmable current sources for sensor excitation. Often ADC block is also integrated part of bigger system on chip (SOC) system to further save space, however accuracy and resolution of such converters often inferior to discrete ADC designs. Resolution of ADC inside SOCs is usually 12-16 bit with just few exceptions on specialized instrumentation solutions.

Sensors with an Integral ADC

To simplify the use of an analog sensor in digital systems, some sensor manufacturers offer sensors with an integral ADC. A comparison of test results is shown later in this report. Table 6 shows the sensors from All Sensors Corporation (ASC) and another supplier and Table 7 shows their key specifications. This includes the effective number of bits (ENOB) resolution and the total error band (TEB), which typically provides the most important “accuracy” for many applications.

Sensor	TEB
All Sensors DLHR-L10D	±0.75%
All Sensors DLHR-L02D	±0.75%
All Sensors DLHR-L01D	±1.00%
Supplier X Product 1	±2.0%
Supplier X Product 2	±1.0%

Table 6. Pressure sensors with digital front-end selected for test

Parameter	DLHR-L10D	DLHR-L02D	DLHR-L01D	Product 1	Product 2
Pressure range	Diff., ± 10 inH ² O	Diff., ± 2 inH ² O	Diff., ± 1 inH ² O	Diff., ± 20 inH ² O	Diff., ± 2 inH ² O
Sensor die configuration	5-resistor bridge, 2×2mm proprietary die			4-resistor bridge, 2.5×2.5mm proprietary	
ADC Type	16/17/18-bit Δ - Σ			24-bit Δ - Σ	
DSP	YES			NO	
TEB	$\pm 0.75\%$	$\pm 0.75\%$	$\pm 1.00\%$	$\pm 1.0\%$	$\pm 2.0\%$
Output rate	15 to 270 SPS			20 SPS to 2000 SPS	
Typical ENOB min. speed	17 bits			18 bits	16 bits
	16 SPS			20 SPS	
INL				± 15 ppm of FSR (ADC)	
Power requirements	Single, 1.68 – 3.63 VDC			Single, 2.3 – 5.5 VDC	
Onboard temperature sensor	Yes, 16 bits			Yes, 14 bits	
Temperature range	-25°C to +85°C			-40°C to +85°C	
Digital interface	I ² C, SPI			SPI	
One off reference price (DigiKey/Mouser)	\$53.04 USD			\$57.61 USD	

Table 7. Specification comparison of evaluated pressure sensors

Disregarding the output data resolution, the accuracy (TEB) specifications differ significantly. This confirms earlier theory, that the accuracy of the pressure sensor is a system measurement, not depending on ADC resolution.

The All Sensors Difference

Since it is not easy to compensate silicon die for good accuracy, linearity and stability, All Sensors chose to use two of the same sensor dies, route pressure to them in opposite directions, and measure the differential signal between the two.

Silicon die from the same wafer batch have very good correlation, so errors such as non-linearity, temperature dependence and offsets can be nulled from the output signal. Such an arrangement is

similar to making a Wheatstone bridge from two on-die bridge sensors. This patented method \ provides [active dual-die compensation](#) for common-mode pressure sensor errors.

To provide better performance, especially for low pressure measurements, the die structure in All Sensors' chip uses a proprietary Collinear Beam² or COBEAM^{2™} technology. COBEAM² technology is designed to provide better pressure sensitivity in a small package, which previously required boss structures and larger die topologies. The smaller die design without the boss structure significantly reduces both unwanted gravity and vibration sensitivity.

Summary & Conclusions

Years ago, a significant amount of knowledge was needed to implement a pressure measurement into the system, starting from sensor design, low-noise and a stable front end for the sensor, measurement system and compensation methods. Today, even students without any practical electronics design background can get digital output sensors, connect them to popular platform like a Linux-based Raspberry Pi or Arduino and get initial pressure measurements in a matter of hours, not weeks. The obtained value is already a calibrated and compensated value, ready to be used for further processing in an application.

Given the noise levels in the maximum practical application, pressure sensors with an 18-bit ADC provide equally acceptable results as a 24-bit ADC. In fact, 17-bit ENOB is only achievable with a low noise pressure sensor die, such as All Sensors CoBeam² Technology, which is superior to other low noise solutions. Furthermore, All Sensors DLH/R series pressure sensors are easy to use and require no external math by the user.

Signal conditioned silicon pressure sensors with a digital output have achieved pricing and packaging that make them acceptable for a wide number of applications. Their accuracy and digital compensation makes them attractive in variety of precision sensing projects including many industrial applications. These applications include flow metering, liquids level measurements, process monitoring, research, optical power detection and many more. With the new high resolution digital sensors, applications can now be addressed which were not possible before with the industry-standard 14-bit ADCs that provided a maximum 13-bit ENOB.

CoBeam² is a trademark of All Sensors Corporation. All other trademarks are the property of their respective owners.

Reference

1. Based on "Evaluation of modern pressure sensors with digital interface," <https://xdevs.com/article/pressure/>

All Sensors **Pressure Points** are application tips to simplify designing with microelectromechanical systems (MEMS) pressure sensors and avoiding common pitfalls.

Pressure Point 12: Making MEMS Pressure Sensors Easier to Use (Part 2)

Pressure is one of the most common measurements. Based on their small size, low cost and high reliability, microelectromechanical systems (MEMS) pressure sensors that use the high-volume manufacturing techniques of the semiconductor industry are found in over 90% of today's applications.

It could be said that there are two types of pressure measurements: those that are made using a MEMS pressure sensor and those that will be. In either case, pressure sensors that are easier to use help designers of products for new or existing applications get their products to market faster. Pressure sensors with a digital output and an evaluation board have two aspects that make design-ins easier. Providing comparative data on two popular MEMS pressure sensors, this two-part white paper will show how pressure sensors with sigma-delta ($\Delta\Sigma$) analog to digital converters (ADCs) (Part 1) and a sensor evaluation kit (Part 2) simplify design-ins.

Sensors with an Integral ADC

To simplify the use of an analog sensor in digital systems, some sensor manufacturers offer sensors with an integral ADC. A comparison of test results is shown later in this report. Table 1 shows the sensors from All Sensors Corporation (ASC) and another supplier and Table 2 shows their key specifications. This includes the effective number of bits (ENOB) resolution and the total error band (TEB), which typically provides the most important "accuracy" for many applications.

Sensor	TEB
All Sensors DLHR-L10D	±0.75%
All Sensors DLHR-L02D	±0.75%
All Sensors DLHR-L01D	±1.00%
Supplier X Product 1	±2.0%
Supplier X Product 2	±1.0%

Table 1. Pressure sensors with digital front-end selected for test

Parameter	DLHR-L10D	DLHR-L02D	DLHR-L01D	Product 1	Product 2
Pressure range	Diff., ± 10 inH ² O	Diff., ± 2 inH ² O	Diff., ± 1 inH ² O	Diff., ± 20 inH ² O	Diff., ± 2 inH ² O
Sensor die configuration	5-resistor bridge, 2×2mm proprietary die			4-resistor bridge, 2.5×2.5mm proprietary	
ADC Type	16/17/18-bit Δ - Σ			24-bit Δ - Σ	
DSP	YES			NO	
TEB	$\pm 0.75\%$	$\pm 0.75\%$	$\pm 1.00\%$	$\pm 1.0\%$	$\pm 2.0\%$
Output rate	15 to 270 SPS			20 SPS to 2000 SPS	
Typical ENOB min. speed	17 bits			18 bits	16 bits
	16 SPS			20 SPS	
INL				± 15 ppm of FSR (ADC)	
Power requirements	Single, 1.68 – 3.63 VDC			Single, 2.3 – 5.5 VDC	
Onboard temperature sensor	Yes, 16 bits			Yes, 14 bits	
Temperature range	-25°C to +85°C			-40°C to +85°C	
Digital interface	I ² C, SPI			SPI	
One off reference price (DigiKey/Mouser)	\$53.04 USD			\$57.61 USD	

Table 2. Specification comparison of evaluated pressure sensors

Disregarding the output data resolution, the accuracy (TEB) specifications differ significantly. This confirms earlier theory, that the accuracy of the pressure sensor is a system measurement, not depending on ADC resolution.

The All Sensors Difference

Since it is not easy to compensate silicon die for good accuracy, linearity and stability, All Sensors chose to use two of the same sensor dies, route pressure to them in opposite directions, and measure the differential signal between the two.

Silicon die from the same wafer batch have very good correlation, so errors such as non-linearity, temperature dependence and offsets can be nulled from the output signal. Such an arrangement is similar to making a Wheatstone bridge from two on-die bridge sensors. This patented method \ provides [active dual-die compensation](#) for common-mode pressure sensor errors.

To provide better performance, especially for low pressure measurements, the die structure in All Sensors' chip uses a proprietary Collinear Beam² or COBEAM^{2™} technology. COBEAM² technology is designed to provide better pressure sensitivity in a small package, which previously required boss structures and larger die topologies. The smaller die design without the boss structure significantly reduces both unwanted gravity and vibration sensitivity.

All Sensors Eval Board Review

In addition to simplifying the use of a pressure sensor in a digital system by providing an integral ADC, All Sensors offers its [All Sensors evaluation kit](#) to test pressure sensors before the prototype design process. This evaluation kit (see Figure 1) is capable of providing data on digital, millivolt, and amplified pressure sensors and has the following features:

- Has a ZIF socket that allows instant electrical connection, without need of soldering or pin forming.
- Displays data from digital sensors in one of 12 convenient units
- Captures data from digital sensors to comma-separated values (CSV) text file, with sample index and timestamp on each readout
- Uses standard Windows USB HID drivers. Eval board using micro-USB connector for data/power.
- Has standard 4-mm banana-type terminals for lab test equipment and external power

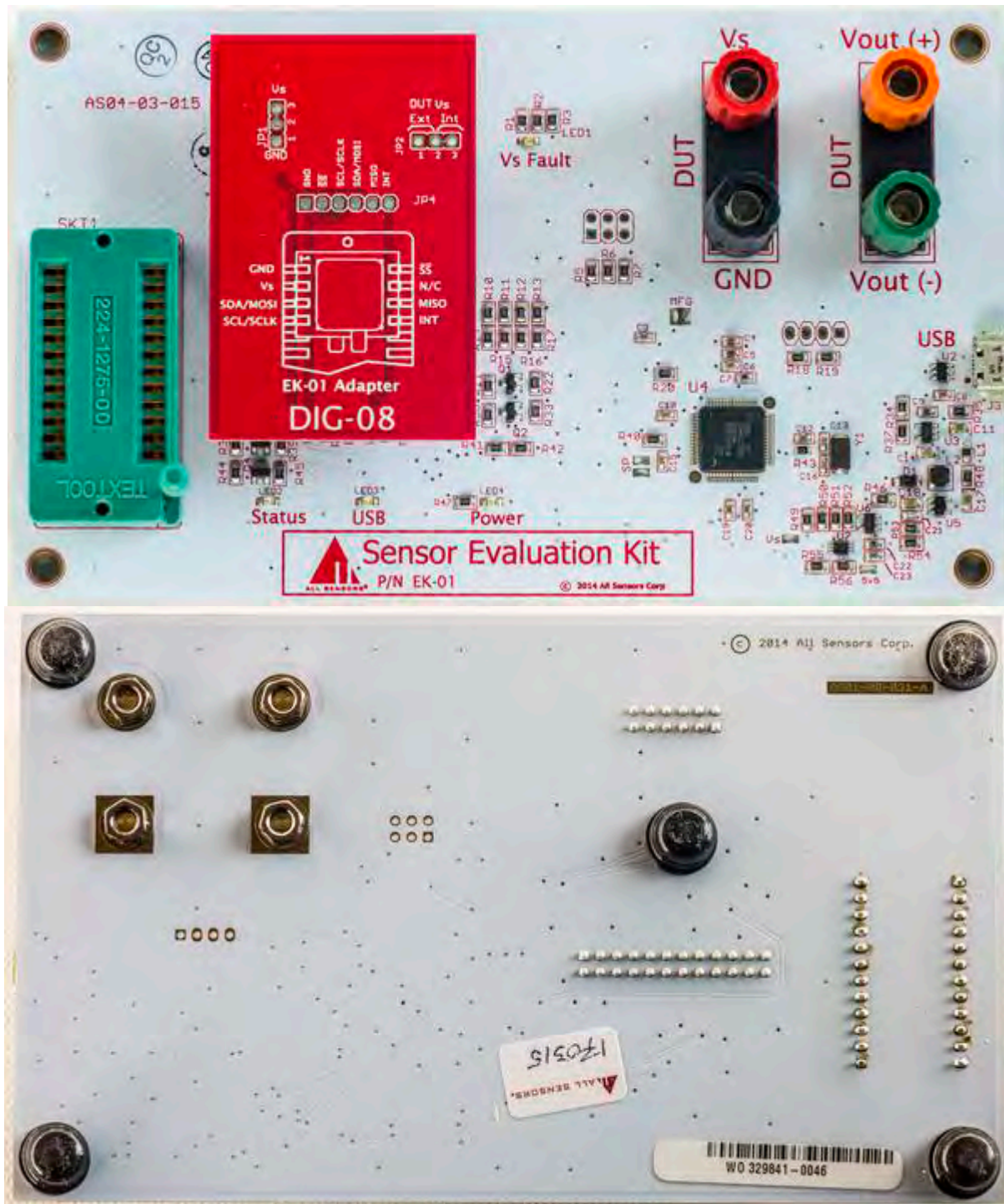

Figure 1. Evaluation board for All Sensors devices

The Evalkit is based around [Texas Instruments TM4C1233D5PM](#) Cortex-M4F ARM® microcontroller. It has a native USB 2.0 interface, as well as I²C and SPI interfaces to communicate with sensors and is specified to operate in the industrial range.

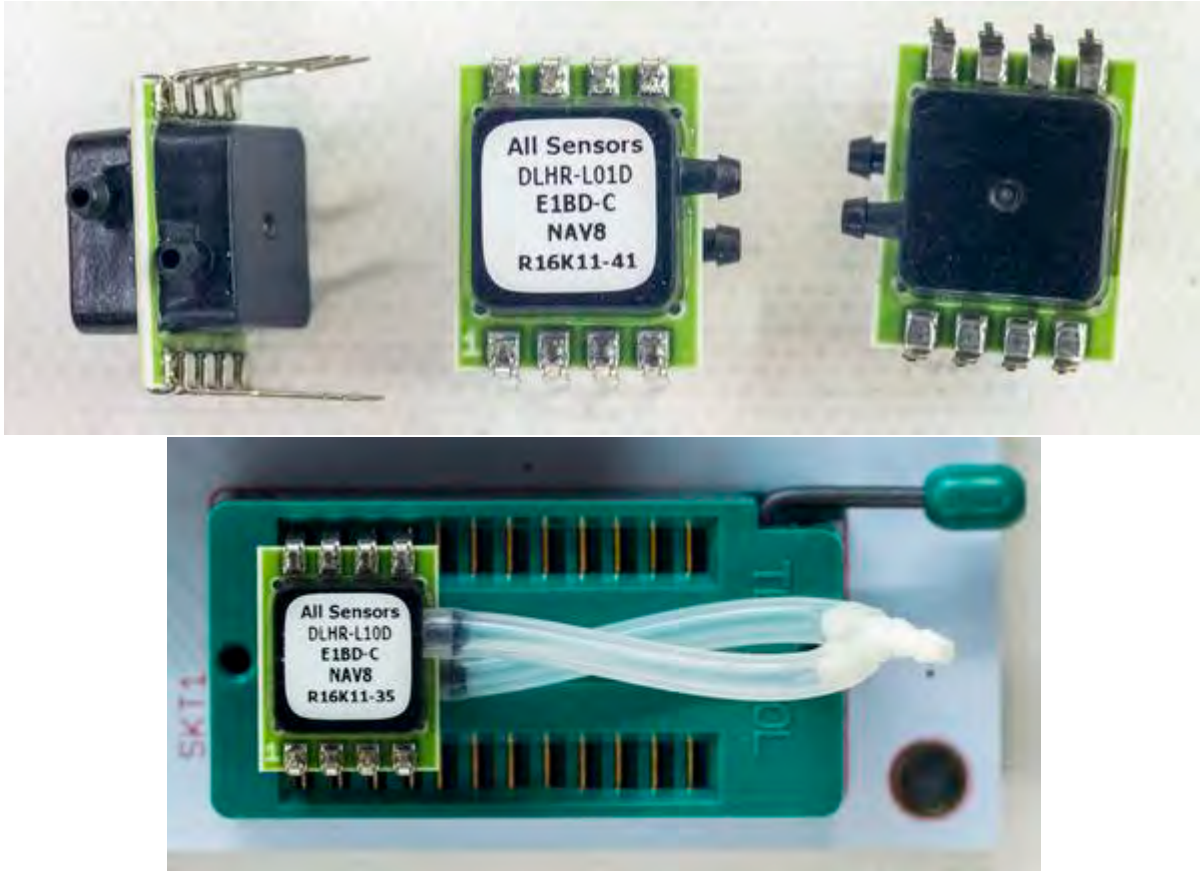

Figure 2. Sensor and connection to Evalboard socket

The evaluation kit comes with a simple to use software tool. It supports various sensors with both SPI and I²C interface connections, and can be used to set data timings, pressure measurement units and average filtering power. See Figure 3. Once a sensor is properly configured, the software reads both pressure and temperature and displays the results on a graphic user interface (GUI). Data stored into a CSV file can be used for longer data captures and external data analysis.

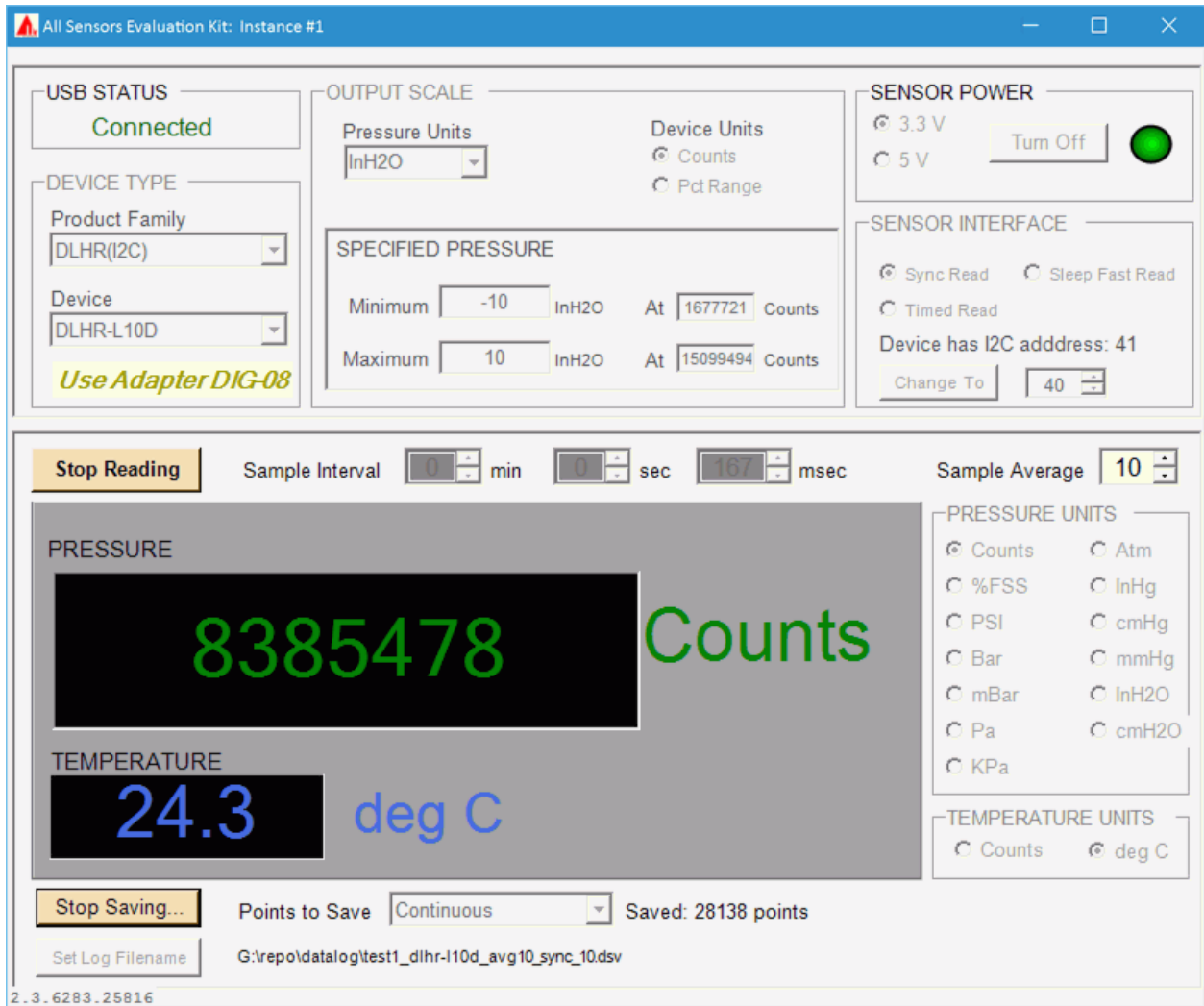

Figure 3. Demo kit software GUI

Comparative Test Results

In this testing, a Fluke 719 calibrator provides a known pressure into the sensors and their output digital values are recorded at the same time to compare calibration results. The second port of both sensors is open to atmosphere, converting the differential sensor into a simplified gauge device.

Reference input	Used sensors	Fluke 719 reading	ASC sensor	X sensor
-1.00 inH2O	DLHR-L01D + X	-1.00 inH2O	-1.008 (0.8%)	-0.938 (-6.2%)
-0.50 inH2O	DLHR-L01D + X	-0.50 inH2O	-0.4994 (-0.12%)	-0.474 (-5.2%)
-0.25 inH2O	DLHR-L01D + X	-0.25 inH2O	-0.2496 (-0.16%)	-0.242 (-3.2%)
0.00 inH2O	DLHR-L01D + X	0.00 inH2O	0.004	0.002
+0.25 inH2O	DLHR-L01D + X	+0.25 inH2O	0.2561 (2.44%)	0.247 (-1.2%)
+0.50 inH2O	DLHR-L01D + X	+0.50 inH2O	0.5077 (1.54%)	0.468 (-6.4%)
+1.00 inH2O	DLHR-L01D + X	+1.00 inH2O	1.009 (0.9%)	0.927 (-7.3%)

Table 3. DHLR-L01D and Supplier X Comparison results with Fluke 719 30G calibrator output

Large offset was read from the Supplier X sensor. Additional calibration and compensation math may be required to provide better calibration results, so these results obviously need further investigation. Repeated tests show the same numbers, so the data is provided here as is. Note: the Fluke 719 30G is not the best tool to source pressure levels below 5 inH2O.

Reference input	Used sensors	Fluke 719 reading	ASC sensor	X sensor
-2.00 inH2O	DLHR-L02D + X	-2.00 inH2O	-1.996 (-0.2%)	-1.869 (-6.5%)
-1.00 inH2O	DLHR-L02D + X	-1.00 inH2O	-1.001 (0.1%)	-0.932 (-6.8%)
-0.50 inH2O	DLHR-L02D + X	-0.50 inH2O	-0.507 (1.4%)	-0.467 (-6.6%)
0.00 inH2O	DLHR-L02D + X	0.00 inH2O	0.001	0.008
+0.50 inH2O	DLHR-L02D + X	+0.50 inH2O	0.503 (0.6%)	0.465 (-7%)
+1.00 inH2O	DLHR-L02D + X	+1.00 inH2O	1.006 (0.6%)	0.927 (-7.3%)
+2.00 inH2O	DLHR-L02D + X	+2.00 inH2O	2.005 (0.25%)	1.861 (-6.95%)

Table 4. DHLR-L02D and Supplier X comparison results with Fluke 719 30G calibrator output

Similar offset around 7% was detected from the Supplier X sensor as well. Code to interface sensor was reused, with correction for different pressure range. ASC sensor data was below 1.5%.

Reference input	Used sensors	Fluke 719 reading	ASC sensor	X sensor
-20.00 inH2O	DLHR-L10D + X	-20.00 inH2O	N/A	-18.979 (-5.1%)
-15.00 inH2O	DLHR-L10D + X	-15.00 inH2O	N/A	-14.226 (-5.1%)
-12.00 inH2O	DLHR-L10D + X	-12.00 inH2O	-12.005 (0.04%)	-11.400 (-5%)
-10.00 inH2O	DLHR-L10D + X	-10.00 inH2O	-10.012 (-0.12%)	-9.531 (-4.69%)
-8.00 inH2O	DLHR-L10D + X	-8.00 inH2O	-8.017 (0.21%)	-7.614 (-4.82%)
-6.00 inH2O	DLHR-L10D + X	-6.00 inH2O	-6.018 (0.3%)	-5.688 (-5.2%)
-4.00 inH2O	DLHR-L10D + X	-4.00 inH2O	-4.004 (0.1%)	-3.793 (-5.17%)
-2.00 inH2O	DLHR-L10D + X	-2.00 inH2O	-2.015 (0.75%)	-1.902 (-4.9%)
-1.00 inH2O	DLHR-L10D + X	-1.00 inH2O	-1.007 (0.7%)	-0.944 (-5.6%)
0.00 inH2O	DLHR-L10D + X	0.00 inH2O	-0.02	-0.008 ()
+1.00 inH2O	DLHR-L10D + X	+1.00 inH2O	1.010 (1%)	0.958 (-4.2%)
+2.00 inH2O	DLHR-L10D + X	+2.00 inH2O	2.002 (0.1%)	1.904 (-4.8%)
+4.00 inH2O	DLHR-L10D + X	+4.00 inH2O	3.997 (-0.075%)	3.805 (-4.9%)
+6.00 inH2O	DLHR-L10D + X	+6.00 inH2O	6.003 (0.05%)	5.705 (-4.9%)
+8.00 inH2O	DLHR-L10D + X	+8.00 inH2O	7.997 (-0.037%)	7.586 (-5.2%)
+10.00 inH2O	DLHR-L10D + X	+10.00 inH2O	9.998 (-0.02%)	9.483 (-5.17%)
+12.00 inH2O	DLHR-L10D + X	+12.00 inH2O	11.965 (-0.29%)	11.381 (-5.15%)
+15.00 inH2O	DLHR-L10D + X	+15.00 inH2O	N/A	14.221 (-5.2%)
+20.00 inH2O	DLHR-L10D + X	+20.00 inH2O	N/A	18.964 (-5.18%)

Table 5. DHLR-L10D and Supplier X comparison results with Fluke 719 30G calibrator output

Here, the apparent error of Supplier X's output was visible and very high, requiring addition correction for 5% offset. This is a good example that higher resolution on its own does not guarantee better accuracy of the system.

Given the unknown calibration or use history of Fluke 719 used in this test, the obtained results are good, mostly well under 1% for All Sensors DLHR sensors. Thanks to its onboard DSP, which handled all calibration and internal data correction, using the DLHR-LxxD sensors was very easy and straightforward.

The other supplier's pressure sensor however had extra offset, which need to be manually corrected. Compensation for Supplier X's sensors was performed according to datasheet listed math and stored EEPROM data.

Summary & Conclusions

Years ago, a significant amount of knowledge was needed to implement a pressure measurement into the system, starting from sensor design, low-noise and a stable front end for the sensor, measurement system and compensation methods. Today, even students without any practical electronics design background can get digital output sensors, connect them to popular platform like a Linux-based Raspberry Pi or Arduino and get initial pressure measurements in a matter of hours, not weeks. The obtained value is already a calibrated and compensated value, ready to be used for further processing in an application.

Given the noise levels in the maximum practical application, pressure sensors with an 18-bit ADC provide equally acceptable results as a 24-bit ADC. In fact, 17-bit ENOB is only achievable with a low noise pressure sensor die, such as All Sensors CoBeam² Technology, which is superior to other low noise solutions. Furthermore, All Sensors DLH/R series pressure sensors are easy to use and require no external math by the user.

Signal conditioned silicon pressure sensors with a digital output have achieved pricing and packaging that make them acceptable for a wide number of applications. Their accuracy and digital compensation makes them attractive in variety of precision sensing projects including many industrial applications. These applications include flow metering, liquids level measurements, process monitoring, research, optical power detection and many more. With the new high resolution digital sensors, applications can now be addressed which were not possible before with the industry-standard 14-bit ADCs that provided a maximum 13-bit ENOB.

CoBeam² is a trademark of All Sensors Corporation. All other trademarks are the property of their respective owners.

Reference

1. Based on "Evaluation of modern pressure sensors with digital interface," <https://xdevs.com/article/pressure/>

ALL SENSORS®

How to minimize warm-up drift in pressure sensors

Tim Shotter
Director New Products
All Sensors Corp.
Morgan Hill, Calif.
allsensors.com

Edited by Leslie Gordon, *Medical Design*

Warm-up drift in pressure sensors makes their readings vary until systems reach operating temperature. It's usually of little concern. However, such drift is unacceptable in hospital respirators, spirometry equipment, neonatal monitors, and similar devices requiring high accuracy at all times. Examining a basic piezoresistive pressure sensor helps to understand the effect of warm-up drift.

The sensor is made of a body, or "die," and a thin silicon diaphragm with four piezoresistors on the surface. The piezoresistors change resistance in response to stress. They are generally arranged in a bridge configuration and are precisely located on the diaphragm surface to maximize the response to diaphragm deflection. This in turn maximizes the response to a pressure differential across the diaphragm.

Warm-up shift

There are two primary sources of warm-up drift in a basic pressure sensor. One is the warm-up shift of the sensing element. While the system is reaching operating tempera-

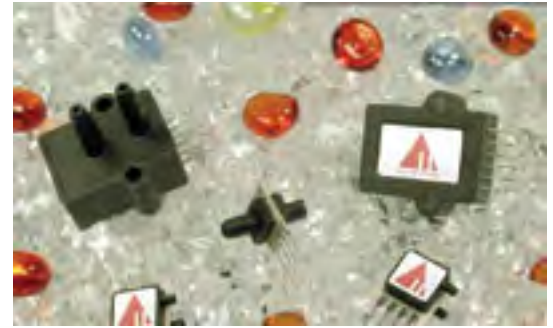

An assortment of sensors features the 0.025-in. H20 Full Scale A-package (top) and a range of mini packages. The A-package accurately reads exceedingly low pressures. The devices are for drug delivery, respiratory, and similar applications where physical size is not a constraint. Mini packages target devices requiring a smaller sensor such as for measuring oxygen in a medical device.

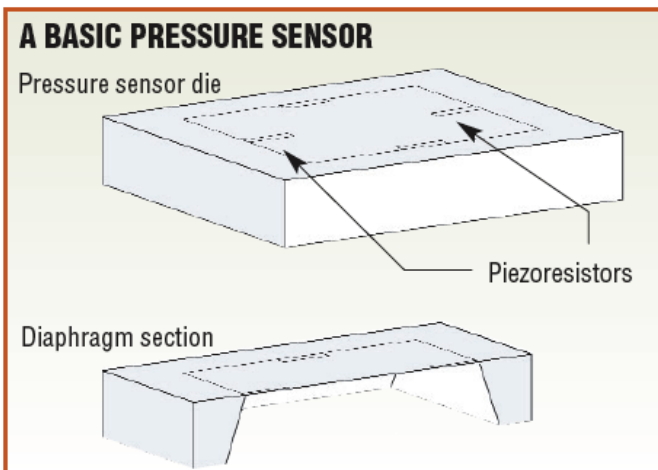

A basic pressure sensor is made of a die and a diaphragm with four piezoresistors on the surface.

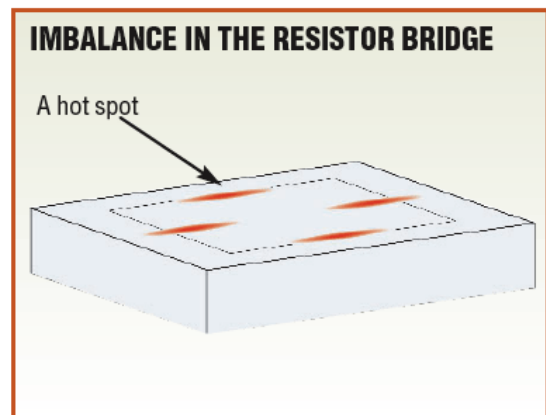

Thermal hot spots on the die and diaphragm surface (orange lines) cause an imbalance in the resistor bridge.

ture, surface temperature and resultant thermal hot spots (surface contribution) on the die and diaphragm surface cause an imbalance in the resistor bridge. The temperature rise of the resistor-sensing element is proportional to the dissipated power and therefore proportional to the square of the excitation voltage of the sensor ($\Delta T \propto V^2$).

Thus, reducing the excitation voltage by a factor of two reduces the sensing element temperature rise by a factor of four and, consequently, the warm-up surface condition is reduced by a factor of four. Since the signal level of the sensor is also reduced by a factor

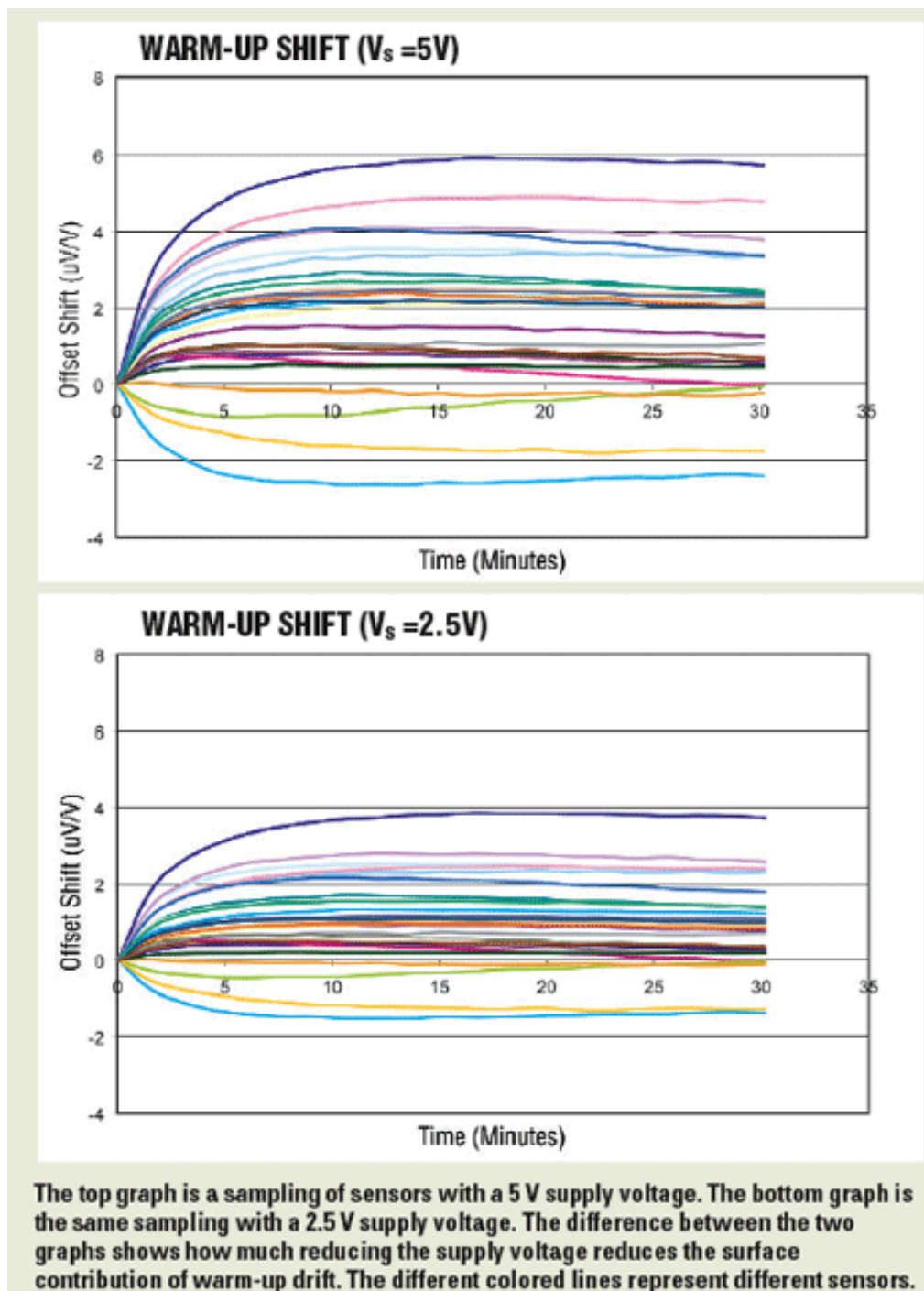

of two (with the reduced supply voltage), the overall effect is a reduction in surface contribution warm-up error by a factor of two. However, reducing the sensor power supply adversely affects the system electronic noise level.

An alternate and preferred approach to reducing supply voltage modulates the sensor supply as required by the system bandwidth. In other words, apply power to the sensor only when needed. This reduces power to the sensor to the time average (duty-cycle) applied and, hence, reduces warm-up drift. The method is slightly more sophisticated but can provide excellent results and without affecting system noise level.

Here the period, p , between power pulses for an application is the time the power is off plus the time the power is on. This is the time required to have all signals stabilize and the sensor to take a reading.

For example, consider a device that requires readings every 500 ms, has a settling time of 4 ms, and has a signal-acquisition time of 1 ms. The average power to the sensor is only about 1% ($[1 \text{ ms} + 4 \text{ ms}]/500 \text{ ms}$) of the power applied as compared to a non-modulated system.

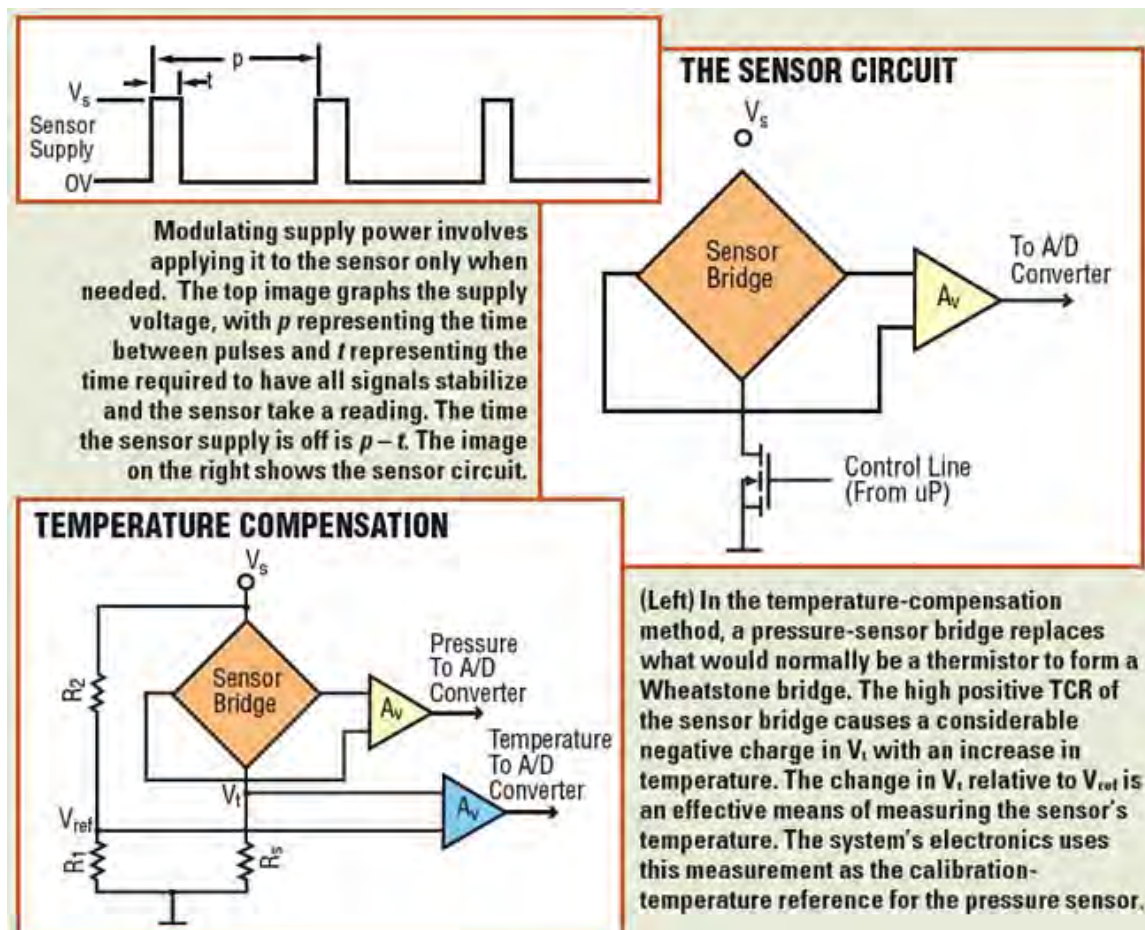

Of course, the period depends on an application's sampling requirements. It's important that p and on time t remain constant because of subtle surface charges. However, this is a minor constraint considering the benefits of modulating the sensor supply.

Temperature-compensation technique

Another source of warm-up drift is actually more a perceived characteristic and is related to the system's temperature-compensation technique. Systems often have an external temperature sensor for use in calibrating the pressure sensor for the effects of temperature. Such dual-sensor systems have a temperature gradient between the external device and the surface temperature of the diaphragm. The time it takes for a temperature gradient to stabilize is perceived as warm-up drift.

Minimizing this effect is accomplished by using the sensor resistance (bridge resistance-change with temperature) as the temperature-sensing element. Here the pressure-sensor bridge replaces what would normally be a thermistor (a type of resistor used to measure temperature changes) in a circuit that effectively becomes a Wheatstone bridge.

The sensor bridge has a high positive temperature coefficient of resistance (TCR) so an increase in temperature causes an increasingly negative charge in the signal output voltage (V_t) of the temperature-monitoring portion of the circuit. The change in V_t relative to the reference voltage (V_{ref}) is an effective measurement of the sensor temperature itself. The system electronics uses this measurement as the calibration-temperature reference for the pressure sensor. This eliminates the perceived warm-up drift because an external temperature sensor is not involved, so there is no thermal gradient. The good news is that modulating supply and temperature-compensation methods can be used together to almost eliminate the effect of warm-up drift.

Design Considerations for Pressure Sensing Integration

Where required, a growing number of OEM's are opting to incorporate MEMS-based pressure sensing components into portable device and equipment designs, as a means of ensuring reliability, safety and quality. The choice of pressure sensing type within these applications tends to be highly specific to the intended operating characteristics of both the sensor and device itself.

A handheld battery operated spirometry device, for example, must be able to be turned on and off quickly and instantly, while continuously recording data over a 20-second period with optimized use of available power, thus requiring a low-voltage [pressure sensor](#) which is able to use power only as needed. In another instance, pressure sensors for handheld HVAC monitors, due to their portability and manner of use, cannot be overly susceptible to vibration or position changes, which could ultimately affect measurement integrity.

Among the various types of sensing technologies, low-voltage die-based MEMS pressure sensors, such as those manufactured by All Sensors Corporation, offer some of the greatest advantages within [portable devices](#), including high-reliability performance and extended useful service life. This is particularly important for environments characterized by a wide dynamic [temperature](#) range, or where external shock and vibration is present. Low-voltage MEMS pressure sensor components are comparatively lower in cost and offer high-quality mass customization and production capabilities. When integrated into assembled portable devices and equipment, they can help achieve exceptional measurement linearity and repeatability, with minimized power consumption and extended service life. All of these factors influence sensor selection for portable OEM devices.



Because of their unique advantages, OEM's are driving new market introduction of MEMS pressure sensing technologies that can be reliably used across a multitude of application environments; which offer ability to apply lower supply voltages to obtain a higher output signal with measurement stability; and which allow for low warm-up shift and low position sensitivity. In addition, these sensors can be isolated from internal device electronics, offering added protection from signal degradation as a result of [thermal](#) transfer.

When selecting an appropriate pressure sensor for integration into a portable device, it is important to understand a sensor's own unique performance characteristics as they relate to device operation requirements, as well as the unique operating conditions of the intended device usage environment and collective potential effects on device performance. The following is an overview of these considerations, along with a few application examples of the successful integration of All Sensors low-voltage MEMS pressure sensors into finished portable device and equipment designs.

Sensor Die Design

A typical MEMS pressure sensor is constructed of a body, or “die,” and a thin silicon diaphragm with four surface piezoresistors, whose resistance changes in response to mechanical stress. They are generally arranged in a bridge configuration and are precisely located on the diaphragm surface to maximize deflection response. In doing so, pressure differential response is maximized across the diaphragm. MEMS pressure sensor quality and performance within an application environment is most directly tied to sensor die quality. As a result, MEMS pressure sensing manufacturers strive to produce the smallest and highest quality die possible for desired customer sensitivity levels, overall performance stability, and therefore, facilitating highly compact packaging requirements.



Package Size

By definition, a portable device is characterized by its ability to be easily transportable and with on-demand functionality. This typically calls for compact pressure sensor designs which offer performance stability, low voltage requirements, and which can reliably operate in a lightweight, easily transported package. Thus, when incorporating pressure sensing technologies into portable device designs, compactness is a near-absolute requirement. The space constraints within the devices themselves impose certain limitations on sensing technology options within these types of applications. Sensors must not only operate within a small package, they must also be isolated from the internal device electronics to avoid signal degradation.

While traditional low-pressure ceramics products are still in use to satisfy these requirements within some smaller device applications, they are design prohibitive for portable devices, as size and weight remain major considerations. Equally important is for the sensor to be compact enough that it will not cause stress on the sensor package within the assembled device, as this affects overall output signal accuracy, ultimately effecting overall device performance. Recognizing the importance of these considerations, All Sensors has recently introduced its new BLV/BLVR and MLV series. The sensors are manufactured from the industry’s smallest single pressure die for its sensitivity levels, and therefore allows for compact packaging, facilitating easy integration into portable device designs with reduced risk of package stress. Custom packaging requirements are also a core specialty for All Sensors, which routinely works with OEMs on the successful integration of pressure sensors into more challenging environments.

Temperature Variation

Operating temperature variations can also have a direct effect on MEMS pressure sensor offset voltage and output span, and can ultimately affect overall measurement stability. Portable device applications typically require use of a pressure sensor that can reliably operate in moderate temperature excursions of 0 to +50°C, though certain operating conditions can require more

extensive ranges. Portable oxygen concentrators are an example of a device featuring integrated pressure sensors that are used in relatively moderate temperatures, though some models may require a sensor with wider, industrial-level temperature ranges of -20 to +85°C. To meet these varying range requirements, manufacturers frequently look for a pressure sensing technology with either user-adjustable or integral temperature compensation options.

MEMS-based pressure sensing component technologies, such as the All Sensors BLV and BLVR Basic Pressure Sensor Series, are commonly offered with customer-applied temperature compensation capability, which allows manufacturers to tailor temperature performance to their own device performance requirements. Alternately, the All Sensors MLV series offers integral temperature compensation of offset and span, via a laser trimmed film compensation network, to satisfy this application consideration.

Sensor Output and Device Stability

Sensor output sensitivity is another parameter that will impact signal strength at a particular operating voltage. Higher sensitivity devices can typically be operated at lower voltages with less signal degradation. The higher output level of the pressure sensing die used offsets the lower operating voltage, thus maintaining comparable signal-to-noise ratios to those found in previous generation devices.

Power/Voltage Supply Requirements and Warm-up Shift

As most portable devices are battery operated, pressure sensor power and voltage supply requirements have traditionally been 5V, though the general trend has been a move toward 3.3V or lower voltages, to help further preserve product battery life. These lower power requirements facilitate easier customer integration of sensors into finished product designs, with increased measurement stability and performance. This is because the risk of internal self-heating and related offset shifts are reduced.

Warm-up Shift Test Results

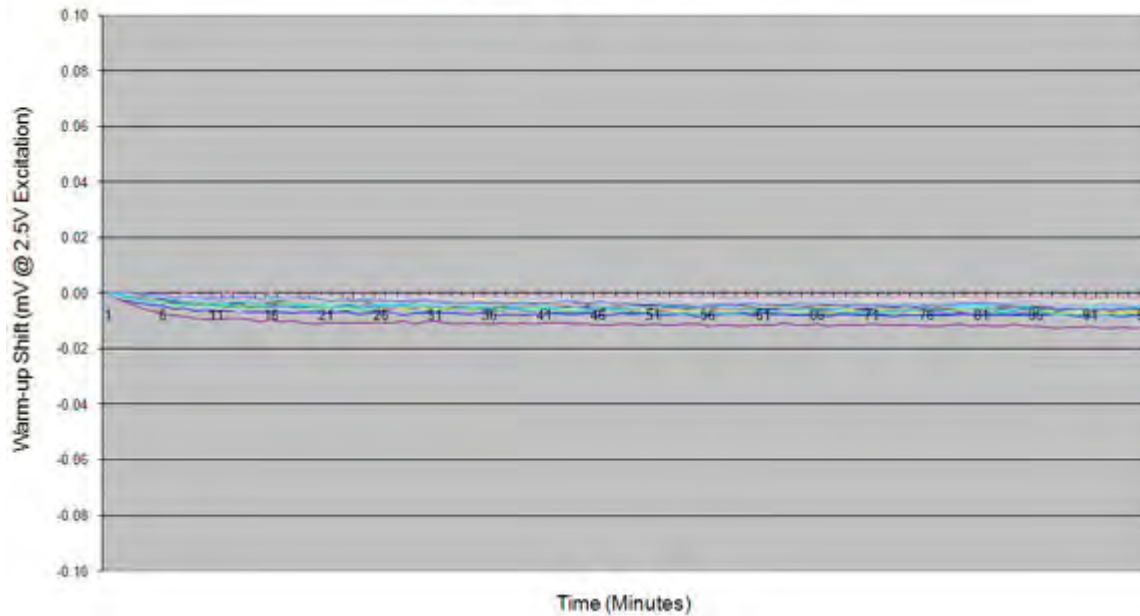

When considering temperature requirements, warm-up shift is also a concern. The warm-up shift of a device is, simply, the effect that power has on device physical characteristics in its warm-up phase. An alternate and preferred approach to reducing supply voltage modulates the sensor supply as required by the system bandwidth. In other words, apply power to the sensor only when needed. This reduces power to the sensor to the time average (duty-cycle) applied and, hence, reduces warm-up drift. The method is slightly more sophisticated but can provide excellent results and without affecting system noise level.

To help manage power requirements, pressure sensors are offered in both compensated and uncompensated versions. Compensated devices offer lower calibration costs, faster production cycles, lower production equipment overhead, and easier design-in capabilities. Uncompensated versions are generally designed to operate a 5V.

Low voltage pressure sensors offer 1.8 and 3.3 V power supply requirements, to facilitate sensor integration into portable device and equipment designs. The All Sensors BLV Series Basic Sensor is designed to provide a high output signal at a low operating voltage of 1.8V, reducing the overall supply voltage while maintaining comparable output levels to traditional equivalent basic sensing elements. The series uses 10% of the power of standard parts, while the BLVR Series offers 40% of power requirements. These lower supply voltages give rise to improved warm-up shift, resulting in improved overall long-term stability. In addition, these sensors offer lower cost and a 90% reduction in position sensitivity as compared to similar type devices. The BLV Series is intended for use with non-corrosive, non-ionic working fluids such as air, dry gases and the like. The output is also ratiometric to the supply voltage and is operable from 0.9 to 1.8 volts DC. The benefit of manufacturers of this technology is improved device efficiencies and performance, as well as longer useful device life.

Cost Savings

Within a finished portable device, the requirement for cost savings in pressure sensor selection is especially important, as both sensors and devices are mass produced for wide commercial availability. The intended price point of the finished device can put certain limitations on the type of pressure sensing technology specified. The BLV series, because of its low power supply requirements and single die configuration, as well as improved warm-up shift and position sensitivity, offers design flexibility and cost savings with greater value for investment, as well as the ability to be used within applications that formerly would require dual pressure sensing die configurations. This allows power requirement reductions, and ultimately, allows OEM's to offer product performance improvements at roughly the same price point.

Some examples of the successful incorporation of low-voltage MEMS pressure sensors may be found in the following applications:

HVAC Pressure Transmitter for Building Monitoring

A portable industrial airflow measurement device is used for on-demand measurements of low airflow beneath HVAC vents within typical office environments or apartment building setups. Typically, this application requires use of a basic pressure sensor with unconditioned, uncompensated millivolt output signal, and simply provides a raw output signal for the OEM device. Within the intended pressure sensor usage environment, the selected component must offer long-term reliability and stability, as well as relatively good accuracy and low environmental media sensitivity. The device application environment itself is typically characterized by modest temperature variations and humidity. In these types of applications, the requirement for low warm-up shift is also important, as the device needs to operate with stability soon after powered on. Position sensitivity is less important, as the device itself is specifically orientated under duct work. The signal-to-noise ratio (or noise floor) of these sensors must be very low, as very small air pressures are being measured. Low power consumption, due to battery or current loop operation, is also a significant consideration.

Within this application environment, precision low-pressure measurements are required, along with a customer capability to perform any needed pressure sensor temperature compensation. Based on the unique requirements of both device and integrated sensor, the All Sensors BLVR Series Basic Pressure Sensor is recommended, as both offset errors due to temperature shift and warm-up shift are minimal. These sensors are designed to reliably operate in temperature ranges from -25 to +85°C, with 0 to 95% relative humidity ranges (non-condensing).

Medical Breathing Apparatus

An example of an application requiring a higher degree of accuracy and performance can be found in medical breathing apparatus used within critical patient care applications. Device designs must be highly rugged, as well as offer high accuracy and reliability within demanding environments. As medical breathing devices are employed within hospital, urgent care and other clinical settings, they can be subjected to ongoing high levels of shock, vibration and g-force pressures, as well as wide output ranges. The demands placed upon devices within their intended usage environment would require OEM's to specify a millivolt output or amplified pressure sensor, fully calibrated and temperature compensated. Low position and shock sensitivity are also requirements.

Also required for this type of device is the integral amplification of the pressure sensor. The amplified pressure sensor component typically houses an onboard ASIC (built-in amplifier with compensation), allowing control of the millivolt output sensor gain, noise and compensation. Amplified devices are scaled to fall into the input range of a common analog-to-[digital](#) microprocessor without additional gain. The amplified pressure sensor can be thought of as an accurate, compensated device with an amplified output signal that is more plug-and-play for the OEM. This is typically required when the customer's analog-to-digital converter does not have a built-in gain feature.

This type of application typically uses a compensated millivolt pressure sensor. Compensated millivolt low-voltage pressure sensors are calibrated to both zero and span and are temperature compensated, to ensure accurate output signal over a specified operating temperature range. A compensated device is typically used in an application where accuracy is a priority and the OEM relies on the pressure sensor manufacturer to provide all temperature compensation and calibration within the pressure sensor itself. In this case, a manufacturer typically requires a clean, low-noise output signal. The OEM would typically provide an amplifier or ASIC somewhere on their PCB to increase the mV output signal.

To meet the demands of both sensor operating performance and overall device performance criteria, All Sensors offers the MLV Series low-voltage compensated pressure sensor. This series offers OEM's a device with the added flexibility of extended temperature compensation ranges for use in extreme environments, and less external effort by the OEM to successfully incorporate the sensing technology into product prototype designs. The MLV Series Compensated Sensor is based on All Sensors' CoBeam2™ Technology. The device provides a high output signal at a low operating voltage, while maintaining comparable output levels to traditional equivalent compensated millivolt sensors operating at higher voltages. This lower supply voltage gives rise to improved warm-up shift while the CoBeam2 Technology itself reduces package stress susceptibility, resulting in improved overall long-term stability. The technology also vastly improves position sensitivity, as compared to conventional single die devices.

These are just a few examples of the active use of All Sensors low voltage MEMS-based pressure sensing technologies within these types of applications. In addition to those referenced here, successful applications have also included avionics, environmental monitoring equipment, portable oxygen therapy machinery and remote sensing applications. For more information, visit www.allsensors.com.

Additional Resources

Definition of Terms

Absolute Pressure: Pressure measured relative to a vacuum. Usually expressed in pounds per square inch absolute (psia).

Altimetric Pressure Transducer: A barometric pressure transducer used to determine altitude from the pressure altitude profile.

Auto-Referencing: A technique for eliminating errors by sampling one or more reference pressures, then correcting the output signal function.

Barometric Pressure Transducer: An absolute pressure transducer measuring the local ambient pressure.

Best Straight Line (BSL): The best straight line chosen such that the true transducer response curve contains three points of equal maximum deviation.

Burst Pressure: The maximum pressure that may be applied to the sensor without causing the sensor catastrophic failure.

Common-Mode Error: An error that is independent of the major input variable (input pressure). For All Sensors transducers, all offset errors are common-mode errors.

Common Mode Pressure: The maximum pressure that may be applied to both sides of the diaphragm simultaneously with causing changes in performance to the specifications. Patent US 6,023,978 (Dauenhauer et al.): some of the products manufactured by All Sensors Corporation are licensed for use of the Honeywell US patent.6.023.978. This patent describes a technique for compensating piezo resistive pressure sensors using dual die compensation with electrical cross coupling and pneumatic cross coupling.

Differential Pressure: The pressure difference measured between two pressure sources. Usually expressed in pounds per square inch differential (psid). When one source is a perfect vacuum, the pressure difference is called absolute pressure. When one source is the local ambient, the pressure is called gage pressure.

Differential Pressure Transducer: A device that measures the differential pressure between two pressure sources piped to its inputs.

Error Band: The deviation of transducer response from its BSL, defined by lines on either side of its BSL and including the maximum deviation measured for a given normal mode or common mode error.

Full-Scale: The algebraic difference between endpoints. Where one endpoint is actual offset voltage and the other endpoint is the upper limit of the range.

Full Scale Shift: The shift in sensor output voltage sensitivity to pressure over the temperature range specified. This is equivalent to temperature coefficient of sensitivity. The characteristic of this transfer curve is very close to a second order equation for the basic piezo resistive sensing element. For the millivolt output devices, this is compensated with passive resistors; and for amplified output device, it is ASIC compensated with a second order curve fit to the data taken for each part over the pressure and temperature ranges specified. The characteristic of this transfer curve does not change with any other conditions.

Gage Pressure: Pressure measured relative to ambient pressure (psig).

Hysteresis of Pressure: Pressure hysteresis is measured as the maximum difference between the output at reference conditions before and after a pressure cycle.

Interchangeability: The error band defined by the maximum signal deviation obtained when a transducer is replaced by any other transducer of the same type with equivalent pressure inputs and temperature ranges.

Linearity: The maximum deviation of measured output at constant temperature (25°C) from "best straight line" determined by three points (offset pressure, full-scale pressure, and one-half full-scale pressure) where Y= measured value for each device

Linearity, Hysteresis Error: The error in the output voltage response to pressure over the full operating pressure range relative to the ideal output voltage response; the deviation from a first order transfer curve response of output signal to pressure. This error is a function of pressure and not a function of temperature. This error is computed by measuring pressure at three pressure points; zero pressure. Full scale pressure and one half full scale pressure and computed on the basis of a "best straight line" curve fit to the measured data.

Minimum/Maximum: Are the guaranteed limits for the specification. These limits are generally one hundred percent tested with a guard band between the test limits and the specification limits.

Most Probable Error: The error band obtained by computing the square root of the sum of the squares of all applicable errors specified for the transducer.

Nominal: It is the average value for a specification from product manufactured during the first production run.

Normal Mode Error: An error that is a function of (and usually assumed to be proportional to) the major input variable (input pressure). For All Sensors transducers, all span errors are normal mode errors.

Offset Calibration: The error band defined by the maximum error in calibrating the offset voltage.

Offset Error: The common-mode error band defined by the maximum deviation of offset voltage from its specified value. It may include calibration, temperature, repeatability and stability errors.

Offset Long Term Drift: The change in offset voltage that may occur over the time specified. Possible causes to this characteristic for piezo resistive pressure sensors have been studied for decades. There is, to date, no conclusive single cause or main causes to the error. Because most of All Sensors low pressure sensors use dual die electrical cross coupling compensation, there is inherent offset long term drift compensation. Products All Sensors tests for warm-up shift will generally identify any offset long term drift problems and would be rejected.

Offset Position Sensitivity: The change in offset voltage due to a change in position of the sensor. Sensors for measuring pressure exceeding 15 psi have virtually no position sensitivity. Because the diaphragm of the sensor has mass, and because the mass to diaphragm thickness ratio increases as the pressure range decreases, the sensitivity to position increases as the pressure range decreases. Because most of All Sensors low pressure sensors use dual die electrical cross coupling compensation there is inherent offset position sensitivity compensation in even the most basic sensors.

Offset Repeatability: The error band expressing the ability of the transducer to reproduce the offset voltage, measured at 25°C, after exposure to any other temperature and pressure within the specified range.

Offset Stability: The error band expressing the ability of the transducer to maintain the offset voltage with constant pressure and temperature.

Offset Temperature Coefficient: The error band defined by the maximum deviation in offset voltage as the temperature is varied from 25°C to any other temperature within the specified range.

Offset Temperature Shift: The change in output offset voltage over the specified temperature range. For non amplified sensors the specification limits are tested at three temperature points; 25°C, temperature maximum, temperature minimum, and back to 25°C. For amplified pressure sensors there are many more data points measured and the compensation is mathematically fit to the data points. There is generally no consistent equation to describe the offset temperature shift characteristic. Because most of All Sensors low pressure sensors use dual die electrical cross coupling compensation there is inherent offset temperature shift compensation in even the most basic sensor.

Offset Voltage: The output voltage when the sensor has zero differential pressure across the diaphragm. For absolute pressure sensors there is zero differential pressure across the diaphragm when the sensor is at absolute pressure of zero. For gage or differential pressure sensors there is zero differential pressure when both sides of the diaphragm are subject to the same pressure.

Offset Warm-up Shift: The change in output offset voltage that may occur when power is applied to the sensor during the first hour of operation. All Sensors tests all low pressure sensors

for this parameter. Because most of the companies low pressure sensors use dual die electrical cross coupling compensation there is inherent offset warm-up shift compensation in even the most basic sensors.

Operating Range: The pressure range over which the sensor has been tested. For sensors with millivolt output this range can generally be extended to at least twice the range specified with only minor degradation to specifications. For amplified output sensors the range can be extended only ten percent before the output is "railed" to the output voltage limit.

Output Span: Is the output voltage for the specified operating pressure range. For sensors without internal voltage reference the span is ratiometric to the supply voltage of the sensor. Changes in the supply voltage to the sensor with result in a change in output span for the pressure applied. The span is the difference in output voltage at full scale pressure from the offset voltage.

Over-Pressure – Maximum: The maximum normal mode (measured) pressure that can be applied without changing the transducer's performance or accuracy beyond the specified limits. This would be applied to either port of a differential transducer. This is also called "proof pressure".

Overall Accuracy – Calibrated: The combined error band relative to the BSL with forced reference unique to one specific transducer. It excludes offset and sensitivity calibration errors. It includes all other offset and span errors: temperature, repeatability, stability, linearity and hysteresis.

Overall Accuracy – Interchangeable: The combined error band relative to an ideal transducer response characteristic. It excludes stability errors because stability error is already included in specified calibration error. It includes all other offset and span errors: calibration, temperature, repeatability, linearity and hysteresis.

Proof Pressure: is the maximum pressure that may be applied to the sensor without causing any changes in performance to the specifications.

Reference Pressure: The pressure used as a reference in measuring transducer errors.

Reference Temperature: The temperature used as reference in measuring transducer errors.

Repeatability: The error band expressing the ability of the transducer to reproduce an output signal parameter (such as offset or span), at specified pressures and temperature, after exposure to any other pressure and temperature within the specified range.

Sensitivity: The ratio of output signal voltage change to the corresponding input pressure change. Sensitivity is determined by computing the ratio of span to the specified input pressure range.

Sensitivity Calibration: The error band defined by the maximum error in calibrating sensitivity.

Span: The arithmetic difference in transducer output signal measured at the specified minimum and maximum operating pressures.

Span Error: The normal mode error band defined by the maximum deviation of span from its specified value. It may include sensitivity calibration temperature, linearity, hysteresis, repeatability and stability deviations.

Span Repeatability: The error band expressing the ability of a transducer to reproduce its span, measured at 25°C, after exposure to any other pressure and temperature within the specified range.

Span Temperature Coefficient: The error band defined by the maximum deviation of the span as the temperature is varied from 25°C to any other temperature within the specified range.

Span Stability: The error band expressing the ability of the transducer to maintain the span voltage at any pressure within the specified range with temperature held constant.

Stability: The error band expressing the ability of a transducer to maintain the value of an output parameter (such as offset or span) with constant temperature and pressure inputs.

Temperature Coefficient (TC): The error band resulting from maximum deviation of a transducer output parameter (such as offset or span) as temperature is varied from 25°C to any other temperature within the specified range. It is usually measured in (ppm/°C or $\mu\text{V}/\text{V}/^\circ\text{C}$).

Vacuum: A perfect vacuum is the absence of gaseous fluid.

Vacuum Range: The range of absolute pressures between a perfect vacuum (0 psia) and one standard atmosphere (14.697 psia).

Vacuum Transducer: A transducer scaled for pressure measurement in the vacuum range. This is usually an absolute transducer, but sometimes a gage transducer.

Worst-Case Error: The error band obtained by simple addition of all applicable errors specified for the transducer.

Pressure Unit Conversion Constants

(Most commonly used - per international conventions; * = exact conversion factor)

ALL SENSORS®

TO OBTAIN ▶	Pounds Per Square Inch	in. H ₂ O (at 39.2°F)	in. Hg (at 32°F)	Kilopascal (Pa = N/m ²)	Millibar	cm H ₂ O (at 4°C)	mm Hg (at 0°C) (Torr)	kgf/cm ²	Atmosphere (standard)
Pounds Per Square Inch	1.000	27.681	2.036	6.8948	68.948	70.309	51.715	7.0307 x 10 ⁻²	6.805 x 10 ⁻²
in. H ₂ O (at 39.2°F)	3.6126 x 10 ⁻²	1.000	7.3554 x 10 ⁻²	0.2491	2.491	2.5400*	1.8683	2.54 x 10 ⁻³ *	2.458 x 10 ⁻³
in. Hg (at 32°F)	0.4912	13.595	1.000	3.3864	33.864	34.532	25.400*	3.4531 x 10 ⁻²	3.342 x 10 ⁻²
Kilopascal (Pa = N/m ²)	0.14504	4.0147	0.2953	1.000	10.000*	10.1973	7.5006	1.0197 x 10 ⁻²	9.8692 x 10 ⁻³
Millibar	0.01450	0.40147	0.02953	0.100*	1.000	1.01973	0.75006	1.0197 x 10 ⁻³	9.8692 x 10 ⁻⁴
cm H ₂ O (at 4°C)	1.4223 x 10 ⁻²	0.3937	2.8958 x 10 ⁻²	0.09806	0.9806	1.000	0.7355	1.0 x 10 ⁻³	9.678 x 10 ⁻⁴
mm Hg (at 0°C) (Torr)	1.9337 x 10 ⁻²	0.53525	3.9370 x 10 ⁻²	0.13332	1.3332	1.3595	1.000	1.3595 x 10 ⁻³	1.3158 x 10 ⁻³
kgf/cm ²	14.223	393.71	28.959	98.0665	9.8067 x 10 ²	1.000 x 10 ³	7.3556 x 10 ²	1.000	0.9678
Atmosphere (standard)	14.696	406.79	29.921	1.0133 x 10 ²	1.0133 x 10 ³	1.033 x 10 ³	7.600 x 10 ²	1.0332	1.000

▶ **M U L T I P L Y** ▶