

SERIES **FIVE**

MAKE NO
COMPROMISES

Amphenol
Aerospace

UP TO
20%
SMALLER

UP TO
50%
LIGHTER

**Higher
Voltage
CAPABILITIES**

Than 38999 Series III



The World's Most Advanced
CONNECTOR

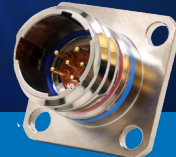

MILITARY • AEROSPACE • HARSH ENVIRONMENT • GENERAL DUTY

TABLE OF CONTENTS



MAKE NO
COMPROMISES

Table of Contents

About

Evolution	3
-----------------	---

Technical Data

Isolated Features	4-5
Small • Lighter • Superior	6
Contact Ratings, Contacts, Sealing Plugs, Tools	7
Voltage Rating and Test Data.....	8
Insert Availability and Identification.....	9
Insert Arrangements	10

Series V

How to Order	11
Keyway Rotations	12
Plug with Accessory.....	13
Wall Mount Receptacle	14
Wall Mount Receptacle with Clinch Nuts.....	15
Jam Nut with Integral Banding Platform	16
S-5 Mini-Band Termination.....	17

PCB Contacts Information

Board Layout for PCB- Termination	18-22
---	-------

Plating

AP-93 Rating	23
--------------------	----



EVOLUTION

The MIL-DTL-38999 series of connectors was born in the 1960's to provide a ruggedized military solution featuring smaller contacts and higher density insert patterns than the already popular MIL-DTL-5015. In the decades since, D38999 connectors have increased in popularity and have become the standard in Mil-Spec connectors for military and aerospace applications.



1964

MIL-DTL-38999
Series II



1966

MIL-DTL-38999
Series I



1976

MIL-DTL-38999
Series III

Along the way, continuous evolutions have brought about new shell styles, new coupling methods, new derivatives and new capabilities, all while remaining as popular as ever. Amphenol's new Series V connector is the next evolutionary step in that impressive lineage, combining all of the capabilities of the traditional 38999 style connector in a lighter, smaller and more compact package to support the ever changing demands of the aerospace industry.

2021

SERIES FIVE



ISOLATED FEATURES

SERIES FIVE E

38999-QUALIFIED INSULATOR



NO DIELECTRIC BOND JOINT

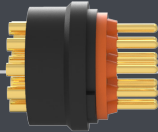

TRIPLE WEB WIRE SEAL

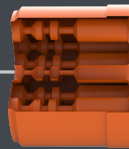

AS39029-QUALIFIED GOLD-PLATED CONTACTS



FULL METAL CLIP CONTACT RETENTION

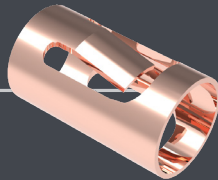

STANDARD ACCESSORY THREAD



RADIAL INTERFACIAL SEAL

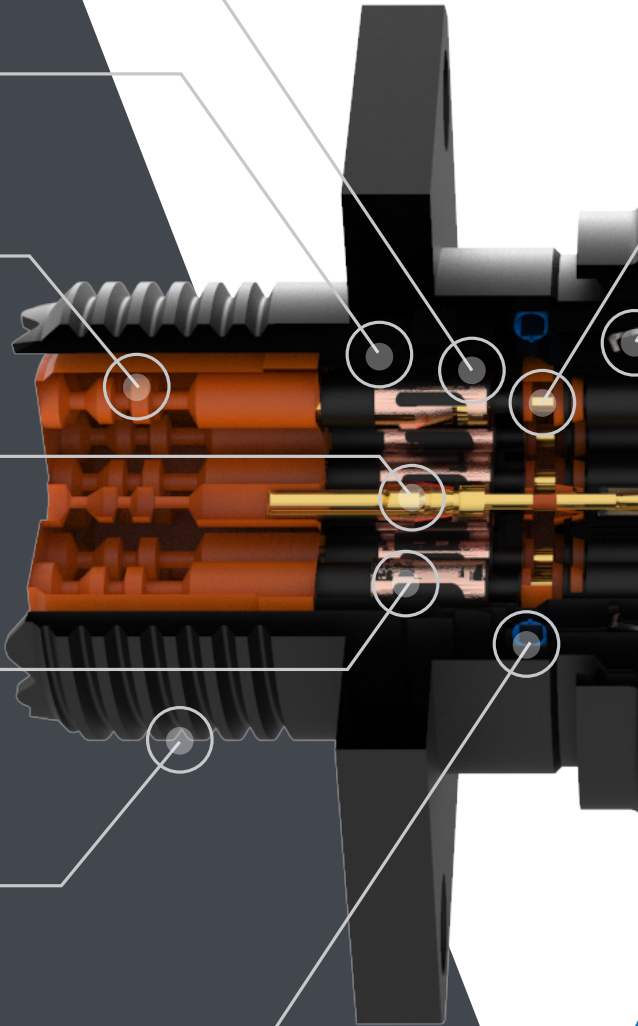
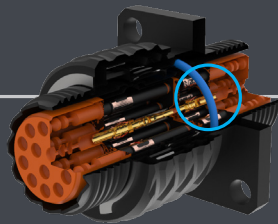

MAKE NO
COMPROMISES

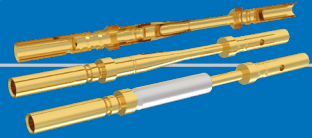
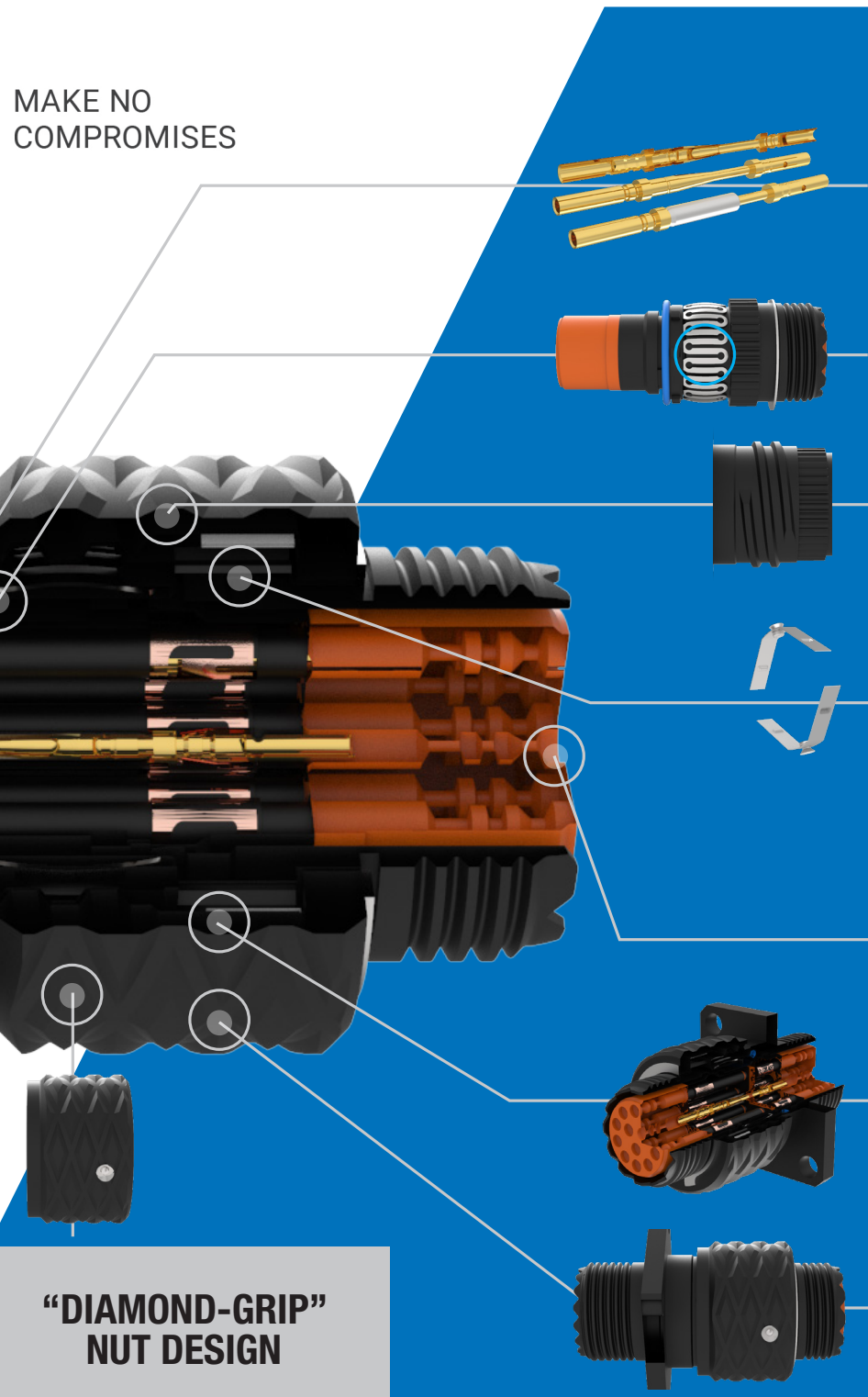

SCOOP PROOF

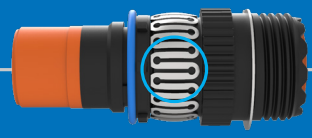

**38999-
QUALIFIED EMI SPRING**



**NO-MESS DRY FILM
THREAD LUBRICANT**



**OPTIMIZED
RATCHETING TORQUE**

NO "BIRD BATH"

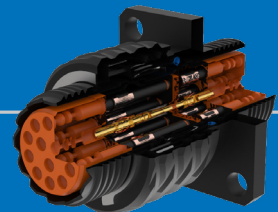

**"NO-SLOP" TOLERANCE
INTERFACE**



**QUICK COUPLING
DOUBLE
START THREAD**

**"DIAMOND-GRIP"
NUT DESIGN**



SMALLER • LIGHTER • SUPERIOR



PLUG WEIGHTS*

Shell Size	Plug Weights (oz.)		
	38999 Series III Plug	Series V Plug	Weight Savings
Size 8	0.463	0.244	47%
Size 10	0.639	0.336	47%
Size 12	0.847	0.556	34%
Size 14	1.318	0.716	46%

*Corresponding 22D insert arrangement, with socket contacts included

WALL MOUNT RECEPTACLE WEIGHTS*

Shell Size	Receptacle Weights (oz.)		
	38999 Series III Wall Mount	Series V Wall Mount	Weight Savings
Size 8	0.325	0.188	42%
Size 10	0.363	0.273	25%
Size 12	0.486	0.371	24%
Size 14	0.646	0.490	24%

*Corresponding 22D insert arrangement, with pin contacts included



SERIES V

Contact Ratings, Contacts, Sealing Plugs, and Crimping Tools

SERIES V CONTACT RATING

Contact Size	Test Current (Amps)	Maximum Millivolt Drop Crimp*	Current with High Current Pins (HCP)
	Crimp		
23	5	73	7.5
22D	5	73	8
20	7.5	55	11
16	13	49	16
12	23	42	25

*When tested using silver plated wire.

Contact Size	Crimp Well Data	
	Well Diameter	Normal Well Depth
23	.0345 ± .0010	.141
22D	.0345 ± .0010	.141
20	.047 ± .001	.209
16	.067 ± .001	.209
12	.100 ± .002	.209

SERIES V CRIMP CONTACTS

Contact Size	Pins Military No.	Socket Military No.
22D	M39029/58-360	M39029/57-354
20	M39029/58-363	M39029/57-357
16	M39029/58-364	M39029/57-358
12	M39029/58-365	M39029/57-359

Above part numbers include standard finish designation - gold plating over suitable underplate in accordance with MIL-DTL-39029. For other finishes, consult Amphenol Aerospace.

SERIES V SEALING PLUGS

Contact Size	Commercial No.	Military No.
22D	10-405996-222	MS27488-22-2
20	10-405996-202	MS27488-20-2
16	10-405996-162	MS27488-16-2
12	10-405996-122	MS27488-12-2

Partial Listing. If you do not see the contact for your application, consult Amphenol Aerospace.

SERIES V CRIMP TOOLS

Contact Size	Pins Military No.	Socket Military No.
22D Socket	M22520/2-01	M22520/2-06
	M22520/7-01	M22520/7-06
22D Pin	M22520/2-01	M22520/2-09
	M22520/7-01	M22520/7-04
20 Pin and Socket	M22520/1-01	M22520/1-04
	M22520/2-01	M22520/2-10
	M22520/7-01	M22520/7-08
16 Pin and Socket	M22520/1-01	M22520/1-04
	M22520/7-01	M22520/7-04
12 Pin and Socket	M22520/1-01	M22520/1-04

SERIES V INSERTION TOOLS

Contact Size	Pins Military No.	Color Code
22D	M81969/14-01*	(Green) White
20	M81969/14-10*	(Red) Orange
16	M81969/14-03*	(Blue) White
12	M81969/14-04*	(Yellow) White

SERIES V REMOVAL TOOLS

Contact Size	Pins Military No.	Color Code
22D	M81969/14-01*	(Green) White
20	M81969/14-10*	(Red) Orange
16	M81969/14-03*	(Blue) White
12	M81969/14-04*	(Yellow) White

*Double ended insertion/removal tool



SERIES V

Voltage Rating and Test Data

VOLTAGE COMPARISON CHART

D38999 Series III				Series 5								
Service Rating	Suggested Oper. Voltage (D38999)- Sea Level		Test Voltage (Unmated)	Service Rating	Qualification Voltage (Mated)				Suggested Oper. Voltage Sea Level (Unmated)		Test Voltage (Unmated) (VRMS)	Insulation Resistance
	AC (RMS)	DC	Sea Level		Sea Level	50,000 FT.	75,000 FT.	100,000 FT.	AC (RMS)	DC	Sea Level	
N	300	450	1000	N	1000	400	260	200	300	450	1000	5,000 MΩ
M	400	500	1300	X	2500	1800	1200	1200	825	1000	2000	5,000 MΩ
I	600	850	1800	Y	3000	2500	2000	1800	1000	1300	2500	5,000 MΩ
II	900	1250	2300	Z	3500	2500	2000	1800	1150	1500	2500	5,000 MΩ

Please note that the establishment of electrical safety factors is left entirely in the designer's hands, since they are in the best position to know what peak voltage, switching surges, transients, etc. can be expected in particular circuit.

TYPICAL SHIELDING EFFECTIVENESS TEST DATA

EMI/EMP SHIELDING EFFECTIVENESS dB
TESTING BY TRIAXIAL METHOD

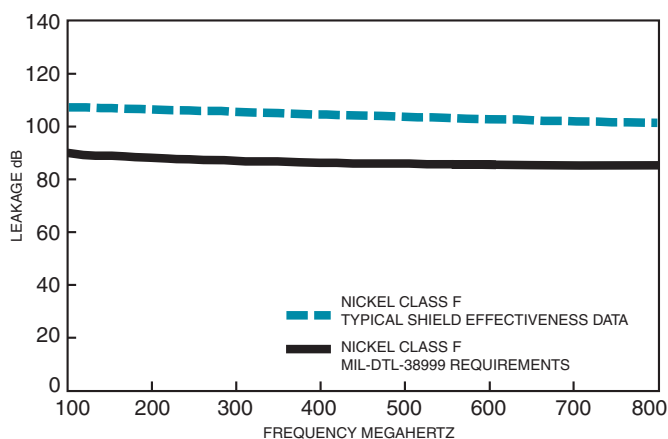

TYPICAL SHIELDING EFFECTIVENESS TEST DATA

EMI/EMP SHIELDING EFFECTIVENESS dB
TESTING BY MODE STIRRING METHOD

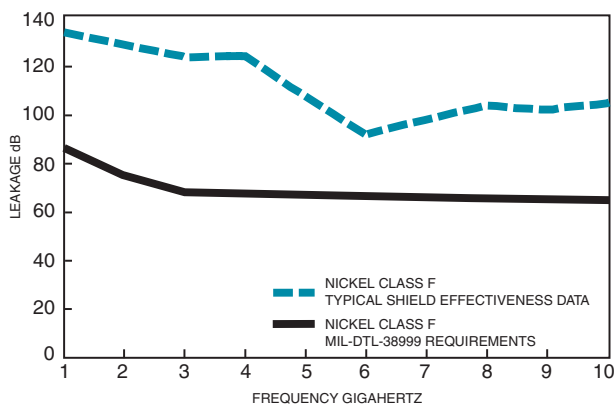

VIBRATION CRITERIA

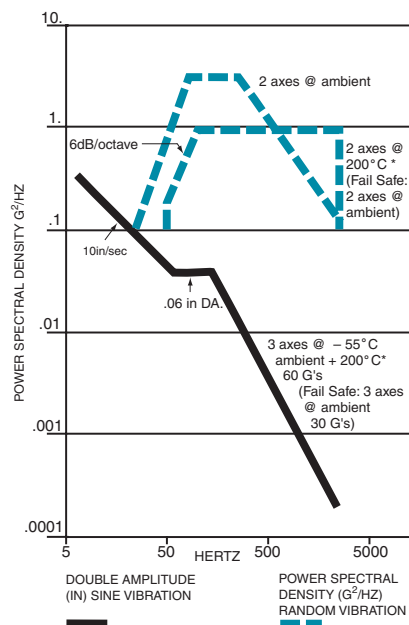

SERIES V

Insert Availability and Identification Chart

Series V	Total Contacts	Service Rating	23	22D	20	16	12
8-35	6	X		6			
8-98	3	Y			3		
8-9	9	N	9				
10-2	2	Y				2	
10-4	4	Y			4		
10-5	5	Y			5		
10-19	19	N	19				
10-35	13	X		13			
10-98	6	Y			6		
10-99	7	Y			7		
12-3	3	Z				3	
12-4	4	Y				4	
12-8	8	Y			8		
12-32	32	N	32				
12-35	22	X		22			
12-98	10	Y			10		
14-4	4	Y					4
14-5	5	Z				5	
14-15	15	Y			14	1	
14-18	18	Y			18		
14-19	19	Y			19		
14-35	37	X		37			
14-55	55	N	55				
14-68	8	Y				8	
14-97	12	Y			8	4	



MAKE NO
COMPROMISES



SERIES V

Insert Arrangements

Front face of pin inserts illustrated

Shell Size &
Insert Arrg. for:

Series V

Service Rating
Number of Contacts
Contact Size

8-9	8-35	8-98	10-2	10-4	10-5
X	Y	N	Y	Y	Y
9	6	3	2	4	5
23	22D	20	16	20	20

Shell Size &
Insert Arrg. for:

Series V

Service Rating
Number of Contacts
Contact Size

10-19	10-35	10-98	10-99	12-3	12-4
N	X	Y	Y	Z	Y
19	13	6	7	3	4
23	22D	20	20	16	16

Shell Size &
Insert Arrg. for:

Series V

Service Rating
Number of Contacts
Contact Size

12-8	12-32	12-35	12-98	14-4	14-5	14-15
Y	N	X	Y	Y	Z	Y
8	32	22	10	4	5	14
20	23	22D	20	12	16	20 16

Shell Size &
Insert Arrg. for:

Series V

Service Rating
Number of Contacts
Contact Size

14-18	14-19	14-35	14-55	14-68	14-97
Y	Y	X	N	Y	Y
18	19	37	55	8	8 4
20	20	22D	23	16	20 16



CONTACT LEGEND 12 16 20 22D 23



1. Connector Type	2. Shell Style	3. Service Class	4. Shell Size - Insert Arrg.	5. Contact Type	6. Alternate Positions	7. Mod (Optional)
-------------------	----------------	------------------	------------------------------	-----------------	------------------------	-------------------

S5

06

DS

14-35

P

N

(453) Space Grade
(HCP) High Current Pin (Increased Amperage)*
(V25) PCB contacts installed, .250" stickout
(V25AD) PCB contacts installed, .250" stickout w. alignment disk
(V25T) PCB contacts installed, .250" stickout, pre-tinned
(V25ADT) PCB contacts installed, .250" stickout, pre-tinned, w. alignment disk

* See page 7 for current rating Contact factory for more options & custom solutions

1. Connector Type

S5 Series 5

2. Shell Style*

00	Wall Mount Receptacle pg 14	06	Straight Plug pg 13
10	Wall Mount with Clinch Nuts pg 15	87	Jam Nut/ w Integral Banding Platform pg 16

*Other shell styles available consult Amphenol for more information

3. 175°C Service Class

DT	Durmalon plated, alternative to cadmium. Corrosion resistant, 500 hour extended salt spray	
DZ	Black Zinc-Nickel alternative to cadmium. 500 hour salt spray, conductive	
DW	Corrosion resistant olive drab cadmium plated aluminum, 1,000 hour extended salt spray	

3. 200°C Service Class

DR	Electroless nickel plated aluminum, 48 hour salt spray	
DS*	AP-93 Tri-Nickel Alloy, Aluminum, 1000 Hr., 200°C, -65dB@100Hz* *See page 19 for more info	
RK	Corrosion resistant stainless steel, firewall capability, plus 500 hour salt spray resistance	
RS	Nickel plated, corrosion resistant steel, firewall capability, 500 hour salt spray	

6. Alternate Positions

N	Normal Rotation
A	A Rotation
B	B Rotation
C	C Rotation
D	D Rotation
E	E Rotation

See pages 12 for more information

5. Contact Type

P	* Pin (Recommended for receptacles)
S	Socket (Recommended for plugs)

*Scoop proof in this configuration

4. Shell Size/ Insert Arrangement

See pages 9-10



SERIES V

Keyway Rotation Table

KEY/KEYWAY POSITION

A plug with a given rotation letter will mate with a receptacle with the same rotation letter. The angles for a given connector are the same whether it contains pins or sockets. Master key stays fixed, minor keys rotate. Inserts are not rotated in conjunction with the master key/keyway.

6. ALTERNATE KEYING					
Shell Size	Key & Keyway Arrangement Identification Letter	AR° or AP° BSC	BR° or BP° BSC	CR° or CP° BSC	DR° or DP° BSC
8	N	105	140	215	265
	A	102	132	248	320
	B	80	118	230	312
	C	35	140	205	275
	D	64	155	234	304
10 12 14	E	91	131	197	240
	N	95	141	208	236
	A	113	156	182	292
	B	90	145	195	252
	C	53	156	220	255
	D	119	146	176	298
	E	51	141	184	242

RECEPTACLE
(FRONT FACE SHOWN)

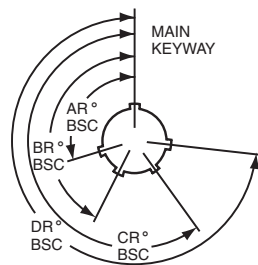

PLUG
(FRONT FACE SHOWN)

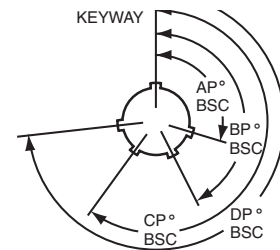

SERIES V PLUG WITH ACCESSORY THREADS

S506

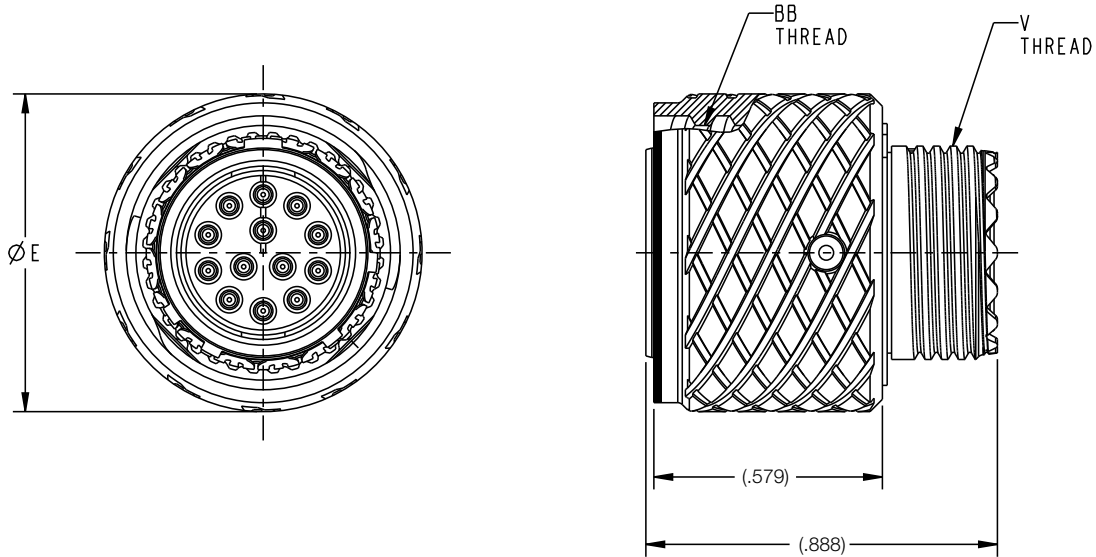

Shell Size	BB Thread	V Thread*	(ØE)
8	.5600 - .1P - .2L - DS	.4375 - 28 - UNEF	.682
10	.6800 - .1P - .2L - DS	.5625 - 24 - UNEF	.803
12	.8000 - .1P - .2L - DS	.6875 - 24 - UNEF	.923
14	.9200 - .1P - .2L - DS	.8125 - 20 - UNEF	1.043

*Compatible with all D38999 Series II Accessories



SERIES V WALL MOUNTING RECEPTACLE

S500

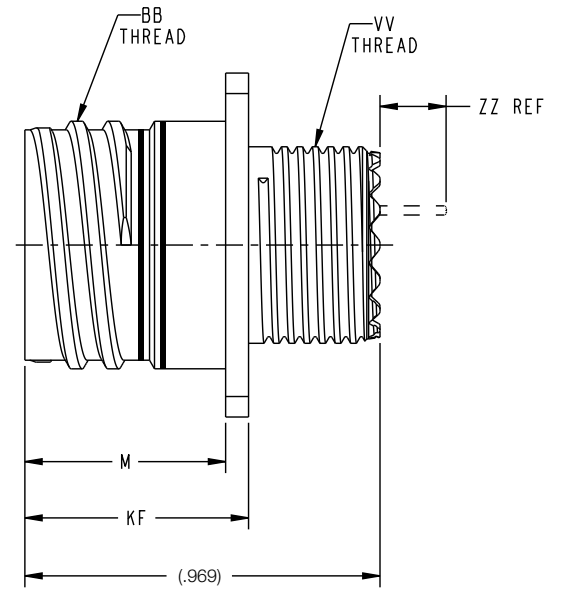
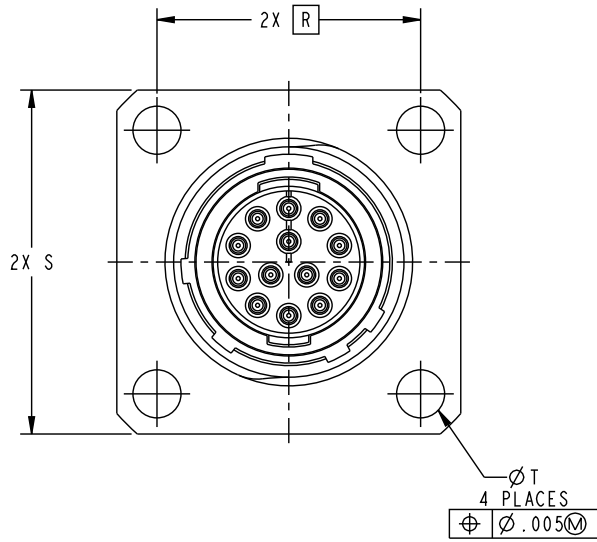

Shell Size	BB Thread	V Thread*	(M)	R	(S)	(ØT)	(KF)	(ZZ)
8	.5600 - .1P - .2L - DS	.4375 - 28 - UNEF	.5475	.594	.812	.131	.610	.250
10	.6800 - .1P - .2L - DS	.5625 - 24 - UNEF	.5475	.719	.938	.131	.610	.250
12	.8000 - .1P - .2L - DS	.6875 - 24 - UNEF	.5475	.812	1.031	.131	.610	.250
14	.9200 - .1P - .2L - DS	.8125 - 20 - UNEF	.5475	.906	1.125	.131	.610	.250

*Compatible with all D38999 Series II Accessories



SERIES V WALL MOUNTING RECEPTACLE WITH CLINCH NUTS

S510

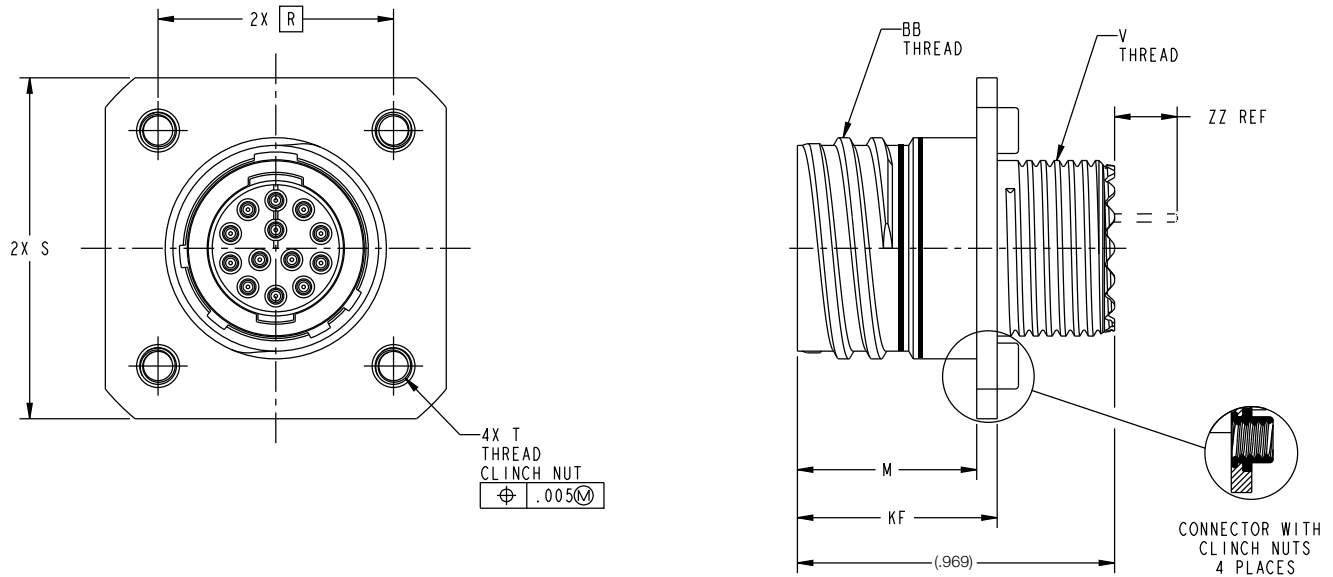

Shell Size	BB Thread	V Thread*	(M)	R	(S)	T Thread	(KF)	(ZZ)
8	.5600 - .1P - .2L - DS	.4375 - 28 - UNEF	.5475	.594	.916	.112-40UNC-3B	.610	.250
10	.6800 - .1P - .2L - DS	.5625 - 24 - UNEF	.5475	.719	1.041	.112-40UNC-3B	.610	.250
12	.8000 - .1P - .2L - DS	.6875 - 24 - UNEF	.5475	.812	1.134	.112-40UNC-3B	.610	.250
14	.9200 - .1P - .2L - DS	.8125 - 20 - UNEF	.5475	.906	1.228	.112-40UNC-3B	.610	.250

*Compatible with all D38999 Series II Accessories



SERIES V JAM NUT - INTEGRAL BANDING PLATFORM

S587

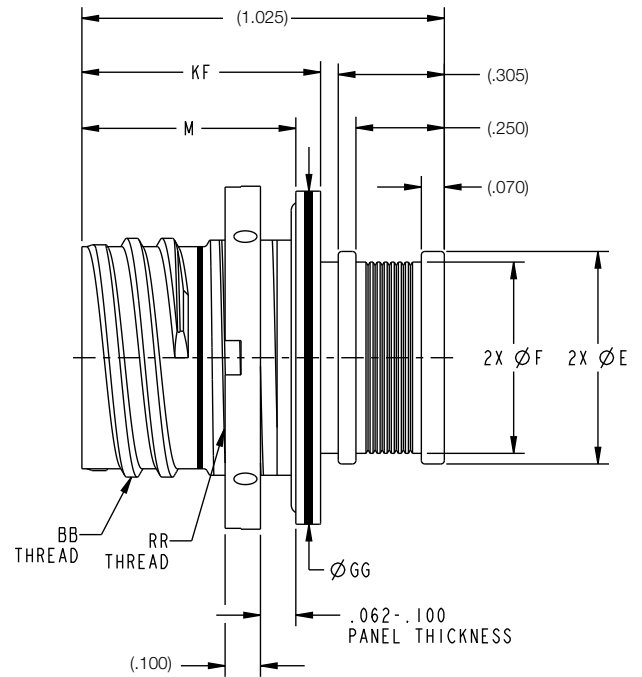
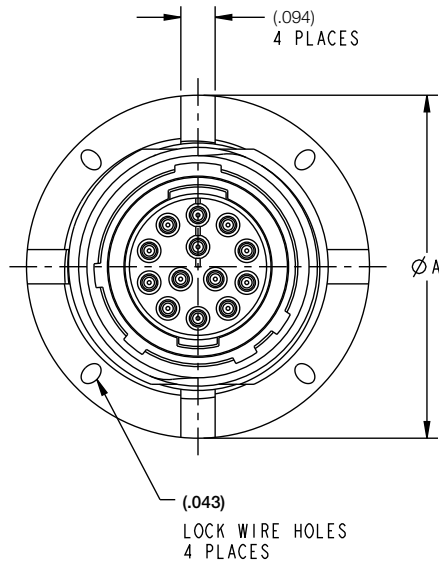

Shell Size	($\varnothing A$)	($\varnothing E$)	($\varnothing F$)	(M)	BB Thread	($\varnothing GG$)	(KF)	RR Thread
8	.825	.425	.425	.605	.5600 - .1P - .2L - DS	.822	.675	.6250 - 24 - UNEF - 2A
10	.975	.606	.546	.605	.6800 - .1P - .2L - DS	.947	.675	.7500 - 20 - UNEF - 2A
12	1.096	.731	.671	.605	.8000 - .1P - .2L - DS	1.072	.675	.8750 - 20 - UNEF - 2A
14	1.275	.865	.805	.605	.9200 - .1P - .2L - DS	1.252	.675	1.000 - 20 - UNEF - 2A



S5 MINI-BAND TERMINATION

Mini-band Termination: For assembling cables to overmolded style S5 connectors or backshells, the Mini-band system offers quick termination of cable shields and flexibility to be utilized on a wide range of parts with just one band size. These rugged straps have passed numerous hazardous environmental testing. Including shock and vibration. Approved for use in military and aerospace applications.

MATERIALS:

Mini-band installation tool. Use with .120" (3.05 mm) wide bands, 6.75 inches (172 mm.) length, 1.2 pounds (0.6 Kg.)

Mini-band, .120" (3.05 mm) wide. Available in two lengths, flat or pre-coiled. Stainless steel.



Description	DMC Part Number	Military Part Number
Mini-Band Installation Tool	DBS-2200	M81306/1B

Length		Accommodates Diameter		DMC Part Number	Military Part Number
Inches	mm	inches	mm		
8.125	206.38	.88	22.35	DBS-1287	M85049/128-7



Step 1: Prepare the Connector and Cable Braid

Prepare the connector and cable braid for band termination process (see DMC Website).

Step 2: Prepare Band

Using an appropriate size band, feed the end of the band through the narrow slot on the buckle twice. This will create a double-looped band. Never use a single-looped band. To hasten the termination process on smaller adapters, pull on the end of the band to reduce the diameter of the loop.

Step 3: Insert Looped Band into Tool

Squeeze the release lever and insert the end of the band into the nose of the tool. Ensure the orientation of the band matches the graphic on the body of the tool (coil down when the tool is held upright).

Step 4: Positioning

Position the connector and the shield assembly through the band.

Step 5: Tighten Band around Braid/Connector

Repeatedly squeeze the tensioning handle until the band closes around the assembly. Once the band is closed around the assembly, use half strokes of the handle until the band is tight against the braided cable. Release the tensioning handle and allow it to open fully. With one final stroke, close the tensioning handle until it locks against the tool body. This indicates that the band has been tightened to the pre-set tension.

Step 6: Cut Off

Once the tensioning handle is locked in place, squeeze the cut-off handle to finish the termination process. Both handles will open up on their own. (If shrinkable tubing is to be applied, it is recommended that the band is wrapped in tape and the excess braid folded back over the band to prevent cutting of shrinkable tubing).

Step 7: Remove Excess Band Material

Release the tensioning handle and then squeeze the release lever. While squeezing the release lever, carefully pull on the band and slide it out of the tool and discard.



BOARD LAYOUT FOR PCB-TERMINATION

INSERT ARRANGEMENT #8-35

Connector Type:	Series V	Number of Contacts	Contact Size
Insert Designation:	8-35	6	22D

Contact Locations

Front face of pin insert shown

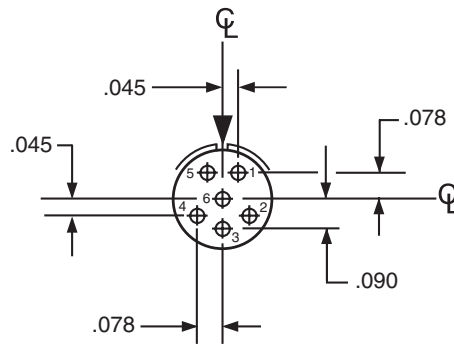

All dimensions for reference only. Note: Shown in this catalog are the most common insert patterns for PCB applications. For availability of other arrangements, consult Amphenol Aerospace.



BOARD LAYOUT FOR PCB-TERMINATION

INSERT ARRANGEMENT #8-98

Connector Type:	Series V	Number of Contacts	Contact Size
Insert Designation:	8-98	3	20

Contact Locations

Front face of pin insert shown

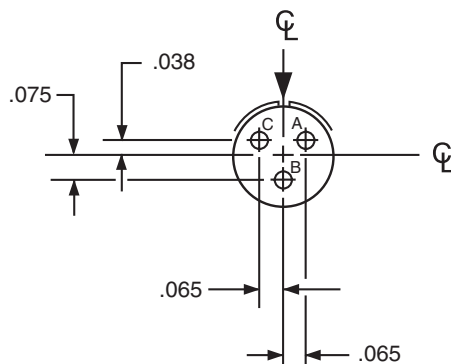

INSERT ARRANGEMENT #10-5

Connector Type:	Series V	Number of Contacts	Contact Size
Insert Designation:	10-5	5	20

Contact Locations

Front face of pin insert shown

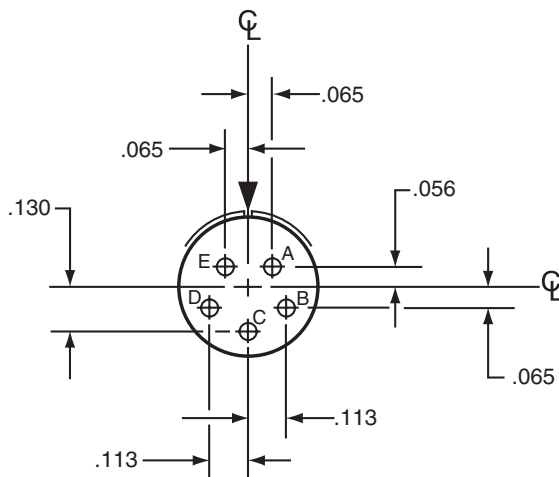

All dimensions for reference only. Note: Shown in this catalog are the most common insert patterns for PCB applications. For availability of other arrangements, consult Amphenol Aerospace.



BOARD LAYOUT FOR PCB-TERMINATION

INSERT ARRANGEMENT #10-35

Connector Type:	Series V	Number of Contacts	Contact Size
Insert Designation:	10-35	13	22D

Contact Locations

Front face of pin insert shown

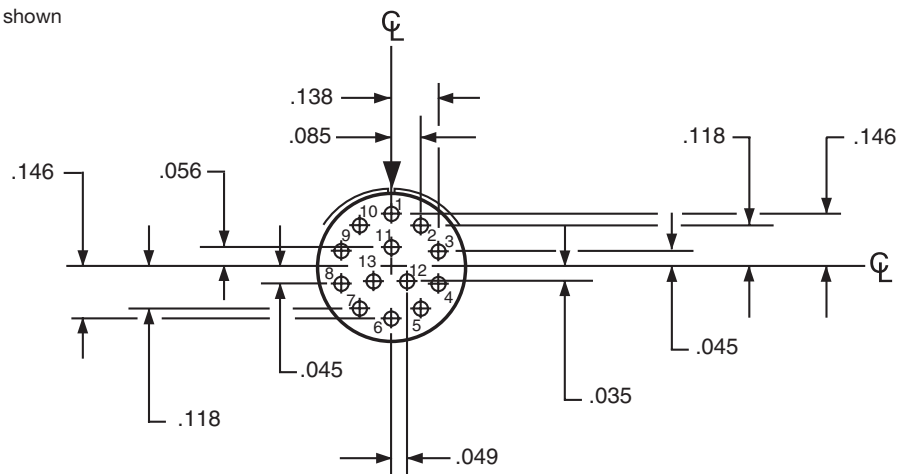

INSERT ARRANGEMENT #12-3

Connector Type:	Series V	Number of Contacts	Contact Size
Insert Designation:	12-3	3	16

Contact Locations

Front face of pin insert shown

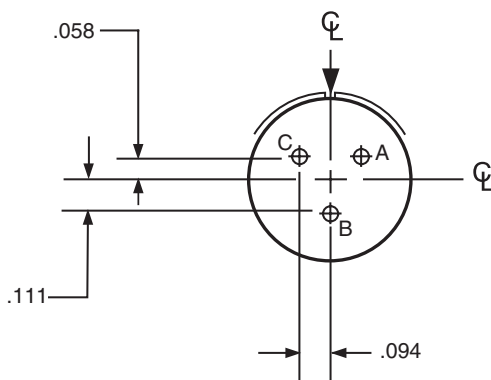

All dimensions for reference only. Note: Shown in this catalog are the most common insert patterns for PCB applications. For availability of other arrangements, consult Amphenol Aerospace.



BOARD LAYOUT FOR PCB-TERMINATION

INSERT ARRANGEMENT #12-35

Connector Type:	Series V	Number of Contacts	Contact Size
Insert Designation:	12-35	22	22D

Contact Locations

Front face of pin insert shown

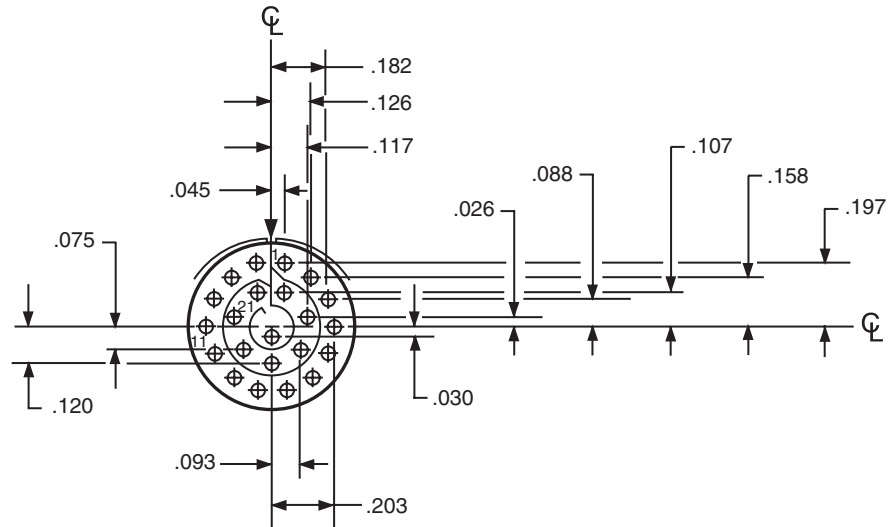

INSERT ARRANGEMENT #14-18

Connector Type:	Series V	Number of Contacts	Contact Size
Insert Designation:	14-18	18	20

Contact Locations

Front face of pin insert shown

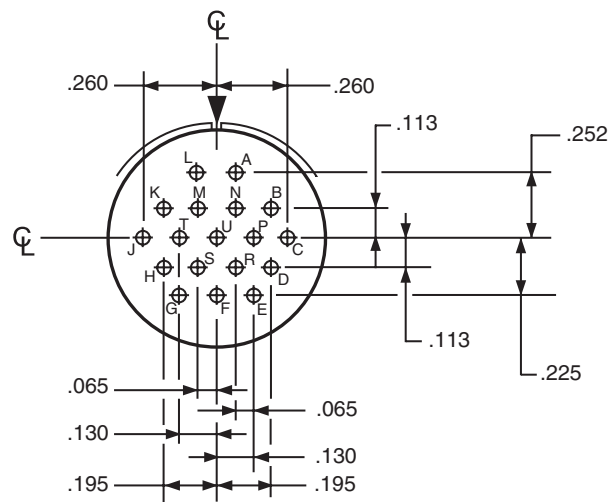

All dimensions for reference only. Note: Shown in this catalog are the most common insert patterns for PCB applications. For availability of other arrangements, consult Amphenol Aerospace.



BOARD LAYOUT FOR PCB-TERMINATION

INSERT ARRANGEMENT #14-19

Connector Type:	Series V	Number of Contacts	Contact Size
Insert Designation:	14-19	19	20

Contact Locations

Front face of pin insert shown

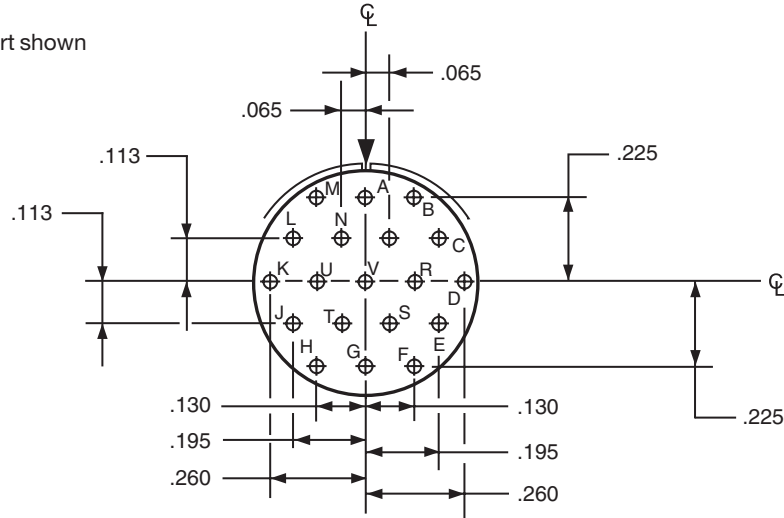

INSERT ARRANGEMENT #14-35

Connector Type:	Series V	Number of Contacts	Contact Size
Insert Designation:	14-35	37	22D

Contact Locations

Front face of pin insert shown

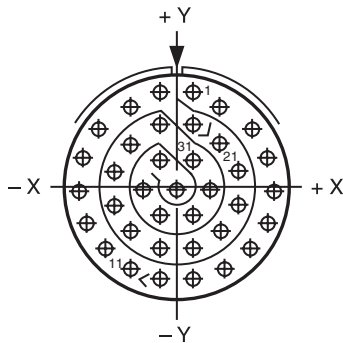

Contact Hole Locations			Contact Hole Locations		
Contact Number	Location		Contact Number	Location	
	X Axis	Y Axis		X Axis	Y Axis
1	+045	+262	19	+045	+172
2	+123	+217	20	+123	+119
3	+211	+160	21	+170	+040
4	+254	+080	22	+170	-050
5	+266	-010	23	+123	-127
6	+247	-098	24	+045	-172
7	+200	-175	25	-045	-172
8	+130	-232	26	-123	-127
9	+045	-262	27	-170	-050
10	-045	-262	28	-170	+040
11	-130	-232	29	-123	+119
12	-200	-175	30	-045	+172
13	-247	-098	31	+045	+074
14	-266	-010	32	+090	-004
15	-254	+080	33	+045	-082
16	-211	+160	34	-045	-082
17	-123	+217	35	-090	-004
18	-045	+262	36	-045	+074
			37	.000	-004

All dimensions for reference only. Note: Shown in this catalog are the most common insert patterns for PCB applications. For availability of other arrangements, consult Amphenol Aerospace.



AP-93 PLATING - 1000 HOURS ALTERNATIVE TO CADMIUM

RoHS Compliant Tri-Nickel Alloy, Intermateable with Cadmium



Amphenol Aerospace introduces **AP-93** -- a new, durable REACH/RoHS compliant plating for aluminum connectors which outperforms Cadmium and exceeds 1000 hour salt spray requirements. **AP-93** is a conductive finish that meets or exceeds D38999 Cadmium requirements (under the commercial service class designator "DS") making it an excellent choice for harsh environments.

Military, commercial, and industrial markets continue to move away from Cadmium due to known toxic carcinogens. The new **AP-93** plating finish complies with all customer requirements tied to these specifications. Amphenol is also using European Union Directive 2002/95/EC RoHS as a guide to qualification for all military, commercial, and industrial specifications requiring the reduction or elimination of these restricted materials.

AP-93 is intermateable with Cadmium, making it a drop-in replacement for applications where Cadmium has been a preferred choice. Applications include numerous components of land, sea, air, and weapons systems, as well as space systems, as it provides superior barrier protection and excellent lubricity for threaded applications.

AP-93 exceeds Olive-Drab Cadmium plating (Class W) by meeting 1000 hours of dynamic salt spray, 500 mating cycles, and meets the millivolt drop shell-to-shell conductivity of nickel (Class F). **AP-93** also meets a 200° C temperature rating, is compatible with other platings, and is available on all D38999-style connectors. For specific applications please contact Amphenol Aerospace.

FEATURES & BENEFITS

- Available on all Series V style connectors
- Meets 1000 hour salt spray requirement
- REACH/RoHS compliant
- Intermateable with Cadmium -- excellent drop-in replacement for existing connectors.
- 500 mating cycles per D38999
- Meets 200° C temperature rating
- Meets D38999 shell-to-shell conductivity requirements

Requirements	Nickel	CAD	AP-93
336 Hours SO2 Exposure			*
500 Hours Salt Spray		*	*
1000 Hours Salt Spray			*
REACH/RoHS Compliant	*		*
CAD Intermateable		*	*
Non-Magnetic	*	*	*
Temperature Rating 200° C	*		*
Shell-to-Shell Conductivity < 2.5 millivolt	*	*	*

Note: Specifications are subject to change without notice.



ABOUT AMPHENOL AEROSPACE

Your Source for Interconnect Products



CONTACT US:

Amphenol Aerospace
40-60 Delaware Avenue
Sidney, NY 13838-1395

Customer Service:

Mon - Fri 8AM - 5PM

Phone: (800) 678-0141

Fax: (607) 563-5157

Online: www.amphenol-aerospace.com



*Amphenol Aerospace, Amphenol Commercial Air,
and Amphenol Industrial Operations Main Facility in Sidney, NY USA*

ABOUT AMPHENOL AEROSPACE:

Amphenol Aerospace, a Division of Amphenol Corporation, is one of the largest manufacturers of interconnect products in the world for the Military, Commercial Aerospace and Industrial markets. Amphenol designs, manufactures and markets circular and rectangular, electronic, fiber optic, EMI/EMP filter, and a variety of special applications connectors and interconnect systems.

Our state-of-the-art facility is nestled at the foothills of the Catskill Mountains in Sidney, NY. The Amphenol complex houses many technologies including CNC machining, die-casting, molding, impact and extruding, plating, screw machining and process controls. Our fully equipped material evaluation lab and engineering organization utilize the latest in computer aided design software and analysis tools, allowing us to design, test, and qualify advanced interconnect systems. Amphenol's interconnect products are supplied to thousands of OEMs worldwide and are supported by our worldwide sales and engineering force, including the largest global network of electronic distributors.



Customer-Centric:

Our #1 **priority** is our customers who deserve quality product on time.

Accountable:

Clear owners, clear actions, clear results.

Reliable:

What we build matters and quality is imperative.

Enthusiastic:

Challenges create rewarding opportunities. Enthusiasm is contagious and we will spread it.

QUALITY ASSURANCE:

Amphenol Aerospace has been awarded both AS9100 - Revision C and ISO9001:2008 Quality Assurance Certifications.

Amphenol

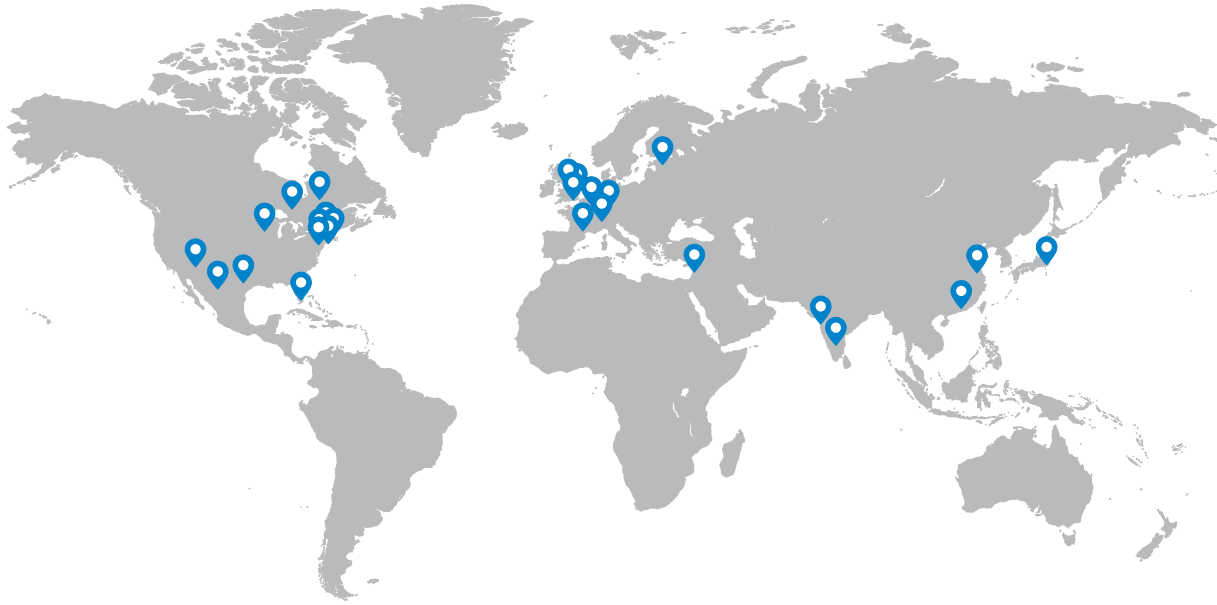

Amphenol Aerospace Operations

40-60 Delaware Avenue
Sidney, NY 13838
800-678-0141

Amphenol Commercial Air Division

40-60 Delaware Avenue
Sidney, NY 13838
1-800-687-0141

Amphenol Nexus Technologies

50 Sunnyside Avenue
Stamford, CT 06902
203-327-7300

Amphenol PCD

72 Cherry Hill Drive
Beverly, MA 01915
978-624-3400

Amphenol SV Microwave

2400 Centrepark West Drive
West Palm Beach, FL
561-840-1800

Amphenol Times Microwave, Inc.

358 Hall Avenue
Wallingford, CT 06492
800-867-2629

Amphenol Fiber Systems International

1300 Central Expressway North, Suite 100
Allen, TX 75013
214-547-2400

Amphenol Borisch Technologies

4511 East Paris AVE
Grand Rapids, MI 49512
616-554-9820

Amphenol Printed Circuits

91 Northeastern Boulevard
Nashua, NH 03062
603-324-4500

Amphenol Canada

605 Milner Avenue
Toronto, ON Canada M1B 5X6
416-291-4401

Amphenol Invotec

Unit 1-3, Hedging Lane Industrial Estate
Dosthill, Tamworth, B77 5HH United Kingdom
+44 (0) 1827 263250

Amphenol Ionix Systems

Prospect House, Taylor Business Park
Risley, Warrington, WA3 6HP United Kingdom
+44 (0) 1942 685200

Amphenol Limited

Thanet Way
Whitstable, Kent, CT5 3JF United Kingdom
+44 (0) 1227 773200

Amphenol Socapex

948 Promenade De L'Arve – BP 29
74311 Thyez France
+33 (0) 4 50 89 28 00

Amphenol Air LB SAS

2 Rue Clément Ader, Zac de Wé
08110 Carignan France
+33 (0) 03 24 22 78 49

Amphenol AirLB GmbH

Am Kleinbahnhof 4
D-66740 Saarlouis Germany
+49 (0) 68 31/98 10 0

Amphenol SEFEE

Z.I. des Cazes – BP243
12402 Saint-Affrique Cedex France
+33 (0) 5 65 98 11 00

Amphenol Interconnect India

105, Bhosari Industrial Area
Pune – 411 026 India
+91 20 27120363

Amphenol Japan, Ltd.

471-1, Deba, Ritto-City
Shiga, 520 3041 Japan
+81 77 553 8501

Amphenol Martec Limited

St. Augustines Business Park
Swalecliffe, Whitstable, Kent
CT5 2QJ United Kingdom
+44 (0) 1227 793 733

Amphenol Optimize

Carretera Internacional Km 6.5
Col. Parque Industrial
Nogales, Sonora, México. C.P. 84094
+52 (631) 311-160

Amphenol Ionix Systems OÜ

Pikk Street 59b
Kuressaare 93815 Estonia
+372 4521 780

AMA0 – European Sales Operations

Via Barbaiana 5
20020 Lainate Milano, Italy
+39 02 932 541

Amphenol Bar-Tec Ltd.

3 Hagavish st
POB 2479 Kfar-Saba 44641
Israel
+972-9-7644100



AMPHENOL CORPORATION

40-60 Delaware Avenue, Sidney, NY 13838-1395 • 800-678-0141
www.amphenol-aerospace.com • www.amphenolmao.com