

Datasheet

Amphenol - Wi-Fi module

W106C



Document information

File Name	Amphenol_W106C_Datasheet
Created	2021-05-16
Total Page	15

Revision History

Version	Date	Note
1.0	2021-05-16	Created
1.1	2022-06-09	Feature updated
1.2	2022-08-18	Pin Description updated

Aim of this Document

The aim of this document is to give a detailed product description and product application including features and performance of the W106C.

Contents

Contents	2
1. Introduction.....	3
2. Module Overview.....	4
2.1 Product Overview	4
2.2 Electrical specifications.....	5
2.3 RF Characteristics	6
3. Type of antenna.....	9
4. Pin Description	9
5. Mechanical	10
6. Recommended footprint	13
7. Reference circuit.....	14
8. Package information.....	15

1. Introduction

W106C modules designed base on RTL8720CF chip solution. This SoC is a highly intelligent platform for the Internet of Everything. It combines a KM4 MCU, WLAN MAC, a 1T1R capable WLAN baseband, RF, and Bluetooth in a single chip. It also provides a bunch of configurable GPIOs which are configured as digital peripherals for different applications and control usage.

1.1 Key Features

- Processor: RTL8720CF
- Wi-Fi
 - ✓ IEEE 802.11b/g/n
 - ✓ 1T1R 2.4GHz Single Frequency
 - ✓ Trust Zone Security boot
- ✓ Support WPA/WPA2 PSK
- ✓ Support WPS, Wi-Fi Direct
- Bluetooth
 - ✓ BLE Ver 4.2

1.2 Application

- ✓ IOT
- ✓ Network Consumer Device
- ✓ Metering
- ✓ Building Automation
- ✓ Home Automation
- ✓ Smart lighting
- ✓ Industry Control

2. Module Overview

W106C is 1x1 802.11 b/g/n module optimized for low-power embedded applications with single-stream capability for both transmit and receive.

W106C supports BLE ver4.2.

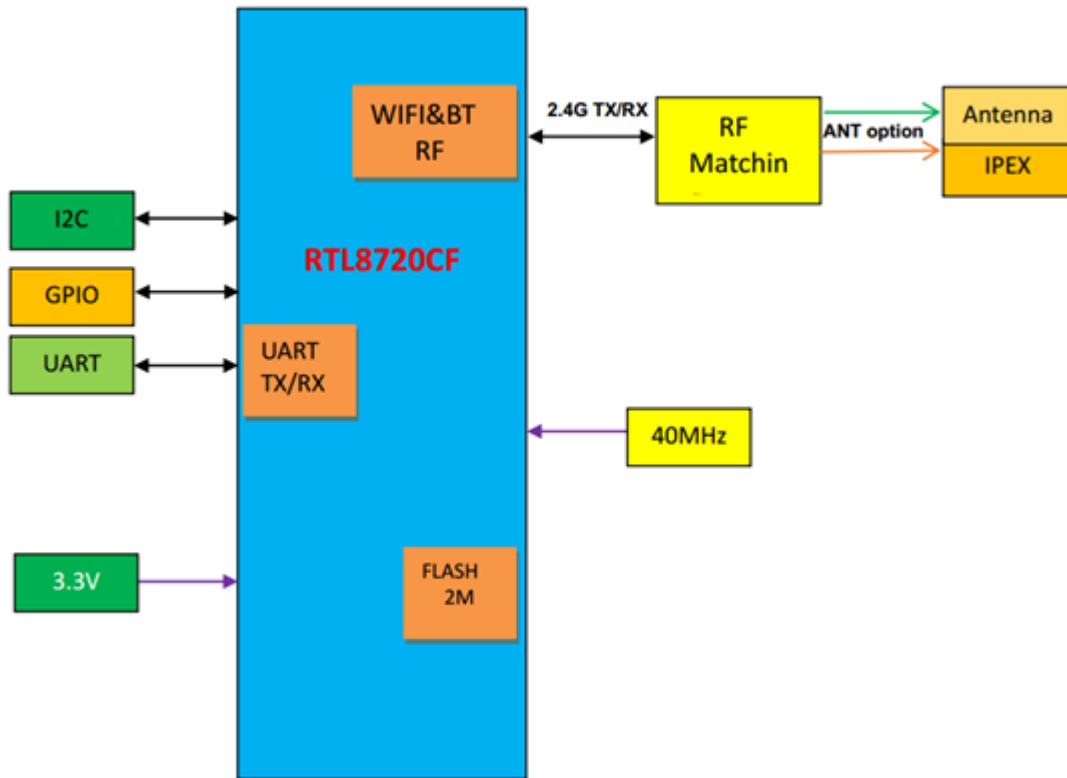

Figure 2-1 Block diagram of W106C

2.1 Product Overview

Table 2-1 Specification of W106C

Wi-Fi	
Standard	IEEE 802.11b/g/n
WLAN PHY	1T1R
BLE	
Version	BLE4.2
RF	
Frequency	2.402GHz to 2.4835GHz
Modulation	802.11b: CCK, DQPSK, DBPSK, DSS

	802.11g: 64-QAM,16-QAM,QPSK,BPSK and OFDM 802.11n: 64-QAM,16-QAM,QPSK,BPSK and OFDM Bluetooth: GFSK
Transmit Rate	802.11b: 1,2,5.5,11 Mbps 802.11g: 6,9,12,18,24,36,48,54 Mbps 802.11n: MCS0~7 BLE: CH0 to CH39
Electrical Character	
Memory	Internal Flash: 2MB
Interfaces	GPIO;UART;I2C
Power supply	3.0V to 3.6V
Operation Temperature	-20°C to +85°C

2.2 Electrical specifications

2.2.1 Absolute maximum ratings

Table 2-2 Absolute maximum rating

Symbol	Description	Min	Max	Unit
VDD	Voltage	-0.3	3.6	V
Power_ANT	Maximum power at receiver		+7	dBm
Temp_Storage	Storage temperature	-40	+125	°C

2.2.2 Maximum ESD rating

Table 2-3 Maximum ESD rating

Parameter	Min	Type	MAX	Unit	Remarks
Electrostatic discharge			±2	KV	Human body model
			±0.5	KV	Charged device model

2.2.3 Micro-controller subsystem

2.2.3.1 Digital Pins

Table 2-4 Digital Pins

Symbol	Note	Conditions	Specification			
			Min.	Typical	Max.	Unit
VIH	Input-High Voltage	LVTTTL	2.0	-	3.6	V
VIL	Input-Low Voltage	LVTTTL	-	-	0.8	V
VOH	Output-High Voltage	LVTTTL	2.4	-	-	V
VOL	Output-Low Voltage	LVTTTL	-	-	0.4	V

2.3 RF Characteristics

2.3.1 IEEE 802.11b mode

Table 2-5 IEEE 802.11b Mode Specification

Item	Specification
Modulation Type	CCK, DQPSK, DBPSK, DSSS
Frequency range	2.402GHz to 2.4835GHz
Channel	CH1 to CH13
Data rate	1, 2, 5.5, 11Mbps

Table 2-6 IEEE 802.11b Mode TX Characteristic

TX Characteristics	Min.	Typical	Max.	Unit
Transmitter Output Power				
11bTarget Power	15	17	19	dBm
Spectrum Mask @ target power				
fc +/- 11MHz to +/-22MHz	-		-30	dBr
fc > +/-22MHz	-		-50	dBr
Frequency Error	-15	-	+15	ppm
Constellation Error(peak EVM)@ target power				
1Mbps	-	-27	-10	dB
2Mbps	-	-	-10	dB
5.5Mbps	-	-	-10	dB
11Mbps	-	-25	-10	dB

Table 2-7 IEEE 802.11b Mode RX Characteristic

RX Characteristics	Min.	Typical	Max.	Unit
Minimum Input Level Sensitivity				
1Mbps (FER \leq 8%)	-	-98	-94	dBm
11Mbps (FER \leq 8%)	-	-90	-86	dBm

2.3.2 IEEE 802.11g mode

Table 2-8 IEEE 802.11g Mode Specification

Item	Specification
Modulation Type	64-QAM, 16-QAM, QPSK, BPSK, OFDM
Frequency range	2.402GHz to 2.4835GHz

Channel	CH1 to CH13
Data rate	6, 9, 12, 18, 24, 36, 48, 54Mbps

Table 2-9 IEEE 802.11g Mode TX Characteristic

TX Characteristics	Min.	Typical	Max.	Unit
Transmitter Output Power				
11gTarget Power	13	15	17	dBm
Spectrum Mask @ target power				
fc +/- 11MHz to +/-20MHz	-		-20	dBr
fc +/-20MHz to +/-30MHz	-		-28	dBr
fc > +/-30MHz			-40	dBr
Frequency Error	-15	-	+15	ppm
Constellation Error(peak EVM)@ target power				
6Mbps	-	-32	-10	dB
54Mbps	-	-32	-25	dB

Table 2-10 IEEE 802.11g Mode RX Characteristic

RX Characteristics	Min.	Typical	Max.	Unit
Minimum Input Level Sensitivity				
6Mbps (FER \leq 8%)	-	-93	-89	dBm
54Mbps (FER \leq 8%)	-	-76	-72	dBm

2.3.3 IEEE 802.11n HT20 section

Table 2-11 IEEE 802.11n Mode Specification

Item	Specification
Modulation Type	64-QAM,16-QAM,QPSK,BPSK,OFDM
Frequency range	2.402GHz to 2.4835GHz
Channel	CH1 to CH13
Data rate	MCS0/1/2/3/4/5/6/7

Table 2-12 IEEE 802.11n Mode TX Characteristic

TX Characteristics	Min.	Typical	Max.	Unit
Transmitter Output Power				
11gTarget Power	12	14	16	dBm
Spectrum Mask @ target power				
fc +/- 11MHz to +/-22MHz	-	-	-20	dBr

fc > +/-22MHz	-	-	-28	dBr
fc > +/-30MHz	-	-	-45	dBr
Frequency Error	-15	-	+15	ppm
Constellation Error(peak EVM)@ target power				
MCS0	-	-34	-5	dB
MCS7	-	-33	-28	dB

Table 2-13 IEEE 802.11n Mode RX Characteristic

RX Characteristics	Min.	Typical	Max.	Unit
Minimum Input Level Sensitivity				
MCS0 (FER \leq 10%)	-	-92	-88	dBm
MCS7 (FER \leq 10%)	-	-73	-69	dBm

2.3.4 BLE Specification

Table 2-14 BLE Specification

Items	Contents			
Channel	CH0 to CH39			
Modulation	GFSK			
TX Characteristics	Min	Type	MAX	Unit
Output Power at NOC	-	-	+4	dBm
Modulation Characteristics				
$\Delta F1_{avg}$	225	255	275	kHz
$\Delta F2_{MAX}$ (For at least 99.9% of all $\Delta F2$)	185	-	-	kHz
$\Delta F2/\Delta F1$	0.8	0.94		Hz/Hz
Carrier Frequency offset and drift				
Frequency offset	-150	-	+150	kHz
Frequency Drift	-50	-	+50	kHz
Max Drift Rate	-20	-	+20	Hz/us
In-Band Spurious Emissions				
+/- 2M offset			-20	dBm
>+/- 3M offset			-30	dBm
RX Characteristics	Min	Type	MAX	Unit
Receiver Sensitivity (BER<30.8%)		-95		dBm
Maximum usable signal (BER<30.8%)		-5		dBm

3. Type of antenna

When using PCB antenna in WIFI module, it is necessary to ensure that PCB and other metal devices are at least 15 mm away from the motherboard. The shaded areas in the figure below need to be far away from metal devices, sensors, interference sources and other materials that may cause signal interference.

Users can choose different 2.4G antennas with different external dimensions and gains not greater than 2dBi according to the application environment.

When using an external antenna, it should be noted that the module must be powered on after the antenna is connected, because the module will perform IQ calibration after power on, and send a single carrier through the PA to pass the RX loop detection signal. If the load is not loaded (the antenna is not connected), it will cause calibration errors, which will make the PA output power abnormal, and a large standing wave will be formed at the PA output, which may damage the internal devices.

4. Pin Description

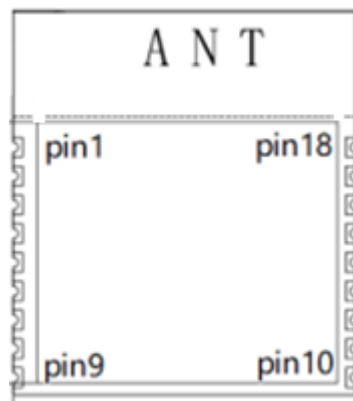

Figure 4-1 W106C Pin_out description

Table 4-1 PIN Definition

Pin Number	Name	PWM	UART	JTAG	I2C	Others
1	VDD					
2	Chip_enable					
3	GPIOA_0	PWM0	UART1_RX	JTAG_CLK		EXT_32K
4	GPIOA_1	PWM1	UART1_TX	JTAG_TMS		
5	GPIOA_2	PWM2		JTAG_TDO	I2C_SCL	

6	GPIOA_3	PWM3	JTAG_TDI	I2C_SDA
7	GPIOA_4	PWM4	JTAG_TRST	
8	GPIOA_7			Reserved
9	GND			
10	GPIOA_8			Reserved
11	GPIOA_13		UART0_RXD	
12	GPIOA_14		UART0_TXD	
13	GND			
14	GPIOA_17	PWM5		
15	GPIOA_18	PWM6		
16	GPIOA_16		UART2_LOG_TXD	
17	GPIOA_15		UART2_LOG_RXD	
18	GND			

5. Mechanical

5.1 Size

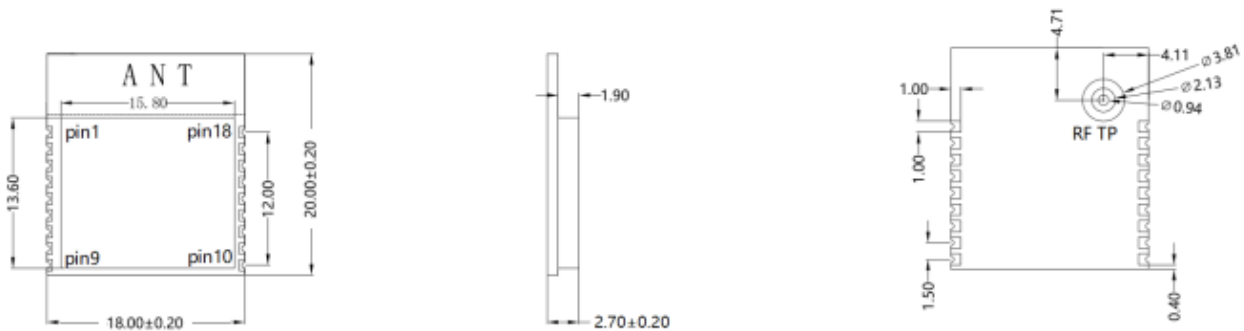

Unit: mm

Figure 5-1 Size

5.2 Use guidelines

A. SMT need machine:

- Reflow soldering SMT machine
- The AOI detector
- 6-8 mm diameter suction nozzle

B. Baking need equipment:

- Cabinet baking box
 - ◆ The antistatic, high temperature resistant tray
 - ◆ The antistatic high temperature resistant gloves
- Storage conditions as follows
 - ◆ Moisture bag must be stored in a temperature $< 30^{\circ}\text{C}$, humidity 85% RH of the environment.
 - ◆ Dry packaging products, the guarantee period should be from 6 months from the date of packing seal.
 - ◆ Sealed packaging is equipped with humidity indicator card, as shown in Figure 5-2.
- Humidity indicator CARDS and baking several ways as follows:



Figure 5-2 Temperature and humidity indicator CARDS

- When opened, if the temperature and humidity indicator CARDS read 10%, 20%, 30%, 40% three color ring are blue, to continue to bake for 2 hours for module;
- When opened, if the humidity indicator CARDS read 10% color ring into pink, need to continue to bake module 4 hours;
- When opened, if the humidity indicator CARDS read into 10%, 20%, color ring into pink, need to continue to bake for 6 hours module;
- When opened, if the humidity indicator CARDS read into 10%, 20%, 30% are pink color ring, need to continue to bake for 12 hours module;
- When opened, if the humidity indicator CARDS read into 10%, 20%, 30%, 40% are pink color ring, need to continue to bake for 14 hours module;
- Baking parameters are as follows:
 - ◆ Baking temperature: $125^{\circ}\text{C} \pm 5^{\circ}\text{C}$;
 - ◆ Set the alarm temperature as 130°C ;
 - ◆ Under the condition of natural cooling $< 36^{\circ}\text{C}$, SMT placement can be made;
 - ◆ Dry times: 1 times;
- If opened the time more than 3 months, please ban the use of SMT process welding this batch module, zedoary because PCB process, more than 3 months bonding pad oxidation, SMT is likely to cause virtual welding, welding, the resulting problems we do not assume corresponding responsibility.
- Please to ESD (static discharge, static electricity discharge) protection module before SMT;
- Please according to the SMT reflow soldering curve, peak temperature 245°C , reflow soldering,

temperature curve as shown in figure 14, section 7.6;

- For the first time in order to ensure the qualified rate of reflow soldering, first SMT please extraction 10% product to visual analysis, AOI inspection, to ensure that the furnace temperature control, device adsorption method, the rationality of the put way; Suggestions : when batch production per hour 5- 10 pieces of visual analysis, AOI test;

C. The matters needing attention

- In the entire production, Each station of the operator must wear anti-static gloves;
- When baking, no more than baking time;
- When roasting, it is forbidden to join explosive, flammable, corrosive substances;
- When baking, high temperature module application tray in the oven, keep the air circulation between each module, at the same time avoid direct contact with the oven wall module;
- Baking, please will bake the door is closed, the guarantee baking box sealing, prevent leakage, temperature influence the baking effect;
- Don't open the door, as far as possible when baking box running if must open, shortening the time of can open the door as far as possible;
- After baking, must be natural cooling modules to $< 36^{\circ}\text{C}$ before wear anti-static gloves out, so as not to burn.
- Operation, forbidden module bottom touch water or dirt;
- Temperature and humidity control level for Level3, storage and baking conditions based on IPC/JEDEC J- STD - 020.

5.3 MSL/Storage Condition

Moisture Sensitivity level 3

1. Calculated shelf life in sealed bag is 12 months at $<40^{\circ}\text{C}$ and $< 90\%$ relative humidity(RH);
2. Peak Package body temperature: 260°C ;
3. After bag is opened, devices that will be subjected to reflow solder or other high temperature process must:
Mounted within: 168 hours of factory conditions $< 30^{\circ}\text{C}/60\%$ RH, or stored at $<10\%$ RH;
If both of these conditions are not met, baking is required before mounting;
4. Devices require bake, before mounting if:
 - a) Humidity indicator card is $>10\%$ when read at $23 \pm 5^{\circ}\text{C}$
 - b) 3a or 3b not met.
5. If baking is required, devices may be baked for 48 hours at $125 \pm 5^{\circ}\text{C}$

5.4 Recommended Reflow Profile

1. Ramp Up

Temp: $<150^{\circ}\text{C}$, Time: 60~90s, Ramp up degree $1\sim 3^{\circ}\text{C}/\text{S}$;

2. Pre-Heat

Temp: $150^{\circ}\text{C}\sim 200^{\circ}\text{C}$, time: 60-120s, Ramp up degree $0.3\sim 0.8^{\circ}\text{C}/\text{S}$;

3. Curing

Peak temp 235°C~250°C (Max <245°C) , time 30-70s;

4. Cooling down

Temp: 217°C~170°C, Ramp up degree 3~5°C/S;

Recommended reflow profile:

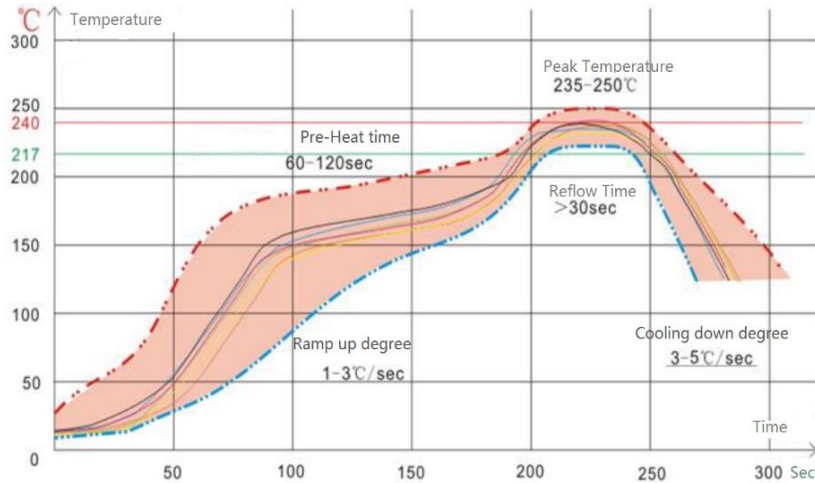

6. Recommended footprint

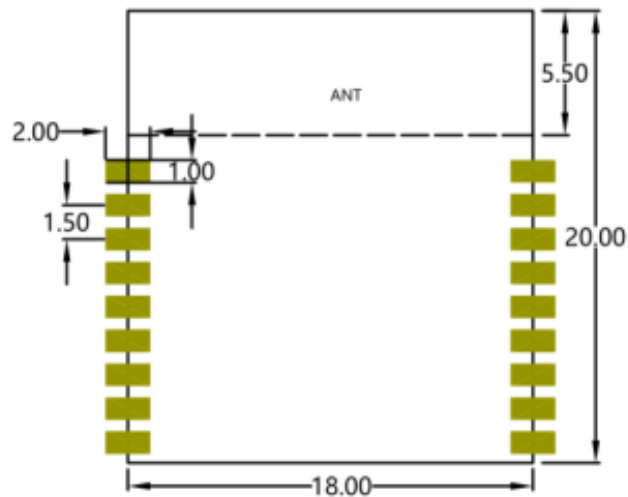
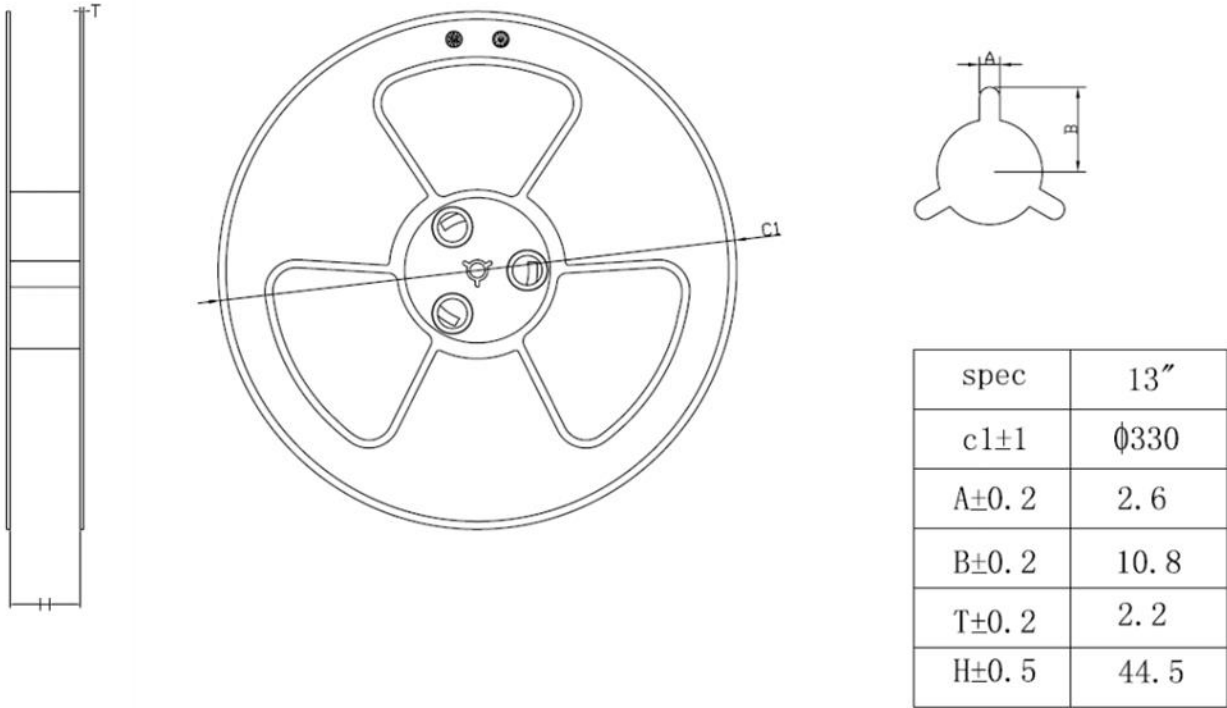

Figure 6-1 Recommended footprint ; (unit: mm)

8. Package information

Production modules are delivered in reel, 500 modules in each reel.



All dimensions in mm unless otherwise indicated.