

# NPC-1210 Series

## Medium/Low Pressure Sensors

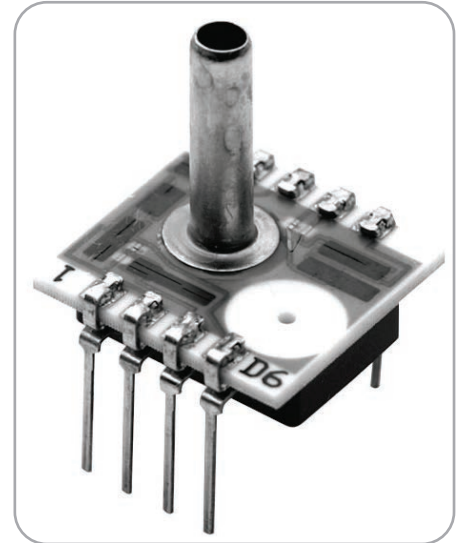

### Features

- High sensitivity
- High accuracy
- Interchangeable
- Temperature compensated 0°C to 60°C (32°F to 140°F)
- PCB mountable package
- DIP package
- Solid-state reliability
- Individual device traceability

### Applications

- Industrial automation
- Air flow monitors
- Process control
- Medical equipment
- Underground cable leak detection
- Ventilation
- Respirator monitoring

# NPC-1210 Series Specifications

## Description

The NPC-1210 series of solid-state pressure sensors is designed to provide a cost-effective solution for applications that require calibrated performance over a wide temperature range. Packaged in a dual-in-line configuration, the NPC-1210 Series is intended for printed circuit board mounting. Optional pressure port and lead configurations provide superior flexibility in low profile applications where pressure connection orientation is critical.

The NPC-1210 Series is based on NovaSensor's advanced SenStable® piezoresistive sensing technology. Silicon micromachining techniques are used to ion implant piezoresistive strain gages into a Wheatstone bridge configuration. The NPC-1210 Series offers the added advantage of superior temperature performance over the temperature compensated range of 0°C to 60°C (32°F to 140°F). A gain set resistor is included to normalize the FSO for field interchangeability.

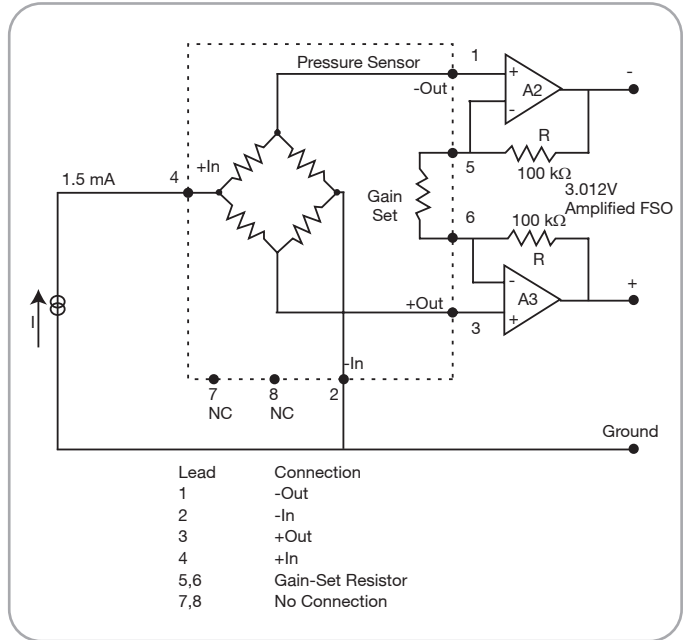

NPC-1210 Series Schematic Diagram

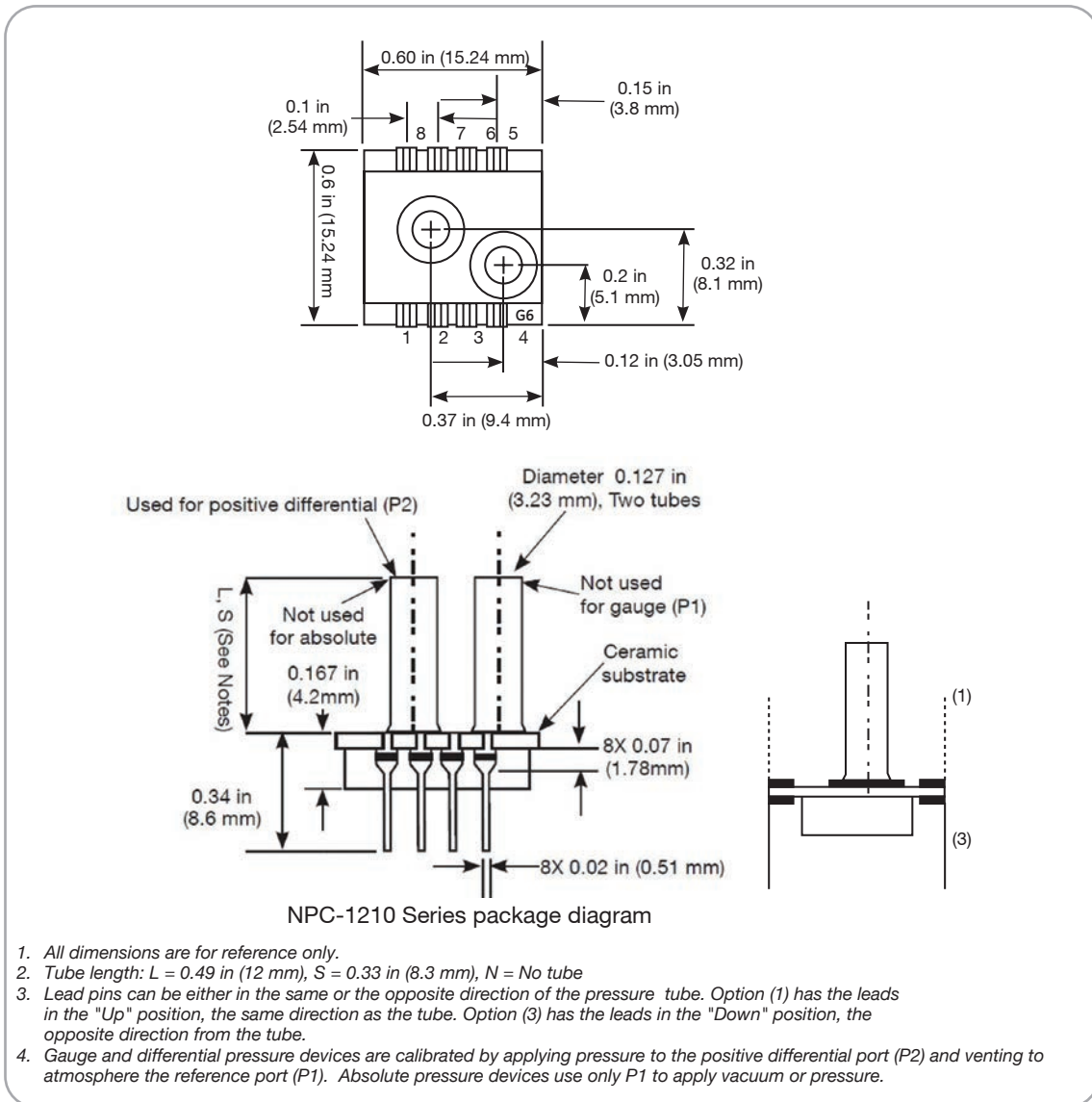

NPC-1210 Series package diagram

# NPC-1210 Series Specifications

## Medium Pressure Sensors

### Pressure Ranges

- Gauge and Differential:
  - 5 psi (34 kPa, 0.34 bar)
  - 15 psi (100 kPa, 1.0 bar)
  - 30 psi (210 kPa, 2.1 bar)
  - 50 psi (340 kPa, 3.4 bar)
  - 100 psi (690 kPa, 6.9 bar)
- Absolute:
  - 15 psi (100 kPa, 1.0 bar)
  - 30 psi (210 kPa, 2.1 bar)
  - 50 psi (340 kPa, 3.4 bar)
  - 100 psi (690 kPa, 6.9 bar)
- For other pressure ranges, please contact NovaSensor.

Parameter	Value	Units	Notes
<b>Environmental</b>			
Temperature Range			
<i>Operating</i>	-40 to 125	°C	(-40° to 257°F)
<i>Compensated</i>	0 to 60	°C	(32°F to 140°F)
<i>Storage</i>	-55 to 150	°C	(-67 to 302 °F)

<b>Mechanical</b>			
Weight	2.5	g	(0.005 lb)
Media Compatibility	Compatible with exposed materials		7
<i>Positive differential and gauge ports</i>	<i>Dry gases only</i>		
<i>Absolute, negative differential ports</i>	<i>Dry gases only</i>		

Parameter	Units	Minimum	Typical	Maximum	Notes
<b>Performance Parameters *</b>					
FS Output (FSO)	mV	75	100	150	2, 3
Zero Pressure Output	mV	-2	—	2	3
Linearity	%FSO	-0.1	—	0.1	4, 8
Pressure Hysteresis	%FSO	-0.1	—	0.1	
Input Impedance	Ω	2500	4000	6000	
Output Impedance	Ω	4000	5000	6000	
Thermal Accuracy–Span	%FSO	-0.5	—	0.5	3, 5, 8
Thermal Accuracy–Zero	%FSO	-0.5	—	0.5	3, 5, 8
Temperature Coefficient–Resistance	%/°C	—	0.2	—	5
Thermal Hysteresis–Zero	%FSO	—	0.1	—	5
Input Excitation	mA	—	1.5	2.0	
Pressure Overload	Rated	—	—	3X	6

## Low Pressure Sensors

### Pressure Ranges

- Gauge and Differential:
  - 10 in H<sub>2</sub>O (2.5 kPa, 0.025 bar)
  - 1 psi (6.9 kPa, 0.069 bar)

Parameter	Value	Units	Notes
<b>Environmental</b>			
Temperature Range			
<i>Operating</i>	-40 to 125	°C	(-40° to 257°F)
<i>Compensated</i>	0 to 60	°C	(32°F to 140°F)
<i>Storage</i>	-55 to 150	°C	(-67 to 302 °F)

<b>Mechanical</b>			
Weight	2.5	g	(0.005 lb)
Media Compatibility	Compatible with exposed materials		7
<i>Positive differential and gauge ports</i>	<i>Dry gases only</i>		
<i>Absolute, negative differential ports</i>	<i>Dry gases only</i>		

Parameter	Units	Minimum	Typical	Maximum	Notes
<b>Performance Parameters *</b>					
FSO 10 inH <sub>2</sub> O	mV	25	50	70	2, 3
FSO 1 psi	mV	50	75	110	2, 3
Zero Pressure Output	mV	-2	—	2	3
Linearity	%FSO	-0.5	—	0.5	4
Pressure Hysteresis	%FSO	-0.1	—	0.1	
Input Impedance	Ω	2500	4000	6000	
Output Impedance	Ω	4000	5000	6000	
Thermal Accuracy–Span	%FSO	-1.0	—	1.0	3, 5
Thermal Accuracy–Zero	%FSO	-1.25	—	1.25	3, 5
Temperature Coefficient–Resistance	%/°C	—	0.22	—	5
Thermal Hysteresis–Zero	%FSO	—	0.1	—	5
Input Excitation	mA	—	1.5	2.0	
Pressure Overload	psi (bar)	5 (0.34)	—	—	—

- \* 1. Supply current = 1.5 mA and ambient temperature = 77°F (25°C), unless otherwise noted. Gauge and differential pressure devices are calibrated by applying pressure to the positive differential port (P2) and venting to atmosphere the reference port (P1).
2. Output span of unamplified sensor.
3. Compensation resistors are an integral part of the sensor package; no additional external resistors are required. Pins 7 and 8 must be kept open. The NPC-1210 is interchangeable only when used with the gain set resistor shown in the schematic diagram. Maximum gain-set resistor mismatch is 2%.
4. Best fit straight line.
5. Temperature range 32°F to 140°F (0°C to 60°C), reference to 77°F (25°C).
6. 3X or 200 psi (13.78 bar) maximum, whichever is less.
7. Exposed materials are pyrex, ceramic, silicon, epoxy, RTV, and stainless steel.
8. 5 psi (0.34 bar) spec.: Linearity: 0.25 ±%FSO, TC-span: 0.75 ±%FSO, TC-zero: 0.75 ±%FSO. otherwise noted.

# NPC-1210 Series Specifications

## Ordering Information

The code number to be ordered may be specified as follows:

### NPC-1210 (Medium Pressure)

↓	Code 005 015 030 050 100	Pressure Range 5 psi (0.3 bar) 15 psi (1 bar) 30 psi (2 bar) 50 psi (3.4 bar) 100 psi (7 bar)	Code D A G	Type Differential Absolute Gauge	Code 1 3	Lead Configurations Up Down	Code L S N	Tube Options Long Short None *
---	---	--	---------------------	---	----------------	-----------------------------------	---------------------	---

NPC-1210 - \_ - \_ - \_ - \_ Typical model number

\* Order NPC-1210-XXXG-XN in place of NPC-1210-XXXD-XN

The code number to be ordered may be specified as follows:

### NPC-1210 (Low Pressure)

↓	Code 10W 001	Pressure Range 10 in H <sub>2</sub> O (25 mbar) 1 psi (69 mbar)	Code D G	Type Differential Gauge	Code 1 3	Lead Configurations Up Down	Code L S	Tube Options Long Short
---	--------------------	---	----------------	-------------------------------	----------------	-----------------------------------	----------------	-------------------------------

NPC-1210 - \_ - \_ - \_ Typical model number

## Warranty

Amphenol Advanced Sensors warrants its products against defects in material and workmanship for 12 months from the date of shipment. Products not subjected to misuse will be repaired or replaced. Amphenol Advanced Sensors reserves the right to make changes without further notice to any products herein. NovaSensor makes no warranty, representation or guarantee regarding the suitability of its products for any particular application, nor does Amphenol Advanced Sensors assume any liability arising out of the application or use of any product or circuit and specifically disclaims and all liability without limitation consequential or incidental damages. The foregoing warranties are exclusive and in lieu of all other warranties, whether written, oral, implied or statutory. No implied statutory warranty of merchantability or fitness for particular purpose shall apply.