

iW Series

2.54mm (0.100") Pitch — Vertical & Right Angle



Plated Thru-Hole (PTH) Connectors

The iW Series connector family is a 2-row high reliability connector solution with a pitch of 2.54 millimeters (0.100"). Available with 10 to 30 contacts and rated up to 5A per contact make it versatile for either signal or power applications. The connectors can also be customized to address unique design requirements.

- Current rating up to 5A per contact
- High vibration and shock resistant
- Withstands extreme temperatures of -65°C to +125°C
- Vertical & right-angle options
- Selectively plated, cost efficient for Industrial applications
- Highly reliable connection for demanding applications

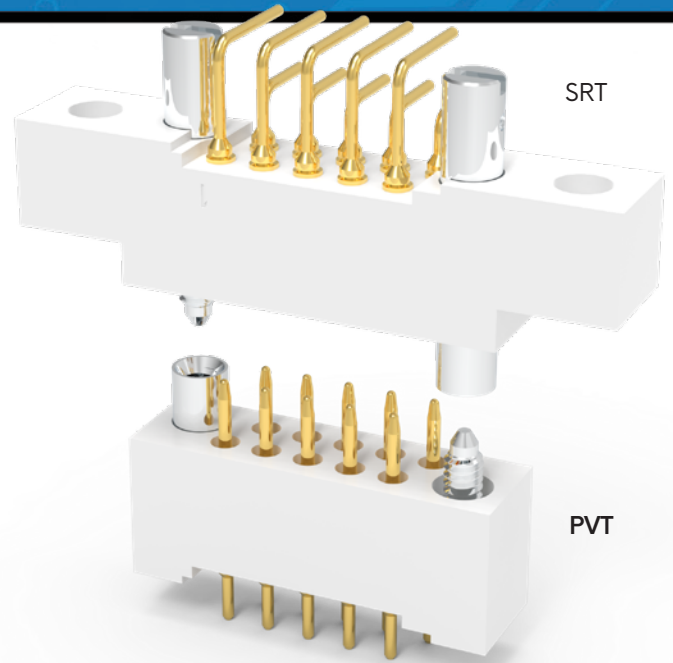

Part Number Builder

iW	2	Body Style	Mounting Ears	Size	Termination	Hardware Style
Series	Rows	P Plug	0 Without	10	PVT7 Pin: Vertical	J Fixed Jacket
		R Receptacle	1 With	14	PVT9 Pin: Vertical	JTA Turning Jacket
				20	SVT7 Socket: Vertical	
				24	SVT9 Socket: Vertical	
				26		
				30		
					SRT7 (J Hardware Only) Socket: Right Angle	
					SRT9 (J Hardware Only) Socket: Right Angle	

Technical Information

Material Specifications

Insulator Material:
Glass-filled PPS (polyphenylene sulfide)

Insulator Color: White

Material (Contacts): Pins: copper alloy
Sockets: beryllium copper

Terminal Material: Copper alloy

Plating (Contacts):
Minimum 15 µin Au over 30 µin Ni

Hardware: Stainless steel

Electromechanical Performance

Rated Current: 5A per contact

Durability: ≥ 250 mating cycles

Test Voltage: 1,000 V AC for 1 minute

Insulation Resistance: 5 GΩ min.

Contact Resistance: 5 mΩ max.

Insertion Force (Max): 4 oz. (1.1N) per contact

Withdrawal Force (Min.):
0.5 oz. (0.14N) per contact

Environmental Specifications

Operating Temperature: -65° to +125°C

Vibration: 10Hz to 2,000Hz, 1.52mm, 147.1m/s² (15G), duration 12h

RoHS: Compliant

iSeries
BASED ON MIL-SPEC. BUILT FOR INDUSTRIAL.

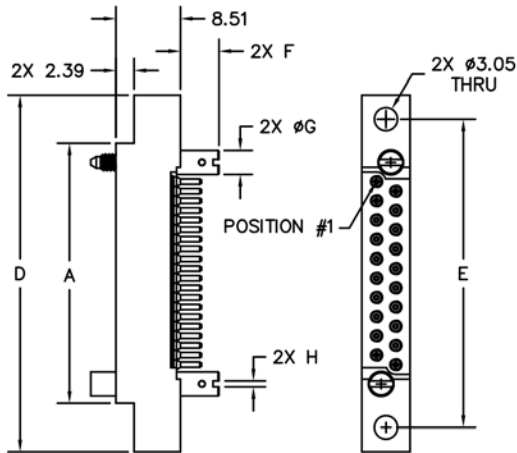

RECEPTACLE (WITH EARS)
(IW-2R1-20-SVT7-JTA)

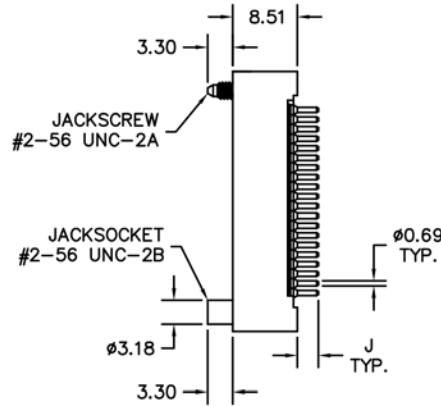

RECEPTACLE (WITHOUT EARS)
(IW-2R0-20-SVT7-J)

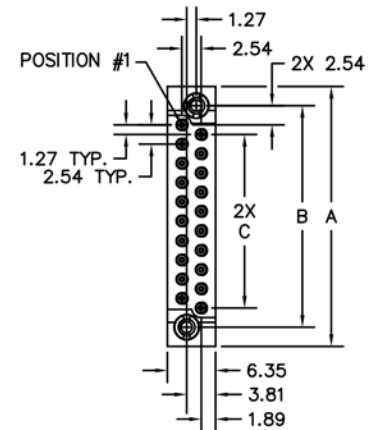

SIZE	DIMENSIONS				
	A	B	C	D	E
10	21.59	16.51	10.16	34.29	27.94
14	26.67	21.59	15.24	39.37	33.02
20	34.29	29.21	22.86	46.99	40.64
24	39.37	34.29	27.94	52.07	45.72
26	41.91	36.83	30.48	54.61	48.26
30	46.99	41.91	35.56	59.69	53.34

HARDWARE	DIMENSIONS		
	F	ØG	H
-J	N/A	N/A	N/A
-JTA	5.08	Ø3.18	SLOT 0.79 x 0.79

CONTACT	DIMENSIONS
	J
-SVT7	2.77
-SVT9	3.56

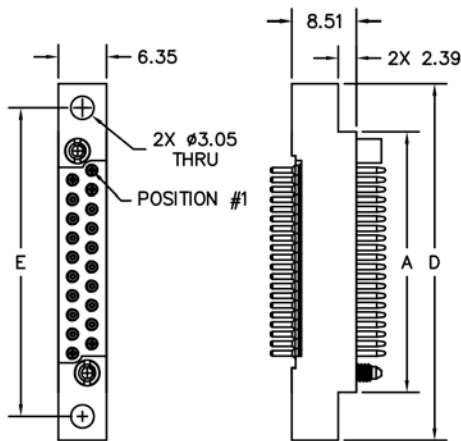

PLUG (WITH EARS)
(IW-2P1-20-PVT7-J)

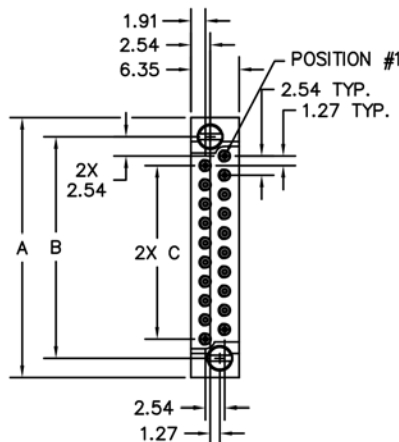

PLUG (WITHOUT EARS)
(IW-2P0-20-PVT7-JTA)

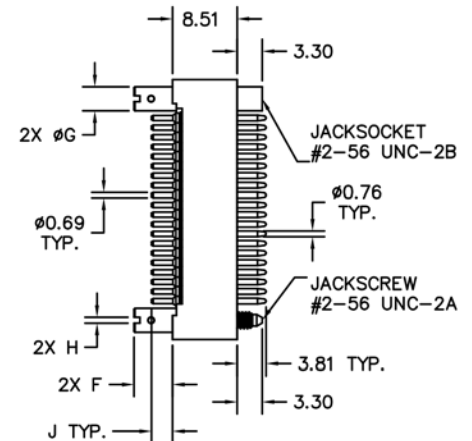

SIZE	DIMENSIONS				
	A	B	C	D	E
10	21.59	16.51	10.16	34.29	27.94
14	26.67	21.59	15.24	39.37	33.02
20	34.29	29.21	22.86	46.99	40.64
24	39.37	34.29	27.94	52.07	45.72
26	41.91	36.83	30.48	54.61	48.26
30	46.99	41.91	35.56	59.69	53.34

HARDWARE	DIMENSIONS		
	F	ØG	H
-J	N/A	N/A	N/A
-JTA	5.08	Ø3.18	SLOT 0.79 X 0.79

CONTACT	DIMENSIONS
	J
-PVT7	2.77
-PVT9	3.56

All dimensions in millimeters.