

Considerations When Designing a Wireless Charging System

Wireless charging is expected to grow from 500 million units in 2017 to 750 million units in 2018; consumer electronic devices lead this 33% increase back in 2015 and accelerated with the iPhone 8 and iPhone X releases thanks to the built-in wireless charging.

Figure (1) – Wireless Power Market Forecast

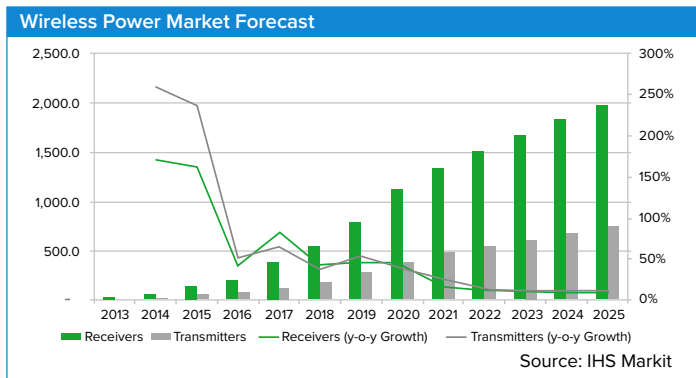

This growth has also been the catalyst for ancillary product designs that now incorporate wireless charging. For many designers, this is their first exposure to a wireless charging design.

The wireless charging technology often leads to several questions:

- Which wireless charging coil technology should I choose?
- What size coil should I use?
- How do I match transmitter and receiver coils for optimal efficiency?
- What power and efficiency could I expect from my design?
- What type of receiver coils can I use in my design?

Choosing the right wireless charging coil technology

The wireless charging market was until recently split into two standard bodies Wireless Power Consortium (WPC) and Power Matters Alliance (PMA), but this has now seen convergence into one company. CES 2018 showed a tidal wave of Qi(*) charging pods dominating the wireless

charging market. PowerMat, which created the alternative standards body PWA, has now joined forces with the WPC to focus on Qi systems.

(*) Qi (pronounced Chee, is the wireless charging standard from the Wireless Power Consortium (WPC).

The Qi Wireless Charging Technology

Qi is the Wireless Power Consortium (WPC) standard for close coupled inductive wireless charging, and involves coupling EMF from a transmitter coil with a closely coupled Rx coil placed over the top of it.

Figure (2) - Inductive Charging vs. Resonant Charging

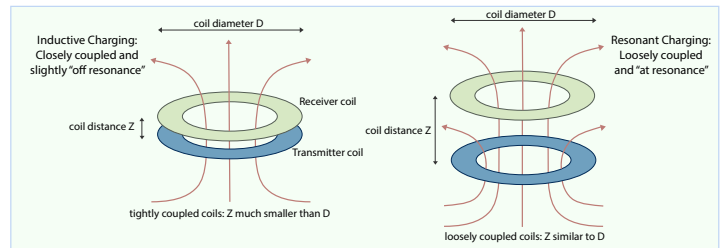

Tightly coupled, o -resonance coils (left) allow for maximum power transfer, while loose, resonant coils (right) can be placed anywhere in the field. Figure 2 shows the basic differences between the two technologies.

Qi technology, as mentioned, is seeing new heights of growth and is now mainstream with silicon suppliers and product developers; but charging at a distance is still the Holy Grail of wireless charging.

Resonant charging is the other alternative offering loosely coupled charging so items being charged have more freedom. Many advantages can be harnessed from resonant wireless charging technology. For example, allowing multiple devices to be charged simultaneously, offering different charging ranges for applications and allowing control over which devices are charged first.

While charging efficiency of resonant charging will be less than the close coupled version, different user applications can still benefit, offering innovative solutions. Examples such as charging interactive customer displays in supermarkets or background charging of devices in your living room can be enabled by this approach. Resonant charging isn't the cheapest or most efficient, but both technologies will find their niche driven by the end application.

Wireless Charging Technology Comparisons

As we have already shown, Qi (closely coupled inductive charging) is the dominant technology, but the best wireless charging technology will be decided by application factors.

Inductive Charging	Resonant Charging
<ul style="list-style-type: none"> Tightly coupled means much greater efficiency, but less spatial freedom. Can only charge a single mobile device. If used the alignment magnet reduces "k" (coupling factor) as well as inductance and lowers efficiency. High power transfers possible for example: Semtech TSDMRX-19V20W-EVM (19V/20W), using Abracon AWCCA-RX350300-101 Rx coil. Faster charge rates than resonant charging relative to the size of the coil. 	<ul style="list-style-type: none"> Looser Coupled << efficiency, but greater spatial freedom. Can charge multiple mobile devices and does not need alignment aids. Lower power transfer (8W / 1.6A), example IDT P9038 5V Resonant Power Transmitter. The new high power near field WattUp transmitter capable of 10W charging. Minimum distance at which both coils can maintain resonant operation. If the resonating coils are moved too close, their mutual inductance causes the oscillating magnetic fields to "collapse" and power transfer ceases. Coils tend to be larger to provide the power transfer and have the Q needed. Higher Q demands low impedance, also driving thicker lower resistive wire.

Efficiency

This is the most important measurement parameter to decide which wireless charging technology is best suited for a particular application. Measurement of efficiency of any charging system, including wireless charging systems, can be computed from the basic efficiency formula: $Efficiency = P_{out} / (P_{out} + P_{loss})$, but when these measurements are made, it is important to understand the total system efficiency.

Figures 3 and 4 compare wired charging to resonant charging, showing how efficiency varies where the DC Out is measured.

Wired versus inductive close coupled wireless charging:

Figure (3) – Typical Wall Wired Charging System

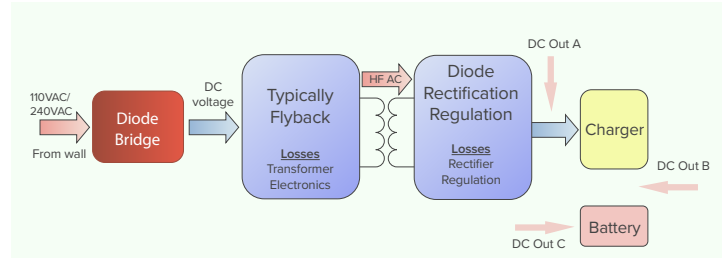

Efficiency at different points in the wall charging system:

- At (DC Out A) – output of wireless power receiver efficiency ~80% to 90%
- At (DC Out B) – output of wireless power receiver efficiency ~ 60% to 76%
- At (DC Out C) – output of wireless power receiver efficiency ~ 50% to 64%

When the efficiency of the wire (~95%) is included, the system efficiency can be ~72% to the charger and as low as 47% to the battery

Figure (4) - Typical Wireless Charging system

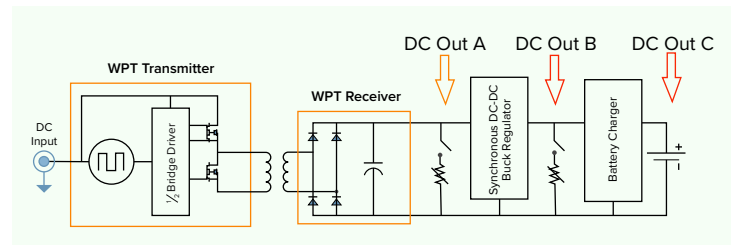

Efficiency at different points in the wireless charging system:

- At (DC Out A) – output of wireless power receiver efficiency ~89%
- At (DC Out B) – output of wireless power receiver efficiency ~75%
- At (DC Out C) – output of wireless power receiver efficiency ~60%

So it can be shown that inductive charging can be as efficient as a wired charger when measured from end to end of the system.

Inductive close coupled versus resonant wireless charging:

Figure (5) – Inductive and resonant charging efficiency versus load (battery) current

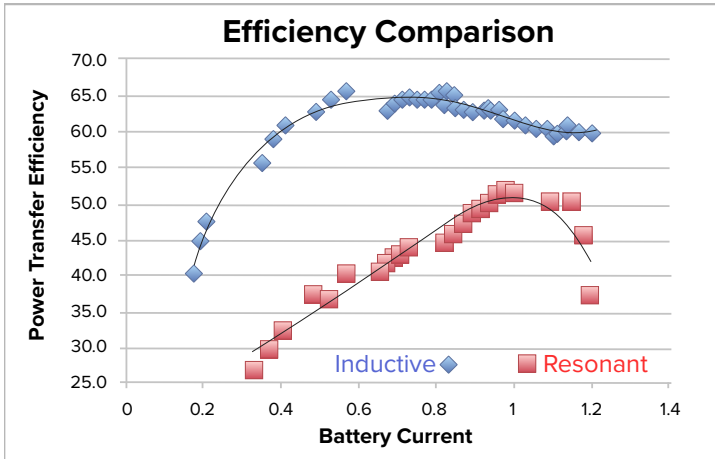

The purpose of the comparison in Figure (5) is to show the trade offs between inductive and resonant charging technologies.

Figure (6) – Charge-cycle efficiency calculation plotting total energy versus time over the battery-charge cycle.

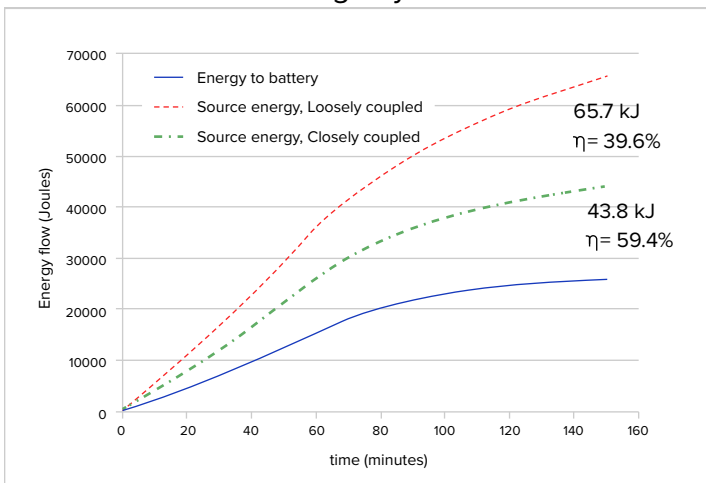

The inductive closely coupled system used 50% less energy than the loosely coupled resonant system over the battery’s 2100mAH charge period. Comparing the two technologies, the high frequency, loosely coupled system will often use GaN output transistors and zero-voltage switching, which results in significant transmitter switching

losses, but due to the nature of resonant charging loosely coupled solutions, even at 20mm, show relatively little coupling loss.

Figure (7) – Power efficiency versus Q and Dynamic Ratio (Dr) between Tx and Rx Coils

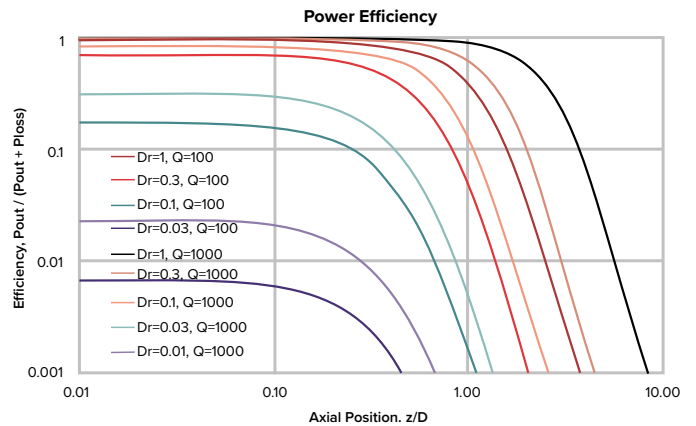
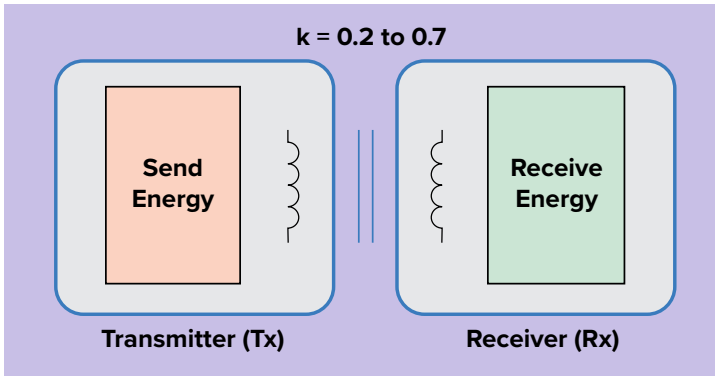

Figure (7) shows some of the limitations of inductive charging, which requires coils to be aligned and well matched. The plots show that power transfer efficiency is a function of the Q of the system and the distance between the power transmitter and power receiver. Some of the data shows Q at 1000, but this is not achievable in practice due to wire or winding losses, so Q’s of 20s to 100 are normal. The tuning of the coils helps to improve Q. These limitations point to the benefits of loosely coupled resonant charging where alignment of coils by design cannot be planar.

Considerations when picking a Rx Coil for Inductive Charging – Coupling Factor

The “transformer” in an inductive, close coupled wireless charging system is two separate interactive devices: a Tx Coil and a Rx Coil. When placed over each other, they couple inductively and are modeled as a 2-coil transformer with an air core.

Figure (8) – Inductive Coil Coupling



The shielding on the Tx and Rx coils is essential and provides a magnetic flux short, allowing the flux fields to be contained within the two cores. See the concentrations of flux lines inside the ferrite sheets of the coils.

Typical coupling factors are much lower ($k=0.2 \sim 0.7$) compared to a traditional transformer ($k=0.95 \sim 0.99$). Some of this weaker coupling can be mitigated by the series resonant cap on the Tx and Rx coils that increases Q. This means the efficiency is limited to about 85%.

Coupling factor (k) -

$$k = \frac{L_{12}}{\sqrt{L_{11} L_{22}}}$$

Considerations when picking a Rx Coil for Inductive Charging – The Shield

Inductive wireless charging coils will normally be seen with a ferrite shield. Figure (10) shows the coil positioned on the black ferrite shield. The ferrite has important properties that shield electronics behind the assembly.

The shield has 2 major functions:

- Provide a “short path” for the magnetic flux so that it limits the heating of other components behind the shield, focusing EMF into the ferrite.
 - Improve inductance so that coils can be wound with less windings, saving excessive resistance.
- Note: the shield should extend beyond the outer edge of the coil to reduce EMF from escaping and reduce the saturation point.

Figure (10)

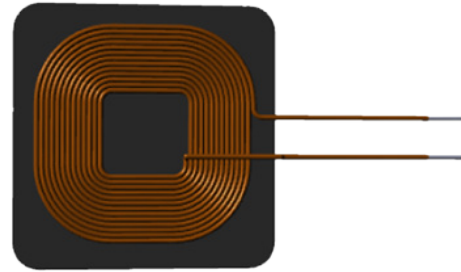

The ferrite material used is important. Soft ferrite is preferred. Ferrites can be divided into two families based on their magnetic coercivity (their resistance to being demagnetized). Soft ferrites have low coercivity and are best for shielding.

The ferrite thickness is an important consideration; thicker shields absorb more flux and are less susceptible to saturation (B_s), so the thickness and O/D around the outside of the coil is an important consideration.

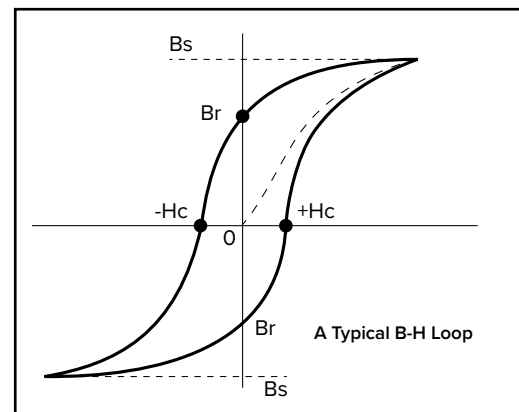

Saturation magnetization (B_s) represents the saturation limit of flux density, and Remanence (B_r) is the residual flux even after the withdrawal of the inducing field. Coercivity (H_c) is the magnetic field required in the opposite direction to demagnetize the ferrite.

Considerations when picking a Rx Coil for Inductive Charging – The Coil Wire

Factors affecting the wire type:

Cost – Often in Rx coils, rather than Tx coils, the wire type and gauge are determined by cost.

Larger diameter and bifilar wire offer lower DC resistance and less loss but are more costly.

Litz wire is often used to reduce the impedance at the switching frequency (~125KHz). It does this by reducing Skin Affect.

Skin Affect depth at 125KHz for copper is 184µm, so the bundled wires have less loss and more of the copper is used to pass the current.

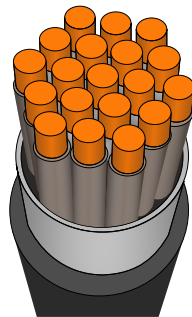

Litz Wire

The twisting also evens out EMF along the length, so reducing Proximity affect and eddy currents result in further loss. This is why designers should check the Rac, as well as, the Rdc of the coil.

Higher power Rx coils like the Abracon AWCCA-RX350300-101 have a Rdc of 150mΩ and Q of 90, which offers low loss and contributes to the high efficiency of the Semtech 20W Rx system.

Shielding should extend a minimum of 2.5mm beyond the edge of the outer winding to allow the flux to flow and not saturate or spill over into other electronics.

Considerations when picking a Rx Coil for Inductive - Number of turns and Inductance:

With wire and shield chosen, the number of turns determines the inductance and available power.

Coil Inductance

$$N_e = \frac{1}{k} \sqrt{\frac{L_{22}}{L_{11}}}$$

&

Coupling Factor

$$k = \frac{L_{12}}{\sqrt{L_{11} L_{22}}}$$

determine

Voltage Gain

$$\frac{V_2}{V_1} \propto k \sqrt{\frac{L_{22}}{L_{11}}}$$

and available power.

The area of the Rx coil should be equal to or within 80% of the Tx coil. This should provide a suitable coupling coefficient of >50% with a distance between Tx and Rx coils of 2.5 ~ 5mm as specified by WPC.

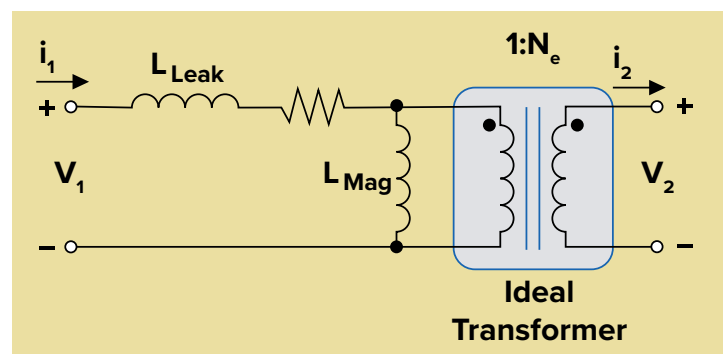

Coil Dimensions	TURNS	Vout (V)	Pout (W)	L22 (uH)	k
48 x 22mm	15	5	5	12	"0.6
28 x 14mm	24	5	2.5	33	"0.25
35 x 35mm	24	7	5	22	"0.5

Coil Dimension Example

If a 5V / 5W output is desired, a coupling coefficient of around 0.5 with a Rx coil inductance of 10uH is sufficient to produce the voltages needed.

Consider...

$$V_2 \propto kV_{IN} \sqrt{\frac{L_{22}}{L_{11}}} \quad \& \quad L_{22} \propto N_2^2$$

Coil inductance is proportional to number of turns squared.

Summary:

There are multiple factors to consider when selecting coils for use in wireless charging applications. Achieving the appropriate power transfer, efficiency, and performance while meeting the size and form-factor requirements can be a challenge. With the right coil and an understanding of the necessary trade offs, a wireless charging design can be optimized.

Designers are encouraged to leverage Abracon's wide product offering and in-house expertise to arrive at the best possible wireless charging solution.

Author Information:

Dean Clark
Senior Technical Manager
Abracon, LLC.

TINY BUT MIGHTY BY ABRACON[®] LLC

SOLUTIONS FOR THE IoT'S MOST FOOTPRINT CHALLENGED APPLICATIONS



Miniature 32kHz XO
ASAKMP
1.6 x 1.2mm footprint
0.6mm profile

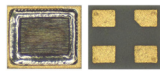

Miniature XTAL
ABM13W
1.2 x 1.0mm footprint
0.33mm profile

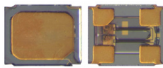

Miniature 32kHz XTAL
ABS04W
1.2 x 1.0mm footprint
0.35mm profile

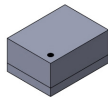

Power Optimized MEMS XO
AMJM/AMPM/AMJD/AMPD
1.6 x 1.2mm footprint
Low 0.85mm profile



MEMS 32kHz Oscillator
ASTMTXK
1.54 x 0.84mm footprint
0.6mm profile



GPS/GLONASS/BEIDOU
Chip Antenna
ACAR0301-SG3
3.05 x 1.6mm footprint
0.55mm profile

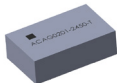

Chip Antenna
ACAG0201-2450-T
2.0 x 1.25mm footprint
0.6mm profile



Chip Inductor
ASMPL
1.6 x 0.8mm footprint
0.5mm profile



Wireless Charging Coils
AWCCA-12R12H11-C01-B
12 x 12mm footprint
1.1mm profile

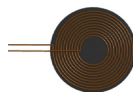

Wireless Charging Coils
AWCCA-15N15H06-C01-B
Ø15.0 footprint
0.6mm profile

LOCATIONS

CORPORATE HEADQUARTERS

5101 Hidden Creek Ln
Spicewood, TX 78669
Ph: 512.371.6159

CALIFORNIA OFFICE

24422 Avenida de la Carlota
Suite 290
Laguna Hills, CA 92653
Ph: 949.546.8000

LOCATED GLOBALLY

BRAZIL | GERMANY | HUNGARY |
INDIA | ISRAEL | MEXICO |
SINGAPORE | SHENZHEN |
TAIWAN | UK

CONTACT

TECHNICAL SUPPORT

Tech-Support@abracon.com

PR AND MEDIA INQUIRIES

PR@abracon.com

GENERAL INQUIRIES

AbInfo@abracon.com

