



The Power of Linking Together

**ABRACON
CORPORATION**

**Abracon PTM
Introduction to AMCA Series
Ceramic Multilayer Chip Antennas**

**Crystals
Oscillators
Filters
Precision Timing
Inductors**



AMCA Series Multilayer Chip Antennas

Purpose

To introduce AMCA Series, Multilayer Chip Antennas.

Objective

Present the advantage, performance and applications of Abracon AMCA Series.

Content

22 pages

Learning Time

25 minutes

Welcome to Abracon's AMCA Series; Ceramic Multilayer Chip Antenna Training Module. This training session will provide an overview of the key features and benefits; as well as, discuss the applications of this product series.

Crystals
Oscillators
Filters
Precision Timing
Inductors





Product - AMCA Series Ceramic Multilayer Chip Antennas

Abracon AMCA Series-Part Numbering

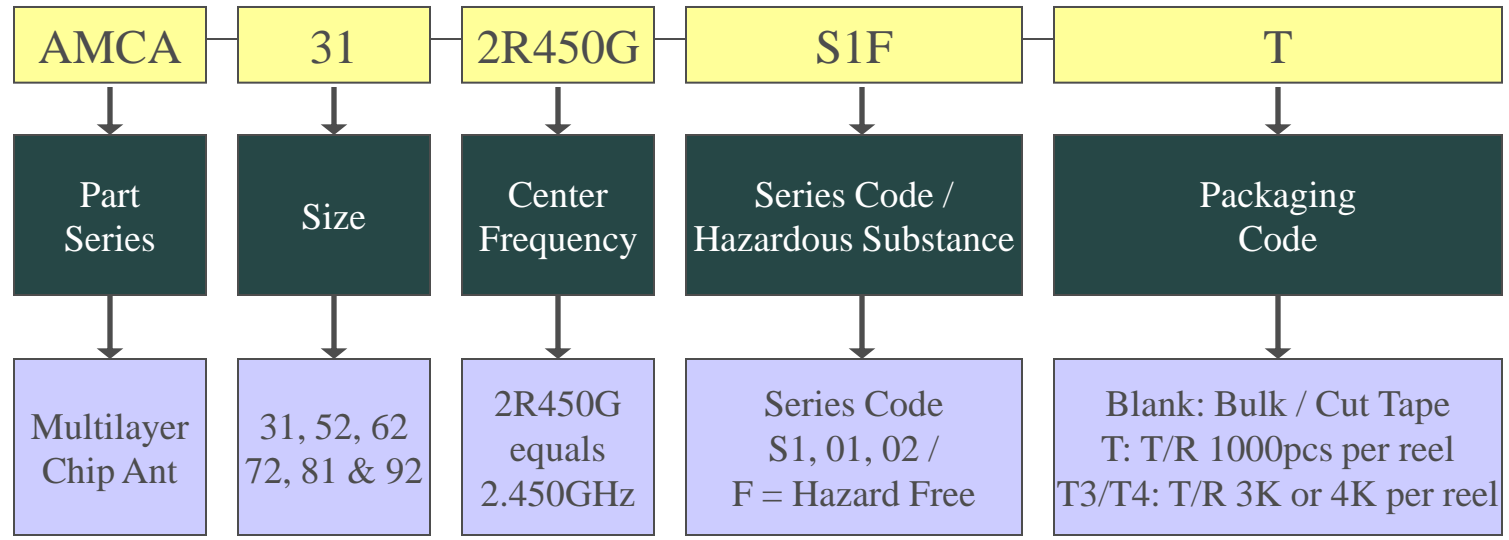
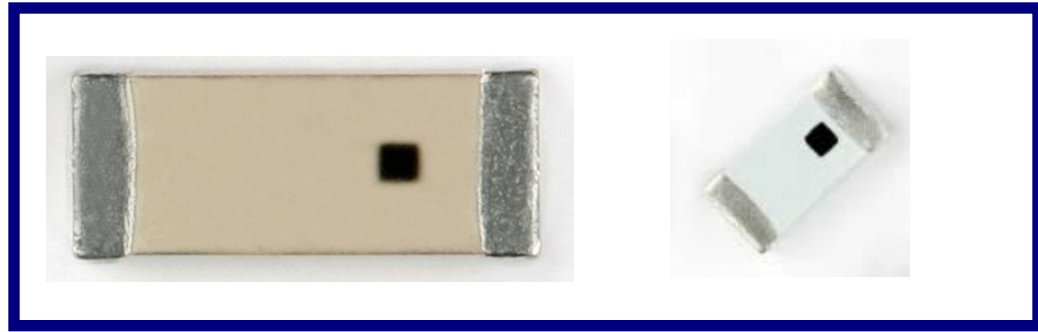

The AMCA Series offers a range of Multilayer Chip Antennas as described by their part number code

Crystals
Oscillators
Filters
Precision Timing
Inductors





Abracon AMCA Series - Part Numbering & Descriptions

Part No	Description / Band	Center Frequency	Size
		Bandwidth (MHz)	
AMCA31-2R450G-S1F-T	Chip Antenna – WLAN / WiFi / Bluetooth	2450MHz 2405 ~ 2495MHz	3.1 x 1.6 x 1.2mm
AMCA31-2R800G-S1F-T	Chip Antenna WLAN	2800MHz 2750~ 2850MHz	3.1 x 1.6 x 1.2mm
AMCA52-2R350G-S1F-T	Chip Antenna WLAN	2350MHz 2275 ~ 2425MHz	5.2 x 2.1 x 1.1mm
AMCA52-2R510G-S1F-T	Chip Antenna WLAN	2510MHz 2410 ~ 2610MHz	5.2 x 2.1 x 1.0mm

The ACMA Series covers a broad range of RF bands including IEEE 802.11b/g & IMT, and WiMax bands. The term IMT (International Mobile Telecommunications) is the root name which encompasses both IMT-2000 and IMTAdvanced (4G) collectively.

**Crystals
Oscillators
Filters
Precision Timing
Inductors**





Abracon AMCA Series - Part Numbering & Descriptions

Part No	Description / Band	Center Frequency	Size
		Bandwidth (MHz)	
AMCA52-2R540G-S1F-T	Chip Antenna WLAN	2540MHz 2440 ~ 2640MHz	5.2 x 2.1 x 1.0mm
AMCA52-2R710G-S1F-T	Chip Antenna WLAN	2710MHz 2610~ 2810MHz	5.2 x 2.1 x 1.0mm
AMCA52-2R780G-S1F-T	Chip Antenna WLAN	2780MHz 2680 ~ 2880MHz	5.2 x 2.1 x 1.0mm
AMCA62-2R640G-01F-T	Chip Antenna WLAN	2640MHz 2540 ~ 2740MHz	6.0 x 2.0 x 1.0mm

IMT 5.384A describes the bands, or portions of the bands, 1710 ~ 1885 MHz, 2 300 ~ 2400 MHz and 2 500 ~ 2 690 MHz. These are identified for use by administrations wishing to implement International Mobile Telecommunications (IMT) in accordance resolution 223 (Rev.WRC-07)
The AMCA series covers the upper two IMT bands.

Crystals
Oscillators
Filters
Precision Timing
Inductors





Abracon AMCA Series - Part Numbering & Descriptions

Part No	Description / Band	Center Frequency	Size
		Bandwidth (MHz)	
AMCA72-2R470G-S1F-T	Chip Antenna WLAN	2470MHz 2370 ~ 2570MHz	7.0 x 2.0 x 1.0mm
AMCA72-2R860G-02F-T	Chip Antenna WLAN	2860MHz 2760~ 2960MHz	7.0 x 2.0 x 1.0mm
AMCA81-3R010G-S1F-T	Chip Antenna WLAN	3010MHz 2910 ~ 3110MHz	8.0 x 1.0 x 1.0mm
AMCA92-2R660G-S1F-T	Chip Antenna WLAN	2660MHz 2410 ~ 2610MHz	9.0 x 2.0 x 1.0mm

The AMCA antennas also covers portions of the WiMax (IEEE-802.16.) bands, that operates globally between 2-11 GHz (3.5 GHz in Europe) for Fixed WiMax and 2-6GHz for Mobile WiMax. They also cover several TDD LTE bands. In both cases the AMCA antenna are applicable for the user equipments.

Crystals
Oscillators
Filters
Precision Timing
Inductors





Example of Block Diagram WiFi / WLAN TCVR

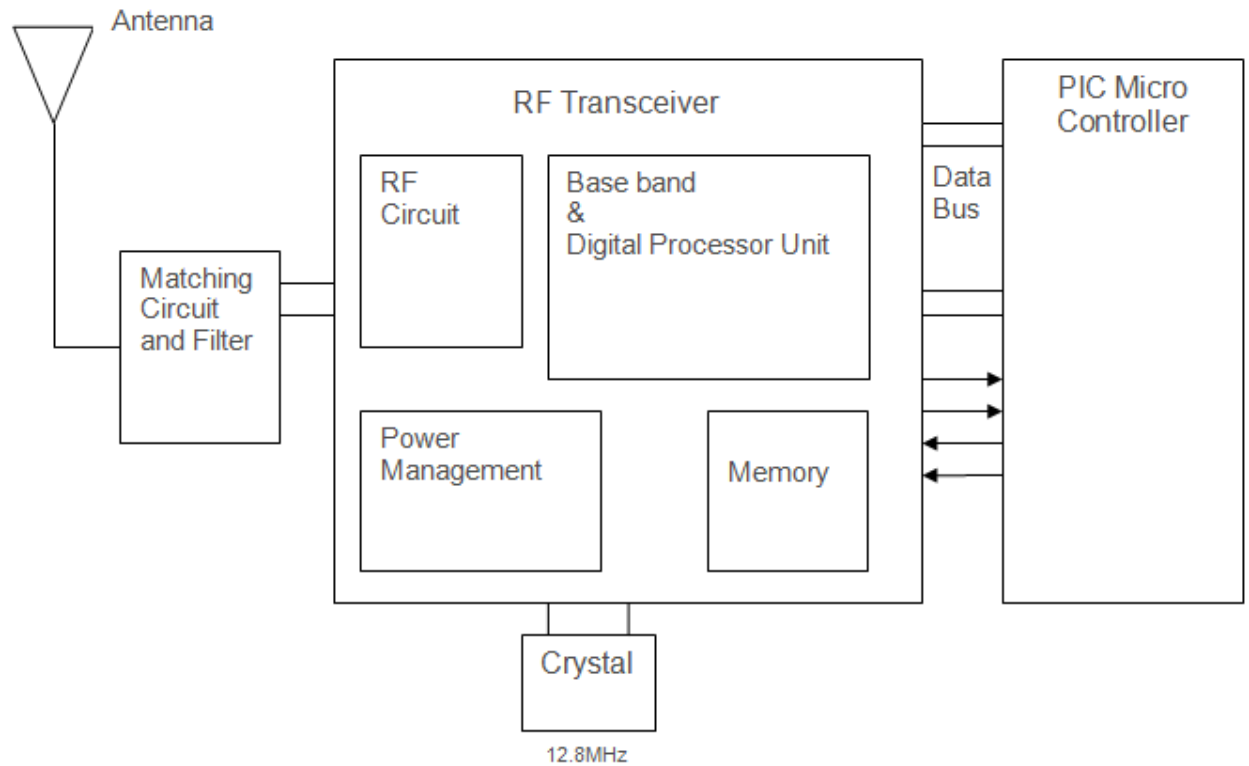

Block diagram shows application of **Chip Antenna** with a RFIC.

In this WiFi or ISM example; the 2.45GHz antenna provides the transmission and reception of signals. In many handheld solution the choice of antenna will be a ceramic chip type. Abracon also provides other BOM elements for example SAW, Balun, BPF, as well as Crystals or Resonators.

Crystals
Oscillators
Filters
Precision Timing
Inductors

ABRACON CORPORATION



Ceramic Multilayer Chip Antenna Technology

What are Chip Antennas?

Chip antennas come in various sizes and are often seen as small ceramic blocks with minimal metal artwork and SM pads into which the signal is launched.

Multilayer Ceramic Technology

The AMCA Series are made from LTCC (Low Temperature Co-fired Ceramic). This technology is the same used in multilayer inductors and capacitors, allowing the devices to be small but especially low profile. The metallization is all within the devices, so only the pads and can be seen at the ends of the package.



Chip Antennas are small ceramic blocks, either solid or multilayer; this type are the latter, and have been manufactured using LTCC technology, so allowing exceptional low profiles. This allows for compact very low profile devices.

Crystals
Oscillators
Filters
Precision Timing
Inductors





Ceramic Multilayer Chip Antenna Technology

Size of Multilayer Chip Antennas

- Antenna size is one of the determining factors to achieve **Gain** and **Bandwidth** requirements that are important for radio system design.
- A reduction of size while maintaining efficiency leads to a reduction in bandwidth; conversely maintaining efficiency and bandwidth leads to a lower gain ⁽¹⁾.

Part Number	Code / Size (mm)	Bandwidth (MHz)	Peak Gain (dBi)
AMCA 31 -2R450G-S1F-T	(31) 3.2 x 1.6 x 1.2	90MHz	+0.5dBi
AMCA 52 -2R350G-S1F-T	(52) 5.2 x 2.1 x 1.0	200MHz	+2.5dBi
AMCA 62 -2R640G-01F-T	(62) 6.0 x 2.0 x 1.0	200MHz	+2.6dBi
AMCA 72 -2R470G-S1F-T	(72) 7.0 x 2.0 x 1.0	200MHz	+2.7dBi
AMCA 81 -3R010G-S1F-T	(81) 8.0 x 1.0 x 1.0	200MHz	+2.0dBi ⁽²⁾
AMCA 92 -2R660G-S1F-T	(92) 9.0 x 2.0 x 1.0	200MHz	+3.0dBi

(Note ⁽¹⁾: Subject to similar frequency bands and the same dielectric constant)
(Note ⁽²⁾: Lower gain here is subject to higher operating frequency 3.010GHz)

The size of the Chip Antennas is determined by the dielectric constant (Er) of the Ceramic. Designers need to consider trade-offs of board space, gain and bandwidth requirements when picking an antenna.

Crystals
Oscillators
Filters
Precision Timing
Inductors





Key Features of Multilayer Chip Antennas

- o Multilayer Chip Antennas offer...
- o Use of multilayer technology offers compact design.
- o Available across a range of bands, makes these ideal for multi-band applications like Mobile Phone / Tablets / WLAN / WiMax / LTE
- o Multilayer technology provides exception low profile, light weight, range of form factor suitable for compact applications.
- o The range of form factors gives designers scope to exploit excellent gain and directivity performance relative to their size.
- o Ease of matching during application development.
- o Better SAR response than PCB traces .
- o Improved isolation allowing multiple antenna applications.
- o Omni-directional radiation highly suitable for mobile communications.

Multilayer Chip Antennas offer a range of advantages to designers who have restricted space or cannot afford an external antenna. Key features include low profile compact designs, and choice of form factors giving designers flexibility to trade size, efficiency, & gain to meet system requirements while minimizing antenna profile.

Crystals
Oscillators
Filters
Precision Timing
Inductors





Antenna Radiation Patterns

Crystals
Oscillators
Filters
Precision Timing
Inductors



3D Radiation Pattern

2445.000MHz

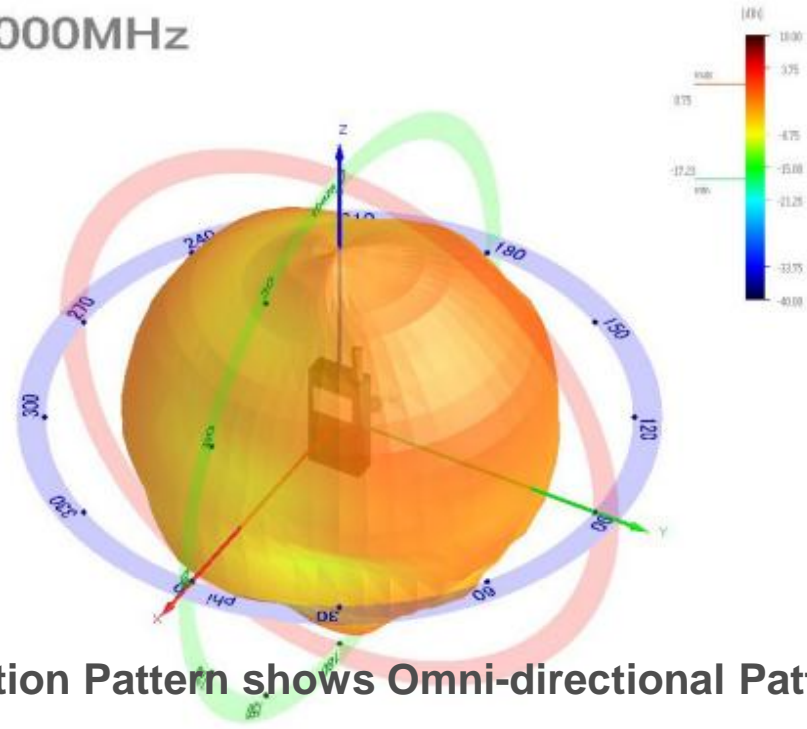

3D Radiation Pattern shows Omni-directional Pattern

No.	Freq.	Pwr Sum	Eff[%]	Avg[dB]	Peak[dB]	θ[deg]	φ[deg]	H(θ-90)	Peak[dB]	φ[deg]	BW[deg]	Avg[dB]	Peak[dB]	θ[deg]	BW[deg]	E1(φ-90)	Peak[dB]	φ[deg]	BW[deg]	E2(φ-90)	Peak[dB]	θ[deg]	BW[deg]	
1	2400.000	32.82	-4.84	-0.42	135.00	195.00	-4.91	-2.19	150.00	130.57	-5.76	-2.53	-135.00	40.19	-4.43	-1.55	30.00	101.04						
2	2425.000	34.77	-4.59	-0.33	135.00	195.00	-4.33	-2.14	210.00	135.20	-5.50	-2.31	-135.00	38.97	-4.20	-1.66	30.00	115.60						
3	2445.000	44.89	-3.48	0.60	135.00	195.00	-3.02	-0.71	210.00	132.38	-4.54	-1.32	-135.00	42.79	-3.18	-0.66	60.00	123.04						
4	2465.000	31.90	-4.96	-1.03	135.00	195.00	-4.41	-1.97	210.00	54.47	-6.02	-2.65	-135.00	46.22	-4.77	-2.21	60.00	118.75						
5	2485.000	30.51	-5.16	-1.28	135.00	195.00	-4.60	-2.17	210.00	47.55	-6.09	-3.03	-135.00	48.37	-5.07	-2.58	60.00	115.82						

The diagram shows the omni-directional 3D radiation patter of a typical Chip Antenna. This provides 360 degree coverage, and is suited to handheld devices.



Typical Antenna PCB Matching

Chip antennas should be matched within the environment of the final product. Normally this process can be done with inductors and / or capacitors.

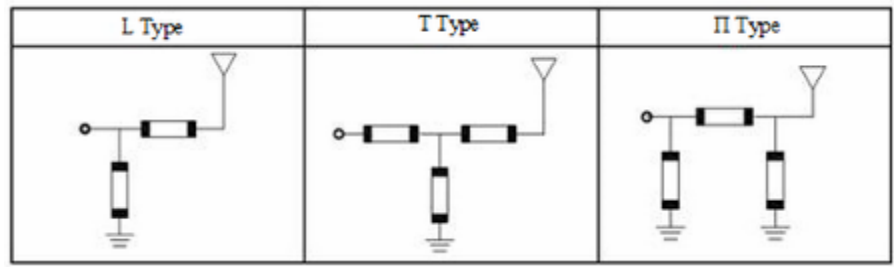
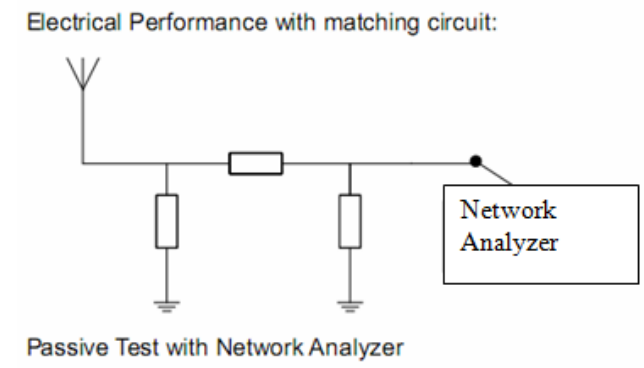
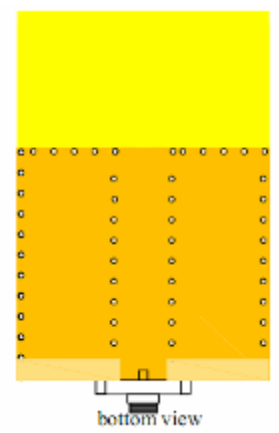
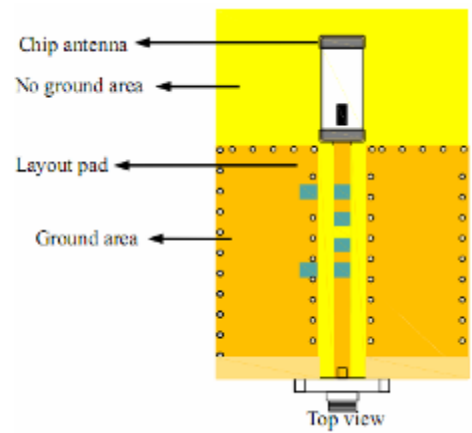

Note: It is recommended to pre-place the π -type circuit layout that offers full flexibility to match the antenna to 50 Ohms, in the final product layout. Depending on matching, NC may apply to certain components in the matching configurations above.

The diagram shows a typical pcb layout for a chip antenna, with matching components. Typically the antenna will need a no-ground region / keep out area. Matching should be done in final production environment. π -type circuit layout should be adopted for flexibility.

Crystals
Oscillators
Filters
Precision Timing
Inductors





Comparison between Dielectric & LTCC Multilayer Chip Antennas

- ABRACON offers both Dielectric and LTCC Multilayer Chip antennas from the **ACA** and **AMCA** series respectively.

Dielectric Chip Antennas: ACA series

- Made from a solid ceramic block onto which silver is printed or sprayed to make an antenna pattern. This might take the form of a meandering line of silver metallization to create a helical type antenna, (see below).
- Process scalable based on block size, suitable for low to high volumes.
- More costly, approximately 50%
- Higher gain for same size block

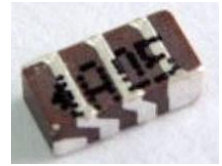

LTCC Chip Antennas: AMCA series

- These are made from several layers of dielectric sheets, that are pressed then fired. The multilayer technique allows metallization on each layer that are joined internally with via holes. So in this process the helical pattern would be contained internally across the layers.
- Lower cost
- Lower gain for same size compared to dielectric types.
- Wide range of size formats, all very low profile.
- Process suited to very high volumes

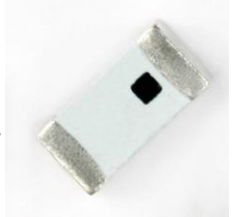

Abraccon offers both Dielectric and LTCC multilayer chip antennas. The dielectric types have higher gains & costs compared to LTCC types, that offer wider range of sizes, very low profiles and lower costs.

Crystals
Oscillators
Filters
Precision Timing
Inductors





What RF Applications need Chip Antenna



Mobile Phones
Tablets
Mobile Gaming

Bluetooth

WLAN
802.11b/g
Zigbee
802.15

IMT and WiMax Bands
TDD LTE Bands
And Other Apps

2.45GHz / 2.47GHz
AMCA31-2R450G-S1F-T
AMCA72-2R470G-S1F-T

ALL REMAINING PARTS

Chip Antennas are useful for mobile wireless systems where a compact solution is required

Crystals
Oscillators
Filters
Precision Timing
Inductors

ABRACON CORPORATION



Applications for Chip Antennas

- o Chip Antennas are used extensively by the mobile phone manufacturers, but these tier 1 customers are not our targets

- o **Bluetooth Applications:**
 - o Bluetooth exists in many products, such as telephones, tablets, media players, and gaming like Lego Mindstorms NXT, Playstation 3, PS Vita, Nintendo Wii, and HD Headsets, Modems and watches:

 - o Bluetooth Headsets / Intercoms
 - o Bluetooth Audio Headsets
 - o Keyboards / Mouse
 - o Games Consoles / Controllers
 - o Wireless bridge between two Industrial Ethernet (e.g. PROFINET) networks.
 - o Short range transmission of health sensor data from medical devices to mobile phone, or dedicated “Telehealth” devices.
 - o Personal security applications – tags

The Bluetooth technology offers a wide selection of applications involved with Bluetooth enabled devices.

Crystals
Oscillators
Filters
Precision Timing
Inductors



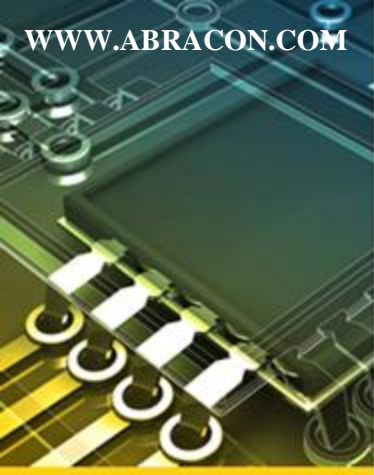

Applications for Chip Antennas

- o **WiFi Applications: The “Internet of Things”**
 - o The number of Internet-connected devices in the world in 2011 was estimated at 20 billion by 2020 this is expected to rise to 50 billion devices.
 - o Networking
 - o Consumer Electronics
 - o Computing and Peripherals
 - o Headsets
 - o Automotive and Transport
 - o Health & Fitness
 - o Smart Energy
 - o Industrial Communications

**Crystals
Oscillators
Filters
Precision Timing
Inductors**



The “Internet of Things” offers an increasing wide application of connected or controlled WiFi solutions. A wide selection of WiFi certified product exist, and offer opportunities for Chip Antennas.



Applications for Chip Antennas

IMT Standardization:

IMT-2000 / IMT Advanced:

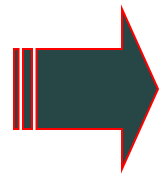

IMT Standards Drives Technology and Telecom Operators to invest in infrastructure

IMT Applications:

- o **Mobile Health**
 - Easy to carry devices
 - Better coverage
 - Backhaul capability for body sensor devices
- o **Smart Energy**
 - Smart Appliances
 - Programmable wireless connected thermostats
 - Adoption of smart energy devices in medium to dense residential areas
- o **Smart City**
 - Telematics
 - Environmental control
 - Public safety (webcam monitoring)
- o **Architecture of Internet of Things**
 - Ubiquitous wireless Connected World

**Crystals
Oscillators
Filters
Precision Timing
Inductors**



IMT Standards drive Ubiquitous wireless Connected World and generation of new applications



Applications for Chip Antennas

WiMax - 802.16 - Worldwide Interoperability for Microwave Access

WiMax is short for Worldwide Interoperability for Microwave Access. It is a metropolitan wireless standard ratified by the IEEE (Institute of Electrical and Electronics Engineers) under the name IEEE-802.16.

Standard	Frequency	Speed
Fixed WiMax (802.16-2004)	2-11 GHz (3.5 GHz in Europe)	75Mbps
Mobile WiMax (802.16e)	2-6 GHz	30Mbps

The AMCA antenna can be used in WiMax User Equipment (UE) devices, like dongles, laptops, mobile wireless.

WiMax standard is a metropolitan wireless standard. The AMCA chip antennas cover global bands for WiMax user equipments. They can be used in dongles, mobiles and wireless devices to connect to the internet.

Crystals
Oscillators
Filters
Precision Timing
Inductors





Applications for Chip Antennas

E-UTRA and LTE-Advanced

The range of AMCA antenna cover certain E-UTRA TDD bands (LTE), between 2.3GHz to 3.6GHz

LTE Band	Frequency (MHZ)	Duplex	Common Name	Antenna PN	Antenna B/W (MHz)
38	2570 - 2620	TDD	IMT-E / 2600	AMCA92-2R660G-S1F-T	1660 - 3660
40	2300 - 2400	TDD	2300	AMCA52-2R350G-S1F-T	2275 - 2425
42	3400 - 3600	TDD	3500	AMCA81-3R010G-S1F-T	2010 - 4010

The AMCA antenna can be used in WiMax User Equipment (UE) devices, like dongles, laptops, mobile wireless.

The AMCA chip antennas cover several of the E-UTRA and LTE-Advanced bands, and can be used in user equipments like dongles, or other LTE equipments covering these bands.

**Crystals
Oscillators
Filters
Precision Timing
Inductors**





Cross Reference Guide

**Crystals
Oscillators
Filters
Precision Timing
Inductors**



ABRACON	MURATA	YAGEO (PHYCOMP)	TAIYO YUDEN	JOHANSON TECHNOLOGY Inc	ANTENOVA
AMCA31-2R450G-S1F-T	ANCV12G44SAA127	CAN4311712002451K	AH316M245001-T	2450AT42A100	A10192-L
AMCA31-2R800G-S1F-T	LDA212G8610K-285				
AMCA52-2R350G-S1F-T			AH104F2350S1-T		
AMCA52-2R510G-S1F-T				2500AT43A0100	
AMCA52-2R540G-S1F-T			AH104F2550S1-T		
AMCA52-2R710G-S1F-T	2500AT43A0100				
AMCA52-2R780G-S1F-T					
AMCA62-2R640G-01F-T	LDA212G4410K-283		AH104F2650S1-T	2600AT44A0600E	
AMCA72-2R470G-S1F-T					
AMCA72-2R860G-02F-T	LDA212G8610K-285				
AMCA81-3R010G-S1F-T	LDA313G0313F-240				
AMCA92-2R660G-S1F-T				2650AT43A0100E	

The table summarizes the best matches offered by the ACA series to other antenna company products. Products are alternatives and may not be a drop-in solution, so please refer to the specifications.



Antenna Performances

**Crystals
Oscillators
Filters
Precision Timing
Inductors**



P/N	Size	VSWR Max	Gain – Peak / Avg	Qty/Reel	L/T
AMCA31-2R450G-S1F-T	3.2x1.6x1.2mm	<2.0 max	0.5 / -1.0dBi	1k & 3K	8Wks
AMCA31-2R800G-S1F-T	3.2x1.6x1.2mm	<2.0 max	0.5 / -1.0dBi	1k & 3K	8Wks
AMCA52-2R350G-S1F-T	5.2x2.1x1.1mm	<2.0 max	2.5 / 0.5dBi	1K & 4K	8Wks
AMCA52-2R510G-S1F-T	5.2x2.1x1.0mm	<2.0 max	2.5 / 0.5dBi	1K & 4K	8Wks
AMCA52-2R540G-S1F-T	5.2x2.1x1.0mm	<2.0 max	2.5 / 0.5dBi	1K & 4K	8Wks
AMCA52-2R710G-S1F-T	5.2x2.1x1.0mm	<2.0 max	2.5 / 0.5dBi	1K & 4K	8Wks
AMCA52-2R780G-S1F-T	5.2x2.1x1.0mm	<2.0 max	2.5 / 0.5dBi	1K & 4K	8Wks
AMCA62-2R640G-01F-T	6.0x2.0x1.0mm	<2.0 max	2.6 / 0.7dBi	1K & 4K	8Wks
AMCA72-2R470G-S1F-T	7.0x2.0x1.0mm	<2.0 max	2.7 / 1.0dBi	1K & 4K	8Wks
AMCA72-2R860G-02F-T	7.0x2.0x1.0mm	<2.0 max	2.7 / 1.0dBi	1K & 4K	8Wks
AMCA81-3R010G-S1F-T	8.0x1.0x1.0mm	<2.0 max	2.0 / 0.5dBi	1K & 4K	8Wks
AMCA92-2R660G-S1F-T	9.0x2.0x1.0mm	<2.0 max	3.0 / 1.0dBi	1K & 4K	8Wks

The table summarizes the suggested the technology advantages of size, efficiency and gain offered by the AMCA Series.

Thank You for your Kind Attention

Abracon Multilayer
Chip Antennas