

THE NEW VALUE FRONTIER



Capacitors

2018



KYOCERA Corporation

Capacitors

How to Order	1
Dimensions etc.	2
General CM Series	3 – 5
Low Profile CT Series	6
High-Q CU Series	6
Au Termination AT Series	7
Soft Termination ST Series	7
High Voltage CF Series	8
Three Terminal Capacitors KNH Series	9
Test Conditions and Standards	10 – 13
Packaging	14 – 15
Precautions	16 – 19
Part Number List	20 – 25
Notes for Using the Catalog	26
Design Tool Introduction	26

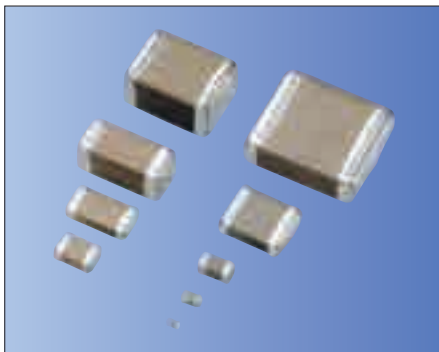

RoHS Compliant

■ Features

- Kyocera's series of Multilayer Ceramic Chip Capacitors are designed to meet a wide variety of needs. We offer a complete range of products for both general and specialized applications.
- We have a network worldwide in order to supply our global customer bases quickly and efficiently and to maintain our reputation as one of the highest-volume producers in the industry
- All our products are highly reliable due to their monolithic structure of high-purity and superfine uniform ceramics and their integral internal electrodes.
- By combining superior manufacturing technology and materials with high dielectric constants, we produce extremely compact components with exceptional specifications.
- Our stringent quality control in every phase of production from material procurement to shipping ensures consistent manufacturing and super quality.
- Kyocera components are available in a wide choice of dimensions, temperature characteristics, rated voltages, and terminations to meet specific configurational requirements.

(Example)

- ① Series : CM Series(General)
- ② Size : 0201
- ③ Dielectric : X5R
- ④ Capacitance : 2.2μF
- ⑤ Tolerance : ±20%
- ⑥ Voltage : 6.3Vdc
- ⑦ Termination : Sn
- ⑧ Packaging : Cavity pitch 2mm / Reel Size φ180

■ KYOCERA PART NUMBER

CM 03 X5R 225 M 06 A H □□□
 ① ② ③ ④ ⑤ ⑥ ⑦ ⑧ OPTION :

Above digits are used to track individual specification or thickness.

① SERIES CODE

CODE	Type
CM	General
CT	Low Profile
CU	High-Q
AT	Au Termination
ST	Soft Termination
CF	High-Voltage
KNH	Three Terminal Capacitors

② Size Code

CODE	EIA	JIS
02	01005	0402
03	0201	0603
05	0402	1005
105	0603	1608
21	0805	2012
316	1206	3216
32	1210	3225
42	1808	4520
43	1812	4532

③ DIELECTRIC CODE

Temperature Compensation Type			
CODE	Temperature Range (°C)	ppm/°C	
CG	-55 to 125	0	±30
CH			±60

- All parts of COG will be marked as "CG" but will conform to the above table.
- Temperature coefficients are determined by calculation based on measurement at 20°C and 85°C.

High Dielectric Constant Type			
CODE	Temperature Range (°C)	ΔC max. (%)	Standard Temperature (°C)
X5R	-55 to 85	±15	25
X7R		±15	
X7S	-55 to 125	±22	

④ CAPACITANCE CODE

Capacitance expressed in pF.
 Two significant digits plus number of zeros.
 For Values < 10pF, Letter R denotes decimal point,
 (<1,000pF = 1nF, 1,000nF = 1μF>)

(Example)

CODE	Capacitance
R50	0.5pF
1R0	1pF
100	10pF
101	100pF
102	1nF
103	10nF
104	100nF
105	1μF
106	10μF

E STANDARD NUMBER					
CODE	E3	E6	E12	E24	
1.0	1.0	1.0	1.0	1.1	
		1.2	1.2	1.3	
	1.5	1.5	1.5	1.6	
		1.8	1.8	2.0	
2.2	2.2	2.2	2.2	2.4	
		2.7	2.7	3.0	
	3.3	3.3	3.3	3.6	
		3.9	3.9	4.3	
4.7	4.7	4.7	5.1		
	5.6	5.6	6.2		
	6.8	6.8	7.5		
	8.2	8.2	9.1		

⑤ TOLERANCE CODE

Temperature Compensation Type (COG)	
CODE	Tolerance
A*	±0.05pF
B	±0.1pF
C	±0.25pF
D	±0.5pF
G*	±2%
J	±5%
K	±10%

* : Option

High Dielectric Constant Type(X5R/X7R/X7S)	
CODE	Tolerance
J*	±5%
K	±10%
M	±20%

* : Option

⑥ VOLTAGE CODE

CODE	Rated Voltage
04	4Vdc
06	6.3Vdc
10	10Vdc
16	16Vdc
25	25Vdc
35	35Vdc
50	50Vdc
100	100Vdc
250	250Vdc
630	630Vdc
1000	1000Vdc
2000	2000Vdc

⑦ TERMINATION CODE

CODE	Termination
A	Nickel Barrier/ Tin
G* ¹	Nickel Barrier/ Au
K* ²	Nickel Barrier/ Au
Y*	Nickel Barrier/ Cu
S	Nickel Barrier/ Tin (Soft Termination)

* : Option

*1: AuSn solder and conductive adhesive.

*2: Wire bonding and conductive adhesive.

⑧ PACKAGING CODE

CODE	Size Code	Cavity pitch	Reel size
T	43	8mm	φ180
	105 to 42	4mm	
H	02 to 05	2mm	φ180
Q	03/05	1mm	
P	02	1mm	
L	105 to 32	4mm	φ330
N	02 to 05	2mm	
W	03/05	1mm	

Dimension

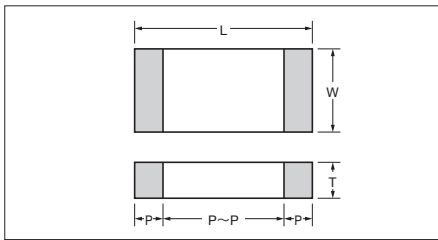

Packaging Code

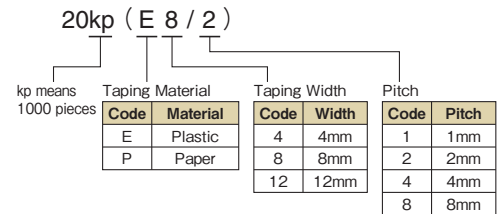

Size	Code		Dimension Code	Dimension (mm)						Maximum quantity per reel						
	EIA	JIS		L	W	T	P min.	P max.	P to P min.	φ 180Reel	φ 330Reel					
02	01005	0402	A	0.4±0.02	0.2±0.02	0.2±0.02	0.07	0.14	0.13	40kp (E4/1) 20kp (P8/2)	80kp (P8/2)					
03	0201	0603	A	0.6±0.03	0.3±0.03	0.22 max.	0.10	0.20	0.20	30kp (P8/1) 15kp (P8/2)	150kp (P8/1) 50kp (P8/2)					
			B			0.3±0.03										
			C	0.6±0.05	0.3±0.05	0.3±0.05	0.13	0.23	0.19	30kp (P8/1) 15kp (P8/2)	150kp (P8/1) 50kp (P8/2)					
			D	0.6±0.09	0.3±0.09	0.25 max.	0.13	0.23	0.19	15kp (P8/2)	—					
			E			0.3±0.09										
			F			0.3±0.10										
05	0402	1005	A	1.0±0.05	0.5±0.05	0.22 max.	0.15	0.35	0.30	20kp (P8/1) 10kp (P8/2)	100kp (P8/1) 50kp (P8/2)					
			B			0.33 max.										
			C			0.5±0.05										
			D	1.0±0.07	0.5±0.07	0.5±0.07	0.15	0.35	0.30	20kp (P8/1) 10kp (P8/2)	—					
			E	1.0±0.10	0.5±0.10	0.5±0.10										
			F*	1.0±0.10	0.5±0.20	0.50 max.	0.05	0.25	—	10kp (P8/2)	—					
			G	1.0±0.15	0.5±0.15	0.5±0.15	0.15	0.35	0.30	20kp (P8/1) 10kp (P8/2)	50kp (P8/2)					
			H	1.0±0.20	0.5±0.20	0.33 max.	0.15	0.35	0.30	10kp (P8/2)	—					
			J			0.5±0.20										
			K*			0.5±0.20										
			A			0.55 max.										
105	0603	1608	A	1.6±0.10	0.8±0.10	0.8±0.10	0.20	0.60	0.50	4kp (P8/4)	10kp (P8/4)					
			B			0.8±0.10										
			C			0.8±0.15										
21	0805	2012	A	2.0±0.10	1.25±0.10	0.95 max.	0.20	0.75	0.70	4kp (P8/4)	10kp (P8/4)					
			B			0.85±0.10										
			C			1.05±0.10										
			D			1.25±0.10										
			E	2.0±0.15	1.25±0.15	0.95 max.	0.20	0.75	0.70	4kp (P8/4) 3kp (E8/4)	10kp (P8/4) 10kp (E8/4)					
			F	1.25±0.15												
			G	0.95 max.												
			H	1.25±0.20												
			A	3.2±0.20	1.6±0.15	1.15±0.10						0.30	0.85	1.40	3kp (E8/4)	10kp (E8/4)
			B	1.6±0.15												
C	1.25±0.10															
D	1.6±0.15															
316	1206	3216	E	3.2±0.20	1.6±0.20	1.6±0.20	0.30	0.85	1.40	2.5kp (E8/4)	5kp (E8/4)					
			F	3.2±0.30	1.6±0.30	1.6±0.30	0.30	0.85	1.90	2kp (E8/4)	5kp (E8/4)					
			A	3.2±0.30	2.5±0.20	1.6±0.15	0.30	1.00	1.40	2.5kp (E8/4)	5kp (E8/4)					
			B			2.0±0.20										
C	2.5±0.20															
42	1808	4520	A	4.5±0.20	2.0±0.20	2.2 max.	0.15	0.85	2.60	2kp (E12/4)	—					
			B	4.5±0.30	3.2±0.20	2.5 max.	0.30	1.10	2.00	0.5kp (E12/8)	—					
			C	—	—	—	—	—	—	—	—					

* : KNH Series

Structure

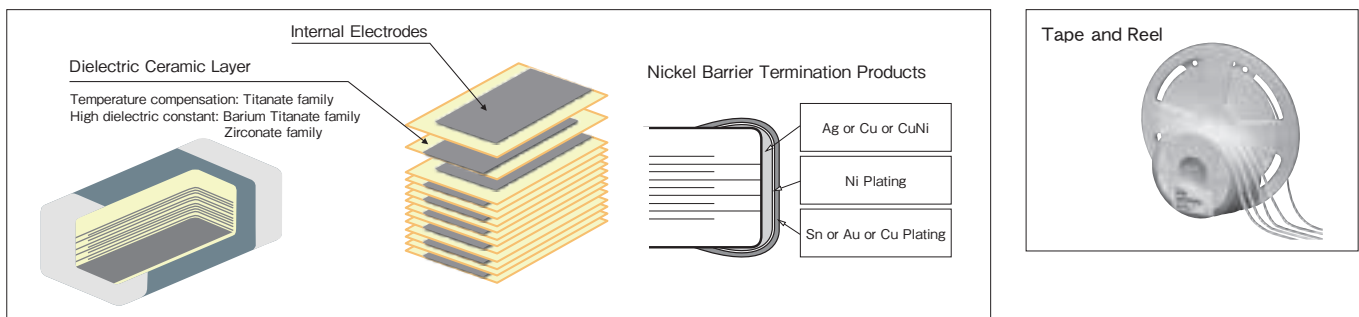

- Please contact your local Kyocera sales office or distributor for specifications not covered in this catalog.
- Our products are continually being improved. As a result, the capacitance range of each series is subject to change without notice. Please contact a sales representative to confirm compatibility with your application.

■ Features

We offer a diverse product line ranging from ultra-compact (0.4×0.2mm) to large (3.2×2.5mm) components configured for a variety of temperature characteristics, rated voltages, and packages. We offer the choice and flexibility for almost any applications.

■ Applications

This standard type is ideal for use in a wide range of applications, from commercial to industrial equipment.

Temperature Compensation Dielectric

Part Number List : P20

● Capacitance chart

Size (EIA Code)	CM02 (01005)	CM03 (0201)	CM05 (0402)	CM105 (0603)
Rated Voltage (Vdc)	16	25	50	50
Capacitance (pF)				
1R0				
1R5				
2.0				
3.0				
4.0				
5.0				
6.0				
7.0				
8.0				
9.0				
100				
120				
12				
15				
18				
22				
27				
33				
39				
47				
56				
68				
82				
101				
100				
121				
120				
150				
180				
220				
270				
330				
390				
470				
560				
102				
680				
820				
1000				

Alphabets in capacitance chart denote dimensions. Please refer to the below table for detail.

(Example)
In case of "B" for CM03;
L : 0.6±0.03mm
W : 0.3±0.03mm
T : 0.3±0.03mm

Size	Size Code	Dimension (mm)		
		L	W	T
02	A	0.4±0.02	0.2±0.02	0.2±0.02
03	B	0.6±0.03	0.3±0.03	0.3±0.03
05	C	1.0±0.05	0.5±0.05	0.5±0.05
105	B	1.6±0.10	0.8±0.10	0.8±0.10

<Standard Capacitance Value>

- E12 Series

Please contact for capacitance value other than standard.

▨ : Optional Spec.

X5R Dielectric

Part Number List : P21-23

● Capacitance chart

Size (EIA Code)	CM02 (01005)		CM03 (0201)					CM05 (0402)					CM105 (0603)						
	Rated Voltage (Vdc)	Capacitance (pF)	6.3	16	4	6.3	10	16	25	4	6.3	10	16	25	35	6.3	10	16	25
101	100																		
151	150																		
	220																		
	330																		
102	470																		
	680																		
	1000			A8															
152	1500																		
	2200																		
	3300																		
103	4700																		
	6800																		
	10000																		
153	15000																		
	22000																		
	33000																		
	47000																		
	68000																		
	100000																		
104	220000																		
	470000																		
	1000000																		
105	2200000																		
	4700000																		
	10000000																		
106	22000000																		
	47000000																		
	150000000																		
	220000000																		

Size (EIA Code)	CM21 (0805)					CM316 (1206)					CM32 (1210)							
	Rated Voltage (Vdc)	Capacitance (pF)	6.3	10	16	25	50	6.3	10	16	25	50	100	6.3	10	16	25	50
105	10000000																	
	22000000																	
	47000000																	
	100000000																	
106	220000000																	
	470000000																	

<Standard Capacitance Value>

Capacitance value of less than 0.1μF: E6 Series

Capacitance value of 0.1μF and larger : E3 Series

Please contact for capacitance value other than standard.

▨ : Optional Spec.

Two digits alphanumeric in capacitance chart denote dimensions and tan δ.
Please refer to the below table for detail.

(Example)

In case of "B3" for CM03;
L : 0.6±0.03mm
W : 0.3±0.03mm
T : 0.3±0.03mm
Tan δ : 5.0% max.

Size	Size Code	Dimension (mm)		
		L	W	T
02	A	0.4±0.02	0.2±0.02	0.2±0.02
	B	0.6±0.03	0.3±0.03	0.3±0.03
03	C	0.6±0.05	0.3±0.05	0.3±0.05
	E	0.6±0.09	0.3±0.09	0.3±0.09
	J	1.0±0.20	0.5±0.20	0.5±0.20
05	C	1.0±0.05	0.5±0.05	0.5±0.05
	G	1.0±0.15	0.5±0.15	0.5±0.15
	J	1.0±0.20	0.5±0.20	0.5±0.20
105	B	1.6±0.10	0.8±0.10	0.8±0.10
	C	1.6±0.15	0.8±0.15	0.8±0.15
21	D	2.0±0.10	1.25±0.10	1.25±0.10
	F	2.0±0.15	1.25±0.15	1.25±0.15
	H	2.0±0.20	1.25±0.20	1.25±0.20
316	C	3.2±0.20	1.6±0.15	1.6±0.15
	D	3.2±0.20	1.6±0.20	1.6±0.20
32	C	3.2±0.30	2.5±0.20	2.5±0.20

Tan δ Code	Tan δ
3	5.0%max.
4	7.0%max.
5	7.5%max.
7	10.0%max.
8	12.5%max.
9	15.0%max.
10	20.0%max.

X7R Dielectric

Part Number List : P21-23

●Capacitance chart

Size (EIA Code)	CM02 (01005)	CM03 (0201)			CM05 (0402)	CM105 (0603)			CM21 (0805)				
Rated Voltage (Vdc) Capacitance (pF)	16	10	16	25	25	6.3	10	16	6.3	10	16	25	50
101 100	A8			B2									
151 150													
220 330													
102 470			B2										
152 680													
2200 3300		B3											
103 4700													
153 6800													
22000 33000													
104 47000													
154 68000													
220000 330000													
105 470000													
155 680000													
2200000 3300000													
106 4700000													
156 6800000													
22000000 33000000													

Size (EIA Code)	CM316 (1206)					CM32 (1210)		
Rated Voltage (Vdc) Capacitance (pF)	6.3	10	16	25	50	16	25	50
106 22000000								
47000000								
100000000								
220000000								

<Standard Capacitance Value>
 Capacitance value of less than 0.1μF: E6 Series
 Capacitance value of 0.1μF and larger : E3 Series
 Please contact for capacitance value other than standard.

▨ : Optional Spec.

Two digits alphanumeric in capacitance chart denote dimensions and tan δ.
 Please refer to the below table for detail.

(Example)
 In case of "B3" for CM03;
 L : 0.6±0.03mm
 W : 0.3±0.03mm
 T : 0.3±0.03mm
 Tan δ : 5.0% max.

Size	Size Code	Dimension (mm)		
		L	W	T
02	A	0.4±0.02	0.2±0.02	0.2±0.02
03	B	0.6±0.03	0.3±0.03	0.3±0.03
05	C	1.0±0.05	0.5±0.05	0.5±0.05
105	B	1.6±0.10	0.8±0.10	0.8±0.10
	C	1.6±0.15	0.8±0.15	0.8±0.15
21	D	2.0±0.10	1.25±0.10	1.25±0.10
	H	2.0±0.20	1.25±0.20	1.25±0.20
316	D	3.2±0.20	1.6±0.20	1.6±0.20
32	C	3.2±0.30	2.5±0.20	2.5±0.20

Tan δ Code	Tan δ
2	3.5%max.
3	5.0%max.
5	7.5%max.
8	12.5%max.

X7S Dielectric

Part Number List : P22

●Capacitance chart

Size (EIA Code)	CM316 (1206)
Rated Voltage (Vdc) Capacitance (pF)	100
105 1000000	
2200000	
4700000	
106 10000000	

Two digits alphanumeric in capacitance chart denote dimensions and tan δ.
 Please refer to the above table for detail.

(Example)
 In case of "D3" for CM316;
 L : 3.2±0.20mm
 W : 1.6±0.20mm
 T : 1.6±0.20mm
 Tan δ : 5.0% max.

Size	Size Code	Dimension (mm)		
		L	W	T
316	D	3.2±0.20	1.6±0.20	1.6±0.20
	E	3.2±0.30	1.6±0.30	1.6±0.30

Tan δ Code	Tan δ
3	5.0%max.

▨ : Optional Spec.

Low Profile CT Series

【RoHS Compliant Products】

■ Features

This low profile series is ideal where height clearance is limited

■ Applications

Circuits requiring a compact, low-profile design, such as module and memory cards.

X5R Dielectric

Part Number List : P23

● Capacitance chart

Size (EIA Code)	CT03 (0201)	CT05 (0402)	CT105 (0603)	CT21 (0805)		
Rated Voltage (Vdc)	6.3	6.3	16	16	25	50
Capacitance (pF)	6.3	6.3	16	16	25	50
104	100000	A8				
	220000					
	470000					
105	1000000	D8	B8	A8	A3	
	2200000					G3
	4700000			E3		
106	10000000					

Option Spec.

Two digits alphanumeric in capacitance chart denote dimensions and tan δ. Please refer to the below table for detail.

(Example)
In case of "B8" for CT05;
L : 1.0±0.05mm
W : 0.5±0.05mm
T : 0.33mm max.
Tan δ : 12.5% max.

Size	Size Code	Dimension (mm)			Tan δ Code	Tan δ
		L	W	T		
03	A	0.6±0.03	0.3±0.03	0.22 max.	3	5.0%max.
	D	0.6±0.09	0.3±0.09	0.25 max.	8	12.5%max.
05	A	1.0±0.05	0.5±0.05	0.22 max.	9	15.0%max.
	B	1.0±0.05	0.5±0.05	0.33 max.		
	H	1.0±0.20	0.5±0.20	0.33 max.		
105	A	1.6±0.10	0.8±0.10	0.55 max.		
21	A	2.0±0.10	1.25±0.10	0.95 max.		
	E	2.0±0.15	1.25±0.15	0.95 max.		
	G	2.0±0.20	1.25±0.20	0.95 max.		

High-Q CU Series

【RoHS Compliant Products】

■ Features

Ultra-miniature size (0.4x0.2mm)
Low loss characteristics suitable for high frequency

■ Applications

● RF power amplifier for mobiles such as impedance matching purpose.

Temperature Compensation Dielectric

Part Number List : P23

● Capacitance chart

Size (EIA Code)	CU02 (01005)
Rated Voltage (Vdc)	16
Capacitance (pF)	16
R20	0.2
R50	0.5
1R0	1.0
1R5	1.5
	2.0
	3.0
	4.0
	5.0
	6.0
	7.0
	8.0
	9.0
100	10
120	12
	15
	18
	22

<Standard Capacitance Value>

· E12 Series

Please contact for capacitance value other than standard.

Alphabets in capacitance chart denote dimensions. Please refer to the below table for detail.

(Example)
In case of "A" for CU02;
L : 0.4±0.02mm
W : 0.2±0.02mm
T : 0.2±0.02mm

Size	Size Code	Dimension (mm)		
		L	W	T
02	A	0.4±0.02	0.2±0.02	0.2±0.02

■ Features

Enables wire bonding, AuSn solder and conductive adhesive assembly by Au plated external termination electrodes.

■ Applications

- Optical communications
- Inside of IC packages

X5R Dielectric

Part Number List : P24

● Capacitance chart

Size (EIA Code)	AT02 (01005)	AT03 (0201)	AT05 (0402)
Rated Voltage (Vdc)	6.3	6.3	6.3
Capacitance (pF)			
104 100000	∕ A8 ∕		
220000			
470000		B8	C8
105 1000000		C8	
2200000		E8	

<Standard Capacitance Value>

· E3 Series

Please contact for capacitance value other than standard.

∕ : Optional Spec.

Two digits alphanumeric in capacitance chart denote dimensions and tan δ. Please refer to the below table for detail.

(Example)
In case of "B3" for AT03;
L : 0.6±0.03mm
W : 0.3±0.03mm
T : 0.3±0.03mm
Tan δ : 12.5% max.

Size	Size Code	Dimension (mm)		
		L	W	T
02	A	0.4±0.02	0.2±0.02	0.2±0.02
03	B	0.6±0.03	0.3±0.03	0.3±0.03
	C	0.6±0.05	0.3±0.05	0.3±0.05
	E	0.6±0.09	0.3±0.09	0.3±0.09
05	C	1.0±0.05	0.5±0.05	0.5±0.05

Tan δ Code	Tan δ
7	10.0%max.
8	12.5%max.

■ Features

Realizes stress relief effect by soft termination which suppresses cracks in dielectrics.

■ Applications

- Electronic equipment for applications such as consumer and industrial uses.

X5R Dielectric

Part Number List : P24

● Capacitance chart

Size (EIA Code)	ST03 (0201)	ST05 (0402)
Rated Voltage (Vdc)	4	6.3
Capacitance (pF)	6.3	10
105 1000000	∕ F8 ∕	∕ D8 ∕
2200000		
4700000		G8
106 10000000		J8

<Standard Capacitance Value>

· E3 Series

Please contact for capacitance value other than standard.

∕ : Optional Spec.

Two digits alphanumeric in capacitance chart denote dimensions and tan δ. Please refer to the below table for detail.

(Example)
In case of "D8" for ST05;
L : 1.0±0.07mm
W : 0.5±0.07mm
T : 0.5±0.07mm
Tan δ : 12.5% max.

Size	Size Code	Dimension (mm)		
		L	W	T
03	C	0.6±0.05	0.3±0.05	0.3±0.05
	F	0.6±0.10	0.3±0.10	0.3±0.10
05	D	1.0±0.07	0.5±0.07	0.5±0.07
	G	1.0±0.15	0.5±0.15	0.5±0.15
	J	1.0±0.20	0.5±0.20	0.5±0.20

Tan δ Code	Tan δ
8	12.5%max.

■ Structure

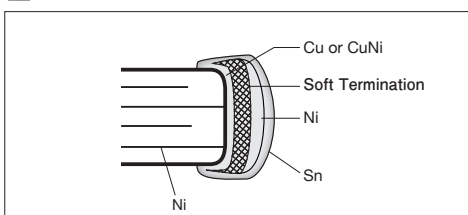

■ Features

Perform less than 1 fit failure ratio by high voltage durability and high reliability which has optimized internal electrode structure based on designing of safety.

	General Spec.	Mid-voltage range		
	Straight structure	Straight structure	Dual cascade	Triple cascade
Internal structure				
Equivalent circuit				

• Mid-voltage range (Straight structure)

Secure break-down voltage margin with proper suitable dielectric thickness for each rated voltage.

• Mid-voltage range (Dual cascade structure)

Achieves high rated voltage by series connection of two capacitor units in one MLCC to divide applied voltage into two. Also, it has good protection against transient voltage.

• Mid-voltage range (Triple cascade structure)

Achieves high rated voltage by series connection of three capacitor units in one MLCC to divide applied voltage into three. Excellent safety against high voltage.

The multi cascade design prevents short circuit failure which results in excellent reliability

■ Applications

- Camera/ Strobe circuit, Surge killing, Trigger circuit
- LCD back light inverter, Ballast capacitor
- Power circuit/ DC-DC converter, Snubber circuit

X7R Dielectric

Part Number List : P24-25

● Capacitance chart

Size (EIA Code)	CF21 (0805)	CF316 (1206)			CF32 (1210)			CF42 (1808)		CF43 (1812)				
	250	250	630	1000	250	630	1000	1000	2000	250	630	1000	2000	
102 220 470 1000	B1			A1 B1 C1						A1				A1
103 2200 4700 10000	C1		B1 C1				A1	A1						
104 22000 47000 100000 220000	D1	A1 C1				B1	A1 B1					A1		

<Standard Capacitance Value>

• E3 Series

Please contact for capacitance value other than standard.

Two digits alphanumeric in capacitance chart denote dimensions and $\tan \delta$.

Please refer to the below table for detail.

(Example)
In case of "B1" for CF21;
L : $2.0 \pm 0.1\text{mm}$
W : $1.25 \pm 0.1\text{mm}$
T : $0.85 \pm 0.1\text{mm}$
 $\tan \delta$: 2.5% max.

Size	Size Code	Dimension (mm)		
		L	W	T
21	B	2.0 ± 0.10	1.25 ± 0.10	0.85 ± 0.10
	C	2.0 ± 0.10	1.25 ± 0.10	1.05 ± 0.10
	D	2.0 ± 0.10	1.25 ± 0.10	1.25 ± 0.10
316	A	3.2 ± 0.20	1.6 ± 0.15	1.15 ± 0.10
	B	3.2 ± 0.20	1.6 ± 0.15	1.25 ± 0.10
	C	3.2 ± 0.20	1.6 ± 0.15	1.6 ± 0.15
32	A	3.2 ± 0.30	2.5 ± 0.20	1.6 ± 0.15
	B	3.2 ± 0.30	2.5 ± 0.20	2.0 ± 0.20
42	A	4.5 ± 0.20	2.0 ± 0.20	2.2 max.
43	A	4.5 ± 0.30	3.2 ± 0.20	2.5 max.

Tan δ Code	Tan δ
1	2.5% max.

■ Features

0402 Size. Rated current up to 2A MAX.
 With unique circuit structure, this three terminal capacitor enables noise reduction in wide frequency range. With its high capacitance, it is possible to reduce the number of components being used.

■ Applications

- PCs, Laser Printers, Cellular Phone, Power/ Signal Lines for LCD Display, Office Equipments
- V Power Supply/ Signal Line, TV, VCR, etc.
- High Current Signal Lines

X5R Dielectric

Part Number List : P25

● Capacitance chart

Size (EIA Code)	KNH05 (0402)								
Rated Voltage (Vdc)	4								
Capacitance (pF)									
105 1000000									
435 4300000									
106 10000000									
	<table border="1"> <tr> <td style="width: 10px; height: 10px; background-color: #cccccc;"></td> <td style="width: 10px; height: 10px; background-color: #cccccc;"></td> <td style="width: 10px; height: 10px; background-color: #cccccc;"></td> <td style="width: 10px; height: 10px; background-color: #cccccc;"></td> </tr> <tr> <td style="text-align: center;">F</td> <td style="text-align: center;">K</td> <td style="text-align: center;">K</td> <td style="text-align: center;">K</td> </tr> </table>					F	K	K	K
F	K	K	K						

• Storage condition
 Temperature: -10 to +45°C
 Humidity: 45 to 75%RH
 : Optional Spec.

Alphabets in capacitance chart denote dimensions. Please refer to the below table for detail.

(Example)
 In case of "K" for KNH05;
 L : 1.0±0.20mm
 W : 0.5±0.20mm
 T : 0.5±0.20mm

Size Code	Dimension (mm)					
	L	W	T	G	P	R
F	1.0±0.10	0.5±0.20	0.50 max.	0.3±0.10	0.15±0.10	≥0.05
K	1.0±0.20	0.5±0.20	0.5±0.20	0.3±0.10	0.15±0.10	≥0.05

■ Dimension

(Unit: mm)

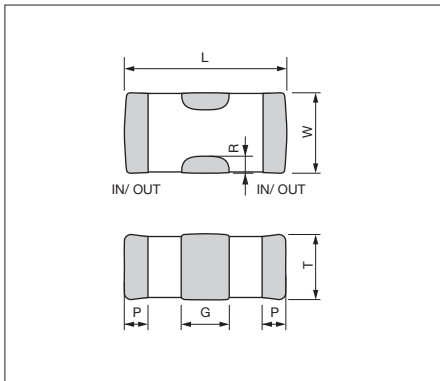

■ Recommended Land Pattern

(Unit: mm)

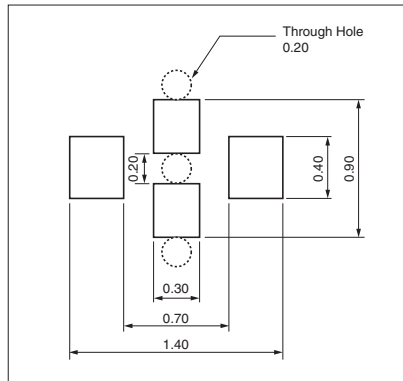

Test Conditions and Standards

Test Conditions and Specifications for Temperature Compensation Type (C Δ Characteristics)
CM / CU Series

Test Items		Test Conditions	Specifications								
Capacitance Value (C)			Within tolerance								
Q	<table border="1"> <thead> <tr> <th>Capacitance</th> <th>Frequency</th> <th>Volt</th> </tr> </thead> <tbody> <tr> <td>C ≤ 1000pF</td> <td>1MHz ± 10%</td> <td rowspan="2">0.5 to 5Vrms</td> </tr> <tr> <td>C > 1000pF</td> <td>1kHz ± 10%</td> </tr> </tbody> </table>		Capacitance	Frequency	Volt	C ≤ 1000pF	1MHz ± 10%	0.5 to 5Vrms	C > 1000pF	1kHz ± 10%	C ≥ 30pF : Q ≥ 1000 C < 30pF : Q ≥ 400+20C
	Capacitance	Frequency	Volt								
C ≤ 1000pF	1MHz ± 10%	0.5 to 5Vrms									
C > 1000pF	1kHz ± 10%										
Insulation Resistance (IR)		Measured after the rated voltage is applied for 1 minute at room ambient. The charge and discharge current of the capacitor must not exceed 50mA.	Over 10000MΩ or 500MΩ · μF, whichever is less								
Dielectric Resistance		Apply 3 times of the rated voltage for 1 to 5 seconds. The charge and discharge current of the capacitor must not exceed 50mA.	No problem observed								
Appearance		Microscope	No problem observed								
Termination Strength		Apply a sideward force of 500g (5N) to a PCB-mounted sample. Apply 2N for 0201, and 1N for 01005 size.	No problem observed								
Bending Strength		Glass epoxy PCB: Fulcrum spacing: 90mm, duration time 10 seconds.	No significant damage at 1mm bent								
Vibration Test	Appearance	Vibration frequency: 10 to 55 (Hz) Amplitude: 1.5mm Sweeping condition: 10 → 55 → 10Hz/ 1 minute in X, Y and Z Directions: 2 hours each, 6 hours total.	No problem observed								
	Δ C		Within Tolerance								
	Q		C ≥ 30pF : Q ≥ 1000 C < 30pF : Q ≥ 400+20C								
Soldering Heat Resistance	Appearance	Soak the sample in 260°C ± 5°C solder for 10 ± 0.5 seconds and place in room ambient, and measure after 24 ± 2 hours. (Pre-heating conditions)	No problem observed								
	Δ C		Within ± 2.5% or ± 0.25pF, whichever is larger								
	Q		C ≥ 30pF : Q ≥ 1000 C < 30pF : Q ≥ 400+20C								
	IR		Over 10000MΩ or 500MΩ · μF whichever is less								
	Withstanding Voltage		<table border="1"> <thead> <tr> <th>Order</th> <th>Temperature</th> <th>Time</th> </tr> </thead> <tbody> <tr> <td>1</td> <td>80 to 100°C</td> <td>2 minutes</td> </tr> <tr> <td>2</td> <td>150 to 200°C</td> <td>2 minutes</td> </tr> </tbody> </table> The charge and discharge current of the capacitor must not exceed 50mA for IR and withstanding voltage measurement.	Order	Temperature	Time	1	80 to 100°C	2 minutes	2	150 to 200°C
Order	Temperature	Time									
1	80 to 100°C	2 minutes									
2	150 to 200°C	2 minutes									
Solderability		Soaking condition	Solder coverage : 90% min.								
Temperature Cycle	Appearance	(Cycle) Room temperature (3min.) → Lowest operation temperature (30min.) → Room temperature (3min.) → Highest operation temperature (30min.) After 5 cycles, measure after 24 ± 2 hours. The charge and discharge current of the capacitor must not exceed 50mA for IR and withstanding voltage measurement.	No problem observed								
	Δ C		Within ± 2.5% or ± 0.25pF, whichever is larger								
	Q		C ≥ 30pF : Q ≥ 1000 C < 30pF : Q ≥ 400+20C								
	IR		Over 10000MΩ or 500MΩ · μF, whichever is less								
	Withstanding Voltage		Resist without problem								
Load Humidity Test	Appearance	After applying rated voltage for 500+12/ - 0 hours in pre-condition at 40°C ± 2°C, humidity 90 to 95%RH, allow parts to stabilize for 24 ± 2 hours, at room temperature before measurement. The charge and discharge current of the capacitor must not exceed 50mA for IR measurement.	No problem observed								
	Δ C		Within ± 7.5% or ± 0.75pF, whichever is larger								
	Q		C ≥ 30pF : Q ≥ 200 C < 30pF : Q ≥ 100+10C/ 3								
	IR		Over 500MΩ or 25MΩ · μF, whichever is less								
High-Temperature with Loading	Appearance	After applying twice the rated voltage at the temperature of 125 ± 3°C for 1000+12/ - 0 hours, measure the sample after 24 ± 2 hours. The charge and discharge current of the capacitor must not exceed 50mA for IR measurement.	No problem observed.								
	Δ C		Within ± 3% or ± 0.3pF, whichever is larger								
	Q		C ≥ 30pF : Q ≥ 350 10pF < C < 30pF : Q ≥ 275+5C/ 2 C < 10pF : Q ≥ 200+10C								
	IR		Over 1000MΩ or 50MΩ · μF, whichever is less								

Please ask for individual specification for the hatched range in previous chart.

Test Conditions and Standards

Test Conditions and Specifications for High Dielectric Type (X5R, X7R)
CM / CT Series

Test Items		Test Conditions	Specifications									
Capacitance Value (C)		Measure after heat treatment	Within tolerance									
Tanδ		<table border="1"> <thead> <tr> <th>Capacitance</th> <th>Frequency</th> <th>Volt</th> </tr> </thead> <tbody> <tr> <td>C ≤ 10μF</td> <td>1kHz ± 10%</td> <td>1.0 ± 0.2Vrms</td> </tr> <tr> <td>C > 10μF</td> <td>120Hz ± 10%</td> <td>0.5 ± 0.2Vrms</td> </tr> </tbody> </table>	Capacitance	Frequency	Volt	C ≤ 10μF	1kHz ± 10%	1.0 ± 0.2Vrms	C > 10μF	120Hz ± 10%	0.5 ± 0.2Vrms	Refer to capacitance chart
Capacitance	Frequency	Volt										
C ≤ 10μF	1kHz ± 10%	1.0 ± 0.2Vrms										
C > 10μF	120Hz ± 10%	0.5 ± 0.2Vrms										
Insulation Resistance (IR)		Measured after the rated voltage is applied for 1 minute at room ambient. The charge and discharge current of the capacitor must not exceed 50mA.	Over 10000MΩ or 500MΩ · μF, whichever is less									
Dielectric Resistance		Apply 2.5 times of the rated voltage for 1 to 5 seconds. The charge and discharge current of the capacitor must not exceed 50mA.	No problem observed									
Appearance		Microscope	No problem observed									
Termination Strength		Apply a sideward force of 500g (5N) to a PCB-mounted sample. note : 2N for 0201 size, and 1N for 01005 size. Exclude CT series with thickness of less than 0.66mm.	No problem observed									
Bending Strength		Glass epoxy PCB: Fulcrum spacing: 90mm, duration time 10 seconds. Exclude CT series with thickness of less than 0.66mm.	No significant damage at 1mm bent									
Vibration Test	Appearance	Take the initial value after heat treatment. Vibration frequency: 10 to 55 (Hz) Amplitude: 1.5mm Sweeping condition: 10→55→10Hz/ 1 minute in X, Y and Z Directions: 2 hours each, 6 hours total, and place in room ambient, and measure the sample after heat treatment.	No problem observed									
	ΔC		Within tolerance									
	Tanδ		Within tolerance									
Soldering Heat Resistance	Appearance	Take the initial value after heat treatment. Soak the sample in 260°C ± 5°C solder for 10 ± 0.5 seconds and place in room ambient, and measure after heat treatment. (Pre-heating conditions)	No problem observed									
	ΔC		Within ± 7.5%									
	Tanδ		Within tolerance									
	IR	<table border="1"> <thead> <tr> <th>Order</th> <th>Temperature</th> <th>Time</th> </tr> </thead> <tbody> <tr> <td>1</td> <td>80 to 100°C</td> <td>2 minutes</td> </tr> <tr> <td>2</td> <td>150 to 200°C</td> <td>2 minutes</td> </tr> </tbody> </table>	Order	Temperature	Time	1	80 to 100°C	2 minutes	2	150 to 200°C	2 minutes	Over 10000MΩ or 500MΩ · μF, whichever is less
	Order	Temperature	Time									
1	80 to 100°C	2 minutes										
2	150 to 200°C	2 minutes										
Withstanding Voltage	The charge and discharge current of the capacitor must not exceed 50mA for IR and withstanding voltage measurement.	Resist without problem										
Solderability		Soaking condition <table border="1"> <thead> <tr> <th>Sn-3Ag-0.5Cu</th> <th>245 ± 5°C</th> <th>3 ± 0.5 sec.</th> </tr> </thead> <tbody> <tr> <th>Sn63 Solder</th> <th>235 ± 5°C</th> <th>2 ± 0.5 sec.</th> </tr> </tbody> </table>	Sn-3Ag-0.5Cu	245 ± 5°C	3 ± 0.5 sec.	Sn63 Solder	235 ± 5°C	2 ± 0.5 sec.	Solder coverage : 90% min.			
Sn-3Ag-0.5Cu	245 ± 5°C	3 ± 0.5 sec.										
Sn63 Solder	235 ± 5°C	2 ± 0.5 sec.										
Temperature Cycle	Appearance	Take the initial value after heat treatment. (Cycle)	No problem observed									
	ΔC	Room temperature (3min.)→	Within ± 7.5%									
	Tanδ	Lowest operation temperature (30min.)→	Within tolerance									
	IR	Room temperature (3min.)→	Over 10000MΩ or 500MΩ · μF, whichever is less									
	Withstanding Voltage	Highest operation temperature(30min.) After 5 cycles, measure after heat treatment. The charge and discharge current of the capacitor must not exceed 50mA for IR and withstanding voltage measurement.	Resist without problem									
Load Humidity Test	Appearance	Take the initial value after heat treatment. After applying rated voltage for 500+12/- 0 hours in pre-condition at 40°C ± 2°C, humidity 90 to 95%RH, and place in room ambient, and measure the sample after heat treatment.	No problem observed									
	ΔC	The charge and discharge current of the capacitor must not exceed 50mA for IR measurement.	Within ± 12.5%									
	Tanδ		200% max. of initial value									
	IR		Over 500MΩ or 25MΩ · μF, whichever is less									
High-Temperature with Loading	Appearance	Take the initial value after heat treatment. After applying twice the rated voltage at the highest operation temperature for 1000+12/- 0 hours, measure the sample after heat treatment.	No problem observed									
	ΔC	The charge and discharge current of the capacitor must not exceed 50mA for IR measurement.	Within ± 12.5%									
	Tanδ	Apply 1.5 times when the rated voltage is 10V or less. Applied voltages for respective products are indicated in the below chart.	200% max. of initial value									
	IR		Over 1000MΩ or 50MΩ · μF, whichever is less									

Heat treatment Keep specimen at 150+0/- 10°C for 1 hour, leave specimen at room ambient for 24 ± 2 hours.

High-temperature with Loading Applied Voltage (Rated Voltage × □)

Applied Voltage	Rated Voltage	Products
× 1.3	6.3V	CM105X5R475, CM02X5R153-104 CT03X5R104
		CM02X7R101-222, CM105X7R105, CM21X7R475, CM316X7R106, CM32X7R226, CM05X5R224, CM105X5R225, CM21X5R475-106, CM316X5R226 CT105X5R105, CT21X5R225-475, CM02X5R101-103
× 1.5	25V	CM21X7R105-225, CM316X7R475, CM32X7R106, CM105X5R105, CM21X5R225-475, CM316X5R106, CM32X5R106-226 CM03X5R152-103, CM05X7R104
		CM21X5R105, CM32X5R106, CM32X7R106 CT21X5R225
	50V	

Please ask for individual specification for the hatched range in previous chart.

Test Conditions and Standards

Test Conditions and Specifications for High Dielectric Type (X7R) CF Series

Test Items		Test Conditions	Specifications									
Capacitance Value (C)		Measure after heat treatment	Within tolerance									
Tanδ		<table border="1"> <thead> <tr> <th>Capacitance</th> <th>Frequency</th> <th>Volt</th> </tr> </thead> <tbody> <tr> <td>C≤10μF</td> <td>1kHz ± 10%</td> <td>1.0 ± 0.2Vrms</td> </tr> </tbody> </table>	Capacitance	Frequency	Volt	C≤10μF	1kHz ± 10%	1.0 ± 0.2Vrms	Within 2.5%			
Capacitance	Frequency	Volt										
C≤10μF	1kHz ± 10%	1.0 ± 0.2Vrms										
Insulation Resistance (IR)		<p>Measured after the rated voltage is applied for 1 minute at room ambient. Measured after the 500V is applied for 1 minute at room ambient for the rated voltage over 630V. The charge and discharge current of the capacitor must not exceed 50mA.</p>	<p>Over 10000MΩ or 500MΩ · μF, whichever is less Over 100MΩ · μF for CF316X7R104/ 250V</p>									
Dielectric Resistance		<p>Apply 1.5 times when the rated voltage is 250V or over, apply 1.2 times when the rated voltage is 630V or over for 1 to 5 seconds. The charge and discharge current of the capacitor must not exceed 50mA.</p>	No problem observed									
Appearance		Microscope	No problem observed									
Termination Strength		Apply a sideward force of 500g (5N) to a PCB-mounted sample.	No problem observed									
Bending Strength		Glass epoxy PCB: Fulcrum spacing: 90mm, duration time 10 seconds.	No significant damage at 1mm bent									
Vibration Test	Appearance	<p>Take the initial value after heat treatment. Vibration frequency: 10 to 55 (Hz) Amplitude: 1.5mm Sweeping condition: 10→55→10Hz/ 1 minute in X, Y and Z Directions: 2 hours each, 6 hours total.</p>	No problem observed									
	ΔC		Within tolerance									
	Tanδ		Within tolerance									
Soldering Heat Resistance	Appearance	<p>Take the initial value after heat treatment. Soak the sample in 260°C ± 5°C solder for 10 ± 0.5 seconds and place in room ambient, and measure after heat treatment. (Pre-heating conditions)</p> <table border="1"> <thead> <tr> <th>Order</th> <th>Temperature</th> <th>Time</th> </tr> </thead> <tbody> <tr> <td>1</td> <td>80 to 100°C</td> <td>2 minutes</td> </tr> <tr> <td>2</td> <td>150 to 200°C</td> <td>2 minutes</td> </tr> </tbody> </table> <p>The charge and discharge current of the capacitor must not exceed 50mA for IR and withstanding voltage measurement.</p>	Order	Temperature	Time	1	80 to 100°C	2 minutes	2	150 to 200°C	2 minutes	No problem observed
	Order		Temperature	Time								
	1		80 to 100°C	2 minutes								
	2		150 to 200°C	2 minutes								
	ΔC		Within ± 7.5%									
Tanδ(%)	Within tolerance											
IR	<p>Over 10000MΩ or 500MΩ · μF, whichever is less Over 100MΩ · μF for CF316X7R104/ 250V and CF55X7R224/ 630V</p>											
Withstanding Voltage	Resist without problem											
Solderability		<p>Soaking condition</p> <table border="1"> <thead> <tr> <th></th> <th>Temperature</th> <th>Time</th> </tr> </thead> <tbody> <tr> <td>Sn-3Ag-0.5Cu</td> <td>245 ± 5°C</td> <td>3 ± 0.5 sec.</td> </tr> <tr> <td>Sn63 Solder</td> <td>235 ± 5°C</td> <td>2 ± 0.5 sec.</td> </tr> </tbody> </table>		Temperature	Time	Sn-3Ag-0.5Cu	245 ± 5°C	3 ± 0.5 sec.	Sn63 Solder	235 ± 5°C	2 ± 0.5 sec.	Solder coverage : 90% min.
	Temperature	Time										
Sn-3Ag-0.5Cu	245 ± 5°C	3 ± 0.5 sec.										
Sn63 Solder	235 ± 5°C	2 ± 0.5 sec.										
Temperature Cycle	Appearance	<p>Take the initial value after heat treatment. (Cycle) Room temperature (3min.)→ Lowest operation temperature (30min.)→ Room temperature (3min.)→ Highest operation temperature(30min.) After 5 cycles, measure after heat treatment. The charge and discharge current of the capacitor must not exceed 50mA for IR and withstanding voltage measurement.</p>	No problem observed									
	ΔC		Within ± 7.5%									
	Tanδ		Within tolerance									
	IR		<p>Over 10000MΩ or 500MΩ · μF, whichever is less Over 100MΩ · μF for CF316X7R104/ 250V</p>									
	Withstanding Voltage		Resist without problem									
High-Temperature with Loading	Appearance	<p>Take the initial value after heat treatment. After applying specified voltage at the highest operation temperature for 1000+12/- 0 hours, then measure the sample after heat treatment. The applied voltage shall be; 1.5 times the rated voltage when the rated voltage is 250V. 1.2 times when the rated voltage is 630V or over. The charge and discharge current of the capacitor must not exceed 50mA for IR measurement.</p>	No problem observed									
	ΔC		Within ± 12.5%									
	Tanδ		200% max. of initial value									
	IR		Over 1000MΩ or 50MΩ · μF, whichever is less									
Heat treatment		Keep specimen at 150+0/- 10°C for 1 hour, leave specimen at room ambient for 24 ± 2 hours.										

Test Conditions and Standards

Substrate for Adhesion Strength Test, Vibration Test, Soldering Heat Resistance Test, Temperature Cycle Test, Load Humidity Test, High-Temperature with Loading Test.

(Unit: mm)

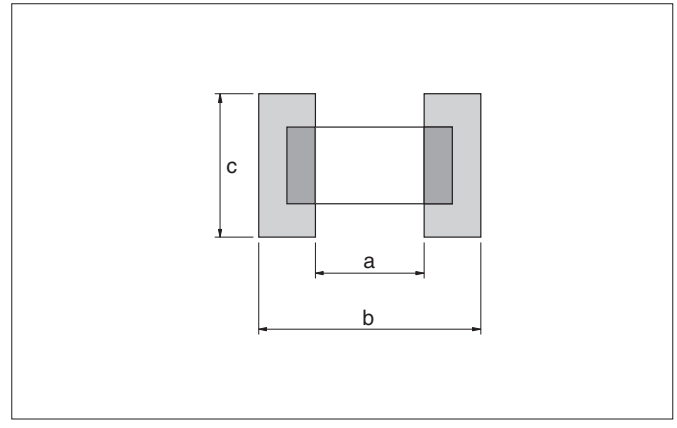

Size (EIA Code)	a	b	c
02 (01005)	0.15	0.50	0.20
03 (0201)	0.26	0.92	0.32
05 (0402)	0.4	1.4	0.5
105 (0603)	1.0	3.0	1.2
21 (0805)	1.2	4.0	1.65
316 (1206)	2.2	5.0	2.0
32 (1210)	2.2	5.0	2.9
42 (1808)	3.5	7.0	3.7
43 (1812)	3.5	7.0	3.7

Substrate for Bending Test

(Unit: mm)

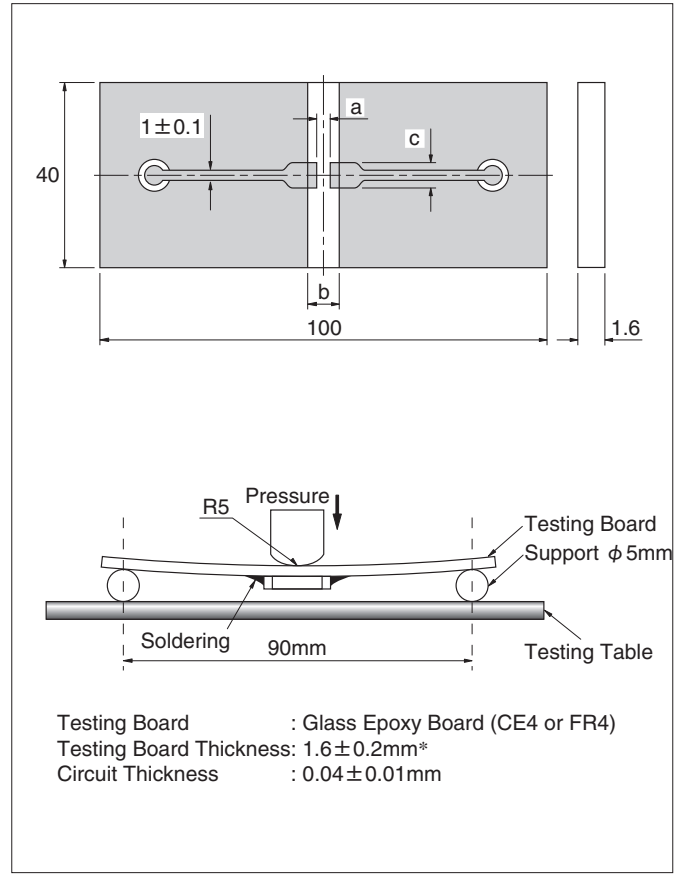

* 02, 03, 05 size 0.8 ± 0.1 mm

Packaging Options

Tape and Reel

• Reel

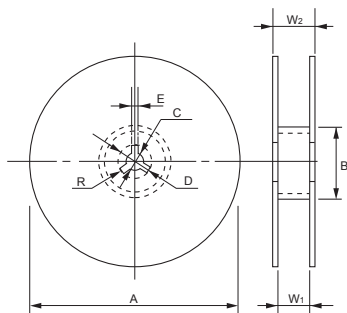

Reel

(Unit: mm)

Code Reel	A	B	C	D
7-inch Reel (CODE: T, H, Q)	180 ⁺⁰ _{-2.0}	φ 60 min.	13±0.5	21±0.8
7-inch Reel (CODE: P)	178±2.0			
13-inch Reel (CODE: L, N, W)	330±2.0			
Code Reel	E	W ₁	W ₂	R
7-inch Reel (CODE: T, H, Q)	2.0±0.5	10.5±1.5	16.5 max.	1.0
7-inch Reel (CODE: P)		4.35±0.3	6.95±1.0	
13-inch Reel (CODE: L, N, W)		9.5±1.0	16.5 max.	

* Carrier tape width 8mm.

For size 42 (1808) or over, Tape width 12mm and W₁: 14 ± 1.5, W₂: 20.5mm max.

Carrier Tape

F=1mm (02 Type)

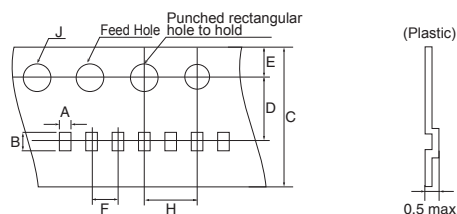

F=4mm (105, 21, 316, 32, 42 Type)

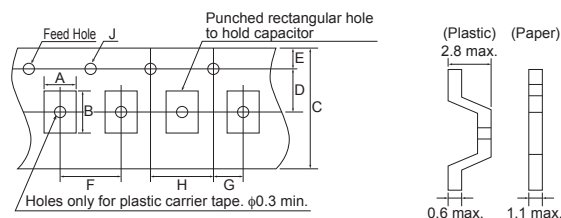

F=1mm (02, 03, 05 Type)

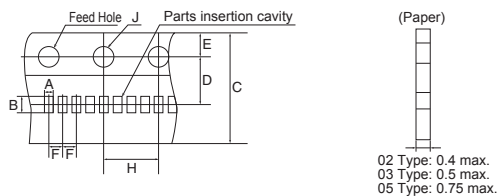

F=8mm (43 Type)

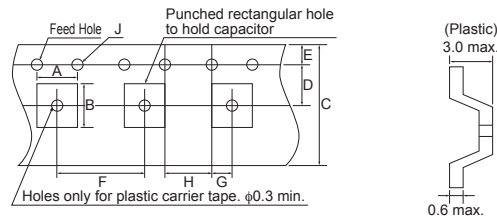

F=2mm (02, 03, 05 Type)

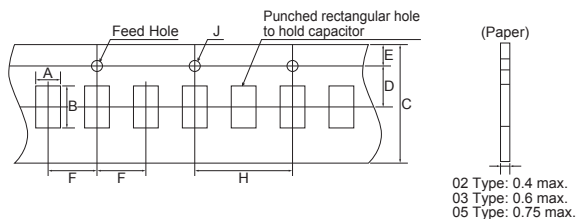

Carrier Tape

(Unit: mm)

Size (EIA Code)	A	B	C	D	E	F	G	H	J	Carrier Tape	
										Width	Material
02 (01005)*	0.23±0.02	0.43±0.02	4.0±0.08	1.8±0.02	0.9±0.05	1.0±0.02	—	2.0±0.04	0.8±0.04	4mm	Plastic
	0.25±0.03	0.45±0.03	8.0±0.3	3.5±0.05	1.75±0.1	2.0±0.05	—	4.0±0.1	1.5+0.1/-0	8mm	Paper
03 (0201)*	0.37±0.03	0.67±0.03	8.0+0.3/-0.1	3.5±0.05	1.75±0.1	1.0±0.05	—	4.0±0.05	1.5+0.1/-0	8mm	Paper
			8.0±0.3			2.0±0.05		4.0±0.1			
05 (0402)*	0.65±0.1	1.15±0.1	8.0+0.3/-0.1	3.5±0.05	1.75±0.1	1.0±0.05	—	4.0±0.05	1.5+0.1/-0	8mm	Paper
	0.75±0.1		8.0±0.3			2.0±0.05		4.0±0.1			
105 (0603)	1.0±0.2	1.8±0.2	8.0±0.3	3.5±0.05	1.75±0.1	4.0±0.1	2.0±0.05	4.0±0.1	1.5+0.1/-0	8mm	Paper
21 (0805)	1.5±0.2	2.3±0.2	8.0±0.3	3.5±0.05	1.75±0.1	4.0±0.1	2.0±0.05	4.0±0.1	1.5+0.1/-0	8mm	Paper
										8mm	Plastic
316 (1206)	2.0±0.2	3.6±0.2	8.0±0.3	3.5±0.05	1.75±0.1	4.0±0.1	2.0±0.05	4.0±0.1	1.5+0.1/-0	8mm	Paper
										8mm	Plastic
32 (1210)	2.9±0.2	3.6±0.2	8.0±0.3	3.5±0.05	1.75±0.1	4.0±0.1	2.0±0.05	4.0±0.1	1.5+0.1/-0	8mm	Plastic
42 (1808)	2.4±0.2	4.9±0.2	12.0±0.3	5.5±0.05	1.75±0.1	4.0±0.1	2.0±0.05	4.0±0.1	1.5+0.1/-0	12mm	Plastic
43 (1812)	3.6±0.2	4.9±0.2	12.0±0.3	5.5±0.05	1.75±0.1	8.0±0.1	2.0±0.05	4.0±0.1	1.5+0.1/-0	12mm	Plastic

* Option

Packaging Options

Detail of leader and trailer

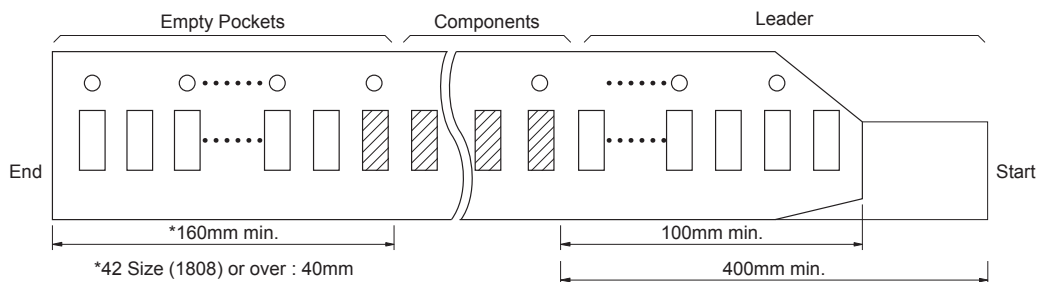

Adhesive tape

- 1) The exfoliative strength when peeling off the top tape from the carrier tape by the method of the following figure shall be *0.1 to 0.7N.
*02 Size: 0.1 to 0.5N
- 2) When the top tape is peeled off, the adhesive stays on the top tape.
- 3) Chip capacitors will be in a state free without being stuck on the thermal adhesive tape.

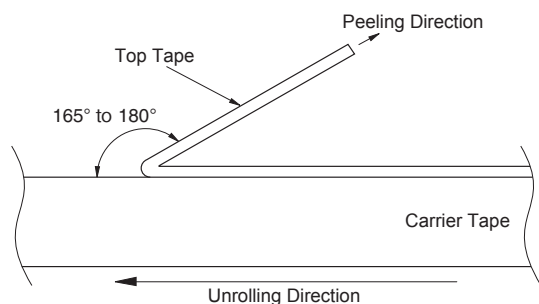

Exfoliating angle: 165 to 180 degrees to the carrier tape.
Exfoliating speed: 300 mm/min.

Carrier tape

- 1) Chip will not fall off from carrier tape or carrier tape will not be damaged by bending than within a radius of 25mm.
- 2) The chip are inserted continuously without any empty pocket.
- 3) Chip will not be mis-mounted because of too big clearance between components and cavity. Also the waste of carrier tape will not fill a nozzle hole of mounting machine.

Packaging quantity

Please refer to Page 2.

Surface Mounting Information

Dimensions for recommended typical land

Since the amount of solder (size of fillet) to be used has direct influence on the capacitor after mounting, the sufficient consideration is necessary.

When the amounts of solder is too much, the stress that a capacitor receives becomes larger. It may become the cause of a crack in the capacitor. When the land design of printed wiring board is considered, it is necessary to set up the form and size of land pattern so that the amount of solder is suitable.

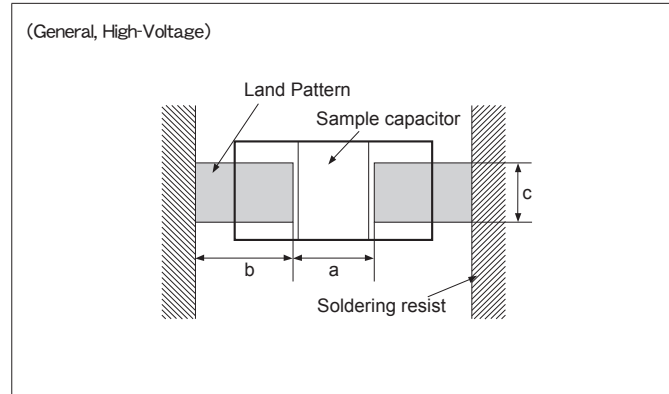

General, High-Voltage

(Unit: mm)

Size (EIA Code)	L×W	a	b	c
02 (01005)	0.4×0.2	0.13 to 0.20	0.12 to 0.18	0.20 to 0.23
03 (0201)	0.6×0.3	0.20 to 0.30	0.25 to 0.35	0.30 to 0.40
05 (0402)	1.0×0.5	0.30 to 0.50	0.35 to 0.45	0.40 to 0.60
105 (0603)	1.6×0.8	0.70 to 1.00	0.80 to 1.00	0.60 to 0.80
21 (0805)	2.0×1.25	1.00 to 1.30	1.00 to 1.20	0.80 to 1.10
316 (1206)	3.2×1.6	2.10 to 2.50	1.10 to 1.30	1.00 to 1.90
32 (1210)	3.2×2.5	2.10 to 2.50	1.10 to 1.30	1.90 to 2.30
42 (1808)	4.5×2.0	3.00 to 3.50	1.80 to 2.30	1.50 to 1.80
43 (1812)	4.5×3.2	3.00 to 3.50	1.80 to 2.30	2.60 to 3.00

* Recommended land dimensions may differ depending on dimensional tolerance.

Design of printed circuit and Soldering

The recommended fillet height shall be 1/2 of the thickness of capacitors or 0.5mm. When mounting two or more capacitors in the common land, it is necessary to separate the land with the solder resist strike so that it may become the exclusive land of each capacitor.

Ideal Solder Height

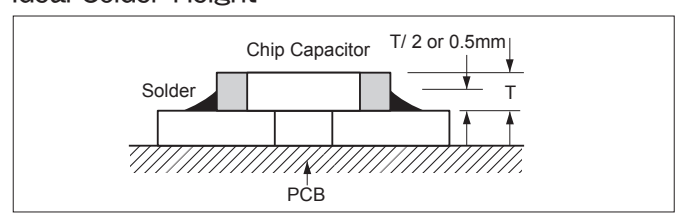

Item	Not recommended example	Recommended example/ Separated by solder
Multiple parts mount		
Mount with leaded parts		
Wire soldering after mounting		
Overview		

Surface Mounting Information

Mounting Design

The chip could crack if the PCB warps during processing after the chip has been soldered.

Recommended chip position on PCB to minimize stress from PCB warpage



Actual Mounting

- 1) If the position of the vacuum nozzle is too low, a large force may be applied to the chip capacitor during mounting, resulting in cracking.
- 2) During mounting, set the nozzle pressure to a static load of 1 to 3 N.
- 3) To minimize the shock of the vacuum nozzle, provide a support pin on the back of the PCB to minimize PCB flexure.

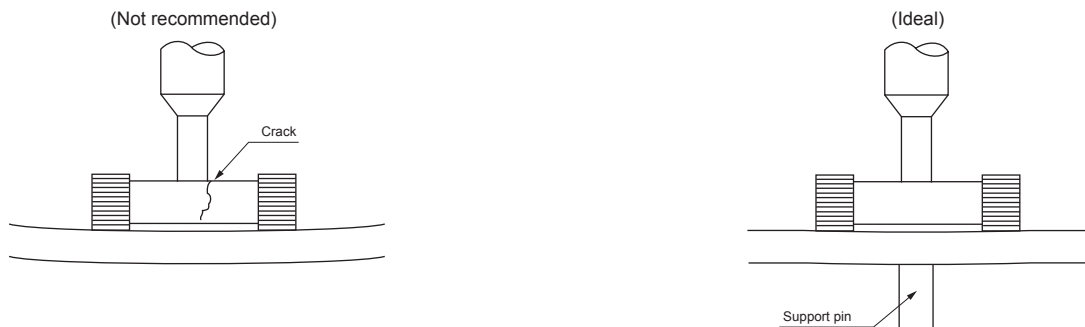

- 4) Bottom position of pick up nozzle should be adjusted to the top surface of a substrate which camber is corrected.

Resin Mold

- 1) If a large amount of resin is used for molding the chip, cracks may occur due to contraction stress during curing. To avoid such cracks, use a low shrinkage resin.
- 2) The insulation resistance of the chip will degrade due to moisture absorption. Use a low moisture absorption resin.
- 3) Check carefully that the resin does not generate a decomposition gas or reaction gas during the curing process or during normal storage. Such gases may crack the chip capacitor or damage the device itself.

Surface Mounting Information

Soldering Method

- 1) Ceramic is easily damaged by rapid heating or cooling. If some heat shock is unavoidable, preheat enough to limit the temperature difference (Delta T) to within 150 degree Celsius.
- 2) The product size 1.6×0.8mm to 3.2×1.6mm can be used in reflow and wave soldering, and the product size of bigger than 3.2×1.6mm, or smaller than 1.6×0.8mm can be used in reflow.
Circuit shortage and smoking can be created by using capacitors which are used neglecting the above caution.
- 3) Please see our recommended soldering conditions.
- 4) In case of using Sn-Zn Solder, please contact us in advance.
- 5) The following condition is recommended for spot heater application.

• Recommended spot heater condition

Item	Condition
Distance	5mm min.
Angle	45°
Projection Temp.	400°C max.
Flow rate	Set at the minimum
Nozzle diameter	2 φ to 4 φ (Single hole type)
Application time	10 sec. max. (1206 and smaller) 30 sec. max. (1210 and larger)

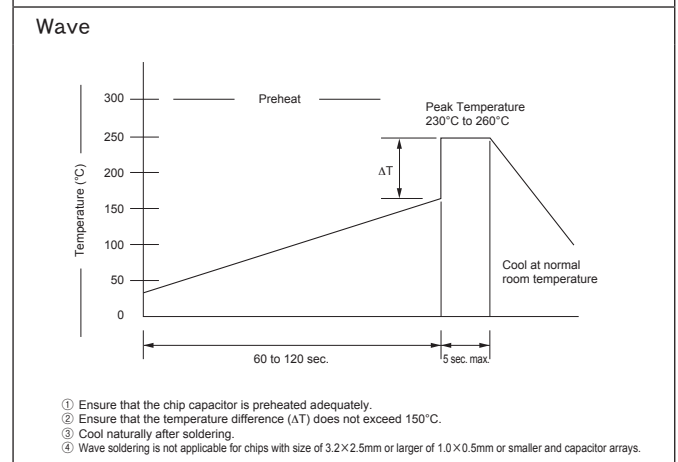
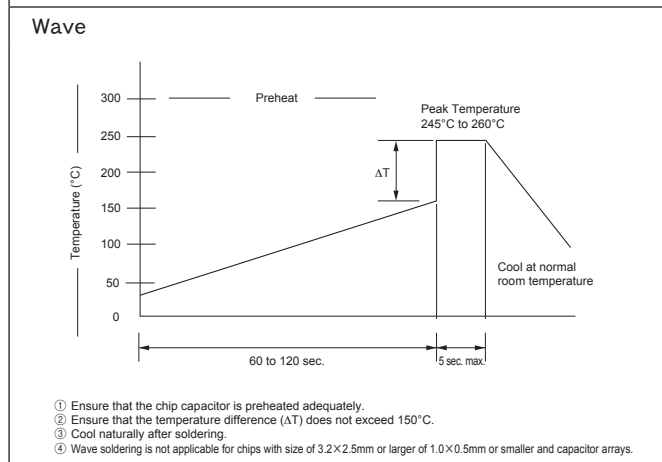
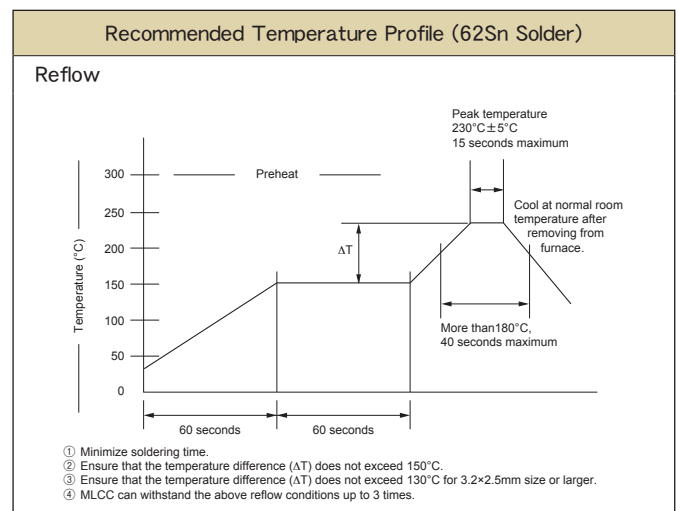
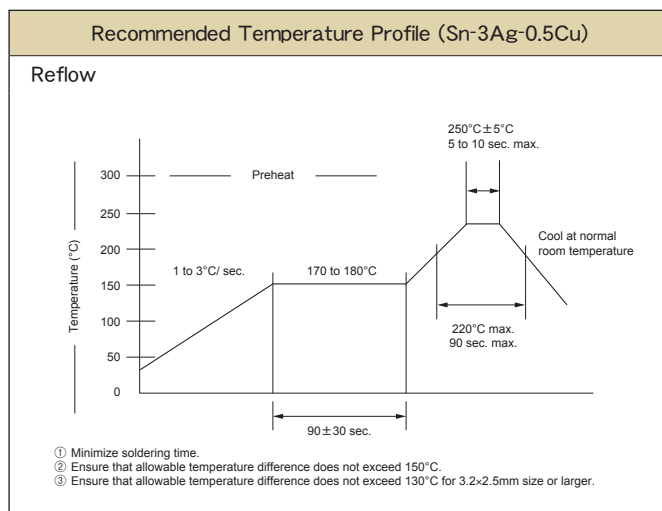
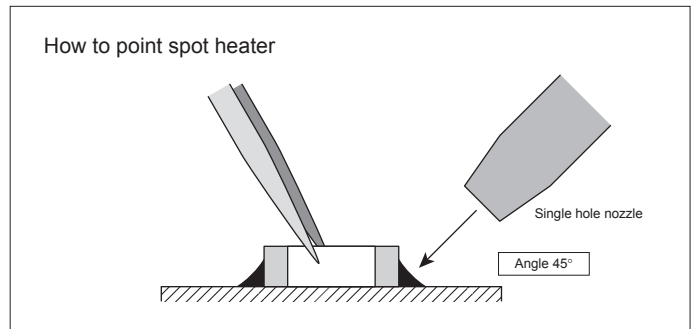

Soldering iron

- | | | |
|--------------------------------|-----------------------------|--|
| 1) Temperature of iron chip | 1206 and smaller 350°C max. | 5) Cautions |
| | 1210 and larger 280°C max. | a) Pre-heating is necessary rapid heating must be avoided.
Delta T ≤ 150°C (product size of bigger than 3.2×1.6mm. Delta T ≤ 130°C) |
| 2) Wattage | 80W max. | b) Avoid direct touching to capacitors. |
| 3) Tip shape of soldering iron | φ 3.0mm max. | c) Avoid rapid cooling after soldering. Natural cooling is recommended. |
| 4) Soldering Time | 3 sec. max. | *Consult as if it is difficult to keep the temperature 280°C max. for 1210 and larger MLCC'S. |

Precautions

Circuit Design

1. Once application and assembly environments have been checked, the capacitor may be used in conformance with the rating and performance which are provided in both the catalog and the specifications. Use exceeding that which is specified may result in inferior performance or cause a short, open, smoking, or flaming to occur, etc.
2. Please consult the manufacturer in advance when the capacitor is used in devices such as: devices which deal with human life, i.e. medical devices; devices which are highly public orientated; and devices which demand a high standard of liability. Accident or malfunction of devices such as medical devices, space equipment and devices having to do with atomic power could generate grave consequence with respect to human lives or, possibly, a portion of the public. Capacitors used in these devices may require high reliability design different from that of general purpose capacitors.
3. Please use the capacitors in conformance with the operating temperature provided in both the catalog and the specifications. Be especially cautious not to exceed the maximum temperature. In the situation the maximum temperature set forth in both the catalog and specifications is exceeded, the capacitor's insulation resistance may deteriorate, power may suddenly surge and short-circuit may occur. The capacitor has a loss, and may self-heat due to equivalent series resistance when alternating electric current is passed therethrough. As this effect becomes especially pronounced in high frequency circuits, please exercise caution. When using the capacitor in a (self-heating) circuit, please make sure the surface of the capacitor remains under the maximum temperature for usage. Also, please make certain temperature rises remain below 20°C .
4. Please keep voltage under the rated voltage which is applied to the capacitor. Also, please make certain the peak voltage remains below the rated voltage when AC voltage is super-imposed to the DC voltage. In the situation where AC or pulse voltage is employed, ensure average peak voltage does not exceed the rated voltage. Exceeding the rated voltage provided in both catalog and specifications may lead to defective withstanding voltage or, in worst case situations, may cause the capacitor to smoke or flame.
5. When the capacitor is to be employed in a circuit in which there is continuous application of a high frequency voltage or a steep pulse voltage, even though it is within the rated voltage, please inquire to the manufacturer. In the situation the capacitor is to be employed using a high frequency AC voltage or a extremely fast rising pulse voltage, even though it is within the rated voltage, it is possible capacitor reliability will deteriorate.
6. It is a common phenomenon of high-dielectric products to have a deteriorated amount of static electricity due to the application of DC voltage. Due caution is necessary as the degree of deterioration varies depending on the quality of capacitor materials, capacity, as well as the load voltage at the time of operation.
7. Do not use the capacitor in an environment where it might easily exceed the respective provisions concerning shock and vibration specified in the catalog and specifications. In addition, it is a common piezo phenomenon of high dielectric products to have some voltage due to vibration or to have noise due to voltage change. Please contact sales in such case.
8. If the electrostatic capacity value of the delivered capacitor is within the specified tolerance, please consider this when designing the respective product in order that the assembled product function appropriately.
9. Please contact us upon using conductive adhesives.

Storage

1. If the component is stored in minimal packaging (a heat-sealed or zippered plastic bag), the bag should be kept closed. Once the bag has been opened, reseal it or store it in a desiccator.
2. Keep storage place temperature + 5 to + 40 degree C, humidity 20 to 70% RH. See JIS C 60721-3-1, class 1K2 for other climatic conditions.
3. The storage atmosphere must be free of corrosive gas such as sulfur dioxide and chlorine. Also, avoid exposing the product to saline moisture. If the product is exposed to such atmospheres, the terminals will oxidize and solderability will be effected.
4. Precautions 1) to 3) apply to chip capacitors packaged in carrier tapes.
5. The solderability is assured for 6 months from our shipping date if the above storage precautions are followed.

Safety application guideline and detailed information of electrical properties are also provided in Kyocera web site;
URL: <https://global.kyocera.com/prdct/electro/>

General CM02 Series Size (JIS Code) : 01005(0402) # Packaging Code (Packaging quantity) : H(20,000pcs.) / N(80,000pcs.) / P(40,000pcs.)

Dielectric code C Δ	Part Number	Capacitance	□:Tolerance	Voltage [V]	Dimension			Q
					L[mm]	W[mm]	T[mm]	
CG/CH	CM02C Δ 1R0□25A#	1pF	B:±0.1pF / C:±0.25pF	25	0.4±0.02	0.2±0.02	0.2±0.02	420
	CM02C Δ 1R5□25A#	1.5pF	B:±0.1pF / C:±0.25pF					430
	CM02C Δ 2R0□25A#	2pF	B:±0.1pF / C:±0.25pF					440
	CM02C Δ 3R0□25A#	3pF	B:±0.1pF / C:±0.25pF					460
	CM02C Δ 4R0□25A#	4pF	B:±0.1pF / C:±0.25pF					480
	CM02C Δ 5R0□25A#	5pF	B:±0.1pF / C:±0.25pF					500
	CM02C Δ 6R0□25A#	6pF	C:±0.25pF / D:±0.5pF					520
	CM02C Δ 7R0□25A#	7pF	C:±0.25pF / D:±0.5pF					540
	CM02C Δ 8R0□25A#	8pF	C:±0.25pF / D:±0.5pF					560
	CM02C Δ 9R0□25A#	9pF	C:±0.25pF / D:±0.5pF					580
	CM02C Δ 100□25A#	10pF	J:±5% / K:±10%					600
	CM02C Δ 120□25A#	12pF	J:±5% / K:±10%					640
	CM02C Δ 150□25A#	15pF	J:±5% / K:±10%					700
	CM02C Δ 180□25A#	18pF	J:±5% / K:±10%					760
	CM02C Δ 220□25A#	22pF	J:±5% / K:±10%	840				
	CM02C Δ 270□16A#	27pF	J:±5% / K:±10%	940				
	CM02C Δ 330□16A#	33pF	J:±5% / K:±10%	1000				
	CM02C Δ 390□16A#	39pF	J:±5% / K:±10%					
	CM02C Δ 470□16A#	47pF	J:±5% / K:±10%					
	CM02C Δ 560□16A#	56pF	J:±5% / K:±10%					
	CM02C Δ 680□16A#	68pF	J:±5% / K:±10%					
	CM02C Δ 820□16A#	82pF	J:±5% / K:±10%					
CM02C Δ 101□16A#	100pF	J:±5% / K:±10%						
CM02C Δ 121□16A#	120pF	J:±5% / K:±10%						
CM02C Δ 151□16A#	150pF	J:±5% / K:±10%						
CM02C Δ 181□16A#	180pF	J:±5% / K:±10%						
CM02C Δ 221□16A#	220pF	J:±5% / K:±10%						

General CM03 Series Size (JIS Code) : 0201(0603) # Packaging Code (Packaging quantity) : H(15,000pcs.) / N(50,000pcs.) / Q(30,000pcs.) / W(150,000pcs.)

Dielectric code C Δ	Part Number	Capacitance	□:Tolerance	Voltage [V]	Dimension			Q
					L[mm]	W[mm]	T[mm]	
CG/CH	CM03C Δ 1R0□50A#	1pF	B:±0.1pF / C:±0.25pF	50	0.6±0.03	0.3±0.03	0.3±0.03	420
	CM03C Δ 1R5□50A#	1.5pF	B:±0.1pF / C:±0.25pF					430
	CM03C Δ 2R0□50A#	2pF	B:±0.1pF / C:±0.25pF					440
	CM03C Δ 3R0□50A#	3pF	B:±0.1pF / C:±0.25pF					460
	CM03C Δ 4R0□50A#	4pF	B:±0.1pF / C:±0.25pF					480
	CM03C Δ 5R0□50A#	5pF	B:±0.1pF / C:±0.25pF					500
	CM03C Δ 6R0□50A#	6pF	C:±0.25pF / D:±0.5pF					520
	CM03C Δ 7R0□50A#	7pF	C:±0.25pF / D:±0.5pF					540
	CM03C Δ 8R0□50A#	8pF	C:±0.25pF / D:±0.5pF					560
	CM03C Δ 9R0□50A#	9pF	C:±0.25pF / D:±0.5pF					580
	CM03C Δ 100□50A#	10pF	J:±5% / K:±10%					600
	CM03C Δ 120□50A#	12pF	J:±5% / K:±10%					640
	CM03C Δ 150□50A#	15pF	J:±5% / K:±10%					700
	CM03C Δ 180□50A#	18pF	J:±5% / K:±10%					760
	CM03C Δ 220□50A#	22pF	J:±5% / K:±10%	840				
	CM03C Δ 270□50A#	27pF	J:±5% / K:±10%	940				
	CM03C Δ 330□50A#	33pF	J:±5% / K:±10%	1000				
	CM03C Δ 390□50A#	39pF	J:±5% / K:±10%					
	CM03C Δ 470□50A#	47pF	J:±5% / K:±10%					
	CM03C Δ 560□50A#	56pF	J:±5% / K:±10%					
	CM03C Δ 680□50A#	68pF	J:±5% / K:±10%					
	CM03C Δ 820□50A#	82pF	J:±5% / K:±10%					
CM03C Δ 101□50A#	100pF	J:±5% / K:±10%						

General CM05 Series Size (JIS Code) : 0402(1005) # Packaging Code (Packaging quantity) : H(10,000pcs.) / N(50,000pcs.) / Q(20,000pcs.) / W(100,000pcs.)

Dielectric code C Δ	Part Number	Capacitance	□:Tolerance	Voltage [V]	Dimension			Q
					L[mm]	W[mm]	T[mm]	
CG/CH	CM05C Δ 121□50A#	120pF	J:±5% / K:±10%	50	1.0±0.05	0.5±0.05	0.5±0.05	1000
	CM05C Δ 151□50A#	150pF	J:±5% / K:±10%					
	CM05C Δ 181□50A#	180pF	J:±5% / K:±10%					
	CM05C Δ 221□50A#	220pF	J:±5% / K:±10%					
	CM05C Δ 271□50A#	270pF	J:±5% / K:±10%					
	CM05C Δ 331□50A#	330pF	J:±5% / K:±10%					
	CM05C Δ 391□50A#	390pF	J:±5% / K:±10%					
	CM05C Δ 471□50A#	470pF	J:±5% / K:±10%					

General CM105 Series Size (JIS Code) : 0603(1608) # Packaging Code (Packaging quantity) : T(4,000pcs.) / L(10,000pcs.)

Dielectric code C Δ	Part Number	Capacitance	□:Tolerance	Voltage [V]	Dimension			Q
					L[mm]	W[mm]	T[mm]	
CG/CH	CM105C Δ 561□50A#	560pF	J:±5% / K:±10%	50	1.6±0.10	0.8±0.10	0.8±0.10	1000
	CM105C Δ 681□50A#	680pF	J:±5% / K:±10%					
	CM105C Δ 821□50A#	820pF	J:±5% / K:±10%					
	CM105C Δ 102□50A#	1nF	J:±5% / K:±10%					



Part Number List



General CM02 Series Size (JIS Code) : 01005(0402) # Packaging Code (Packaging quantity) : H(20,000pcs.) / N(80,000pcs.) / P(40,000pcs.)

Dielectric code	Part Number	Capacitance	□:Tolerance	Voltage [V]	Dimension			Tan δ [%]
					L[mm]	W[mm]	T[mm]	
X5R	CM02X5R101□16A#	100pF	K:±10% / M:±20%	16	0.4±0.02	0.2±0.02	0.2±0.02	12.5
	CM02X5R151□16A#	150pF	K:±10% / M:±20%					
	CM02X5R221□16A#	220pF	K:±10% / M:±20%					
	CM02X5R331□16A#	330pF	K:±10% / M:±20%					
	CM02X5R471□16A#	470pF	K:±10% / M:±20%					
	CM02X5R681□16A#	680pF	K:±10% / M:±20%					
	CM02X5R102□16A#	1nF	K:±10% / M:±20%					
	CM02X5R152□16A#	1.5nF	K:±10% / M:±20%					
	CM02X5R222□16A#	2.2nF	K:±10% / M:±20%					
	CM02X5R332□16A#	3.3nF	K:±10% / M:±20%					
	CM02X5R472□16A#	4.7nF	K:±10% / M:±20%					
	CM02X5R682□16A#	6.8nF	K:±10% / M:±20%					
	CM02X5R103□16A#	10nF	K:±10% / M:±20%					
	CM02X5R153□06A#	15nF	K:±10% / M:±20%					
	CM02X5R223□06A#	22nF	K:±10% / M:±20%					
	CM02X5R333□06A#	33nF	K:±10% / M:±20%					
	CM02X5R473□06A#	47nF	K:±10% / M:±20%					
	CM02X5R683□06A#	68nF	K:±10% / M:±20%					
X7R	CM02X5R104□06A#	100nF	K:±10% / M:±20%	6.3	0.4±0.02	0.2±0.02	0.2±0.02	12.5
	CM02X5R224M06A#	220nF	M:±20%					
	CM02X5R474M06A#	470nF	M:±20%					
	CM02X7R101□16A#	100pF	K:±10% / M:±20%					
	CM02X7R151□16A#	150pF	K:±10% / M:±20%					
	CM02X7R221□16A#	220pF	K:±10% / M:±20%					
	CM02X7R331□16A#	330pF	K:±10% / M:±20%					
	CM02X7R471□16A#	470pF	K:±10% / M:±20%					
	CM02X7R681□16A#	680pF	K:±10% / M:±20%					
	CM02X7R102□16A#	1nF	K:±10% / M:±20%					
	CM02X7R152□16A#	1.5nF	K:±10% / M:±20%					
	CM02X7R222□16A#	2.2nF	K:±10% / M:±20%					

General CM03 Series Size (JIS Code) : 0201(0603) # Packaging Code (Packaging quantity) : H(15,000pcs.) / N(50,000pcs.) / Q(30,000pcs.) / W(150,000pcs.)

Dielectric code	Part Number	Capacitance	□:Tolerance	Voltage [V]	Dimension			Tan δ [%]					
					L[mm]	W[mm]	T[mm]						
X5R	CM03X5R151□25A#	150pF	K:±10% / M:±20%	25	0.6±0.03	0.3±0.03	0.3±0.03	5.0					
	CM03X5R221□25A#	220pF	K:±10% / M:±20%										
	CM03X5R331□25A#	330pF	K:±10% / M:±20%										
	CM03X5R471□25A#	470pF	K:±10% / M:±20%										
	CM03X5R681□25A#	680pF	K:±10% / M:±20%										
	CM03X5R102□25A#	1nF	K:±10% / M:±20%										
	CM03X5R152□25A#	1.5nF	K:±10% / M:±20%										
	CM03X5R222□25A#	2.2nF	K:±10% / M:±20%										
	CM03X5R332□25A#	3.3nF	K:±10% / M:±20%										
	CM03X5R472□25A#	4.7nF	K:±10% / M:±20%										
	CM03X5R682□25A#	6.8nF	K:±10% / M:±20%										
	CM03X5R103□25A#	10nF	K:±10% / M:±20%										
	CM03X5R153□10A#	15nF	K:±10% / M:±20%										
	CM03X5R223□10A#	22nF	K:±10% / M:±20%										
	CM03X5R333□10A#	33nF	K:±10% / M:±20%										
	CM03X5R473□10A#	47nF	K:±10% / M:±20%										
	CM03X5R683□10A#	68nF	K:±10% / M:±20%										
	CM03X5R104□10A#	100nF	K:±10% / M:±20%										
	CM03X5R224□10A#	220nF	K:±10% / M:±20%										
	CM03X5R474□06A#	470nF	K:±10% / M:±20%										
	CM03X5R105M16A#	1μF	M:±20%						6.3	0.6±0.03	0.3±0.03	0.3±0.03	12.5
	CM03X5R105M06A#								16	0.6±0.09	0.3±0.09	0.3±0.09	20.0
	CM03X5R225M10AH								6.3	0.6±0.05	0.3±0.05	0.3±0.05	12.5
	CM03X5R225M06AH	2.2μF	M:±20%						10	0.6±0.09	0.3±0.09	0.3±0.09	15.0
CM03X5R225M06A#035	6.3			0.6±0.09	0.3±0.09	0.3±0.09	12.5						
CM03X5R475M04AH	6.3			0.6±0.05	0.3±0.05	0.3±0.05	12.5						
CM03X7R151□25A#	4.7μF	M:±20%	4	0.6±0.09	0.3±0.09	0.3±0.09	12.5						
X7R	CM03X7R151□25A#	150pF	K:±10% / M:±20%	25	0.6±0.03	0.3±0.03	0.3±0.03	3.5					
	CM03X7R221□25A#	220pF	K:±10% / M:±20%										
	CM03X7R331□25A#	330pF	K:±10% / M:±20%										
	CM03X7R471□16A#	470pF	K:±10% / M:±20%										
	CM03X7R681□16A#	680pF	K:±10% / M:±20%										
	CM03X7R102□16A#	1nF	K:±10% / M:±20%										
	CM03X7R152□10A#	1.5nF	K:±10% / M:±20%										
	CM03X7R222□10A#	2.2nF	K:±10% / M:±20%										
	CM03X7R332□10A#	3.3nF	K:±10% / M:±20%										
	CM03X7R472□10A#	4.7nF	K:±10% / M:±20%										
	CM03X7R682□10A#	6.8nF	K:±10% / M:±20%										
	CM03X7R103□10A#	10nF	K:±10% / M:±20%										



Part Number List



General CM05 Series Size (JIS Code) : 0402(1005) # Packaging Code (Packaging quantity) : H(10,000pcs.) / N(50,000pcs.) / Q(20,000pcs.) / W(100,000pcs.)

Dielectric code	Part Number	Capacitance	□:Tolerance	Voltage [V]	Dimension			Tan δ [%]
					L[mm]	W[mm]	T[mm]	
X5R	CM05X5R104□25A#	100nF	K:±10% / M:±20%	25	1.0±0.05	0.5±0.05	0.5±0.05	5.0
	CM05X5R224□16A#	220nF	K:±10% / M:±20%	16	1.0±0.05	0.5±0.05	0.5±0.05	12.5
	CM05X5R474□10A#	470nF	K:±10% / M:±20%	10	1.0±0.05	0.5±0.05	0.5±0.05	12.5
	CM05X5R474□06A#			6.3	1.0±0.05	0.5±0.05	0.5±0.05	10.0
	CM05X5R105□35A#	1μF	K:±10% / M:±20%	35	1.0±0.05	0.5±0.05	0.5±0.05	10.0
	CM05X5R105□25A#			25				
	CM05X5R105□16A#			16				
	CM05X5R105□10A#			10				
	CM05X5R105□06A#			6.3				
	CM05X5R225□10A#			10				
	CM05X5R225□06A#	2.2μF	K:±10% / M:±20%	6.3	1.0±0.05	0.5±0.05	0.5±0.05	12.5
	CM05X5R475M16A#	4.7μF	M:±20%	16	1.0±0.20	0.5±0.20	0.5±0.20	12.5
	CM05X5R475M06A#			6.3	1.0±0.15	0.5±0.15	0.5±0.15	12.5
	CM05X5R106M06A#	10μF	M:±20%	6.3	1.0±0.20	0.5±0.20	0.5±0.20	12.5
	CM05X5R156M04A#	15μF	M:±20%	4	1.0±0.15	0.5±0.15	0.5±0.15	12.5
CM05X5R226M04A#	22μF	4		1.0±0.20	0.5±0.20	0.5±0.20		
X7R	CM05X7R104□25A#	100nF	K:±10% / M:±20%	25	1.0±0.05	0.5±0.05	0.5±0.05	12.5

General CM105 Series Size (JIS Code) : 0603(1608) # Packaging Code (Packaging quantity) : T(4,000pcs.) / L(10,000pcs.)

Dielectric code	Part Number	Capacitance	□:Tolerance	Voltage [V]	Dimension			Tan δ [%]
					L[mm]	W[mm]	T[mm]	
X5R	CM105X5R105□25A#	1μF	K:±10% / M:±20%	25	1.6±0.15	0.8±0.15	0.8±0.15	12.5
	CM105X5R225□16A#	2.2μF	K:±10% / M:±20%	16	1.6±0.10	0.8±0.10	0.8±0.10	12.5
	CM105X5R475□10A#	4.7μF	K:±10% / M:±20%	10	1.6±0.15	0.8±0.15	0.8±0.15	12.5
	CM105X5R475□06A#			6.3	1.6±0.15	0.8±0.15	0.8±0.15	7.5
	CM105X5R106M06A#	10μF	M:±20%	6.3	1.6±0.15	0.8±0.15	0.8±0.15	12.5
X7R	CM105X7R105□16A#	1μF	K:±10% / M:±20%	16	1.6±0.10	0.8±0.10	0.8±0.10	12.5
	CM105X7R105□10A#			10				
	CM105X7R225□06A#	2.2μF	K:±10% / M:±20%	6.3	1.6±0.15	0.8±0.15	0.8±0.15	12.5

General CM21 Series Size (JIS Code) : 0805(2012) # Packaging Code (Packaging quantity) : T(3,000pcs.) / L(10,000pcs.)

Dielectric code	Part Number	Capacitance	□:Tolerance	Voltage [V]	Dimension			Tan δ [%]
					L[mm]	W[mm]	T[mm]	
X5R	CM21X5R105□50A#	1μF	K:±10% / M:±20%	50	2.0±0.10	1.25±0.10	1.25±0.10	12.5
	CM21X5R105□25A#			25	2.0±0.10	1.25±0.10	1.25±0.10	5.0
	CM21X5R225□25A#	2.2μF	K:±10% / M:±20%	25	2.0±0.20	1.25±0.20	1.25±0.20	12.5
	CM21X5R225□16A#			16	2.0±0.10	1.25±0.10	1.25±0.10	5.0
	CM21X5R475□25A#	4.7μF	K:±10% / M:±20%	25	2.0±0.20	1.25±0.20	1.25±0.20	12.5
	CM21X5R475□16A#			16	2.0±0.15	1.25±0.15	1.25±0.15	12.5
	CM21X5R475□10A#	10μF	K:±10% / M:±20%	10	2.0±0.10	1.25±0.10	1.25±0.10	7.0
	CM21X5R106□16A#			16	2.0±0.20	1.25±0.20	1.25±0.20	12.5
CM21X5R106□06A#	6.3	2.0±0.20	1.25±0.20	1.25±0.20	7.5			
X7R	CM21X7R105□50A#	1μF	K:±10% / M:±20%	50	2.0±0.20	1.25±0.20	1.25±0.20	5.0
	CM21X7R105□25A#			25	2.0±0.10	1.25±0.10	1.25±0.10	12.5
	CM21X7R105□10A#	2.2μF	K:±10% / M:±20%	10	2.0±0.10	1.25±0.10	1.25±0.10	5.0
	CM21X7R225□25A#			25	2.0±0.20	1.25±0.20	1.25±0.20	12.5
	CM21X7R475□16A#	4.7μF	K:±10% / M:±20%	16	2.0±0.20	1.25±0.20	1.25±0.20	12.5
	CM21X7R106□10A#	10μF	K:±10% / M:±20%	10	2.0±0.20	1.25±0.20	1.25±0.20	12.5
	CM21X7R106□06A#			6.3				

General CM316 Series Size (JIS Code) : 1206(3216) # Packaging Code (Packaging quantity) : T(2,500pcs.) / L(5,000pcs.)

Dielectric code	Part Number	Capacitance	□:Tolerance	Voltage [V]	Dimension			Tan δ [%]
					L[mm]	W[mm]	T[mm]	
X5R	CM316X5R225□100A#	2.2μF	K:±10% / M:±20%	100	3.2±0.20	1.6±0.20	1.6±0.20	5.0
	CM316X5R225□25A#			25	3.2±0.20	1.6±0.15	1.6±0.15	5.0
	CM316X5R475□50A#	4.7μF	K:±10% / M:±20%	50	3.2±0.20	1.6±0.20	1.6±0.20	5.0
	CM316X5R475□25A#			25	3.2±0.20	1.6±0.15	1.6±0.15	5.0
	CM316X5R106□25A#	10μF	K:±10% / M:±20%	25	3.2±0.20	1.6±0.20	1.6±0.20	12.5
	CM316X5R106□16A#			16	3.2±0.20	1.6±0.15	1.6±0.15	5.0
	CM316X5R106□10A#	7.0	K:±10% / M:±20%	10	3.2±0.20	1.6±0.15	1.6±0.15	7.0
	CM316X5R226□16A#			16	3.2±0.20	1.6±0.20	1.6±0.20	12.5
	CM316X5R226□06A#	22μF	K:±10% / M:±20%	6.3	3.2±0.20	1.6±0.20	1.6±0.20	7.5
	CM316X7R475□50A#	4.7μF	K:±10% / M:±20%	50	3.2±0.20	1.6±0.20	1.6±0.20	5.0
CM316X7R475□25A#	25			3.2±0.20	1.6±0.20	1.6±0.20	12.5	
X7R	CM316X7R106□25A#	10μF	K:±10% / M:±20%	25	3.2±0.20	1.6±0.20	1.6±0.20	5.0
	CM316X7R106□16A#			16	3.2±0.20	1.6±0.20	1.6±0.20	12.5
	CM316X7R226□10A#	22μF	K:±10% / M:±20%	10	3.2±0.20	1.6±0.20	1.6±0.20	7.5
X7S	CM316X7R226□06A#	2.2μF	K:±10% / M:±20%	6.3	3.2±0.20	1.6±0.20	1.6±0.20	12.5
	CM316X7S225□100A#			100	3.2±0.20	1.6±0.20	1.6±0.20	5.0

General CM316 Series Size (JIS Code) : 1206(3216) # Packaging Code (Packaging quantity) : T(2,000pcs.)

Dielectric code	Part Number	Capacitance	□:Tolerance	Voltage [V]	Dimension			Tan δ [%]
					L[mm]	W[mm]	T[mm]	
X7S	CM316X7S475□100AT	4.7μF	K:±10% / M:±20%	100	3.2±0.30	1.6±0.30	1.6±0.30	5.0

General CM32 Series Size (JIS Code) : 1210(3225) # Packaging Code (Packaging quantity) : T(1,000pcs.) / L(4,000pcs.)

Dielectric code	Part Number	Capacitance	□:Tolerance	Voltage [V]	Dimension			Tan δ [%]
					L[mm]	W[mm]	T[mm]	
X5R	CM32X5R475□25A#	4.7μF	K:±10% / M:±20%	25	3.2±0.30	2.5±0.20	2.5±0.20	5.0
	CM32X5R106□50A#	10μF	K:±10% / M:±20%	50	3.2±0.30	2.5±0.20	2.5±0.20	5.0
	CM32X5R106□25A#			25	3.2±0.30	2.5±0.20	2.5±0.20	12.5
	CM32X5R106□16A#			16	3.2±0.30	2.5±0.20	2.5±0.20	5.0
	CM32X5R226□25A#			25	3.2±0.30	2.5±0.20	2.5±0.20	12.5
	CM32X5R226□16A#	22μF	K:±10% / M:±20%	16	3.2±0.30	2.5±0.20	2.5±0.20	5.0
	CM32X5R226□10A#			10	3.2±0.30	2.5±0.20	2.5±0.20	7.0
	CM32X5R476□06A#			6.3	3.2±0.30	2.5±0.20	2.5±0.20	7.5
CM32X7R475□16A#	4.7μF			K:±10% / M:±20%	16	3.2±0.30	2.5±0.20	2.5±0.20
X7R	CM32X7R106□50A#	10μF	K:±10% / M:±20%	50	3.2±0.30	2.5±0.20	2.5±0.20	5.0
	CM32X7R106□25A#			25	3.2±0.30	2.5±0.20	2.5±0.20	12.5
	CM32X7R226□16A#	22μF	K:±10% / M:±20%	16	3.2±0.30	2.5±0.20	2.5±0.20	12.5
	CM32X7R226□10A#			10	3.2±0.30	2.5±0.20	2.5±0.20	12.5

Low Profile CT03 Series Size (JIS Code) : 0201(0603) # Packaging Code (Packaging quantity) : H(15,000pcs.) / N(50,000pcs.) / Q(30,000pcs.) / N(150,000pcs.)

Dielectric code	Part Number	Capacitance	□:Tolerance	Voltage [V]	Dimension			Tan δ [%]
					L[mm]	W[mm]	T[mm]	
X5R	CT03X5R104□06A#022	100nF	K:±10% / M:±20%	6.3	0.6±0.03	0.3±0.03	0.22max	12.5
	CT03X5R105M06AH025	1μF	M:±20%	6.3	0.6±0.09	0.3±0.09	0.25max	12.5

Low Profile CT05 Series Size (JIS Code) : 0402(1005) # Packaging Code (Packaging quantity) : H(10,000pcs.) / N(50,000pcs.) / Q(20,000pcs.) / N(100,000pcs.)

Dielectric code	Part Number	Capacitance	□:Tolerance	Voltage [V]	Dimension			Tan δ [%]
					L[mm]	W[mm]	T[mm]	
X5R	CT05X5R105M06A#022	1μF	M:±20%	6.3	1.0±0.05	0.5±0.05	0.22max	12.5
	CT05X5R105□06A#033		K:±10% / M:±20%				0.33max	
	CT05X5R225M06A#033	2.2μF	M:±20%	6.3	1.0±0.05	0.5±0.05	0.33max	12.5
	CT05X5R475M06AH033	4.7μF	M:±20%	6.3	1.0±0.20	0.5±0.20	0.33max	15.0

Low Profile CT105 Series Size (JIS Code) : 0603(1608) # Packaging Code (Packaging quantity) : H(4,000pcs.) / N(10,000pcs.)

Dielectric code	Part Number	Capacitance	□:Tolerance	Voltage [V]	Dimension			Tan δ [%]
					L[mm]	W[mm]	T[mm]	
X5R	CT105X5R105□16A#055	1μF	K:±10%/M:±20%	16	1.6±0.10	0.8±0.10	0.55max	12.5

Low Profile CT21 Series Size (JIS Code) : 0805(2012) # Packaging Code (Packaging quantity) : H(4,000pcs.) / N(10,000pcs.)

Dielectric code	Part Number	Capacitance	□:Tolerance	Voltage [V]	Dimension			Tan δ [%]
					L[mm]	W[mm]	T[mm]	
X5R	CT21X5R105□25A#095	1μF	K:±10% / M:±20%	25	2.0±0.10	1.25±0.10	0.95max	5.0
	CT21X5R225□50A#095	2.2μF	K:±10% / M:±20%	50	2.0±0.20	1.25±0.20	0.95max	5.0
	CT21X5R475□16A#095	4.7μF	K:±10% / M:±20%	16	2.0±0.15	1.25±0.15	0.95max	12.5

High-Q CU02 Series Size (JIS Code) : 01005(0402) # Packaging Code (Packaging quantity) : H(20,000pcs.) / N(80,000pcs.) / P(40,000pcs.)

Dielectric code CΔ	Part Number	Capacitance	□:Tolerance	Voltage [V]	Dimension			Q
					L[mm]	W[mm]	T[mm]	
CG/CH	CU02CΔR20□16A#	0.2pF	B:±0.1pF / C:±0.25pF	16	0.4±0.02	0.2±0.02	0.2±0.02	404
	CU02CΔR50□16A#	0.5pF	B:±0.1pF / C:±0.25pF					410
	CU02CΔ1R0□16A#	1pF	B:±0.1pF / C:±0.25pF					420
	CU02CΔ1R5□16A#	1.5pF	B:±0.1pF / C:±0.25pF					430
	CU02CΔ2R0□16A#	2pF	B:±0.1pF / C:±0.25pF					440
	CU02CΔ3R0□16A#	3pF	B:±0.1pF / C:±0.25pF					460
	CU02CΔ4R0□16A#	4pF	B:±0.1pF / C:±0.25pF					480
	CU02CΔ5R0□16A#	5pF	B:±0.1pF / C:±0.25pF					500
	CU02CΔ6R0□16A#	6pF	C:±0.25pF / D:±0.5pF					520
	CU02CΔ7R0□16A#	7pF	C:±0.25pF / D:±0.5pF					540
	CU02CΔ8R0□16A#	8pF	C:±0.25pF / D:±0.5pF					560
	CU02CΔ9R0□16A#	9pF	C:±0.25pF / D:±0.5pF					580
	CU02CΔ100□16A#	10pF	J:±5% / K:±10%					600
	CU02CΔ120□16A#	12pF	J:±5% / K:±10%					640
	CU02CΔ150□16A#	15pF	J:±5% / K:±10%					700
	CU02CΔ180□16A#	18pF	J:±5% / K:±10%					760
	CU02CΔ220□16A#	22pF	J:±5% / K:±10%					840

Au Termination AT02 Series Size (JIS Code) : 01005(0402) Packaging Code (Packaging quantity) : H(20,000pcs.)
 ◇ Termination Code : G(AuSn solder and conductive adhesive.)

Dielectric code	Part Number	Capacitance	□:Tolerance	Voltage [V]	Dimension			Tan δ [%]
					L[mm]	W[mm]	T[mm]	
X5R	AT02X5R104□06GH	100nF	K:±10% / M:±20%	6.3	0.4±0.02	0.2±0.02	0.2±0.02	12.5

Au Termination AT03 Series Size (JIS Code) : 0201(0603) Packaging Code (Packaging quantity) : H(15,000pcs.)
 ◇ Termination Code : G (AuSn solder and conductive adhesive.) / K (Wire bonding and conductive adhesive.)

Dielectric code	Part Number	Capacitance	□:Tolerance	Voltage [V]	Dimension			Tan δ [%]
					L[mm]	W[mm]	T[mm]	
X5R	AT03X5R474□06◇H	470nF	K:±10% / M:±20%	6.3	0.6±0.03	0.3±0.03	0.3±0.03	12.5
	AT03X5R105□06◇H	1μF	K:±10% / M:±20%		0.6±0.05	0.3±0.05	0.3±0.05	
	AT03X5R225□06◇H	2.2μF	K:±10% / M:±20%		0.6±0.09	0.3±0.09	0.3±0.09	

Au Termination AT05 Series Size (JIS Code) : 0402(1005) Packaging Code (Packaging quantity) : H(10,000pcs.)
 ◇ Termination Code: G (AuSn solder and conductive adhesive.) / K (Wire bonding and conductive adhesive.)

Dielectric code	Part Number	Capacitance	□:Tolerance	Voltage [V]	Dimension			Tan δ [%]
					L[mm]	W[mm]	T[mm]	
X5R	AT05X5R474□06◇H	470nF	K:±10% / M:±20%	6.3	1.0±0.05	0.5±0.05	0.5±0.05	10.0
	AT05X5R105□06◇H	1μF	K:±10% / M:±20%					

Soft Termination ST03 Series Size (JIS Code) : 0201(0603) # Packaging Code (Packaging quantity) : H(15,000pcs.) / N(50,000pcs.) / Q(30,000pcs.) / W(150,000pcs.)

Dielectric code	Part Number	Capacitance	□:Tolerance	Voltage [V]	Dimension			Tan δ [%]
					L[mm]	W[mm]	T[mm]	
X5R	ST03X5R105M06S#	1μF	M:±20%	6.3	0.6±0.05	0.3±0.05	0.3±0.05	12.5
	ST03X5R225M04SH	2.2μF	M:±20%	4	0.6±0.10	0.3±0.10	0.3±0.10	12.5

Soft Termination ST05 Series Size (JIS Code) : 0402(1005) # Packaging Code (Packaging quantity) : H(10,000pcs.) / N(50,000pcs.) / Q(20,000pcs.)

Dielectric code	Part Number	Capacitance	□:Tolerance	Voltage [V]	Dimension			Tan δ [%]
					L[mm]	W[mm]	T[mm]	
X5R	ST05X5R225□10S#	2.2μF	K:±10% / M:±20%	10	1.0±0.07	0.5±0.07	0.5±0.07	12.5
	ST05X5R475M06S#	4.7μF	M:±20%	6.3	1.0±0.15	0.5±0.15	0.5±0.15	12.5
	ST05X5R106M06SH	10μF			1.0±0.20	0.5±0.20	0.5±0.20	

High Voltage CF21 Series Size (JIS Code) : 0805(2012) # Packaging Code (Packaging quantity) : T(4,000pcs.) / L(10,000pcs.)

Dielectric code	Part Number	Capacitance	□:Tolerance	Voltage [V]	Dimension			Tan δ [%]
					L[mm]	W[mm]	T[mm]	
X7R	CF21X7R221□250A#	220pF	K:±10% / M:±20%	250	2.0±0.10	1.25±0.10	0.85±0.10	2.5
	CF21X7R471□250A#	470pF	K:±10% / M:±20%					

High Voltage CF21 Series Size (JIS Code) : 0805(2012) # Packaging Code (Packaging quantity) : T(3,000pcs.) / L(10,000pcs.)

Dielectric code	Part Number	Capacitance	□:Tolerance	Voltage [V]	Dimension			Tan δ [%]
					L[mm]	W[mm]	T[mm]	
X7R	CF21X7R102□250A#	1nF	K:±10% / M:±20%	250	2.0±0.10	1.25±0.10	1.05±0.10	2.5
	CF21X7R222□250A#	2.2nF	K:±10% / M:±20%					
	CF21X7R472□250A#	4.7nF	K:±10% / M:±20%					
	CF21X7R103□250A#	10nF	K:±10% / M:±20%	250	2.0±0.10	1.25±0.10	1.25±0.10	2.5
	CF21X7R223□250A#	22nF	K:±10% / M:±20%					

High Voltage CF316 Series Size (JIS Code) : 1206(3216) # Packaging Code (Packaging quantity) : T(3,000pcs.) / L(10,000pcs.)

Dielectric code	Part Number	Capacitance	□:Tolerance	Voltage [V]	Dimension			Tan δ [%]
					L[mm]	W[mm]	T[mm]	
X7R	CF316X7R221□1000A#	220pF	K:±10% / M:±20%	1000	3.2±0.20	1.6±0.15	1.15±0.10	2.5
	CF316X7R471□1000A#	470pF					1.25±0.10	
	CF316X7R102□1000A#	1nF					1.25±0.10	
	CF316X7R222□630A#	2.2nF	K:±10% / M:±20%	630	3.2±0.20	1.6±0.15	1.25±0.10	2.5
	CF316X7R472□630A#	4.7nF						
	CF316X7R103□630A#	10nF						
	CF316X7R103□250A#	10nF	K:±10% / M:±20%	250	3.2±0.20	1.6±0.15	1.15±0.10	2.5
	CF316X7R223□250A#	22nF						



High Voltage CF316 Series Size (JIS Code) : 1206(3216) # Packaging Code (Packaging quantity) : T(2,500pcs.) / L(5,000pcs.)

Dielectric code	Part Number	Capacitance	□:Tolerance	Voltage [V]	Dimension			Tan δ [%]
					L[mm]	W[mm]	T[mm]	
X7R	CF316X7R222□1000A#	2.2nF	K:±10% / M:±20%	1000	3.2±0.20	1.6±0.15	1.6±0.15	2.5
	CF316X7R223□630A#	22nF		630	3.2±0.20	1.6±0.15	1.6±0.15	2.5
	CF316X7R473□250A#	47nF	K:±10% / M:±20%	250	3.2±0.20	1.6±0.15	1.6±0.15	2.5
	CF316X7R104□250A#	100nF						

High Voltage CF32 Series Size (JIS Code) : 1210(3225) # Packaging Code (Packaging quantity) : T(2,500pcs.) / L(5,000pcs.)

Dielectric code	Part Number	Capacitance	□:Tolerance	Voltage [V]	Dimension			Tan δ [%]
					L[mm]	W[mm]	T[mm]	
X7R	CF32X7R473□1000A#	4.7nF	K:±10% / M:±20%	1000	3.2±0.30	2.5±0.20	1.6±0.15	2.5
	CF32X7R223□630A#	22nF		630	3.2±0.30	2.5±0.20	1.6±0.15	2.5

High Voltage CF32 Series Size (JIS Code) : 1210(3225) # Packaging Code (Packaging quantity) : T(2,000pcs.) / L(5,000pcs.)

Dielectric code	Part Number	Capacitance	□:Tolerance	Voltage [V]	Dimension			Tan δ [%]
					L[mm]	W[mm]	T[mm]	
X7R	CF32X7R473□630A#	4.7nF	K:±10% / M:±20%	630	3.2±0.30	2.5±0.20	2.0±0.20	2.5
	CF32X7R104□250A#	100nF		250	3.2±0.30	2.5±0.20	2.0±0.20	2.5

High Voltage CF42 Series Size (JIS Code) : 1808(4520) Packaging Code (Packaging quantity) : T(2,000pcs.)

Dielectric code	Part Number	Capacitance	□:Tolerance	Voltage [V]	Dimension			Tan δ [%]
					L[mm]	W[mm]	T[mm]	
X7R	CF42X7R102□2000AT	1nF	K:±10% / M:±20%	2000	4.5±0.20	2.0±0.20	2.2 max	2.5
	CF42X7R222□1000AT	2.2nF	K:±10% / M:±20%	1000	4.5±0.20	2.0±0.20	2.2 max	2.5
	CF42X7R472□1000AT	4.7nF	K:±10% / M:±20%					
	CF42X7R103□1000AT	10nF	K:±10% / M:±20%					

High Voltage CF43 Series Size (JIS Code) : 1812(4532) Packaging Code (Packaging quantity) : T(500pcs.)

Dielectric code	Part Number	Capacitance	□:Tolerance	Voltage [V]	Dimension			Tan δ [%]
					L[mm]	W[mm]	T[mm]	
X7R	CF43X7R222□2000AT	2.2nF	K:±10% / M:±20%	2000	4.5±0.30	3.2±0.20	2.5 max	2.5
	CF43X7R223□1000AT	22nF	K:±10% / M:±20%	1000	4.5±0.30	3.2±0.20	2.5 max	2.5
	CF43X7R104□630AT	100nF	K:±10% / M:±20%	630	4.5±0.30	3.2±0.20	2.5 max	2.5
	CF43X7R224□250AT	220nF	K:±10% / M:±20%	250	4.5±0.30	3.2±0.20	2.5 max	2.5

Three Terminal Capacitors KNH05 Series Size (JIS Code) : 0402(1005) Packaging Code (Packaging quantity) : H(10,000pcs.)

Dielectric code	Part Number	Capacitance	□:Tolerance	Voltage [V]	Dimension			Tan δ [%]
					L[mm]	W[mm]	T[mm]	
X5R	KNH05X5R435M04AH	4.3μF	M:±20%	4	1.0±0.10	0.5±0.20	0.50 max	—
	KNH05X5R106M04AH	10μF	M:±20%		1.0±0.20	0.5±0.20	0.5±0.20	

Notes for Using the Catalog

1. Specifications described in this catalog are for references. Products specifications shall be based on written documents agreed by each party.
2. Contents in this catalog are subject to change without notice. It is recommended to confirm the latest information at the time of usage. Also, Kyocera Electronic Components Catalog is revised once a year. We may not be able to accept requests based on old catalogs.
3. Products in this catalog are intended to be used in general electronic equipment such as office equipment, audio and visual equipment, communication equipment, measurement instrument and home appliances. It is absolutely recommended to consult with our sales representatives in advance upon planning to use our products in applications which require extremely high quality and reliability such as aircraft and aerospace equipment, traffic systems, safety systems, power plant and medical equipment including life maintenance systems.
4. Even though we strive for improvements of quality and reliability of products, it is requested to design with enough safety margin in equipment or systems in order not to threaten human lives directly or damage human bodies or properties by an accidental result of products.
5. It is requested to design based on guaranteed specifications for such as maximum ratings, operating voltage and operating temperature. It is not the scope of our guarantee for unsatisfactory results due to misuse or inadequate usage of products in the catalog.
6. Operation summaries and circuit examples in this catalog are intended to explain typical operation and usage of the product. It is recommended to perform circuit and assembly design considering surrounding conditions upon using products in this catalog.
7. Technical information described in this catalog is meant to explain typical operations and applications of products, and it is not intended to guarantee or license intellectual properties or other industrial rights of the third party or Kyocera.
8. Trademarks, logos and brand names used in this catalog are owned by Kyocera or the corresponding third party.
9. Certain products in this catalog are subject to the Foreign Exchange and Foreign Trade Control Act of Japan, and require the license from Japanese Government upon exporting the restricted products and technical information under the law.
Besides, it is requested not to use products and technical information in the catalog for the development and/or manufacture of weapons of mass destruction or other conventional weapons, nor to provide them to any third party with the possibility of having such purposes.
10. It is prohibited to reprint and reproduce a part or whole of this catalog without permission.
11. Contents described herein are as of February 2018.

Design Tool Introduction



Search ceramic capacitors by parameters.

<http://prdct-search.kyocera.co.jp/electro-mlcc-en/>



