

# High Voltage Connector System

## SPD8 90° Male Connector 25mm<sup>2</sup>



Yazaki is a trusted automotive components supplier providing electrical distribution systems for over 80 years, including more than 25 years' experience supplying High Voltage (HV) components products toward the advancements of today's EV's.

Our SPD8 connector systems delivers a robust, cost effective and reliable solution in a compact size.

Important design advantages include:

- 90° and 180° Design Options
- Anti-Cross Thread Bolt Design
- Damage Resistant Housings
- Engine Vibration

### Product Characteristics

Positions	2
Cable Size	25mm <sup>2</sup>
Cable Type	Individually Shielded ISO
HVIL	Shunt
Handling Manual	YPES-15-1832E
Drawing	7285-1096-0W:R
Mating Header	7385-1134-51

# High Voltage Connector System

## SPD8 90° Male Connector 25mm<sup>2</sup>

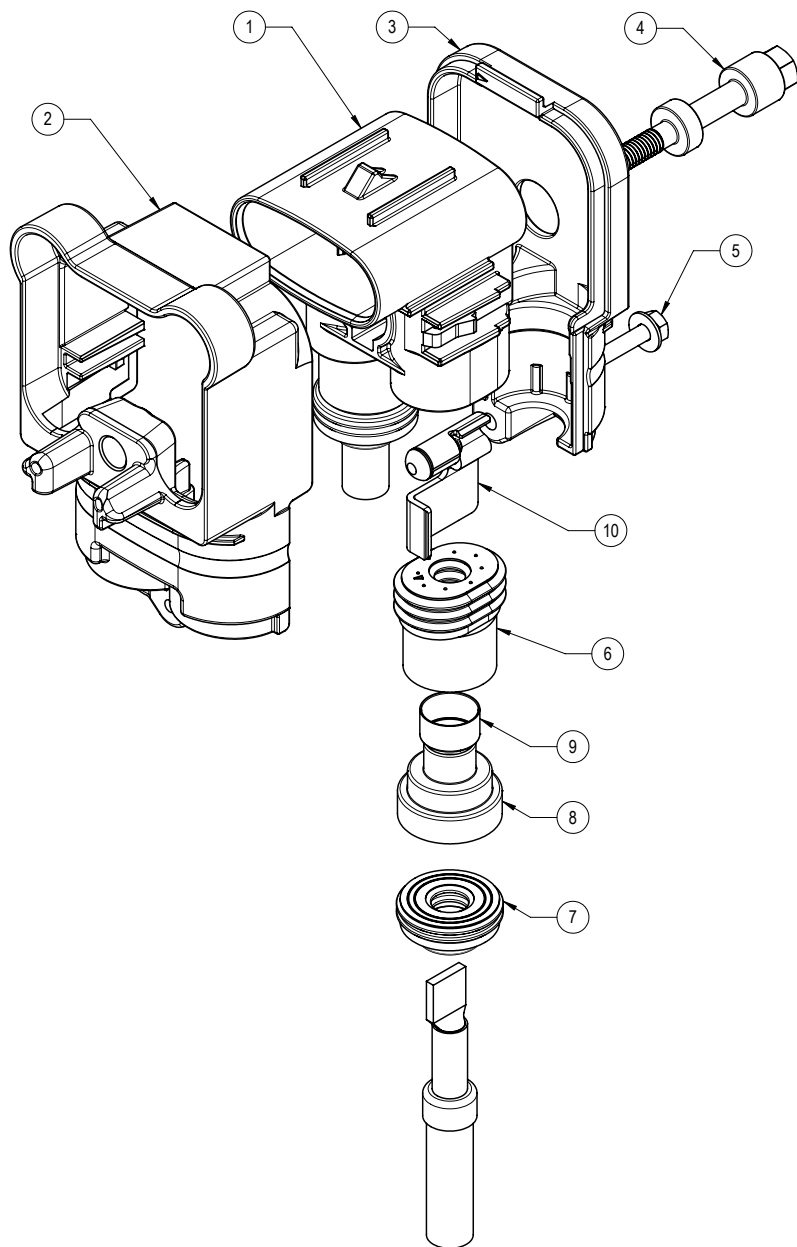

Item	Part Number - 25mm <sup>2</sup>	Description	Qty
1	7285-1328	Connector Sub-Assembly	1
2	7185-6060	Bottom Shield Shell	1
3	7185-6063	Top Shield Shell	1
4	7150-9024-03	M6 Bolt	1
5	7150-1540-0W	M4 X 18 Split Washer	1
6	7172-6151-70	Wire Seal	2
7	7172-5666-50	Rear Seal	2
8	7185-0498-02	Shield Terminal	2
9	7185-0700	Shield Sleeve	2
10	7285-0162-06	Male Terminal Assembly	2

### DISCLAIMER

TO THE MAXIMUM ALLOWED BY APPLICABLE LAWS, THE MANUFACTURER GIVES NO WARRANTY, EXPRESS OR IMPLIED, AS TO DESCRIPTION, QUALITY, MERCHANTABILITY, FITNESS FOR ANY PARTICULAR PURPOSE, PRODUCTIVENESS, OR ANY OTHER MATTER WITH REGARD TO THIS PRODUCT. THE INFORMATION CONTAINED HEREIN IS BASED ON MANUFACTURER KNOWLEDGE, HOWEVER, IT IS NOT GUARANTEED THAT SUCH INFORMATION IS ERROR-FREE. MANUFACTURER RESERVES THE RIGHT TO MAKE CHANGES ON THE INFORMATION PERTAINING TO THE PRODUCT WITHOUT FURTHER NOTICE.

### CONTACT

**Andre Guanco** - Product Manger HV  
[andre.guanco@us.yazaki.com](mailto:andre.guanco@us.yazaki.com)  
 Yazaki North America  
 6801 North Haggerty Road  
 Canton MI 48187 | USA  
 Phone: (1) 734.412.7447