

HD421, Pt Temperature Sensor according to DIN EN 60751

Temperature range -70 °C to +850 °C

- Large operation window up to 850 °C
- High accuracy over a wide temperature range
- High vibration and shock resistance
- Optimized for welding and brazing

HD 421 Pt-RTDs are characterized by long-term stability, precision over a broad temperature range and compatibility. HD421 elements are used to monitor high temperature processes in Energy&Power generation, PetroChemistry and others. In principle, the products can also be used in automotive applications, in this case YAGEO Nexensos will check upon the request of the customer, whether additional requirements can be met (e.g. IMDS, PPAP).

Nominal Resistance R_0 [Ω]	Tolerance Class	Order Number	Packaging
Pt100	F 0.6 (2B)	32208228	Slide blister

The measuring point for the nominal resistance is 4 mm from the end of the sensor body.

Temperature Range of Tolerance Class

Validity of Class F 0.6 (2B) -70 °C to +850 °C

Explanation:

Tolerance F 0.3 (B) -70 °C to +650 °C

Tolerance F 0.6 (2B) +650 °C to +850 °C

Temperature Coefficient

TCR = 3850 ppm/K

Response Time

Water ($v = 0.4$ m/s):
 $t_{0.5} = 0.05$ s
 $t_{0.9} = 0.17$ s

Air ($v = 2$ m/s):
 $t_{0.5} = 3.3$ s
 $t_{0.9} = 13$ s

Measuring Current

Pt100 Ω : -70 °C to 20 °C max. 1 mA,
 above 20 °C max. 1 mA
 (self-heating has to be considered)

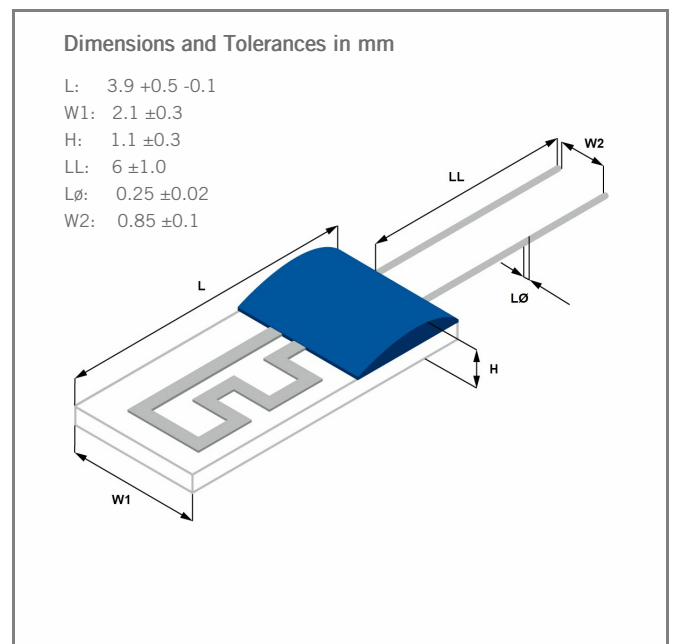

Image for illustration purposes only
 Color, shape and forming of fixing drop may vary

HD421, Pt Temperature Sensor according to DIN EN 60751

Temperature range -70 °C to +850 °C

Long-Term Stability

Ro-drift < then the allowed deviation according to DIN F 0.3 (B) after 1000 hours at 850 °C (energized, open)

Ro-drift < then the allowed deviation according to DIN F 0.3 (B) after 1000 hours at 650 °C (under current as clean MI-type)

Self-Heating

0.2 K/mW at 0 °C

Insulation Resistance

> 100 MΩ at 20 °C

> 2 MΩ at 650 °C

Vibration Resistance

Depends on installation

Shock Resistance

Depends on installation

Connection Technology

Welding, Brazing

Lead Type

Platinum

Tensile Strength of Leads

≥ 9 N

Packaging

Slide blister

Alternative packaging forms on request

Storage Life

Min. 12 months (in original packaging)

Note

Other tolerances, values of resistance and wire lengths are available on request.

Due to random sample measurements, a bending of connection wires may occur (called V-shape). This bending is batch-dependent and has no influence on the functionality of the platinum measuring resistor.



The information provided in this data sheet describes certain technical characteristics of the product, but shall not be qualified or construed as quality guarantee (Beschaffenheitsgarantie) in the meaning of sections 443 and 444 German Civil Code. The information provided in this data sheet regarding measurement values (including, but not limited to, response time, long-term stability, vibration and shock resistance, insulation resistance and self-heating) are average values that have been obtained under laboratory conditions in tests of large numbers of the product. Product results or measurements achieved by customer or any other person in any production, test, or other environment may vary depending on the specific conditions of use.

The customer is solely responsible to determine whether the product is suited for the customer's intended use; in this respect YAGEO Nexensos cannot assume any liability. The sale of any products by YAGEO Nexensos is exclusively subject to the General Terms of Sale and Delivery of YAGEO Nexensos in their current version at the time of purchase, which is available under www.yageo-nexensos.com/tc or may be furnished upon request. This data sheet is subject to changes without prior notice.

YAGEO Nexensos GmbH, Reinhard-Heraeus-Ring 23, 63801 Kleinostheim, Germany