

Clip Mount Power Resistor Thick Film Technology

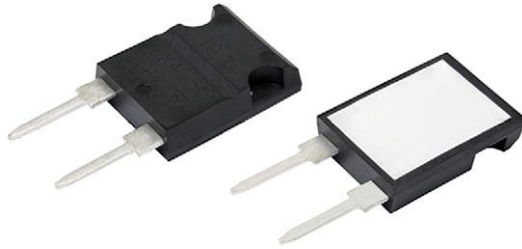

LTO150 are the extension of LTO series. The component is used in direct contact with heatsink. Fixation done by clip.

FEATURES

- 150 W at 45 °C case temperature heatsink mounted
- Direct mounting ceramic on heatsink
- Broad resistance range: 0.03 Ω to 1.3 MΩ
- Non inductive
- TO-247 package: compact and easy to mount
- Designed for clip mounting
- UL 94 V-0 material used - Compliant with EN45545-2
- **AEC-Q200 qualified**
- Material categorization: for definitions of compliance please see www.vishay.com/doc?99912



RoHS
COMPLIANT

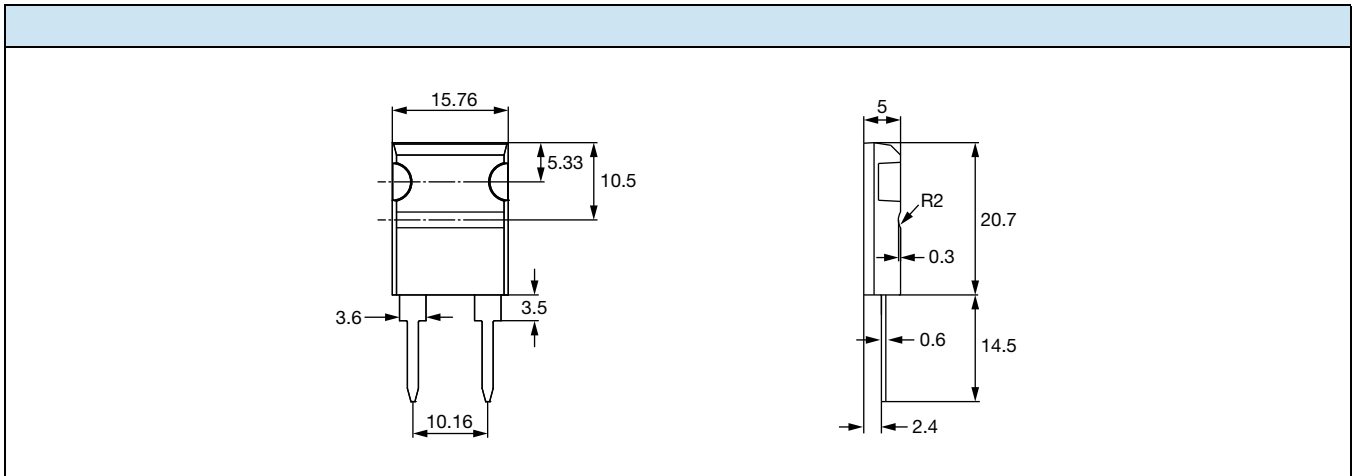

Note

- Tolerances unless stated: ± 0.3 mm

STANDARD ELECTRICAL SPECIFICATIONS

MODEL	SIZE	RESISTANCE RANGE Ω	RATED POWER $P_{25\text{ °C}}$ W	LIMITING ELEMENT VOLTAGE U_L V	TOLERANCE ± %	TEMPERATURE COEFFICIENT ± ppm/°C	CRITICAL RESISTANCE Ω
LTO 150	TO-247	0.03 to 1.3M	150	500	1, 2, 5, 10	200, 350, 900	1.66K

MECHANICAL SPECIFICATIONS

Mechanical Protection	Molded
Resistive Element	Thick film
Substrate	Alumina
Connections	Tinned copper
Weight	4 g max.
Clip Assembly Force	60 N to 110 N

ENVIRONMENTAL SPECIFICATIONS

Temperature Range	-55 °C to +175 °C
Climatic Category	55 / 175 / 56
Flammability	IEC 60695-11-5 2 applications 30 s separated by 60 s

TECHNICAL SPECIFICATIONS

Dissipation and Associated	Onto a heatsink + clip
Power Rating and Thermal Resistance of the Component	150 W at +45 °C (case temp.) $R_{TH(j-c)}$: 0.87 °C/W Free air: 4.5 W at +25 °C
Temperature Coefficient	See Performance table ± 200 ppm/°C
Dielectric Strength IEC 60115-1	3000 V_{RMS} - 1 min 10 mA max.
Insulation Resistance	≥ 10 ⁴ MΩ
Inductance	≤ 0.1 μH



PERFORMANCE		
TESTS	CONDITIONS	REQUIREMENTS
Momentary Overload	IEC 60115-1 1.5 Pr/5 s $U_S < 1.5 U_L$	$\pm (0.5 \% + 0.005 \Omega)$
Load Life	IEC 60115-1 1000 h Pr (free air) at +25 °C 90/30	$\pm (1 \% + 0.005 \Omega)$
High Temperature Exposure	AEC-Q200 REV D conditions: MIL-STD-202 method 108 1000 h, +175 °C, unpowered	$\pm (0.5 \% + 0.005 \Omega)$
Temperature Cycling	AEC-Q200 REV D conditions: JESD22 method JA-104 1000 cycles, -55 °C to +125 °C dwell time -15 min	$\pm (1 \% + 0.005 \Omega)$
Biased Humidity	AEC-Q200 REV D conditions: MIL-STD-202 method 103 1000 h, 85 °C, 85 % RH (10 % of free air power)	$\pm (1 \% + 0.005 \Omega)$
Operational Life	AEC-Q200 REV D conditions: MIL-STD-202 method 108 1000 h, 90/30, powered (free air) at +125 °C	$\pm (1 \% + 0.005 \Omega)$
ESD Human Body Model	AEC-Q200 REV D conditions: AEC-Q200-002 IEC 61000-4-2 25 kV _{AD}	$\pm (0.5 \% + 0.005 \Omega)$
Vibration	AEC-Q200 REV D conditions: MIL-STD-202 method 204 5 g's for 20 min, 12 cycles test from 10 Hz to 2000 Hz	$\pm (0.5 \% + 0.005 \Omega)$
Mechanical Shock	AEC-Q200 REV D conditions: MIL-STD-202 method 213 100 g's, 6 ms, 3.75 m/s 3 shocks/direction	$\pm (0.5 \% + 0.005 \Omega)$
Terminal Strength	AEC-Q200 REV D conditions: AEC-Q200-006 2 kgf, 60 sec	$\pm (0.25 \% + 0.01 \Omega)$

SPECIAL FEATURES			
Resistance Values	≥ 0.015	≥ 0.1	> 20
Tolerances	$\pm 1 \%$ at $\pm 10 \%$		
Typical Temperature Coefficient (-55 °C to +175 °C)	± 900 ppm/°C	± 350 ppm/°C	± 200 ppm/°C

CHOICE OF THE HEATSINK

The user must choose according to the working conditions of the component (power, room temperature).

Maximum working temperature must not exceed 175 °C. The dissipated power is simply calculated by the following ratio:

$$P = \frac{\Delta T}{[R_{TH(j-c)}] + [R_{TH(c-h)}] + [R_{TH(h-a)}]} \quad (1)$$

P: Expressed in W

ΔT : Difference between maximum working temperature and room temperature

$R_{TH(j-c)}$: Thermal resistance value measured between resistive layer and outer side of the resistor. It is the thermal resistance of the component.

$R_{TH(c-h)}$: Thermal resistance value measured between outer side of the resistor and upper side of the heatsink. This is the thermal resistance of the interface (grease, thermal pad), and the quality of the fastening device.

$R_{TH(h-a)}$: Thermal resistance of the heatsink

Example:

$R_{TH(c-h)} + R_{TH(h-a)}$ for LTO 150 power rating 10 W at ambient temperature +25 °C

Thermal resistance $R_{TH(j-c)}$: 0.87 °C/W

Considering equation (1) we have:

$$\Delta T = 175 \text{ °C} - 25 \text{ °C} = 150 \text{ °C}$$

$$R_{TH(j-c)} + R_{TH(c-h)} + R_{TH(h-a)} = \frac{\Delta T}{P} = \frac{150}{10} = 15 \text{ °C/W}$$

$$R_{TH(c-h)} + R_{TH(h-a)} = 15 \text{ °C/W} - 0.87 \text{ °C/W} = 14.13 \text{ °C/W}$$

Example with a thermal grease $R_{TH(c-h)} = 0.5 \text{ °C/W}$, we need a heatsink with $R_{TH(h-a)} = 13.63 \text{ °C/W}$



	CONFIGURATION 1	CONFIGURATION 2	CONFIGURATION 3
Power Dissipation (W)	150	35	26
T° Resistive Element (°C)	175	175	175
R _{TH(j-c)} Max. (°C/W)	0.87	0.87	0.87
R _{TH(c-h)} Typ. (°C/W)	0.127	0.33	0.33
R _{TH(h-a)} Max. (°C/W)	0.069	3.09	4.57
Fluid T° (°C)	15 (water)	25 (air)	25 (air)

CONFIGURATION 1: Water cooling heatsink CP15 from Lytron (304 mm x 95.3 mm x 8 mm) with water flow rate 4 LPM and thermal grease Bluesil Past 340 from BlueStar silicones. MAX08NG from AAVID screwed clip mounting.

CONFIGURATION 2: Air cooling heatsink 0S552 from AAVID (48 mm x 80 mm x 70 mm) and thermal grease Bluesil Past 340 from BlueStar silicones. MAX03HNG from AAVID clipped mounting.

CONFIGURATION 3: Air cooling heatsink 0S550 from AAVID (31.75 mm x 58.7 mm x 70 mm) and thermal grease Bluesil Past 340 from BlueStar silicones. MAX03HNG from AAVID clipped mounting.

MOMENTARY OVERLOAD

In any case the applied voltage must be lower than the maximum overload voltage of 750 V during 5 s.

ENERGY CURVE (SINGLE PULSE)

The values indicated on the graph below are applicable to resistors in air or mounted onto a heatsink.

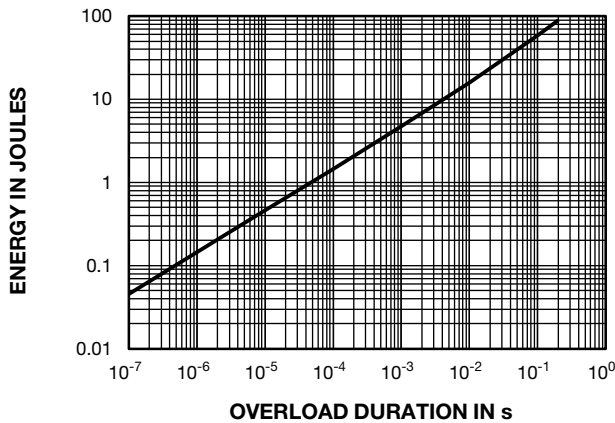

POWER CURVE

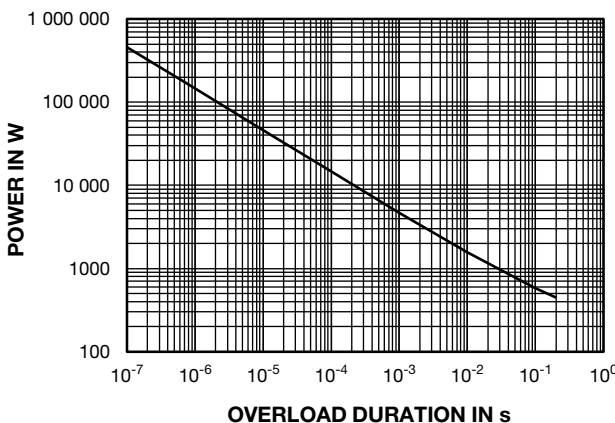

POWER RATING

The temperature of the case should be maintained within the limits specified.

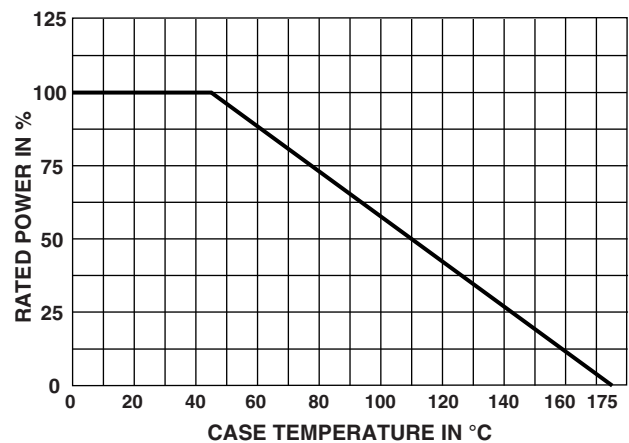

PACKAGING

Tube of 30 units

MARKING

Model, style, resistance value (in Ω), tolerance (in %), manufacturing date, Vishay Sfernice trademark according IEC 60062.

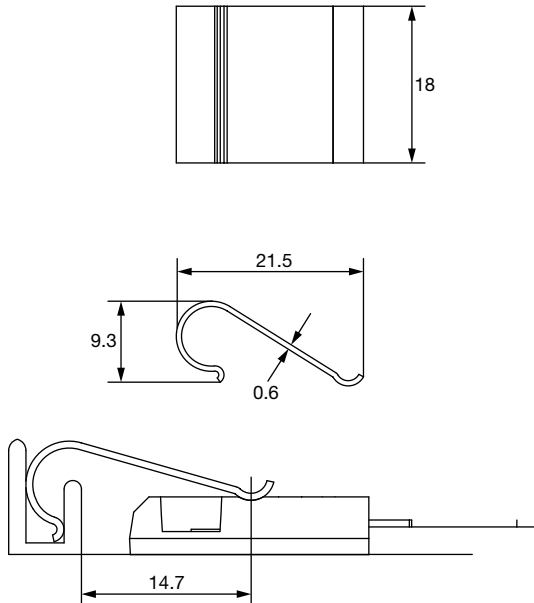
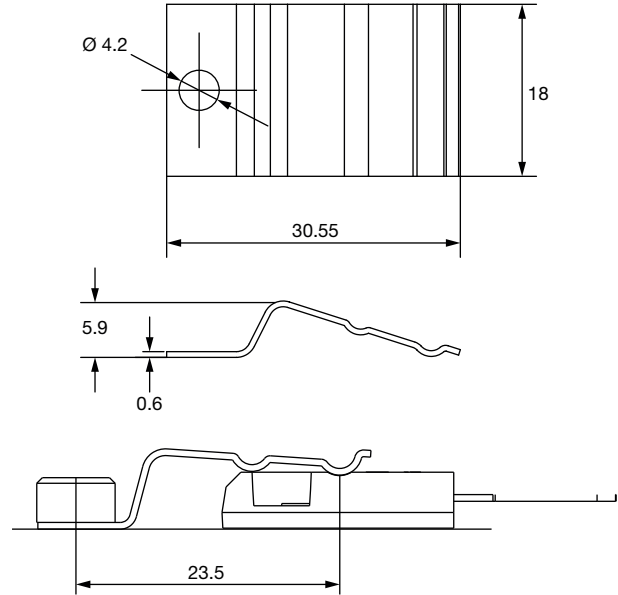
CLIPS
ACCRFLTO150CL (MAX03HNG)

ACCRFLTO150VS (MAX08NG)

CLIP MOUNTING RECOMMENDATION

To improve the thermal conductivity, all surface of ceramic has to be coated with a thermal silicon grease. If you not use our clipped or screwed clip, it is recommended that a mounting force of 60 N to 110 N be applied to the center of the molding case of the component. Tightening torque 2 Nm when mounting screwed clip MAX08NG on heatsink.

ORDERING INFORMATION

LTO	150	F	2.7 kΩ	$\pm 1\%$	xxx	TU30	e3
MODEL	STYLE	CONNECTIONS	RESISTANCE VALUE	TOLERANCE	CUSTOM DESIGN	PACKAGING	LEAD (Pb)-FREE
				$\pm 1\%$ $\pm 2\%$ $\pm 5\%$ $\pm 10\%$	Optional on request: special TCR, shape etc.		

GLOBAL PART NUMBER INFORMATION

L	T	O	1	5	0	F	2	7	0	0	0	J	T	E	3
GLOBAL MODEL	SIZE	LEADS	OHMIC VALUE				TOLERANCE	PACKAGING	LEAD (Pb)-FREE						
LTO	150	F = radial leads	The first four digits are significant figures and the last digit specifies the number of zeros to follow. R designates decimal point. 48R70 = 48.7 Ω 48701 = 48 700 Ω 10002 = 100 000 Ω R0100 = 0.01 Ω R4700 = 0.47 Ω 27000 = 2700 Ω = 2.7 k Ω				F = 1 % G = 2 % J = 5 % K = 10 %	T = tube Tube 30 pieces	E3 = pure tin						

CLIP PART NUMBER INFORMATION

REFERENCE	PART NUMBER FOR ORDERING
Screwed clip MAX08NG	ACCRFLTO150VS
Clipped clip MAX03HNG	ACCRFLTO150CL

Mouser Electronics

Authorized Distributor

Click to View Pricing, Inventory, Delivery & Lifecycle Information:

[Vishay:](#)

[LTO150F220R0JTE3](#) [LTO150F1R000JTE3](#) [LTO150FR4700JTE3](#) [LTO150F10R00JTE3](#) [ACLLTO150VS](#)
[LTO150F10000JTE3](#) [LTO150F100R0JTE3](#) [LTO150F4R700JTE3](#) [LTO150F22000JTE3](#) [LTO150FR1000JTE3](#)
[LTO150F470R0JTE3](#) [LTO150F47R00JTE3](#) [LTO150F22R00JTE3](#) [LTO150F2R200JTE3](#) [ACLLTO150CL](#)