



SEMI-AUTOMATIC BENCH TOP CRIMPING SOLUTIONS

A COMPLETE TERMINATOR OVERVIEW

Understanding Your Termination Solution Options

Know your wire size

Many TE Connectivity bench top presses (terminators) share the same quality and performance features.

Selecting the right terminator platform for your wire harness needs starts with understanding what size wire you plan to crimp. Small wire sizes require less crimp force, but benefit largely from wire guides, and crimp quality monitoring to help maintain proper termination.

Conversely, larger wire sizes require more crimp force and in some cases the need to process loose-piece terminals.

Once you know what you plan to crimp our expert sales and engineering teams can guide you to the right solution based on your specific crimp requirements and cost considerations.

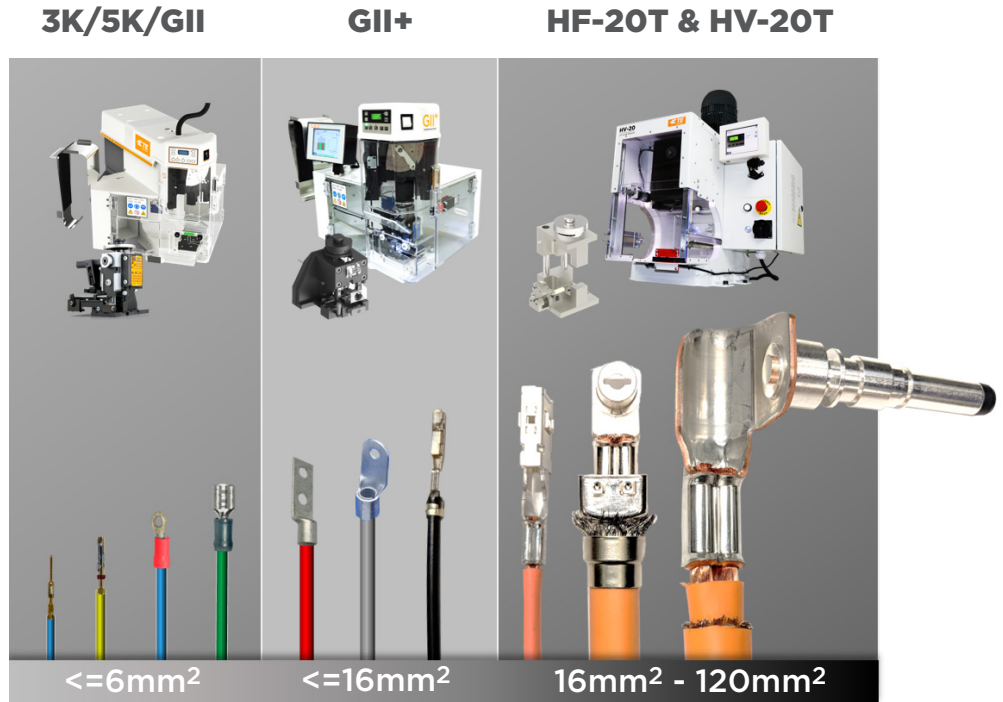

3K/5K Terminators

- Capable of 3,000 or 5,000 lbs of crimp force
- Priced competitively
- 30 & 40 mm stroke available
- Available with and without crimp quality monitoring (CQM II)
- CE approved



GII Terminator

- Capable of 5,000 lbs of crimp force
- Improved interior lighting vs 3K/5K platform
- 40 mm stroke only
- Available with and without CQM II module
- Quieter than 3K/5K terminators
- Recommended for customers who have tape fed applications
- Split-cycle comes standard
- CE approved

Understanding Your Termination Solution Options



GII+ Terminator

- Capable of 10,000 lbs of crimp force
- 30 & 40 MM stroke available
- Available with and without CQM II module
- Capable of processing strip & loose piece terminals
- CE approved



HF-20 Terminator

- Capable of 40,000 lbs of crimp force
- 44 mm stroke only
- Capable of processing up to 120 mm² wire
- CE approved



HV-20 Terminator

- Capable of 40,000 lbs of crimp force
- 44 mm stroke only
- Includes CQM II module
- Capable of processing up to 120 mm² wire
- CE approved



Standard & Inverted Splice Terminators

- Capable of crimping two or more stranded or magnet wires with a combined circular mil area of 400 - 13,000
- Designed to handle pig-tail and splice terminals
- Available with and without CQM II module
- CE approved

AMP 3K/40, 5K/30 & 5K/40 Terminators

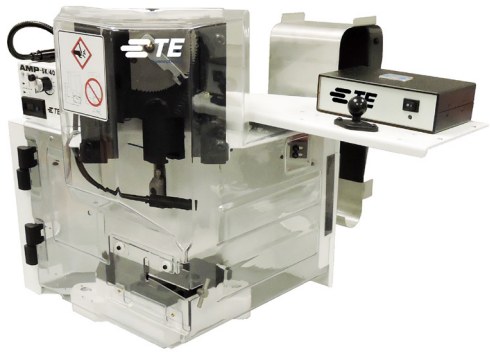

AMP 5K/40 Wire Processing Machine Shown

Specifications

Customer Manual: 409-10204

Crimp Force:

AMP 3/K-40 max. 1.361 kg [3,000 lb.] capable of crimping 0.03-2.5 mm² [32-14 AWG]

AMP 5K/40 max. 2.268 kg [5,000 lb.] capable of crimping 0.03-8.0 mm² [32-10 AWG]

Electrical: 100-240 V, 50/60 Hz, single-phase
Operating current is 3 amps

*Note: Customer must supply power cord and final connection

Air: 620-760 kPa [90-100 psi], 2.83 l/s (6 scfm) (Please refer to application logs for specific air requirements)

Dimensions (without terminal reel and reel support)

Weight: 77.3 kg [170.4 lb.]

Height: 585 mm [23 in.] without reel supports

Width: 536 mm [21.1 in.]

Depth: 521 mm [20.5 in.]

Ordering information

Description	Stroke	Baseplate	Part #
AMP 3K/40 CE EL Terminator	40 MM	AMP Style	2161400-5
AMP 5K/30 CE Universal Jam Terminator	30 MM	Universal Jam	2-2161500-1
AMP 5K/30 CE Universal Jam (W/ CQM II)	30 MM	Universal Jam	2-2161500-2
AMP 5K/40 CE Terminator	40 MM	AMP Style	2161500-1
AMP 5K/40 CE Terminator (W/ CQM II)	40 MM	AMP Style	2161500-2
AMP 5K/30 CE Terminator	30 MM	AMP Style	3-2161500-1
AMP 5K/30 CE Terminator (W/ CQM II)	30 MM	AMP Style	3-2161500-2
AMP 5K/40 CE Terminator (W/ Oversized Guard, AF)	40 MM	AMP Style	4-2161500-0
AMP 5K/40 CE Thru-Splice Terminator	40 MM	Thru Splice	2161300-1
AMP 5K/40 CE Thru-Splice Terminator (W/ CQM II)	40 MM	Thru Splice	2161300-2
AMP 5K/40 CE (W/ Strip Module)	40 MM	AMP Style	2161700-4
AMP 5K/40 CE (W/ Strip Module and CQM II)	40 MM	AMP Style	2161700-5
AMP 5K/40 CE Terminator (W/CQM II & Defective Crimp Cut Module)	40 MM	AMP Style	2362229-1
AMP 5K/30 CE Universal Jam (W/CQM II & Defective Crimp Cut Module)	30 MM	AMP Style	2362229-2

Features

AMP 3K/40 and 5K/40 terminators use a DC motor with gearbox drive. The result is a small-footprint design that is fast and quiet.

Cycle time is less than 0.4 seconds with an operation sound level of 76 dB(A).

Standard features such as tool-less precision crimp height adjust, CQM capability, batch counter and a work light are integral parts of serial equipment.

By offering options the AMP 5K/40 terminator can be tailored to the specific application requirements without inflating the price for unwanted features.

The AMP 3K/40 5K/40 terminator is CE approved.

Standard equipment (5K/40 models only)

- Tool-less precision crimp height adjustment
- Manual shut height adjustment
- Batch counter
- Work light
- Tool-less removal/exchange of applicators
- Jog capability
- Assembled with metric hardware

Optional equipment (5K/40 models only)

- Pneumatic feed
- Crimp Quality Monitor (CQM II)
- Oiler kit

AMP-O-LECTRIC GII Terminator



GII Wire Processing Machine for Crimp Terminals

Specifications

Customer Manual - 409-32035

Crimp Force: 2,268 kg [5,000 lb.] maximum crimp force capable of crimping 0.03-8.0 mm² [32-10 AWG]

Air: Pneumatic 620-760 kPa [90-100 psi] for models with air feed applicators and/or stripper module.

Electrical: 100-240 VAC, ± 10% AC, 50/60 Hz, Single phase. Operating current is 3 amps

*Note: Customer must supply power cord and final connection

Dimensions (without terminal reel and reel support)

Weight: Approx. 104 kg [230 lb.]

Height: 520.7 mm [20.5"]

Depth: 546.1 mm [21.5"]

Width: 553.7 mm [21.8"]

Safety first

Improved guarding on the GII terminator provides open access for quick and smooth installation of both end-feed and side-feed applicator styles and meets applicable CE and domestic safety requirements.

Engineered with the operator in mind

The GII is one of the quietest terminators on the market. It features improved access to, and significantly updated lighting in the under cabinet and target areas, and includes a variable speed option which gives the operator more flexibility for those tricky applications that benefit from slower ram and feed speeds. And, with its tool-less changeover capability, setup is both quick and easy.

Precision matters

All GII terminators include precision adjustment for crimp height — an important feature, which, in combination with the optional Crimp Quality Monitor (CQM II), enables repeatable, tight crimp tolerances required for today's demands for higher levels of quality. By simply resetting a dial, the operator can adjust crimp height in 0.013 mm [.0005"] increments over a 0.457 mm [.018"] range.

Complete control

Our user-friendly LCD control panel includes simple button controls for: motor powering on and off, adjusting the ram speed, jogging the motor forward or in reverse, switching to split-cycle operation, work lighting, air feed, and batch counter reset. For improved quality, the controls also detect and report errors in the machine and stop cycling when a bad crimp is detected by the CQM II.

Ordering Information

Description	Stroke	Baseplate	Part #
GII CE Terminator	40 MM	AMP Style	2217000-1
GII CE Terminator (W/CQM II)	40 MM	AMP Style	2217000-2
GII CE Terminator (W/Stripping Module)	40 MM	AMP Style	2217001-3
GII CE Terminator (W/Stripping Module and CQM II)	40 MM	AMP Style	2217001-4
GII CE Thru-Splice Terminator	40 MM	Thru-Splice	2217002-1
GII CE Thru-Splice Terminator (W/CQM II)	40 MM	Thru-Splice	2217002-2
GII CE Terminator (W/CQM II & Defective Crimp Cut Module)	40 MM	Thru-Splice	2362229-3
GII CE Loose Piece Terminator	40 MM	AMP Style	2374600-1
GII CE Loose Piece Terminator (W/CQM II)	40 MM	AMP Style	2374600-2

AMP-O-LECTRIC GII+ Terminator



GII+ Wire Processing Machine

Specifications

Customer Manual - 409-32035

Crimp Force: 4,537 kg [10,000 lb.] max.

Air: Pneumatic 620-760 kPa [90-100 psi] for models w/ air-feed applicators. (Please refer to application logs for specific air requirements)

Electrical: 208-240 VAC, 50/60 Hz, Single-Phase
Operating current is 5 amps

*Note: Customer must supply power cord and final connection

Dimensions (without terminal reel and reel support)

Weight: Approx. 116 kg [255 lb.]

Height: 520.7 mm [20.5"]

Depth: 635.2 mm [25"]

Width: 624.3 mm [24.5"]

Ordering Information

Description	Part #	Applicator Type	Guard Insert	Existing Applicator Upgrade Kit	Standard Equipment
Base model Base model w/CQM	2844800-1	Mid-Size, Side Feed Mid-Size, End Feed	2844807-1 (Shipped w/ Machine)	Not Required	Air Feed Kit 2217339-1
	2844800-2	Mid-Size, Side Feed Mid-Size, End Feed w/Wire Seals	2844808-1	Not Required	
		OCEAN, Side Feed OCEAN, End Feed	2844817-1	Not Required	
Loose Piece Loose Piece w/CQM	2844810-1	Mid-Size, Loose Piece	2844813-1 (Shipped w/ Machine)	2844832-1	-
	2844810-2	Mini-Size, Loose Piece	2844814-1	2844827-1	-
Thru-Splice Thru-Splice w/CQM	2844820-1	Mid-Size, Through-Splice Side-Feed	-	2844831-1	Air Feed Kit 2217339-1
	2844820-2	Mini-Size Through-Splice End-Feed	-	2844825-1	
Base model, Pacific Base model w/ CQM II, Pacific	2-2844800-1	OCEAN Pacific, Side Feed OCEAN Pacific, End Feed	2844817-1	Not Required	Air Feed Kit 2217339-1
	2-2844800-2				

Engineered for up to 16mm² wire sizes

The GII+ terminator combines all the features of the popular GII line with the power to handle larger diameter wire sizes.

Complete control

The user-friendly Crimp Quality II (CQM II) control panel includes simple button controls for: motor powering on and off, adjusting the ram speed, jogging the motor forward or in reverse, switching to split-cycle operation, work lighting, air feed, and batch counter reset. For improved quality, the controls also detect and report errors in the machine and stop cycling when a bad crimp is detected by the CQM II.

Precision matters

All GII+ terminators include precision adjustment for crimp height — an important feature, which, in combination with the optional CQM II, enables repeatable, tight crimp tolerances required for today's demands for higher levels of quality. By simply resetting a dial, the operator can adjust crimp height in 0.013 mm [.0005"] increments over a 0.457 mm [.018"] range.

Engineered with the operator in mind

The GII+ utilizes strong LED lighting in the under cabinet and target areas to improve operator visibility. The standard variable-speed option gives the operator more flexibility for those tricky applications that benefit from slower ram and feed speeds. And, with its tool-less changeover capability, setup is both quick and easy.

HF-20T & HV-20T Terminators



HV-20T & HF-20T Wire Processing Machines

Specifications

Crimp Force: 18,144 kg [40,000 lb.] max.

Air: Pneumatic 620-760 kPa [90-100 psi]

Electrical: 208-240 VAC, 50/60 Hz, Three-Phase
Operating current is 4kW

Dimensions

Weight: Approx. 637 kg [1,404 lb.]

Height: 974 mm [38"]

Depth: 777 mm [30.5"]

Width: 552 mm [22"]

Engineered for high voltage applications

The HF-20T and HV-20T are robust, compact, high force bench top machines capable of terminating cables up to 120mm²

Both models are eccentric presses capable of reaching 178kN (20 tons) of crimp force, with fast, repeatable accuracy. The HV-20 model comes with a CQM II digital interface for crimp force monitoring, variable speed and an integrated vacuum system to keep sensitive connections clean and clear of debris commonly associated with high voltage cable processing.

Flexible design

To best fit the application process, the flexible design of the high force machines accommodates multiple processing orientations. The adjustable die holder platform can be easily rotated to handle processing from the left, front or right side of the unit. Side feed guarding is also available for all models to accommodate both loose piece and reeled terminal applications.

Safe, easy operation

Both models offer a simple push button design with multiple interlock features to confirm operator safety throughout the crimping process.



Combining sophisticated controls, traceability system and equipped with ethernet and USB ports, the HV-20T and HF-20T bench-top terminators are Industry 4.0 ready.



The integrated vacuum system design keeps sensitive connections clean and clear of debris commonly associated with high voltage cable crimping.

Ordering Information

Description	w/Loose Piece Guarding	w/Side Feed Guarding (for reeled terminals)
HF-20T, High Force Terminator, 400V	2335500-1	2359697-1
HF-20T, High Force Terminator, 200V	2335500-2	2358697-2
HV-20T, High Voltage Terminator, 400V	2348822-1	2358698-1
HV-20T, High Voltage Terminator, 200V	2348822-2	2358698-2

Thru-Splice, Pigtail Splice Standard and Inverted Terminators

Multiple versions available



Inverted Splice Terminator & Applicator

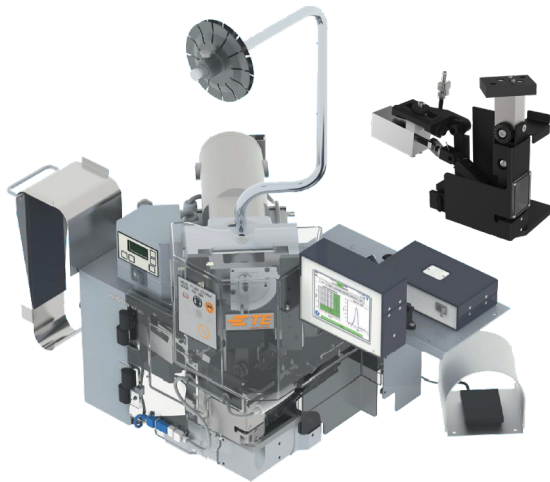

Standard Splice Terminator & Applicator

Specifications

Crimp Force: 2,268 kg [5,000 lb.] max.

Air: Pneumatic 620-760 kPa [90-100 psi] for models w/air-feed applicators (Please refer to application logs for specific air requirements)

Electrical: 208-240 VAC, 50/60 Hz, Single Phase
Operating current is 5 amps

*Note: Customer must supply power cord and final connection

Dimensions (without terminal reel and reel support)

Weight: 77.3 kg [170.4 lb.]

Height: 585 mm [23 in.] without reel supports

Width: 536 mm [21.1 in.]

Depth: 521 mm [20.5 in.]

TE standard splice terminators are offered in multiple versions, for both pigtail or thru-splices (with front and rear operator access), and can come with or without crimp quality monitoring (CQM II). When equipped with the CQM II, force and position can be measured during every crimp cycle, providing real-time monitoring of crimp height, the fundamental crimp characteristic, as well as the shape of the work curve for every termination. Standard Splice terminators do not accept heavy-duty mini (HDM), heavy-duty industrial (HDI) and OCEAN applicators.

If even better access to present wires to the crimping area is needed, the Inverted Splice Terminator (IST) provides more flexibility when terminating leads from completed motor assemblies. When using the pig-tail applicator, operators can cut excess wire using the integrated shear in the applicator, thereby keeping leads as small as possible (short break out). The shorter leads provide added flexibility to post process magnet wire applications. Operators can more easily tuck in or heat shrink terminated lead ends, allowing for potentially smaller motor housings.

Ordering Information

Description		Part #
Inverted Pig-tail Splice	Inverted AMP Applicator with Specialized Terminator	2305750-1
	Inverted AMP Applicator with Specialized Terminator (w/CQM II)	2305750-2
	Inverted AMP Applicator Only*	2305750-3
	Inverted AMP Applicator Spare Parts Kit	7-2305750-7
	Inverted AMP Applicator with Specialized Terminator	2335336-1
	Inverted AMP Applicator with Specialized Terminator (w/CQM II)	2335336-2
	Inverted AMP Applicator Only	2335336-3
	Inverted AMP Applicator Spare Parts Kit	7-2335336-7
Inverted Thru-Splice	Applicator with Specialized Terminator	2326072-1
	Applicator with Specialized Terminator (w/CQM II)	2326072-2
	Applicator Only*	2326072-3
	Applicator Spare Parts Kit	7-2326072-7
	Applicator with Specialized Terminator	2335350-1
	Applicator with Specialized Terminator (w/CQM II)	2335350-2
	Applicator Only*	2335350-3
	Applicator Spare Parts Kit	7-2335350-7
Standard Splice	AMP 5K/40 Splice terminator w/Manual Crimp Adjustment	2161300-1
	AMP 5K/40 Splice terminator w/Manual Crimp Adjustment (w/CQM II)	2161300-2
	GII CE Thru-Splice Terminator	2217002-1
	GII CE Thru-Splice Terminator (w/CQM II)	2217002-2

Terminator Options

Capacitive start sensor

A retrofittable capacitive start sensor is available for 5K/40 terminators with stripping modules.

Description	Part #
Capacitive start sensor	2844876-2

Short strip blades

Short strip blades for stripping down to 1.5 mm strip length are available for 5K/40 terminators with stripping modules.

Description	Part #
Short strip blades	2217860-1

Defective crimp cut

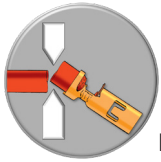

With the help of our CQM II, defective crimp cut technology can immediately detect when a bad crimp occurs and cut off the crimped terminal to keep bad crimps from accidentally passing to the next step in your wire harness manufacturing. Defective crimp cut enabled terminators are available on select 5K and GII terminators.

Description	Part #
5K atlantic terminator (w/defective crimp cut module)	2362229-1
5K pacific terminator (w/defective crimp cut module)	2362229-2
GII CE terminator (W/CQM II & defective crimp cut module)	2362229-3

Guard insert part numbers

Description	Part #	Dimensions	
		A	B
Standard (away from the applicator)	354529-2	7.80 mm [.307 in.]	6.35 mm [.250 in.]
Standard (close to the applicator) shipped with the machine	1-679532-0	6.22 mm [.245 in.]	5.08 mm [.200 in.]
Near tape	679994-2	6.35 mm [.250 in.]	6.35 mm [.250 in.]
Away from tape	679995-2	8.74 mm [.344 in.]	6.35 mm [.250 in.]

Optional Stripping Module

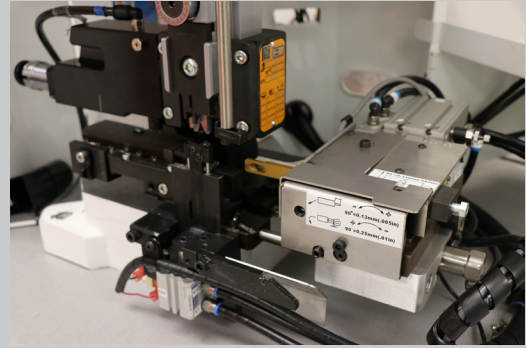

- For end- and side-feed applicators
- 3 modes of operation (Crimp only, strip only, or strip & crimp)
- Foot-switch or sensor activated
- Fast applicator changeover and easy adjustments
- Step mode for fast set-up
- Air blast ejects slugs into a collecting tray
- Compatible with crimp quality monitor

Base plate

- The base plate with stripping unit as an option provides the mounting surface on which the applicator is installed.
- The applicator can be installed and removed with a long allen key.

Tape guard insert

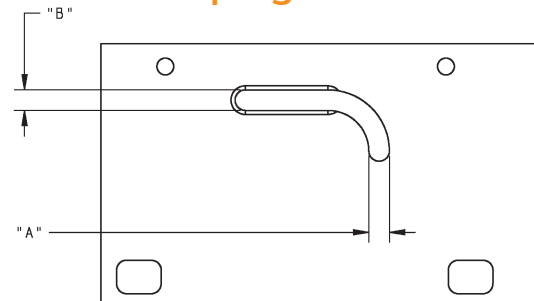

Standard guard insert

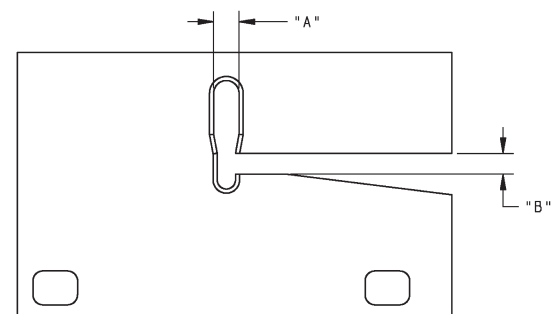

Note: Some applications require the installation of an oversized guard kit 1976900-1. These applications are primarily ones that use two inch stroke air-feed cylinders.

Terminator Options

Crimp height adjustment using precision adjustment mechanism



- Detent stops in the mechanism to adjust the crimp height
- Indexing the mechanism in either direction
- Change the crimp height in increments of approx. 0.013 mm [.0005 in.] per step
- Electric located in the ram linkage

You can adjust the crimp height by moving the precision adjustment lever

- To the right to increase the crimp height or
- To the left to decrease the crimp height

Airfeed valve assembly

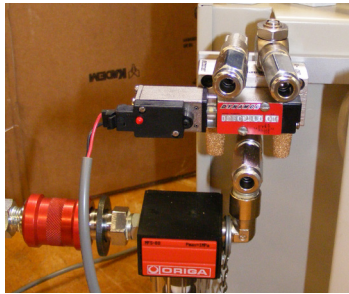

Description	Part #	Purpose
Air feed valve kit	2161209-1	Required to run applicators
Lubricator bowl assembly	2119955-1 (Side Feed) 219955-2 (End Feed) 2119955-5 (Side Feed, Rear Carrier)	Pre-lubricates the strip
Shoulder eye bolt	2362229-3	Provides a lift point for machine installation

Gauges



Compatible with TE Connectivity and commercially available crimping presses, using quick changes style applicators.

Applicator gauge

Suitable instrument to provide correct positioning of all TE applicators

- Simple installation and use

Alignment gauge

528440-5

Control panel



Decrease Speed

Decreases the motor speed for normal cycle operation and for jogging



Increase Speed

Increases the motor speed for normal cycle operation and for jogging



Error Reset

Clears the displayed error code



Count Reset

Clears the batch count to 0



Jog

Causes the DC motor to rotate at the jog speed set by the increase/decrease speed

Terminator Options

Crimp Quality Monitor (CQM II)

When used on TE terminators the CQM II provides a complete crimp detection analysis. It checks every crimp as it is produced, measuring crimp height of each termination and evaluating the quality of each crimp. If a crimp has questionable characteristics, visual and audible alarms alert the operator. The CQM II includes data ports for printing and networking.

CQM II offers five different crimp analysis methods.

1. Crimp height
2. Work index
3. Peak force
4. Fast Fourier Transform (FFT)
5. Point-to-point

Features

- Best measurement to check compliance with crimp design
- Real time measurement during crimp cycle
- Inspects 100% of terminations
- Crimp height measurement accuracy: +/-0.012 mm
- Data can be saved to a USB flash drive
- 5 unique analysis methods capable of detecting most crimp faults.

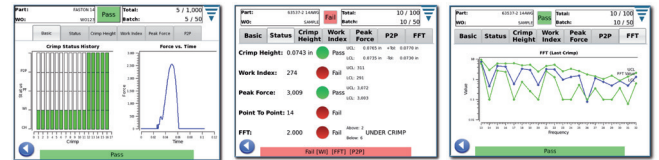

Operation Setup of CQM

- Simple set-up and operation through task-bar selections.
- The system walks the user through all necessary tasks required to start production.

Ordering information for CQM II kits

Description	Part #
AMP 5K/40 Terminator	2161670-1
AMP 5K/40 Terminator (w/ Stripping Module)	2161670-2
AMP 5K/30 Terminator (CQM II kit available for the 3K 30 mm stroke machine)	2161670-3
GII Terminator	2217288-1
GII Terminator (w/ Stripping Module)	2217288-2



Let's Connect

Learn more about our comprehensive line of tooling solutions at tooling.te.com.

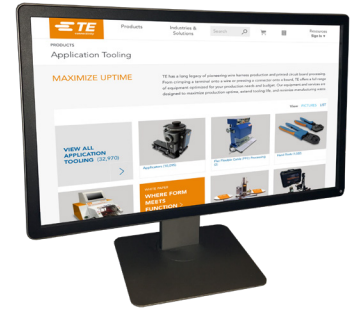

TE Connectivity Technical Support Center

USA:
1.800.522.6752

Latin/S. America
+55 11 3404 6261

France:
+33.1.34.20.8686

Canada:
1.800.522.6752

Germany:
+49.6151.607.1999

Netherlands:
+31.73.624.6999

Mexico:
+52.55.11.06.0800

UK:
+44.0800.267666

China:
+86.400.820.6015

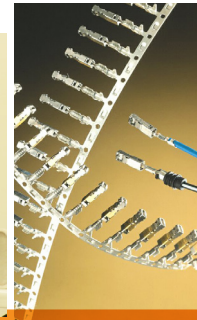

te.com

OCEAN, AMP, AMP 3/K-40, AMP 5K/40, TE Connectivity and the TE connectivity (logo) are trademarks. All other logos, products and/or company names referred to herein might be trademarks of their respective owners. The information given herein, including drawings, illustrations and schematics which are intended for illustration purposes only, is believed to be reliable. However, TE Connectivity makes no warranties as to its accuracy or completeness and disclaims any liability in connection with its use. TE Connectivity's obligations shall only be as set forth in TE Connectivity's Standard Terms and Conditions of Sale for this product and in no case will TE Connectivity be liable for any incidental, indirect or consequential damages arising out of the sale, resale, use or misuse of the product. Users of TE Connectivity products should make their own evaluation to determine the suitability of each such product for the specific application.

© 2020 TE Connectivity Ltd. family of companies All Rights Reserved.

2338133-1 08/20

Contact us today to learn more

E-mail (Americas): fieldservicesnorthamerica@te.com

Phone (Americas): 800-722-1111 or 717-986-3434

E-mail (EMEA): TEFE1@te.com

Phone (EMEA): +49-6151-607-1518

For additional information download catalog no. 1-1307619-0 from tooling.te.com.

www.te.com

