

SEACON

ALL-WET

UNDERWATER ELECTRICAL WET-MATE CONNECTORS



S E A C O N



ALL-WET ROUND SERIES

UNDERWATER ELECTRICAL WET-MATE CONNECTORS

SECTION	PAGE
Product News	AW 3
Introduction	AW 4
Availability	AW 4
Applications	AW 4
Special Assemblies	AW 4
 ALL-WET ROUND SERIES	
Part Number System	AW 4
General Information	AW 5
Ampacity Chart for Standard Parts	AW 5
Standard Wiring Color Code	AW 5
 Dimension Details:	
AW-P-BC	AW 6
AW-S-BC	AW 6
AW-MP	AW 7
AW-FS	AW 7
AW-P-BC with Ground (w/G)	AW 8
AW-S-BC with Ground (w/G)	AW 8
AW-MP with Ground (w/G)	AW 9
AW-FS with Ground (w/G)	AW 9
Standard In-Line w/Ground Color Code	AW 9
Locking Sleeves (FLS/MLS)	AW 10
Interface Details	AW 11
Contact Configurations	AW 12
 ALL-WET SPLIT SERIES	
General Information	AW 14
Ampacity Chart for Standard Parts	AW 14
Standard Wiring Color Code	AW 14
Part Number System	AW 14
 Dimension Details:	
AW-MP-SPLIT	AW 15
AW-S-BC	AW 15
Contact Configurations	AW 16
 ALL-WET FLAT SERIES SECTION	
General Information	AW 18
Ampacity Chart for Standard Parts	AW 18
Standard Wiring Color Code	AW 18
Part Number System	AW 18
 Dimension Details:	
FAW-P-BC-R/A	AW 19
FAW-S-BC-R/A	AW 19
FAW-P-MP	AW 20
FAW-S-MP	AW 20
FAW-P-FS	AW 21
FAW-S-FS	AW 21
MAW-2-HC w/IN2 CABLE	AW 22
MAW-2-HC w/18/2 SJO CABLE	AW 22
MAW-2-HC-BC	AW 23
MAW-2-HC-BC-R/A	AW 23
Interface Details	AW 24
Contact Configurations	AW 25

PRODUCT NEWS

ALL-WET SERIES CONNECTOR ENHANCEMENTS

INTRODUCTION

As part of our continuous improvement process the SEACON Group consistently reviews its product ranges through both customer feedback and internal improvements. It is via these processes that SEACON identified a design enhancement to the ALL-WET connector ranges.

DESIGN FEATURES

The design change is associated with the Male Pin connectors only and has been introduced to improve and extend the life of the connectors by decreasing the stresses that are applied to the sealing interface between the male contact pin and the sealing rubber around the pin during the connectors mate and de-mate cycles.

The newly designed male contact has a "Lead in" as part of the contact pin itself which replaces the current rubber lead in. The introduction of the new pin removes any potential wear to the sealing interface between the male contact pin and the sealing rubber around the pin which may occur with many repeated make and breaks of the connector pairs. The new pin will maintain the full connector sealing properties and will provide a greater life expectancy of the connectors.

The incorporation of this design change to the Male Pin connectors will not affect the existing Female Socket connectors currently being used by SEACON's customers and therefore full intermateability will be maintained. In addition, SEACON would also like to confirm that pricing will also not be affected.

Please note that the new Male Pin is not yet available across the entire ALL-WET range. Please contact SEACON for details.

TESTING

This new pin design concept has been fully tested and has been utilized in both the U-MATE and SEA-MATE connector ranges for a number of years.

INTRODUCTION

SEACON's ALL-WET connector series was developed to provide inexpensive yet reliable rubber molded connectors that allow the user to make and break connections both on the surface and underwater.

Manufactured using only high quality materials, the ALL-WET bulkhead connector's metal shell is produced using CA630 per QQ-C 465 as standard, although other materials are available upon request. Contacts are gold plated to ASTM B488 providing superior corrosion resistance.

AVAILABILITY

The ALL-WET range offers four different style types; round (AW), split (AW), flat (FAW) and miniature hermaphroditic (MAW) with a number of configurations ranging from 2 to 54 contacts rated upto 50 amps maximum current (dependent on cable) and a mated pressure rating of upto 20,000 psi.

APPLICATIONS

The ALL-WET series is suitable for a variety of applications including underwater television and lights, diver communications, ROV systems, recreational submersibles, towed-array cable systems, current meters, animal migration and research and food processing equipment.

PART NUMBER SYSTEM - EXAMPLE

ALL-WET ROUND SERIES BULKHEAD CONNECTORS

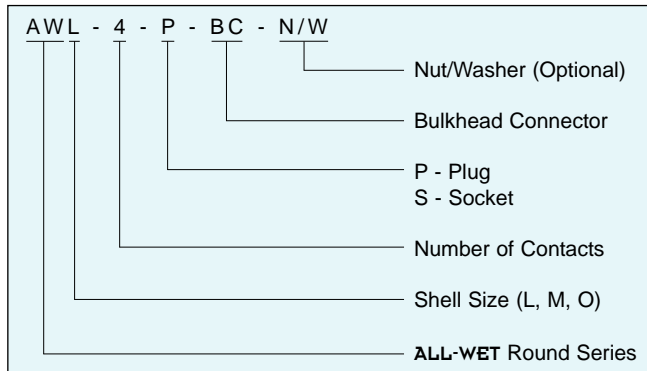

SPECIAL ASSEMBLIES

SEACON maintains all facilities necessary to furnish complete underwater and environmental electrical connector/cable systems, including Research and Development, Engineering, Manufacturing, Quality Control and Pressure Testing.

As well as supplying our standard 'off-the-shelf' items, we have the capability to design and manufacture **SPECIAL CUSTOMIZED CONNECTORS AND CABLE ASSEMBLIES** to suit your individual needs.

SEACON also prides itself with the ability to perform stringent quality conformance testing procedures which are in accordance with the MIL-SPEC programs.

NOTE:

ALL-WET connectors are intended to mate with ALL-WET connectors only. Although the ALL-WET and WET-CON connectors look similar, the numbering pattern and color codes are not the same.

We recommend, as general practice, to verify color code and pin location before installation.

ALL-WET ROUND SERIES IN-LINE CONNECTORS

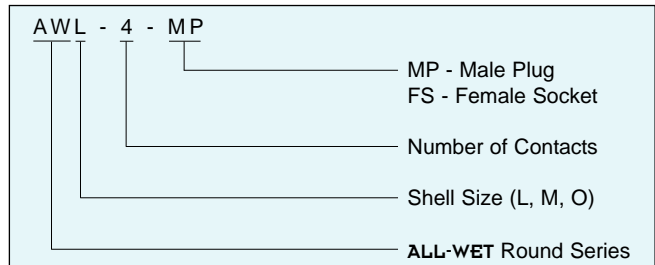

ALL-WET ROUND SERIES IN-LINE LOCKING SLEEVES

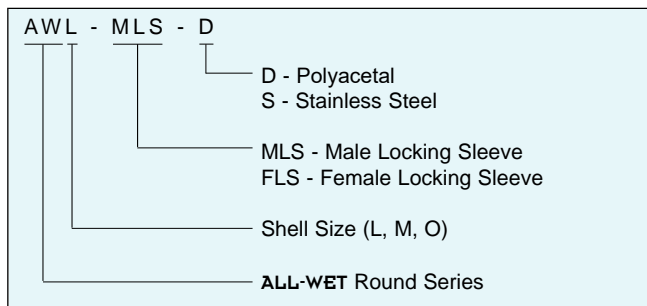

ALL-WET ROUND SERIES BULKHEAD LOCKING SLEEVES

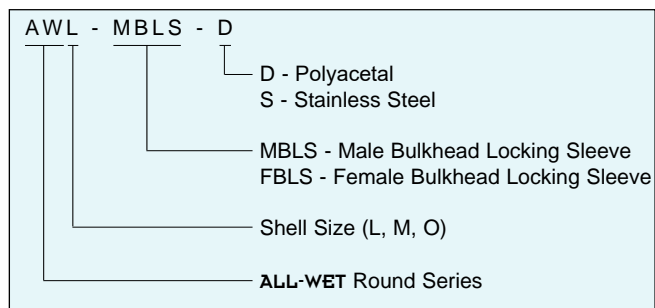

ALL-WET ROUND SERIES DUMMY CONNECTORS

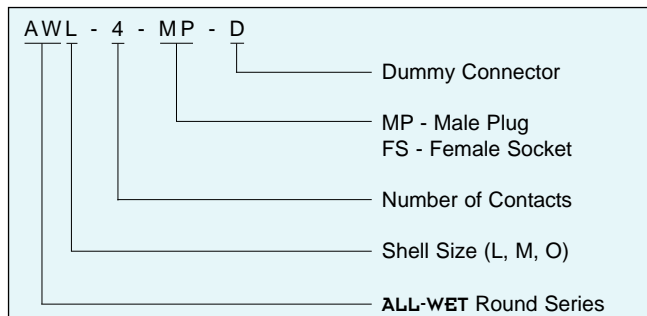

GENERAL INFORMATION

COMPONENT	MATERIAL
BULKHEAD BODY: STANDARD: OPTIONAL:	CA630 per QQ-C-465 Many materials including 316 Stainless Steel and Glass Reinforced Epoxy (GRE). Other materials available on request
CONNECTOR BODY	Neoprene per B/A X5727
CONTACTS	Copper Alloy Gold Plated per ASTM B488
GUIDE PINS	304 Stainless Steel
O-RINGS	Nitrile (formerly known as Buna N)
IN-LINE CABLE	#18 AWG SO as standard
BULKHEAD PIGTAILS	TFE insulated wire type E hook-up wire

CATEGORY	VALUE
OPEN FACE PRESSURE	Up to 1,000 psi (contact SEACON for higher ratings)
MATED PRESSURE BULKHEADS	Up to 10,000 psi
MATED PRESSURE IN-LINES	20,000 psi
VOLTAGE	600 VDC based on standard cable (contact SEACON for higher ratings)
CURRENT	Up to 50 amps per contact available. Please contact SEACON
CONTACT RESISTANCE	<0.01 ohms
INSULATION RESISTANCE	>500 megohms after wet mating

NOTES:

- Locking sleeves are at additional charge and must be specified. We recommend that bulkhead locking sleeves are specified to be installed at the factory.
- Bulkhead nut/washer is not standard and must be ordered separately. Available in Stainless Steel although other materials are available on request.
- In-line cable and hook up wire is 18 inch as standard, longer lengths to be specified when ordering.
- Please contact SEACON for your non standard cable requirements. Some cables may require terminating to a bulkhead connector and overmolding.

AMPACITY CHART FOR STANDARD PARTS (18 AWG SO CABLE)

PART DESCRIPTION NUMBER OF CONTACTS	AMPACITY
AWL - 2	7 amps
AWL - 3	7 amps
AWL - 4	5.6 amps
AWL - 5	5.6 amps

PART DESCRIPTION NUMBER OF CONTACTS	AMPACITY
AWM - 6	5.6 amps
AWM - 8	4.9 amps
AWO - 12	3.5 amps

STANDARD IN-LINE WIRING COLOR CODE (SO CABLE)

CONTACT #	COLOR
1	WHITE
2	BLACK
3	GREEN
4	RED
5	ORANGE
6	BLUE

CONTACT #	COLOR
7	WHITE/BLACK
8	RED/BLACK
9	GREEN/BLACK
10	ORANGE/BLACK
11	BLUE/BLACK
12	BLACK/WHITE

CAUTION:

- ALL-WET connectors are intended to mate with ALL-WET connectors only. Although the ALL-WET and WET-CON connectors look similar, the numbering pattern and color codes are not the same. We recommend as general practice, to verify color code and pin location before installation.

ALL-WET SERIES AW-P-BC

ALL-WET Round Bulkhead Connector
Mates with AW-FS
Dummy Connector: AW-FSD

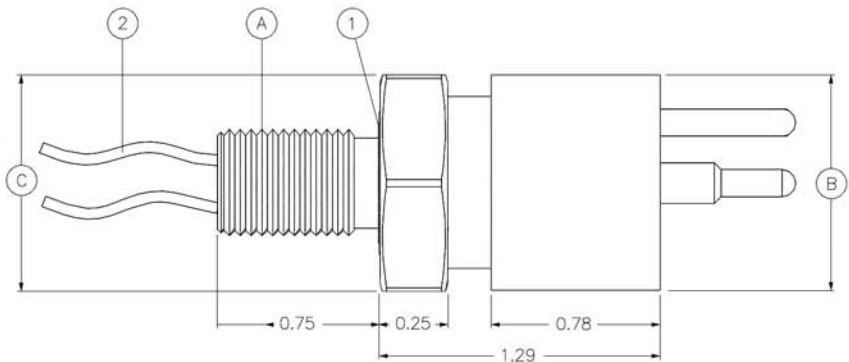
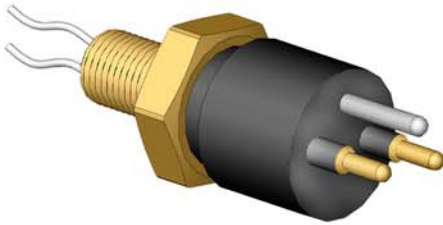

ALL-WET SERIES AW-S-BC

ALL-WET Round Bulkhead Connector
Mates with AW-MP
Dummy Connector: AW-MPD

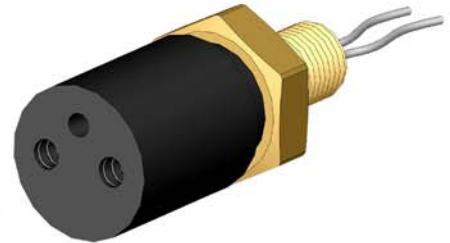
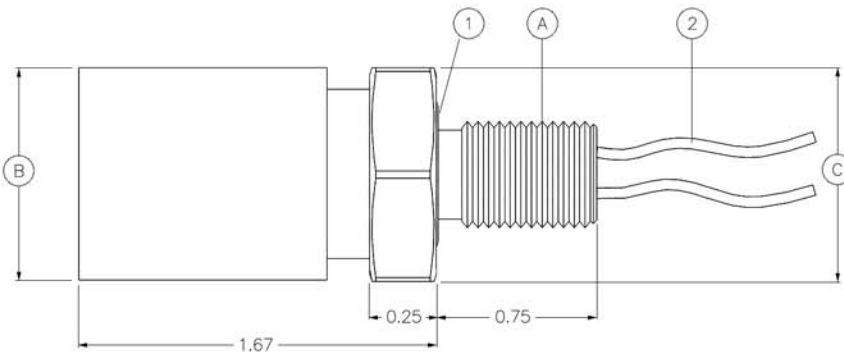

CONNECTOR	A - THREAD	B - Ø (INCHES)	C - HEX FLATS (INCHES)	1 - O-RING	2 - HOOK-UP WIRE	BULKHEAD MOUNTING TORQUE (INCH POUNDS)
AWL-P/S-BC	1/2-20 UNF-2A	1.00	1.00	2-114	18 AWG	50
AWM-P/S-BC	3/4-16 UNF-2A	1.25	1.25	2-118	18 AWG	85
AWO-P/S-BC	1-14 UNS-2A	1.60	1.62	2-122	18 AWG	125

GRE SPECIAL ORDER SIZES

CONNECTOR	A - THREAD	B - Ø (INCHES)	C - HEX FLATS (INCHES)	1 - O-RING	2 - HOOK-UP WIRE	BULKHEAD MOUNTING TORQUE (INCH POUNDS)
AWL-P/S-BC	1/2-20 UNF	1.00	1.00	2-114	18 AWG	15
AWL-P/S-BC	3/4-16 UNS*	1.00	1.25	2-118	18 AWG	50
AWM-P/S-BC	3/4-16 UNF	1.25	1.25	2-118	18 AWG	50
AWM-P/S-BC	1-14 UNS*	1.25	1.50	2-122	18 AWG	85
AWO-P/S-BC	1-14 UNS	1.60	1.62	2-122	18 AWG	85

NOTES:

- * Optional, more robust design.
- Bulkhead Locking Sleeve: Optional; Factory installation only for AWL/M/O-BC (see page 10).
- Nut and washer: Optional.
- Dummy Connector: Optional.
- Dummy Shorting Plug Connector: Optional.
- Connectors must be lubricated prior to mating.
- Torque values referenced in this literature assume installation into dry metal threads. For other applications, please contact SEAICON for recommendations.
- Connectors are designed for installation on one atmosphere vessels. Contact SEAICON for recommendations if using compensated vessels.

ALL-WET SERIES AW-MP

ALL-WET Round In-Line Connector
Mates with AW-FS and AW-S-BC
Dummy Connector: AW-FSD

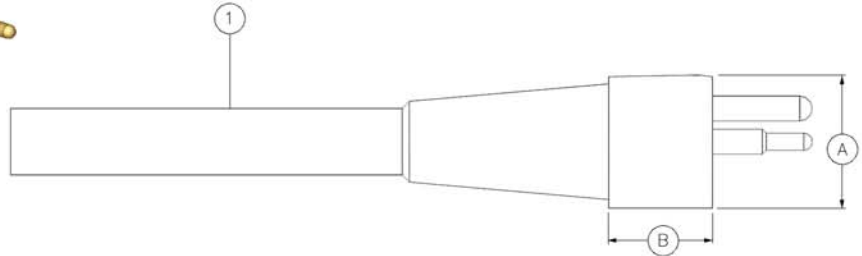

ALL-WET SERIES AW-FS

ALL-WET Round In-Line Connector
Mates with AW-MP and AW-P-BC
Dummy Connector: AW-MPD

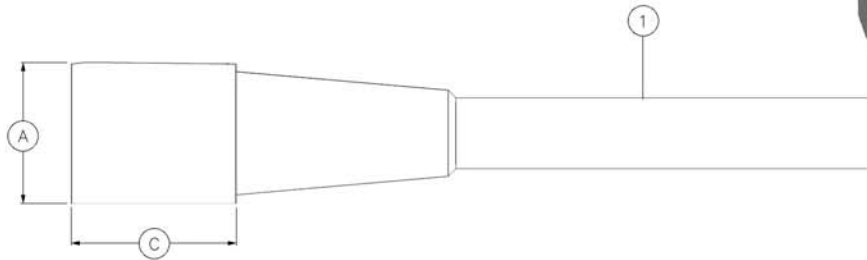

CONNECTOR	A - Ø (INCHES)	B - LENGTH (INCHES)	C - LENGTH (INCHES)	1 - STANDARD CABLE	MAXIMUM CABLE O.D.
AWL-MP/FS	1.00	0.78	1.16	18 AWG SO	1/2 (0.500)
AWM-MP/FS	1.25	0.78	1.16	18 AWG SO	7/8 (0.875)
AWO-MP/FS	1.60	0.78	1.16	18 AWG SO	1 1/4 (1.250)

NOTES:

- Locking Sleeve: Optional (see page 10).
- Dummy Connector: Optional.
- Dummy Shorting Plug Connector: Optional.
- Connectors must be lubricated prior to mating.

ALL-WET SERIES AW-P-BC with Ground (w/G)

ALL-WET Round Bulkhead Connector
Mates with AW-FS
Dummy Connector: AW-FSD

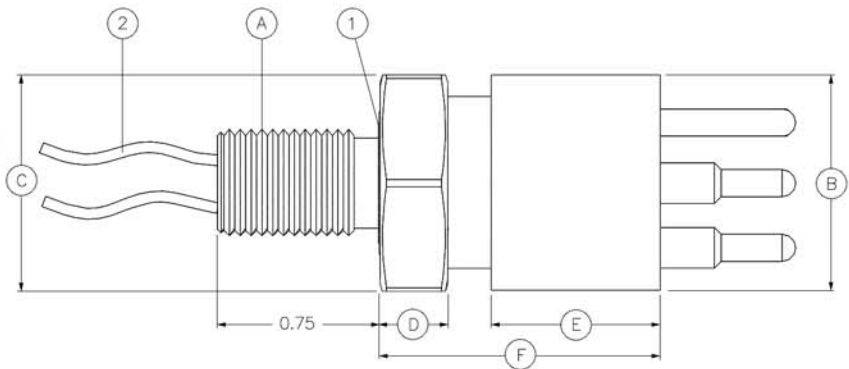
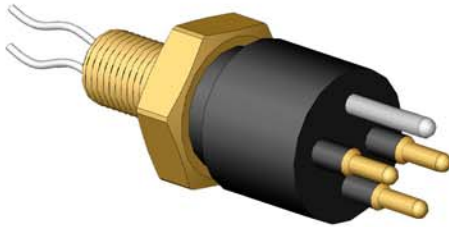

ALL-WET SERIES AW-S-BC with Ground (w/G)

ALL-WET Round Bulkhead Connector
Mates with AW-MP
Dummy Connector: AW-MPD

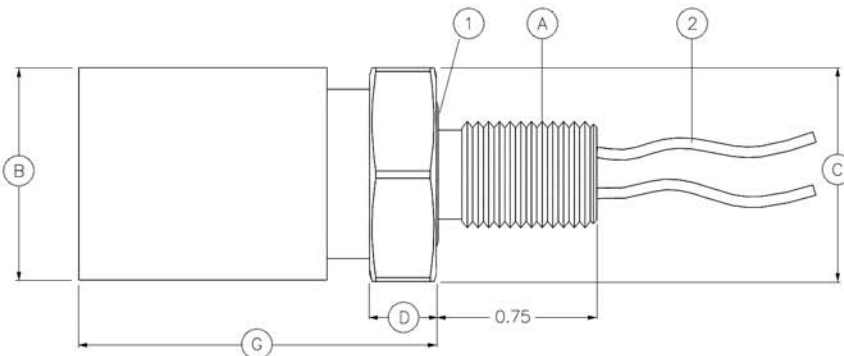

CONNECTOR	A - THREAD	B - Ø (INCHES)	C - HEX FLATS (INCHES)	D - LENGTH (INCHES)	E - LENGTH (INCHES)	F - LENGTH (INCHES)	G - LENGTH (INCHES)	1 - O-RING	2 - HOOK-UP WIRE	BULKHEAD MOUNTING TORQUE (INCH POUNDS)
AWL-P/S-BC-w/G	1/2-20 UNF-2A	1.00	1.00	0.25	0.78	1.29	1.67	2-114	18 AWG	50
AWM-P/S-BC-w/G	3/4-16 UNF-2A	1.25	1.25	0.25	0.78	1.29	1.67	2-118	18 AWG	85
AWO-P/S-BC-w/G	1-14 UNS-2A	1.60	1.62	0.50	1.15	2.31	2.69	2-122	8 AWG	125

GRE SPECIAL ORDER SIZES

CONNECTOR	A - THREAD	B - Ø (INCHES)	C - HEX FLATS (INCHES)	1 - O-RING	2 - HOOK-UP WIRE	BULKHEAD MOUNTING TORQUE (INCH POUNDS)
AWL-P/S-BC-w/G	1/2-20 UNF	1.00	1.00	2-114	18 AWG	15
AWL-P/S-BC-w/G	3/4-16 UNS*	1.00	1.25	2-118	18 AWG	50
AWM-P/S-BC-w/G	3/4-16 UNF	1.25	1.25	2-118	18 AWG	50
AWM-P/S-BC-w/G	1-14 UNS*	1.25	1.50	2-122	18 AWG	85
AWO-P/S-BC-w/G	1-14 UNS	1.60	1.62	2-122	8 AWG	85

NOTES:

- This series offers a ground pin that will make contact prior to the line pins and break contact last upon demating.
- * Optional, more robust design.
- Optional thread sizes: AWL-7/16-20 UNF-2A. AWM-5/8-18 UNF-2A.
- Bulkhead Locking Sleeve: Optional; Factory installation only for AWL/M/O-BC (see page 10).
- Nut and washer: Optional.
- Dummy Connector: Optional.
- Dummy Shorting Plug Connector: Optional.
- Connectors must be lubricated prior to mating.
- Torque values referenced in this literature assume installation into dry metal threads. For other applications, please contact SEACON for recommendations.
- Connectors are designed for installation on one atmosphere vessels. Contact SEACON for recommendations if using compensated vessels.

ALL-WET SERIES AW-MP with Ground (w/G)

ALL-WET Round with Ground In-Line Connector
Mates with AW-FS and AW-S-BC
Dummy Connector: AW-FSD

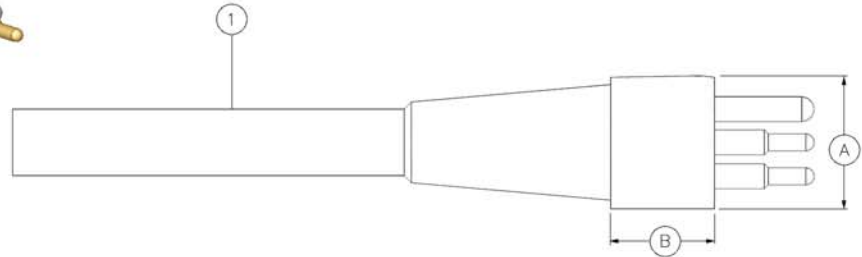

ALL-WET SERIES AW-FS with Ground (w/G)

ALL-WET Round with Ground In-Line Connector
Mates with AW-MP and AW-P-BC
Dummy Connector: AW-MPD

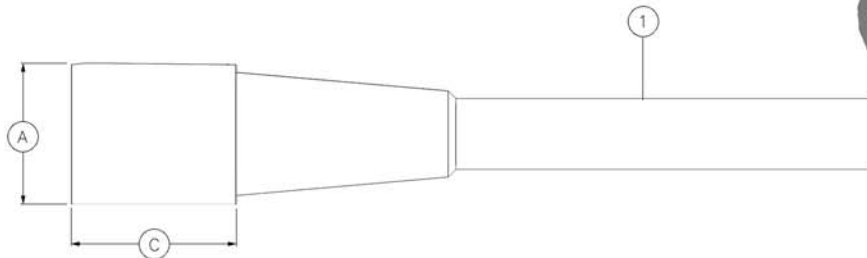

CONNECTOR	A - Ø (INCHES)	B - LENGTH (INCHES)	C - LENGTH (INCHES)	1 - STANDARD CABLE	MAXIMUM CABLE O.D.
AWL-MP/FS-w/G	1.00	0.78	1.16	18 AWG SO	1/2 (0.500)
AWM-MP/FS-w/G	1.25	0.78	1.16	18 AWG SO	7/8 (0.875)
AWO-MP/FS-w/G	1.85	1.39	1.23	8 AWG SO	1 1/4 (1.250)

STANDARD IN-LINE w/GROUND COLOR CODE

AWL-2 w/G-MP/FS

CONTACT #	COLOR
1	WHITE
2	BLACK
G	GREEN

AWL-3 w/G-MP/FS AWM-3 w/G-MP/FS

CONTACT #	COLOR
1	WHITE
2	BLACK
3	RED
G	GREEN

AWM-5 w/G-MP/FS

CONTACT #	COLOR
1	WHITE
2	BLACK
3	RED
4	ORANGE
5	BLUE
G	GREEN

AWO-15 w/G-MP/FS

CONTACT #	COLOR
1	WHITE
2	BLACK
3	RED
4	ORANGE
5	BLUE
6	WHITE/BLACK
7	RED/BLACK
8	GREEN/BLACK
9	ORANGE/BLACK
10	BLUE/BLACK
11	BLACK/WHITE
12	GREEN/WHITE
13	RED/WHITE
14	BLUE/WHITE
15	BLACK/RED
G	GREEN

NOTES:

- This series offers a ground pin that will make contact prior to the line pins and break contact last upon demating.
- Locking Sleeve: Optional (see page 10).
- Dummy Connector: Optional.
- Dummy Shorting Plug Connector: Optional.
- Connectors must be lubricated prior to mating.
- For Bulkhead Connectors, please contact SEACON for availability.
- AWO-15 w/G has one pin that makes contact last.

**ALL-WET SERIES
FLS**

ALL-WET Female Locking Sleeve

**ALL-WET SERIES
MLS**

ALL-WET Male Locking Sleeve

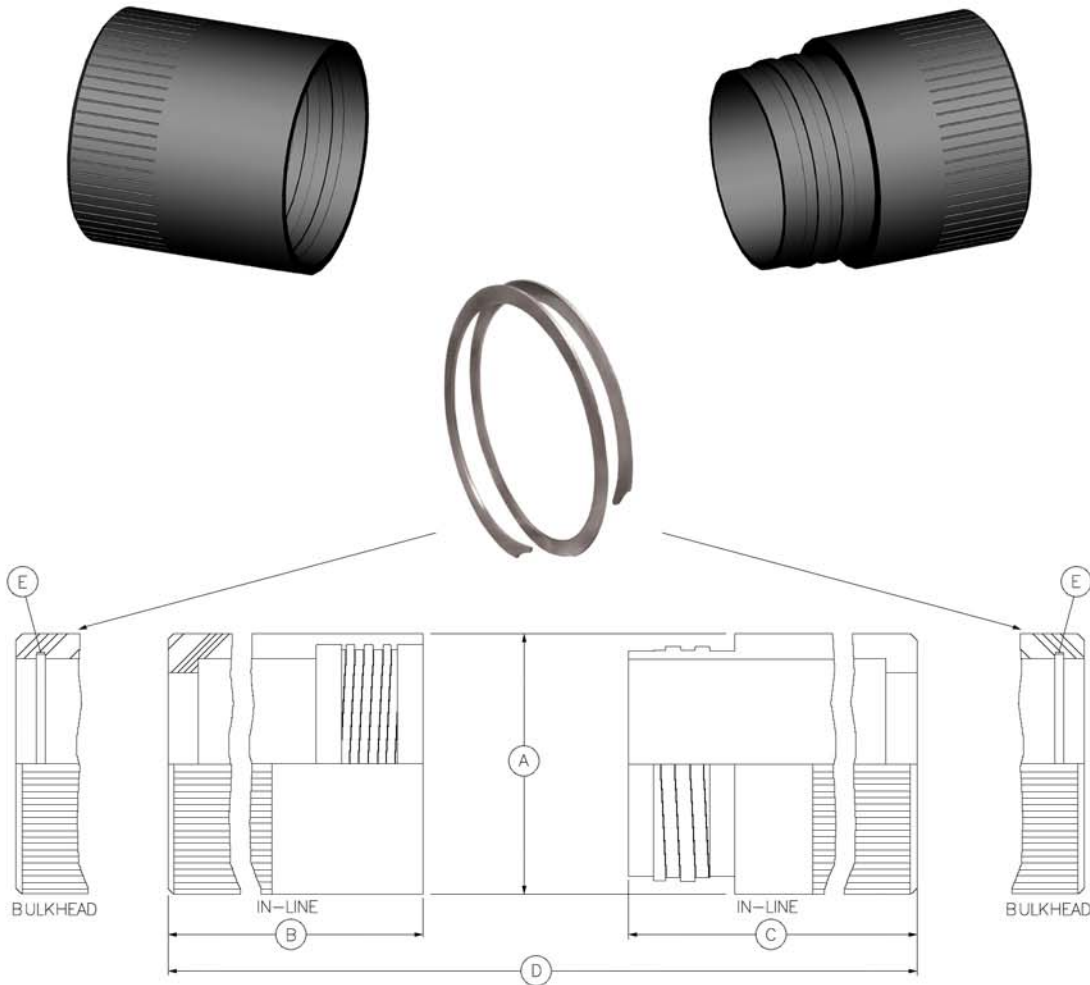

ALL-WET LOCKING SLEEVES		A - Ø (INCHES)	B - LENGTH (INCHES)	C - LENGTH (INCHES)	D - LENGTH (INCHES)	E - SPIROLOX
IN-LINE	BULKHEAD					
AWL-FLS	AWL-FBLS	1.25	1.23	-	2.10	RR-100
AWL-MLS	AWL-MBLS	1.25	-	1.38	2.10	RR-100
AWM-FLS	AWM-FBLS	1.50	1.23	-	2.10	RR-125
AWM-MLS	AWM-MBLS	1.50	-	1.38	2.10	RR-125
AWO-FLS	AWO-FBLS	1.85	1.23	-	2.10	RR-162
AWO-MLS	AWO-MBLS	1.85	-	1.38	2.10	RR-162
-	AWQ-FBLS	2.50	1.44	-	2.94	-
AWQ-MLS	-	2.50	-	2.00	2.94	-

NOTES:

- D - Polyacetal.
- S - Stainless Steel.
- Locking Sleeves will fit standard ALL-WET Connectors and ALL-WET Split Connectors.
- Specify Bulkhead or In-Line type locking sleeve.
- Bulkhead Locking Sleeve: Optional.
- If locking sleeves are required for AWL/M/O bulkhead connectors, they must be specified at time of connector order as they are factory installations only.

**ALL-WET SERIES
AW-P/S-BC
THROUGH BORE OPTION**
ALL-WET Round Bulkhead Connector

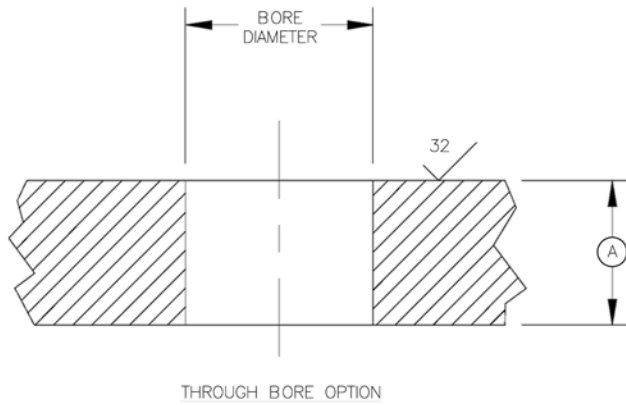

**ALL-WET SERIES
AW-P/S-BC
THREADED MOUNTING OPTION**
ALL-WET Round Bulkhead Connector

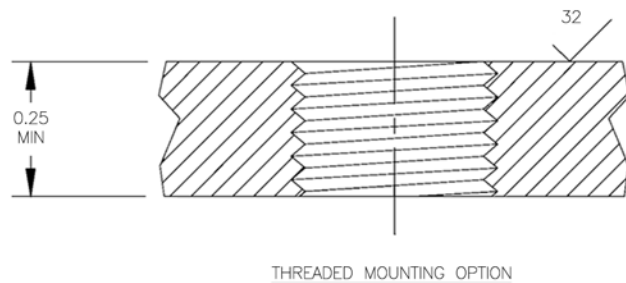

CONNECTOR	THREAD	BORE Ø (INCHES)	MOUNTING TORQUE (INCH POUNDS)	SPOT FACE Ø (INCHES)	A - MAX (INCHES)
AWL-BC	1/2-20 UNF-2A	0.500 +0.015 -0.000	50	1.19	0.44
AWM-BC	3/4-16 UNF-2A	0.750 +0.015 -0.000	85	1.50	0.44
AWO-BC	1-14 UNS-2A	1.000 +0.015 -0.000	125	1.88	0.44

SIZE	ALL-WET ROUND SERIES CONTACT CONFIGURATIONS (FEMALE FACE VIEW ONLY* - NOT TO SCALE)					
L	<p>2</p>	<p>3</p>	<p>4***</p>	<p>5</p>	<p>2 w/GRD**</p>	<p>3 w/G**</p>
M	<p>6</p>	<p>8</p>	<p>8x</p>	<p>3 w/G**</p>	<p>5 w/G**</p>	
O	<p>12S</p>	<p>3 w/G**</p>	<p>15 w/G**</p>			

NOTES:

- * For male face view contact configurations available please contact SEACON.
- ** ALL-WET series w/Ground.
- *** AWL-4-S mates with AWL-2/4-MP Split connectors.

S E A C O N



ALL-WET SPLIT SERIES

UNDERWATER ELECTRICAL WET-MATE CONNECTORS

GENERAL INFORMATION

COMPONENT	MATERIAL
BULKHEAD BODY: STANDARD: OPTIONAL:	CA630 per QQ-C-465* Many materials including 316 Stainless Steel, 6A14V Titanium, Glass Reinforced Epoxy (GRE)
CONNECTOR BODY: STANDARD: OPTIONAL:	Neoprene per B/A X5727 Hypalon per B/A X6830
CONTACTS	Copper Alloy Gold Plated per ASTM B488
GUIDE PINS	304 Stainless Steel
O-RINGS	Nitrile (formerly known as Buna N)

CATEGORY	VALUE
OPEN FACE PRESSURE	Up to 1,000 psi
MATED PRESSURE	Up to 10,000 psi
VOLTAGE	Will vary by pattern, determined by the cable
CURRENT	Up to 13 amps per contact**
CONTACT RESISTANCE	<0.01 ohms
INSULATION RESISTANCE	>500 megohms after wet mating
MATING CYCLES	>500 wet matings***

NOTES:

- * Except AWM-2/12S-BC (Standard = 316 Stainless Steel).
- ** Maximum current carrying capacity for contacts may be affected by cable selection.
- *** Provided proper handling procedures are adhered to.
- Locking sleeves are not standard and must be ordered separately. Available in Polyacetal or Stainless Steel.
- Bulkhead nut/washer is not standard and must be ordered separately. Available in Stainless Steel.

AMPACITY CHART FOR STANDARD PARTS

Please see page 15 of this ALL-WET Split section.

STANDARD IN-LINE WIRING COLOR CODE (SO CABLE)

CONTACT #	COLOR
1	WHITE
2	BLACK
3	GREEN
4	RED
5	ORANGE
6	BLUE

CONTACT #	COLOR
7	WHITE/BLACK
8	RED/BLACK
9	GREEN/BLACK
10	ORANGE/BLACK
11	BLUE/BLACK
12	BLACK/WHITE

PART NUMBER SYSTEM - EXAMPLE

ALL-WET SPLIT SERIES BULKHEAD CONNECTORS

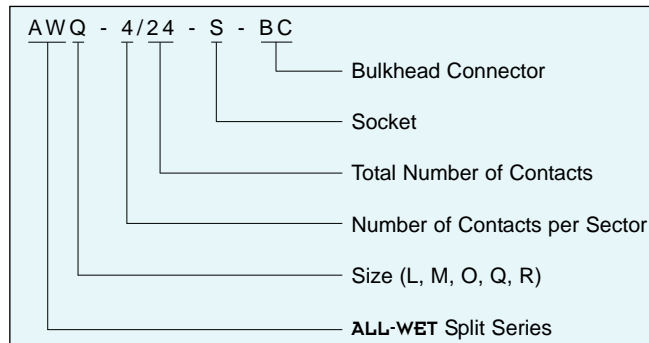

ALL-WET SPLIT SERIES IN-LINE CONNECTORS

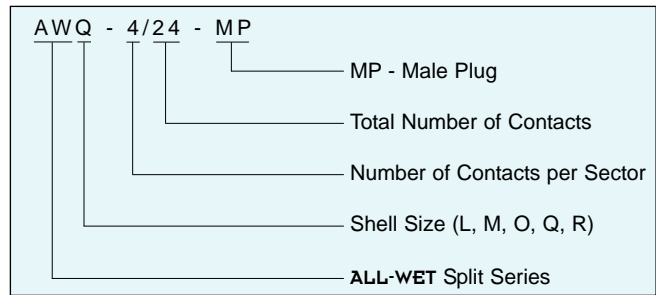

ALL-WET SPLIT SERIES LOCKING SLEEVES

Locking sleeves are available for ALL-WET Split Series connectors as an option, see page 10.

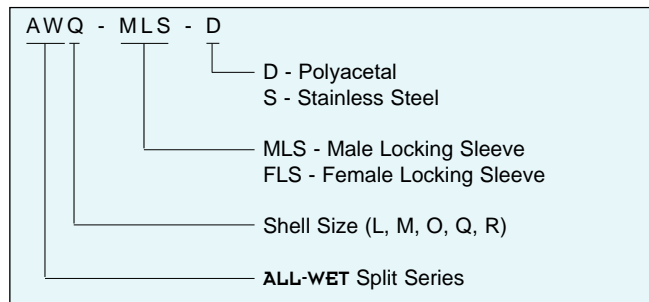

ALL-WET SPLIT SERIES DUMMY CONNECTORS

Dummy male plug connectors are available for all bulkhead connectors in the ALL-WET Split Series. To order, add the suffix-D after the part number.

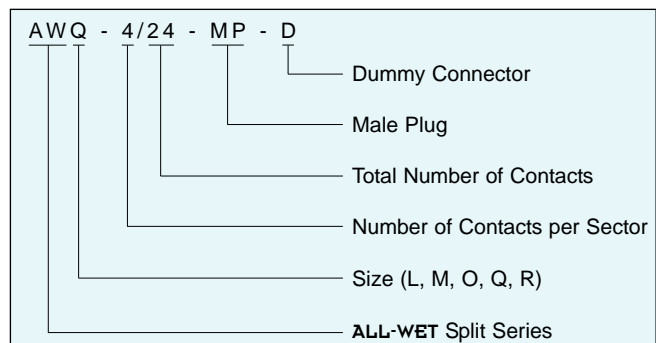

**ALL-WET SERIES
AW-MP SPLIT**

ALL-WET Split In-Line Pie Connector



**ALL-WET SERIES
AW-S-BC**

ALL-WET Split Bulkhead Connector

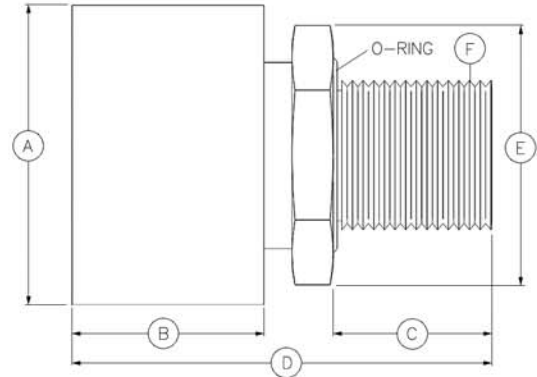
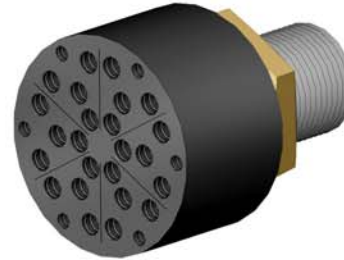

CONNECTOR	A - Ø (INCHES)	B - LENGTH (INCHES)	C - LENGTH (INCHES)	D - LENGTH (INCHES)	E - LENGTH (INCHES)	F - THREAD	O - RING	BC 18" TFE INSULATED WIRE TYPE E HOOK-UP WIRE	MP w/18" CABLE	VDC	AMP PER CONTACT	CABLE AMPACITY	BULKHEAD MOUNTING TORQUE (INCH POUNDS)
AWL-2/4*	1.00	1.16	0.75	2.42	1.00	1/2-20 UNF-2A	2-114	18 AWG	18/2 SJO	300	19	7.0	50
AWM-2/12	1.25	1.16	0.75	2.42	1.25	1/2-20 UNF-2A	2-114	20 AWG	18/2 SJO	300	19	7.0	50
AWO-2/12	For dimension details and ratings please contact SEACON.												
AWQ-2/8	2.00	1.28	1.00	2.80	1.50	1-14 UNS-2A	2-123	18 AWG	18/2 SO	600	19	7.0	125
AWQ-6/12	2.00	1.28	1.00	2.80	1.50	1-14 UNS-2A	2-123	18 AWG	18/6 SO	600	19	5.6	125
AWQ-2/16	2.00	1.28	1.00	2.80	1.50	1-14 UNS-2A	2-123	18 AWG	18/2 SO	600	19	7.0	125
AWQ-2/24	2.00	1.28	1.00	2.80	1.50	1-14 UNS-2A	2-123	18 AWG	18/2 SJO	300	10	7.0	125
AWQ-4/24	2.00	1.28	1.00	2.80	1.50	1-14 UNS-2A	2-123	18 AWG	18/4 SO	600	19	5.6	125
AWQ-4/28	2.00	1.28	1.00	2.80	1.50	1-14 UNS-2A	2-123	18 AWG	18/4 SO	600	19	5.6	125
AWQ-8/24	2.00	1.28	1.00	2.80	1.50	1-14 UNS-2A	2-123	18 AWG	18/8 SO	600	19	4.9	125
AWQ-8/32	2.00	1.28	1.00	2.80	1.50	1-14 UNS-2A	2-123	18 AWG	18/8 SO	600	10	4.9	125
AWQ-6/36	2.00	1.28	1.00	2.80	1.50	1-14 UNS-2A	2-123	20 AWG	18/6 SO	600	10	5.6	125
AWQ-12/36	2.00	1.28	1.00	2.80	1.50	1-14 UNS-2A	2-123	20 AWG	18/12 SO	600	10	3.5	125
AWQ-7/42	2.00	1.28	1.00	2.80	1.50	1-14 UNS-2A	2-123	20 AWG	18/7 SO	600	10	4.9	125

GRE SPECIAL ORDER SIZES

CONNECTOR	THREAD	HEX FLATS (INCHES)	BULKHEAD MOUNTING TORQUE (INCH POUNDS)
AWL	1/2-20 UNF-2A	1.00	50
AWM	3/4-16 UNF-2A	1.25	85
AWO	1-14 UNS-2A	1.62	125
AWQ	1-14 UNS-2A	1.50	85

NOTES:

- Multiple connectors required to fill all sectors of bulkhead connector.
- Pressure Rating: 10,000 psi, mated/1,000 psi, open face.
- Dummy Connector: Optional. Please contact SEACON for availability.
- Dummy Shorting Plug Connector: Optional.
- Connectors must be lubricated prior to mating.
- Locking Sleeves: Optional (see page 10).
- Nut and washer: Optional.
- Torque values referenced in this literature assume installation into dry metal threads. For other applications, please contact SEACON for recommendations.
- Contact SEACON for custom cable molding needs.
- Bulkhead Locking Sleeve. Factory installation only for AWL/M-BC (see page 10).
- Connectors are designed for installation onto one atmosphere vessels. Contact SEACON for recommendations if using compensated vessels.
- * AWL-2/4 is available in 2 different MP's. 1) Has guide pin along with pins 1 & 4; 2) Has no guide pin and pins 3 & 4.

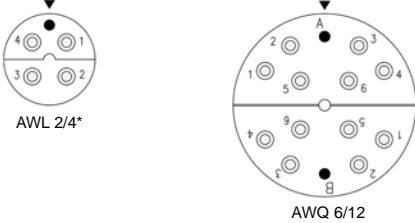
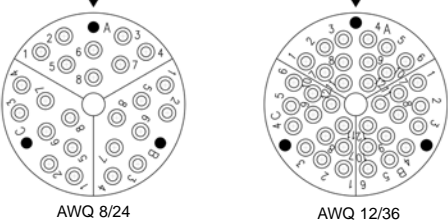
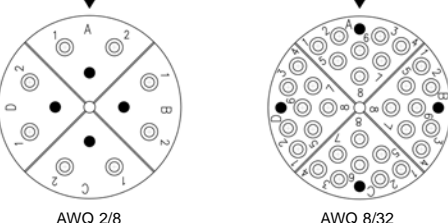
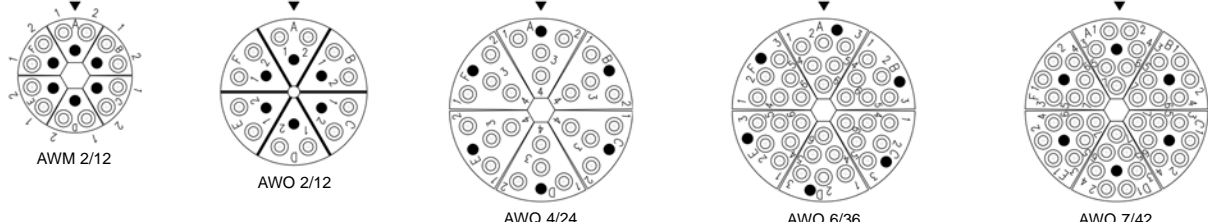
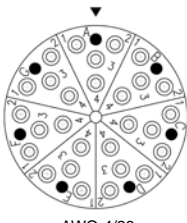
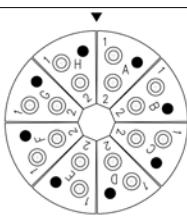
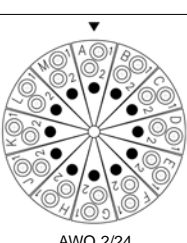
SIZE	ALL-WET SPLIT SERIES CONTACT CONFIGURATIONS (FEMALE FACE VIEW ONLY - NOT TO SCALE)
2	 <p>AWL 2/4*</p> <p>AWQ 6/12</p>
3	 <p>AWQ 8/24</p> <p>AWQ 12/36</p>
4	 <p>AWQ 2/8</p> <p>AWQ 8/32</p>
6	 <p>AWM 2/12</p> <p>AWO 2/12</p> <p>AWQ 4/24</p> <p>AWQ 6/36</p> <p>AWQ 7/42</p>
7	 <p>AWQ 4/28</p>
8	 <p>AWQ 2/16</p>
12	 <p>AWQ 2/24</p>

NOTES:

- All configurations shown are the face view of the Bulkhead Connector (BC). Standard bulkhead contacts are female.
- The mating male plugs (MP) are "split" into equally shaped sections.
- For customer configurations or special applications contact SEACON or sales representative.
- * AWL-2/4-MP mates with standard AWL-4S-BC.

S E A C O N



ALL-WET FLAT SERIES

UNDERWATER ELECTRICAL WET-MATE CONNECTORS

GENERAL INFORMATION

COMPONENT	MATERIAL
BULKHEAD BODY: STANDARD: OPTIONAL:	CA630 per QQ-C-465 Many materials including 316 Stainless Steel and 6A14V Titanium, Hard Anodized
CONNECTOR BODY: STANDARD: OPTIONAL:	Neoprene per B/A X5727 Hypalon per B/A X6830
CONTACTS	Copper Alloy Gold Plated per ASTM B488
O-RINGS	Nitrile (formerly known as Buna N)
IN-LINE CABLE: FAWL: FAWM 8: FAWM 10: MAW:	#18 AWG SO* #20 AWG SO* #22 AWG SO* IN2*
BULKHEAD NUT/WASHER	Brass
BULKHEAD PIGTAILS	TFE insulated wire Type E Hook-up wire FAWL #18 AWG* FAWM 8 #20 AWG* FAWM 10 #22 AWG* MAW IN2*

CATEGORY	VALUE
OPEN FACE PRESSURE #BULKHEADS	Up to 1,000 psi
MATED PRESSURE BULKHEADS	Up to 10,000 psi
MATED PRESSURE IN-LINES	Up to 10,000 psi
VOLTAGE FAW: MAW:	600 VDC except FAWM-10*** 300 VDC
CURRENT FAW: MAW:	Up to 10 amps per contact** Up to 3 amps per contact**
CONTACT RESISTANCE	<0.01 ohms
INSULATION RESISTANCE	>500 megohms after wet mating
MATING CYCLES	>500 wet matings****

NOTES:

- * 18 inch standard length.
- ** Maximum current carrying capacity for contacts may be affected by cable selection.
- *** Rated to 300 VDC.
- **** Provided proper handling procedures are adhered to.

AMPACITY CHART FOR STANDARD PARTS

PART DESCRIPTION NUMBER OF CONTACTS	AMPACITY
FAWL - 2	7 amps
FAWL - 3	7 amps
FAWL - 4	5.6 amps

· Higher ampacities are available.

PART DESCRIPTION NUMBER OF CONTACTS	AMPACITY
FAWL - 5	5.6 amps
FAWM - 8	4.9 amps
FAWM - 10	2.5 amps

STANDARD IN-LINE WIRING COLOR CODE

CONTACT #	COLOR
1	WHITE
2	BLACK
3	GREEN
4	RED
5	ORANGE

CONTACT #	COLOR
6	BLUE
7	WHITE/BLACK
8	RED/BLACK
9	GREEN/BLACK
10	ORANGE/BLACK

PART NUMBER SYSTEM - EXAMPLE

ALL-WET FLAT SERIES BULKHEAD CONNECTORS

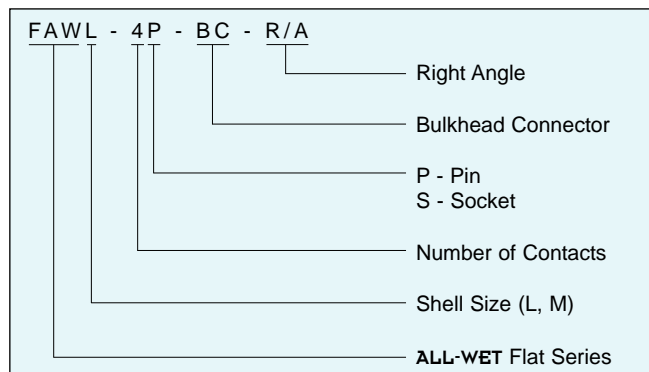

ALL-WET FLAT SERIES IN-LINE MP CONNECTORS

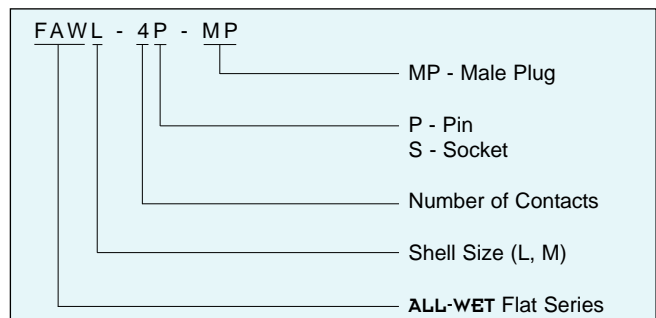

ALL-WET FLAT SERIES IN-LINE FS CONNECTORS

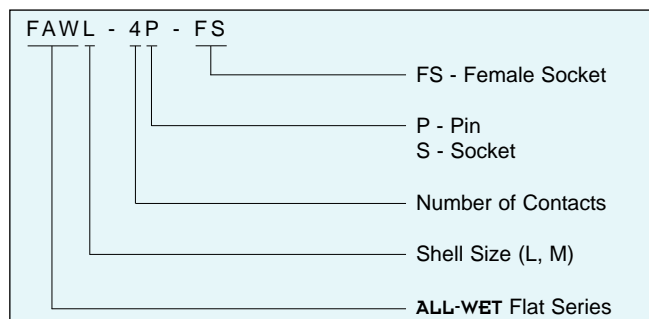

ALL-WET FLAT SERIES DUMMY CONNECTORS

Dummy connectors are available for all connectors in the ALL-WET Flat Series. To order, add the suffix-D after the part number.

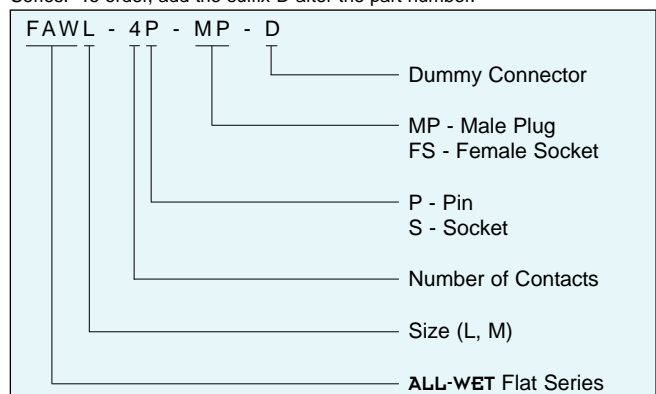

ALL-WET SERIES FAW-P-BC-R/A

ALL-WET Flat Bulkhead Connector
Mates with FAW-S-MP
Dummy Connector: FAW-S-MPD

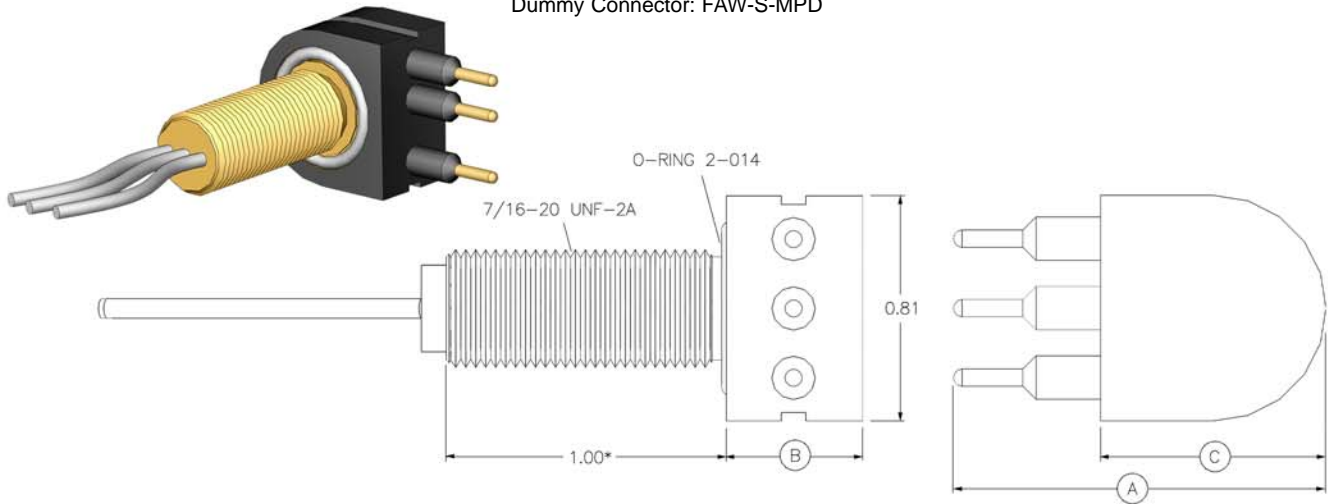

ALL-WET SERIES FAW-S-BC-R/A

ALL-WET Flat Bulkhead Connector
Mates with FAW-P-MP
Dummy Connector: FAW-P-MPD

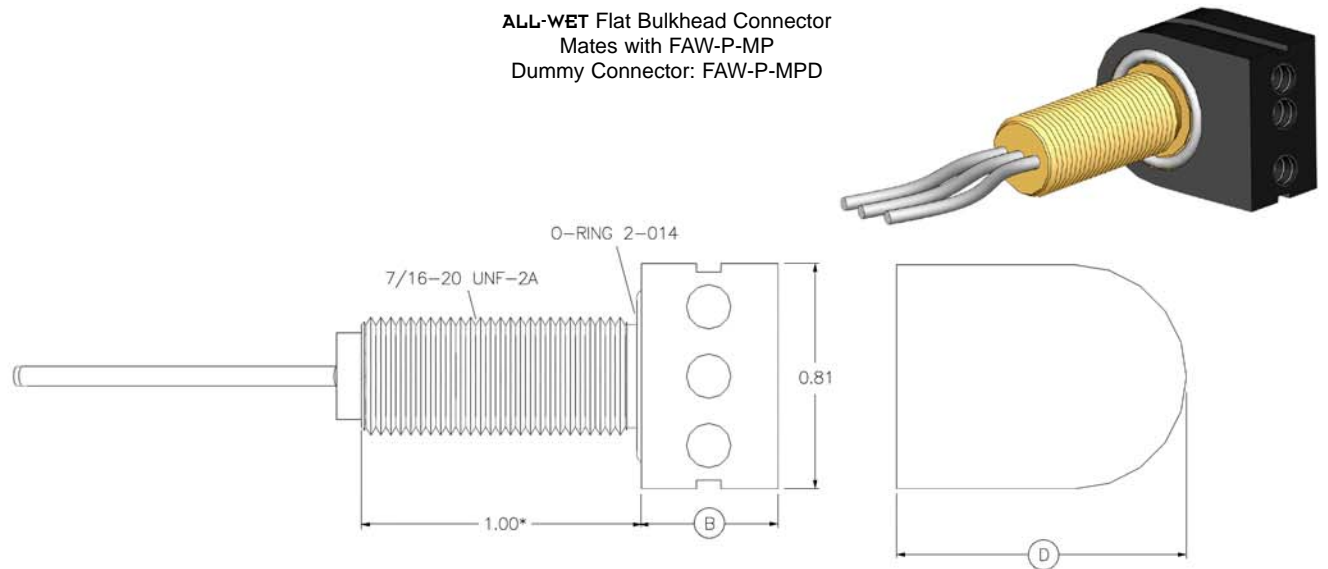

CONNECTOR	A - LENGTH (INCHES)	B - LENGTH (INCHES)	C - LENGTH (INCHES)	D - LENGTH (INCHES)
FAWL-P/S-BC-R/A	1.34	0.50	0.81	1.05
FAWM-P/S-BC-R/A	1.48	0.63	0.95	1.12

NOTES:

- Thread length is 1.00" standard. If shorter thread is required, specify as follows: FAW-P(or S)-BC-R/A (1/2" thread length).
- Available thread length: 1/2", 3/4" and 1".
- Bulkhead mounting torque: 40 inch pounds.
- Nuts and washer supplied.
- Connectors must be lubricated prior to mating.
- Connectors are designed for installation on one atmosphere vessels. Contact SEACON for recommendations if using compensated vessels.
- Dummy Connectors: Optional.
- Dummy Shorting Plug: Optional.

**ALL-WET SERIES
FAW-P-MP**

ALL-WET Flat In-Line Connector
Mates with FAW-S-FS and FAW-S-BC-R/A
Dummy Connector: FAW-S-FSD

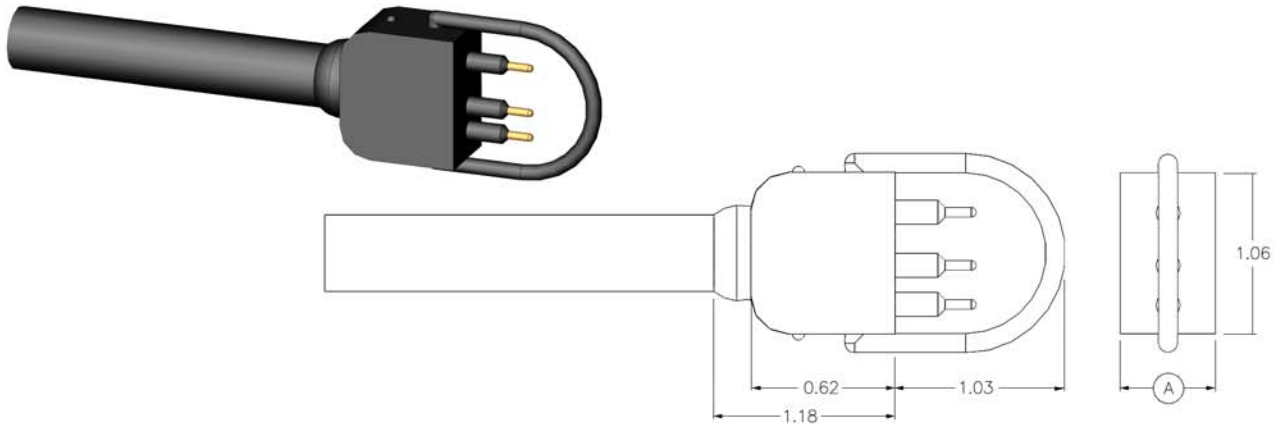

**ALL-WET SERIES
FAW-S-MP**

ALL-WET Flat In-Line Connector
Mates with FAW-P-FS and FAW-P-BC-R/A
Dummy Connector: FAW-P-FSD

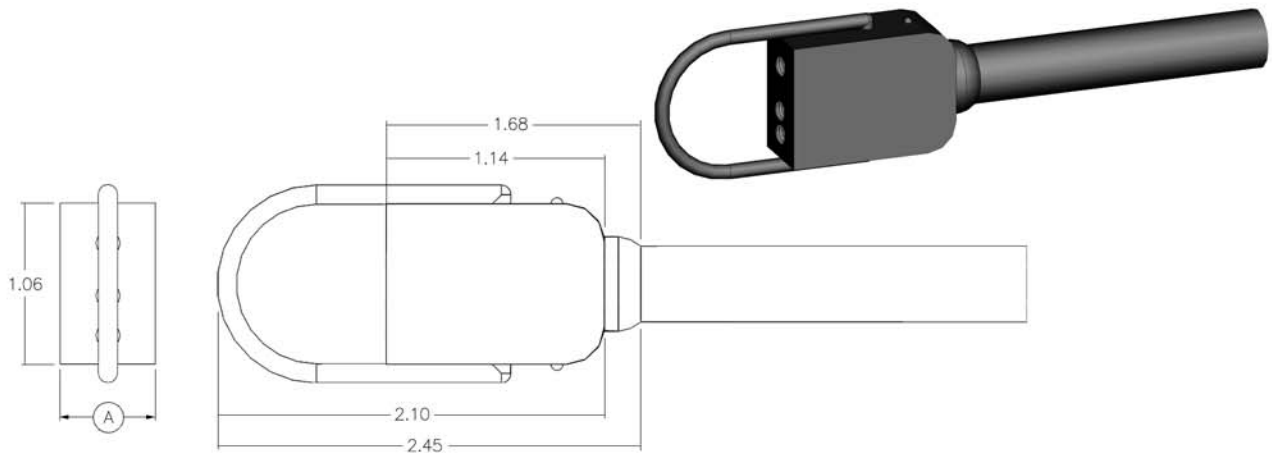

CONNECTOR	A - LENGTH (INCHES)
FAWL-P/S-MP	0.50
FAWM-P/S-MP	0.63

NOTES:

- Neoprene lanyard wraps around groove on in-line or bulkhead mate.
- Dummy connectors: Optional.
- Dummy Shorting Plug: Optional.
- Connectors must be lubricated prior to mating.

**ALL-WET SERIES
FAW-P-FS**

ALL-WET Flat In-Line Connector
Mates with FAWL-S-MP
Dummy Connector: FAW-S-MPD

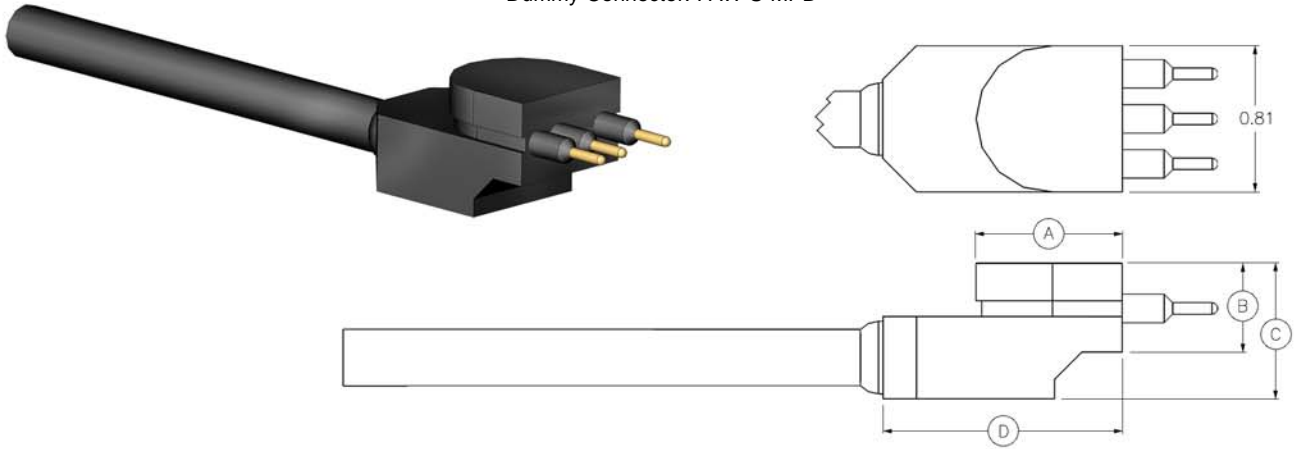

**ALL-WET SERIES
FAW-S-FS**

ALL-WET Flat In-Line Connector
Mates with FAWL-P-MP
Dummy Connector: FAW-P-MPD

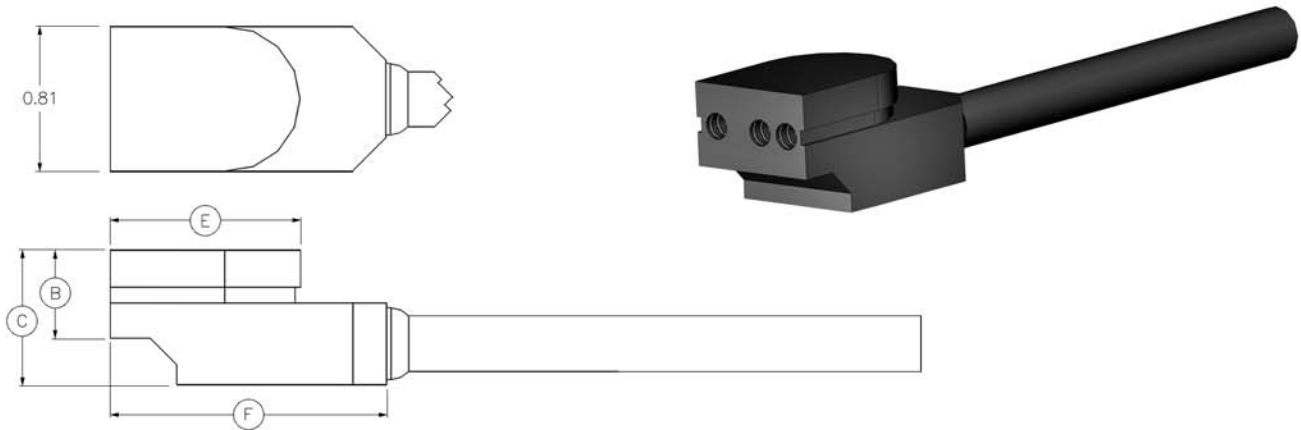

CONNECTOR	A - LENGTH (INCHES)	B - LENGTH (INCHES)	C - LENGTH (INCHES)	D - LENGTH (INCHES)	E - LENGTH (INCHES)	F - LENGTH (INCHES)
FAWL-P/S-FS	0.81	0.50	0.88	1.31	1.05	1.55
FAWM-P/S-FS	0.98	0.63	0.94	1.33	1.15	1.52

NOTES:

- Dummy Connector: Optional.
- Dummy Shorting Plug: Optional.
- Connectors must be lubricated prior to mating.

ALL-WET SERIES MAW-2-HC w/IN2 CABLE

ALL-WET Miniature Hermaphroditic In-Line Connector
Mates with itself and MAW-2-HC-BC-R/A

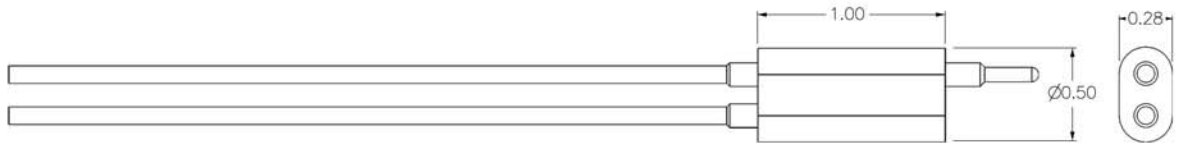

ALL-WET SERIES MAW-2-HC w/18/2 SJO CABLE

ALL-WET Miniature Hermaphroditic In-Line Connector
Mates with itself and MAW-2-HC-BC-R/A



NOTES:

- Current-carrying capacity: MAW-2-HC w/IN2 CABLE - 3 amps per contact.
MAW-2-HC w/18/2 SJO CABLE - 7 amps per contact.
- Operating pressure: 10,000 psi.
- Open face pressure: 1,000 psi.
- Working voltage: 300 VDC.
- Dummy Connector: Optional.
- Dummy Shorting Plug: Optional.
- Connectors must be lubricated prior to mating.

**ALL-WET SERIES
MAW-2-HC-BC**

ALL-WET Miniature Hermaphroditic Bulkhead Connector
Mates with MAW-2-HC

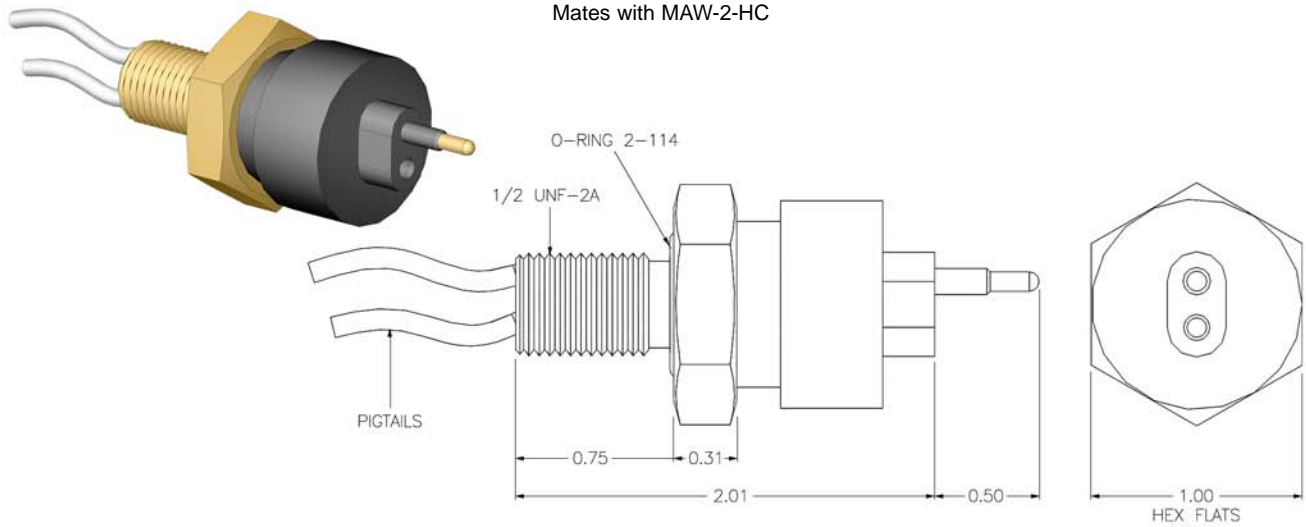

NOTES:

- Dummy connector: Optional.
- Dummy Shorting Plug: Optional.
- Pigtails: 18 AWG Type E, 18 inches long.
- Connectors must be lubricated prior to mating.
- Nut and washer: Optional.
- For GRE bulkhead mounting torques please contact SEACON. Torque value referenced in this literature assume installation into dry metal threads. For other applications please contact SEACON for recommendations.
- Connectors are designed for installation on one atmosphere vessels. Contact SEACON for recommendations if using compensated vessels.

**ALL-WET SERIES
MAW-2-HC-BC-R/A**

ALL-WET Miniature Hermaphroditic Bulkhead Right Angle Connector
Mates with MAW-2-HC

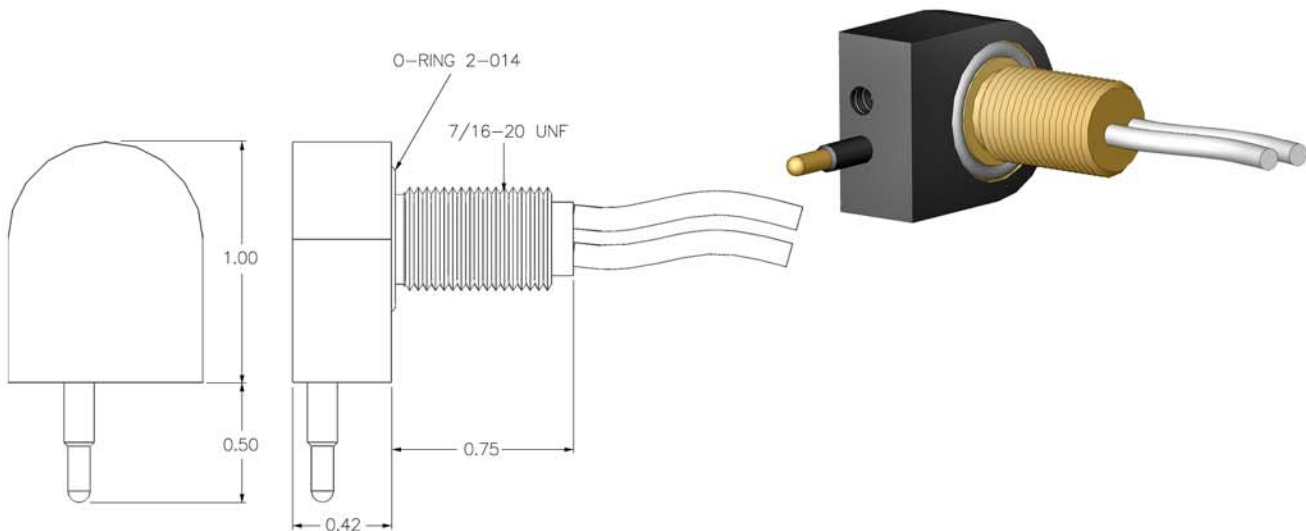

NOTES:

- Dummy connector: Optional.
- Dummy Shorting Plug: Optional.
- Connectors must be lubricated prior to mating.
- Nuts and washer supplied.
- Connectors are designed for installation on one atmosphere vessels. Contact SEACON for recommendations if using compensated vessels.

**ALL-WET SERIES
FAW-P/S-BC
THROUGH BORE OPTION**

ALL-WET Flat Bulkhead Connector

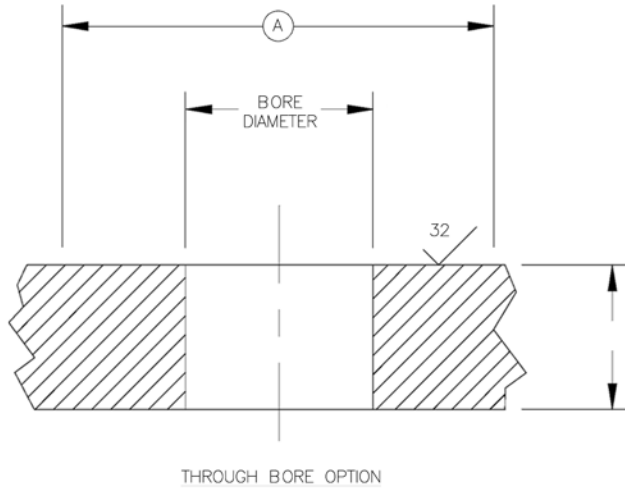

**ALL-WET SERIES
FAW-P/S-BC
THREADED MOUNTING OPTION**

ALL-WET Flat Bulkhead Connector

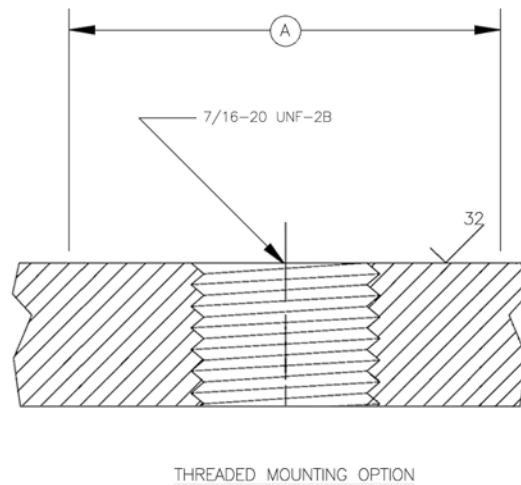

NOTES:

- A - Spot face to 32 finish, minimum diameter 1.25 (to be equal to or greater than connector diameter).
- Bore, through or threaded, must be perpendicular to spot face.
- If threaded mount is used, the lead thread chamfer is not to exceed diameter 0.450.

SIZE	ALL-WET FLAT SERIES RIGHT ANGLE BULKHEAD CONTACT CONFIGURATIONS (NOT TO SCALE)							
L								
	FAWL-2P-BC-R/A	FAWL-2S-BC-R/A	FAWL-3P-BC-R/A	FAWL-3S-BC-R/A	FAWL-4P-BC-R/A	FAWL-4S-BC-R/A	FAWL-5P-BC-R/A	FAWL-5S-BC-R/A
M								
	FAWM-8P-BC-R/A	FAWM-8S-BC-R/A	FAWM-10P-BC-R/A	FAWM-10S-BC-R/A				
SIZE	ALL-WET FLAT SERIES IN-LINE CONTACT CONFIGURATIONS (NOT TO SCALE)							
L								
	FAWL-2P-MP	FAWL-2S-MP	FAWL-3P-MP	FAWL-3S-MP	FAWL-4P-MP	FAWL-4S-MP	FAWL-5P-MP	FAWL-5S-MP
M								
	FAWM-8P-MP	FAWM-8S-MP	FAWM-10P-MP	FAWM-10S-MP				
SIZE	ALL-WET FLAT SERIES IN-LINE CONTACT CONFIGURATIONS (NOT TO SCALE)							
L								
	FAWL-2P-FS	FAWL-2S-FS	FAWL-3P-FS	FAWL-3S-FS	FAWL-4P-FS	FAWL-4S-FS	FAWL-5P-FS	FAWL-5S-FS
M								
	FAWM-8P-FS	FAWM-8S-FS	FAWM-10P-FS	FAWM-10S-FS				

HANDLING PROCEDURES AND SPECIAL CAPABILITIES

SEACON GLOBAL PRODUCTION

Callejon Terrazos #8, Local 2-C, Las Brisas 1ra. Seccion,
Tijuana, B.C., Mexico C.P. 22610.
TEL: +52 (664) 626-2726
FAX: +52 (664) 686-8922
E-Mail: sales@seaconglobal.com
Website: www.seaconglobal.com
Dial from U.S.A. TEL: +1 (619) 308-7901
TOLL FREE: (888) 562-7072
FAX: +1 (619) 308-7900

SEACON (europe) LTD

Seacon House, Hewett Road, Gapton Hall Industrial Estate,
Great Yarmouth, Norfolk, NR31 0RB, UK.
TEL: +44 (0) 1493-652733
FAX: +44 (0) 1493-652840
E-Mail: sales@seaconeurope.com
Website: www.seaconeurope.com

SEACON

1700 Gillespie Way,
El Cajon, California 92020, USA.
TEL: +1 (619) 562-7071
FAX: +1 (619) 562-9706
E-Mail: seacon@seaconworldwide.com
Website: www.seaconworldwide.com

SEACON US GULF AREA SALES OFFICE

14511 Old Katy Road, Suite 300,
Houston, Texas 77079, USA.
TEL: +1 (281) 599-3509
FAX: +1 (281) 599-3517
E-Mail: gulfcoastsales@seaconworldwide.com
Website: www.seaconworldwide.com

SEACON ADVANCED PRODUCTS, LLC

1321 Nelius Road, P.O. Box 767,
Bellville, Texas 77418, USA.
TEL: +1 (979) 865-8846
FAX: +1 (979) 865-8859
E-Mail: sales@seacon-ap.com
Website: www.seacon-ap.com

SEACON BRAZIL

Rua Conde de Bonfim 120 sala 212, Tijuca,
Rio de Janeiro, Brazil, CEP: 20520-053.
TEL: +55 (11) 2103-6262
CELL: +55 (21) 9-7626-6062
E-mail: adalberto.bromberg@te.com
Website: www.seaconworldwide.com

SEACON PHOENIX

15 Gray Lane, Suite 108, Hopkinton Industrial Park,
Ashaway, Rhode Island 02804, USA.
TEL: +1 (401) 637-4952
FAX: +1 (401) 637-4953
E-Mail: sales@seaconphoenixllc.com
Website: www.seaconphoenix.com

Even though these procedures appear simple, only qualified technicians should perform the installation and maintenance. Connectors are designed for installation on one atmosphere vessels. Contact SEACON for recommendations if using compensated vessels.

INSTALLATION PROCEDURES

Torque values referenced in this literature assume installation into dry metal threads. For other applications, please contact SEACON for recommendations.

BULKHEAD CONNECTOR (BC): The BC may be installed using one of two methods. The preferred method is to spotface the bulkhead surface and thread the hole, then screw the connector by means of a nut and washer. The bored hole (or threaded hole) should be free of any "burrs" and all o-ring sealing surfaces polished to a number 32 finish. Lubricate the BC o-ring with an appropriate silicone spray or grease before installing. This lubrication should be applied to form an adequate film. Excessive lubrication is detrimental to the operation of the connector. Bulkhead nut, if used, should not be over-torqued.

IN-LINE CONNECTOR: Lubricate the sealing areas around the male pins, using an appropriate silicone spray, or grease lightly.

CARE AND MAINTENANCE

The ALL-WET connectors require very little maintenance. They are designed to be used in harsh environments and thus limited amounts of dirt and grit do not affect their performance.

It is recommended that, upon disconnecting or retrieving the system, the connectors be cleaned, to storage (if possible, remate with dummy plugs). Prior to deployment the following maintenance procedure is recommended:

1. Demate the connector set.
2. Flush connector interface with fresh water (deionized water if available), remove all dirt, grit and grease.
3. Inspect for damage in sealing areas, excessive corrosion, debonding of the cable and connector interface and cuts in the cable jacket.
4. Apply thin film of dielectric compound (DC) grease, silicon based, to sealing areas of male connector and across the face of the female connector*. If the BC is removed from its housing then replace facial o-ring and make sure that o-rings are lubricated and in good condition.
5. Mate the connector halves, wipe away any excess grease off the interface line of the mated set.

* **CAUTION:** The use of some oil-based propellants in spray cans can cause conductivity problems in neoprene.

CABLE AND CONTINUITY PRESERVATION

Avoid sharp bends in cables. Cables subjected to vibration or exposed to seawater drag should be adequately clamped to prevent conductor fatigue and ultimate failure.

All reasonable efforts have been taken to ensure that the information contained herein is accurate at the date of publication, but no representation or warranty as to the accuracy or completeness of such information is intended or to be implied by its inclusion herein. Any and all representations and warranties pertaining to the information and products referred to herein shall be set forth in SEACON standard sales order form. In addition, SEACON reserves the right to make changes to the contents hereof without notice, therefore it is suggested that at the time of inquiry, the appropriate sales office or factory be contacted directly for verification of published specifications and products availability.

© 2017 SEACON
ALL RIGHTS RESERVED

