

Table of Contents

High Voltage DC Contactors

Quick Reference Guide	7-4, 7-5
MAP Aerospace Military Contactors	
MAP101 Series	7-6, 7-7
MAP100 Series	7-8, 7-9
MAP200 Series	7-10, 7-11
MAP201 Series	7-12, 7-13
CAP Aerospace Commercial	
CAP202 Series	7-14, 7-15
CAP200 Series	7-16, 7-17
CAP100 Series	7-18 – 7-20
EV OEM/Commercial & Electric Vehicle	
EV200A Series	7-21, 7-22
EV200B Series	7-23, 7-24
EV200P Series	7-25, 7-26
EV100 Series	7-27, 7-28
LEV Industrial Commercial	
LEV100 Series	7-29 – 7-31
LEV200 Series	7-32, 7-33

AC Contactors

FM200 Series	7-34, 7-35
AC30 Series	7-36

Traditional 270 Vdc Aerospace Contactors

AP90X Series	7-37, 7-38
AP150X Series	7-39
AP265X Series, AP265P Series	7-40
AP350X Series	7-41

Traditional 28 Vdc to 1800 Vdc Contactors

EV250 Series	7-42 – 7-45
EV500 Series	7-46, 7-47
PD350X Series	7-48

High Voltage Relays

Quick Reference Guide	7-49, 7-50
270 Vdc Aerospace Relays	
AP5A Series, AP5B Series, AP5C Series, AP5P Series, AP5R Series	7-51 – 7-53
AP10A Series, AP10B Series, AP10P Series, AP11A Series	7-51 – 7-53
AP44P Series	7-54

Table of Contents (Continued)

High Voltage Relays (continued)

28 Vdc to 1800 Vdc Relays

- PD5A Series, PD5B Series, PD5C Series7-55
- PD10A Series, PD10B Series, PD10P Series7-56

1.5 - 2.0 kV Relay

- K45C Series7-57

3.5 kV Relays

- HC-1 Series7-58
- HC-3 Series7-58
- HC-5 Series7-58

5.0 kV Relays

- K41A, K41B Series7-59
- K41C Series7-59
- K41P Series7-60
- K41R Series7-60
- K40P Series7-61
- K40P364 Series7-61

7.5 kV Relays

- KM-177-62

8.0 kV Relays

- K47A Series7-63
- K47B Series7-63
- HC-2 Series7-64
- HC-6 Series7-64
- H-18 Series7-65
- K44P Series7-66

10 kV Relays

- K81A and K81B Series7-67
- K81C Series7-68
- K43A, K43B and K43C Series7-69
- K43P and K43R Series7-70

12 kV Relays

- H-14 and H-16 Series7-71

15 kV Relays

- H-8 Series7-72
- KC-14 Series7-73
- KC-18 Series7-73
- KC-2 Series7-74
- KC-11 Series7-74
- KC-12 Series7-74
- KC-15 and KC-16 Series7-75
- H-26 Series7-76

Table of Contents (Continued)

20/25 kV Relays
 H-19 and H-17 Series7-77

25 kV Relays
 K62A, K62B and K62C Series7-78
 KC-20 Series7-79
 KC-30 Series7-79
 KC-22, KC-32 Series7-80
 KC-28, KC-38 Series7-80
 H-23 and H-24 Series7-81

35 kV Relays
 KP61 Series7-82
 K60C Series7-83
 K61A and K61B Series7-84
 K61C Series7-84

50 kV Relays
 K64C Series7-85
 H-25 Series7-85

70 kV Relays
 K70A and K70B Series7-86
 K70C Series7-86

Mounting Methods7-87

Special Connectors7-88, 7-89

Application Notes for EV/LEC Contactors7-90, 7-91

Application Notes for MAP/CAP Contactors7-92 to 7-94

Application Notes on Coil Power Economizing using PWM Circuits7-94, 7-95

KILOVAC High Voltage DC Contactors Quick Reference Guide

Product Series		(MAP) Aerospace Military			
		MAP101	MAP100	MAP200	MAP201
Main Contact Data					
Continuous Current	A	100	100	500	350
Contact Voltage Range	Vdc	12-900	12-900	12-900	12-900
Electrical Life at Rated Current, 270 Vdc, Resistive Load	Cycles	25,000	15,000	1,000	5,000
Overload (Make/Break) @ 350 Vdc	A	2,000/2,000	500/1,500	650/2,000	2,000/2,000
Rupture (Break only) @ 350 Vdc	A	2,000	1,500	2,000	2,000
Contact Arrangement		SPST	SPST	SPST	SPST
Contact Form		Latch	X (NO) or Latch	X (NO)	X (NO)
Contact Resistance @ Rated Current	milliohms	0.75	0.5	0.2	0.3
Auxiliary Contact Data					
Contact Form/Quantity of Sets (Max.)		Form A/1	Form A/1	Form A/1	Form A/1
Current Rating @ 30 Vdc (Ag/Au), Max.	A	2.0/0.1	2.0/0.1	2.0/0.1	2.0/0.1
Minimum Signal Level	Vdc/mAdc	Ag 6V/15mA Au 5V/5mA	Ag 6V/15mA Au 5V/5mA	Ag 6V/15mA Au 5V/5mA	Ag 6V/15mA Au 5V/5mA
Dielectric Withstanding Voltage					
Contacts to Coil to All Other Points	Vrms	1,500	1,500	2,200	2,200
Insulation Resistance					
Initially @ 500 Vdc	megohms	100	100	100	100
At End of Life @ 500 Vdc	megohms	50	50	50	50
Environmental Data					
Operating Temperature Range	°C	-55 to +85	-55 to +85	-55 to +85	-55 to +85
Storage Temperature Range	°C	-65 to +125	-65 to +125	-65 to +125	-65 to +125
Shock, 11ms, 1/2 Sine	G's	20	20	20	20
Vibration, Sine (55-2,000 Hz)	G's	20	20	20	20
Coil Transient Suppression					
		No	X, Yes/Latch, No	Yes	Yes
Mechanical Data					
Operate Time @ 25°C (Including Bounce), Max./Typ.	ms	40/20	40/20	40/20	40/20
Release Time, Max.	ms	15	15	15	15
Bounce Time, Max.	ms	5	5	5	5
Mechanical Life, Min.	Cycles	100,000	100,000	100,000	100,000
Weight (Nominal)	lb. (kg)	0.79 (.35)	0.79 (.35)	0.95 (.43)	0.95 (.43)
Coil Voltage (Nominal)					
	Vdc	28	28	28	28

Note: Consult TE Connectivity for complete specifications, detailed performance characteristics and additional models.

For factory-direct application assistance,
dial 800-253-4560, ext. 2055, or
805-220-2055.

KILOVAC High Voltage DC Contactors Quick Reference Guide (Continued)

(CAP) Aerospace Commercial			(EV) OEM/Commercial & Electric Vehicle				(LEV) Industrial Commercial	
CAP202	CAP200	CAP100	EV200A	EV200B	EV200P	EV100	LEV100	LEV200
300	500	100	500	500	500	100	100	500
12-900	12-900	12-900	12-900	12-900	12-900	12-900	900	12-900
10,000	1,000	6,000	1,000	500	500	6,000	6,000	1,000
650/2,000	650/2,000	600/1000	650/2000	650/1000	650/1000	600/1000	600/1000	650/2000
2,000	2,000	1000	2000	1000	1000	1000	1000	1000
DPST	SPST	SPST	SPST	SPST	SPST	SPST	SPST	SPST
2X (NO)	X (NO)	X (NO)	X(NO)	Y(NC)	X (LATCH)	X(NO)	X(NO)	X(NO)
0.2	0.2	0.2	0.2	0.2	0.2	0.2	0.2	0.2
Form C/4	Form A/2	Form C/1	Form A/1	Form A/1	Form A/1	None	Form X/1	Form X/1
2.0/0.1	2.0/0.1	2.0/0.1	2.0/0.1	2.0/0.1	2.0/0.1	2.0/0.1	2.0/0.1	2.0/0.1
Ag 6V/15mA Au 5V/5mA	Ag 6V/15mA Au 5V/5mA	Ag 6V/15mA Au 5V/5mA	Ag 6V/15mA Au 5V/5mA	Ag 6V/15mA Au 5V/5mA	Ag 6V/15mA Au 5V/5mA	—	—	Ag 6V/15mA Au 5V/5mA
2,200	2,200	2,200	2,200	2,200	2,200	2,200	2,000	2,200
100	100	100	100	100	100	100	100	100
50	50	50	50	50	50	50	50	50
-55 to +85	-55 to +85	-55 to +85	-40 to +85	-40 to +60	-40 to +85	-40 to +85	-40 to +85	-40 to +85
-65 to +125	-65 to +125	-65 to +125	-65 to +125	-65 to +125	-65 to +125	-65 to +125	-65 to +125	-65 to +125
30	20	20	20	30 (Closed)/ 10 (Open)	30	20	20	20
20	20	20	20	10	20	20	20	20
Yes	Yes	Yes	Yes	Yes	No	Yes	No	No
40/20	40/20	25/15	25/15	25/15	25/15	25/15	25/15	25
15	15	10	12	15	15	15	10	15
5	5	5	7	5	5	5	5	5
100,000	100,000	100,000	1,000,000	100,000	100,000	1,000,000	1,000,000	100,000
1.3 (.59)	0.95 (.43)	6.70 (190)	0.95 (.43)	0.95 (.43)	.99 (.53)	.28 (.130)	0.42 (.19)	1.3 (.60)
28	28	28	9-36	12/24	12/24	9-36	12/24/48	12/24/48

For factory-direct application assistance,
dial 800-253-4560, ext. 2055, or
805-220-2055.

KILOVAC MAP101 Series Contactor with 1 Form A (SPST-NO) Contacts Rated up to 100 Amps, 12-900 Vdc Dual Contact Material (Cu/Mo)

Product Facts

- Dual contact material (copper/moly) designed for high current make and interrupt military aerospace, ground vehicle and naval applications
- Hermetically sealed, intrinsically safe, operates in explosive/harsh environments with no oxidation or contamination of coils or contacts, during long periods of non-operation
- Comes standard with 1 SPST-NO Aux. contact
- Not position sensitive, can be mounted in any orientation
- RoHS versions available



Physical Data

Contact Arrangement —
Main Contacts —
SPST-Latching (form X)
1X Auxiliary Contact —
SPST-NO (form A)

Dimensions — See drawing

Weight, Nominal —
0.35 Kg (12.35 oz)

Environmental Data

Shock, 11ms 1/2 Sine (Operating) — 20 G_{peak}

Sine Vibration, 20 G_{peak} —
55-2000 Hz

Random Vibration, 14.06 Grms —
15 Hz (.002 G²/Hz), 100 Hz (.002 G²/Hz),
450 Hz (.12 G²/Hz), 900 Hz (.12 G²/Hz),
2000 Hz (.083 G²/Hz)

Operating Temperature Range —
-55°C to +85°C

Electrical Data

Voltage Rating —
Main Contacts (max) — 400 Vdc
Auxiliary Contacts — 30 Vdc

Current Rating, Continuous —
Main Contacts 1 — 100 A
Auxiliary Contacts — 3 A

Contact Resistance —
Main Contacts —
100 mΩ max @ 1 amp
0.75 mΩ max @ rated current
Auxiliary Contacts —
200 mΩ max

Electric Life at Rated Current 270 Vdc, Resistive Load —
25,000 cycles

Mechanical Life — 1 million cycles

Dielectric Withstand Voltage —
Terminal to Terminal/ Terminals to Coil —
1mA max @ 1,300Vrms

Coil Data

Coil Voltage, Nominal/ Max —
28/ 32 Vdc

Coil Resistance @ 25°C —
Contacts Close Coil — 18 Ω
Contacts Open Coil — 13 Ω

Pick Up/ Drop Out (Max) —
16 Vdc (-55°C to +25°C)
18 Vdc (+25°C to +85°C)

Coil Current (Max) @ 32Vdc/ -40°C — 4.0 A

Coil Current On Time (Minimum Required to Latch) — 40 ms

Main Contacts —
Operate Time (Max) — 40 ms
Operate Bounce (Max) — 5 ms
Release Time — 25 ms

Auxiliary Contacts Operate/ Release — Within ± 5 ms of main

Insulation Resistance —
Terminal to Terminal/ Terminals to Coil —
100MΩ min @ 500Vdc new
50MΩ min @ 500Vdc end of life

Note:

1 Continuous current rating is affected by conductors attached. Keep terminals below 150°C max continuous.

Ordering Information

Typical Part Number ►

MAP101 R B A F E

Series: _____
MAP101 = 100 Amp, 12-900VDC Contactor

Dual Contact Material

Contact Form: _____
R - Latch with 1 SPST NO Aux.

Coil Voltage: _____
B = 28 Vdc Coil

Lead Length: _____
A = 15.3 in. (300 mm)

Coil Terminal Connector: _____
N = None
F = Plug on Flying Lead, 9 Pin Micro-D

Mounting & Power Terminals _____
E = side mount with 2x#8
10-32 Female Power Terminals

For factory-direct application assistance, dial 800-253-4560, ext. 2055, or 805-220-2055.

KILOVAC MAP101 Series Contactor (Continued)

Outline Dimensions

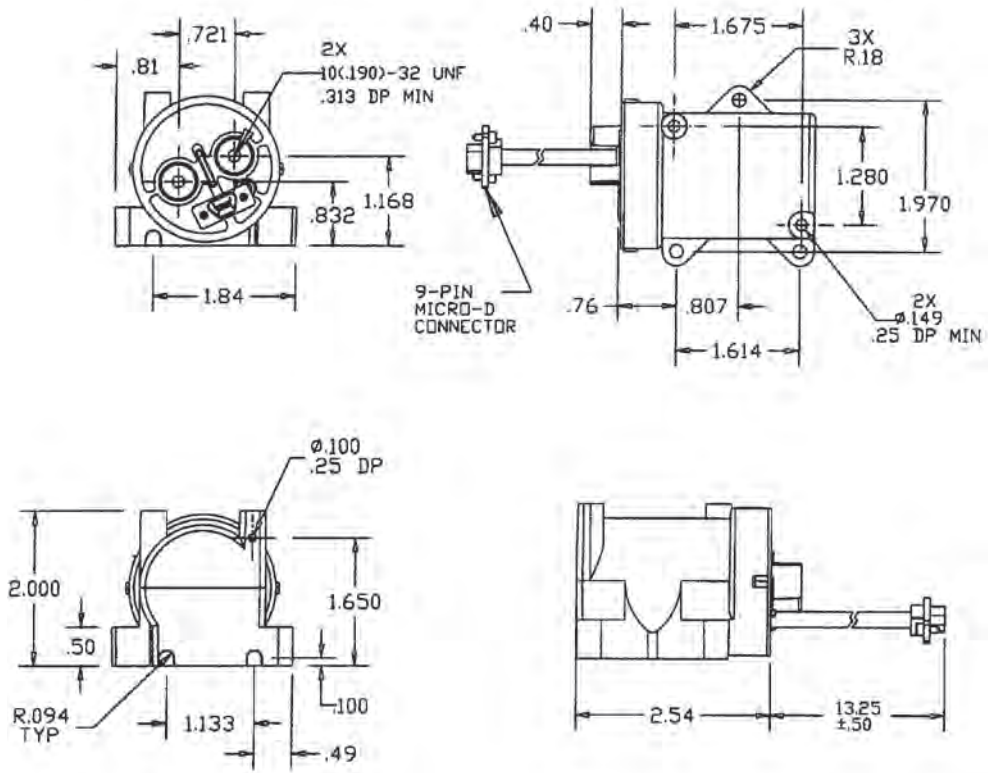

Connector Pin-Out

1	Not Connected
2	Aux. NO
3	Close Return
4	Close Return
5	+28Vdc
6	Aux. Com.
7	Open Return
8	Open Return
9	+28V

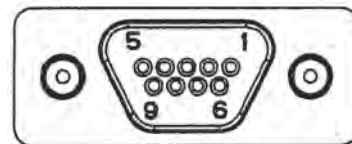

For factory-direct application assistance,
 dial 800-253-4560, ext. 2055, or
 805-220-2055.

KILOVAC MAP100 Series Contactor with 1 Form A (SPST-NO) Contacts Rated up to 100 Amps, 12-900 Vdc

Product Facts

- Solid copper contacts designed for high current carry military aerospace, ground vehicle and naval applications
- Hermetically sealed, intrinsically safe, operates in explosive/harsh environments with no contact oxidation or contamination of coil or contacts, during long periods of non- operation
- Comes standard with 1 SPST-NO Aux. contact
- Not position sensitive, can be mounted in any orientation
- RoHS versions available



Physical Data

Contact Arrangement —
Main Contacts —
SPST-Latching (or NO Form X)
1X Auxiliary Contact —
SPST-NO (form A)

Dimensions — See drawing

Weight, Nominal —
0.35 Kg (12.35 oz)

Environmental Data

Shock, 11ms 1/2 Sine (Operating) — 20 G_{peak}

Sine Vibration, 20 G_{peak} —
55-2000 Hz

Random Vibration, 14.06 Grms —
15 Hz (.002 G²/Hz), 100 Hz (.002 G²/Hz),
450 Hz (.12 G²/Hz), 900 Hz (.12 G²/Hz),
2000 Hz (.083 G²/Hz)

Operating Temperature Range —
-55°C to +85°C

Electrical Data

Voltage Rating —
Main Contacts (max) — 400 Vdc
Auxiliary Contacts — 30 Vdc

Current Rating, Continuous —
Main Contacts 1 — 100 A
Auxiliary Contacts — 3 A

Contact Resistance —
Main Contacts —
100 mΩ max @ 1 amp
0.75 mΩ max @ rated current
Auxiliary Contacts —
200 mΩ max

Electrical Life at Rated Current, 270 Vdc, Resistive Load —
15,000 cycles

Mechanical Life — 1 million cycles

Dielectric Withstand Voltage —
Terminal to Terminal/ Terminals to Coil —
1mA max @ 1,300Vrms

Insulation Resistance —
Terminal to Terminal/ Terminals to Coil —
100MΩ min @ 500Vdc new
50MΩ min @ 500Vdc end of life

Note:

1 Continuous current rating is affected by conductors attached. Keep terminals below 150°C max continuous.

Coil Data

Coil Voltage, Nominal/ Max —
28/ 32 Vdc

Coil Resistance @ 25°C —
Contacts Close Coil — 18 Ω
Contacts Open Coil — 13 Ω

Pick Up/ Drop Out (Max) —
16 Vdc (-55°C to +25°C)
18 Vdc (+25°C to +85°C)

Coil Current (Max) @ 32Vdc/ -40°C — 4.0 A

Coil Current On Time (Minimum Required to Latch) — 40 ms

Main Contacts —
Operate Time (Max) — 40 ms
Operate Bounce (Max) — 5 ms
Release Time — 25 ms

Auxiliary Contacts Operate/ Release — Within ± 5 ms of main

Ordering Information

Typical Part Number ►

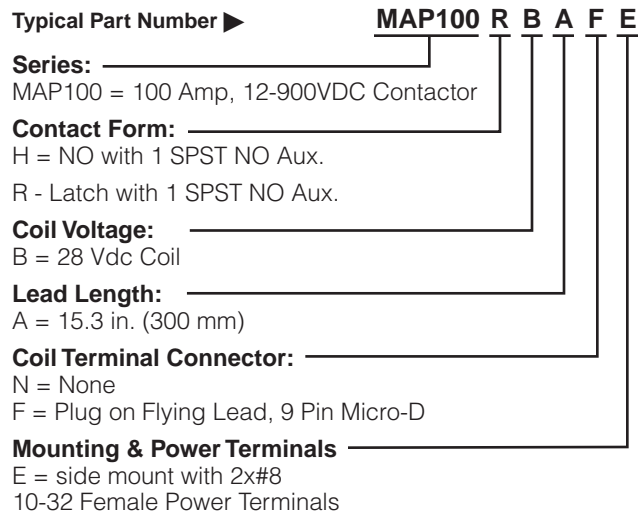

For factory-direct application assistance,
dial 800-253-4560, ext. 2055, or
805-220-2055.

KILOVAC MAP100 Series Contactor (Continued)

Outline Dimensions

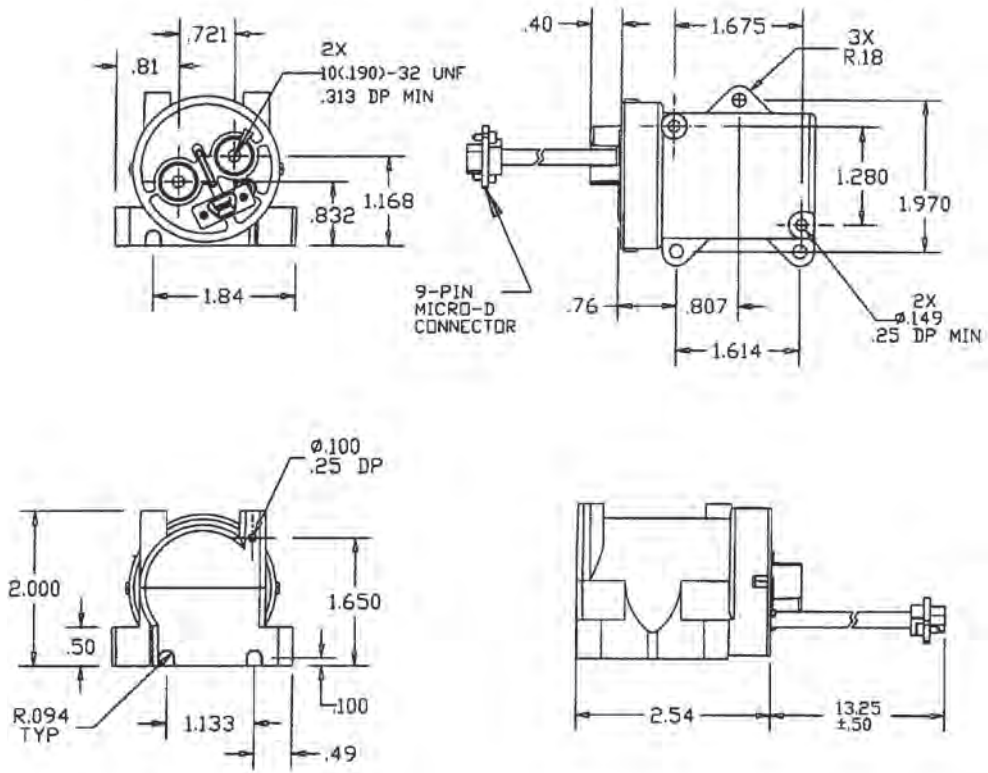

Connector Pin-Out

1	Not Connected
2	Aux. NO
3	Close Return
4	Close Return
5	+28Vdc
6	Aux. Com.
7	Open Return
8	Open Return
9	+28V

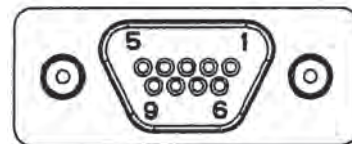

For factory-direct application assistance, dial 800-253-4560, ext. 2055, or 805-220-2055.

KILOVAC MAP200 Series Contactor with 1 Form A (SPST-NO) Contacts Rated up to 500 Amps, 12-900 Vdc

Product Facts

- Designed to be the smallest, lightest weight, lowest cost sealed contactor in the industry with its current rating for military aerospace, ground vehicle and naval, high current applications
- Built-in coil economizer (models requiring external economizer also available)
- Optional auxiliary contact for easy monitoring of power contact position
- Hermetically sealed — intrinsically safe, operates in explosive/harsh environments with no oxidation or contamination of coil or contacts, including long periods of non-operation
- Versatile coil and power connections
- RoHS versions available



Performance Data

Contact Arrangement, Power Contacts — 1 Form A (SPST-NO)

Rated Operating Voltage — 12 - 900 VDC

Continuous (Carry) Current, Typical — 500 A @ 85°C, 400 mcm conductors

Consult Factory for required conductors for higher currents

Make/Break Current at Various Voltages ¹ — See graph next page

Break Current at 320VDC ¹ — 2,000 A, 1 cycle

Contact Resistance, Typ. (@200A) — 0.2 mohms

Load Life — See graph next page

Mechanical Life — 1 million cycles

Contact Arrangement, Auxiliary Contacts — 1 Form A (SPST-NO)

Aux. Contact Current, Max. — 2A @ 30VDC / 3A @ 125VAC

Aux. Contact Current, Min. — 100mA @ 8V

Aux. Contact Resistance, Max. — 0.417 ohms @ 30VDC / .150 ohms @ 125VAC

Dielectric Withstanding Voltage — 2,200 Vrms @ sea level

Insulation Resistance @ 500VDC — 100 megohms ²

Shock, 11ms 1/2 Sine, Peak, Operating — 20 G

Vibration, Sine, 50-2000Hz., Peak — 20 G

Operating Temperature — -55°C to +85°C

Weight, Nominal — .95 lb. (.43 kg)

Notes:

- ¹ Main power contacts
- ² 50 at end of life

Coil Operating Voltage (Valid Over Temperature Range)	
Voltage (Will Operate)	18-32VDC
Voltage (Max.)	32VDC
Pickup (Close) Voltage Max.	18VDC
Hold Voltage (Min.)	10VDC
Dropout (Open) Voltage (Min.)	2VDC
Inrush Current (Max.)	4.5A
Holding Current (Avg.)	0.5A
Inrush Time (Max.)	100ms

Ordering Information

Typical Part Number ►

MAP200 A R D E A

Series: _____
MAP200 = 500 Amp, 12-900VDC Contactor

Contact Form: _____
A = Normally Open
H = Normally Open with Aux. Contacts

Coil Voltage: _____
R = 28 Vdc, Mechanical Economizer
S = 28 Vdc, Electrical Cut-throat Economizer

Coil Wire Length: _____
A = 15.3 in (390 mm)
D = Coil connector on relay (requires option "E" or "X" in next step).

Coil Terminal Connector: _____
N = No connector
E = 9-pin subminiature "D" plug mounted on contactor housing
X = Special configuration (consult factory)

Mounting & Power Terminals: _____
A = Bottom Mount & Male M8 x 1.25 Thread Terminals
B = Bottom Mount & Female 1/4-20 Thread Terminals
D = Bottom Mount & Female M6 x 1 Thread Terminals

For factory-direct application assistance, dial 800-253-4560, ext. 2055, or 805-220-2055.

KILOVAC MAP200 Series (Continued)

Outline Dimensions

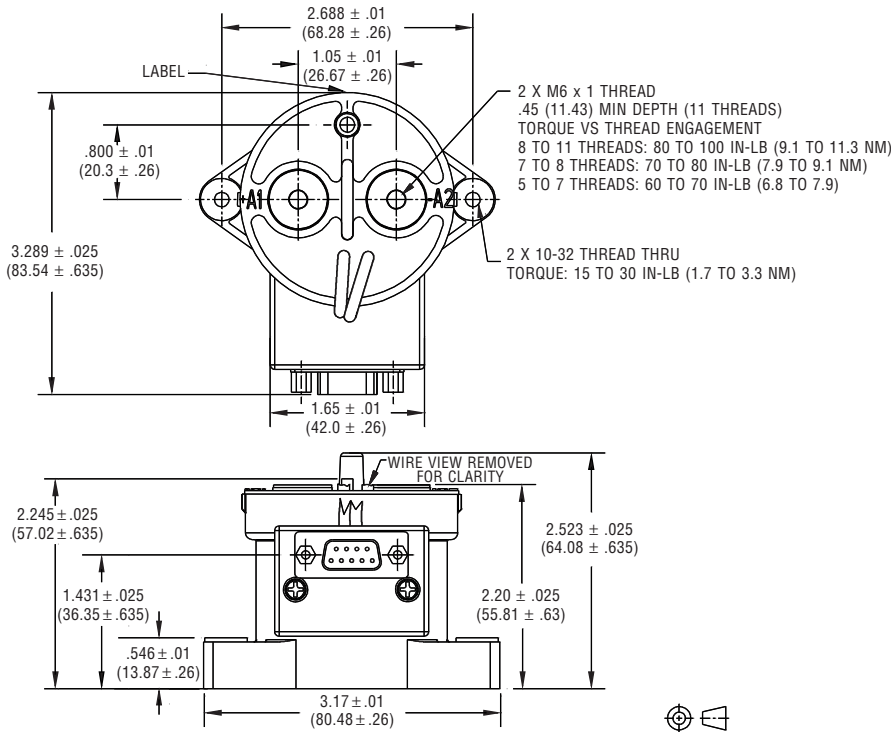

**MAP200HR D-Sub
Pin Out**

- Coil+ = Pin 2
- Coil - = Pin 6
- Aux. COM = Pin 8
- Aux. NO = Pin 4

MAP200AR

- Coil+ = Pin 2
- Coil - = Pin 6

Estimated Make & Break Power Switching Ratings

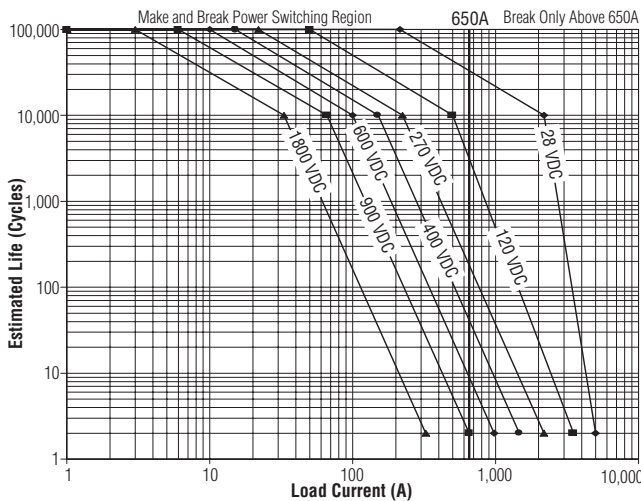

NOTES:

- 1) For resistive loads with 300µH maximum inductance. Consult factory for inductive loads.
- 2) Estimates based on extrapolated data. User is encouraged to confirm performance in application.
- 3) End of life when dielectric strength between terminals falls below 50 megohms @ 500VDC.
- 4) The maximum make current is 650A to avoid contact welding.

For factory-direct application assistance,
dial 800-253-4560, ext. 2055, or
805-220-2055.

KILOVAC MAP201 Series Contactor with 2 Form A (SPST-NO) Contacts Rated up to 350 Amps, 12-900 Vdc Dual Contact Material (Cu/Mo)

Product Facts

- Designed to be the smallest, lightest weight, lowest cost sealed contactor in the industry with its current rating for military aerospace
- Built-in coil economizer (models requiring external economizer also available)
- Optional auxiliary contact for easy monitoring of power contact position
- Hermetically sealed — intrinsically safe, operates in explosive/harsh environments with no oxidation or contamination of coil or contacts, including long periods of non-operation
- Versatile coil and power connections
- RoHS versions available



Physical Data

Contact Arrangement —
Power Contacts —
SPST-NO (form X)
2X Auxiliary Contacts 1 —
SPST-NO (form A)
Dimensions — See drawing
Weight, Nominal — 0.45 Kg (0.99 lb)

Environmental Data

Shock, 11ms 1/2 Sine (Operating) — 20 G_{peak}
Sine Vibration, 20 G_{peak} —
55-2000 Hz
Random Vibration, 14.06 Grms —
15 Hz (.002 G²/Hz), 100 Hz (.002 G²/Hz),
450 Hz (.12 G²/Hz), 900 Hz (.12 G²/Hz),
2000 Hz (.083 G²/Hz)
Operating Temperature Range —
-55°C to +85°C

Electrical Data

Voltage Rating —
Main Contacts (max) — 400 Vdc
Auxiliary Contacts — 30 Vdc
Current Rating, Continuous —
Main Contacts 2 — 300 A
Auxiliary Contacts — 3 A
Contact Resistance —
Main Contacts 3 —
100 mΩ max @ 1 amp
0.3 mΩ max @ rated current
Auxiliary Contacts —
200 mΩ max
Hot Switching Performance (Polarity Sensitive) —
600A make/ 265A break @ ± 270Vdc —
11,000 cycles
550A make/ break @ ± 360Vdc —
100 cycles
2000A capacitive make — 100 cycles
2000A make/ break @ +360Vdc —
5 cycles
1000A make/ break @ -360Vdc —
2 cycles
Mechanical Life — 1 million cycles
Dielectric Withstand Voltage —
Terminal to Terminal/ Terminals to Coil —
1mA max @ 2,200Vrms

Coil Data

Coil Voltage, Nominal/ Max —
28/ 32 Vdc
Pick Up (Max) — 16 Vdc
Inrush Current @ 28Vdc (Max) —
3.5 A
Inrush Time (Max) — 100 ms
Hold Current (Max) — 0.32 A
Drop Out — 4 to 10 Vdc
Main Contacts —
Operate Time (Max) — 18 ms
Operate Bounce (Max) — 5 ms
Release Time — 18 ms
Auxiliary Contacts Operate/ Release — Within ± 5 ms of main

Insulation Resistance —
Terminal to Terminal/ Terminals to Coil —
100MΩ min @ 500Vdc

Notes:

- 1 Two form A available with electronic coil economizer, 1 form A available with mechanical coil economizer
- 2 Continuous current rating is affected by conductors attached. Keep terminals below 150°C max continuous, 175C for 1 hour max, and 200C for 1 minute max.
- 3 Initial contact resistance may be higher than 0.3mΩ, but will drop below within 30 minutes maximum

Ordering Information

Typical Part Number ► **MAP201 A R D E A**

Series: _____
MAP201 = 350 Amp, 12-900VDC Contactor

Contact Form: _____
A = Normally Open
H = Normally Open with Aux. Contacts

Coil Voltage: _____
R = 28 Vdc, Mechanical Economizer
S = 28 Vdc, Electrical Cut-throat Economizer

Coil Wire Length: _____
A = 15.3 in (390 mm)
D = Coil connector on relay (requires option "E" or "X" in next step).

Coil Terminal Connector: _____
N = No connector
E = 9-pin subminiature "D" plug mounted on contactor housing
X = Special configuration (consult factory)

Mounting & Power Terminals: _____
A = Bottom Mount & Male M8 x 1.25 Thread Terminals
B = Bottom Mount & Female 1/4-20 Thread Terminals
D = Bottom Mount & Female M6 x 1 Thread Terminals

For factory-direct application assistance, dial 800-253-4560, ext. 2055, or 805-220-2055.

KILOVAC MAP201 Series Contactor (Continued)

Outline Dimensions*

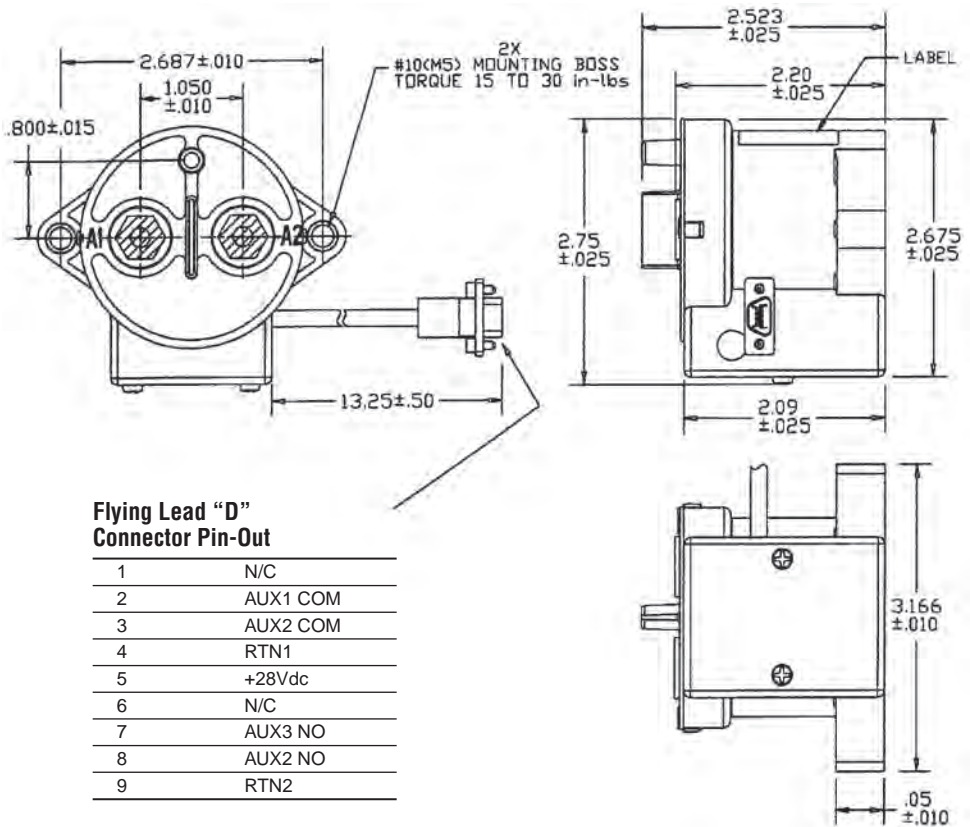

Flying Lead "D" Connector Pin-Out

1	N/C
2	AUX1 COM
3	AUX2 COM
4	RTN1
5	+28Vdc
6	N/C
7	AUX3 NO
8	AUX2 NO
9	RTN2

MAP200HR D-Sub Pin Out

Coil+ = Pin 2
 Coil - = Pin 6
 Aux. COM = Pin 8
 Aux. NO = Pin 4

MAP200AR

Coil+ = Pin 2
 Coil - = Pin 6

***Alternate coil and main terminal connections available, consult factory.**

For factory-direct application assistance, dial 800-253-4560, ext. 2055, or 805-220-2055.

KILOVAC CAP202 Series Aerospace Commercial Contactor with 2 Form X (DPST-NO), Contacts Rated up to 300 Amps, 12-600 Vdc

Product Facts

- Hermetically sealed
- Up to 4X SPDT auxiliary switch outputs: 30 Vdc/2A max switching or 6V/5mA min. signal
- Integrated coil economizer with coil suppression
- EMC compliant - no radiated coil emission
- Bidirectional switching - main contacts not polarity sensitive
- Mount in any orientation - not position sensitive



Description

2-pole single throw hermetically sealed DC contactor; 12-900 Vdc/350A per pole

Not position sensitive

Bi-directional switching

Applications

High Voltage DC Converter Systems (ref schematic below)

Test Equipment

Power Distribution

Power Motion Control

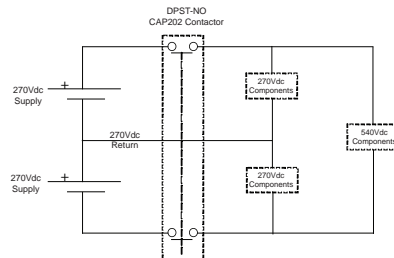

Electrical

Compact epoxy-sealed resin enclosure occupies only about 4 in³ (65.5 cm³)

Contact arrangement: DPST-No (2 form X)

Voltage rating: 12-900 Vdc (main contacts); 30 Vdc (auxiliary)

Mechanical life: 100,000 cycles

Physical or Other Properties

Weight: 0.79 Kg

Hermetically sealed

Safe for harsh/corrosive environments

No contacts oxidation over periods on non-use

Number of SPDT Auxiliary Contacts per Contactor Type:
CAP202AS — None
CAP202MS — Two
CAP202FS — Four

Performance Data

Physical Data

Contact Arrangement — Power Contacts — DPST-NO (2 Form X)
Auxiliary Switches — SPDT (form C)

Dimensions — See drawings on next page

Weight — 0.79 Kg (1.74 lb.)

Electrical Data

Voltage Rating — Main Contacts — 12-900Vdc
Auxiliary Contacts — 30Vdc

Current Rating — Main Contacts¹ — 350A/pole
Auxiliary Contacts — 3A

Contact Resistance — Main Contacts — (2)
100 mΩ max @ 1 amp
0.3 mΩ max. @ 200A after 3 mins.
Auxiliary Contacts — 200 mΩ max

Hot Switching Performance @ ± 400 Vdc (3) —

100A make/break — 10,000 cycles
250A make/break — 2,500 cycles
700A break only — 10 cycles

Hot Switching Performance @ ± 270 Vdc (4) —

100A make/break — 40,000 cycles
250A make/break — 7,500 cycles
2000A break only @ ±370Vdc (5) — 2 cycles

Maximum Make Current — 700A

Dielectric Withstand Voltage over Life — Terminal to Terminal/Terminals to Coil — 1mA max @ 2,200Vrms

Insulation Resistance over Life — Terminal to Terminal/Terminals to Coil — 50mΩ min @ 500Vdc

Mechanical Life — 100,000 cycles

Environmental Data

Shock, 11ms 1/2 sine (operating) — 20G peak

Sine Vibration, 10G peak — 55-2,000 Hz.

Random Vibration, 14 Grms —

15	100	300	900	2000 Hz
.01	.01	.2	.2	.01 G2/Hz

Operating Temperature Range — -55°C to +85°C

Notes:

¹ Using 4/0 conductor. Current rating is affected by attached conductor size and design. Keep terminals below 150°C max. continuous, 175°C for 2 hours max. and 200°C for 1 minute max. For mounting large conductors, request terminal adapter PN 3-1618396-7.

² Operational contact resistance is measured by millivolt drop across contacts at a > 100A current. Initial contact resistance may be higher than 0.3mΩ, but will drop below within 30 mins. max.

³ Voltage applied to each contact set separately.

⁴ Voltage applied across both contact sets in series.

⁵ May not pass 2,200 Vrms dielectric testing after second interrupt cycle.

For factory-direct application assistance, dial 800-253-4560, ext. 2055, or 805-220-2055.

KILOVAC CAP202 Series 12-900Vdc Contactors

Outline Dimensions*

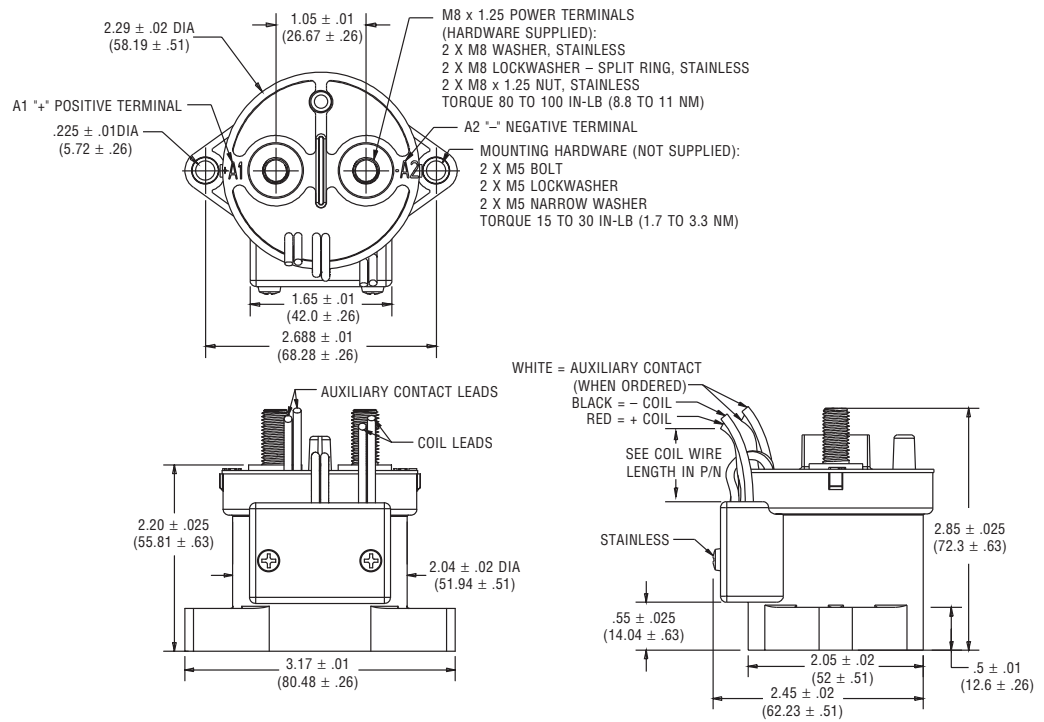

Coil Data (-40 to +85°C temp range unless otherwise noted)	
Voltage/Nominal Max.	28-32VDC
Pickup Voltage Max.	16VDC
Inrush Current @ 28 Vdc nominal / @32V maximum	3.4/6.0A
Inrush Time (nominal/maximum)	75/150mS
Hold Current @28V nominal / @32V maximum	0.27/0.48A
Drop Out Voltage	3 to 8Vdc
Internal Coil Suppression (max.)	60Vdc
Main Contacts: Operate Time, nominal/maximum	13/20mS
Main Contacts: Operate Bounce, nominal/maximum	3/10mS
Main Contacts: Release Time, nominal/maximum	25mS
Main Contacts: Release Time, maximum including Maximum arc time	7/12mS

Ordering Information

Typical Part Number ▶

CAP202 M S B F D

Series: CAP202 = 2 form X, DPST-N0-DM Contactor

Auxiliary Contact Outputs (SPDT form C):

- A = None
- M = Two
- F = Four

Coil Voltage: S = 28V (with built-in electronically switched dual coil economizer)

Coil and Aux. Wire Length:

- A = 15.3 inches
- B = 6 inches
- X = Customer Special

Coil and Aux. Connector: N = None
 F = D Plug on flying leads (may affect wire length)

Mounting & Power Terminals: D = 2X M5 Bottom Mount with 4X, M6 x 1 Female thread terminals

Specifications are subject to change without notice.

For factory-direct application assistance, dial 800-253-4560, ext. 2055, or 805-220-2055.

KILOVAC CAP200 Series Contactor with 1 Form A (SPST-NO) Contacts Rated up to 500 Amps, 12-900 Vdc

Product Facts

- Designed to be the smallest, lightest weight, lowest cost sealed contactor in the industry with its current rating
- Built-in coil economizer — only 1.7W hold power @ 12VDC and it limits back EMF to 0V. (models requiring external economizer also available)
- Optional auxiliary contact for easy monitoring of power contact position
- Hermetically sealed — intrinsically safe, operates in explosive/harsh environments with no oxidation or contamination of coil or contacts, including long periods of non-operation
- Versatile coil and power connections
- RoHS versions available



Coil Operating Voltage (Valid Over Temperature Range)			
Voltage (Will Operate)	9-36VDC	32-95VDC	48-95VDC
Voltage (Max.)	36VDC	95VDC	95VDC
Pickup (Close) Voltage Max.	9VDC	32VDC	48VDC
Hold Voltage (Min.)	7.5VDC	22VDC	34VDC
Dropout (Open) Voltage (Min.)	6VDC	18VDC	27VDC
Inrush Current (Max.)	3.8A	1.3A	0.7A
Holding Current (Avg.)	0.13A@12V, 0.07A@24V	0.03A@48V	0.02A@72V
Inrush Time (Max.)	130ms	130ms	130ms

Ordering Information

Typical Part Number ►

CAP200 A A A N A

Series: _____
CAP200 = 500 Amp, 12-900VDC Contactor

Contact Form: _____
A = Normally Open
H = Normally Open with Aux. Contacts

Coil Voltage: _____
A = 9-36VDC (1 = requires external coil economizer)
D = 32-95VDC (2 = requires external coil economizer)
J = 48-95VDC (3 = requires external coil economizer)
R = 28 Vdc with mechanical economizer

Coil Wire Length: _____
A = 15.3 in (390 mm)
D = Coil connector on relay (requires option "E" or "X" in next step)

Coil Terminal Connector: _____
N = None
E = 9-pin subminiature "D" plug mounted on contactor housing
F = 9-pin subminiature "D" plug mounted on 15.3 in (390 mm) flying leads.
X = Special configuration (consult factory)

Mounting & Power Terminals: _____
A = Bottom Mount & Male 10mm x 8 Terminals

Performance Data

Contact Arrangement, Power Contacts — 1 Form A (SPST-NO)

Rated Operating Voltage — 12 - 900 VDC

Continuous (Carry) Current, Typical — 500 A @ 85°C, 400 mcm conductors

Consult Factory for required conductors for higher currents

Make/Break Current at Various Voltages ¹ — See graph next page

Break Current at 320VDC ¹ — 2,000 A, 1 cycle ³

Contact Resistance, Typ. (@200A) — 0.2 mohms

Load Life — See graph next page

Mechanical Life — 1 million cycles

Contact Arrangement, Auxiliary Contacts — 1 Form A (SPST-NO)

Aux. Contact Current, Max. — 2A @ 30VDC / 3A @ 125VAC

Aux. Contact Current, Min. — 100mA @ 8V

Aux. Contact Resistance, Max. — 0.417 ohms @ 30VDC / .150 ohms @ 125VAC

Dielectric Withstanding Voltage — 2,200 Vrms @ sea level

Insulation Resistance @ 500VDC — 100 megohms ²

Shock, 11ms 1/2 Sine, Peak, Operating — 20 G

Vibration, Sine, 80-2000Hz., Peak — 20 G

Operating Temperature — -40°C to +85°C

Weight, Nominal — .95 lb. (.43 kg)

Notes:

¹ Main power contacts

² 50 at end of life

³ Does not meet dielectric & IR after test, 1700 amp for unit with Aux. Contacts

For factory-direct application assistance, dial 800-253-4560, ext. 2055, or 805-220-2055.

KILOVAC CAP200 Series (Continued)

Outline Dimensions

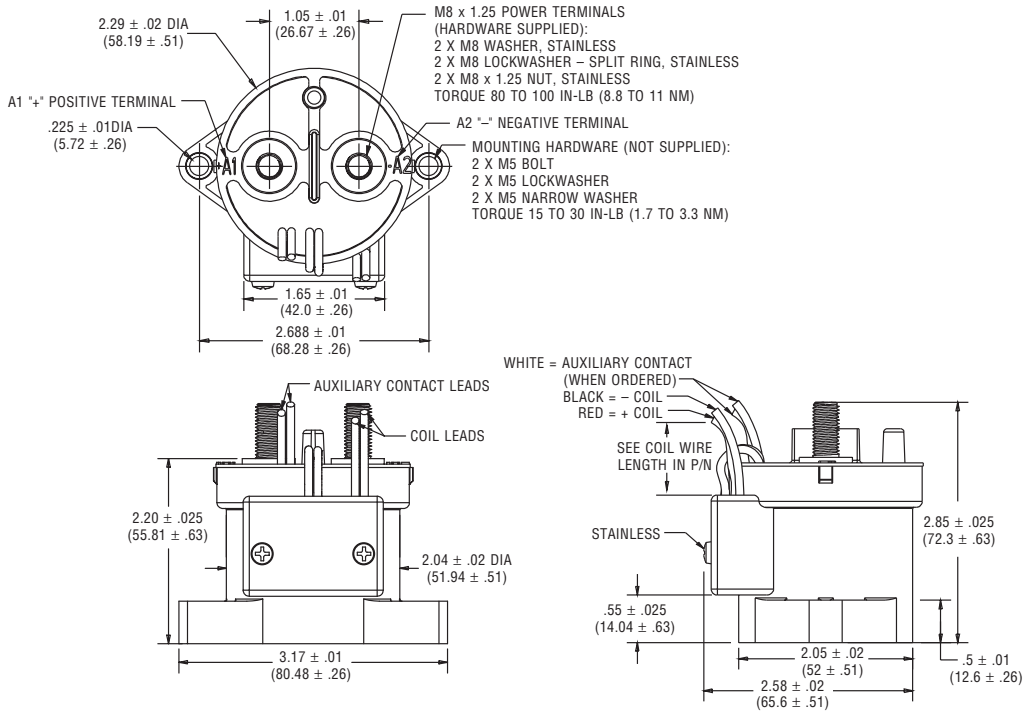

Estimated Make & Break Power Switching Ratings

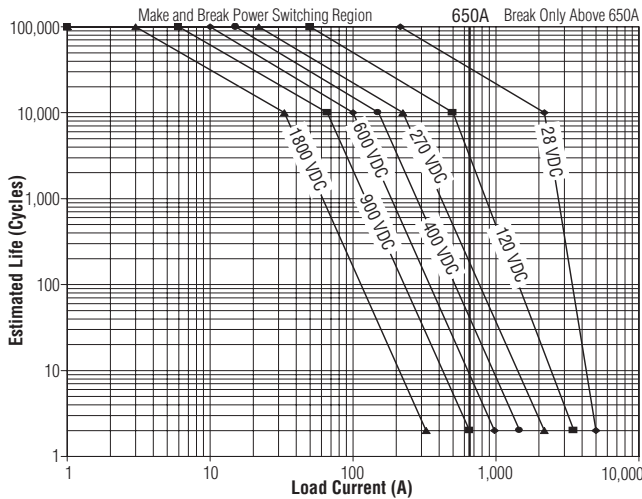

NOTES:

- 1) For resistive loads with 300µH maximum inductance. Consult factory for inductive loads.
- 2) Estimates based on extrapolated data. User is encouraged to confirm performance in application.
- 3) End of life when dielectric strength between terminals falls below 50 megohms @ 500VDC.
- 4) The maximum make current is 650A to avoid contact welding.

For factory-direct application assistance,
 dial 800-253-4560, ext. 2055, or
 805-220-2055.

KILOVAC CAP100 Series 900 Vdc Contactor

Product Facts

- Commercial aerospace product
- Hermetically sealed — intrinsically safe. Operates in explosive/harsh environments without oxidation or contamination of contacts, during long periods of non-operation
- 8kV isolation between open contacts permits use for high voltage isolation and carry, optional auxiliary contacts
- 12, 24 and 48 Vdc coils
- Solid copper contacts
- Designed and built in accordance to AIAG QS9000
- RoHS versions available



Description

Lowest cost, 900 Vdc 100 amp, hermetically sealed DC contactor in the industry with coil suppression and 1 Form C Aux. contact

Compact package available in side- or bottom-mount reinforced configurations, not position sensitive

Applications

Power/motor control circuit isolation, circuit protection and power distribution

Commercial Aerospace

Mechanical

Compact epoxy-sealed resin enclosure occupies only about 4 in³ (65.5 cm³)

Robust integral mounting plate on either bottom or side of enclosure accepts two M4 screws

Inert gas filled contact chamber

Flying leads for coil connections

Load terminals threaded for M5 bolts (not included)

Performance Data

Physical Data

Contact Arrangement, Main

Contacts — SPST-NO-DM (1 Form X)

Dimensions — See drawings on next page

Weight — 6.7 oz (190g)

Contact Data

Contact Arrangement, Main

Contacts — SPST-NO-DM (1 Form X)

Voltage Rating, Main Contacts

Switching (Max) — 900VDC

Current Rating, Main Contacts

Switching —

Continuous 1 — 100A

Short Term, 3 Minutes² — 200A

Hot Switching Performance

(Polarity Sensitive) —

50A make/break @ +400Vdc — 50,000 cycles

100A make/break @ +400Vdc — 6,000 cycles

100A make/break @ -400Vdc — 1,000 cycles

200A make/break @ +400Vdc — 500 cycles

1,000A break only @ +400Vdc — 10 cycles

600A make only — 25 cycles

Maximum Short Circuit Current

(1/2 cycle, 60 Hz) — 1,250A

(through closed contacts)

Dielectric Withstand Voltage³ —

Between Open Contacts —

5,600Vrms/8,000Vdc

Contacts to Coil —

2,000Vrms/4,000Vdc

Insulation Resistance, Terminal to Terminal / Terminals to Coil —

When New — 100 megohms, min. @ 500Vdc

At End of Life — 50 megohms, min. @ 500Vdc

Mechanical Life — 1 million cycles

Operate & Release Time

Operate Time Max. — 25ms

Operate Bounce Max. — 5ms

Release Time — 10ms

Environmental Data

Shock, 11ms 1/2 sine

(operating) — 20G peak

Sine Vibration, 20G peak — 55-2,000 Hz.

Operating Temperature Range —

-55°C to +85°C

Noise Emission (at 100 mm

distance) — 70dB(a)

Notes

¹ 8.4 mm² conductor. Current rating depends upon conductor size. Keep terminals below 175°C max continuous.

² 3 minutes at +40°C ambient with 8.4 mm² (#8 AWG) conductor.

³ 2,000Vrms minimum under all conditions, until end of life.

For factory-direct application assistance, dial 800-253-4560, ext. 2055, or 805-220-2055.

KILOVAC CAP100 Series (Continued)

Coil Operating Voltage (Valid Over Temperature Range)			
Nominal Voltage	12Vdc	24Vdc	48Vdc
Pick Up Voltage (20°C)	8Vdc	16Vdc	33Vdc
Drop Out Voltage (20°C)	1.2Vdc	2.4Vdc	4.8Vdc
Coil Current (Nominal at 20°C, 12vdc)	461mA	250mA	122mA
Coil Power ¹ Nominal @ Vnom, +20°C	5.5W	6.0W	6.0W
Pickup (Close) Voltage Max. @85°C	9.6Vdc	19.2Vdc	38.4Vdc
Coil Resistance Nominal @ +20°C ± 5% (ohms)	26	96	392

¹ Do not exceed 8.0W coil power for extended periods

Life Cycles vs Resistive Load up to 900Vdc

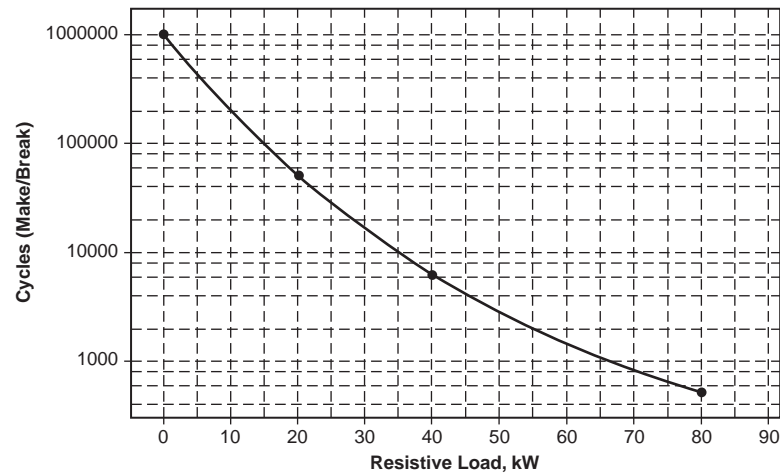

Ordering Information

Typical Part Number ► **CAP100 A 4 A N G**

Series: _____
CAP100 = 100A Contactor

Contact Arrangement: _____
A = 1 Form X (SPST-NO-DM)
K = NO with 1 SPDT Aux.

Coil Voltage: _____
4 = 12VDC
5 = 24VDC
6 = 48VDC

Coil Wire Length: _____
A = 15 inches [.4M]

Coil Termination: _____
N = None – Stripped Wires
(Consult factory for connector options)

Mounting and Power Terminals: _____
G = Bottom Mount (2 x #8); M5 x 10
H = Side Mount (2 x #8); M5 x 10

7
 KILOVAC High Voltage
 DC Contactors

For factory-direct application assistance,
dial 800-253-4560, ext. 2055, or
805-220-2055.

KILOVAC CAP100 Series (Continued)

Bottom Mount

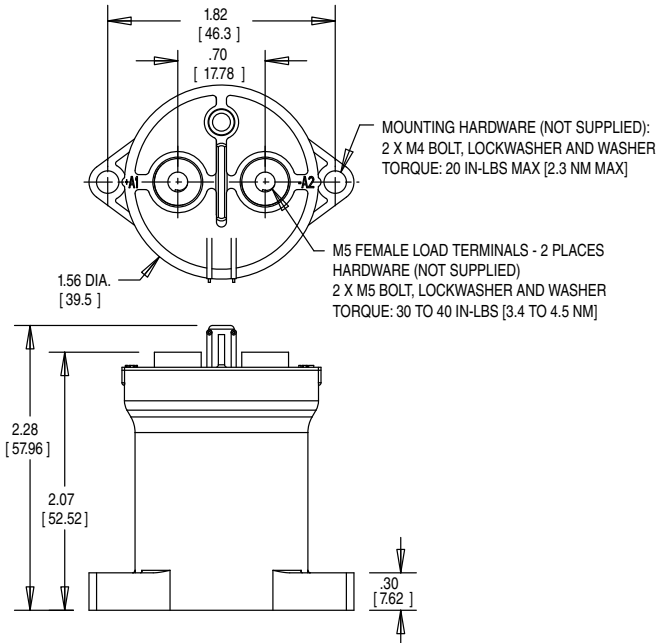

Side Mount

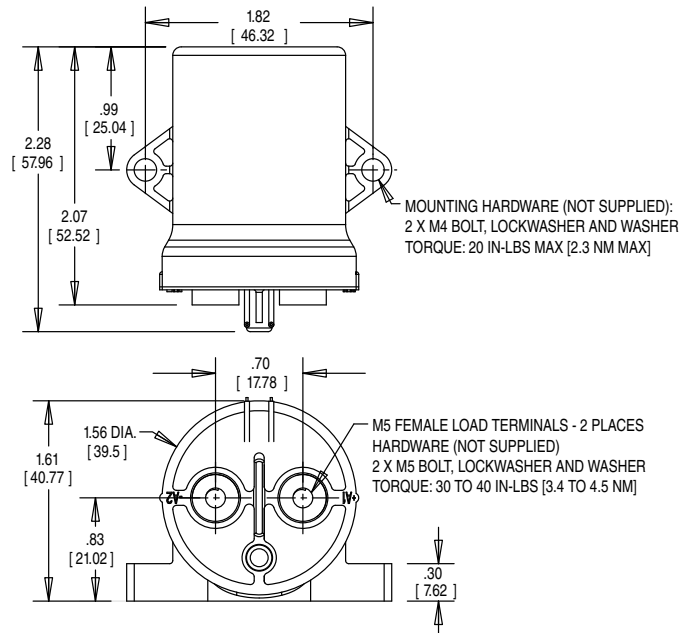

For factory-direct application assistance,
 dial 800-253-4560, ext. 2055, or
 805-220-2055.

KILOVAC EV200 Series Contactor With 1 Form X (SPST-NO) Contacts Rated 500+ Amps, 12-900 Vdc

Product Facts

- Designed to be the smallest, lightest weight, lowest cost sealed contactor in the industry with its current rating (500+A carry, 2000A interrupt at 320VDC)
- Built-in coil economizer — only 1.7W hold power @ 12VDC and it limits back EMF to 0V. Models requiring external economizer also available
- Optional auxiliary contact for easy monitoring of power contact position
- Hermetically sealed — intrinsically safe, operates in explosive/harsh environments with no oxidation or contamination of coil or contacts, during long periods of non-operation
- Versatile coil/power connections
- UL Recognized for the U.S. and Canada (File E208033) All contact ratings & coil versions may not be UL Recognized
- CE marked for EC applications
- AIAG QS9000 designed, built and approved
- RoHS versions available



EV200 Series Contactor (CZONKA Relay, Type III)

Coil Operating Voltage (Valid Over Temperature Range)			
Voltage (Will Operate)	9-36VDC	32-95VDC	48-95VDC
Voltage (Max.)	36VDC	95VDC	95VDC
Pickup (Close) Voltage Max.	9VDC	32VDC	48VDC
Hold Voltage (Min.)	7.5VDC	22VDC	34VDC
Dropout (Open) Voltage (Min.)	6VDC	18VDC	27VDC
Inrush Current (Max.)	3.8A	1.3A	0.7A
Holding Current (Avg.)	0.13A@12V, 0.07A@24V	0.03A@48V	0.02A@72V
Inrush Time (Max.)	130ms	130ms	130ms

Ordering Information

Typical Part Number ►

EV200 A A A N A

Series: _____
EV200 = 500+ Amp, 12-900VDC Contactor

Contact Form: _____
A = Normally Open
H = Normally Open with NO Aux. Contacts
G = Normally Open with NC Aux. Contacts

Coil Voltage: _____
A = 9-36VDC (1 = requires external coil economizer)
D = 32-95VDC (2 = requires external coil economizer)
J = 48-95VDC (3 = requires external coil economizer)
R = 28VDC with Mechanical Economizer

Coil Wire Length: _____
A = 15.3 in (390 mm)

Coil Terminal Connector: _____
N = None
C = Molex Mini-fit Jr, 2 Skt, Female 18-24,
P/N 39-01-2020 & 39-00-0060 +red is pin 1
(A length only)

Mounting & Power Terminals: _____
A = Bottom Mount & Male 10mm x M8 Terminals

Performance Data

Contact Arrangement, Power Contacts — 1 Form A (SPST-NO)

Rated Operating Voltage — 12 - 900 VDC

Continuous (Carry) Current, Typical — 500 A @ 85°C, 400 mcm conductors

Consult Factory for required conductors for higher (500+ A) currents

Make/Break Current at Various Voltages ¹ — See graph next page

Break Current at 320VDC ¹ — 2,000 A, 1 cycle ³

Contact Resistance, Typ. (@200A) — 0.2 mohms

Load Life — See graph next page

Mechanical Life — 1 million cycles

Contact Arrangement, Auxiliary Contacts — 1 Form A (SPST-NO)

Aux. Contact Current, Max. — 2A @ 30VDC / 3A @ 125VAC

Aux. Contact Current, Min. — 100mA @ 8V

Aux. Contact Resistance, Max. — 0.417 ohms @ 30VDC / .150 ohms @ 125VAC

Operate Time @ 25°C —

Close (includes bounce), Typ. — 15 ms
Bounce (after close only), Max. — 7 ms
Release (includes arcing), Max @ 2000A — 12 ms

Dielectric Withstanding Voltage — 2,200 Vrms @ sea level (leakage <1mA)

Insulation Resistance @ 500VDC — 100 megohms ²

Shock, 11ms 1/2 Sine, Peak, Operating — 20 G

Vibration, Sine, 80-2000Hz., Peak — 20 G

Operating Ambient Temperature — -40°C to +85°C

Weight, Nominal — .95 lb. (.43 kg)

Notes:

¹ Main power contacts

² 50 at end of life

³ Does not meet dielectric & IR after test, 1700 amp for unit with Aux. Contacts

For factory-direct application assistance, dial 800-253-4560, ext. 2055, or 805-220-2055.

KILOVAC EV200 Series (CZONKA Relay, Type III) (Continued)

Outline Dimensions

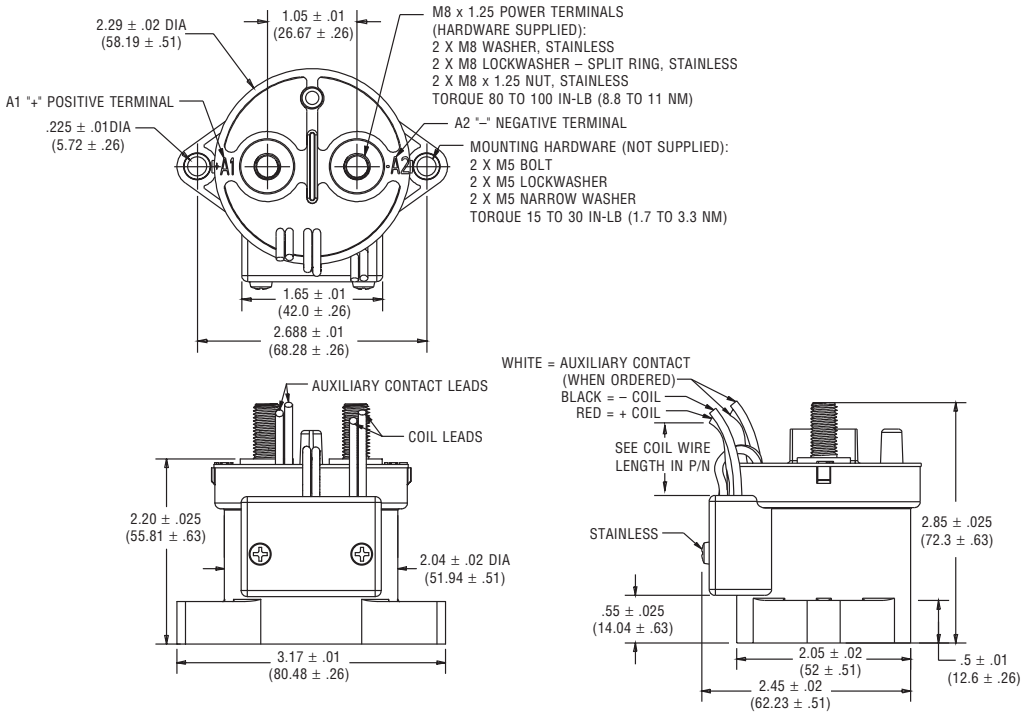

Estimated Make & Break Power Switching Ratings

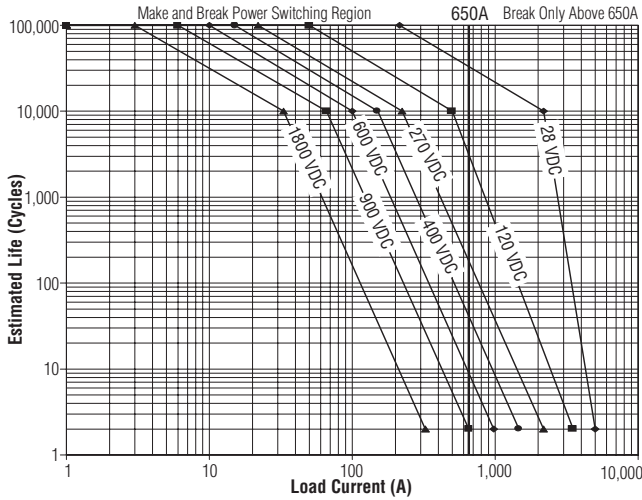

- NOTES:**
- 1) For resistive loads with 300µH maximum inductance. Consult factory for inductive loads.
 - 2) Estimates based on extrapolated data. User is encouraged to confirm performance in application.
 - 3) End of life when dielectric strength between terminals falls below 50 megohms @ 500VDC.
 - 4) The maximum make current is 650A to avoid contact welding.

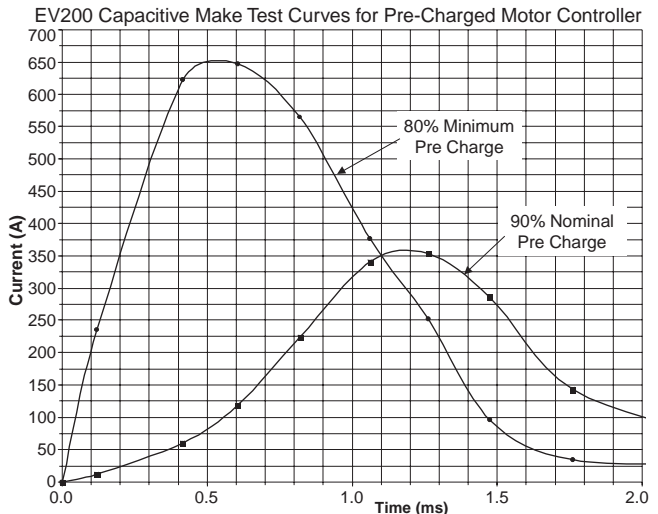

For factory-direct application assistance,
 dial 800-253-4560, ext. 2055, or
 805-220-2055.

KILOVAC EV200B Series Contactor With 1 Form Y (SPST-NC) Contacts Rated 500+ Amps, 12-900 Vdc

Product Facts

- Normally closed version of popular EV200 series contactors
- Designed to be the smallest, lowest cost, lightest weight sealed contactor in the industry at its current rating
- Optional auxiliary contacts for monitoring position of power contacts
- Hermetically sealed — operates in explosive/harsh environments with no oxidation or contamination of coil or contacts during long periods of non-operation
- Not position sensitive, can be mounted in any orientation
- RoHS versions available



Physical Data

Contact Arrangements — Main Contacts — SPST, Normally Closed
Dimensions — See drawing
Weight, Nominal — .95 lb. (.43 kg)

Environmental Data

Shock, 11ms 1/2 Sine (Operating) — 30 G_{peak} (Closed)
 10 G_{peak} (Open)
Sine Vibration, 10 G_{peak} — 55-2000 Hz
Random Vibration, 7.1 Grms — 15 Hz (.001 G^2/Hz), 100 Hz (.04 G^2/Hz), 1000 Hz (.04 G^2/Hz), 1500 Hz (.02 G^2/Hz)
Operating Temperature Range — -40°C to +85°C

Electrical Data

Voltage Rating — Main Contacts (Max) — 750 Vdc
Current Rating, Continuous — Main Contacts 1 — 500A
Contact Resistance — Main Contacts 2 — 0.2 m Ω max above 300A
 0.3 m Ω max between 50 and 300A
Hot Switching Performance (Positive Polarity) ³ — 200A make/ break @ 270Vdc — 10,000 cycles
 600A make/ break @ 360Vdc — 100 cycles
 800A break only @ 360Vdc — 15 cycles
 1500A break only @ 360Vdc — 1 cycle
Mechanical Life (Min) — 1 million cycles
Dielectric Withstand Voltage — Terminal to Terminal/ Terminals to Coil — 1mA max @ 2,200 Vrms

Dropout (Min) — 4/9 Vdc
Pickup Current, Peak ⁶ @ 25°C — 6 A
Operate Specs @ 25°C — Operate Time (Typ) — 15 ms
 Operate Bounce (Max) — 5 ms
 Release Time (Typ) — 15 ms
Economizer Operating Frequency — 18 kHz
Hold Current — 0.9A/12 Vdc
 0.3A/24 Vdc

Notes:

- ¹ Ambient conditions and conductor design affect rating. Terminal temperature rise should be 75°C max above ambient. Keep relay terminals below 150°C max continuous, 175°C max for two hours, and 200°C for 1 minute.
- ² Stabilized reading. Contact resistance may exceed spec in the first 10 minutes of current carry.
- ³ Units are polarity sensitive. Approximately 50% de-rating for reverse polarity switching. Consult factory for review of specific requirements.
- ⁴ Over temperature range unless noted.
- ⁵ Voltage ranged sensed by contactor 10 ms after application of source voltage.
- ⁶ Pickup duration 100 ms.

Insulation Resistance — Terminal to Terminal/ Terminals to Coil — 100M Ω min @ 500Vdc new
 50M Ω min @ 500Vdc end of life

Coil Data 4

Nominal Coil Voltage ⁵ — Low range — 9.6-14 Vdc
 High range — 19-28 Vdc
Pick Up (Max) @ 25°C — 9.6/18.5 Vdc
Pick Up @ Max Coil Temperature — 10.5/22 Vdc
Hold (Min) — 6/12 Vdc

Ordering Information

Typical Part Number ►

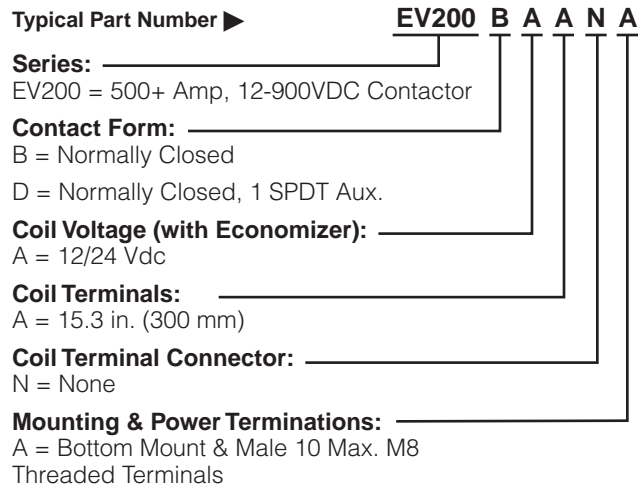

For factory-direct application assistance, dial 800-253-4560, ext. 2055, or 805-220-2055.

KILOVAC EV200B Series Contactor (Continued)

Outline Dimensions

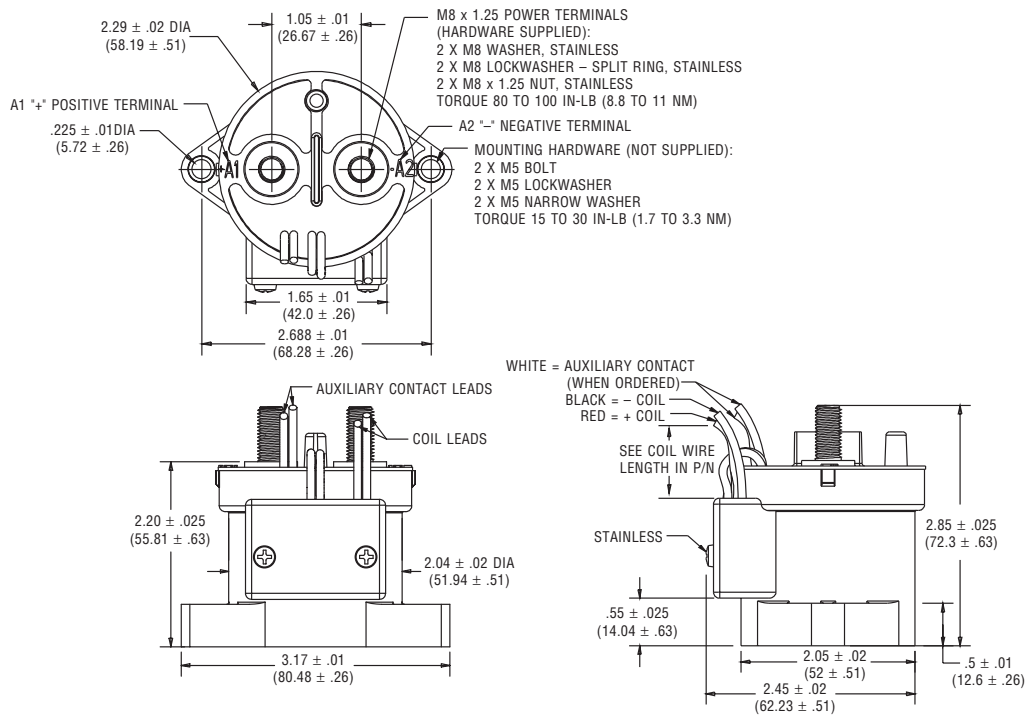

For factory-direct application assistance,
 dial 800-253-4560, ext. 2055, or
 805-220-2055.

KILOVAC EV200P Series Latching Contactor With 1 Form X (SPST Latch) Contacts Rated 500+ Amps, 12-900 Vdc

Product Facts

- Latching version of popular EV200 Series
- Designed to be the smallest, lowest cost, lightest weight sealed contactor in the industry at its current rating
- Optional auxiliary contacts for monitoring position of power contacts
- Hermetically sealed — operates in explosive/harsh environments with no oxidation or contamination of coil or contacts during long periods of non-operation
- Not position sensitive, can be mounted in any orientation
- RoHS versions available



Physical Data

Contact Arrangements — Main Contacts — SPST, Latching
Auxiliary Contacts 1 — Up to 2 Form A

Dimensions — See drawing

Weight, Nominal — .95 lb. (.43 kg)

Environmental Data

Shock, 11ms 1/2 Sine (Operating) — 30 G_{peak}

Sine Vibration, 20 G_{peak} — 55-2000 Hz

Random Vibration, 14.06 Grms — 15 Hz (.002 G²/Hz), 100 Hz (.002 G²/Hz), 450 Hz (.12 G²/Hz), 900 Hz (.12 G²/Hz), 2000 Hz (.083 G²/Hz)

Operating Temperature Range — -40°C to +85°C

Electrical Data

Voltage Rating — Main Contacts (Max) — 750 Vdc

Current Rating, Continuous — Main Contacts 2 — 500A

Contact Resistance — Main Contacts 3 — 0.2 mΩ max above 300A
0.3 mΩ max between 50 and 300A

Hot Switching Performance (Positive Polarity) 4 — 200A make/ break @ 270Vdc — 10,000 cycles
600A make/ break @ 360Vdc — 100 cycles
800A break only @ 360Vdc — 15 cycles
2000A break only @ 360Vdc — 1 cycle

Mechanical Life (Min) — 1 million cycles

Dielectric Withstand Voltage — Terminal to Terminal/ Terminals to Coil — 1mA max @ 2,200 Vrms

Insulation Resistance — Terminal to Terminal/ Terminals to Coil — 100MΩ min @ 500Vdc new
50MΩ min @ 500Vdc end of life

Coil Data 5

Nominal Coil Voltage 6 — 12 Vdc

Pick Up/Latch (Max) @ 25°C — 9 Vdc

Hold (Min) — N/A

Reset (Max)/Dropout (Min) — 9 Vdc

Duty Cycle, Max 7 — 20%

Coil Resistance @ 25°C — 2.5 Ω

Operate Specs @ 25°C —

Operate Time (Typ) — 15 ms

Operate Bounce (Max) — 7 ms

Release Time (Max) — 15 ms

Notes:

¹ Product can be configured alternately with form B or C auxiliary switches if required. This changes the product part number, depending on specific auxiliary configuration. Consult TE for availability and part number

² Ambient conditions and conductor design affect rating. Terminal temperature rise should be 75°C max above ambient. Keep relay terminals below 150°C max continuous, 175°C max for two hours, and 200°C for 1 minute.

³ Stabilized reading. Contact resistance may exceed spec in the first 10 minutes of current carry.

⁴ Units are polarity sensitive. Approximately 50% de-rating for reverse polarity switching. Consult factory for review of specific requirements.

⁵ Over temperature range unless noted. Suggested coil pulse = 50-100 ms.

⁶ 24V and 48V coils available on request — consult factory.

⁷ Intermittent Duty Coil. Coil overheating can occur if duty cycle is exceeded. Limit average coil power to 10W maximum.

Ordering Information

Typical Part Number ►

EV200 P 4 A N A

Series: EV200 = 500+ Amp, 12-900VDC Contactor

Contact Form: P = Latching
F = Latching with 1 SPDT Aux.

Coil Voltage: 4 = 12 Vdc
5 = 24 Vdc
6 = 48 Vdc

Coil Terminations: A = 15.3 in. (300 mm)

Coil Termination Connector: N = None

Mounting & Power Terminals: A = Bottom Mount & Male 10mm x M8 Threaded Terminals

For factory-direct application assistance, dial 800-253-4560, ext. 2055, or 805-220-2055.

KILOVAC EV200P Series Latching Contactor (Continued)

Outline Dimensions

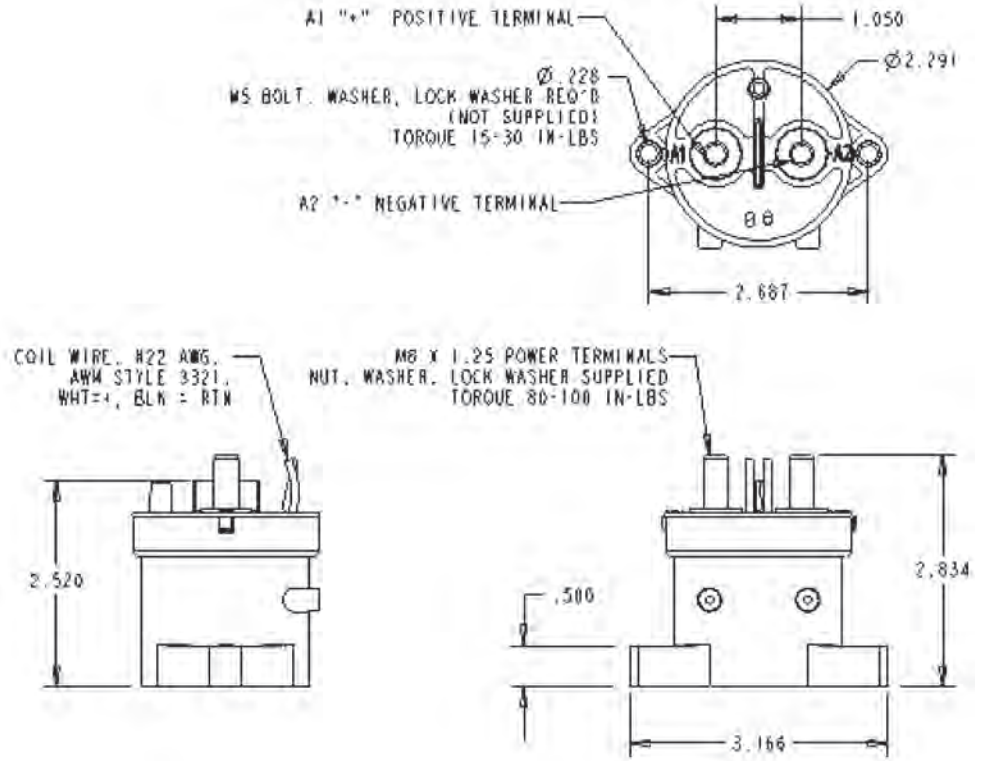

For factory-direct application assistance, dial 800-253-4560, ext. 2055, or 805-220-2055.

KILOVAC EV100 Series Contactor With 1 Form X Contacts Rated 100 Amps Continuous, 600 Vdc

Product Facts

- Hermetically sealed
- Operates in explosive/ harsh environments without oxidation or contamination of contacts, during long periods of non-operation
- 8kV isolation between open contacts permits use for high voltage isolation and carry
- Coil economizer allows for operation between 9-36 VDC
- Designed and built in accordance with AS 9100



Description

Low cost, 600 Vdc, 100 amp, hermetically sealed DC contactor

Economized coil for low power consumption between 9-36 VDC

Bottom mount, not position sensitive

One million cycle mechanical life

Applications

Power/motor control circuit isolation, circuit protection and safety in industrial machinery

Automotive battery switching and backup

Solar inverter switching

Automotive pre-charge

Test Equipment

Power distribution

Electrical

Contact arrangement: SPST-NO (Form X., Double Make)

Voltage rating:
5-600 Vdc at 100 Amps

50K cycles Make/Break:
50 Amps at 400 Vdc

25K cycles Make/Break:
50 Amps at 600 Vdc

Holding current:
0.15 Amps at 24 Vdc

Operate time: 30 ms max.

Physical or Other Properties

Hermetically sealed

Safe for harsh/corrosive environments

No contact oxidation over periods of non-use

Mechanical

Small size: 1.5" x 1.5" approximately

Weight: 130 grams

Performance Data

Physical Data

Contact Arrangement, Main Contacts — SPST-NO (Form X)

Dimensions — See drawings on next page

Weight — 4.58 oz (130g)

Electrical Data

Voltage Rating, Main Contacts Switching (Max) — 750VDC

Current Rating, Main Contacts Switching —

Continuous 1 — 100A
Short Term, 3 Minutes 2 — 200A

Contact Voltage Drop, Main

Contacts — 0.05 max @ rated current

Resistive Load Performance (polarity sensitive) —

50A make/break @ +400Vdc — 50,000 cycles

50A make/break @ +600Vdc — 25,000 cycles

100A make/break @ +400Vdc — 6,000 cycles

100A make/break @ +600Vdc — 5,000 cycles

100A make/break @ -400Vdc — 1,000 cycles

100A make/break @ -600Vdc — 25 cycles

200A make/break @ +400Vdc — 500 cycles

200A make/break @ +600Vdc — 200 cycles

1,000A break only @ +400Vdc — 5 cycles

600A break only @ +600Vdc — 5 cycles

600A make only — 10 cycles

Maximum Short Circuit Current (1/2 cycle, 60 Hz) — 1,250A
(through closed contacts)

Dielectric Withstand Voltage —
Between Open Contacts — 2,200Vrms
Contacts to Coil — 1,500Vrms/4,000Vdc

Insulation Resistance, Terminal to Terminal / Terminals to Coil —
When New — 100 megohms, min.
@ 500Vdc
At End of Life — 50 megohms, min.
@ 500Vdc

Mechanical Life — 106

Operate & Release Time

Operate Time Max. — 30ms

Operate Bounce Max. — 5ms

Release Time — 10ms

Environmental Data

Shock, 11ms 1/2 sine (operating) — 20G peak

Sine Vibration, 20G peak — 55-2,000 Hz.

Operating Temperature Range — -40°C to +85°C

Noise Emission (at 100 mm distance) — 70dB(a)

Notes

¹ 8.4mm² conductor. Current rating is affected by conductor size. Keep terminals below 150°C max. continuous.

² 3 minutes at +40°C ambient, 1 minute at -80°C ambient with 8.4mm² (#8 AWG) conductor.

For factory-direct application assistance, dial 800-253-4560, ext. 2055, or 805-220-2055.

KILOVAC EV100 Series (Continued)

Outline Dimensions

Bottom Mount

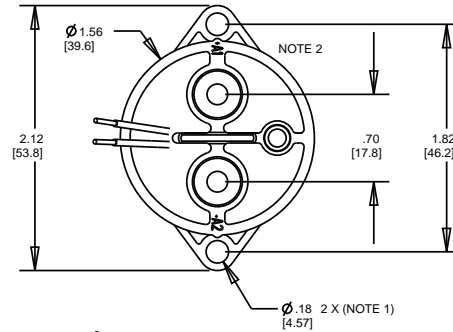

NOTE 1. MOUNTING HARDWARE (NOT SUPPLIED)
2 X M4 BOLT, LOCKWASHER AND WASHER
TORQUE: 20 IN-LBS (2.3 NM) MAX

NOTE 2. LOAD TERMINALS-2 PLCS
HARDWARE NOT SUPPLIED
2 X M5 BOLT, LOCKWASHER AND WASHER
TORQUE: 30-40 IN-LBS (3.4 TO 4.5 NM)
DEPTH: 7 THREADS MAX

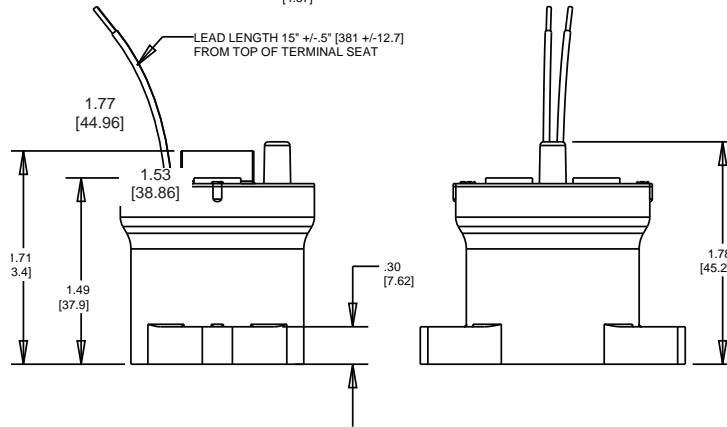

Coil Data (Internal Coil Economizer)	
Coil Voltage Range	9-32 Vdc
Maximum Pickup Current (20°C)	1.5A
Average Holding Current (20°C)	0.25A@12Vdc/0.15A@24Vdc
Pickup Voltage (20C)	≥ 9Vdc
Dropout Voltage	≤ 8Vdc
Pickup Pulse (max.)	100 ms
Coil Resistance +/-5% (20°C)	8.0 Ω
Coil Economizer Frequency	19.6 kHz
Coil Power Typ. (over temp range)	3-4W

Ordering Information

Typical Part Number ▶

EV100 A A A N A

Series: EV100 = 100A, 600 Vdc Contactor

Contact Form: A = Normally Open

Coil Voltage: 9-36 Vdc

Coil Wire Length: A = 15 inches [.4M]

Coil Termination: N = None – Stripped Wires

Mounting: A = Bottom Mount 2X #8, M5X10 Mains

Specifications are subject to change without notice.

For factory-direct application assistance,
dial 800-253-4560, ext. 2055, or
805-220-2055.

KILOVAC LEV100 Series 900 Vdc Contactor With 1 Form X Contacts Rated 100A Continuous

Product Facts

- Hermetically sealed — intrinsically safe. Operates in explosive/harsh environments without oxidation or contamination of contacts, including long periods of non-operation
- 8kV isolation between open contacts permits use for high voltage isolation and carry
- 12, 24 and 48 Vdc coils
- Designed and built in accordance to AIAG QS9000
- Not position sensitive, can be mounted in any orientation
- Solid copper contacts
- UL Recognized for the U.S. and Canada (File E208033) All contact ratings & coil versions may not be UL Recognized
- RoHS versions available



Description

Lowest cost, 900 Vdc 100 amp, hermetically sealed DC contactor in the industry

Compact package available in side- or bottom-mount configurations, not position sensitive

Applications

Power/motor control circuit isolation, circuit protection and safety in industrial machinery

Automotive battery switching and backup

Mechanical

Compact epoxy-sealed resin enclosure occupies only about 4 in³ (65.5 cm³)

Robust integral mounting plate on either bottom or side of enclosure accepts two M4 screws

Inert gas filled contact chamber

Flying leads for coil connections

Load terminals threaded for M5 bolts (not included)

Performance Data

Physical Data

Contact Arrangement, Main Contacts — SPST-NO-DM (1 Form X)

Dimensions — See drawings on next page

Weight — 6.7 oz (190g)

Contact Data

Contact Arrangement, Main Contacts — SPST-NO-DM (1 Form X)

Voltage Rating, Main Contacts Switching (Max) — 900VDC

Current Rating, Main Contacts Switching —

Continuous¹ — 100A
Short Term, 3 Minutes² — 200A

Hot Switching Performance (Polarity Sensitive) —

50A make/break @ +400Vdc — 50,000 cycles

100A make/break @ +400Vdc — 6,000 cycles

100A make/break @ -400Vdc — 1,000 cycles

200A make/break @ +400Vdc — 500 cycles

1,000A break only @ +400Vdc — 250 cycles

600A make only — 25 cycles

Maximum Short Circuit Current (1/2 cycle, 60 Hz) — 1,250A (through closed contacts)

Dielectric Withstand Voltage³ —

Between Open Contacts —

5,600Vrms/8,000Vdc

Contacts to Coil —

2,000Vrms/4,000Vdc

Insulation Resistance, Terminal to Terminal / Terminals to Coil —

When New — 100 megohms, min. @ 500Vdc

At End of Life — 50 megohms, min. @ 500Vdc

Mechanical Life — 1 million cycles

Operate & Release Time

Operate Time Max. — 25ms

Operate Bounce Max. — 5ms

Release Time — 10ms

Environmental Data

Shock, 11ms 1/2 sine (operating) — 20G peak

Sine Vibration, 20G peak — 55-2,000 Hz.

Operating Temperature Range — -40°C to +85°C

Noise Emission (at 100 mm distance) — 70dB(a)

Notes

¹ 8.4 mm² conductor. Current rating depends upon conductor size. Keep terminals below 175°C max continuous.

² 3 minutes at +40°C ambient with 8.4 mm² (#8 AWG) conductor.

³ 2,000Vrms minimum under all conditions, until end of life.

For factory-direct application assistance, dial 800-253-4560, ext. 2055, or 805-220-2055.

KILOVAC LEV100 Series 900 Vdc Contactor (Continued)

Coil Operating Voltage (Valid Over Temperature Range)			
Nominal Voltage	12Vdc	24Vdc	48Vdc
Maximum Voltage	16Vdc	28Vdc	52Vdc
Pick Up Voltage (20°C)	8Vdc	16Vdc	33Vdc
Drop Out Voltage (20°C)	≤1.2Vdc	≤2.4Vdc	≤4.8Vdc
Coil Current (Nominal at 20°C, 12vdc)	461mA	250mA	122mA
Coil Power Nominal @ Vnom, +20°C	5.5W	6.0W	6.0W
Pickup (Close) Voltage Max. @85°C	9.6Vdc	19.2Vdc	38.4Vdc
Coil Resistance Nominal @ +20°C ± 5% (ohms)	26	96	392

Life Cycles vs Resistive Load up to 900Vdc

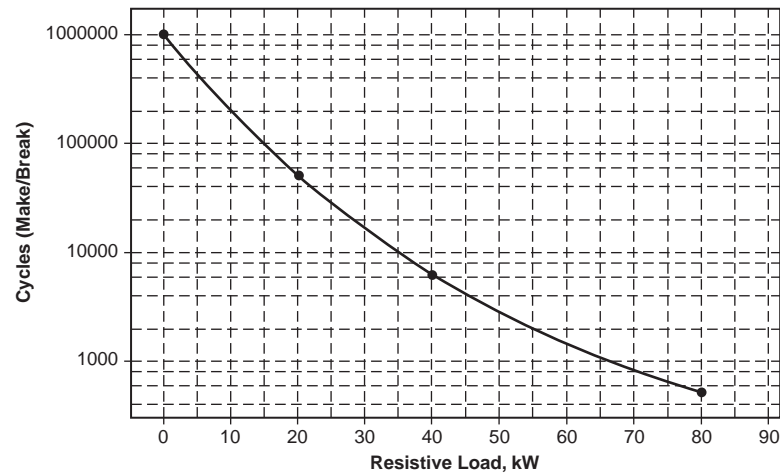

Ordering Information

Typical Part Number ▶ **LEV100 A 4 A N G**

Series: _____
LEV100 = 100A Contactor

Contact Arrangement: _____
A = 1 Form X (SPST-NO-DM)

Coil Voltage: _____
4 = 12VDC
5 = 24VDC
6 = 48VDC

Coil Wire Length: _____
A = 15 inches [.4M]

Coil Termination: _____
N = None – Stripped Wires

Mounting and Power Terminals: _____
G = Bottom Mount (2 x #8); M5 x 10
H = Side Mount (2 x #8); M5 x 10

For factory-direct application assistance, dial 800-253-4560, ext. 2055, or 805-220-2055.

KILOVAC LEV100 Series 900 Vdc Contactor (Continued)

Bottom Mount

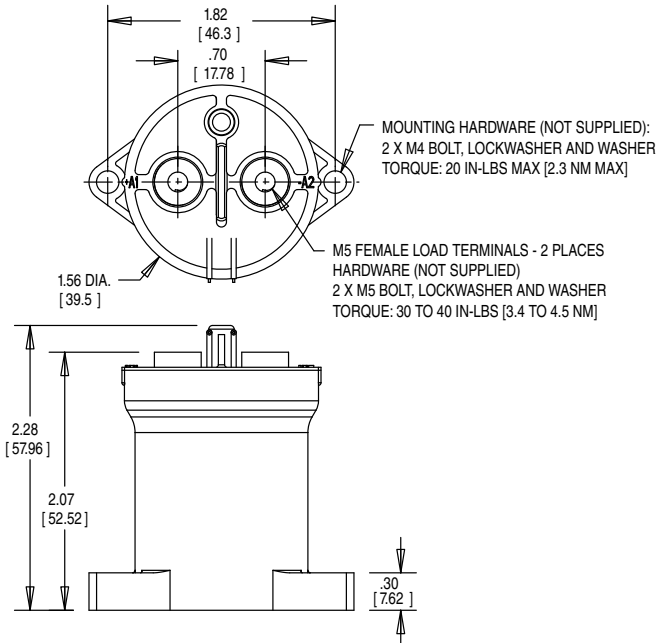

Side Mount

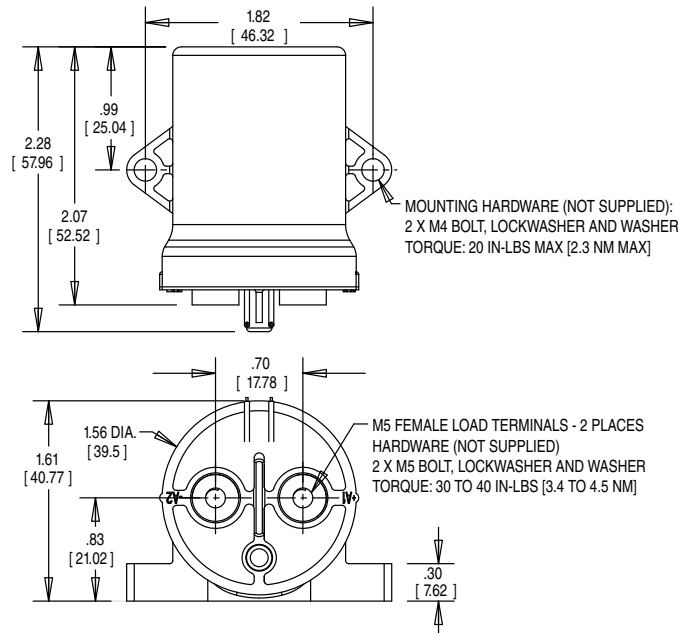

Product Offering

Bottom Mount Models			
3-1618389-7	LEV100A4ANG	12Vdc coil	15" [.4m] leads
9-1618389-8	LEV100A5ANG	24Vdc coil	15" [.4m] leads
3-1618391-7	LEV100A6ANG	48Vdc coil	15" [.4m] leads
Side Mount Models			
4-1618391-0	LEV100A4ANH	12Vdc coil	15" [.4m] leads
4-1618391-1	LEV100A5ANH	24Vdc coil	15" [.4m] leads
4-1618391-2	LEV100A6ANH	48Vdc coil	15" [.4m] leads

For factory-direct application assistance, dial 800-253-4560, ext. 2055, or 805-220-2055.

KILOVAC LEV200 Series Contactor With 1 Form X Contacts Rated 500+ Amps, 12-900Vdc

Product Facts

- Designed to be the lowest cost sealed contactor in the industry with its current rating (500+A carry, 2000A interrupt at 320Vdc)
- Available with bottom or side mounting — not position sensitive
- Optional auxiliary contact for easy monitoring of power contact position
- Hermetically sealed — intrinsically safe, operates in explosive/harsh environments with no oxidation or contamination of coils or contacts, including long periods of non-operation
- Typical applications include battery switching and backup, DC voltage power control, circuit protection and safety
- Versatile coil/power connections
- Designed and built in accordance to AIAG QS9000
- RoHS compliant



Coil Data (Valid Over Temperature Range) ⁴

Nominal Voltage	12Vdc	24Vdc	48Vdc	72Vdc
Pickup Voltage (Will Operate)	9.0Vdc	19.0Vdc	38.0Vdc	57.0Vdc
Voltage (Max.)	15Vdc	30Vdc	60Vdc	90Vdc
Dropout Voltage	0.75 - 2.0Vdc	1.0 - 5.0Vdc	2.0 - 7.0Vdc	3.0 - 12.0Vdc
Coil Resistance @ 25° (Typ.)	11 ohms	40 ohms	145 ohms	357 ohms

Ordering Information

Typical Part Number ►

LEV200 A 4 N A A

Series:

LEV200 = 500+ Amp, 12-900Vdc Contactor

Contact Form:

A = Normally Open

H = Normally Open with Aux. Contacts. (Option "H" requires option "A" in Coil Wire Length and option "N" in Coil Terminal Connector.)

Note: Other auxiliary contact forms available. Consult factory.

Coil Voltage:

4 = 12Vdc 5 = 24Vdc B = 28Vdc

6 = 48Vdc K = 72Vdc

8 = 96Vdc L = 110Vdc O = 115Vac 9 = 240Vac

Notes: Consult factory for detailed specifications and availability of coils not listed in "Coil Data" table above. In coil voltage codes, 115Vac is designated by the letter "O" rather than the numeral "0."

Coil Wire Length:

A = 15.3 in (390 mm) N = None (Requires option "A" in next step.)

Coil Terminal Connector:

N = None, stripped wires

(Requires option "A" in previous step.)

A = Studs, #10-32 Threaded (Electrical connection is made to the tab at the base of the stud.)

Note: Specify option A, stripped wires, for coil voltages > 96Vdc

Mounting & Power Terminals:

A = Bottom Mount & Male 10mm x M8 Threaded Terminals

F = Side Mount & Male 10mm x M8 Threaded Terminals

Consult factory regarding other available mountings and power terminals.

Performance Data

Contact Arrangement, Power Contacts

— 1 Form X (SPST-NO-DM)

Rated Operating Voltage

— 12 - 900 VDC

Continuous (Carry) Current, Typical

— 500 A @ 65°C, 400 mcm conductors

Consult TE for required conductors for higher (500+ A) currents

Make/Break Current at Various Voltages ¹

— See graph next page

Break Current at 320VDC ¹

— 2,000 A, 1 cycle ³

Contact Resistance, Typ. (@200A)

— 0.2 mohms

Load Life

— See graph next page

Mechanical Life

— 1 million cycles

Contact Arrangement, Auxiliary Contacts

— 1 Form A (SPST-NO)

Aux. Contact Current, Max.

— 2A @ 30VDC / 3A @ 125VAC

Aux. Contact Current, Min.

— 100mA @ 8V

Aux. Contact Resistance, Max.

— 0.417 ohms @ 30VDC /

.150 ohms @ 125VAC

Operate Time @ 25°C

Close (includes bounce), Typ. — 25 ms

Bounce (after close only), Max. — 7 ms

Release (includes arcing), Max @

2000A — 12 ms

Dielectric Withstanding Voltage

— 2,200 Vrms @ sea level (leakage <1mA)

Insulation Resistance @ 500VDC

— 100 megohms ²

Shock, 11ms 1/2 Sine, Peak, Operating

— 20 G

Vibration, Sine, 80-2000Hz., Peak

— 20 G

Operating Ambient Temperature

— -40°C to +85°C

Weight, Typical

— 1.3 lb. (.60 kg)

Notes:

¹ Main power contacts

² 50 at end of life

³ Does not meet dielectric & IR after test, 1700 amp for unit with Aux. Contacts

⁴ Contacts will operate with 0.8V_{nom} < V_{coil} < 1.1V_{nom} over temperature range.

Invalid Combinations/Reason

LEV200H-NA_ No auxiliary function with coil studs

LEV200_ONA_

No coil studs with rectifier circuit

LEV200_9NA_

No coil studs with rectifier circuit

LEV200_O_F

No side mount with rectifier circuit

LEV200_9_F

No side mount with rectifier circuit

For factory-direct application assistance, dial 800-253-4560, ext. 2055, or 805-220-2055.

KILOVAC LEV200 Series (Continued)

Outline Dimensions

Side Mount Enclosure

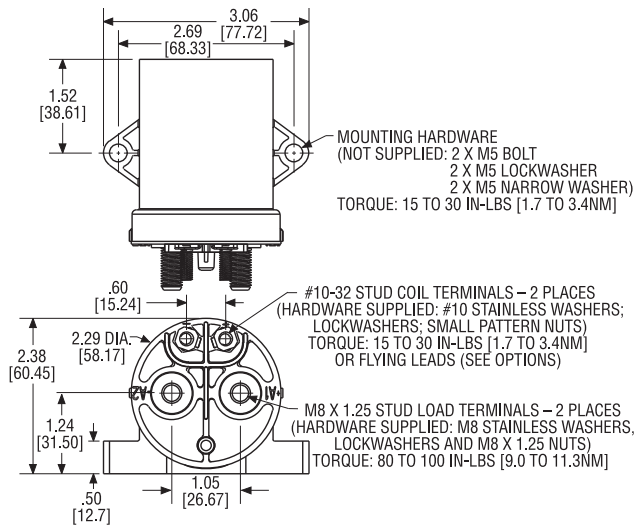

Note: When stud terminals are specified for coil connections, the electrical connection is made at the tab located at the base of the stud.

Bottom Mount Enclosure

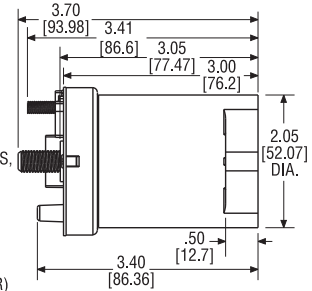
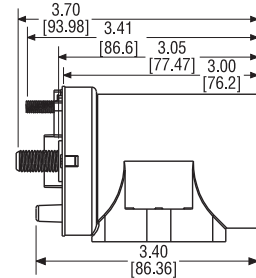
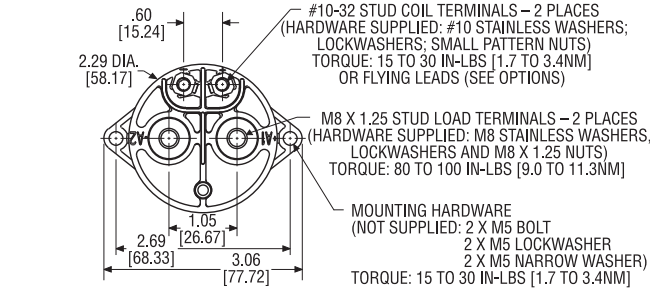

Estimated Make & Break Power Switching Ratings

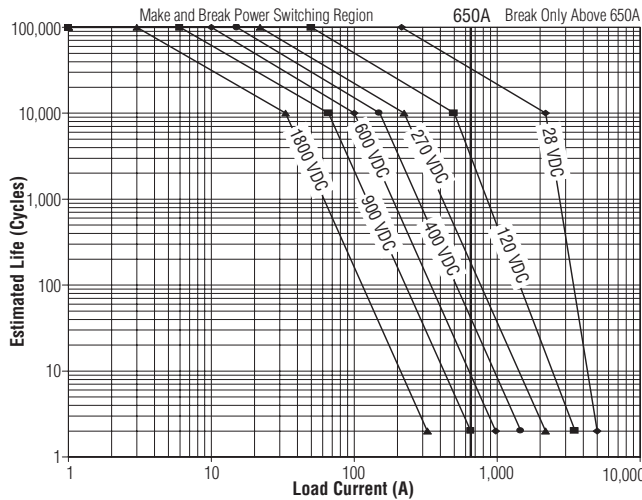

- NOTES:**
- 1) For resistive loads with 300µH maximum inductance. Consult factory for inductive loads.
 - 2) Estimates based on extrapolated data. User is encouraged to confirm performance in application.
 - 3) End of life when dielectric strength between terminals falls below 50 megohms @ 500VDC.
 - 4) The maximum make current is 650A to avoid contact welding.

LEV200 Capacitive Make Test Curves for Pre-Charged Motor Controller

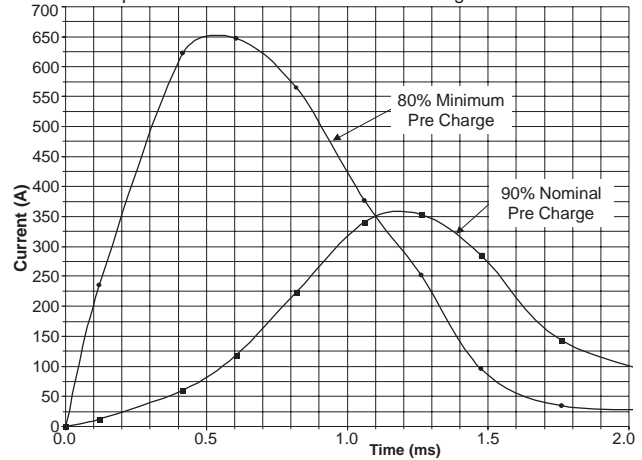

For factory-direct application assistance, dial 800-253-4560, ext. 2055, or 805-220-2055.

FM200 (“Flatman III”) Series Contactor 200 Amps, 480 VAC (50/60 Hz), or 48 Vdc, 1-, 2-, or 3-poles

Product Facts

- Multi-pole configurations
- Normally open, normally closed and mixed contact arrangements
- Optional quick connect tabs for sensing
- Small, lightweight & cost-effective – designed to be the smallest, lowest cost contactor in the industry with its current rating
- Standard models available with 12VDC, 24VDC and 115 VAC coils. Consult factory for 240VAC coil models.
- 1 Form A auxiliary contacts



File E208033

For factory-direct application assistance, dial 800-253-4560, ext. 2055, or 805-220-2055.

Product Specifications

Parameter	Units	Value for FM200 Series
Contact Arrangement		1, 2 or 3 poles
Contact Form (per pole)		Form X or Y (NO-DM or NC-DB)
Rated Operating Voltage	V	480Vrms (L-L) or 48VDC
Max. Contact Voltage (transient)	V	750Vrms or 60VDC
Continuous (Carry) Current	Arms or ADC	200/pole (Form X) 150/pole (Form Y)
Power Switching Form X (0.7-1.0 PF)	Cycles	2,000 @ 300Arms 10,000 @ 200Arms 20,000 @ 100Arms 5,000 @ 200A/48VDC 2 million @ 50A/28VDC
Power Switching Form Y (0.7-1.0 PF)	Cycles	2,000 @ 225Arms 10,000 @ 150Arms 20,000 @ 75Arms 5,000 @ 150A/48VDC 2 million @ 35A/28VDC
Mechanical Life	Cycles	>2 million
Contact Voltage Drop	mV	75 for Form X or Form Y
Auxiliary Contact Arrangement		1 Form A (SPST-NO)
Auxiliary Contact Rating	Arms or ADC	1 @ 30VDC, 3 @ 125VAC
Dielectric Withstanding Voltage	Vrms	2,200 @ sea level
Insulation Resistance @ 500VDC	Megohms	100
Shock, 11ms 1/2 sine, peak	G	10
Vibration, sine, 10-2000Hz.	G	5
Operating Temperature	°C	-20 to +60
Storage Temperature	°C	-40 to +85
Ambient Humidity	%RH	0 to 95
Weight	oz. / kg	17.6 - 49.4 / 0.5 - 1.4
See Outline Dimensions for model-specific weight information.		

Available Pole Configurations and Applicable Coil Codes

No. of NC Poles (across)	0	1	2	3
No. of NO Poles (down)	0	Y	YY	YYY
		Coil D	Coil D	Coil D
1	X	XY	YXY	
	Coil A/B/C/E	Coil A/B/C/E	Coil D	
2	XX	XYX		
	Coil A/B/C/E	Coil A/B/C/E		
3	XXX			
	Coil A/B/C/E			

X = Form X (NO-DM) Y = Form Y (NC-DB)

Coil Operating Voltage (valid over temperature range)

Coil Designator	Units	A	B	C	D
Nominal Voltage	V	12 (DC)	24 (DC)	115 (AC)	24 (DC)
Voltage Range	V	9.6-13.2	19.2-26.4	92-126.5	19.2-26.4
Hold Voltage	V	≥0.5V _{nom}	≥0.5V _{nom}	≥0.5V _{nom}	≥0.5V _{nom}
Dropout Voltage	V	≤0.1V _{nom}	≤0.1V _{nom}	≤0.1V _{nom}	≤0.2V _{nom}

Coil Resistance Data for Pole Configurations (@25°C)

Coil Designator	Units	A	B*	C*	D*
Resistance ±10%	Ohms	X = 36 XX = 18 XXX = 12 XY = 13.2 YXY = 9.6	X = 36 XX = 18 XXX = 12 XY = 13.2 YXY = 9.6	X = 36 XX = 18 XXX = 12 XY = 13.2 YXY = 9.6	Y = 20.8 YY = 10.4 YYY = 6.9 YXY = 8.1

*Coil resistance not measurable at terminals due to converter/economizer circuit.

Coil Current/Power Data for Pole Configurations (@25°C, V_{coil}=1.1V_{nom})

Coil Designator	A	B**	
Current/Power	X = 0.37 ADC / 4.84W XX = 0.73ADC / 9.68W XXX = 1.1ADC / 14.5W XY = 1.0ADC / 13.2W YXY = 1.38ADC / 18.2W	X = 0.33ADC / 3.9W XX = 0.65ADC / 7.6W XXX = 0.97ADC / 11.3W XY = 0.98ADC / 12.7W YXY = 1.31ADC / 16.5W	
Coil Designator	C	D***	Pick-Up I / Duration
Current/Power	X = 0.067 Arms / 6.8VA XX = 0.115Arms / 11.6VA XXX = 0.146Arms / 14.8VA XY = 0.074Arms / 7.5VA YXY = 0.161Arms / 16.3VA	Y = 0.13ADC / 3.4W YY = 0.23ADC / 6.1W YXY = 0.34ADC / 9.0W	1.28ADC / 75ms 2.4ADC / 75ms 3.0ADC / 75ms 3.0ADC / 75ms

**Average coil current.

***Economized.

Operate/Release Time (25°C, 0.8V_{nom} ≤ V < V_{nom}) Typ.

Coil Designator	Units	A	B****	C****	D****
Operate Time	ms	25-50	30-50	50-150	20-30
Release Time	ms	10-20	70-80	75-100	75-100
Bounce Time	ms	2-5	2-5	2-5	2-5

****Includes internal coil suppression.

FM200 “Flatman III” Series Contactor (Continued)

Part Numbering System

Typical Part Number	FM200	A	B	XYX
<p>Series: FM200 = Multipole, 200 Amp, 480VAC/48VDC Contactor</p> <p>Control Voltage: A = 12VDC Coil, No Suppression B = 24VDC Converter, with Suppression C = 115VAC Converter, with Suppression D = 24VDC Electronic Chopper, with Suppression E = 240VAC Converter, with Suppression - Consult Factory for Availability and Specifications</p> <p>Optional Termination: A = Optional Quick Connect Tabs B = No Optional Terminals</p> <p>Pole Configuration (All models have a 1 Form A (SPST-NO) auxiliary switch): X = 1 Form X (SPST-NO-DM), Available with control voltage codes A, B, C and E XX = 2 Form X (2PST-NO-DM), Available with control voltage codes A, B, C and E XXX = 3 Form X (3PST-NO-DM), Available with control voltage codes A, B, C and E Y = 1 Form Y (SPST-NC-DB), Available only with control voltage code D YY = 2 Form Y (DPST-NC-DB), Available only with control voltage code D YYY = 3 Form Y (3PST-NC-DB), Available only with control voltage code D XY = 1 Form X (SPST-NO-DM) + 1 Form Y (SPST-NC-DB), Available with control voltage codes A, B, C and E XYX = 1 Form X (SPST-NO-DM) + 1 Form Y (SPST-NC-DB) + 1 Form X (SPST-NO-DM), Available with control voltage codes A, B, C and E YXY = 1 Form Y (SPST-NC-DB) + 1 Form X (SPST-NO-DM) + 1 Form Y (SPST-NC-DB), Available only with control voltage code D</p>				

Outline Dimensions

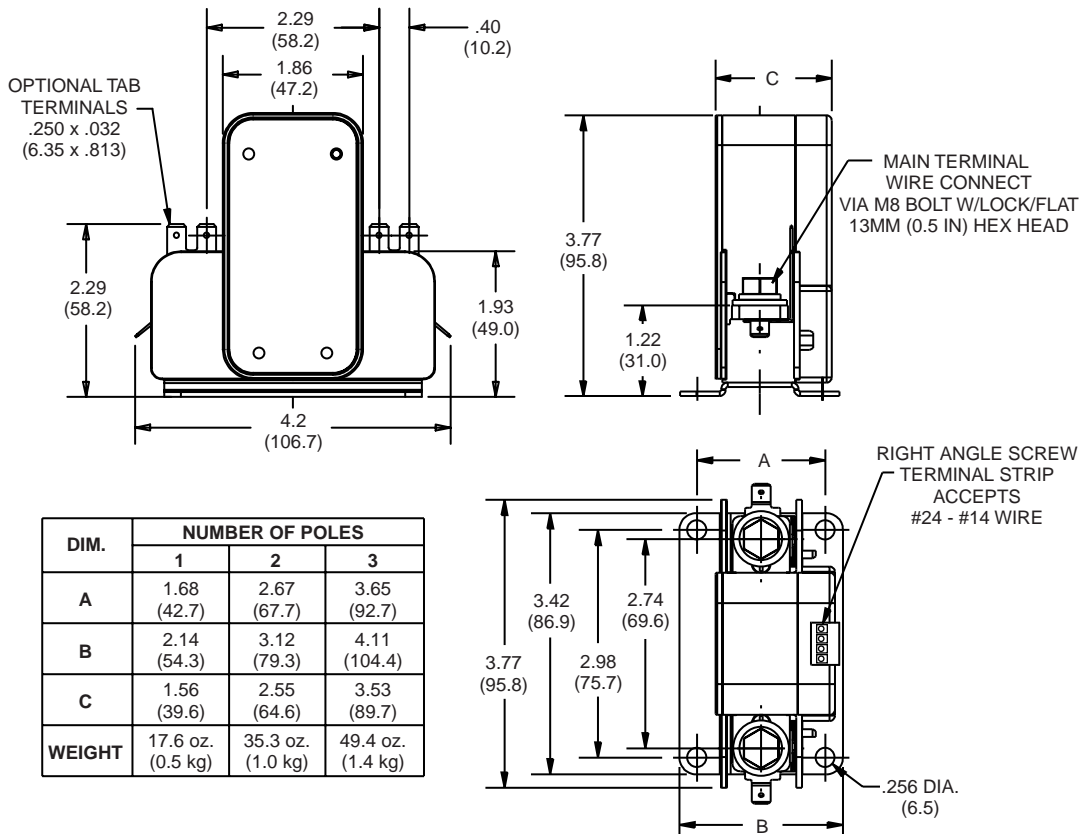

For factory-direct application assistance, dial 800-253-4560, ext. 2055, or 805-220-2055.

AC30 Series Contactor, 60 Amps, 600 VAC (50/60 Hz), 3 Form A (3PST-NO)

Product Facts

- Designed to be the smallest, lowest cost contactor in the industry with its current rating
- Built-in coil economizer – only 1.7W hold power @ 12VDC and limits back EMF to zero volts
- Hermetically sealed – intrinsically safe, operates in explosive & harsh environments with no oxidation or contamination of coils or contacts, including long periods of non-operation.



Submitted for UL and CE evaluation

For factory-direct application assistance, dial 800-253-4560, ext. 2055, or 805-220-2055.

Performance Data

Parameter	Units	Value for AC30 Series
Contact Arrangement		3 poles
Contact Form (per pole)		Form A (NO)
Rated Operating Voltage	V	600Vrms (L-L)
Max. Contact Voltage (transient)	V	600Vrms (L-N)
Continuous (Carry) Current	Arms	60/pole
Power Switching (0.7-1.0 PF)	Cycles	50 @ 60Arms 500 @ 10Arms 500 @ 30Arms 10,000 @ 10Arms 50,000 @ 5Arms
Mechanical Life	Cycles	1 million
Contact Voltage Drop (Max., Per Pole)	mV	120 @ 60Arms
Dielectric Withstanding Voltage	Vrms	2,200 @ sea level
Insulation Resistance @ 500VDC	Megohms	100
Shock, 11ms 1/2 sine, peak, operating	G	20
Vibration, sine, 80-2000Hz.	G	20
Operating Temperature	°C	-40 to +85
Storage Temperature	°C	-55 to +125
Ambient Humidity	%RH	0 to 95
Weight	lb.(kg)	.83 (.38)

Operate/Release Time (25°C)

Operate Time (Includes bounce)	ms	16 nominal / 35 maximum
Bounce Time (After Operate)	ms	4 nominal / 11 maximum
Release Time (includes arcing)	ms	5 nominal / 8 maximum

Coil Operating Voltage (valid over temperature range)

Voltage (will operate)	9-36VDC	32-95VDC	48-95VDC
Voltage (Max.)	36VDC	95VDC	95VDC
Pickup (close) Voltage Max.	9VDC	32VDC	48VDC
Hold Voltage (Min.)	7VDC	21VDC	33VDC
Dropout (open) Voltage (Min.)	6VDC	18VDC	27VDC
Inrush Current (Max.)	3.8A	1.3A	0.7A
Holding Current (Avg.)	0.13A@12V, 0.07A@24V	0.03A@48V	0.02A@72V
Inrush Time (Max.)	130ms	130ms	130ms

Part Numbering System

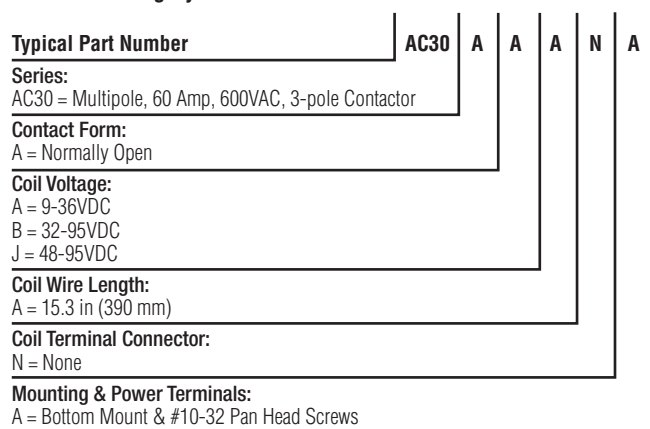

Outline Dimensions

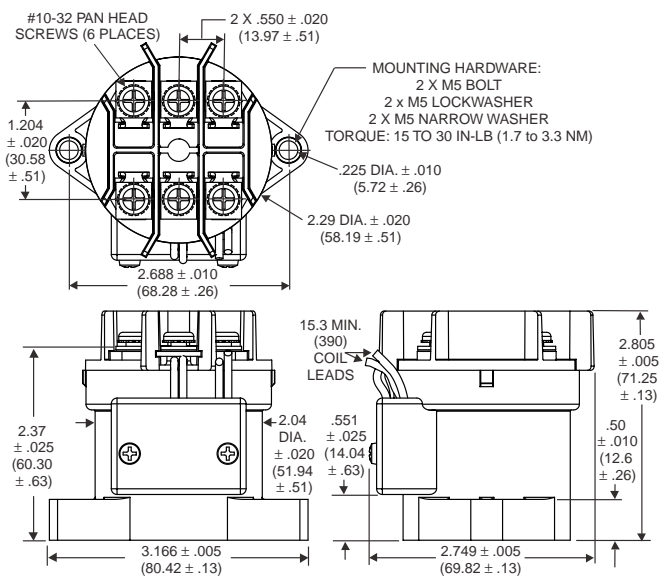

AP90X-05 - 90 Amps SPUD Contactor

Product Facts

- 90 A carry, 350 A overload @ 270 Vdc
- Same size and weight as AP50X
- Versatile power, voltage, and current operating range
- Ideal for circuit protection and control
- Bi-directional switching
- Fast operate and release time
- Low power consumption
- Vacuum-sealed contacts; can operate in harsh environments
- Space-rated version built in accordance with customers SCD
- Meets many requirements of MIL-PRF-32085

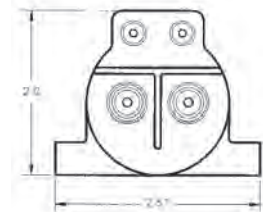
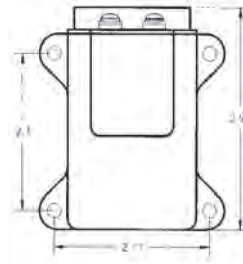

Contact Ratings*

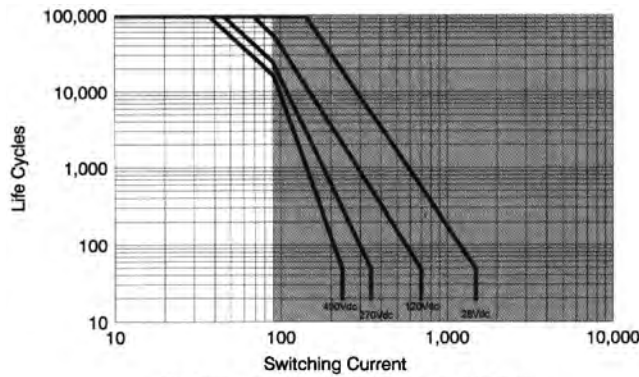

*Based on data extrapolated from qualification at 270 Vdc with resistive load. Since each application is unique, user is encouraged to verify rating in actual application.

Product Specifications

Contact Arrangement — SPST-NO
Contact Form — X
Rated Resistive Load @ 270 Vdc — 90 A
Continuous Current Carry, Max. — 65 A
Overload @ 270 Vdc — 350 A
Contact Resistance, Max. — 2 mohm

Dielectric at Sea Level — Coil to Power Terminals — 1,800 Vrms
 All Other Points — 2,000 Vrms
Shock, 11ms, 1/2 Sine (Peak) — 30 g
Vibration, Sinusoidal (55-2000 Hz, Peak) — 20 g
Operating Ambient Temperature Range — -55°C to +90°C
Load Life @ 270 Vdc, Min. — 25,000 cycles

Operate Time, Excluding Bounce, Max. — 35 ms
Release Time, Max. — 10 ms
Bounce Time, Max. — 8 ms
Insulation Resistance @ 500 Vdc, Min. — Initial — 100 mohm
 End of Life — 50 mohm
Weight, Nominal — 454 gram (16 oz.)

Coil Data

Volts, Nominal	12	28	120
Pickup, Max.	9.9 Vdc	23 Vdc	99 Vdc
Dropout, Min.	.4 Vdc	1.0 Vdc	4.0 Vdc
Coil Resistance (±10%)	19 Ω	103 Ω	1890 Ω
Energy, Magnetic, Max.	.05 J	.05 J	.05 J

Coil resistance rated at 25°C

For factory-direct application assistance, dial 800-253-4560, ext. 2055, or 805-220-2055.

AP90X - 90 Amps SPUD Contactor

Product Facts

- 90 A carry, 350 A overload @ 270 Vdc
- Same size and weight as AP50X
- Versatile power, voltage, and current operating range
- Ideal for circuit protection and control
- Bi-directional switching
- Fast operate and release time
- Low power consumption
- Vacuum-sealed contacts; can operate in harsh environments
- Space-rated version built in accordance with customers SCD
- Meets many requirements of MIL-PRF-32085

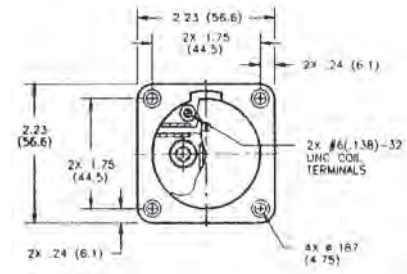
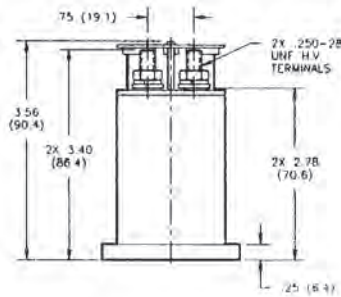

Contact Ratings*

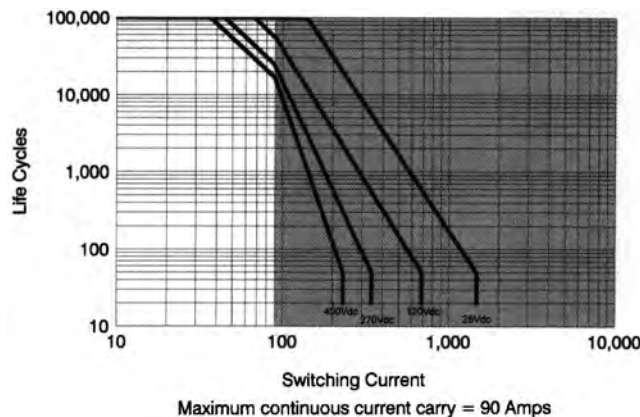

*Based on data extrapolated from qualification at 270 Vdc with resistive load. Since each application is unique, user is encouraged to verify rating in actual application.

Product Specifications

- Contact Arrangement** — SPST-NO
- Contact Form** — X
- Rated Resistive Load @ 270 Vdc** — 90 A
- Continuous Current Carry, Max.** — 90 A
- Overload @ 270 Vdc** — 350 A
- Contact Resistance, Max.** — 2 mohm

- Dielectric at Sea Level** — Coil to Power Terminals — 1,800 Vrms
All Other Points — 2,000 Vrms
- Shock, 11ms, 1/2 Sine (Peak)** — 30 g
- Vibration, Sinusoidal (55-2000 Hz, Peak)** — 20 g
- Operating Ambient Temperature Range** — -55°C to +85°C
- Load Life @ 270 Vdc, Min.** — 25,000 cycles

- Operate Time, Excluding Bounce, Max.** — 27 ms
- Release Time, Max.** — 10 ms
- Bounce Time, Max.** — 8 ms
- Insulation Resistance @ 500 Vdc, Min.** — Initial — 100 mohm
End of Life — 50 mohm
- Weight, Nominal** — 454 gram (16 oz.)

Coil Data

Volts, Nominal	12	28	120
Pickup, Max.	9.9 Vdc	23 Vdc	99 Vdc
Dropout, Min.	.4 Vdc	1.0 Vdc	4.0 Vdc
Coil Resistance (±10%)	19 Ω	103 Ω	1890 Ω
Energy, Magnetic, Max.	.05 J	.05 J	.05 J

Coil resistance rated at 25°C

Ordering Information

- Sample Part Number** ▶ **AP90 X B 5 7**
- Series:** _____
- Contact Form:** _____
X = SPST-NO Double Make
- Coil Voltage:** _____
A = 12 Vdc, Stud Terminals
B = 28 Vdc, Stud Terminals
C = 120 Vdc, Stud Terminals
- Power Terminals:** _____
5 = Stud Terminals
- Mounting:** _____
7 = Panel Mount

For factory-direct application assistance, dial 800-253-4560, ext. 2055, or 805-220-2055.

AP150X (Form X, Electrically Held)

CZONKA Contactor

Product Facts

- 150 A carry, 500 A overload @ 270 Vdc
- Suitable for circuit protection, control, and battery switching
- Versatile power, voltage, and current operating range
- Bi-directional switching
- Electrically held and latching coil versions
- Fast operate and release time
- Low power consumption
- Vacuum-sealed contacts; can operate in harsh environments
- Space-rated version built in accordance with customers SCD
- Meets many requirements of MIL-PRF-32085

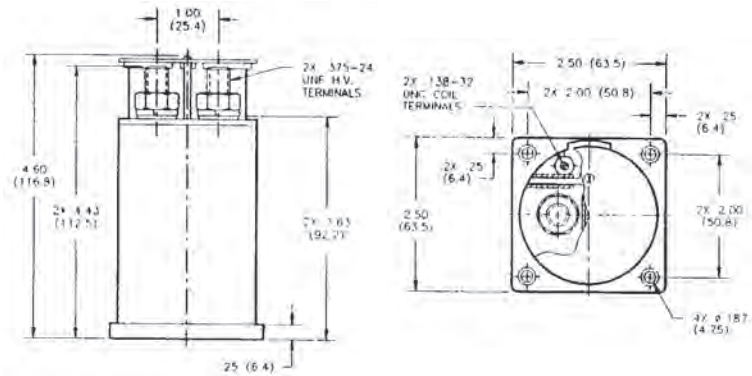

Product Specifications

- Contact Arrangement** — AP150X — SPST-NO
- Contact Form** — AP150X — X
- Rated Resistive Load @ 270 Vdc** — 150 A
- Continuous Current Carry, Max.** — 150 A
- Overload Make & Break @ 270 Vdc** — 400/500 A*
- Contact Resistance, Max.** — 1 mohm
- Dielectric at Sea Level** — Power Terminals to Terminal — 2,000 Vrms
Power Terminals to All Other Points — 1,800 Vrms
- Shock, 11ms, 1/2 Sine (Peak)** — 35 g
- Vibration, Sinusoidal (55-2000 Hz, Peak)** — 20 g
- Operating Ambient Temperature Range** — -55°C to +85°C
- Load Life @ 270 Vdc, Min.** — 10,000 cycles
- Operate Time (28 Vdc, 25°C)** —
- Close (Includes Bounce), Typ.** — AP150X — 35 ms
- Bounce (After Close Only), Max.** — AP150X — 8 ms
- Open (Includes Arcing), Max.** — AP150X — 10 ms
- Insulation Resistance @ 500 Vdc, Min.** — Initial/End of Life — 100 mohm/50 mohm
- Weight, Nominal** — 1.66 lb (0.753 kg)

Note:
*500 = at beginning of life which is 0 to 5,000 cycles, 400 = at end of life which is 5,000 to 10,000 cycles.

Contact Ratings*

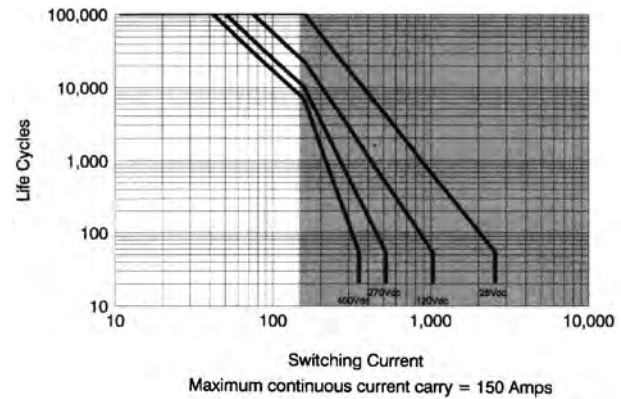

*Based on data extrapolated from qualification at 270 Vdc with resistive load. Since each application is unique, user is encouraged to verify rating in actual application.

Coil Data

	AP150X	AP150P
Voltage, Nominal*	28 Vdc	28 Vdc
Pickup (Close), Max.	23 Vdc	20 Vdc
Dropout (Open), Max.	1.0 Vdc	20 Vdc
Coil Resistance @ 25°C (10%)	52 Ω	13 Ω**
Coil Duty, Recommended	Continuous	100 ms to Toggle
Coil Energy, Max.	0.10 J	0.10 J
Coil Clamping	2.5 x nom.	500W/ms TVS

*12, 120 Vdc, or other special coil voltages available upon request.

**2 coils are used, both are high common. Switch coil power from low side. High side coil power switch is a special order.

Ordering Information

Sample Part Number ▶

Series: AP150 X B 5 7
 Contact Form: _____
 X = SPST-NO Electrically Held

Coil Voltage: _____
 A = 12 Vdc, Stud Terminals, .138-32
 B = 28 Vdc, Stud Terminals, .138-32
 C = 120 Vdc, Stud Terminals, .138-32

Power Terminals: _____
 5 = Stud Terminals, .375-24

Mounting: _____
 7 = Panel Mount

For factory-direct application assistance, dial 800-253-4560, ext. 2055, or 805-220-2055.

AP265 (Form X, Electrically Held) & AP265P (Form P, Latching) 265 Amps

CZONKA II Contactor

Product Facts

- 265 A carry, 1000 A overload @ 270 Vdc
- Bi-directional power switching
- Auxiliary Contacts
- Electrically held and latching coil versions
- Built-in coil drivers for electrically held (5W hold) and latching (coil pulser)
- Coil drivers EMC qualified to most of the requirements of MIL-STD-461D
- Versatile power, voltage, and current operating range
- Excellent for safety disconnect and transfer switch applications
- Designed for main generator loads
- Suitable for circuit protection and control
- Remote Power Controller version with overload protection available — contact factory for more information
- Hermetically-sealed contacts; can operate in harsh environments
- Space-rated version built in accordance with customers SCd
- Meets many requirements of MIL-PRF-32085

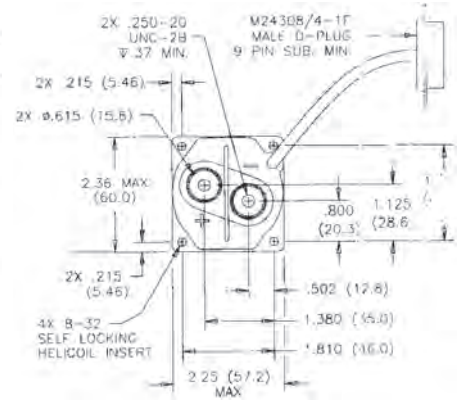
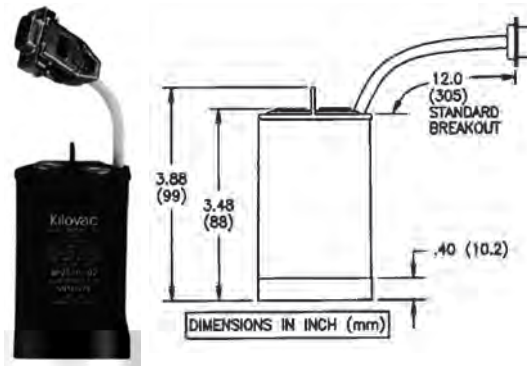

Product Specifications

Contact Arrangement Mains —
 AP265X — Form X — SPST-NO
 Form A — 2 x SPST-NO
 AP265P — Form X — SPST
 Form A — 2 x SPST

Polarity (Carry and Switching) —
 Bi-directional

Rated Resistive Load @ 270 Vdc —
 265 A

Continuous Current Carry, Max. —
 265 A

Overload Current @ 270 Vdc, Max. —
 Make and Break — 600 A
 Break Only — 1000 A

Contact Resistance, Max. —
 0.3 mohm

Dielectric at Sea Level (< 1 mA leakage) —
 Power Terminals to Terminal — 1,000 Vrms
 Power Terminals to All Other Points — 1,000 Vrms

Shock, 11ms, 1/2 Sine (Peak) —
 25 g

Vibration, Sinusoidal (55-2000 Hz, Peak) — 10 g

Operating Ambient Temperature Range — -55°C to +85°C

Load Life @ 270 Vdc, Min. —
 See graph above

Operate Time (28 Vdc, 25°C) —
Close (Includes Bounce), Typ. —
 AP265X — 20 ms
 AP265P — 10 ms

Bounce (After Close Only), Max. —
 5 ms

Open (Includes Arcing), Max. —
 15 ms

Insulation Resistance @ 500 Vdc, Min. —
 Initial/End of Life — 100 mohm/50 mohm

Weight, Nominal —
 1.7 lb (0.77 kg)

Electrical Life Cycles vs Power Switching

(Data from 270 Vdc testing @ 265A, 95% Weibull Reliability)

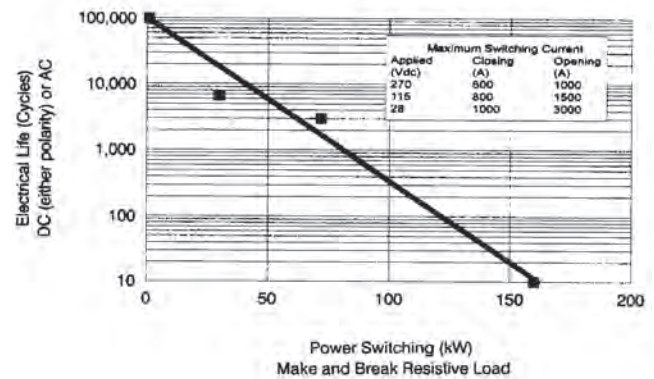

Coil Data

	AP265X	AP265P
Type Driver	"PWM" Econ.	Pulser
Voltage, Nominal	28 Vdc	28 Vdc
Pickup (Close), Max.	20 Vdc	12 Vdc
Dropout (Open), Max.	11 Vdc	12 Vdc
Current @ 28 V, 25°C		
Inrush	1.8 A	2.6 A
Holding (Standby)	0.20 A	<0.05 A
Inrush Time, Max.	100 ms	100 ms

Ordering Information

Sample Part Number ▶ **AP265 X E 9 7**

Series: _____

Contact Form: _____
 X = SPST-NO, Electrically Held
 P = SPST, Latching

Coil Voltage: _____
 E = 28 Vdc

Power Terminals: _____
 9 = Female Threads, .250-20

Mounting: _____
 7 = Panel Mount, Helcoil Locking

For factory-direct application assistance, dial 800-253-4560, ext. 2055, or 805-220-2055.

AP350X "BUBBA" Contactor 500 Amps

Product Facts

- 500 A carry, 1200 A make, 3000 A break @ 270 Vdc
- Bi-directional power switching
- Auxiliary Contacts
- Built-in coil power economizing — 6 W holding
- Versatile power, voltage, and current operating range
- Excellent for safety disconnect and transfer switch applications
- Suited for circuit protection control
- Hermetically-sealed contacts; can operate in harsh environments
- Designed for main generator loads
- Space-rated version built in accordance with customers SCB
- Meets many requirements of MIL-PRF-32085



Product Specifications

Contact Arrangement with Auxiliary Contact (28 Vdc, 0.1 A) —
 Form X — SPST-NO
 Form A — SPST-NO

Rated Resistive Load @ 270 Vdc, 85°C — 350 A

Continuous Current Carry, Max., 25°C — 500 A

Overload Current @ 270 Vdc, Max. —
 Make (Closed Into) — 1200 A
 Break (Open) — 3000 A

Contact Resistance, Max. — 0.2 mohm

Dielectric at Sea Level (< 1mA leakage) —
 Open Power Terminal to Terminal — 2,000 Vrms
 Closed Power Terminals to All Other Points — 2,000 Vrms

Shock, 11ms, 1/2 Sine (Peak) — 25 g

Vibration, Sinusoidal (55-2000 Hz, Peak) — 10 g

Operating Ambient Temperature Range — -55°C to +85°C

Load Life @ 270 Vdc, Min. — See graph above

Operate Time @ 25°C —
Close (Includes Bounce), Typ. — 35 ms

Bounce (Occurs When Closing), Max. — 5 ms

Open (Includes Arcing), Max. — 20 ms

Insulation Resistance @ 500 Vdc, Min. —
 Initial/End of Life — 100 mohm/50 mohm

Weight, Nominal — 3.35 lb (1.52 kg)

Coil Data

AP350X	
Type Driver	"PWM" Econ.
Voltage, Nominal	28 Vdc
Pickup (Close), Max.	20 Vdc
Dropout (Open), Max.	11 Vdc
Current @ 28 V, 25°C	
Inrush	2.1 A
Holding (Standby)	0.21 A
Inrush Time, Max.	200 ms

For factory-direct application assistance, dial 800-253-4560, ext. 2055, or 805-220-2055.

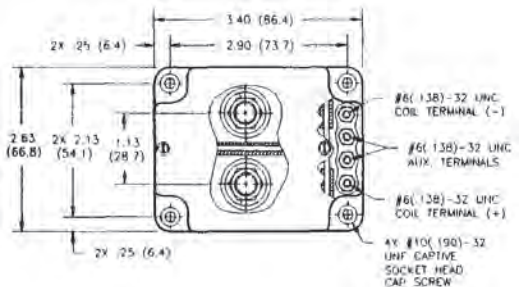
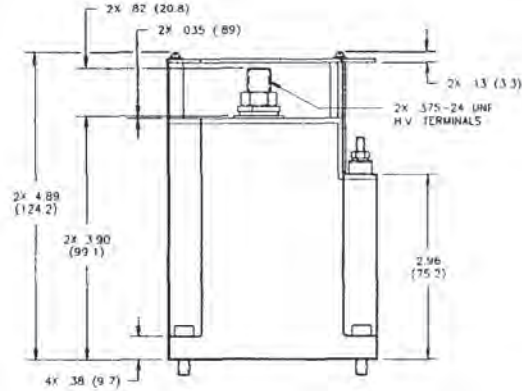

Electrical Life Cycles vs Power Switching

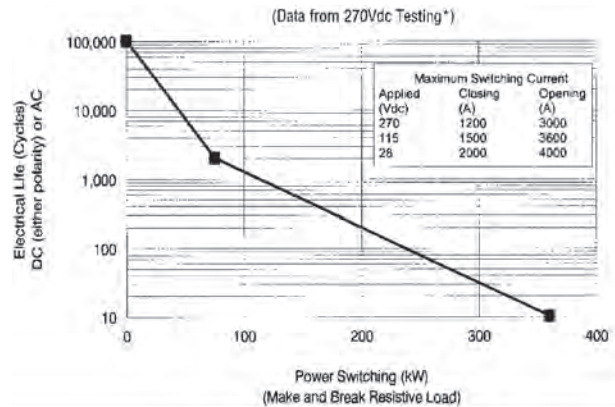

*Failure mode: Dielectric withstand voltage test @ 2000 Vdc, power terminal to terminal, leakage exceeds 1.0 A. Current Carry: 500 A @ 25°C. Derate 2.5 A/°C to 350 A @ 85°C for still air, no heat sink, AWG# 00 conductor.

Ordering Information

Sample Part Number ▶ **AP350 X B 5 7**

Series: _____

Contact Form: _____
 X = SPST-NO Double Make

Coil Voltage: _____
 B = 28 Vdc, Stud Terminals

Power Terminals: _____
 5 = Screw Terminals

Mounting: _____
 7 = Panel Mount, captive bolts

Refer to EV500 Sales Drawing for complete specifications.

EV250-1A & 1B 400 Amps CZONKA-II EVX Make & Break Load Switching

Product Facts

- Hydrogen dielectric for power switching high current loads
- 400 A carry, 2,500 A interrupt @ 320 Vdc
- Suited for circuit protection, control, battery switching, and main power safety disconnect
- Versatile power, voltage, and current operating range: 28-1800 Vdc tested
- Low-cost compact version for volume production applications. Requires external coil economizer (PWM or lower hold voltage)
- “Hammer effect” mechanism breaks light contact welds
- “Super-sealed” environment chamber uniquely protects ALL moving parts
- Can operate in harsh environments
- Moving contact rotates to provide fresh contact surface for low contact resistance and low power consumption
- Sealed control connector. Mating connector with flying leads Part Number 2005 available, see page 7-95
- Logic control enabled by external economizer Part Number 9913
- High temperature (135°C) model with 10 inch flying leads available (-4A — Call TE for sales drawing)
- Bi-directional power switching
- Fast operate and release time

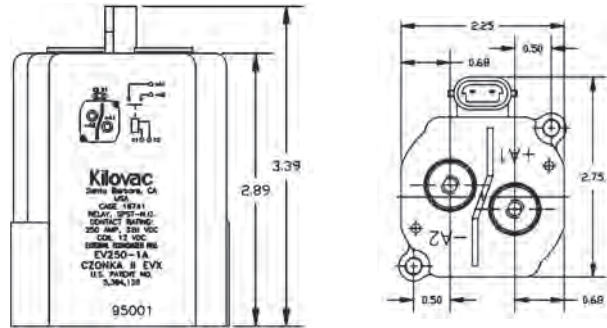

Note: Dimensions in inches. Multiply values by 25.4 for dimensions in mm.

Product Specifications

Contact Arrangement — SPST-NO
Contact Form — X
Continuous Current Carry, Max. — 400 A; 6.5 Minutes — 500 A
Break Current @ 320 Vdc — 2,500 A
Contact Resistance, Max. — 0.0003 ohm
Contact Resistance, Typ. — 0.0001 – 0.0002 ohm
Dielectric at Sea Level (Leakage < 1mA) — 2,200 Vrms
Shock, 11ms, 1/2 Sine (Peak), Operating — 30 g
Vibration, Sinusoidal (80-2000 Hz, Peak) — 20 g
Operating Ambient Temperature Range — -40°C to +85°C
Load Life — See chart on next page
Operate Time, @ 25°C —
Close (Includes Bounce), Typ. — 30 ms
Bounce (After Close Only), Max. — 5 ms
Open (Includes Arcing), Max. — 15 ms
Insulation Resistance @ 500 Vdc, Min. — 100 mohm
Weight, Nominal — 1.54 lb (0.7 kg)

Contact Ratings*

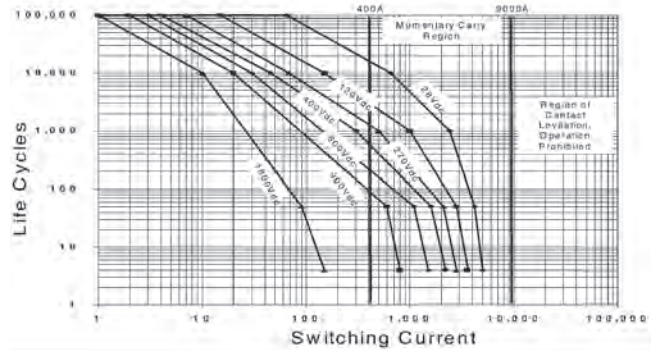

*For circuit conditions and actual data refer to the EV250 hot switch study. Since each application is unique, user is encouraged to verify rating in actual application.

Coil Data***

	EV250-1A	EV250-1B
Voltage, Nominal*	12 Vdc	24 Vdc
Pickup (Close), Max.	8.3 Vdc	16.6 Vdc
Continuous Hold, Max./Min.**	5.1/3.8 Vdc	10.2/7.6 Vdc
Dropout (Open), Min.	0.88 - 3.3 Vdc	2.4 - 6.6 Vdc
Coil Resistance @ 25°C, ±10%	3 Ω	12 Ω
Coil Energy, Max.	0.2 J	0.2 J
Coil Clamping	3 x nom.	3 x nom.

*Do not apply continuously. Requires external coil economizer. Other special coil voltages available upon request.

**At maximum continuous current and maximum ambient temperature. Hold voltage must be maintained within the limits specified to keep contacts closed and to prevent coil overheating.

***Do not use a free wheeling diode or capacitor across the coil.

Ordering Information

Sample Part Number ►

EV250-1 A

Series: _____

Coil Voltage: _____

A = 12 Vdc, Nominal

B = 24 Vdc, Nominal

For factory-direct application assistance, dial 800-253-4560, ext. 2055, or 805-220-2055.

For detailed specifications and recommendations, refer to the EV250-1A & B sales drawings.

EV250-1A & 1B 400 Amps CZONKA-II EVX Make & Break Load Switching (Continued)

Current vs Time

CONTACTS CLOSED INTO 70% AND 90% CAPACITOR PRE CHARGE

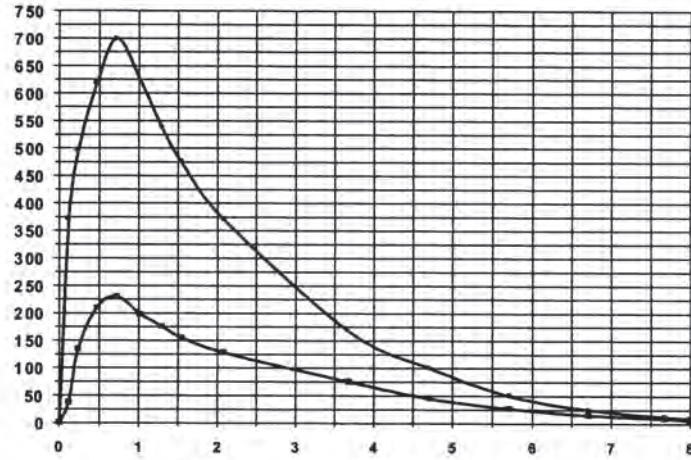

Life Ratings and Qualification Test Plan

Test #	Normal Operations		Abnormal Operations	
	1	2	3	4
Current	Reference Graph and Test Circuit Diagram (Sht. 8)		-250 A	2500 A
Voltage			320 V	320 V
Load Type	Capacitive	Capacitive	Resistive	Resistive
% Pre Charge	90%	70%	NA	N/A
Switch Mode	Make Only	Make Only	Make/Break	Break Only
Sequence				
1	10K cycles	10 cycles	2	2
2	10K	10	2	—
3	10K	10	2	—
4	10K	10	2	2
5	10K	10	2	—
Etc.	Continue Cycling to Relay Failure			

The testing objective is to verify proper relay function for a given number of consecutive and cumulative cycles under both normal and abnormal conditions in a variety of load switching applications. The life rating of 40K cycles minimum was calculated with 95% Weibull reliability.

**Electrical Data
(Over Temperature Range —
Max. Terminal Temp. = 200°C)**

Make/Break Life for Capacitive & Resistive Loads at 320 Vdc^{1,2} —

@ 90% Capacitive Pre-Charge — 50,000 cycles

@ 70% Capacitive Pre-Charge — 50 cycles

@ -250 A (2 Consecutive, Reverse Polarity)¹ — 10 cycles

@ 3300 A (Break only, 2 Consecutive)¹ — 4 cycles

Mechanical Life — 100,000 cycles

Notes:

1 Resistive load includes inductance L = 25 µH. Load @ 2500 A tested @ 200 µH.

2 Conductor: 2 each of copper 54 mm² (AWG 0) required for > 250 A carry. 1 Copper (AWG 0) conductor recommended for ≤ 250 A

For factory-direct application assistance, dial 800-253-4560, ext. 2055, or 805-220-2055.

EV250-2A & 2B 400 Amps CZONKA II EVX Make & Break Load Switching

Product Facts

- Hydrogen dielectric for power switching high current loads
- 400 A carry, 2,500 A interrupt @ 320 Vdc
- Suited for circuit protection, control, battery switching, and main power safety disconnect
- Versatile power, voltage, and current operating range: 28-1800 Vdc tested
- Internal coil economizer provides:
 - 4W typical hold power independent of temperature & voltage range
 - EMI spectrum tested and approved
 - Built-in coil suppression
- “Hammer effect” mechanism breaks light contact welds
- Hermetically “Super-sealed” environment chamber uniquely protects ALL moving parts
- Can operate in harsh environments
- Moving contact rotates to provide fresh contact surface for low contact resistance and low power consumption
- Sealed control connector. Mating connector with flying leads Part Number 2005 available
- Special versions available:
 - Economical (-8A/B) for light duty power switching (without arc blowout magnets)
 - 10 inch flying leads model (-7A)

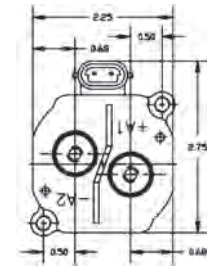
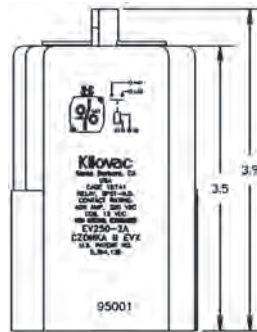

Note: Dimensions in inches. Multiply values by 25.4 for dimensions in mm.

Product Specifications

Contact Arrangement — SPST-NO
Contact Form — X
Continuous Current Carry, Max. — 400 A; 6.5 Minutes — 500 A
Break Current @ 320 Vdc — 2,500 A
Contact Resistance, Max. — 0.0003 ohm
Contact Resistance, Typ. — 0.0001 – 0.0002 ohm
Dielectric at Sea Level (Leakage < 1mA) — 2,200 Vrms
Shock, 11ms, 1/2 Sine (Peak), Operating — 30 g
Vibration, Sinusoidal (80-2000 Hz, Peak) — 20 g
Operating Ambient Temperature Range — -40°C to +85°C
Load Life — See chart on next page
Operate Time, @ 25°C —
Close (Includes Bounce), Typ. — 18 ms
Bounce (After Close Only), Max. — 5 ms
Release Time (Includes Arcing), Max. — 15 ms
Insulation Resistance @ 500 Vdc, Min. — 100 mohm
Weight, Nominal — 1.76 lb (0.8 kg)

Contact Ratings*

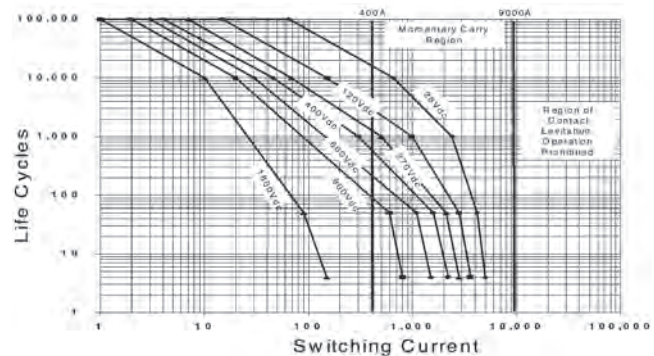

*For circuit conditions and actual data refer to the EV250 hot switch study. Since each application is unique, user is encouraged to verify rating in actual application.

Coil Data**

	EV250-2A	EV250-2B
Voltage, Nominal*	12 Vdc	24 Vdc
Pickup (Close), Max.	9 Vdc	18 Vdc
Hold, Min.	7 Vdc	14 Vdc
Dropout (Open), Min.	5 Vdc	10 Vdc
Current (@ VsNom / 25°C)		
Inrush	2.8 A	1.8 A
Holding, Standby	0.34 A	0.11 A
Inrush Time, Max.	200 ms	200 ms

*Other special coil voltages available upon request.

**Do not use a free wheeling diode or capacitor across the coil. Built in suppression limits back EMF to zero volts.

Ordering Information

Sample Part Number ► **EV250 -2 A**

Series: _____
Model: _____
 2 = With Blowout Magnets
 8 = Without Blowout Magnets
 7 = 10" Flying Leads (12 V, with Magnets Only)

Coil Voltage: _____
 A = 12 Vdc, Nominal
 B = 24 Vdc, Nominal

For detailed specifications and recommendations, refer to the EV250-2A & B or 7A sales drawings.

For factory-direct application assistance, dial 800-253-4560, ext. 2055, or 805-220-2055.

EV250-2A & 2B 400 Amps CZONKA II EVX Make & Break Load Switching (Continued)

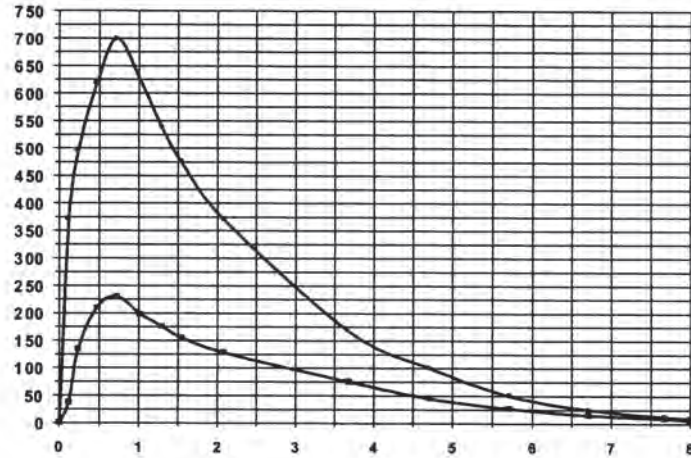
CONTACTS CLOSED INTO 70% AND 90% CAPACITOR PRE CHARGE

Life Ratings and Qualification Test Plan

Test #	Normal Operations		Abnormal Operations	
	1	2	3	4
Current	Reference Graph and Test Circuit Diagram (Sht. 8)		-250 A	2500 A
Voltage			320 V	320 V
Load Type	Capacitive	Capacitive	Resistive	Resistive
% Pre Charge	90%	70%	NA	N/A
Switch Mode	Make Only	Make Only	Make/Break	Break Only
Sequence				
1	10K cycles	10 cycles	2	2
2	10K	10	2	—
3	10K	10	2	—
4	10K	10	2	2
5	10K	10	2	—
Etc.	Continue Cycling to Relay Failure			

The testing objective is to verify proper relay function for a given number of consecutive and cumulative cycles under both normal and abnormal conditions in a variety of load switching applications. The life rating of 40K cycles minimum was calculated with 95% Weibull reliability.

**Electrical Data
(Over Temperature Range —
Max. Terminal Temp. = 200°C)**
Make/Break Life for Capacitive & Resistive Loads at 320 Vdc^{1,2} —

@ 90% Capacitive Pre-Charge —

50,000 cycles

@ 70% Capacitive Pre-Charge —

50 cycles

 @ -250 A (2 Consecutive, Reverse Polarity)¹ — 10 cycles

 @ 3300 A (Break only, 2 Consecutive)¹ — 4 cycles

Mechanical Life — 100,000 cycles

Notes:

1 Resistive load includes inductance
L = 25 μH. Load @ 2500 A tested
@ 200 μH.

2 Conductor: 2 each of copper
54 mm² (AWG 0) required for
> 250 A carry. 1 Copper (AWG 0)
conductor recommended for
≤ 250 A

For factory-direct application assistance,
dial 800-253-4560, ext. 2055, or
805-220-2055.

EV500 "BUBBA" Contactor 600 Amps, Make & Break Load Switching

Product Facts

- Very high power sealed contactor
- Hydrogen dielectric for power switching high current loads
- Excellent for safety disconnect and transfer switch applications
- Suited for circuit protection control
- Hermetically "Super-sealed" environment uniquely protects contacts and all moving parts; can operate in harsh environments
- 600-1000 A continuous carry, dependent on temperature and conductors used
- 3,300 A interrupt, 1,000 A make, @ 320 Vdc
- 12 and 24 volt coil control options. Call TE for custom options
- 360 kW power switch capable
- 200°C hot power terminals capable
- Bi-directional power switching
- Auxiliary contacts optional
- Built-in dual power coil economizer, 8W holding typical
- Versatile power, voltage, and current operating range: 28-1800 Vdc*

Product Specifications

- Contact Arrangement with Auxiliary Contacts** —
 Form X — SPST-NO
 Form A — SPST-NO
- Rated Resistive Load @ 270 Vdc, 85°C (Continuous/10 sec)** —
 600 A/1,600 A
- Continuous Current Carry, Max., 25°C** 1 — 750 A
- Overload Current @ 320 Vdc, Max.** —
 Make (Closed Into) — 1,000 A
 Break (Open) — 3,300 A
- Contact Resistance, Max.** —
 0.0002 ohm
- Dielectric at Sea Level (Leakage < 1mA)** —
 Open Power Terminal to Terminal — 2,000 Vrms
 Closed Power Terminals to All Other Points — 2,000 Vrms
- Shock, 11ms, 1/2 Sine (Peak), Operating** — 30 g
- Vibration, Sinusoidal (80-2000 Hz, Peak)** — EV500-5 — 5 g
 EV500-4 — 10 g
- Operating Ambient Temperature Range** — -40°C to +85°C
- Load Life (Mechanical/Electrical)** 2 — See next page
- Operate Time @ 25°C** —
 Close (Includes Bounce), Typ. — 40 ms
- Bounce (After Close Only), Max.** — 5 ms
- Release Time (Includes Arcing), Max. at 2500 A** — 20 ms
- Insulation Resistance @ 500 Vdc, Min.** — 100 mohm
- Weight, Nominal** — 3.38 lb (1.53 kg)

Notes:

1. Current Carry: 750 A @ 25°C. Derate 2.5 A/°C to 600 A @ 85°C for still air, no heat sink. Reference National Electric Code for specific conductor size recommendation versus current. For > 600 A carry, call TE and request the "EV500 Current Carry study" for additional data.
2. See EV500 sales drawing for complete specifications, including normal capacitive pre-charge make, plus abnormal make and break ratings.

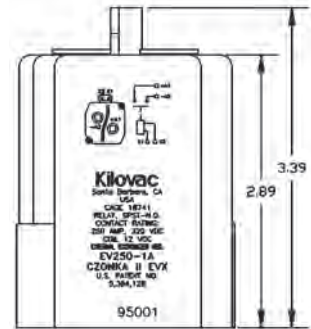

Electrical Life Cycles vs Power Switching

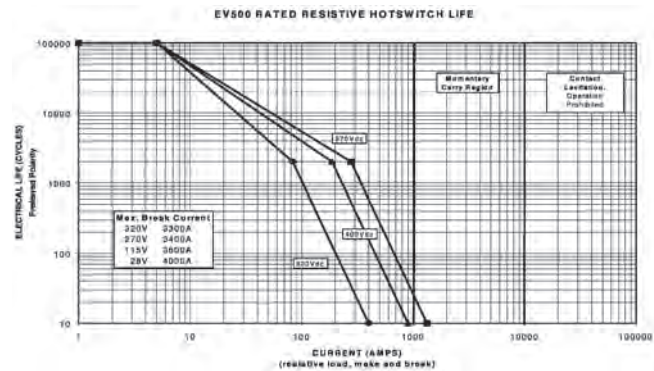

*Failure mode: Dielectric withstand voltage test @ 2000 Vdc, power terminal to terminal, leakage exceeds 1.0 A.

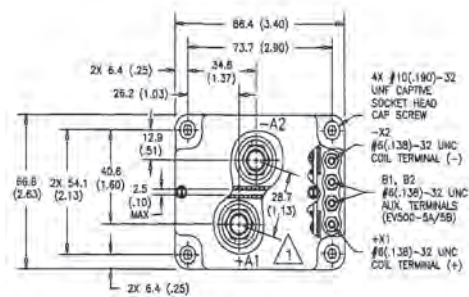

For factory-direct application assistance, dial 800-253-4560, ext. 2055, or 805-220-2055.

Coil Data

	12 V	24 V
Type Driver	2 Coil Electronic	
Volts, Nominal*	12 Vdc	24 Vdc
Pickup (Close), Max.	9.9 Vdc	19.7 Vdc
Hold, Min.	9 Vdc	18 Vdc
Dropout (Open), Min.	2 Vdc	4 Vdc
Current (@ VsNom / 25°C)		
Inrush	3.3 A	1.7 A
Holding, Standby	0.74 A	0.37 A
Inrush Time, Max.	300 ms	300 ms

Ordering Information

- Sample Part Number** ▶ **EV500 4 A**
- Series:** _____
- Auxiliary Contacts:** _____
 4 = Without
 5 = With
- Coil Voltage:** _____
 A = 12 Vdc
 B = 24 Vdc

Refer to EV500 Sales Drawing for complete specifications.

EV500 “BUBBA” Contactor 600 Amps, Make & Break Load Switching (Continued)

Current vs Time

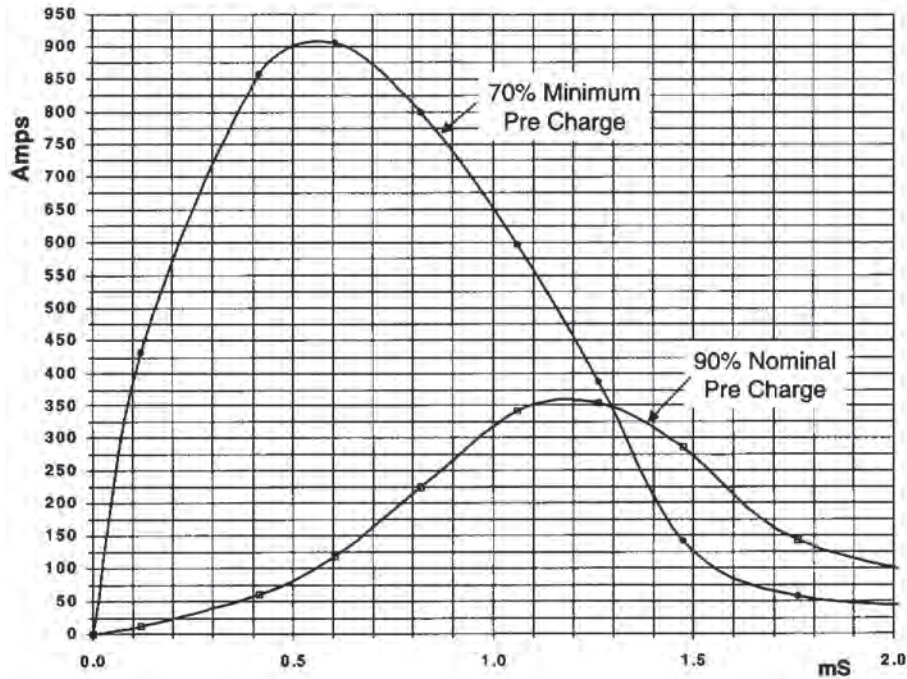

Life Ratings and Qualification Test Plan

Test #	Normal Operations		Abnormal Operations	
	1	2	3	4
Current	Reference Graph and Test Circuit Diagram (Sht. 8)		-250 A	3300 A
Voltage			320 V	320 V
Load Type	Capacitive	Capacitive	Resistive	Resistive
% Pre Charge	90%	70%	NA	N/A
Switch Mode	Make Only	Make Only	Make/Break	Break Only
Sequence				
1	10K cycles	10 cycles	2	2
2	10K	10	2	—
3	10K	10	2	—
4	10K	10	2	2
5	10K	10	2	—
Etc.	Continue Cycling to Relay Failure			

The testing objective is to verify proper relay function for a given number of consecutive and cumulative cycles under both normal and abnormal conditions in a variety of load switching applications. The life rating of 40K cycles minimum was calculated with 95% Weibull reliability.

**Electrical Data
(Over Temperature Range —
Max. Terminal Temp. = 200°C)**

Make/Break Life for Capacitive & Resistive Loads at 320 Vdc 1,2 —

@ 90% Capacitive Pre-Charge — 50,000 cycles

@ 70% Capacitive Pre-Charge — 50 cycles

@ -250 A (2 Consecutive, Reverse Polarity) 1 — 10 cycles

@ 3300 A (Break only, 2 Consecutive) 1 — 4 cycles

Mechanical Life — 100,000 cycles

Notes:

1 Resistive load includes inductance L = 25 µH.

2 Testing is limited at this time. Consult TE for official ratings.

For factory-direct application assistance, dial 800-253-4560, ext. 2055, or 805-220-2055.

PD350X - 500 Amps "BUBBA" Contactor, Make & Break Load Switching

Product Facts

- 500 A carry, 1300 A make overload, 3000 A break overload, @ 320 Vdc
- Hydrogen dielectric for power switching high current loads
- Auxiliary contacts
- Coil power economizing — 8 W holding
- Versatile power, voltage, and current operating range
- Excellent for safety disconnect and transfer switch applications
- Suited for circuit protection and control
- Bi-directional power switching
- Hermetically-sealed contacts; can operate in harsh environments
- Fast operate and release time
- Low power consumption

Product Specifications

- Contact Arrangement** — Form X — SPST-NO
- Auxiliary Contact (28 Vdc, 0.1 A)** — SPST-NO
- Rated Resistive Load @ 320 Vdc** — 300 Amps @85°C
- Continuous Current Carry, Max. @ 50°C** — 500 A
- Overload Current @ 320 Vdc** — Make — 1,300 A
Break — 3,300 A
- Load Life, @ 320 Vdc, Min.** — See chart at right
- Contact Resistance, Max.** — End of Life — 0.0002 ohm
- Dielectric at Sea Level** — Power Terminals to Coil and All Other Points — 1,800 Vrms
- Shock, 11ms, 1/2 Sine (Peak)** — 30 g
- Vibration, Sinusoidal (55-2000 Hz, Peak)** — 5 g
- Operating Ambient Temperature Range** — -40°C to +85°C
- Operate Time, Including Bounce, Max., 25°C** — 40 ms
- Release Time, Max.** — 20 ms
- Bounce Time, Max.** — 5 ms
- Insulation Resistance @ 500 Vdc, Min.** — Initial — 100 mohm
End of Life — 50 mohm
- Weight, Nominal** — 3.4 lb (1.52 kg)

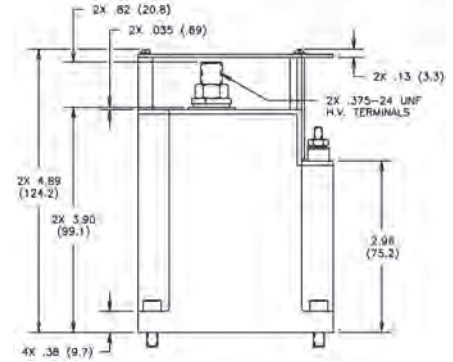

Electrical Life Cycles vs Power Switching

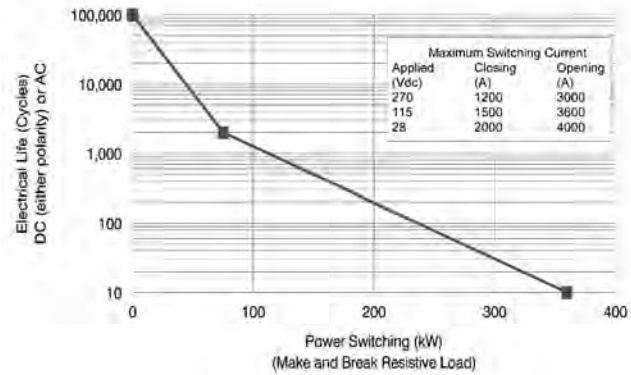

*Failure Mode: Dielectric withstand voltage test @ 2000 Vdc, power terminal to terminal, leakage exceeds 1.0 mA. Current carry: 500 A @ 25°C. Derate 2.5 A/°C to 350 A @ 85°C for still air, no heat sink, AWG# 00 conductor.

For factory-direct application assistance, dial 800-253-4560, ext. 2055, or 805-220-2055.

Contact Rating Notes:

1. Maximum continuous current carry = 500A @ 25°C = T_A, derate 5A/°C for higher temp.
2. Maximum interrupt power (break only) = 1 MW @ 200mH inductance.

Coil Data

Volts, Nominal	12 V	24 V
Pickup, Max. @ 65°C	9.9 Vdc	19.7 Vdc
Hold, Max. @ 65°C	8.5 Vdc	17 Vdc
Dropout, Min. @ -35°C	1.2 Vdc	2.4 Vdc
Coil Power** 25°C		
During Pickup (300 ms)	43 W	43 W
While Holding	8 W	8 W
Energy, Magnetic, Max.***	.26 J	.26 J

**Two coils are employed for power economizing subsequent to pickup. During pickup both coils operate in parallel drawing 43 Watts momentarily. After pickup, the electronic economizing system leaves only the holding coil on, drawing 8 Watts @ 25°C. Economizing system includes transient voltage suppression.

***Coil energy absorbed internally -4x nominal voltage.

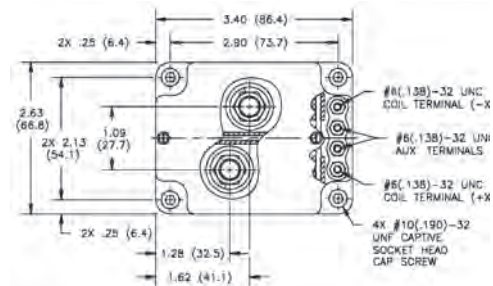

Ordering Information

Sample Part Number ▶

PD350 X B 5 7

Series:

Contact Form: X = SPST-NO, Double Make

Coil Voltage: A = 12 Vdc, Stud Terminals
B = 24 Vdc, Stud Terminals

Power Terminals: 5 = Stud Terminals

Mounting: 7 = Panel Mount, Captive Bolts

High Voltage Relays Quick Reference Guide

Contact Voltage Vdc	Isolation Voltage Vdc	Carry Current (Amps DC)	Power Switching	RF Ratings	Contact Form	Part Number Series
270 Vdc Aerospace	2000	5	Yes	No	SPST-NO	AP5A
	2000	5	Yes	No	SPST-NC	AP5B
	2000	5	Yes	No	SPDT	AP5C
	2000	10	Yes	No	SPST-NO	AP10A
	2000	10	Yes	No	SPST-NC	AP10B
	2000	10	Yes	No	SPDT	AP10P
	2000	15	Yes	No	SPST-Latch	AP44P
28 Vdc to 1800 Vdc	1800	5	Yes	No	SPST-NO	PD5A
	1800	5	Yes	No	SPST-NC	PD5B
	1800	10	Yes	No	SPST-NO	PD10A
	1800	10	Yes	No	SPST-NC	PD10B
	1800	10	Yes	No	SPST-Latch	PD10P
2.0 kV	2000	6	Carry Only	Yes	SPST-NO	S06CBA
	2000	15	Yes	Yes	SPDT	K45C
3.0 kV	3000	2	Carry Only	No	SPST-NO	S02DNA
	3500	8	Make Only	No	SPDT	HC-5
3.5 kV	3500	15	Yes	Yes	SPDT	HC-3*
	3500	25	Carry Only	Yes	SPDT	HC-1
	5000	8	Carry Only	No	SPST-NO	S06FNA218
5.0 kV	5000	30	Yes	Yes	SPST-NO	K41A
	5000	30	Yes	Yes	SPST-NC	K41B
	5000	30	Yes	Yes	SPDT	K41C
	5000	25	Yes	Yes	SPST-Latch	K41P
	5000	25	Yes	Yes	SPDT-Latch	K41R
	5000	35	Yes	Yes	SPST-Latch	K40P
7.0 kV	7000	6	Carry Only	Yes	SPST-NO	S06HBA
7.5 kV	7500	10	Make Only	No	DPDT	KM-13
	7500	10	Make Only	No	DPDT	KM-17
8.0 kV	8000	6	Carry Only	No	SPST-NC	S06JNB
	8000	8	Make Only	No	SPDT	HC-6
	8000	10	Yes	Yes	DPDT	H-18
	8000	12	Yes	Yes	SPST-NO	K47A
	8000	12	Yes	Yes	SPST-NC	K47B
	8000	15	Yes	No	SPDT	HC-4
	8000	25	No	No	SPDT	HC-2
	8000	50	Yes	Yes	SPST-Latch	K44P

*Consult factory for load switching level.

For factory-direct application assistance,
dial 800-253-4560, ext. 2055, or
805-220-2055.

KILOVAC High Voltage Relays Quick Reference Guide (Continued)

Contact Voltage Vdc	Isolation Voltage Vdc	Carry Current (Amps DC)	Power Switching	RF Ratings	Contact Form	Part Number Series
10 kV	10000	5	Yes	No	SPST-NO	S05LTA
	10000	5	Yes	No	SPST-NC	S05LTB
	10000	5-30	Special	No	SPST-NO	K81A
	10000	5-30	Special	No	SPST-NC	K81B
	10000	5-30	Special	No	SPDT	K81C
	10000	25	Special	Yes	SPST-NO	K43A
	10000	25	Special	Yes	SPST-NC	K43B
	10000	25	Special	Yes	SPDT	K43C
	10000	24	Special	Yes	SPDT-Latch	K43R
	10000	24	Special	Yes	SPST-Latch	K43P
12 kV	12000	30	Yes	Yes	DPDT	H-14
	12000	30	Yes	Yes	DPDT	H-16
15 kV	15000	5	Yes	No	SPST-NO	S05MTA
	15000	12	Make Only	No	SPDT	KC-15
	15000	12	Make Only	No	SPDT	KC-16
	15000	15	Yes	Yes	SPDT	H-8
	15000	15	Yes	No	SPDT	KC-14
	15000	15	Yes	No	SPDT	KC-18
	15000	30	Yes	No	SPDT	KC-12
	15000	30	Carry Only	Yes	4PDT	H-26
	15000	30	Yes	No	SPDT	KC-8
	15000	50	Carry Only	Yes	SPDT	KC-2
20 kV	15000	50	Carry Only	Yes	SPDT	KC-11
	20000	30	Special	Yes	DPDT	H-19
25 kV	25000	15	Make Only	No	SPST-NC	KC-38
	25000	18	Special	No	SPST-NO	K62A
	25000	18	Special	No	SPST-NC	K62B
	25000	18	Special	No	SPDT	K62C
	25000	30	Special	Yes	SPDT	H-17
	25000	30	Make Only	No	SPST-NO	KC-28
	25000	45	Special	No	SPST-NC	KC-32
	25000	55	Carry Only	Yes	SPST-NC	KC-30
	25000	65	Special	No	SPST-NO	KC-22
	25000	110	Carry Only	Yes	SPST-NO	KC-20
30 kV	30000	30	Special	Yes	SPST-NC	H-23
	30000	30	Special	Yes	SPST-NO	H-24
35 kV	35000	10	Make Only	No	SPDT	K60C
	35000	10	Make Only	No	SPST-NO	K61A
	35000	10	Make Only	No	SPST-NC	K61B
	35000	10	Make Only	No	SPDT	K61C
50 kV	50000	10	Make Only	No	SPDT	K64C
	50000	30	Special	No	SPDT	H-25
70 kV	70000	10	Make Only	No	SPST-NO	K70A
	70000	10	Make Only	No	SPST-NC	K70B
	70000	10	Make Only	No	SPDT	K70C

*Consult factory for load switching level.

For factory-direct application assistance, dial 800-253-4560, ext. 2055, or 805-220-2055.

AP5/AP10 Relays

Product Facts

- AP5 make and break 5 A; AP10 make and break 10 A @ 270 Vdc
- 20 A overload rating
- Latching actuator available for low power consumption
- Ideal for applications from 28 to 1000 Vdc
- Small size and weight
- Wide variety of mounting styles (see pages 54 and 55)
- No heat sinks required
- 2000 V isolation across open contacts
- Vacuum-sealed contacts; can operate in harsh environments
- Qualified to SAE ARD 50031
- Space-rated version built in accordance with customers SCD

Notes:

*The load terminals should always be connected as follows: Common Contact +; Other Contact -.
**10 amps for PC board connection.

Coil Data

Volts, Nominal	12	28	28 ²	120
Pickup, Max. ¹	10 Vdc	20 Vdc	16 Vdc	85 Vdc
Dropout, Min.	.3-6 Vdc	.7-12 Vdc	N/A	5-55 Vdc
Coil Resistance (±10%)	53 Ω	290 Ω	80 Ω	4700 Ω

Coil resistance rated at 25°C

Notes:

1. Value for AP5C is 24 for 28 Vdc coil & 100 for 120 Vdc coil
2. Latching

For factory-direct application assistance, dial 800-253-4560, ext. 2055, or 805-220-2055.

AP5A, AP5B, & AP5C Relays — 5 Amps

Product Specifications

Contact Arrangement —

AP5A — SPST-NO

AP5B — SPST-NC

AP5C — SPDT

Contact Form —

AP5A — A

AP5B — B

AP5C — C

Rated Resistive Load @ 270 Vdc — 5 A*

Continuous Current Carry, Max. — AP5A, AP5B, AP5C — 25 A**

Overload @ 270 Vdc —

AP5A, AP5B — 20 A

AP5C — 10 A

Contact Resistance, Max. —

10 mohm

Dielectric at Sea Level —

Coil to Case — 500 Vrms

All Other Points — 2,000 Vrms

Shock, 11ms, 1/2 Sine (Peak) —

AP5A, AP5B, AP5C — 50 g

Vibration, Sinusoidal (55-2000 Hz, Peak) — 10 g

Operating Ambient Temperature Range — -55°C to +85°C

Load Life @ 270 Vdc, Min. —

AP5A, AP5B — 50,000 cycles

AP5C — 10,000 cycles

Operate Time, Excluding Bounce, Max. —

AP5A, AP5B, AP5C — 7 ms

Release Time, Max. —

AP5A, AP5B, AP5C — 10 ms

Bounce Time, Max. —

AP5A, AP5B, AP5C — 3 ms

Insulation Resistance @ 500 Vdc, Min. —

Initial — 100 mohm

End of Life — 50 mohm

Weight, Nominal —

28 gram (1 oz.)

AP10A, AP10B, AP10P & AP11A Relays — 10 Amps

Product Specifications

Contact Arrangement —

AP10A — SPST-NO

AP10B — SPST-NC

AP10P — SPST Latching

Contact Form —

AP10A — A

AP10B — B

AP10P — P

Rated Resistive Load @ 270 Vdc — 10 A*

Continuous Current Carry, Max. — AP10A, AP10B — 25 A**

AP10P — 30 A**

Overload @ 270 Vdc — 20 A

Contact Resistance, Max. —

10 mohm

Dielectric at Sea Level —

Coil to Case — 500 Vrms

All Other Points — 2,000 Vrms

Shock, 11ms, 1/2 Sine (Peak) — 50 g

Vibration, Sinusoidal (55-2000 Hz, Peak) — 10 g

Operating Ambient Temperature Range — -55°C to +85°C

Load Life @ 270 Vdc, Min. —

AP10A — 10,000 cycles

AP10B, AP10P — 7,000 cycles

Operate Time, Excluding Bounce, Max. —

AP10A, AP10B — 7 ms

AP10P — 4 ms

Release Time, Max. —

AP10A, AP10B — 10 ms

AP10P — N/A

Bounce Time, Max. —

AP10A, AP10B — 3 ms

AP10P — 2 ms

Insulation Resistance @ 500 Vdc, Min. —

Initial — 100 mohm

End of Life — 50 mohm

Weight, Nominal —

28 gram (1 oz.)

Ordering Information

Sample Part Number ►

Series: _____

Contact Form: _____

A = SPST-NO

B = SPST-NC

C = SPDT

P = SPST Latching

Coil Voltage: _____

2 = 12Vdc, Bus Wire/PC Board

3 = 28 Vdc, Bus Wire/PC Board

5 = 120 Vdc, Bus Wire/PC Board

7 = 12 Vdc, Turret Terminals

8 = 28 Vdc, Turret Terminals

9 = 120 Vdc, Turret Terminals

A = 12 Vdc, Stud Terminals, Panel Mount

B = 28 Vdc, Stud Terminals, Panel Mount

C = 120 Vdc, Stud Terminals, Panel Mount

Power Terminals: _____

3 = Solder Connection/PC Board

4 = Flying Leads

5 = Stud Terminals, Panel Mount

Mounting: _____

2 = Flanged Mount

4 = Through Chassis Mount

5 = PCB Mount

7 = Panel Mount

7

KILOVAC 270+ Vdc
High Voltage Relays

AP5/AP10 Relays (Continued)

Through chassis style mounting with solder type power terminals and turret coil terminals (Available in forms A, B, & C)



AP5A834 Shown as Part Number Sample

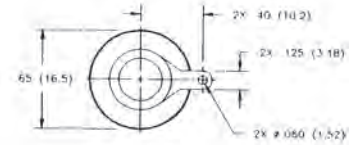
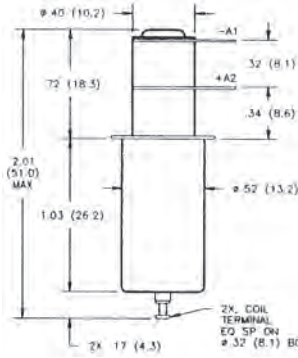

Through chassis style mounting with solder type power terminals and bus wire coil leads (Available in forms A, B, C, P)



AP10A334 Shown as Part Number Sample

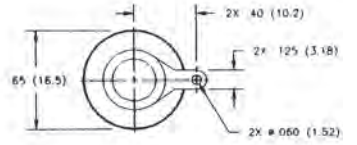
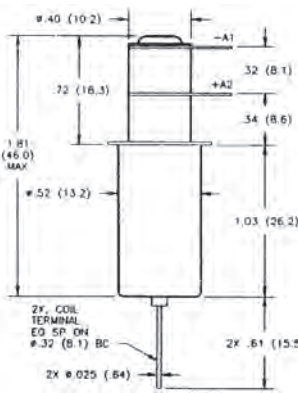

Flanged style mounting with solder type power terminals and turret coil terminals (Available in forms A, B, & C)



AP5C832 Shown as Part Number Sample

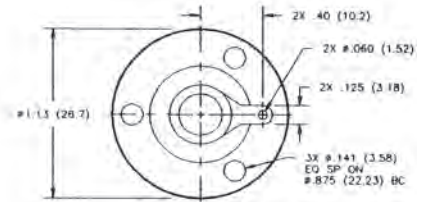
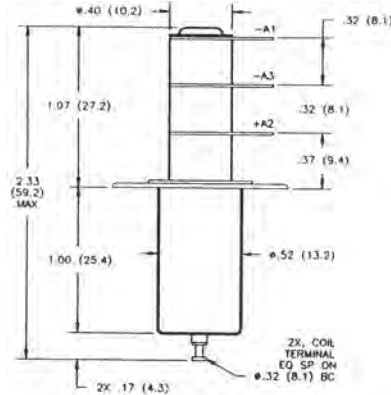

Flanged style mounting with solder type power terminals and bus wire coil leads (Available in forms A, B, C, P)



AP5R332 Shown as Part Number Sample

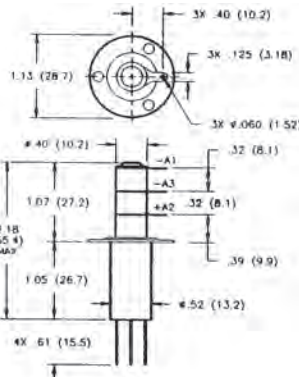

For factory-direct application assistance, dial 800-253-4560, ext. 2055, or 805-220-2055.

AP5/AP10 Relays (Continued)

PC board style mounting with PC board terminals (Available in forms A, B, & C)



AP10A335 Shown as Part Number Sample

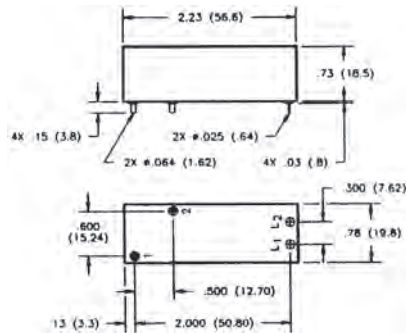

Panel style mounting with flying power leads and stud terminals (Available in forms A & B)



AP10AB47 Shown as Part Number Sample

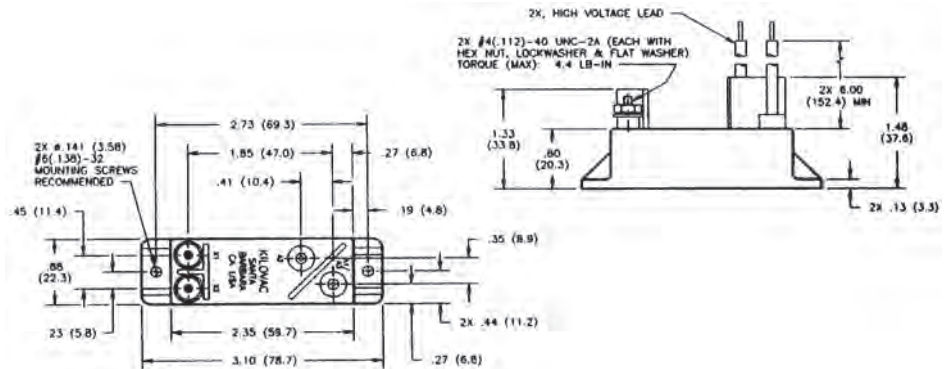

Panel style mounting with stud terminals (Available in forms A & B)



AP10AB57 Shown as Part Number Sample

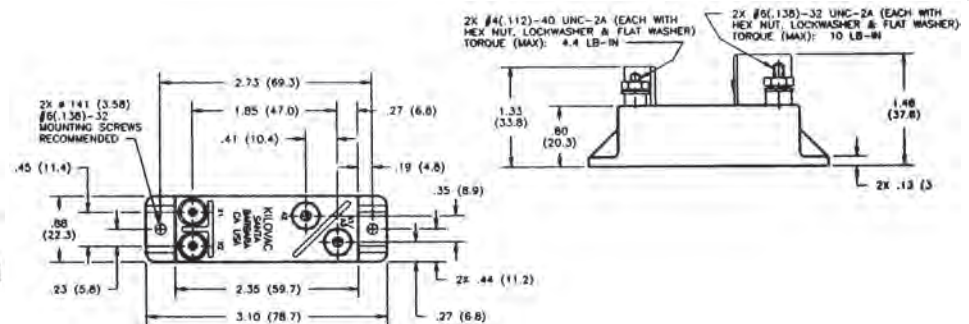

For factory-direct application assistance, dial 800-253-4560, ext. 2055, or 805-220-2055.

AP44P — 15 Amps

Product Facts

- 15 A make and break @ 270 Vdc
- 45 A carry
- 60 A overload rating
- Ideal for high voltage applications from 28 to 270 Vdc
- Latching actuator for low power consumption
- 2000 V isolation across open contacts
- Small size and weight
- Space-rated version built in accordance with customers SCD
- Meets many requirements of MIL-PRF-32085

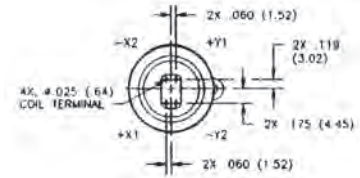
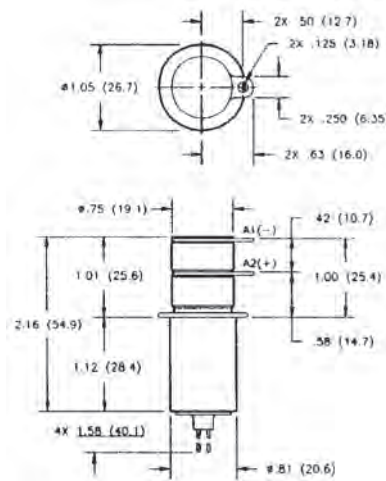

Product Specifications

Contact Arrangement —

SPST Latching

Contact Form — P

Rated Resistive Load @ 270 Vdc — 15 A*

Continuous Current Carry, Max. — 45 A

Overload @ 270 Vdc — 60 A

Contact Resistance, Max. — 10 mohm

Dielectric at Sea Level —

Coil to Case — 500 Vrms

All Other Points — 2,000 Vrms

Shock, 11ms, 1/2 Sine (Peak) — 50 g

Vibration, Sinusoidal (55-2000 Hz, Peak) — 15 g**

Operating Ambient Temperature Range — -55°C to +85°C

Load Life @ 270 Vdc, Min. — 5,000 cycles

Operate Time, Excluding Bounce, Max. — 2 ms

Release Time, Max. — N/A

Bounce Time, Max. — 3 ms

Latch/Reset Time, Including Bounce, Max. — 5 ms

Insulation Resistance @ 500 Vdc, Min. —

Initial — 100 mohm

End of Life — 50 mohm

Weight, Nominal —

43 gram (1.5 oz.)

Notes:

*The load terminals should always be connected as follows: Common Contact +; Other Contact —.

Coil Data

AP44P	28 Latching
Latch, Max.	22 Vdc
Reset, Max.	22 Vdc
Coil Resistance ($\pm 10\%$)	80 Ω

Coil resistance rated at 25°C

Ordering Information

Sample Part Number ►

Series: _____ **AP44** **P** **3** **3** **4**

Contact Form: _____
 P = SPST Latching

Coil Voltage: _____
 3 = 28 Vdc, Bus Wire

Power Terminals: _____
 3 = Solder Connection

Mounting: _____
 4 = Standard

For factory-direct application assistance, dial 800-253-4560, ext. 2055, or 805-220-2055.

PD5 Make & Break Load Switching

Product Facts

- Vacuum dielectric for power switching
- Excellent for control applications
- PCB and panel mountings
- Rugged design for the most demanding applications, including seismic shock
- Small size and weight
- Low power consumption
- No heat sinks required
- Vacuum-sealed; can operate in explosive and harsh environments
- 2000 V isolation across open contacts

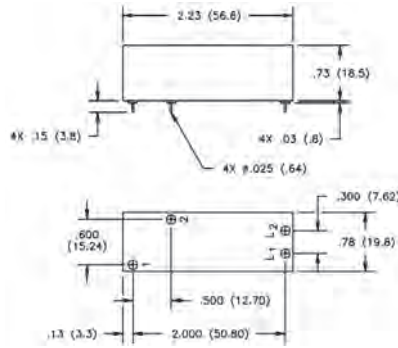

Product Specifications

- Contact Arrangement** — PD5A — SPST-NO
PD5B — SPST-NC
- Contact Form** — PD5A — A**
PD5B — B**
- Rated Resistive Load @ 320 Vdc** — 5 A
- Continuous Current Carry, Max. @ 85°C** — 15 A
- Overload @ 320 Vdc, (Make/Break)** — 20 A
- Life, (Mechanical/Rated Load)** — 500k cycles/50k cycles
- Contact Resistance, Max., End of Life** — 0.010 ohm
- Dielectric at Sea Level** — Power Terminals to Coil and All Other Points — 1,800 Vrms
- Shock, 11ms, 1/2 Sine (Peak)** — 25 g
- Vibration, Sinusoidal (55-2000 Hz, Peak)** — 5 g
- Operating Ambient Temperature Range** — -40°C to +85°C
- Operate Time, Max., Including Bounce @ 25°C** — 10 ms
- Release Time, Max., Including Bounce @ 25°C** — 10 ms
- Insulation Resistance @ 500 Vdc, Min.** — Initial/End of Life — 100 mohm/50 mohm
- Weight, Nominal** — 57 g (.125 lb)

Note:
**Contact TE for availability of other contact forms

Contact Ratings*

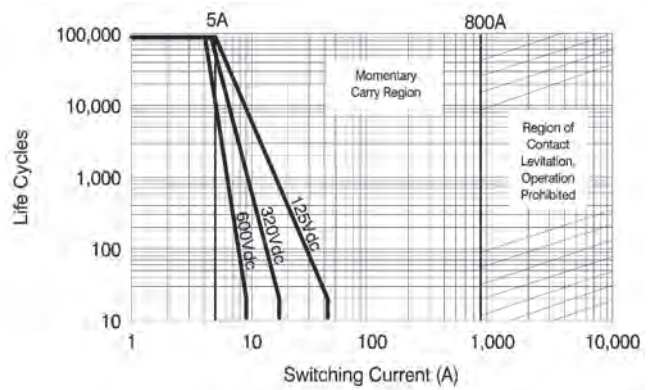

*Based on extrapolated data. Since each application is unique, user is encouraged to verify rating in actual application. The load terminals should always be connected as follows: Common Contact (A2) positive; Other Contact negative.

Coil Data

Nominal Volts DC	12 Vdc	24 Vdc	125 Vdc
Max. Coil Voltage	14 Vdc	28 Vdc	130 Vdc
Pickup, Max. @ 85°C	8 Vdc	16 Vdc	80 Vdc
Hold, Min. @ 85°C	3.3 Vdc	10 Vdc	33 Vdc
Dropout, Min. @ -40°C	.5 Vdc	1 Vdc	5 Vdc
Coil Resistance (±10%)	70 Ω	290 Ω	4700 Ω

Ratings listed are for 25°C, sea level conditions

Ordering Information

Sample Part Number ▶ PD5 A 2 3 5

Series: _____

Contact Form: _____
A = SPST-NO
B = SPST-NC
C = SPDT (PCB Only)

Coil Voltage: _____
2 = 12 Vdc, PCB Version 3 = 24 Vdc, PCB Version
5 = 125 Vdc, PCB Version
A = 12 Vdc, Panel Mount Version
B = 24 Vdc, Panel Mount Version
C = 125 Vdc, Panel Mount Version

Power Terminals: _____
3 = PCB Solder Connection
5 = Stud Terminal, Panel Mount

Mounting: _____
5 = PCB Mount 7 = Panel Mount

For factory-direct application assistance, dial 800-253-4560, ext. 2055, or 805-220-2055.

K45 Series Make & Break Load Switching — 1.5 - 2 kV Relays

K45C

Product Facts

- Small, low profile 2 kV relay
- Vacuum dielectric for power switching low current loads
- Single pole, double throw contacts
- Widely used in H.F. communication equipment
- Meets requirements of MIL-R-83725
- Low power consumption

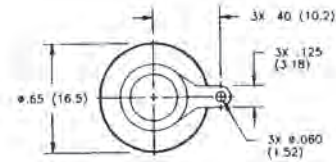
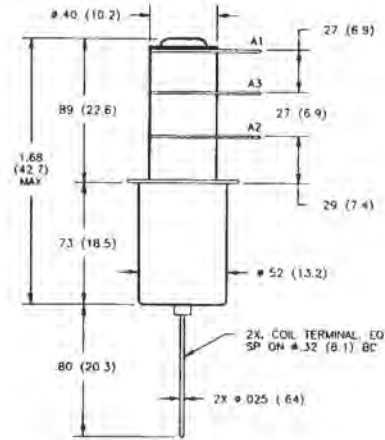

Product Specifications

Contact Arrangement — SPDT

Contact Form — C

Test Voltage, DC or 60 Hz (Peak) — 4 kV

Rated Operating Voltage (Peak) —
 DC or 60 Hz — 2 kV
 2.5 MHz — 1.8 kV
 16 MHz — 1.4 kV
 32 MHz — 1.1 kV

Continuous Carry Current, Max. —
 DC or 60 Hz — 20 A
 2.5 MHz — 16 A
 16 MHz — 10 A
 32 MHz — 6 A
 Coil Hi-Pot (Vrms, 60 Hz) — 500 A

Contact Capacitance —
 Between Open Contacts — 1.6 pF
 Open Contacts to Ground — 2 pF

Contact Resistance, Max. — 0.05 ohm

Operate Time, Max. — 10 ms

Release Time, Max. — 10 ms

Shock, 11ms, 1/2 Sine (Peak) — 30 g

Vibration —
 Peak — 10 g (10 to 2000 Hz)

Operating Ambient Temperature Range — -55°C to +125°C

Mechanical Life
 2 million cycles

Weight, Nominal — 21.26 g (0.75 oz.)

Coil Data

Volts, Nominal DC	12 V	26.5 V
Pickup, Max.	8 Vdc	16 Vdc
Hold, Max. @ 65°C	8.5 Vdc	17 Vdc
Dropout	.5-5 Vdc	1-10 Vdc
Coil Resistance ($\pm 10\%$)	230 Ω	920 Ω

Ratings listed are for 25°C, sea level conditions.

Ordering Information

Sample Part Number ▶ **K45 C 3 3 4**

Series: _____

Contact Form: _____
 C = SPDT

Coil Voltage: _____
 2 = 12 Vdc, Bus Wire
 3 = 26.5 Vdc, Bus Wire

High Voltage Connections: _____
 3 = Solder Connection

Mounting: _____
 2 = Flanged
 4 = Standard

See page 7-87 for mounting methods.

For factory-direct application assistance, dial 800-253-4560, ext. 2055, or 805-220-2055.

K41 Series Make & Break Load Switching — 5.0 kV Relays
**K41A, K41B
Product Facts**

- High current carry rating
- Vacuum dielectric for power switching low current loads
- Glazed ceramics for low current leakage
- Compact, space-saving design
- Meets requirements of MIL-R-83725
- QPL versions available, M83725/21 & M83725/22

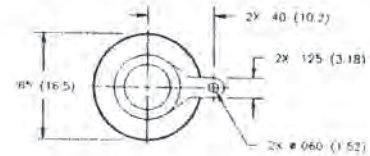
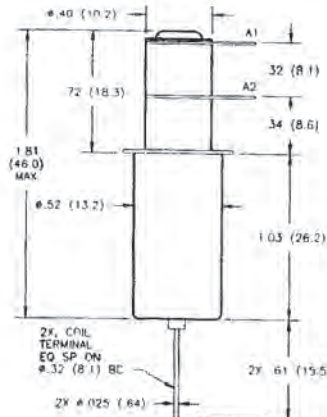
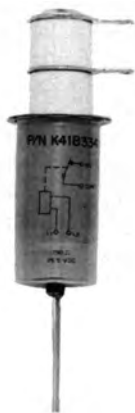
**K41C
Product Facts**

- Single pole, double throw version
- Vacuum dielectric for power switching low current loads
- RF ratings to 32 MHz
- Long life: 2 million cycles
- Meets requirements of MIL-R-83725
- QPL version available, M83725/23

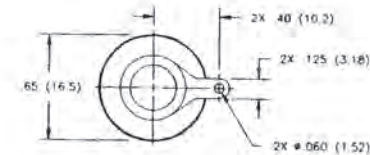
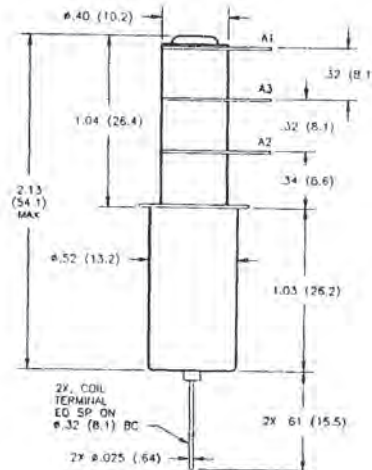
**Product Specifications for
K41A, K41B and K41C**
Contact Arrangement —

K41A — SPST-NO
K41B — SPST-NC
K41C — SPDT

Contact Form —

K41A — A
K41B — B
K41C — C

Test Voltage, DC or 60 Hz (Peak) —
6 kV

Rated Operating Voltage (Peak) —

DC or 60 Hz — 5 kV
2.5 MHz — 4.5 kV
16 MHz — 3.5 kV
32 MHz — 2.8 kV

Continuous Carry Current, Max. —

DC or 60 Hz — 30 A
2.5 MHz — 24 A
16 MHz — 16 A
32 MHz — 12 A
Coil Hi-Pot (Vrms, 60 Hz) — 500 A

Contact Capacitance —

Between Open Contacts — 1.2 pF
Open Contacts to Ground — 1.2 pF

Contact Resistance, Max. —

0.02 ohm

Operate Time, Max. — 10 ms

Release Time, Max. — 10 ms

Shock, 11ms, 1/2 Sine (Peak) —

50 g

Vibration —

Peak — 10 g (55 to 2000 Hz)

Operating Ambient Temperature

Range — -55°C to +125°C

Mechanical Life — 2 million cycles

Weight, Nominal —

28.35 g (1.0 oz.)

Coil Data

Nominal Volts DC	12 Vdc	26.5 Vdc	115 Vdc
Pickup, Max.	8 Vdc	16 Vdc	80 Vdc
Dropout	.5-5 Vdc	1-10 Vdc	5-50 Vdc
Coil Resistance (±10%)	70 Ω	290 Ω	4700 Ω

Ratings listed are for 25°C, sea level conditions

Ordering Information
Sample Part Number ▶

K41 A 3 3 4

Series:
Contact Form:

A = SPST-NO B = SPST-NC C = SPDT

Coil Voltage:

2 = 12 Vdc, Bus Wire 3 = 26.5 Vdc, Bus Wire
5 = 115 Vdc, Bus Wire 7 = 12 Vdc, Turret Terminal*
8 = 26.5 Vdc, Turret Terminal*
9 = 115 Vdc, Turret Terminal*

High Voltage Connections:

3 = Solder Connection

Mounting:

2 = Flanged

4 = Standard

For factory-direct application assistance, dial 800-253-4560, ext. 2055, or 805-220-2055.

***See page 7-87 for turret terminal dimensions and mounting methods.**

K41 Series Make & Break Load Switching — 5.0 kV Relays

K41P

Product Facts

- Fast, 6 millisecond operate time
- Vacuum dielectric for power switching low current loads
- Latching actuator for low power consumption
- Ideal for frequency agile communication systems
- Meets requirements of MIL-R-83725
- QPL version available, M83725/24

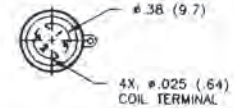
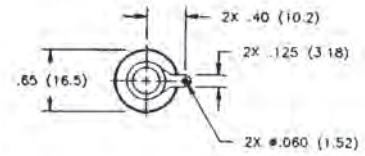
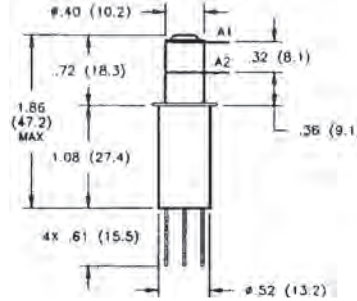

K41R

Product Facts

- Latching actuator for low power consumption
- Vacuum dielectric for power switching low current loads
- Meets requirements of MIL-R-83725
- Latching version of K41C

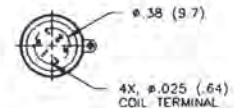
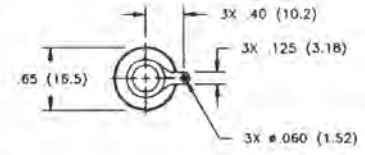
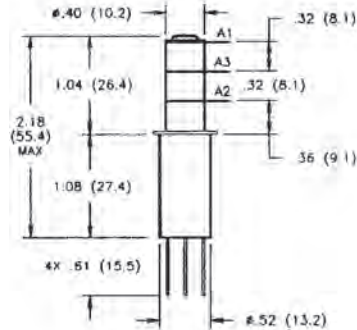

Product Specifications for K41P and K41R

Contact Arrangement —
 K41P — SPST-Latching
 K41R — SPDT-Latching

Contact Form —
 K41P — P
 K41R — R

Test Voltage, DC or 60 Hz (Peak) —
 6 kV

Rated Operating Voltage (Peak) —
 DC or 60 Hz — 5 kV
 2.5 MHz — K41P — 4.5 kV
 K41R — 4.0 kV
 16 MHz — K41P — 3.5 kV
 K41R — 3.2 kV
 32 MHz — K41P — 2.8 kV
 K41R — 2.5 kV

Continuous Carry Current, Max. —
 DC or 60 Hz — 30 A
 2.5 MHz — K41P — 20 A
 K41R — 16 A
 16 MHz — K41P — 13 A
 K41R — 10 A
 32 MHz — K41P — 10 A
 K41R — 6 A
 Coil Hi-Pot (Vrms, 60 Hz) — 500 A

Contact Capacitance —
 Between Open Contacts —
 K41P — 1.2 pF
 K41R — 1.6 pF
 Open Contacts to Ground —
 K41P — 1.2 pF
 K41R — 1.6 pF

Contact Resistance, Max. —
 0.02 ohm

Operate Time, Max. — 6 ms

Release Time, Max. — N/A

Shock, 11ms, 1/2 Sine (Peak) —
 K41P — 50 g
 K41R — 30 g

Vibration —
 Peak — 10 g (55 to 2000 Hz)

Operating Ambient Temperature Range — -55°C to +125°C

Insulation Resistance —
 Initial — 10 gigaohms

Mechanical Life — 1 million cycles

Weight, Nominal —
 28.35 g (1.0 oz.)

Coil Data

Volts, Nominal	26.5 Vdc
Reset & Latch, Max.	16 Vdc
Dropout	N/A
Coil Resistance (±10%)	80 Ω

Ratings listed are for 25°C, sea level conditions.

Ordering Information

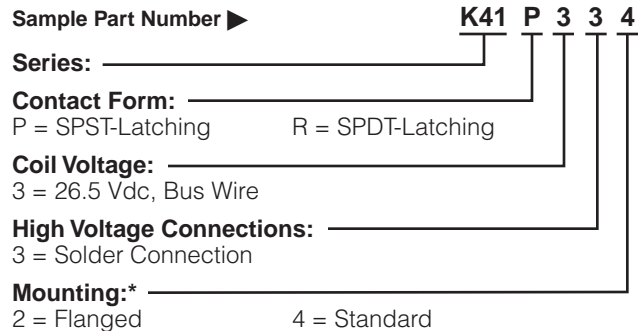

*See page 7-87 for mounting methods.

KM-17 Series Make Only Load Switching — 7.5 kV Relays

Product Facts

- Double pole, double throw contacts
- SF-6 gas-filled for ideal discharge waveform
- High voltage flying leads
- Tabs for easy mount
- Widely used in defibrillator applications

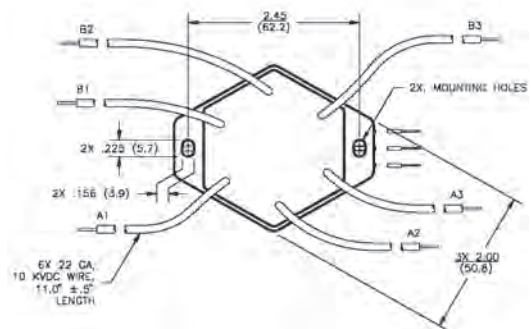
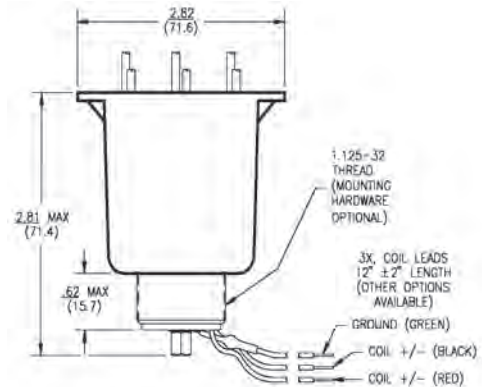

Product Specifications for KM-17

- Contact Arrangement** — DPDT
- Contact Form** — 2C
- Test Voltage, DC or 60 Hz (Peak)** — 14 kV
- Rated Operating Voltage (Peak)** — DC or 60 Hz — 7.5 kV
- Continuous Carry Current, Max.** — DC or 60 Hz — 10 A
- Coil Hi-Pot (Vrms, 60 Hz) — 500 A
- Contact Capacitance** — Between Open Contacts — N/A
- Open Contacts to Ground — N/A
- Contact Resistance, Max.** — 0.5 ohm*
- Operate Time, Max.** — 20 ms
- Release Time, Max.** — 20 ms
- Shock, 11ms, 1/2 Sine (Peak)** — 10 g

- Vibration** — Peak — 10 g (55 to 500 Hz)
- Operating Ambient Temperature Range** — -20°C to +65°C
- Insulation Resistance** — Initial — 10 gigaohms
- Mechanical Life** — 1010,000 cycle
- Weight, Nominal** — KM-17 — 311.8 g (11 oz.)

Ordering Information

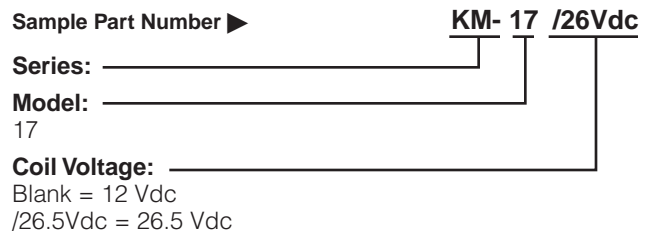

Coil Data

Nominal Volts DC	12 Vdc	26 Vdc
Pickup, Max.	8 Vdc	16 Vdc
Dropout	.5-5 Vdc	1-10 Vdc
Coil Resistance (±10%)	12 Ω	48 Ω

Ratings listed are for 25°C, sea level conditions
Coils are not for continuous duty.

For factory-direct application assistance, dial 800-253-4560, ext. 2055, or 805-220-2055.

K47 Series Make & Break Load Switching — 8 kV Relays

K47A

Product Facts for K47A

- Widely used in antenna coupler applications
- Short actuator, low profile, 8 kV relay
- Vacuum dielectric for power switching low current loads
- Normally open contacts
- Meets requirements of MIL-R-83725

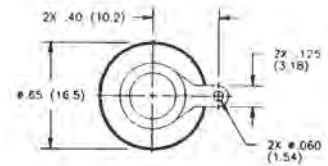
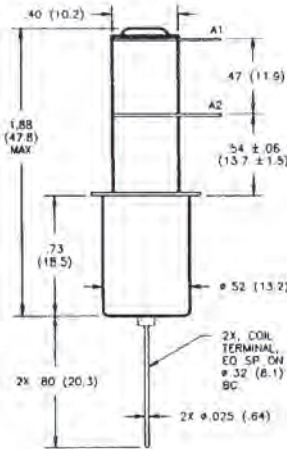

K47B

Product Facts for K47B

- Normally closed version of K47
- Vacuum dielectric for power switching low current loads
- 707 Ohm coil for low power consumption
- Meets requirements of MIL-R-83725
- QPL version available, M83725/18-003

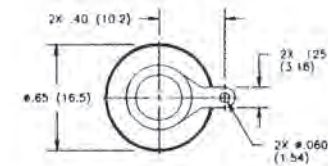
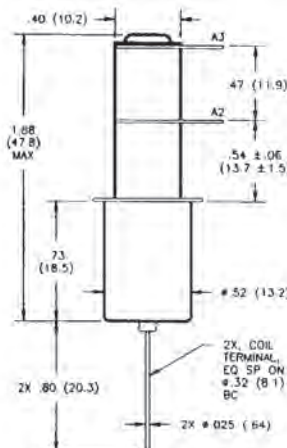

Product Specifications for K47A and K47B

Contact Arrangement —

K47A — SPST-NO
K47B — SPST-NC

Contact Form —

K47A — A
K47B — B

Test Voltage, DC or 60 Hz (Peak) — 9 kV

Rated Operating Voltage (Peak) —

DC or 60 Hz — 8 kV
2.5 MHz — 7.5 kV
16 MHz — 7 kV
32 MHz — 5 kV

Continuous Carry Current, Max. —

DC or 60 Hz — 12 A
2.5 MHz — 10 A
16 MHz — 5 A
32 MHz — 3 A
Coil Hi-Pot (Vrms, 60 Hz) — 500 A

Contact Capacitance —

Between Open Contacts — 1.2 pF
Open Contacts to Ground — 1.2 pF

For factory-direct application assistance, dial 800-253-4560, ext. 2055, or 805-220-2055.

Contact Resistance, Max. — 0.03 ohm

Operate Time, Max. — 10 ms

Release Time, Max. — 10 ms

Shock, 11ms, 1/2 Sine (Peak) — 30 g

Vibration —

Peak — 10 g (55 to 1000 Hz)

Operating Ambient Temperature Range — -55°C to +125°C

Mechanical Life — 2 million cycles

Weight, Nominal — 25.5 g (0.9 oz.)

Coil Data

Nominal Volts DC	12 Vdc	26.5 Vdc
Pickup, Max.	8 Vdc	16 Vdc
Dropout	.5-5 Vdc	1-10 Vdc
Coil Resistance (±10%)	230 Ω	707 Ω

Ratings listed are for 25°C, sea level conditions

Ordering Information

Sample Part Number ▶

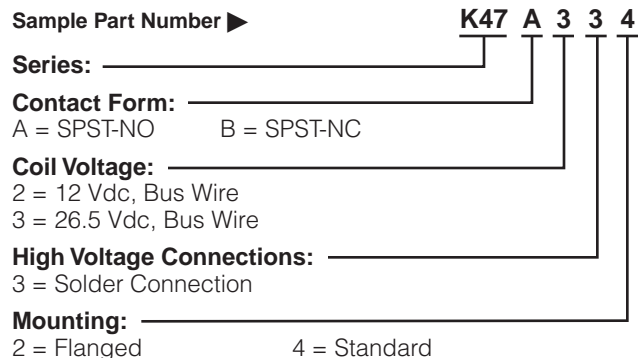

***See page 7-87 for mounting methods.**

HC Series — 8 kV Relays

HC-2
No Load Switching

HC-4
Make & Break Load Switching

Product Facts for HC-2

- Vacuum dielectric and copper contacts for high current carry rating of 25 Amps
- Not designed for power switching
- Stable, low contact resistance
- Meets requirements of MIL-R-83725

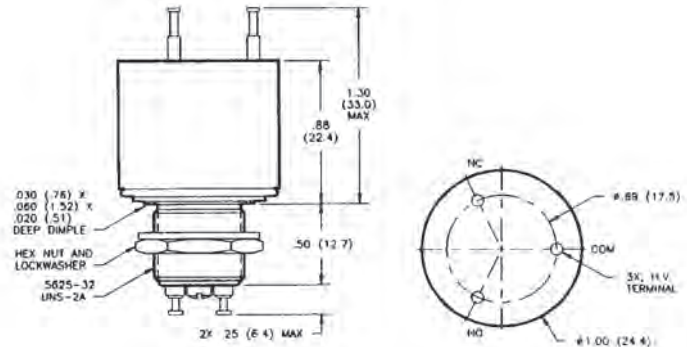

Product Facts for HC-4

- Tungsten contacts for long life in power switching applications
- Meets requirements of MIL-R-83725
- Vacuum dielectric for arc suppression when making or breaking a load

HC-6
Make Only Load Switching

Product Facts for HC-6

- Tungsten contacts for switching high in-rush loads
- SF-6 gas-filled for capacitive discharge applications
- Suitable for ESD testing applications
- Tungsten contacts for long life in power switching applications

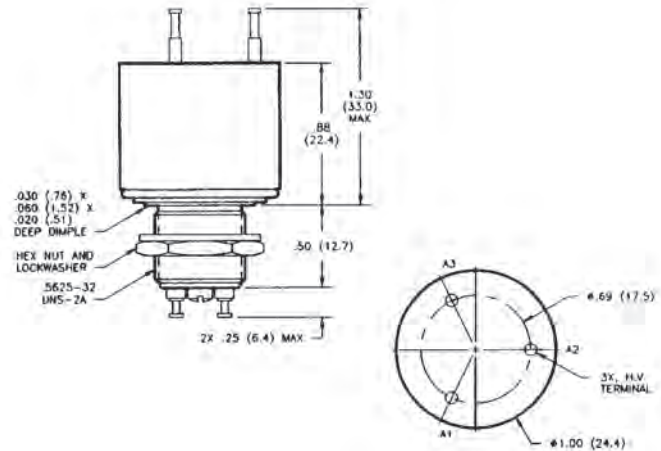

Product Specifications for HC-2, HC-4 and HC-6

Contact Arrangement — SPDT
Contact Form — C
Test Voltage, DC or 60 Hz (Peak) — 10 kV
Rated Operating Voltage (Peak) — DC or 60 Hz — 8 kV
Continuous Carry Current, Max. — DC or 60 Hz — HC-2 — 25 A RMS
 HC-4 — 15 A RMS
 HC-6 — 8 A RMS
 Coil Hi-Pot (Vrms, 60 Hz) — 500 A RMS

Contact Capacitance —
 Between Open Contacts — N/A
 Open Contacts to Ground — N/A
Contact Resistance, Max. —
 HC-2 — 0.01 ohm
 HC-4 — 0.02 ohm
 HC-6 — 0.5 ohm*

Operate Time, Max. — 6 ms
Release Time, Max. — 6 ms

Shock, 11ms, 1/2 Sine (Peak) — 50 g

Vibration —
 Peak — 10 g (55 to 2000 Hz)

Operating Ambient Temperature Range — -55°C to +125°C

Mechanical Life —
 HC-2 and HC-4 — 2 million cycles
 HC-6 — 1 million cycle

Weight, Nominal — 39.69 g (1.4 oz.)

*Contact resistance for gas-filled relays is measured at 28 Vdc, 1 Amp

For factory-direct application assistance, dial 800-253-4560, ext. 2055, or 805-220-2055.

Coil Data

Nominal Volts DC	12 Vdc	26.5 Vdc	115 Vdc
Pickup, Max.	8 Vdc	16 Vdc	80 Vdc
Dropout	.5-5 Vdc	1-10 Vdc	5-50 Vdc
Coil Resistance (±10%)	80 Ω	335 Ω	6000 Ω

Ratings listed are for 25°C, sea level conditions

Ordering Information

Sample Part Number ▶ HC- 6 /12Vdc

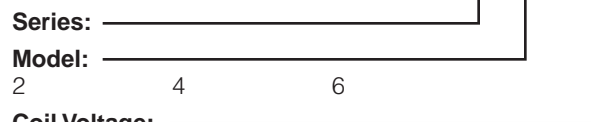

Blank = 26.5 Vdc
 /12Vdc = 12 Vdc
 /115Vdc = 115 Vdc

H-18 Series Make & Break Load Switching — 8 kV Relays

Product Facts

- Smallest DPDT high voltage relay
- Vacuum dielectric for power switching low current loads
- 8 kV rating; carries 2 Amps at 32 MHz
- Tungsten contacts for power switching low current loads
- Meets requirements of MIL-R-83725

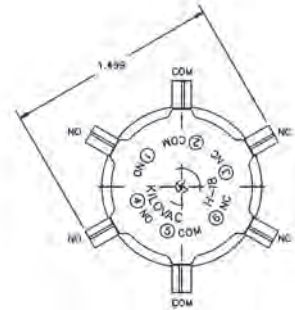
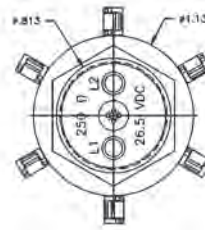
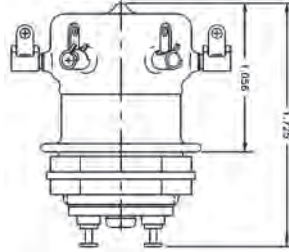

Product Specifications

Contact Arrangement — DPDT

Contact Form — 2C

Test Voltage, DC or 60 Hz (Peak) — 10 kV

Rated Operating Voltage (Peak) —
 DC or 60 Hz — 8 kV
 2.5 MHz — 5 kV
 16 MHz — 3 kV
 32 MHz — 2 kV

Continuous Carry Current, Max. —
 DC or 60 Hz — 10 A
 2.5 MHz — 7 A
 16 MHz — 3 A
 32 MHz — 2 A
 Coil Hi-Pot (Vrms, 60 Hz) — 500 A

Contact Capacitance —
 Between Open Contacts — 0.8 pF
 Open Contacts to Ground — 1.5 pF

Contact Resistance, Max. — 0.02 ohm

Operate Time, Max. — 15 ms

Release Time, Max. — 15 ms

Shock, 11ms, 1/2 Sine (Peak) — 30 g

Vibration —
 Peak — 10 g (55 to 500 Hz)

Operating Ambient Temperature Range — -55°C to +125°C

Mechanical Life — 1 million cycles

Weight, Nominal — 70.87 g (2.5 oz.)

Coil Data

Volts, Nominal DC	12 V	26.5 V	115 V
Pickup, Max.	8 Vdc	16 Vdc	80 Vdc
Dropout	5-5 Vdc	1-10 Vdc	5-50 Vdc
Coil Resistance (±10%)	60 Ω	250 Ω	3500 Ω

Ordering Information

Sample Part Number ►

Series: _____ **H-18** **/12Vdc**

Model: _____
 H-18

Coil Voltage: _____
 Blank = 26.5 Vdc
 /12Vdc = 12 Vdc
 /115Vdc = 115 Vdc

For factory-direct application assistance, dial 800-253-4560, ext. 2055, or 805-220-2055.

K81 A/B Series Make & Break Load Switching — 10 kV Relays

Product Facts

- 10 kV PC board-mount relay
- Vacuum dielectric for power switching low current loads
- Flying leads or PCB mount for high voltage connections
- Meets requirements of MIL-R-83725
- Completely sealed; suitable for test equipment
- Panel mount available for ease of mounting

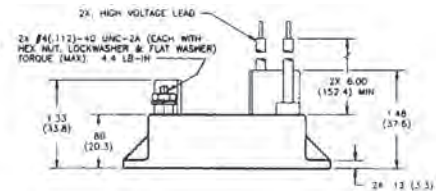
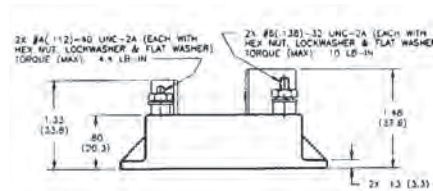
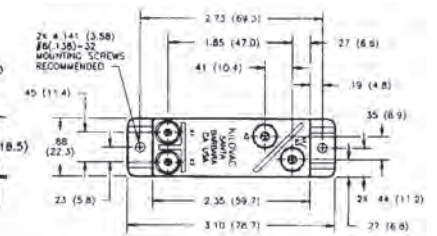
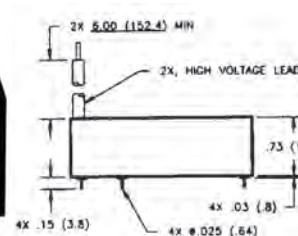
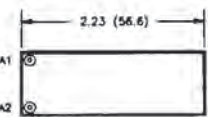
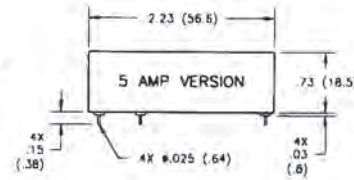
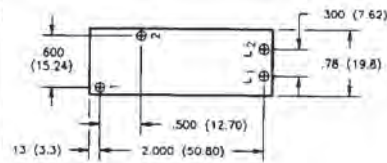

Product Specifications

Contact Arrangement —

K81A — SPST-NO
K81B — SPST-NC

Contact Form —

K81A — A
K81B — B

Test Voltage, DC or 60 Hz (Peak) — 11 kV

Rated Operating Voltage (Peak) — DC or 60 Hz — 10 kV

Continuous Carry Current, Max. — DC or 60 Hz — 5 A, 20 A or 30 A
Coil Hi-Pot (Vrms, 60 Hz) — N/A

Contact Resistance, Max. — 0.03 ohm

Operate Time, Max. — 10 ms

Release Time, Max. — 10 ms

Shock, 11ms, 1/2 Sine (Peak) — 30 g

Vibration —

Peak — 10 g (55 to 500 Hz)

Operating Ambient Temperature Range — -55°C to +85°C

Mechanical Life

— 2 million cycles

Weight, Nominal —

56.7 g (2 oz.)

Notes:

1. PC pin versions carry 5 or 20 Amps, see part number at right. Flying lead and panel versions carry 30 Amp.

*Power terminal on 20 Amp version is a larger diameter than on the 5 Amp version (.025 = 5 Amp, .064 = 20 Amp)

Coil Data

Volts, Nominal DC	12 V	26.5 V	115 V
Pickup, Max.	8 Vdc	16 Vdc	80 Vdc
Dropout	.5-5 Vdc	1-10 Vdc	5-50 Vdc
Coil Resistance (±10%)	70 Ω	290 Ω	4700 Ω

Ratings listed are for 25°C, sea level conditions

Ordering Information

Sample Part Number ►

Series: _____

Contact Form: _____

A = SPST-NO B = SPST-NC

Coil Voltage: _____

2 = 12 Vdc, PC Board 3 = 26.5 Vdc, PC Board

5 = 115 Vdc, PC Board

A = 12 Vdc, Stud Terminals, Panel Mount

B = 26.5 Vdc, Stud Terminals, Panel Mount

C = 115 Vdc, Stud Terminals, Panel Mount

High Voltage Connections: _____

A* = PCB Solder Connection — 20 Amp

3 = PCB Solder Connection — 5 Amp

4 = Flying Leads

5 = Stud Terminals

Mounting: _____

5 = PC Board

7 = Panel Mount

For factory-direct application assistance, dial 800-253-4560, ext. 2055, or 805-220-2055.

K81C Series Make & Break Load Switching — 10 kV Relays

Product Facts

- SPDT version of K81
- Vacuum dielectric for power switching low current loads
- Flying lead version will carry 10 Amps continuous current
- PCB mount version will carry 5 Amps continuous current

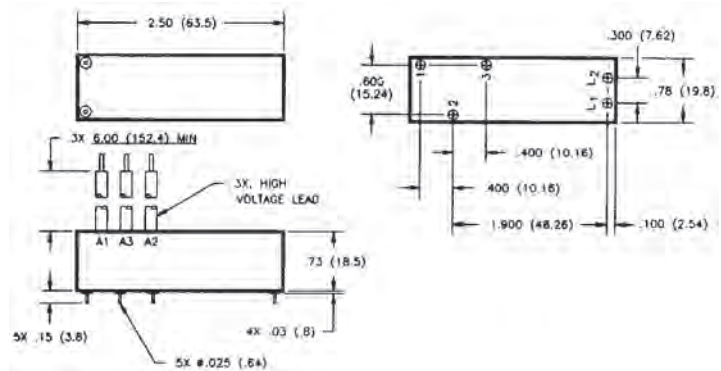
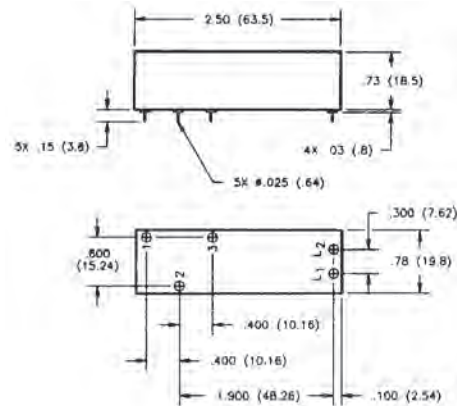

Product Specifications

- Contact Arrangement** — SPDT
Contact Form — C
Test Voltage, DC or 60 Hz (Peak) — 11 kV
Rated Operating Voltage (Peak) — DC or 60 Hz — 10 kV

- Continuous Carry Current, Max.** — DC or 60 Hz — See Note 1
 Coil Hi-Pot (Vrms, 60 Hz) — N/A
Contact Resistance, Max. — 0.05 ohm
Operate Time, Max. — 10 ms
Release Time, Max. — 10 ms

- Shock, 11ms, 1/2 Sine (Peak)** — 30 g
Vibration — Peak — 10 g (55 to 500 Hz)
Operating Ambient Temperature Range — -55°C to +85°C
Mechanical Life — 2 million cycles
Weight, Nominal — 70.87 g (2.5 oz.)

Note:
 1. 5 Amp carry for PC pin versions.
 30 Amp carry for flying lead versions.

Coil Data

Volts, Nominal DC	12 V	26.5 V	115 V
Pickup, Max.	8 Vdc	16 Vdc	80 Vdc
Dropout	.5-5 Vdc	1-10 Vdc	5-50 Vdc
Coil Resistance (±10%)	70 Ω	290 Ω	4700 Ω

Ratings listed are for 25°C, sea level conditions

Ordering Information

Sample Part Number ▶ **K81 C 3 3 5**

Series: _____

Contact Form: _____
 C = SPDT

Coil Voltage: _____
 2 = 12 Vdc, PC Board
 3 = 26.5 Vdc, PC Board
 5 = 115 Vdc, PC Board

High Voltage Connections: _____
 3 = PCB Solder Connection
 4 = Flying Leads

Mounting: _____
 5 = PC Board

For factory-direct application assistance, dial 800-253-4560, ext. 2055, or 805-220-2055.

K43 Series Make & Break Load Switching — 10 kV Relays

K43A and K43B Product Facts for K43A and K43B

- 10 kV, 25 Amps continuous current relay
- RF ratings to 32 MHz
- Vacuum dielectric for power switching low current loads
- 2 million cycle mechanical life
- QPL versions available, M83725/17 & M83725/10

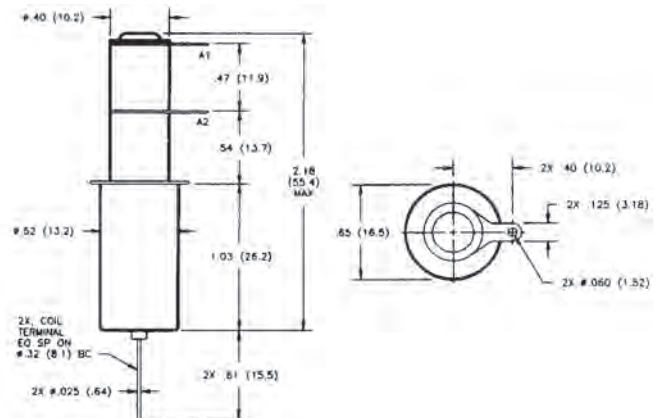

K43C Product Facts for K43C

- SPDT version of K43
- Vacuum dielectric for power switching low current loads
- Flange mounting available
- Carries 10 Amps at 32 MHz
- Meets requirements of MIL-R-83725
- QPL version available, M83725/16

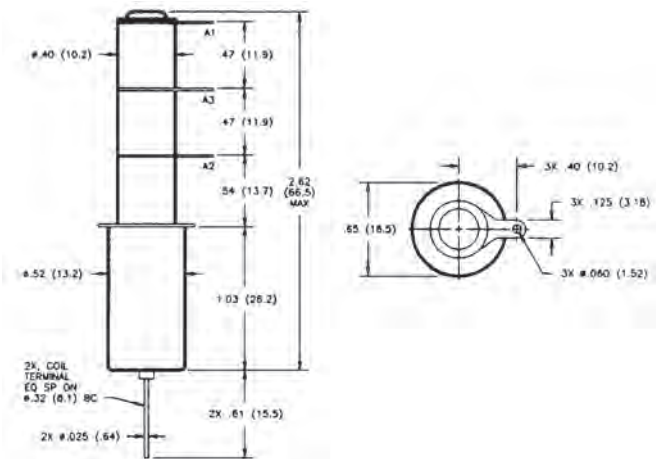

For factory-direct application assistance, dial 800-253-4560, ext. 2055, or 805-220-2055.

Product Specifications for K43A, K43B and K43C

Contact Arrangement —

- K43A — SPST-NO
- K43B — SPST-NC
- K43C — SPDT

Contact Form —

- K43A — A
- K43B — B
- K43C — C

Test Voltage, DC or 60 Hz (Peak) — 11 kV

Rated Operating Voltage (Peak) —
DC or 60 Hz — 10 kV
2.5 MHz — 7 kV
16 MHz — 6 kV
32 MHz — 4 kV

Continuous Carry Current, Max. —
DC or 60 Hz — 25 A
2.5 MHz — 20 A
16 MHz — 13 A
32 MHz — 10 A
Coil Hi-Pot (Vrms, 60 Hz) — 500 A

Contact Capacitance —
Between Open Contacts — 1.2 pF
Open Contacts to Ground — 1.2 pF

Contact Resistance, Max. — 0.02 ohm

Operate Time, Max. — 10 ms

Release Time, Max. — 10 ms

Shock, 11ms, 1/2 Sine (Peak) — 50 g

Vibration —
Peak — 10 g (55 to 2000 Hz)

Operating Ambient Temperature Range — -55°C to +125°C

Mechanical Life — 2 million cycles

Weight, Nominal — 28.35 g (1 oz.)

***See page 7-87 for turret terminal dimensions and mounting methods.**

Coil Data

Volts, Nominal DC	12 V	26.5 V	115 V
Pickup, Max.	8 Vdc	16 Vdc	80 Vdc
Dropout	.5-5 Vdc	1-10 Vdc	5-50 Vdc
Coil Resistance (±10%)	70 Ω	290 Ω	4700 Ω

Ratings listed are for 25°C, sea level conditions

Ordering Information

Sample Part Number ▶

K43 A 3 3 4

Series: _____

Contact Form: _____

A = SPST-NO B = SPST-NC C = SPDT

Coil Voltage: _____

2 = 12 Vdc, Bus Wire 3 = 26.5 Vdc, Bus Wire
5 = 115 Vdc, Bus Wire 7 = 12 Vdc, Turret Terminal*
8 = 26.5 Vdc, Turret Terminal*
9 = 115 Vdc, Turret Terminal*

High Voltage Connections: _____

3 = Solder Connection

Mounting*: _____

2 = Flanged

4 = Standard

K43 Series Make & Break Load Switching — 10 kV Relays (Continued)

**KILOVAC K43P
Make & Break Load
Switching**

Product Facts for K43P

- High power rating; 24 Amps DC continuous current carry
- Vacuum dielectric for power switching low current loads
- Low power consumption
- Fast operating: 5 millisecond operate time
- Meets requirements of MIL-R-83725

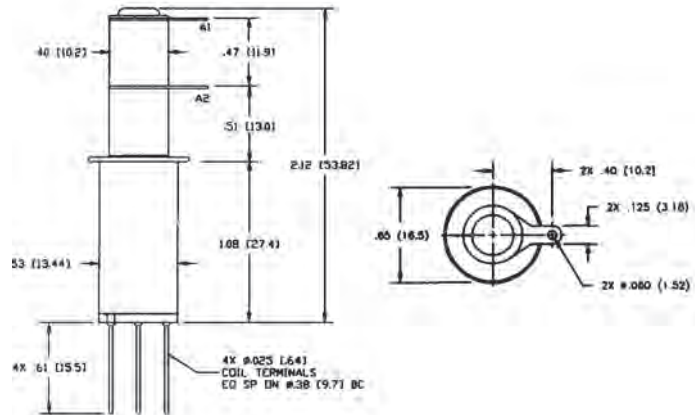

**KILOVAC K43R
Make & Break Load
Switching**

Product Facts for K43R

- Single pole, double throw contacts with latching actuator
- Vacuum dielectric for power switching low current loads
- Carries 6 Amps at 32 MHz
- Meets requirements of MIL-R-83725

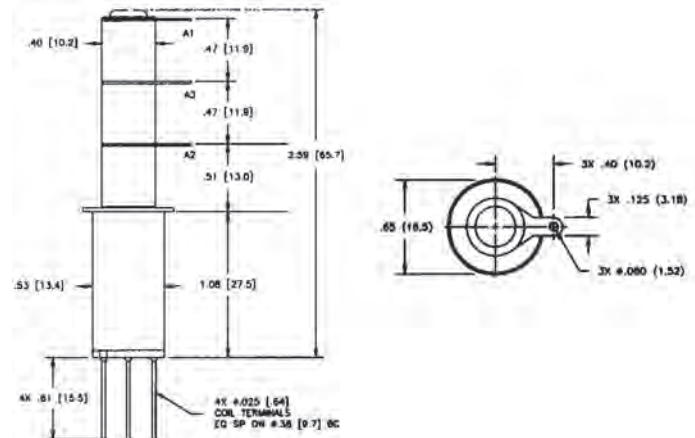

Product Specifications for K43P and K43R

Contact Arrangement —
K43P — SPST-Latching
K43R — SPDT-Latching

Contact Form —
K43P — P
K43R — R

Test Voltage, DC or 60 Hz (Peak) —
11 kV

Rated Operating Voltage (Peak) —
DC or 60 Hz — 10 kV
2.5 MHz — 7 kV
16 MHz — 6 kV
32 MHz — 4 kV

Continuous Carry Current, Max. —
DC or 60 Hz — 24 A
2.5 MHz — 16 A
16 MHz — 9 A
32 MHz — 6 A
Coil Hi-Pot (Vrms, 60 Hz) — 500 A

Contact Capacitance —
Between Open Contacts — 1.2 pF
Open Contacts to Ground — 1.2 pF

For factory-direct application assistance, dial 800-253-4560, ext. 2055, or 805-220-2055.

Contact Resistance, Max. —
0.02 ohm

Operate Time, Max. —
K43P — 5 ms
K43R — 6 ms

Release Time, Max. — N/A

Shock, 11ms, 1/2 Sine (Peak) —
30 g

Vibration —
Peak — 7 g (55 to 2000 Hz)

Operating Ambient Temperature Range — -55°C to +125°C

Mechanical Life — 1 million cycles

Weight, Nominal —
28.35 g (1 oz.)

***See page 7-87 for mounting methods.**

Coil Data

Volts, Nominal	26.5 Vdc
Latch & Reset, Max.	16 Vdc
Dropout	N/A
Coil Resistance (±10%)	80 Ω

Ratings listed are for 25°C, sea level conditions

Ordering Information

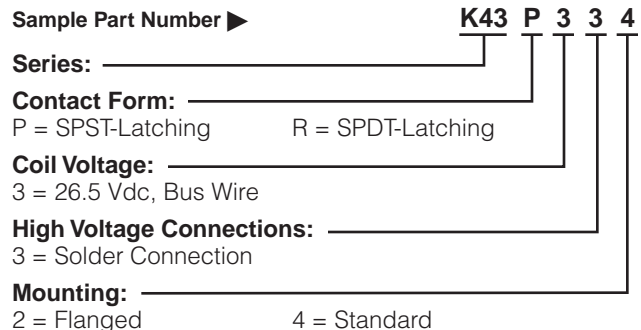

H-14/16 Series Make & Break Load Switching — 12 kV Relays

H-14

Product Facts for H-14

- Double pole, double throw contacts
- Vacuum dielectric for power switching low current loads
- 30 Amps DC continuous current rating
- Corona shield high voltage terminals available
- Meets requirements of MIL-R-83725

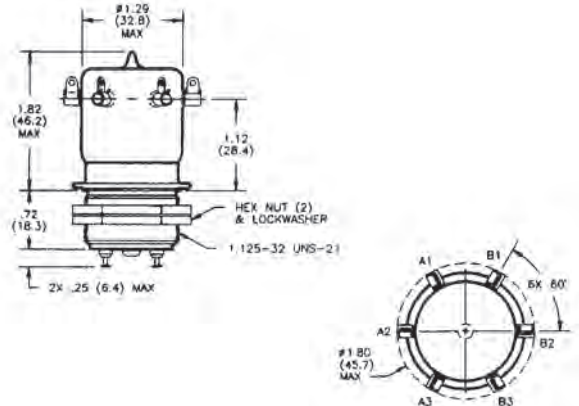

H-16

Product Facts for H-16

- 12 kV rating; isolates 5 kV at 32 MHz
- Vacuum dielectric for power switching low current loads
- Double pole, double throw contacts
- Widely used as a transmit/receive switch
- Meets requirements of MIL-R-83725

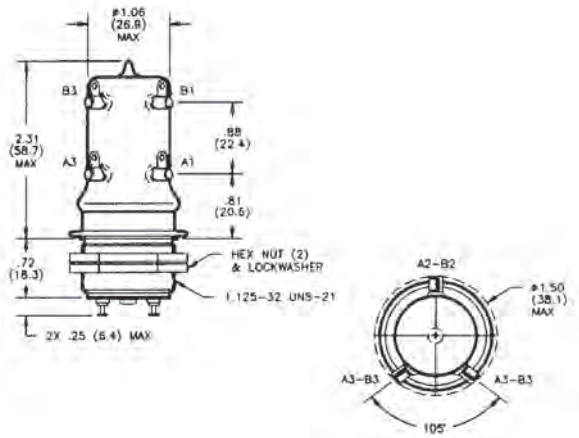

Product Specifications for H-14 and H-16

Contact Arrangement — DPDT

Contact Form — 2C

Test Voltage, DC or 60 Hz (Peak) — 15 kV

Rated Operating Voltage (Peak) —

DC or 60 Hz — 12 kV

2.5 MHz — 10 kV

16 MHz — 8 kV

32 MHz — 5 kV

Continuous Carry Current, Max. —

DC or 60 Hz — 30 A

2.5 MHz — H-14 — 15 A

H-16 — 10 A

16 MHz — H-14 — 10 A

H-16 — 6 A

32 MHz — H-14 — 8 A

H-16 — 4 A

Coil Hi-Pot (Vrms, 60 Hz) — 500 A

Contact Capacitance —

Between Open Contacts — 1 pF
Open Contacts to Ground — 2.5 pF

Contact Resistance, Max. —

H-14 — 0.015 ohm

H-16 — 0.03 ohm

Operate Time, Max. — 20 ms

Release Time, Max. — 20 ms

Shock, 11ms, 1/2 Sine (Peak) — 20 g

Vibration —

Peak — 10 g (55 to 500 Hz)

Operating Ambient Temperature Range — -55°C to +125°C

Mechanical Life (Operations x 10⁶) —

H-14 — 1 million cycles

H-16 — 500,000 cycles

Weight, Nominal —

H-14 — 226.8 g (8 oz.)

H-16 — 170.1 g (6 oz.)

Coil Data

Nominal Volts DC	12 Vdc	26.5 Vdc	115 Vdc
Pickup, Max.	8 Vdc	16 Vdc	80 Vdc
Dropout	.5-5 Vdc	1-10 Vdc	5-50 Vdc
Coil Resistance (±10%)	24 Ω	120 Ω	2000 Ω

Ratings listed are for 25°C, sea level conditions

Ordering Information

Sample Part Number ▶

Series: _____ H- 14 /12Vdc

Model: _____ 14 16

Coil Voltage: _____

Blank = 26.5 Vdc

/12Vdc = 12 Vdc

/115Vdc = 115 Vdc

For factory-direct application assistance, dial 800-253-4560, ext. 2055, or 805-220-2055.

H-8 Make & Break Load Switching — 15 kV Relays

Product Facts

- Single pole, double throw contacts
- Vacuum dielectric for power switching low current loads
- 30 Amps DC continuous current rating
- Corona shield high voltage terminals available
- Meets requirements of MIL-R-83725

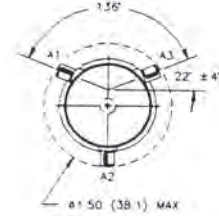
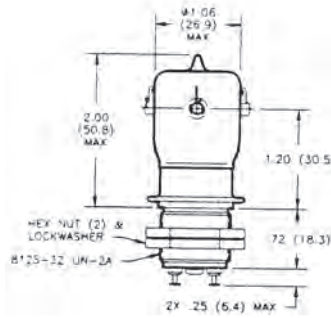

Product Specifications

Contact Arrangement — SPDT

Contact Form — C

Test Voltage, DC or 60 Hz (Peak) — 20 kV

Rated Operating Voltage (Peak) —
 DC or 60 Hz — 15 kV
 2.5 MHz — 12 kV
 16 MHz — 10 kV
 32 MHz — 5 kV

Continuous Carry Current, Max. —
 DC or 60 Hz — 15 A RMS
 2.5 MHz — 10 A RMS
 16 MHz — 6 A RMS
 32 MHz — 4 A RMS
 Coil Hi-Pot (Vrms, 60 Hz) — 500 A RMS

Contact Capacitance —
 Between Open Contacts — 1 pF
 Open Contacts to Ground — 1.5 pF

Contact Resistance, Max. — 0.015 ohm

Operate Time, Max. — 15 ms
Release Time, Max. — 15 ms

Shock, 11ms, 1/2 Sine (Peak) — 30 g

Vibration —
 Peak — 10 g (55 to 500 Hz)

Operating Temperature Range —
 -55°C to +125°C

Mechanical Life — 1 million cycles

Weight, Nominal — 85 g (3 oz.)

Coil Data

Volts, Nominal DC	12 V	26.5 V	115 V
Pickup, Max.	8 Vdc	16 Vdc	80 Vdc
Dropout	.5-5 Vdc	1-10 Vdc	5-50 Vdc
Coil Resistance (±10%)	60 Ω	265 Ω	3500 Ω

For factory-direct application assistance, dial 800-253-4560, ext. 2055, or 805-220-2055.

KC Series Make & Break Load Switching — 15 kV Relays

KC-14

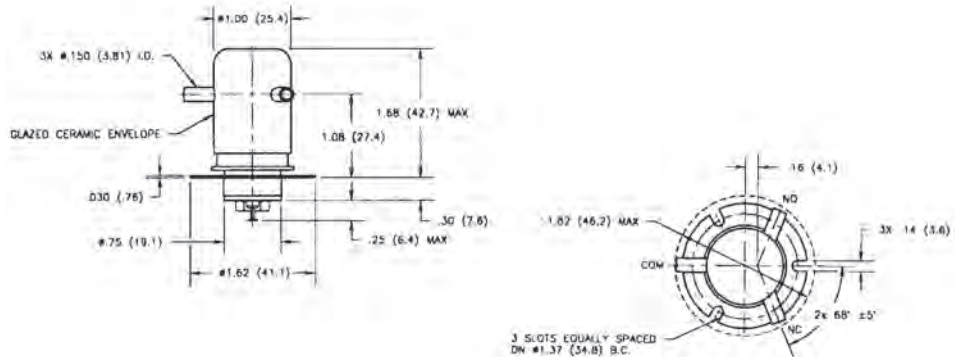

KC-18

Product Facts for KC-14 and KC-18

- Specifically designed for load switching applications
- Can power switch and isolate loads
- Replaces KILOVAC KC-8 and KC-12
- Meets requirements of MIL-R-83725

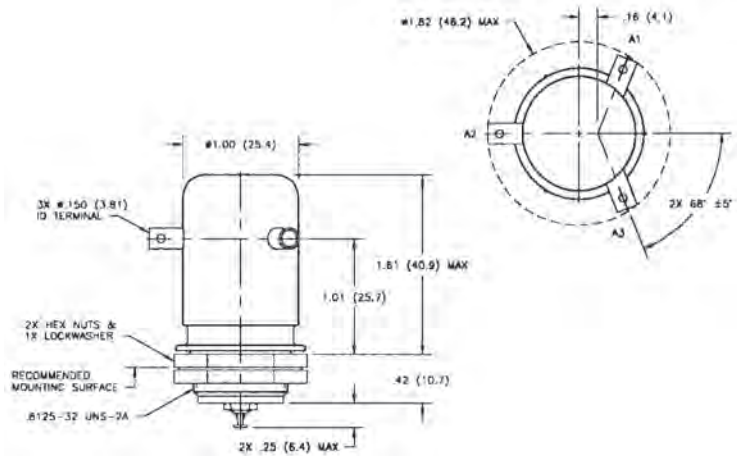

Product Specifications for KC-14 and KC-18

- Contact Arrangement** — SPDT
- Contact Form** — C
- Test Voltage, DC or 60 Hz (Peak)** — 17 kV
- Rated Operating Voltage (Peak)** — DC or 60 Hz — 15 kV
- Continuous Carry Current, Max.** — DC or 60 Hz — 30 A
- Coil Hi-Pot (Vrms, 60 Hz) — 500 A
- Contact Capacitance** — Between Open Contacts — 0.5 pF
- Open Contacts to Ground — 1 pF
- Contact Resistance, Max.** — 0.025 ohm
- Operate Time, Max.** — 15 ms
- Release Time, Max.** — 9 ms

For factory-direct application assistance, dial 800-253-4560, ext. 2055, or 805-220-2055.

- Shock, 11ms, 1/2 Sine (Peak)** — 50 g
- Vibration** — Peak — 10 g (55 to 500 Hz)
- Operating Ambient Temperature Range** — -55°C to +125°C
- Mechanical Life** — 1 million cycles
- Weight, Nominal** — 85 g (3 oz.)

***Hot Switching, Resistive Load Life**

Voltage	Current	Load Life Operations
330 Vdc	17 Amps	10,000
330 Vdc	5 Amps	100,000
5,000 Vdc	2 Amps	100,000
10,000 Vdc	1 Amps	50,000

*Ratings are for normally open contacts only. No testing has been performed on normally closed contacts.

Coil Data

Volts, Nominal DC	12 V	26.5 V	115 V
Pickup, Max.	8 Vdc	16 Vdc	80 Vdc
Dropout	.5-5 Vdc	1-10 Vdc	5-50 Vdc
Coil Resistance (±10%)	48 Ω	180 Ω	2900 Ω

Ratings listed are for 25°C, sea level conditions

Ordering Information

Sample Part Number ► **KC- 18 /12Vdc**

Series: _____

Model: _____

14 _____ 18 _____

Coil Voltage: _____

Blank = 26.5 Vdc /12Vdc = 12 Vdc /115Vdc = 115 Vdc

KC Series Make & Break Load Switching — 15 kV Relays (Continued)

KC-2
No Load Switching

Product Facts

- Vacuum dielectric for low and stable contact resistance
- Carries 50 Amps at DC; 10 Amps at 32 MHz
- Not designed for power switching

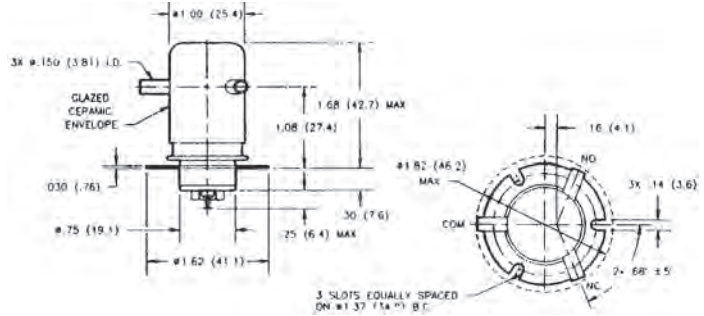

KC-8

Product Facts for KC-8

- Not recommended for new design. See KC-14 on page 7-82 for replacement.

KC-11
No Load Switching

Product Facts

- Threaded base version of KC-2
- Vacuum dielectric for low leakage current applications

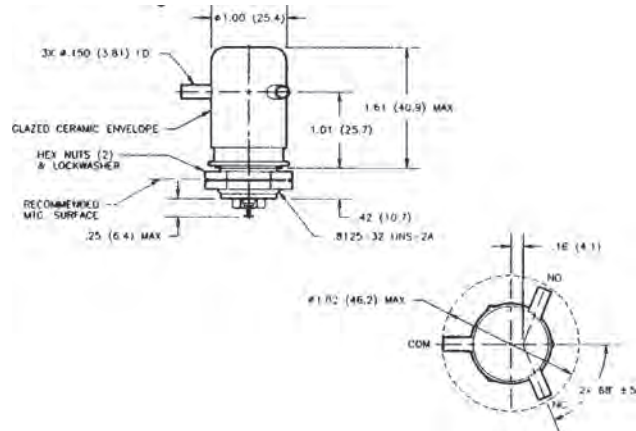

KC-12

Product Facts

- Not recommended for new design. See KC-18 on page 7-67 for replacement.
- Vacuum dielectric for power switching low current loads

Product Specifications for KC-2, KC-8, KC-11 and KC-12

- **Contact Arrangement** — SPDT
- **Contact Form** — C
- **Test Voltage, DC or 60 Hz (Peak)** — 17 kV
- **Rated Operating Voltage (Peak)** — DC or 60 Hz — 15 kV
- 2.5 MHz — KC-2 and KC-11 — 12 kV
- 16 MHz — KC-2 and KC-11 — 9 kV
- 32 MHz — KC-2 and KC-11 — 7 kV

- **Continuous Carry Current, Max.** — DC or 60 Hz — KC-2 and KC-11 — 50 A
- KC-8 and KC-12 — 30 A
- 2.5 MHz — KC-2 and KC-11 — 30 A
- 16 MHz — KC-2 and KC-11 — 17 A
- 32 MHz — KC-2 and KC-11 — 10 A
- Coil Hi-Pot (Vrms, 60 Hz) — 500 A

For factory-direct application assistance, dial 800-253-4560, ext. 2055, or 805-220-2055.

- **Contact Capacitance** — Between Open Contacts — 0.5 pF
- Open Contacts to Ground — 1 pF
- **Contact Resistance, Max.** — KC-2 and KC-11 — 0.012 ohm
- KC-8 and KC-12 — 0.025 ohm
- **Operate Time, Max.** — 15 ms
- **Release Time, Max.** — 9 ms
- **Shock, 11ms, 1/2 Sine (Peak)** — 50 g
- **Vibration** — Peak — 10 g (55 to 500 Hz)
- **Operating Ambient Temperature Range** — -55°C to +125°C
- **Mechanical Life** — 1 million cycles
- **Weight, Nominal** — 85 g (3 oz.)

Coil Data

Nominal Volts DC	12 Vdc	26.5 Vdc	115 Vdc
Pickup, Max.	8 Vdc	16 Vdc	80 Vdc
Dropout	.5-5 Vdc	1-10 Vdc	5-50 Vdc
Coil Resistance (±10%)			
KC-2 and KC-11	60 Ω	250 Ω	3500 Ω
KC-8 and KC-12	48 Ω	180 Ω	2900 Ω

Ratings listed are for 25°C, sea level conditions

Ordering Information

Sample Part Number ▶ **KC- 2 /12Vdc**

Series: _____

Model: _____

Coil Voltage: _____

Blank = 26.5 Vdc /12Vdc = 12 Vdc /115Vdc = 115 Vdc

KC Series Make Only Load Switching — 15 kV Relays (Continued)

KC-15

Product Facts

- SF-6 gas-filled for power switching on the “make”
- Long load life in capacitive discharge
- Recommended for ESD testing and safety interlock applications
- Meets requirements of MIL-R-83725

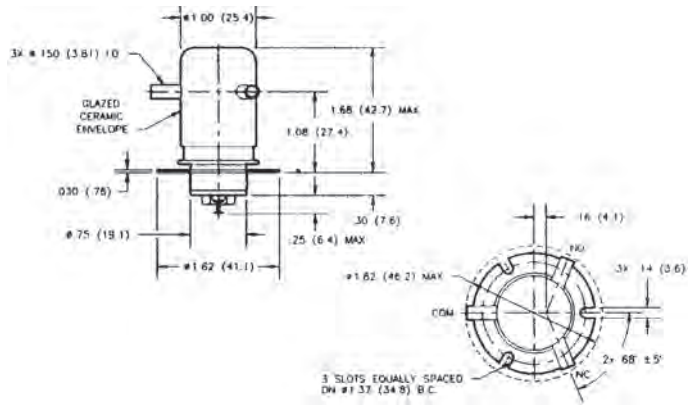

KC-16

Product Facts

- Threaded base version of KC-15
- SF-6 gas-filled for power switching on the “make”
- 15 kV rating
- Meets requirements of MIL-R-83725

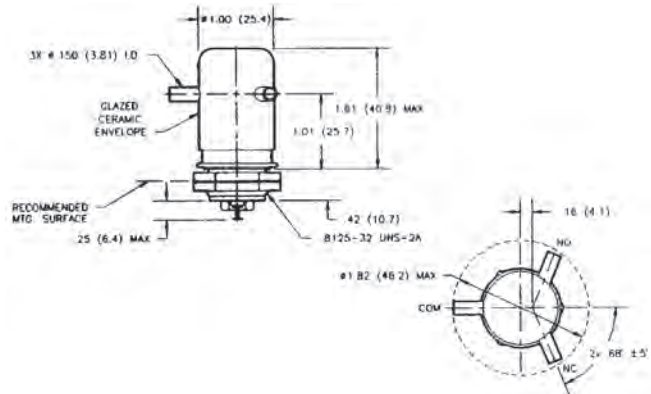

Product Specifications for KC-15 and KC-16

- Contact Arrangement** — SPDT
- Contact Form** — C
- Test Voltage, DC or 60 Hz (Peak)** — 17 kV
- Rated Operating Voltage (Peak)** — DC or 60 Hz — 15 kV
- Continuous Carry Current, Max.** — DC or 60 Hz — 12 A
Coil Hi-Pot (Vrms, 60 Hz) — 500 A
- Contact Capacitance** — Between Open Contacts — N/A
Open Contacts to Ground — N/A
- Contact Resistance, Max.** — 1.0 ohm*
- Operate Time, Max.** — 15 ms
- Release Time, Max.** — 9 ms
- Shock, 11ms, 1/2 Sine (Peak)** — 50 g
- Vibration** — Peak — 10 g (55 to 500 Hz)

- Operating Ambient Temperature Range** — -55°C to $+125^{\circ}\text{C}$
- Mechanical Life** — 1 million cycles
- Weight, Nominal** — 85 g (3 oz.)

Note:
*Contact resistance for gas-filled relays measured 28 Vdc, 1 Amp

Coil Data

Volts, Nominal DC	12 V	26.5 V	115 V
Pickup, Max.	8 Vdc	16 Vdc	80 Vdc
Dropout	.5-5 Vdc	1-10 Vdc	5-50 Vdc
Coil Resistance ($\pm 10\%$)	48 Ω	180 Ω	2900 Ω

Ratings listed are for 25°C, sea level conditions

Ordering Information

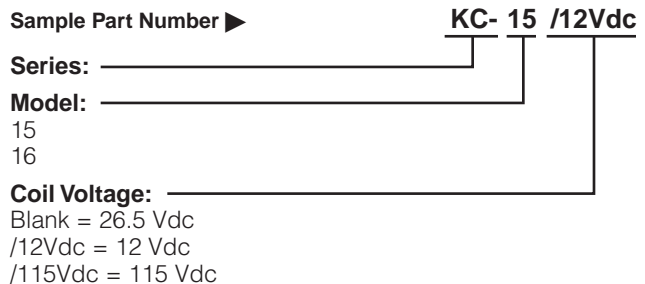

For factory-direct application assistance, dial 800-253-4560, ext. 2055, or 805-220-2055.

H-26 Series Make & Break Load Switching — 15 kV Relays

Product Facts

- Highly reliable four pole double throw relay
- Used to switch multiple loads and for polarity reversal
- Vacuum dielectric for power switching low current loads
- Meets requirements of MIL-R-83725

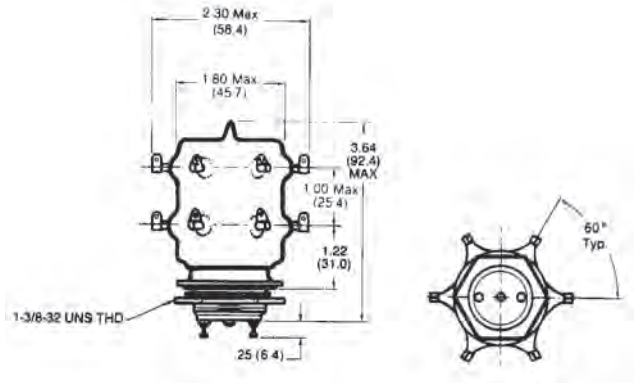

Product Specifications

Contact Arrangement — 4PDT

Contact Form — 4C

Test Voltage, DC or 60 Hz (Peak) — 17 kV

Rated Operating Voltage (Peak) —
 DC or 60 Hz — 15 kV
 2.5 MHz — 12 kV
 16 MHz — 10 kV
 32 MHz — 7 kV

Continuous Carry Current, Max. —
 DC or 60 Hz — 30 A
 2.5 MHz — 10 A
 16 MHz — 6 A
 32 MHz — 4 A
 Coil Hi-Pot (Vrms, 60 Hz) — 500 A

Contact Capacitance —

Between Open Contacts — 1 pF
 Open Contacts to Ground — 2.5 pF

Contact Resistance, Max. — 0.02 ohm

Operate Time, Max. — 30 ms

Release Time, Max. — 30 ms

Shock, 11ms, 1/2 Sine (Peak) — 30 g

Vibration —
 Peak — 10 g (55 to 500 Hz)

Operating Ambient Temperature Range — -55°C to +125°C

Mechanical Life — 100,000 cycles

Weight, Nominal — 340 g (12 oz.)

Coil Data

Volts, Nominal DC	12 V	26.5 V	115 V
Pickup, Max.	8 Vdc	16 Vdc	80 Vdc
Dropout	.5-5 Vdc	1-10 Vdc	5-50 Vdc
Coil Resistance (±10%)	N/A	130 Ω	2100 Ω

Ratings listed are for 25°C, sea level conditions

Ordering Information

Sample Part Number ►

H-26 /12Vdc

Model: _____

H-26

Coil Voltage: _____

Blank = 26.5 Vdc

/12Vdc = 12 Vdc

/115Vdc = 115 Vdc

For factory-direct application assistance, dial 800-253-4560, ext. 2055, or 805-220-2055.

H-19/17 Series Make & Break Load Switching — 20/25 kV Relays
H-19
Product Facts

- 20 kV operating voltage
- Vacuum dielectric and tungsten contacts for power switching low current loads
- Double pole, double throw contacts
- Available with corona shield connectors
- Meets requirements of MIL-R-83725

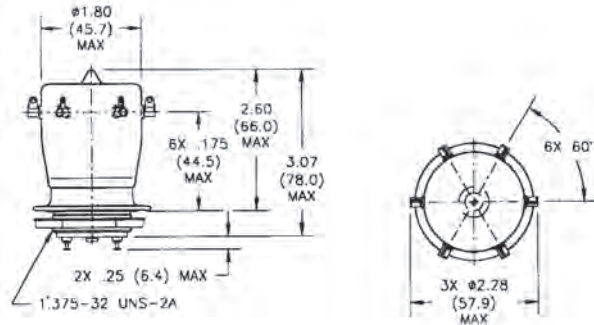
H-17
Product Facts

- Will isolate 12 kV at 32 MHz
- Tungsten contacts suitable for power switching low current loads
- Available with corona shield connectors
- Meets requirements of MIL-R-83725
- QPL version available, M83725/2

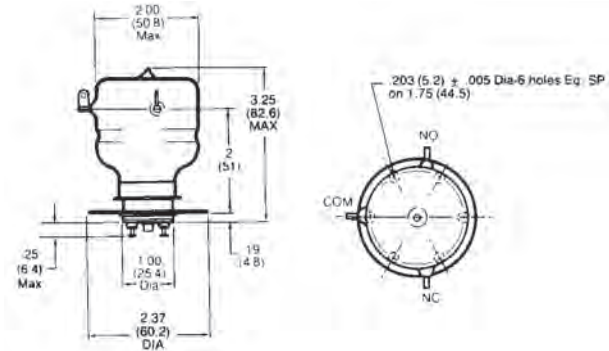
Product Specifications for H-19 and H-17
Contact Arrangement —

H-19 — DPDT
H-17 — SPDT

Contact Form —

H-19 — 2C
H-17 — C

Test Voltage, DC or 60 Hz (Peak) —

H-19 — 25 kV
H-17 — 30 kV

Rated Operating Voltage (Peak) —

DC or 60 Hz — H-19 — 20 kV
H-17 — 25 kV

2.5 MHz — H-19 — 15 kV
H-17 — 20 kV

16 MHz — H-19 — 10 kV
H-17 — 15 kV

32 MHz — H-19 — 7 kV
H-17 — 12 kV

Continuous Carry Current, Max. —

DC or 60 Hz — 30 A
2.5 MHz — H-19 — 18 A
H-17 — 16 A

16 MHz — H-19 — 9 A
H-17 — 10 A
32 MHz — H-19 — 6 A
H-17 — 8 A
Coil Hi-Pot (Vrms, 60 Hz) — 500 A

Contact Capacitance —
Between Open Contacts — 1 pF
Open Contacts to Ground — 2.5 pF

Contact Resistance, Max. —
0.015 ohm

Operate Time, Max. —

H-19 — 30 ms
H-17 — 25 ms

Release Time, Max. —

H-19 — 20 ms
H-17 — 25 ms

Shock, 11ms, 1/2 Sine (Peak) —

H-19 — 30 g
H-17 — 20 g

Vibration —

Peak — 10 g (55 to 500 Hz)

Operating Ambient Temperature Range —

-55°C to +125°C

Mechanical Life —

1 million cycles

Weight, Nominal —

H-19 — 241 g (8.5 oz.)
H-17 — 198.4 g (7 oz.)

Coil Data

Nominal Volts DC	12 Vdc	26.5 Vdc	115 Vdc
Pickup, Max.	8 Vdc	16 Vdc	80 Vdc
Dropout	.5-5 Vdc	1-10 Vdc	5-50 Vdc
Coil Resistance ($\pm 10\%$)			
H-19	48 Ω	225 Ω	2100 Ω
H-17	24 Ω	120 Ω	2900 Ω

Ratings listed are for 25°C, sea level conditions

Ordering Information
Sample Part Number ▶

Series: _____

Model: _____

H-19
H-17

Coil Voltage: _____

Blank = 26.5 Vdc
/12Vdc = 12 Vdc
/115Vdc = 115 Vdc

H- 17 /12Vdc

For factory-direct application assistance, dial 800-253-4560, ext. 2055, or 805-220-2055.

K62 Series Make & Break Load Switching — 25 kV Relays

K62A and K62B Product Facts

- 25 kV relay with flying leads for ease of installation
- Vacuum dielectric and tungsten contacts for power switching low current loads
- Meets requirements of MIL-R-83725

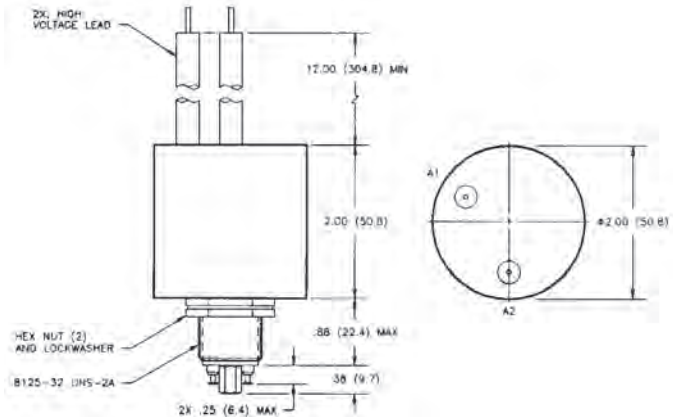

K62C Product Facts

- SPDT version of K62
- Vacuum dielectric for power switching low current loads
- Carries 18 Amps continuous current
- Meets requirements of MIL-R-83725

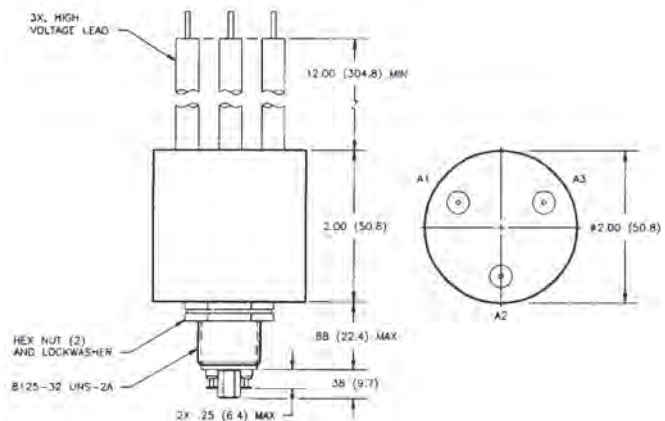

Product Specifications for K62A, K62B and K62C

Contact Arrangement —

K62A — SPST-NO
K62B — STST-NC
K62C — SPDT

Contact Form —

K62A — A
K62B — B
K62C — C

Test Voltage, DC or 60 Hz (Peak) — 30 kV

Rated Operating Voltage (Peak) — DC or 60 Hz — 25 kV

Continuous Carry Current, Max. —

DC or 60 Hz — 18 A
Coil Hi-Pot (Vrms, 60 Hz) — 500 A

Contact Resistance, Max. — 0.50 ohm

Operate Time, Max. — 15 ms

Release Time, Max. — 15 ms

Shock, 11ms, 1/2 Sine (Peak) — 20 g

Vibration — Peak — 10 g (55 to 500 Hz)

Operating Ambient Temperature Range — -55°C to +85°C

Mechanical Life — 1 million cycles

Weight, Nominal — 340 g (12 oz.)

Coil Data

Volts, Nominal DC	12 V	26.5 V	115 V
Pickup, Max.	9 Vdc	18 Vdc	90 Vdc
Dropout	.5-5 Vdc	1-10 Vdc	5-55 Vdc
Coil Resistance (±10%)	30 Ω	125 Ω	2400 Ω

Ratings listed are for 25°C, sea level conditions

Ordering Information

Sample Part Number ▶

Series: **K62 A 7 4 1**

Contact Form: A = SPST-NO B = SPST-NC C = SPDT

Coil Voltage: 7 = 12 Vdc, Turret Terminal
8 = 26.5 Vdc, Turret Terminal
9 = 115 Vdc, Turret Terminal

High Voltage Connections: 4 = Flying Leads, 12"
7 = Flying Leads, 72"
8 = Flying Leads, 36"

Mounting: 1 = Threaded

For factory-direct application assistance, dial 800-253-4560, ext. 2055, or 805-220-2055.

KC-Series No Load Switching — 25 kV Relays

KC-20

Product Facts

- Rugged, high current carry ceramic relay
- Carries 30 Amps at 32 MHz
- Copper contacts; not designed for power switching
- Meets requirements of MIL-R-83725

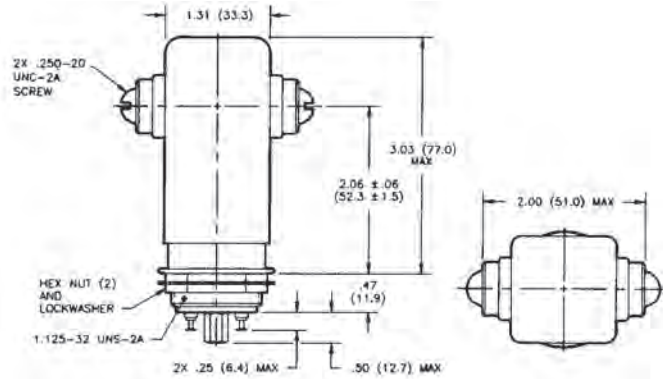

KC-30

Product Facts

- Normally closed version of KC-20
- Carries 55 Amps DC
- Vacuum dielectric for low leakage current applications

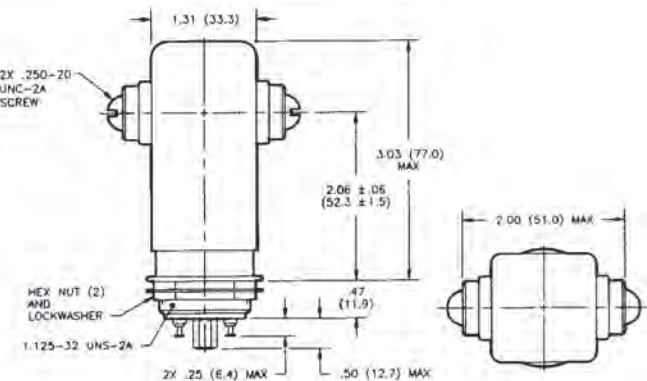

Product Specifications for KC-20 and KC-30

Contact Arrangement —

KC-20 — SPST-NO
KC-30 — SPST-NC

Contact Form —

KC-20 — X
KC-30 — Y

Test Voltage, DC or 60 Hz (Peak) —

KC-20 — 30 kV
KC-30 — 28 kV

Rated Operating Voltage (Peak) —

DC or 60 Hz — KC-20 — 28 kV
KC-30 — 25 kV

2.5 MHz — 22 kV

16 MHz — KC-20 — 12 kV
KC-30 — 10 kV

32 MHz — KC-20 — 10 kV
KC-30 — 9 kV

Continuous Carry Current, Max. —

DC or 60 Hz — KC-20 — 110 A
KC-30 — 55 A

2.5 MHz — KC-20 — 60 A
KC-30 — 30 A

16 MHz — KC-20 — 40 A
KC-30 — 20 A
32 MHz — KC-20 — 30 A
KC-30 — 15 A
Coil Hi-Pot (Vrms, 60 Hz) — 500 A

Contact Capacitance —

Between Open Contacts — 2.5 pF
Open Contacts to Ground — 2.5 pF

Contact Resistance, Max. —

KC-20 — 0.005 ohm
KC-30 — 0.01 ohm

Operate Time, Max. — 18 ms

Release Time, Max. —

KC-20 — 10 ms
KC-30 — 20 ms

Shock, 11ms, 1/2 Sine (Peak) —

30 g
Vibration —
Peak — 10 g (55 to 500 Hz)

Operating Ambient Temperature Range — -55°C to +125°C

Mechanical Life — 2 million cycles

Weight, Nominal —
340 g (12 oz.)

Coil Data

Volts, Nominal DC	12 V	26.5 V	115 V
Pickup, Max.	8 Vdc	16 Vdc	80 Vdc
Dropout	.5-5 Vdc	1-10 Vdc	5-50 Vdc
Coil Resistance (±10%)	24 Ω	120 Ω	2000 Ω

Ratings listed are for 25°C, sea level conditions

Ordering Information

Sample Part Number ▶

Series: _____

Model: _____

KC-20
KC-30

Coil Voltage: _____

Blank = 26.5 Vdc
/12Vdc = 12 Vdc
/115Vdc = 115 Vdc

KC- 20 /12Vdc

For factory-direct application assistance, dial 800-253-4560, ext. 2055, or 805-220-2055.

KC-Series — 25 kV Relays

KC-22, KC-32 Make & Break Load Switching

Product Facts for KC-22

- Tungsten contacts for power switching

Product Facts for KC-32

- Normally closed version of KC-22
- Vacuum dielectric for power switching low current loads

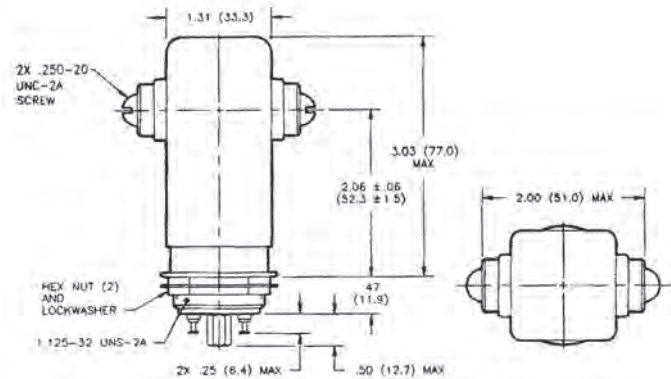

KC-28, KC-38 Make Only Load Switching

Product Facts for KC-28

- SF-6 gas-filled for capacitive discharge and “make only” applications
- Capable of switching 2000 Amps peak capacitive discharge for 400 nanoseconds

Product Facts for KC-38

- Normally closed version of KC-28
- SF-6 gas-filled for capacitive discharge and “make only” applications

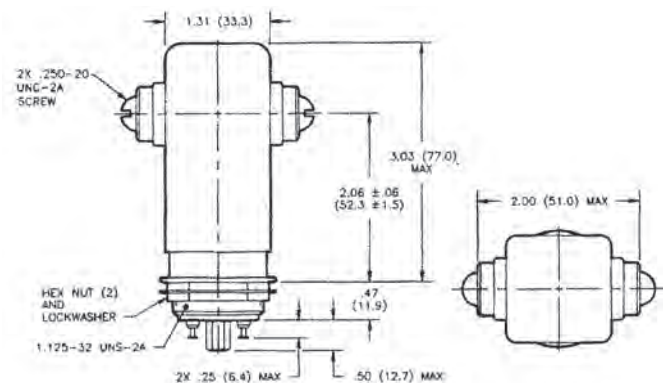

Product Specifications for KC-22, KC-32, KC-28 & KC-38

Contact Arrangement —

KC-22 and KC-28 — SPST-NO
KC-32 and KC-38 — SPST-NC

Contact Form —

KC-22 and KC-28 — X
KC-32 and KC-38 — Y

Test Voltage, DC or 60 Hz (Peak) —
28 kV

Rated Operating Voltage (Peak) —
DC or 60 Hz — 25 kV

Continuous Carry Current, Max. —

DC or 60 Hz — KC-22 — 65 A
KC-32 — 45 A
KC-28 — 30 A
KC-38 — 15 A

Coil Hi-Pot (Vrms, 60 Hz) — 500 A

Contact Capacitance —

Between Open Contacts —
KC-22 and KC-32 — 2.5 pF
Open Contacts to Ground —
KC-22 and KC-32 — 2.5 pF

Contact Resistance, Max. —

KC-22 — 0.005 ohm
KC-32 — 0.01 ohm
KC-28 — 1.0 ohm*
KC-38 — 1.0 ohm*

Operate Time, Max. — 18 ms

Release Time, Max. —

KC-22 and KC-28 — 10 ms
KC-32 and KC-38 — 20 ms

Shock, 11ms, 1/2 Sine (Peak) —
30 g

Vibration —

Peak — 10 g (55 to 500 Hz)

Operating Ambient Temperature

Range — -55°C to +125°C

Mechanical Life — 2 million cycles

Weight, Nominal — 340 g (12 oz.)

Coil Data

Volts, Nominal DC	12 V	26.5 V	115 V
Pickup, Max.	8 Vdc	16 Vdc	80 Vdc
Dropout	.5-5 Vdc	1-10 Vdc	5-50 Vdc
Coil Resistance (±10%)	24 Ω	120 Ω	2000 Ω

Ratings listed are for 25°C, sea level conditions

For factory-direct application assistance, dial 800-253-4560, ext. 2055, or 805-220-2055.

Ordering Information

Sample Part Number ►

Series: _____

Model: _____

KC-22

KC-32

KC-28

KC-38

Coil Voltage: _____

Blank = 26.5 Vdc

/12Vdc = 12 Vdc

/115Vdc = 115 Vdc

KC- 22 /12Vdc

H-23/24 Series Make & Break Load Switching — 30 kV Relay

(Not recommended for new designs)

Product Facts

- See K61 or K62 series for latest generation products
- Vacuum dielectric for power switching low current loads

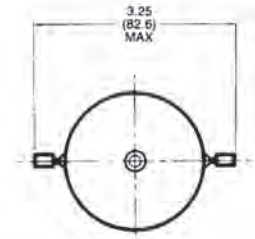
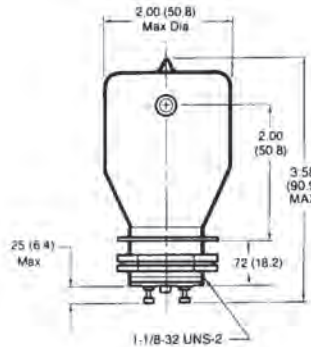

Product Specifications

Contact Arrangement —

H-23 — SPST-NC
H-24 — SPST-NO

Contact Form —

H-23 — B
H-24 — A

Test Voltage, DC or 60 Hz (Peak) —
35 kV

Rated Operating Voltage (Peak) —

DC or 60 Hz — 30 kV
2.5 MHz — 24 kV
16 MHz — 18 kV
32 MHz — 7 kV

Continuous Carry Current, Max. —

DC or 60 Hz — 30 A
2.5 MHz — 20 A
16 MHz — 12 A
32 MHz — 7 A
Coil Hi-Pot (Vrms, 60 Hz) — 500 A

Contact Capacitance —

Between Open Contacts — N/A
Open Contacts to Ground — N/A

Contact Resistance, Max. —
0.015 ohm

Operate Time, Max. — 30 ms

Release Time, Max. — 20 ms

Shock, 11ms, 1/2 Sine (Peak) —
20 g

Vibration —

Peak — 10 g (55 to 500 Hz)

Operating Ambient Temperature Range — -55°C to +125°C

Mechanical Life — 1 million cycles

Weight, Nominal — 198.4 g (7 oz.)

Coil Data

Volts, Nominal DC	12 V	26.5 V	115 V
Pickup, Max.	8 Vdc	16 Vdc	80 Vdc
Dropout	.5-5 Vdc	1-10 Vdc	5-50 Vdc
Coil Resistance (±10%)	24	120 Ω	2000 Ω

Ratings listed are for 25°C, sea level conditions

Ordering Information

Sample Part Number ►

H- 23 /12Vdc

Series: _____

Model: _____

H-23

H-24

Coil Voltage: _____

Blank = 26.5 Vdc

/12Vdc = 12 Vdc

/115Vdc = 115 Vdc

For factory-direct application assistance, dial 800-253-4560, ext. 2055, or 805-220-2055.

KP61 Series — 35 kV Relays

Product Facts

- SF-6 gas-filled relay is excellent for capacitive discharge applications
- Widely used in test equipment and medical instruments
- Fully operable in air and suitable for adverse environments
- Contact forms A, B & C
- 35 kV rating in compact, durable package
- Lower cost version of K61 series

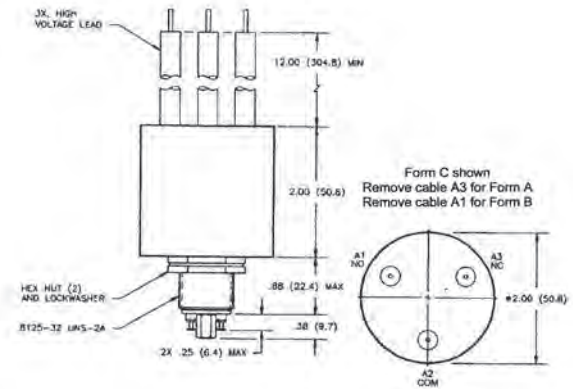

Dimensions in Inches
Tolerances Except as Noted
.JX = ± .03
.XXX = ± .010
∠X° = ± 5°
DO NOT SCALE DWG.

Product Specifications

Contact Arrangement/Form —

SPST-NO / A
SPST-NC / B
SPDT / C

Test Voltage, DC or 60 Hz (Peak) —
40 kV

Rated Operating Voltage (Peak) —
DC or 60 Hz — 35 V

Continuous Carry Current, Max. —
DC or 60 Hz — 10 A

Contact Resistance, Max. —
1.0Ω

Shock, 11ms, 1/2 Sine (Peak) —
20 g

Vibration —

Peak — 10 g (55 to 500 Hz)

Operating Ambient Temperature Range — -55°C to +85°C

Mechanical Life — 1 million cycles

Weight, Nominal — 297.7g (10.5 oz.)

Coil Data

Volts, Nominal DC	12 V	26.5 V	115 V
Pickup, Max.	30 Vdc	125 Vdc	2000 Vdc
Dropout	.5-5 Vdc	1-10 Vdc	5-50 Vdc
Coil Resistance (±10%)	24	120 Ω	2000 Ω

Ratings listed are for 25°C, sea level conditions

Ordering Information

Sample Part Number ►

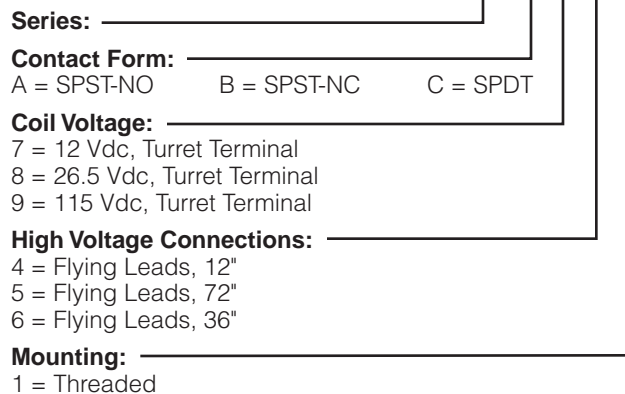

For factory-direct application assistance, dial 800-253-4560, ext. 2055, or 805-220-2055.

K60 Series Make Only Load Switching — 35 kV Relays

**K60C (35 kV)*
Product Facts**

- 35 kV rating when operated in oil or potting
- Smallest 35 kV rated relay available

*Customer must isolate high voltage terminals using suitable dielectric such as oil or potting

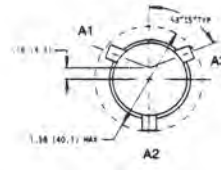
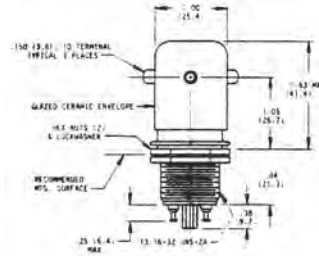

Product Specifications

- Contact Arrangement** — SPDT
- Contact Form** — C
- Test Voltage, DC or 60 Hz (Peak)** — 37 kV**
- Rated Operating Voltage (Peak)** — DC or 60 Hz — 35 kV**
- Continuous Carry Current, Max.** — DC or 60 Hz — 10 A RMS
Coil Hi-Pot (Vrms, 60 Hz) — 500 A RMS
- Contact Resistance, Max.** — N/A
- Operate Time, Max.** — 15 ms
- Release Time, Max.** — 15 ms

Shock, 11ms, 1/2 Sine (Peak) — 20 g

Vibration — Peak — 10 g (55 to 500 Hz)

Operating Ambient Temperature Range — -55°C to +85°C

Mechanical Life — 1 million cycles

Weight, Nominal — 93.6 g (3.3 oz.)

Note:
**37 kV test voltage, 35 kV operate voltage when operated in oil.

Coil Data

Volts, Nominal DC	12 V	26.5 V	115 V
Pickup, Max.	9 Vdc	18 Vdc	90 Vdc
Coil Resistance (±10%)	30 Ω	125 Ω	2400 Ω

Ratings listed are for 20°C, sea level conditions

For factory-direct application assistance, dial 800-253-4560, ext. 2055, or 805-220-2055.

K61 Series Make Only Load Switching — 35 kV Relays

**K61A and K61B
Product Facts for
K61A and K61B**

- SF-6 gas-filled relay excellent for capacitive discharge applications
- Widely used in test equipment and medical instruments
- Fully operable in air and suitable for adverse environments

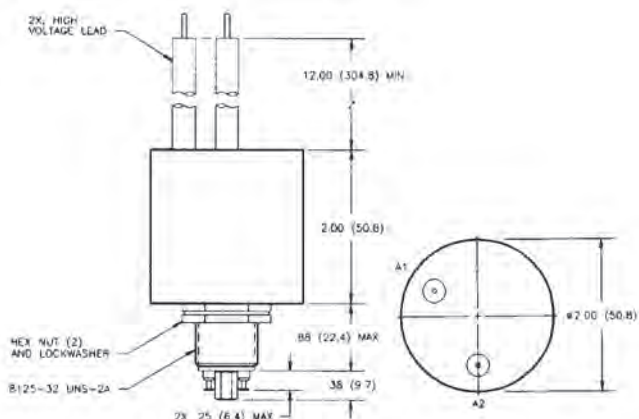

**K61C
Product Facts for K61C**

- 35 kV rating in compact, durable package
- SF-6 gas-filled relay excellent for capacitive discharge applications
- SPDT version of K61

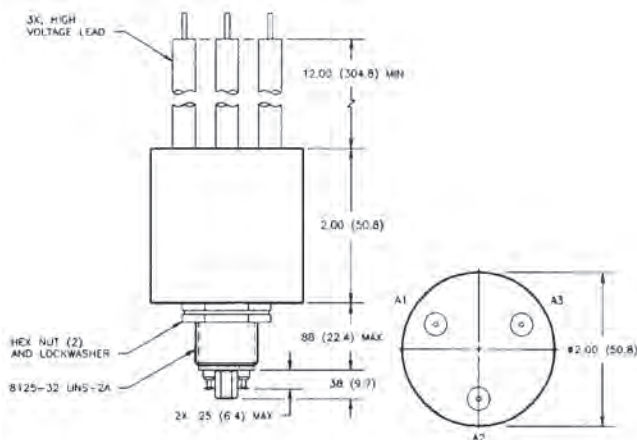

**Product Specifications for
K61A, K61B and K61C**

Contact Arrangement —

- K61A — SPST-NO
- K61B — STST-NC
- K61C — SPDT

Contact Form —

- K61A — A
- K61B — B
- K61C — C

Test Voltage, DC or 60 Hz (Peak) — 40 kV

Rated Operating Voltage (Peak) — DC or 60 Hz — 35 kV

Continuous Carry Current, Max. — DC or 60 Hz — 10 A
Coil Hi-Pot (Vrms, 60 Hz) — 500 A

Contact Resistance, Max. — 1.0 ohm*

Operate Time, Max. — 15 ms

Release Time, Max. — 15 ms

Shock, 11ms, 1/2 Sine (Peak) — 20 g

For factory-direct application assistance, dial 800-253-4560, ext. 2055, or 805-220-2055.

Vibration — Peak — 10 g (55 to 500 Hz)

Operating Ambient Temperature Range — -55°C to +85°C

Mechanical Life — 1 million cycles

Weight, Nominal — 340 g (12 oz.)

Note: *Contact resistance for gas-filled relays measured at 28 Vdc, 1 Amp

Coil Data

Volts, Nominal DC	12 V	26.5 V	115 V
Pickup, Max.	9 Vdc	18 Vdc	90 Vdc
Dropout	.5-5 Vdc	1-10 Vdc	5-50 Vdc
Coil Resistance (±10%)	30 Ω	125 Ω	2000 Ω

Ratings listed are for 25°C, sea level conditions

Ordering Information

Sample Part Number ▶ **K61 A 7 4 1**

Series: _____

Contact Form: _____
 A = SPST-NO B = SPST-NC C = SPDT

Coil Voltage: _____
 7 = 12 Vdc, Turret Terminal
 8 = 26.5 Vdc, Turret Terminal
 9 = 115 Vdc, Turret Terminal

High Voltage Connections: _____
 4 = Flying Leads, 12"
 7 = Flying Leads, 72"
 8 = Flying Leads, 36"

Mounting: _____
 1 = Threaded

K64 & H-25 Series — 50 kV Relays

K64C
Make Only Load Switching
Product Facts for K64C

- SF-6 gas-filled relay ideal for high voltage isolation or “make only” power switching
- 50 kV rating in compact package
- High voltage leads and encapsulation allow full operation in air

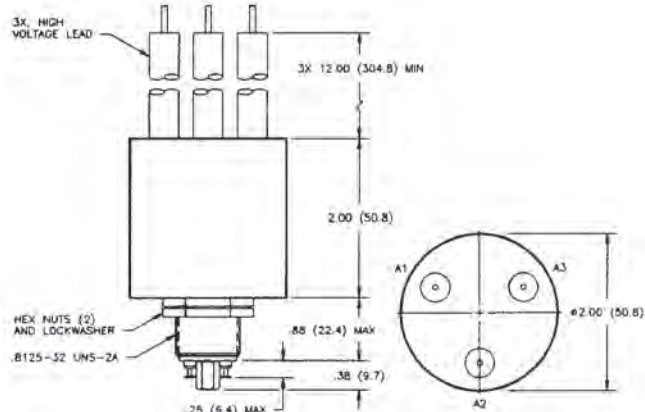

H-25
Make & Break Load Switching
Product Facts for H-25

- Vacuum relay provides low contact resistance
- Vacuum dielectric for power switching low current loads

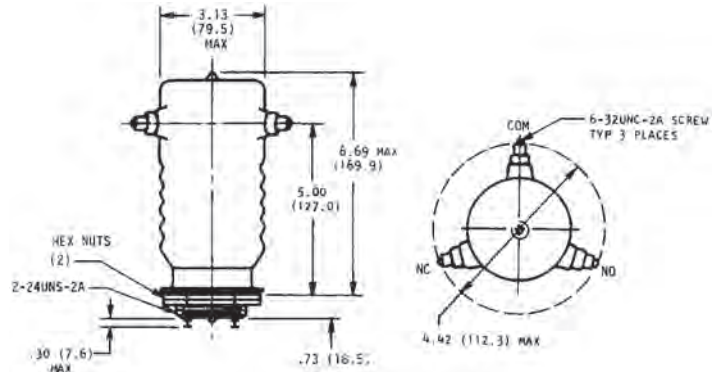

Product Specifications for K64C and H-25

- Contact Arrangement** — SPDT
- Contact Form** — C
- Test Voltage, DC or 60 Hz (Peak)** —
 K64C — 55 kV
 H-25 — 60 kV
- Rated Operating Voltage (Peak)** —
 DC or 60 Hz — 50 kV
- Continuous Carry Current, Max.** —
 DC or 60 Hz — K64C — 10 A
 H-25 — 30 A
- Coil Hi-Pot (Vrms, 60 Hz) — 500 A
- Contact Resistance, Max.** —
 K64C — 1.0 ohm*
 H-25 — 0.015 ohm
- Operate Time, Max.** —
 K64C — 15 ms
 H-25 — 60 ms
- Release Time, Max.** —
 K64C — 15 ms
 H-25 — 60 ms

Shock, 11ms, 1/2 Sine (Peak) —

- K64C — 10 g
- H-25 — 15 g
- Vibration** —
 Peak — 10 g (55 to 500 Hz)

Operating Ambient Temperature Range — -55°C to +85°C

- Mechanical Life** —
 K64C — 1 million cycles
 H-25 — 500,000 cycles

- Weight, Nominal** —
 K64C — 340 g (12 oz.)
 H-25 — 850.5 g (30 oz.)

Note:
 *Contact resistance for gas-filled relays measured at 28 Vdc, 1 Amp

Coil Data

	K64C	H-25
Nominal Volts DC	26.5 Vdc	26.5 Vdc
Pickup, Max.	18 Vdc	16 Vdc
Dropout	1-10 Vdc	1-10 Vdc
Coil Resistance (±10%)	80 Ω	120 Ω

Ratings listed are for 25°C, sea level conditions

Ordering Information

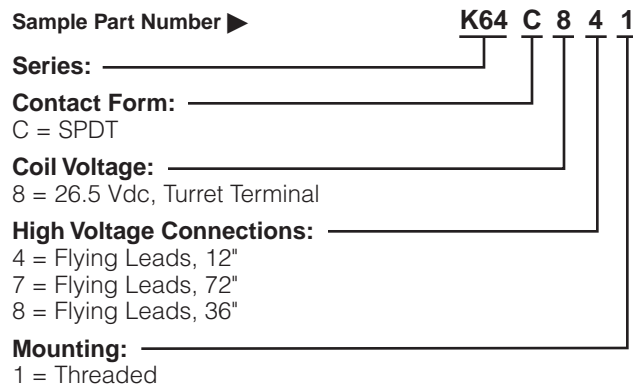

For factory-direct application assistance, dial 800-253-4560, ext. 2055, or 805-220-2055.

K70 Series Make Only Load Switching — 70 kV Relays

**K70A and K70B
Product Facts**

- New, small, compact 70 kV relay package
- SF-6 gas-filled for capacitive discharge and high voltage isolation applications
- Suitable for charging and discharging of high voltage capacitors
- Safe for use in adverse environments

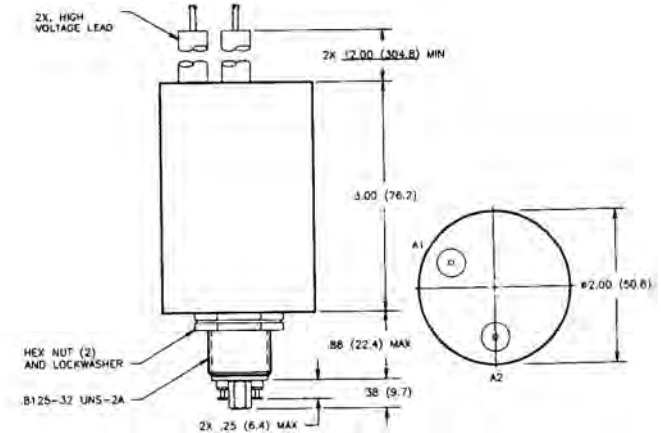

**K70C
Product Facts**

- SPDT version of K70A
- SF-6 gas-filled for capacitive discharge and high voltage isolation applications
- Suitable for charging and discharging of high voltage capacitors

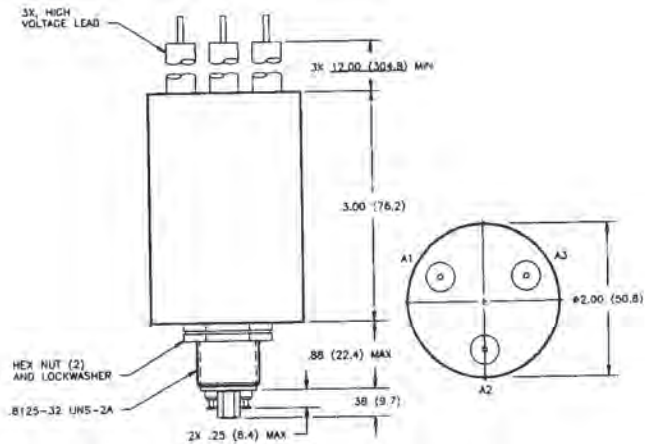

**Product Specifications for
K70A, K70B and K70C**

Contact Arrangement —

- K70A — SPST-NO
- K70B — SPST-NC
- K70C — SPDT

Contact Form —

- K70A — A
- K70B — B
- K70C — C

Test Voltage, DC or 60 Hz (Peak) —
75 kV

Rated Operating Voltage (Peak) —
DC — 70 kV

60 Hz RMS — 30 kV

Continuous Carry Current, Max. —
DC or 60 Hz — 10 A
Coil Hi-Pot (Vrms, 60 Hz) — 500 A

Contact Capacitance —

Between Open Contacts — N/A
Open Contacts to Ground — N/A

Contact Resistance, Max. —
2.0 ohm*

For factory-direct application assistance,
dial 800-253-4560, ext. 2055, or
805-220-2055.

Operate Time, Max. — 20 ms

Release Time, Max. — 15 ms

Shock, 11ms, 1/2 Sine (Peak) —
20 g

Vibration —
Peak — 10 g (55 to 500 Hz)

**Operating Ambient Temperature
Range —** 0°C to +85°C

Mechanical Life — 500,000 cycles

Weight, Nominal —
510.3 g (18 oz.)

Note:

*Contact resistance for gas-filled
relays measured at 28 Vdc, 1 Amp

Coil Data

Volts, Nominal	26.5 Vdc
Pickup, Max.	22 Vdc
Dropout	1-10 Vdc
Coil Resistance (±10%)	75 Ω

Ratings listed are for 25°C, sea level conditions

Ordering Information

Sample Part Number ► **K70 A 8 4 1**

Series: _____

Contact Form: _____
A = SPST-NO B = SPST-NC C = SPDT

Coil Voltage: _____
8 = 26.5 Vdc, Turret Terminal

High Voltage Connections: _____
4 = Flying Leads, 12"
7 = Flying Leads, 72"
8 = Flying Leads, 36"

Mounting: _____
1 = Threaded

Mounting Methods

KILOVAC “stacked ceramic” series relays can be easily mounted in any of the several ways shown below. The relay base should be mounted to a ground potential for high voltage applications. KILOVAC relays are not position sensitive and can be mounted in any orientation.

Optional Coil Turret Terminals for PD5, PD10; K41, K43 Types

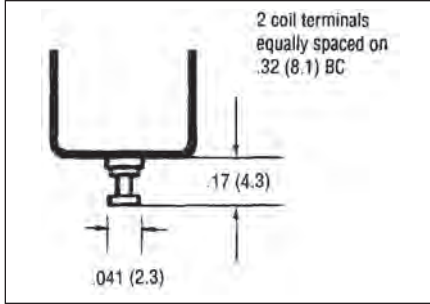

Figure 1.

Standard Flange Mounting

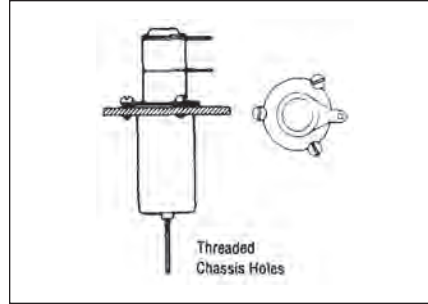

Figure 2.

Optional Flange Mounting for K44

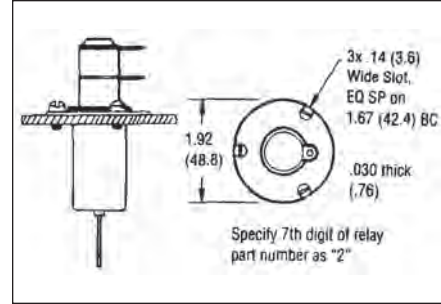

Figure 3.

Optional Flange Mounting for PD5, PD10; K40, K41, K43 and K45 types

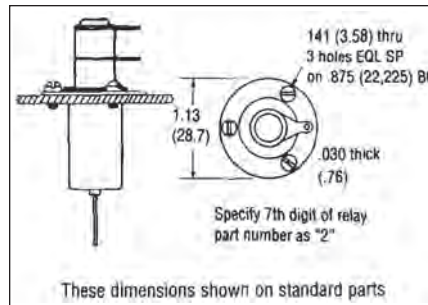

Figure 4.

Spring Clip Mounting

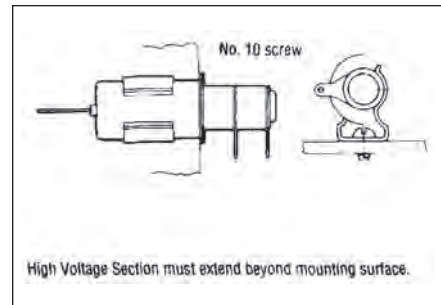

Figure 5. **Seastrom Manufacturing**
(800/447-3927 or 208/737-4300)
Part Number 4502-53-50-2N or similar.

Strap Mounting

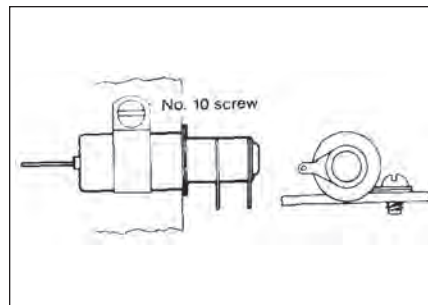

Figure 6. **Adel Fasteners**
9320010 (stainless & silicone)
9320002 (carbon steel & neoprene)

For factory-direct application assistance, dial 800-253-4560, ext. 2055, or 805-220-2055.

Special Connectors

A number of KILOVAC relays are available with special, anti-corona high voltage connectors. Refer to the chart to determine if high voltage connectors are available for your model relay. These connectors can be ordered separately, by part number, or at the same time you order your relays (for "H: relays only) by simply adding the letter "C" to the part number. For instance, if you wish to purchase an H-8 relay with special connectors, you should order an "H-8C". If you already have an H-8, you can order three Part Number 0510 connectors and install them yourself by removing the standard solder lugs and carefully installing the connectors so as not to damage the glass-to-metal seals.

Optional High Voltage Connectors

Relay Model	Connector Part Number	
H-8 H-14 H-16 H-19 H-26	0510	
H-17 H-23 H-24	1886	
EV250-1A EV250-1B EV250-2A EV250-2B EV250-8A EV250-8B	2005	
EV250-5A	2625	
KC-2, KC-8 KC-11, KC-12 KC-15, KC-16 KC-14, KC-18	6822	

Connectors for EV250-1A, 1B, 2A & 2B

TE supplies a connector with 7 leads attached. Order Part Number 2005, Part Number 1618004-1.

For factory-direct application assistance, dial 800-253-4560, ext. 2055, or 805-220-2055.

Application Notes for EV/LEV Contactors

Introduction - Product Capabilities and Typical Applications

TE KILOVAC EV and LEV contactors are designed to be the highest performance, smallest and lightest weight, sealed High Voltage contactors in the industry. With current carrying capability of up to 500A and power switching up to 200kW, they are used in a variety of industrial, marine, automotive, and commercial applications. Primarily designed to switch resistive loads, they can be used in a variety of circuit applications bearing in mind a few important considerations. This application note focuses on a few of the more common circuit configurations, and what to consider when selecting, installing and using the contactors.

1. Installation

EV/LEV contactors can be mounted in any orientation, and due to the nature of their hermetic seal and isolated enclosure, can be mounted in close proximity to other equipment. However, care must be taken with regard to the termination of the power cables to the main terminals. It is important that the main power connection lugs are mated directly to the terminal seats. Be sure that the hardware stackup is in the proper order, and that washers and other spacers are not placed between the lug and terminal seat. Extraneous connection resistance can cause considerable power dissipation and terminal heating at high current carry.

Refer to Figure 1 and Table I for the recommended hardware stackup and torque.

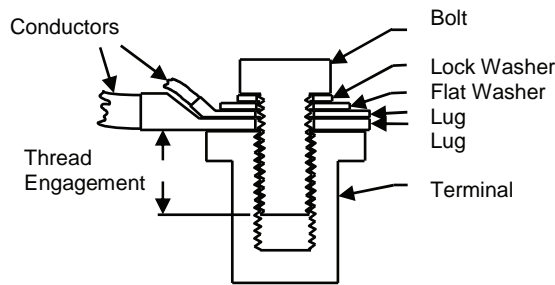

Figure 1
Main Terminal Hardware Installation

Table I

THREAD ENGAGEMENT(turns)	TORQUE
Less than 5	Use longer fastener
5 TO 7	7.9 Nm (70 in-lb) MAX
7 TO 8	9.0 Nm (80 in-lb) MAX
8 TO 11	9.0 Nm (80 in-lb) 11 Nm (100 in-lb) MAX
Mounting Feet (all)	1.7-3.3 Nm (30-35 in-lb)

Table I

Use the same guidelines and torque maximum values for stud terminal contactors as well.

2. Coils, Drive Circuits and Coil Economizing

Since the power required to close the contacts is generally much greater than the required holding power, many KILOVAC contactors can be packaged with low-profile coils that utilize either an electronic economizer (switchmode PWM), or mechanical cut-throat economizer. The economizer lets-through the higher power required for contact closure, then reduces the power for holding, greatly reducing the coil power consumption and heating. These circuits are packaged with the contactor, and in most cases include coil suppression components as well. For customers who wish to provide their own circuitry, TE can provide suggestions for driving the coils of all versions of contactors. Single coil, uneconomized products are also available in the LEV product line. These coils are designed to operate at nominal power over all specified voltage and temperature ranges without economizing circuitry. DC Coils up to 400Vdc and AC coils with integrated converters are available up to 240Vac.

3. Load Types and Power Switching Recommendations

In general, all EV/LEV contactors are designed primarily for connection and interruption of resistive loads and slightly inductive loads ($L/R < 1ms$). High currents (up to 2000A) can be interrupted in case of circuit faults, and high continuous currents upwards of 500A can be maintained through closed contacts. Some important points to consider are:

- Closing into current spikes due to uncharged filter capacitors. Capacitors should be pre-charged whenever possible to avoid excessive contact erosion and nuisance welds. Keep inrush current spikes below 650A at all times. Care should also be taken when considering other high-inrush loads such as lamps or motors.
- Large current spikes through closed contacts. Large current spikes through closed contacts in excess of 3000A can sometimes cause spot welding or contact levitation.
- Circuit inductance. Contactor break-arcs generally last as long as it takes to dissipate the stored inductive energy of the load ($t(arc) = 1.1 * L/R$).

Longer arcs due to circuit inductance can accelerate contact wear, and in extreme cases, can cause contactor failure. TE recommends that the time constant of the load be less than 1ms for safe operation and maximum life.

Contactors life is a function of the power level switched. Higher make/break currents erode contact materials faster and accelerate loss of dielectric withstanding between the open contacts. Figure 2 can be used as a guideline for estimating product life at a given load.

Application Notes for EV/LEV Contactors (Continued)

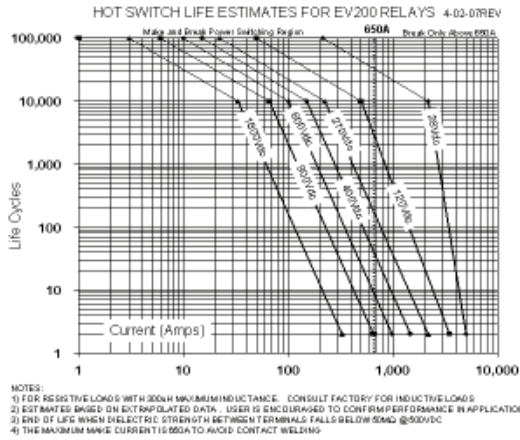

Figure 2
Life Cycles vs. Power Switched

4. Recommended Conductor Sizes for Continuous Current Carry

Many sources exist for recommending the proper conductor size for a given current carry. Many of these sources are concerned primarily with wire insulation safety issues. Cable bundling, conduit types, length of runs, etc., are all important considerations. With regard to a contactor placed in line with the conductors, it is important to make sure that the wire size is sufficient such that the contactor terminals themselves do not overheat, leading to a failure of the device. In most cases, the primary path for removal of heat from the contactor terminals is the conductors themselves. Convection to atmosphere and conduction via the base mountings play a lesser role in this type of contactor due to the nature of the construction. TE has performed basic characterization of many of the styles of contactors discussed herein, and the data is presented in Figure 3. The recommended maximum power terminal temperature for all EV/LEV contactors is 150° C continuous and 175° C for 1 hour.

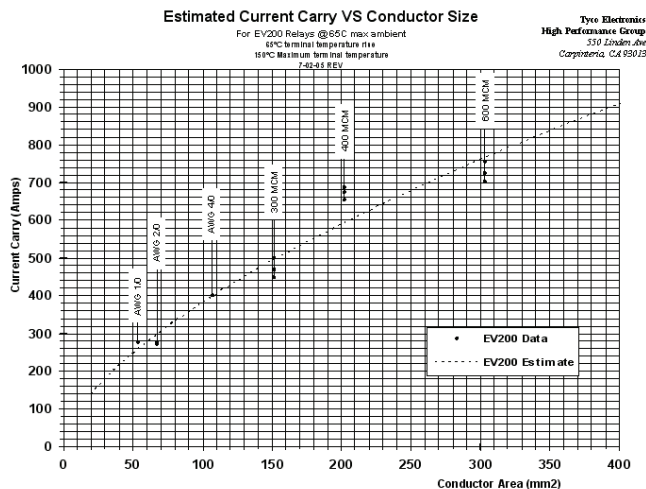

Figure 3
Recommended Conductor Sizes

For applications requiring larger conductors than can practically be installed with single 4/0 AWG cable and lugs, adapter buss extensions can be obtained from TE.

5. Auxiliary Circuits

Auxiliary contacts are available on most models. Configurations available are: SPST-NO, SPST-NC and SPDT. Auxiliary contacts are rated at 125Vac/ 1A or 30Vdc/3A. Contacts with gold plating for low level loads are also available. For circuit voltage below 10V/0.1A, gold contacts are recommended.

The auxiliary contact actuating method will indicate the true position of the main contacts. The auxiliary contact actuation is directly coupled to the main contact moving bridge, and will not indicate "open" unless both contact gaps of the double-make, Form X contact are fully disconnected. Keep in mind that the auxiliary contact is mainly a status indication, and should not be used to directly power other loads such as a relay coil or high power lamp load.

6. Environmental Considerations

All KILOVAC contactors are characterized for operation in thermal, vibration, moisture and fluid environments. Consult the appropriate data sheet for limits concerning shock, vibration, temperature range and altitude limits. In some cases, there may be variations in limits with regard to "specified operation" or "survival only".

7. Custom Configurations

Most parts can be ordered with a variety of combinations of main terminal and coil configurations, auxiliary contacts, interface connectors, coil voltages, etc. If you have a requirement for a particular configuration not shown on the data sheet, consult the factory for information regarding custom configurations.

8. Summary

This Application Note is meant to address some of the more common questions regarding the use of EV/LEV contactors. In all cases, please refer to the applicable product data sheet for specific information. Also, Product Application Engineers are available to answer questions regarding these products by calling 800-253-4560 x2055, or 805-220-2055.

Application Notes for MAP/CAP Contactors

Introduction - Product Capabilities And Typical Applications

TE KILOVAC MAP/CAP contactors are designed to be the highest performance, smallest and lightest weight, sealed High Voltage contactors in the industry. With current carrying capability of up to 500A and power switching up to 200kW, they are used in a variety of commercial aerospace and military applications. Primarily designed to switch resistive loads, they can be used in a variety of circuit applications bearing in mind a few important considerations. This application note focuses on a few of the more common circuit configurations, and what to consider when selecting, installing and using the contactors.

1. Installation

TE KILOVAC MAP/CAP contactors can be mounted in any orientation, and due to the nature of their hermetic seal and isolated enclosure, can be mounted in close proximity to other equipment. However, care must be taken with regard to the termination of the power cables to the main terminals. It is important that the main power connection lugs are mated directly to the terminal seats. Be sure that the hardware stackup is in the proper order, and that washers and other spacers are not placed between the lug and terminal seat. Extraneous connection resistance can cause considerable power dissipation and terminal heating at high current carry. Refer to Figure 1 and Table I for the recommended hardware stackup and torque.

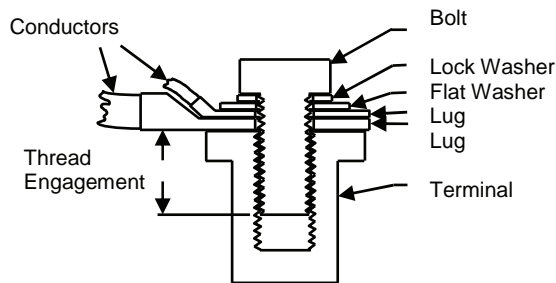

Figure 1
Main Terminal Hardware Installation

THREAD ENGAGEMENT(turns)	TORQUE
Less than 5	Use longer fastener
5 TO 7	7.9 Nm (70 in-lb) MAX
7 TO 8	9.0 Nm (80 in-lb) MAX
8 TO 11	9.0 Nm (80 in-lb) 11 Nm (100 in-lb) MAX
Mounting Feet (all)	1.7-3.3 Nm (30-35 in-lb)

Table I

Use the same guidelines and torque maximum values for stud terminal contactors as well.

2. Coils, Drive Circuits and Coil Economizing

Since the power required to close the contacts is generally much greater than the required holding power, many contactors can be packaged with low-profile coils that utilize either an electronic economizer (switchmode PWM, electronic cut-throat), or mechanical cutthroat economizer. The economizer lets-through the higher power required for contact closure, then reduces the power for holding, greatly reducing the coil power consumption and heating. These circuits are packaged with the contactor, and in most cases include coil suppression components as well. For customers who wish to provide their own circuitry, TE can provide suggestions for driving the coils of all versions of contactors. Four types of actuators are typically used:

- a. Single Coil requiring customer economizer circuit
- b. Single Coil with supplied electronic economizer
- c. Dual Coil with supplied mechanical "cut-throat" economizer
- d. Dual Coil with supplied electrical "cut-throat" economizer

The advantages of each type of coil circuit are shown in Table II.

Type	Advantage
Electronic PWM	Operates over widest voltage range
Electronic CT	Simple, Robust, EMC Compliant
Mechanical CT	Simple, robust, fastest operate time
Single Coil - (customer economized)	Flexibility, lower initial cost

Table II
Coil Configurations

3. Load Types and Power Switching Recommendations

In general, all MAP/CAP contactors are designed primarily for connection and interruption of resistive loads and slightly inductive loads ($L/R < 1\text{ms}$). High currents (up to 2000A) can be interrupted in case of circuit faults, and high continuous currents upwards of 500A can be maintained through closed contacts. Some important points to consider are:

- a. Closing into current spikes due to uncharged filter capacitors. Capacitors should be pre-charged whenever possible to avoid excessive contact erosion and nuisance welds. Keep inrush current spikes below 650A at all times. Care should also be taken when considering other high-inrush loads such as lamps or motors.

Application Notes for MAP/CAP Contactors (Continued)

- b.** Large current spikes through closed contacts. Large current spikes through closed contacts in excess of 3000A can sometimes cause spot welding or contact levitation. Consult with the factory if your application requires passing large current pulses. Many contactors can be ordered with "Dual Contact" arrangements (Arcing contacts of harder material in parallel with high current carry material).
- c.** Circuit inductance. Contactor break-arcs generally last as long as it takes to dissipate the stored inductive energy of the load ($t(\text{arc}) = 1.1 \cdot L/R$).

Longer arcs due to circuit inductance can accelerate contact wear, and in extreme cases, can cause contactor failure. TE recommends that the time constant of the load be less than 1ms for safe operation and maximum life.

Contactor life is a function of the power level switched. Higher make/break currents erode contact materials faster and accelerate loss of dielectric withstanding between the open contacts. Figure 2 can be used as a guideline for estimating product life at a given load.

Longer arcs due to circuit inductance can accelerate contact wear, and in extreme cases, can cause contactor failure. TE recommends that the time constant of the load be less than 1ms for safe operation and maximum life.

Contactor life is a function of the power level switched. Higher make/break currents erode contact materials faster and accelerate loss of dielectric withstanding between the open contacts. Figure 2 can be used as a guideline for estimating product life at a given load.

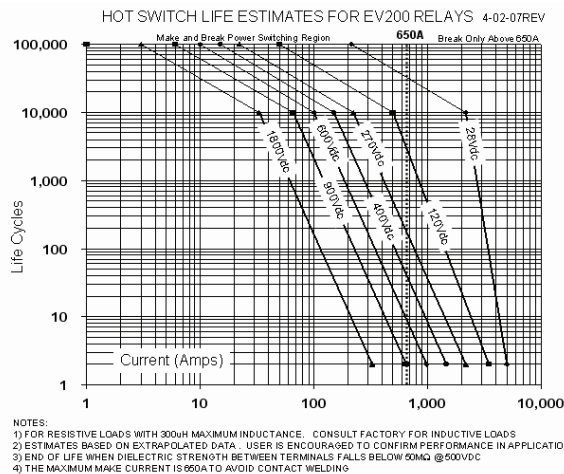

Figure 2
Life Cycle vs. Power Switched

4. Recommended Conductor Sizes for Continuous Current Carry

Many sources exist for recommending the proper conductor size for a given current carry. Many of these sources are concerned primarily with wire insulation safety issues. Cable bundling, conduit types, length of runs, etc., are all important considerations. With regard to a contactor placed in line with the conductors, it is important to make sure that the wire size is sufficient such that the contactor terminals themselves do not overheat, leading to a failure of the device. In most cases, the primary path for removal of heat from the contactor terminals is the conductors themselves. Convection to atmosphere and conduction via the base mountings play a lesser role in this type of contactor due to the nature of the construction. TE has performed basic characterization of many of the styles of contactors discussed herein, and the data is presented in Figure 3.

The recommended maximum power terminal temperature for all MAP/CAP contactors is 150° C continuous and 175° C for 1 hour.

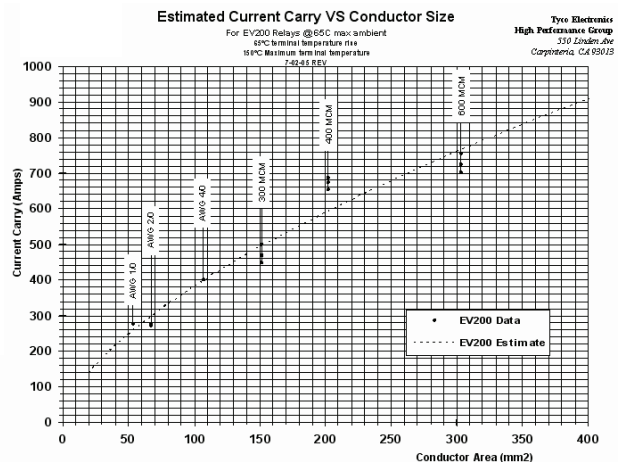

Figure 3
Recommended Conductor Sizes

For applications requiring larger conductors than can practically be installed with single 4/0 AWG cable and lugs, adapter buss extensions can be obtained from TE.

5. Auxiliary Circuits

Auxiliary contacts are available on most models. Configurations available are: SPST-NO, SPST-NC and SPDT. Auxiliary contacts are rated at 125Vac/ 1A or 30Vdc/3A. Contacts with gold plating for low level loads are also available. For circuit voltage below 10V/0.1A, gold contacts are recommended. The auxiliary contact actuating method will indicate the true position of the main contacts. The auxiliary contact actuation is directly coupled to the main contact moving bridge, and will not indicate "open" unless both contact gaps of the double-make, Form X contact are fully disconnected. Keep in mind that the auxiliary contact is mainly a status indication, and should not be used to directly power other loads such as a relay coil or high power lamp load.

Application Notes for MAP/CAP Contactors (Continued)

6. Environmental Considerations

All TE KILOVAC contactors are characterized for operation in thermal, vibration, moisture and fluid environments. Consult the appropriate data sheet for limits concerning shock, vibration, temperature range and altitude limits. In some cases, there may be variations in limits with regard to "specified operation" or "survival only".

7. Custom Configurations

Most parts can be ordered with a variety of combinations of main terminal and coil configurations, auxiliary contacts, interface connectors, coil voltages, etc. If you have a requirement for a particular configuration not shown on the data sheet, consult the factory for information regarding custom configurations.

8. Summary

This Application Note is meant to address some of the more common questions regarding the use of MAP/CAP contactors. In all cases, please refer to the applicable product data sheet for specific information.

Also, Product Application Engineers are available to answer questions regarding these products by calling 800-253-4560 x2055, or 805-220-2055.

Application Notes on Coil Power Economizing using PWM Circuits

Introduction - Reducing Coil Power Dissipation through the use of PWM Circuits

The coil power of most TE KILOVAC Relays and Contactors can be reduced after Pickup by using several economizing schemes. One of the most popular methods used in many of our standard products, and one that is suitable for implementation by customers, is the Pulse Width Modulated (PWM) coil driver.

In the circuit shown, the "Fast Dropout" (FDO) and PWM driver are energized simultaneously for a sufficient time to allow the contacts to fully close. The PWM driver is then modulated such that the stored coil energy is utilized during the PWM driver "OFF" time to circulate holding current through the FDO driver and freewheeling diode. Since the holding current is much lower than the current required for pickup, the holding power for the contacts is greatly reduced.

1. Typical PWM Coil Drive Circuit

Figure 1 shows a typical PWM coil drive/economizer circuit.

The Fast Dropout circuit allows for the switching in/out of the "free-wheeling" diode. When power is removed, the FDO and PWM drivers will turn off, causing the stored energy of the coil to be rapidly dissipated in the body diodes. This minimizes the decay time of the coil current and facilitates a fast opening of the relay contacts.

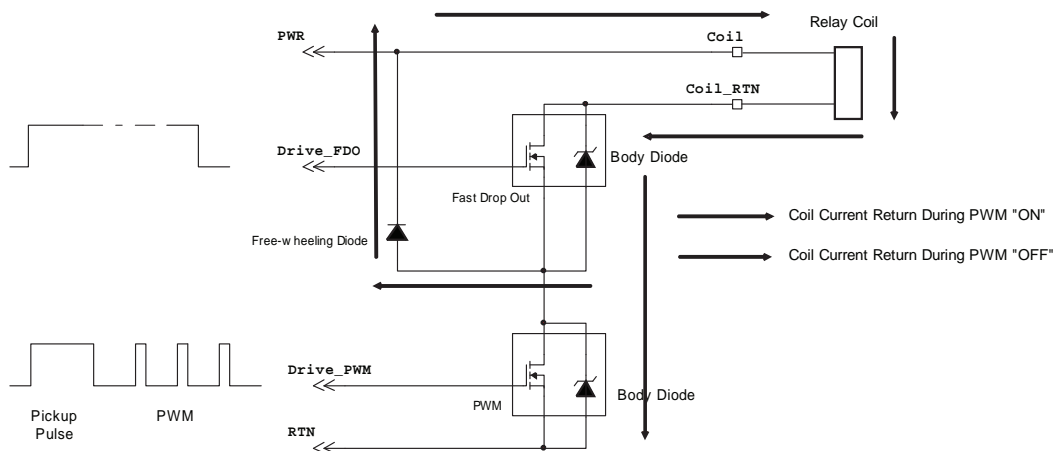

Fast Drop-out FET stays on during operation. FDO and Power can be applied simultaneously

Filtering/Protection should be applied to FET gates as required.

For higher energy coils, additional TVS protection may be required across FET drain-to-source.

Figure 1
Coil Drive Circuit

Application Notes on Coil Power Economizing using PWM Circuits (Continued)

This fast opening is useful for circuit interruption, and it allows the over travel mechanism of the contact actuator to work effectively in breaking minor contact welds that may occur when closing the contacts.

Allowing the free-wheeling diode to remain across the coil would significantly increase the contact opening time and opening speed, and possibly result in nuisance contact welds and/or reduced capability to interrupt circuit currents.

If additional diodes are required to protect the FET body diodes, select a Transient Voltage Suppressor (TVS) diode with a breakdown rating lower than that of the driver FET body diode. In general, a higher voltage TVS diode will result in faster contact opening and higher clamping voltage, while a lower voltage TVS diode will result in slower contact opening and lower clamping voltage. For more detailed information regarding TVS diode selection, contact TE and request the report titled [DC Relay Magnetic Energy Determination and Transient Voltage suppressor Diode Selection](#).

1.1 Recommended Operating Frequency and Duty Cycle

The frequency at which the PWM circuit is operated should be high enough such that the oscillation of the coil current does not lead to audible noise being generated by the magnetic components and coil winding. For most KILOVAC contactors, a coil drive frequency > 15 kHz is usually sufficient to ensure that nuisance audible noise is not generated. The PWM duty cycle required for economizing power while maintaining sufficient holding force can be calculated from the required holding current as follows:

$$\text{Duty Cycle(\%)} = (I_{\text{hold}} \cdot R(T)_{\text{Coil}} / V_{\text{source}}) \cdot 100 \quad (1)$$

Where:

R(T) = Coil Resistance at Temperature

I_{hold} = Required Holding Current

V_{source} = Source Voltage

Contact TE regarding the minimum required hold current needed for a particular Part Number. In general, divide the specified dropout voltage by the coil resistance at 20°C, and add 25% above that to get an estimate of the value to use in equation (1) for I_{hold}.

2.0 Summary

This Application Note is meant to address some of the more common questions regarding the use of PWM circuits for coil power economization. In all cases, please refer to the applicable product data sheet for specific information.

TE can also recommend alternative solutions for mechanical dual-coil economizers, as well as “Electronic Cut-Throat” economizers. Product Application Engineers are available to answer questions regarding this subject by calling 800-253-4560 x2055, or 805-220-2055.

Engineering Notes

