

BENEFITS OF A HYBRID CONNECTIVITY SOLUTION OVER PODL

Hybrid Connectivity in M8 and M12 Form Factor

Ruud van den Brink

Product Manager
Industrial Communications

Wijnand van Gils

Principal R&D
Product Dvl Engineer

Peter Jaeger

Sr Principal R&D
Product Dvl Engineer



Benefits of a Hybrid Connectivity Solution over PoDL

Hybrid Connectivity in M8 and M12 Form Factor

Introduction

Single Pair Ethernet (SPE) attracts more and more attention within the industrial area. By the reduction of the number of wires from four or eight of traditional Ethernet to only two, it enables smaller cable diameters and connector sizes and eases the termination. From a topology point of view, we can have point to point connections up to 1000 m or a bus system up to 25 m by which it becomes an interesting alternative for the field bus systems. With SPE, power can be transferred on the same wires that are used for the data transmission. This technique is referred to as power over data lines (PoDL).

For many applications PoDL might be sufficient. However, for industrial applications we propose a hybrid connectivity solution. For this we have a connector that has separated contacts for data and power. This brings several advantages compared to PoDL. One is transferring higher power levels due to higher currents and voltages. Another advantage is that the printed circuit board (PCB) real estate will decrease. Also, less power conversions are needed improving the power efficiency of your system, which also reduce the need for heat dissipation. And lastly it can handle higher noise levels on the power.

We have two variants here. First, we have a hybrid connector in an M8 form factor with one data pair and one power pair, which is standardized in IEC 63171-6^[1] and discussed in “Higher Power Levels for Single Pair Ethernet” whitepaper ^[2]. This connector can support 8 A of current and a voltage up to 60 VDC. Second, we have a hybrid connector in an M12 form factor with one data pair and one or two power pairs. This variant is currently standardized in IEC 63171-7^[3] and discussed in “Single Pair Ethernet – M12 Hybrid System” ^[4]. It can handle currents of 16 A with a maximum voltage of 600 VDC.

In the paper we will discuss the capabilities of these hybrid connectivity solutions compared to existing powering solutions.



Ruud van den Brink
Product Manager
Industrial Communications

International marketing and sales professional with 35+ years of experience in a B2B environment. In his current role his background and in-depth knowledge in wireless and wired communication is a major asset.



Wijnand van Gils
Principal R&D
Product Dvl Engineer

He joined TE Connectivity in the antenna development team in 2007. Since 2016, as principal product dvl engineer he develops connectors for Ethernet applications used in industrial environments.



Peter Jaeger
Sr Principal R&D
Product Dvl Engineer

Mechanical engineer with long-term experience in developing various signal, power and hybrid connector systems. Keen interest in combining knowledge in contact design, physics, materials and plating for contact design optimization.

Powering Methods with SPE

There are three different ways to power a device connected with SPE, which are using a separate power and data cord, using PoDL and using a hybrid powering solution. Each of them is visualized in Figure 1 and they all show how the data is transmitted from SPE to SPE module and the power from the power sourcing equipment (PSE) to the powered device (PD). Their advantages and disadvantages are discussed below.

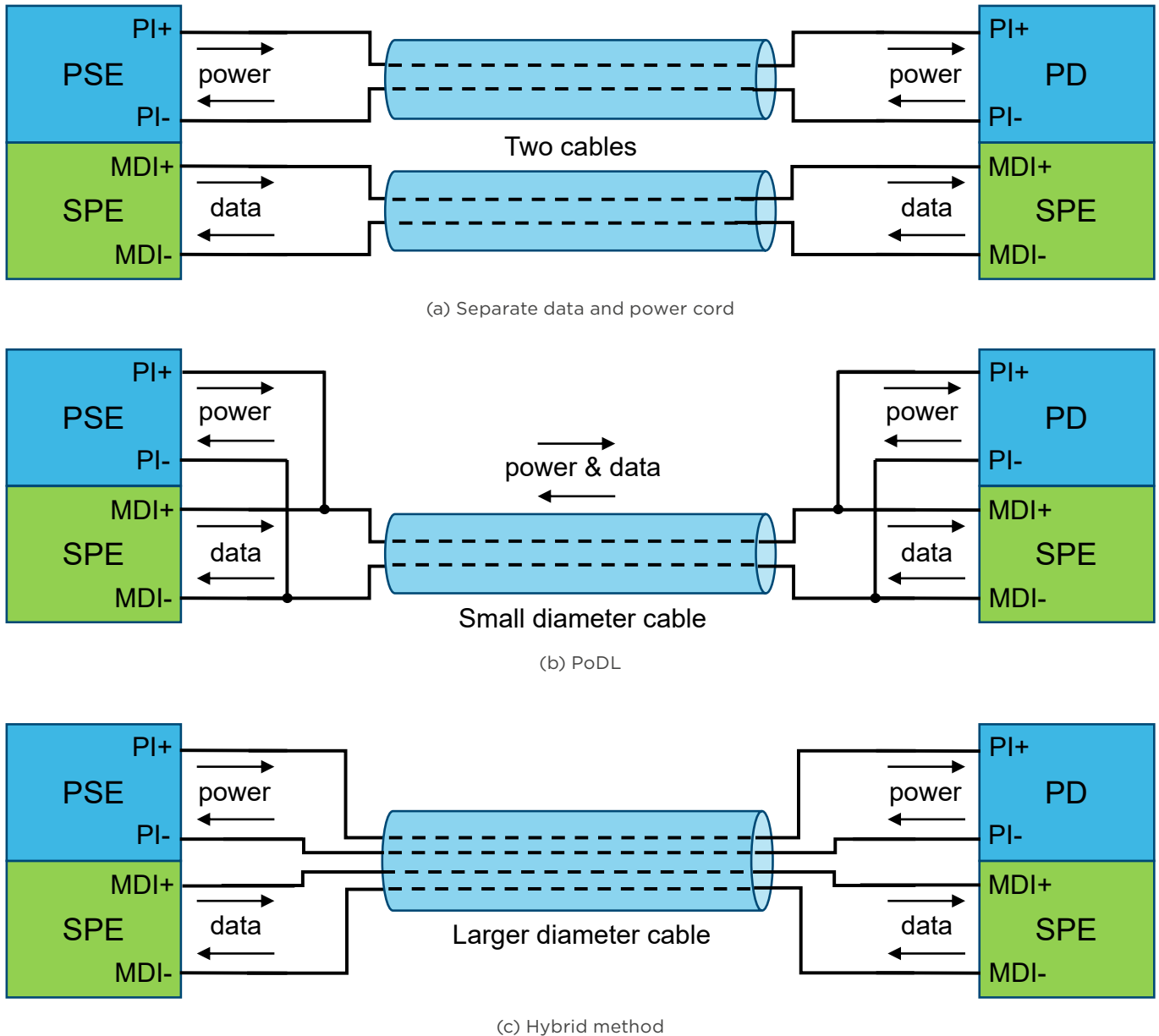

Figure 1: Powering methods

The first method, to supply a device to the power grid by using a separate power cord is the conventional way to supply power to your device. The amount of power you need is only limited by the power grid and the used power cord and therefore it will basically not provide a limitation. The downside is that the cabling effort increases because you need to connect two cables instead of one. Also, it consumes a lot of cable space.

Benefits of a Hybrid Connectivity Solution over PoDL

Hybrid Connectivity in M8 and M12 Form Factor

The second method is by using PoDL. With PoDL the power is transmitted over the same wires that are used for the data. Hence, you only need one cable instead of two cables when using a separate power cord. Also, this single cable has a small diameter. This enables a more efficient use of the cable space and cable weight. The downsides are that the amount of power transfer is limited here. According to IEEE802.3bp^[5] the maximum power transfer is 50 W over a cable length of 40 m. In IEEE 802.3cg^[6] the maximum power transfer is 52 W. Furthermore, extra electronics are needed to use PoDL and till now PoDL does not support multidrop topologies. These items will be discussed later in more detail.

The last method is by using a hybrid connectivity solution where, in our case, we have one data pair combined with one or more power pairs in the connectors and cables. Compared to the method with a separate power cord, a hybrid solution will bring the benefit that it uses the cable space more efficient. Although not as efficient as PoDL does. Advantages of a hybrid solution compared to PoDL are that higher power levels are possible, you can use it in multidrop topologies, you do not need special circuitries to feed and remove the power to the data lines and due to the galvanic isolation between data and power, it is more resilient to noise on the power lines.

Hybrid Connectors

The M8 hybrid is shown in Figure 2. As the name implies, it fits within an M8 form factor. The mating interface consists of two signal pins and two power pins. The power pins are larger in diameter than the signal pins to allow for higher currents. In between there is a shield to minimize the crosstalk between power and data.



Figure 2: M8 hybrid connector.

An example of the M12 hybrid connector is shown in Figure 3. The M12 hybrid connector fits within an M12 form factor. Different mating interfaces are defined in IEC 63171-7, which are shown in Figure 4. Depending on the power that needs to be transferred, different mating interfaces can be chosen. The different interfaces can be categorized into three different groups.

Benefits of a Hybrid Connectivity Solution over PoDL

Hybrid Connectivity in M8 and M12 Form Factor

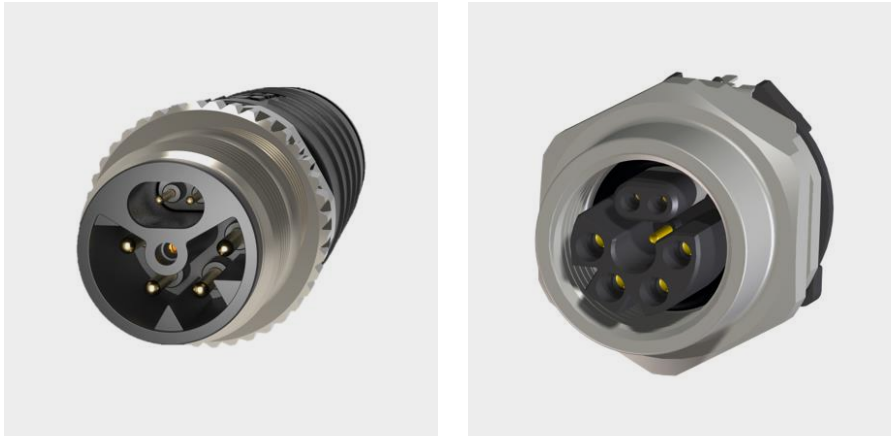

Figure 3: M12 hybrid connector, coding Type II.

The first group refers to type I, II, III and VI and is defined for the non-hazardous voltages (≤ 63 VDC or < 50 VAC). The types can vary in rated currents and the power pin layout. The power contact for type I, II and III can handle currents up to 8 A and is connected to wires of 16 American Wire Gauge (AWG). In type I the two left power contacts are shorted with each other and the two right power contacts are shorted with each other. This enables the interface to handle higher currents up to 12 A. Here, each power contact is connected to wires of 17 AWG. Type VI supports 16 A by utilizing two larger power contacts that are connected to 14 AWG wires. This variation in different wire gauges is important for the amount of power it will transfer over distance. This is elaborated on a later section. Lastly, type III and VI include a functional earth.

The second group refers to type IV and VII and is defined for hazardous voltage (≤ 600 VDC or ≤ 600 VAC). Type IV and VII can handle 8 and 16 A on their power contacts and are connected to wires of 16 AWG and 14 AWG, respectively. Due to the high voltage level they include a protective earth (PE) contact.

The third group is represented by type V and is meant for three-phase applications. It is able to be used for voltages up to 480 VAC and current up to 8 A. Also here, due to the high voltages a protective earth contact is included.

POWER	Single / Dual Phase / DC				3-Phase	Single / Dual Phase / DC	
	< 50 VAC ≤ 63 VDC		≤ 600 VAC ≤ 600 VDC		≤ 480 VAC	≤ 50 VAC ≤ 63 VDC	≤ 600 VAC ≤ 600 VDC
	12 A max.	2x 8 A max.	8 A max.	8 A max.	8 A max.	16 A max.	16 A max.
	Type I	Type II	Type III	Type IV	Type V	Type VI	Type VII
MALE							
FEMALE							

Pin contact
 Socket contact
 Closed hole (Type III & IV only)

Figure 4: M12 hybrid interface types in IEC 63171-7.

Benefits of a Hybrid Connectivity Solution over PoDL

Hybrid Connectivity in M8 and M12 Form Factor

Comparison

NETWORK TOPOLOGIES / POWER DISTRIBUTION STRUCTURES

With PoDL designs, only a point-to-point connection is possible. Within the working group IEEE 802.3da investigations are ongoing to extend PoDL to power several PDs with one PSE. Here the focus is on data rates of 10 Mbit/s only. By splitting signal and power on separate lines by using the hybrid cabling solution we obtain more freedom in implementing the power network. With the additional power lines of the hybrid connector more than one PD can be powered and, of course alternatively, PoDL can be used simultaneously as well. Examples of possible topologies to power devices (represented by nodes in the figure) in a network are shown in Figure 5.

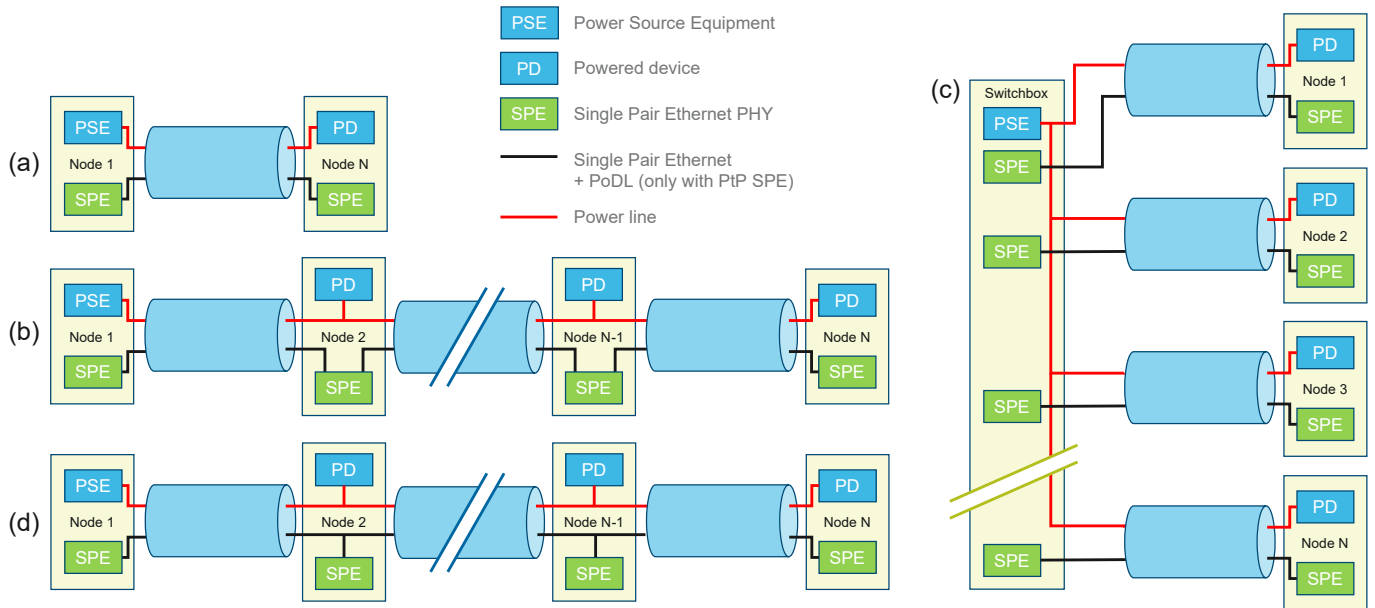

Figure 5: Network topologies hybrid connector: (a) Point to point, (b) SPE daisy chained and power on a bus, (c) Switch with hybrid power source, (d) SPE and power on a bus

- **Point-to-point (P2P) cabling solution (a)**

This is similar to most Ethernet communication. Here, the power over the separate power lines is applied point-to-point in case we need to have a high amount of power for one PD. In case PoDL is used in addition, we can use the power lines to power devices like actuators that generate electromagnetic compatibility (EMC) noise and supply power to noise sensitive devices like the SPE PHY chips with PoDL.

- **SPE daisy chained and power on a bus (b)**

Often in automation networks the devices are installed in a daisy change topology where every device contains a network switch. With the M12 hybrid connectivity solution the power can be supplied directly to all devices via one power source.

- **Hybrid SPE switching solution (c)**

From a switch with a hybrid power source, the power to multiple devices can be delivered via one power source.

- **SPE and power on a bus (d)**

Multidrop SPE does not, have the possibility to add PoDL. With the hybrid solution the power can be supplied via the extra power lines,

Power Transfer with Hybrid Connectors

With PoDL the highest power level that can be transmitted is 50 W with a maximum current of 1.36 A for a data rate of 1 Gbps and 52 W with a maximum current up to 1.579 A for a data rate of 10 Mbps as defined in IEEE802.3bu and IEEE802.3cg, respectively. For this the highest voltages on the wire pair from the Power Supplying Equipment (PSE) side is 60 VDC.

Benefits of a Hybrid Connectivity Solution over PoDL

Hybrid Connectivity in M8 and M12 Form Factor

The M8 and M12 hybrid connectors support higher currents and, depending on the interface type of the M12 hybrid connector, higher voltages. Therefore, significant higher power levels above 52 W are possible. To understand the amount of power the hybrid connector can support, we have to understand the voltage drop that occurs over the cable to the powered device. This voltage drop is related to the resistance of the power wires in the cables. This is why the design and length of the cable are crucial here. To get insight in the amount of power that can be transmitted we assume the circuitry shown in Figure 6.

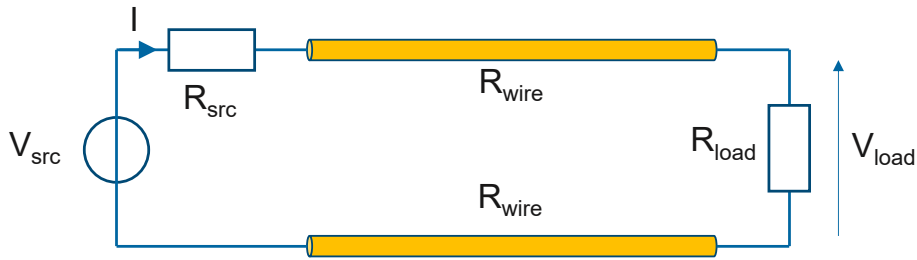

Figure 6: Basic circuitry for power transfer

On the left we have the Power Sourcing Equipment (PSE) that include a voltage source V_{src} with internal resistance R_{src} . The second part is the cable with losses and on the right, we have the powered device (PD) represented by a load resistance that requires a specific voltage range. With such simplified model we can determine the transferred power with the necessary current over a specific length of cable. In the next sections the transferred power of the M8 hybrid connector and a few representative interfaces of the M12 hybrid connector are presented. For simplification the source resistance R is neglected. The amount of transferred power is determined by the wire gauge of the cables, 40 m cable length which represents the maximum distance for 1 Gbps data rate and the maximum allowed working voltage.

M8 HYBRID CONNECTOR

The M8 hybrid connector has copper wires of 18 AWG for the power lines with a working voltage up to 60 VDC. This gives us the transferred power for a cable length of 20 and 40 m as given in Figure 7.

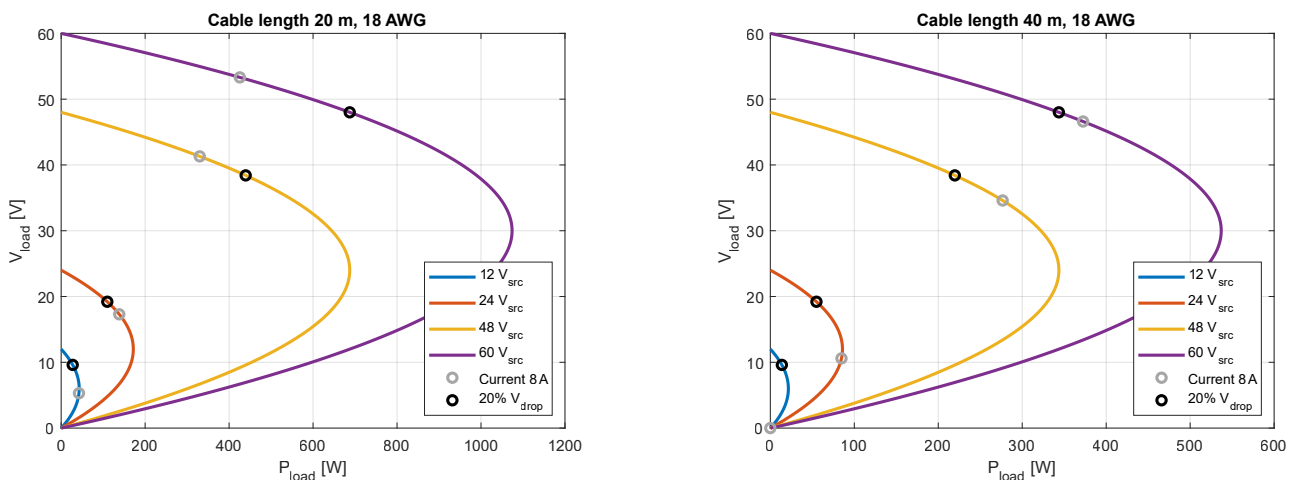

Figure 7: Transferred power for M8 hybrid.

Benefits of a Hybrid Connectivity Solution over PoDL

Hybrid Connectivity in M8 and M12 Form Factor

On the left side of these graphs we can see that if the power increases, the voltage of the load will drop, which is caused by the increase of current through the power pair. When the voltage drop is 50% we see that the amount of transferred power is at a maximum, but typically this maximum is not used due to instability issues it causes for the PDs. Most electrical devices in this voltage range accept a maximum voltage drop of 10% of the source voltage equaling to a power efficiency of approximately 80%. However, here we compare the powers at a voltage drop of 20% which is comparable with PoDL and field busses. This 20% voltage drop is represented by the small black circle. Here we see that with a source voltage of 60 V we can transfer power close to 350 W over a cable length of 40 m.

If the cable length is shorter, like in the left graph, then the transferred power is above 400 W.

M12 HYBRID CONNECTOR TYPES II, III (VOLTAGES UP TO 50 VAC_{rms})

If we take the losses of an 16 AWG copper wire used for these interfaces we obtain the results of a cable length of 20 and 40 m as shown in Figure 8.

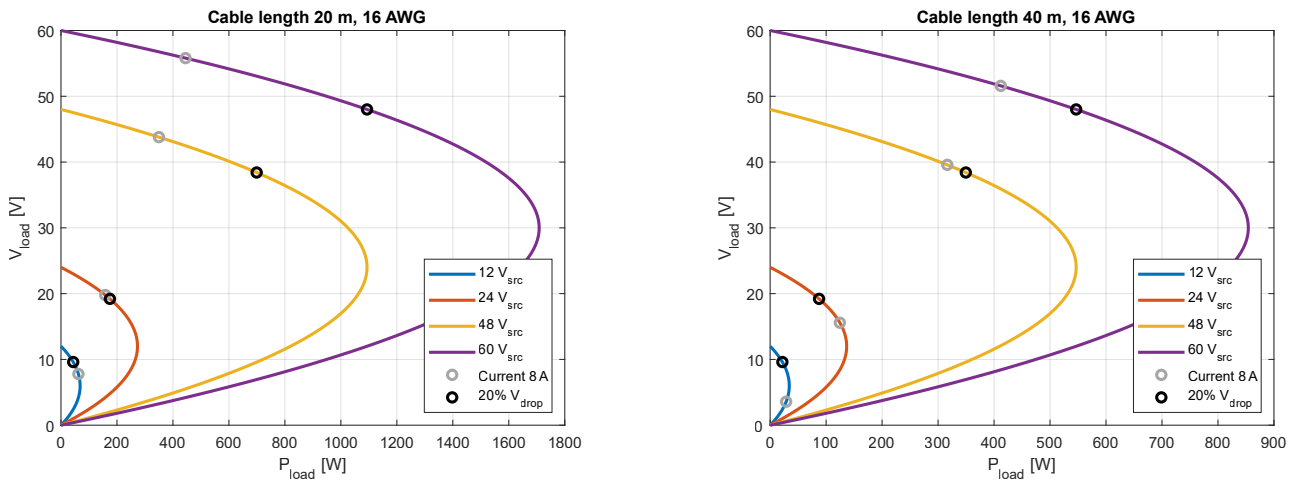

Figure 8: Transferred power for M12 hybrid interfaces II and III.

With a source voltage of 60 V we see that a power of more than 400 W can be transferred over both 20 as well as 40 m cable distance. In the type II interface we have two power circuits, meaning that 2 times 400 W of power can be transferred. Here the maximum power is limited by the amount of current. If we check the amount of transferred power for a source voltage of 24 V, the transferred power is close to 100 and 200 W for a cable length of 40 and 20 m, respectively. Note that for the 20 m the power is limited by the maximum amount of current the connector can handle. However, for 40 m the power is limited by the source voltage.

Benefits of a Hybrid Connectivity Solution over PoDL

Hybrid Connectivity in M8 and M12 Form Factor

M12 HYBRID CONNECTOR TYPE V (HAZARDOUS VOLTAGE AND THREE-PHASE)

For a three-phase system with 16 AWG wires and a phase voltage of $480 V_{rms}$, we can transfer power levels above 6 kW over 40 m. With a maximum voltage drop of 5%, typically no larger voltage drops are accepted for these voltage levels, we see that the maximum current of 8 A is limiting the power level here. If the power is limited due to the maximum current, it also means that over longer length high power levels can be transferred. On the right we see such graph for a cable length of 100 m where we still can handle more than 6 kW of power.

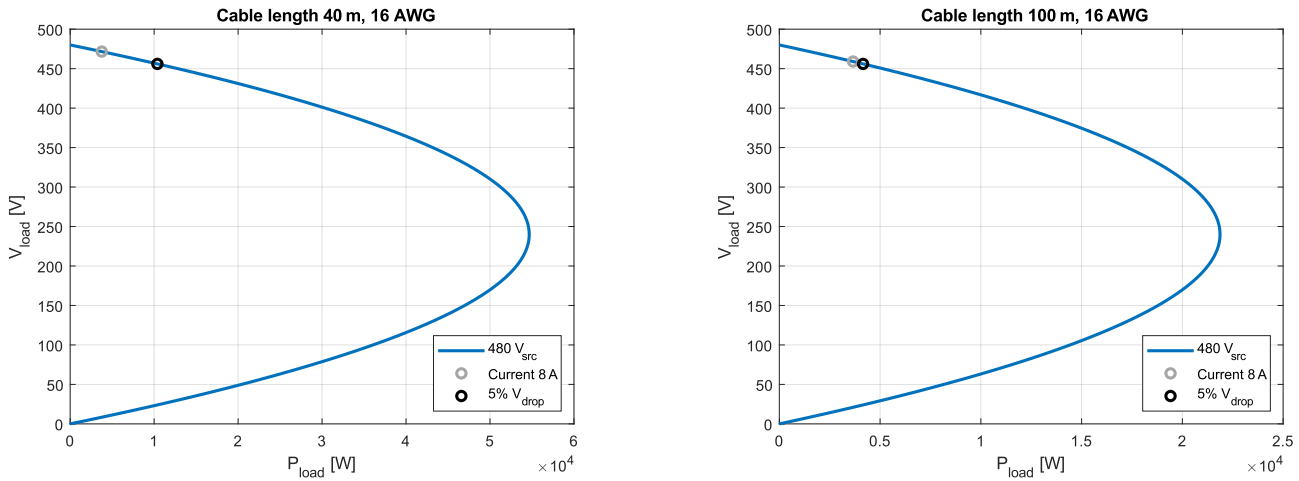

Figure 9: Transferred power for M12 hybrid interface V.

POWER TRANSFER WITH CONNECTOR CODE TYPE VII AND CABLE (HAZARDOUS VOLTAGE)

The power contacts in the connector interface Type VII will be connected to a 14 AWG copper wire. The results are given in Figure 10. With a source voltage of 600 V and assuming a maximum 5% voltage drop we can see that a power of more than 9 kW can be transferred over 40 m cable distance, where the power is limited due to the maximum current of 16 A.

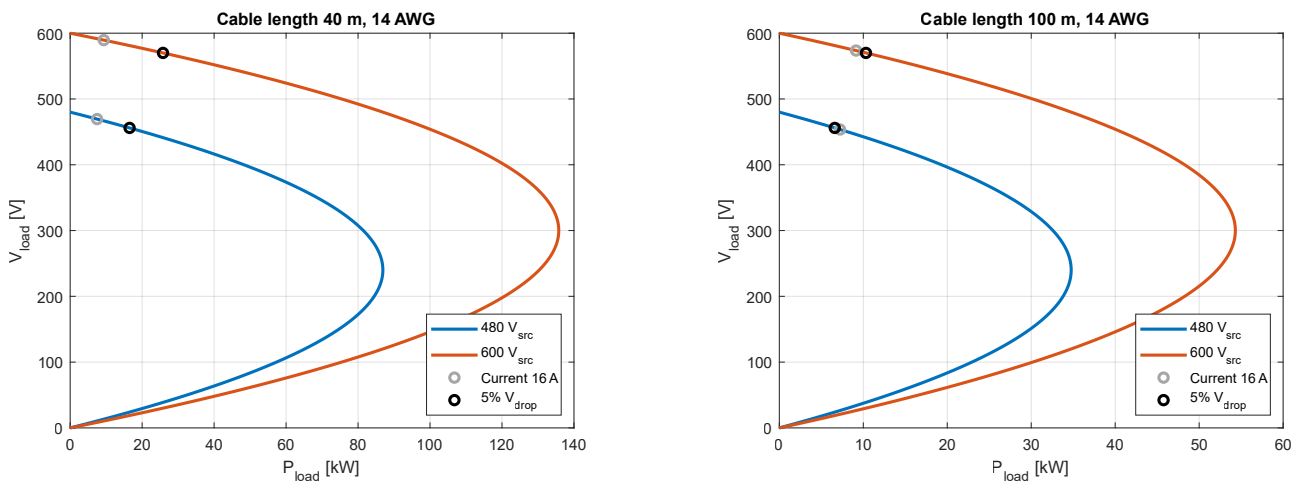

Figure 10: Transferred power for M12 hybrid interfaces VII.

Benefits of a Hybrid Connectivity Solution over PoDL

Hybrid Connectivity in M8 and M12 Form Factor

PSE AND PD CIRCUITRIES

Choosing for a hybrid powering solution instead of PoDL also requires less PCB real estate. To get a better understanding of this, a typical coupling network for SPE is shown in Figure 11. Both solutions have components for the data channel. This includes a PHY for the data communication, a transformer for the high voltage protection, a common mode termination that can also include a common mode choke (CMC) for higher frequencies and an MDI connector that can handle SPE. However, with PoDL we also require a coupling circuit at the PSE to feed the power to the data lines and a decoupling circuit at the PD to separate the power from the data lines. This is represented in Figure 11 as a low pass filter. For currents up to 1 A, the used PCB area of the coupled inductors can go up to 15x15 mm with a height of 10 mm. If going to higher currents of 1.5 A, often the coupled inductors must be replaced by two separate inductors that require more volume to obtain a similar impedance. Here the required PCB area can easily double. Hence, the hybrid powering solution that helps avoid these coupling and decoupling circuits, becomes an excellent solution for higher current levels.

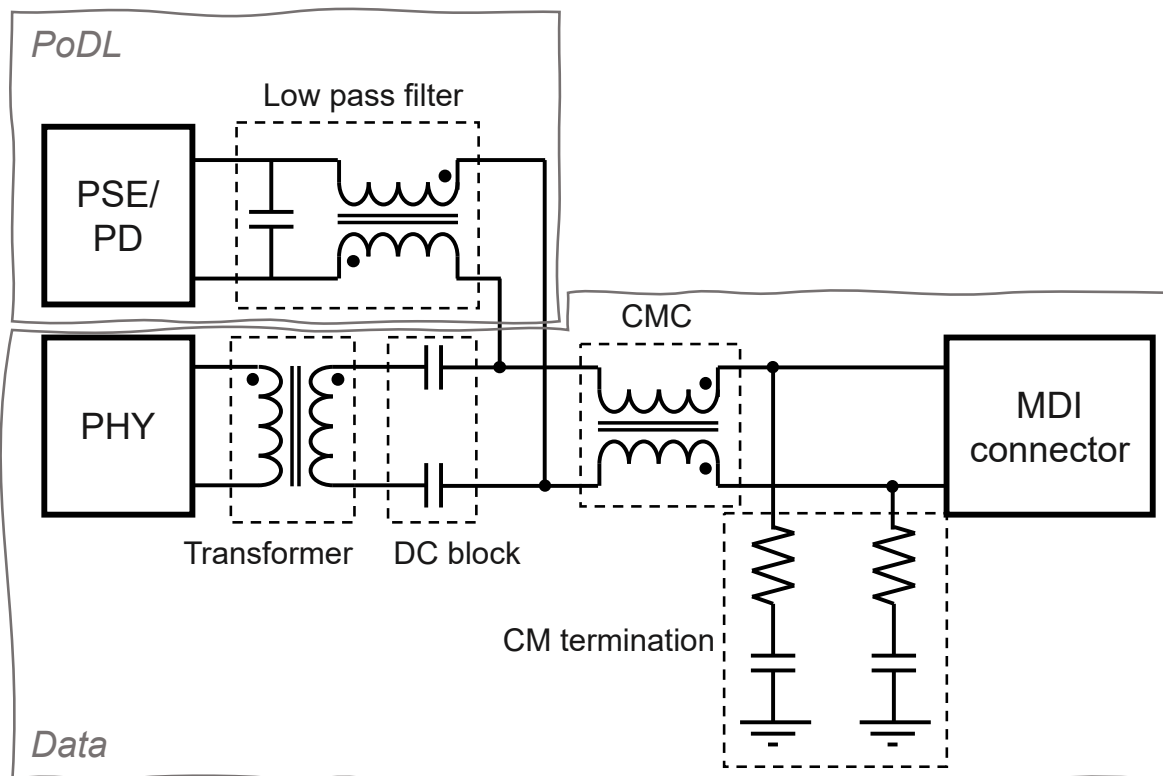

Figure 11: Coupling network SPE and PoDL.

Furthermore, with PoDL the PSE and PD require circuitries to handle PoDL functionalities like classification and/or detection. With the classification functionality the PSE and PD communicate with each other at which voltage level the power should be delivered. With the detection functionality the PSE checks if a PD is connected on the other side of the cable. To achieve these functionalities, extra components on the PSE and PD circuits are needed. These PoDL functionalities and (de)coupling circuitries can make the required circuitries easily 50% larger and in combination with the large size of the low-pass filters in the (de)coupling circuitries less attractive for products with a small form factor such as sensor nodes.

Benefits of a Hybrid Connectivity Solution over PoDL

Hybrid Connectivity in M8 and M12 Form Factor

Note that instead of having the functionality classification, the hybrid connectivity solution includes different connector interface types to handle different voltage levels. This is a similar functionality. Also, instead of detection which helps ensure that no one can touch powered contacts, the open end of a powered hybrid connectivity solution always is a female connector. This also reduces the chances of anyone touching the powered contacts since the open power contacts are covered within the connector housing.

POWER EFFICIENCY

For PoDL and the hybrid solution, you have the Ohmic losses in the copper wires of the cable which have been discussed in the section 'Power Transfer with Hybrid Connectors'. Also, in the coupling circuits required for PoDL we have Ohmic losses caused by the coupled inductors which can be in up to 1 Ohm. For higher currents this creates unwanted losses in the coupled inductors up to a few watts, causing thermal heating.

Another area where the losses are significant is in the DC-DC converters required in the power circuits. Typical efficiencies of DC-DC converters vary between 80 to 95% and are typically around 90%. They are needed in both PoDL and hybrid powering solutions. However, if we want to start daisy chaining devices, PoDL requires another DC-DC converter with every daisy chain. This can cause severe losses making PoDL an unattractive method in such applications.

Conclusion

Hybrid connectivity and PoDL are complementary technologies. PoDL has the advantage to achieve extreme low cable diameters and with that achieving a low weight cabling solution. Hybrid connectivity has the advantage that although the cable diameter becomes larger, it supports much larger power levels and different topologies. Also, it does not require the coupling circuits that you need for PoDL, therefore the PCB real estate is reduced and less thermal heating is occurring. These advantages are important for many industrial use cases and thus makes a hybrid connectivity solution a strong candidate for industrial SPE implementations.

References

- [1] “IEC 63171-6, Connectors for electrical and electronic equipment – Part 6: Detail specification for 2-way and 4-way (data/power), shielded, free and fixed connectors for power and data transmission with frequencies up to 600MHz,” IEC, 2021
- [2] W. v. Gils, P. Jaeger and M. Hilgner, “Higher Power Levels for Single Pair Ethernet,” TE Connectivity, 2020. [Online]. Available: <https://www.te.com>
- [3] “IEC 63171-7, Connectors for electrical and electronic equipment – Part 7: Detail specification for 4-way to 6-ways plus PE or FE (data/power) shielded, free and fixed circular connectors for balanced single-pair data transmission current-carrying capacity,” IEC, 2021
- [4] F. Vorhagen, H. Messerer, R. v. d. Brink, P. Jaeger, W. v. Gils and M. Fritsche, “Single Pair Ethernet – M12 Hybrid System,” Industrial Partner Network, 2022. [Online]. Available: <https://www.single-pair-ethernet.com>
- [5] “IEEE Std 802.3bp™-2016, Amendment 4: Physical Layer Specifications and Management Parameters for 1 Gb/s Operation over a Single Twisted-Pair Copper Cable,” IEEE, 2016
- [6] “IEEE Std 802.3cg™-2019, Amendment 5: Physical Layers Specifications and Management Parameters for 10 Mb/s Operation and Associated Power Delivery over a Single Balanced Pair of Conductors,” IEEE, 2019

ABOUT TE CONNECTIVITY

TE Connectivity is a global industrial technology leader creating a safer, sustainable, productive, and connected future. Our broad range of connectivity and sensor solutions, proven in the harshest environments, enable advancements in transportation, industrial applications, medical technology, energy, data communications, and the home. With more than 85,000 employees, including over 8,000 engineers, working alongside customers in approximately 140 countries, TE ensures that EVERY CONNECTION COUNTS. Learn more at LinkedIn, Facebook, WeChat and Twitter.

CONNECT WITH US

TE Connectivity is committed to helping manufacturers adopt SPE technology and experience the benefits of real-time communication. Connect with our experts - we are ready to provide the support you need - **click here to connect**.

te.com

©2023 TE Connectivity. All Rights Reserved.

TE, TE Connectivity, TE connectivity (logo), and EVERY CONNECTION COUNTS are trademarks owned or licensed by the TE Connectivity Ltd. family of companies. Other product names, logos, and company names mentioned herein may be trademarks of their respective owners.

The information given herein, including drawings, illustrations and schematics which are intended for illustration purposes only, is believed to be reliable. However, TE Connectivity makes no warranties as to its accuracy or completeness and disclaims any liability in connection with its use. TE Connectivity's obligations shall only be as set forth in TE Connectivity's Standard Terms and Conditions of Sale for this product and in no case will TE Connectivity be liable for any incidental, indirect or consequential damages arising out of the sale, resale, use or misuse of the product. Users of TE Connectivity products should make their own evaluation to determine the suitability of each such product for the specific application.

JS 02/23