

Attracting Tomorrow



Single Pair Ethernet (SPE) in Industrial Applications

Inductor solutions for 10BASE-T1L

TDK Electronics AG
Magnetics Business Group • MAG IN PM
Munich, Germany
April 2024

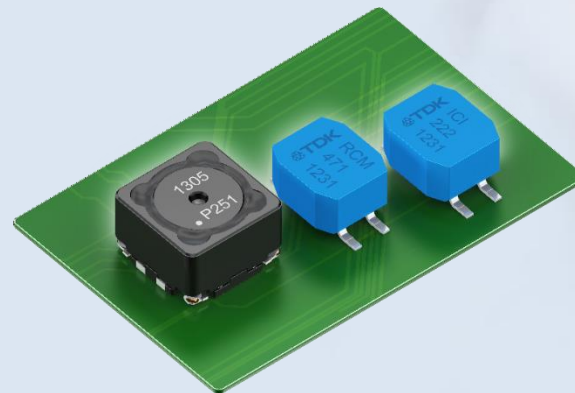

Single Pair Ethernet Motivation & Terminology

Motivation

SPE fulfills one of the essential requirements for IoT and Industry 4.0 applications: Continuous intelligent networking across all levels

- **Consistent:** Uniform Ethernet-based communication from the sensor to the cloud
- **Future-proof:** Comprehensive key technology for Industry 4.0 and IoT
- **Simple:** Reduced cabling effort by reducing to only one pair of wires
- **Flexible:** Can be used across applications with ranges of up to 1,000 m and transmission speeds of up to 1 Gbit/s

Terminology

- **SPE** = Single Pair Ethernet, alternative standard to regular LAN, data rates up to 1 Gbit/s with one pair of cables
- **PoDL** = Power-over-DataLine, working with one-pair PHYs and cable length of up to 1,000 m
- **SPoE** = Single Pair Power over Ethernet, different naming for PoDL
- **PoE** = Power-over-Ethernet, working with 2-pair and 4-pair PHYs
- **10BASE-T1L** = Physical layer standard (IEEE Standard 802.3cg-2019), data rate 10 Mbit/s

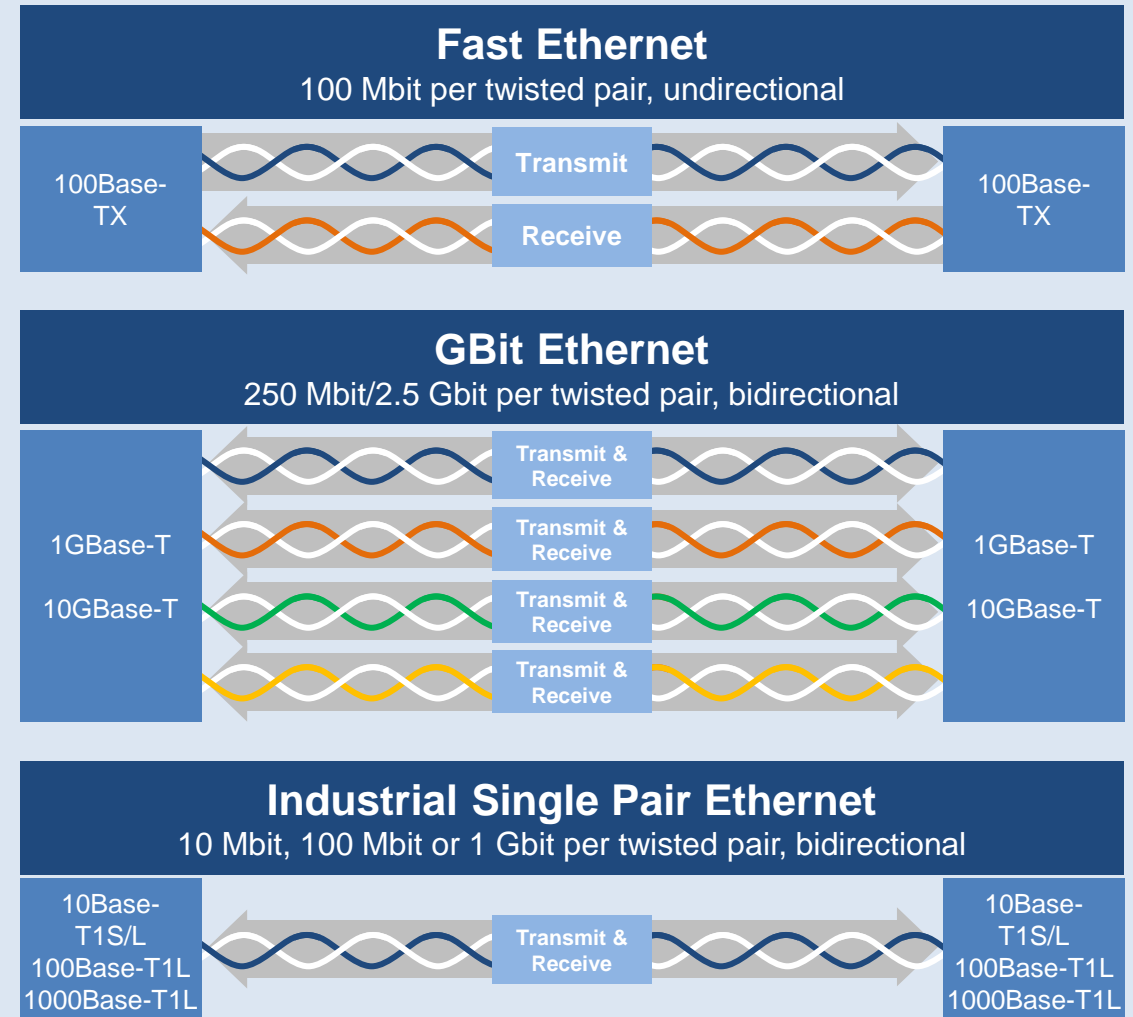

Single Pair Ethernet Product Line-up

Common-Mode Choke (CMC)

- Used for suppression of asymmetrical interference
- Rated inductance of 470 μH
- Rated current up to 700 mA ideally for PHY side injection up to IEEE 802.3cg-2019 power class 15

Isolation Inductors (Isolation)

- Used for galvanic isolation or 1:1 coupling of data signal
- Rated inductance of 1.0 mH or 2.2 mH
- Voltage strength up to 2250 V DC

Differential Mode Inductors (DMI)

- Used to enable power over DataLine (PoDL)
- Suitable for both IEEE 802.3cg-2019 and APL power classes
- Rated inductance with 56 μH , 65 μH or 250 μH per winding
- Functional isolation up to 500 V
- Sizes depending on current transmission from 7.5 x 7.5 up to 15.5 x 15.5 mm

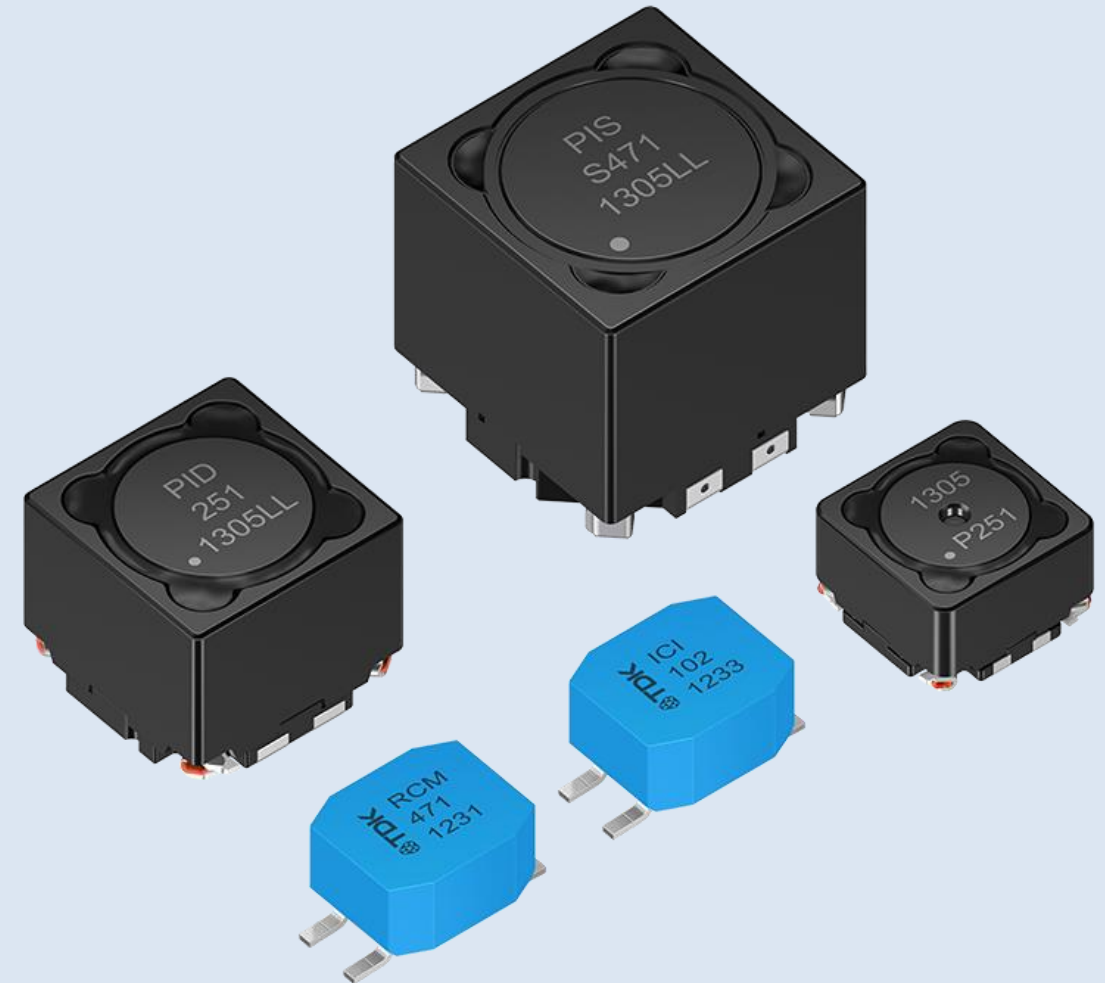

Single Pair Ethernet System Considerations

$V_{PSE\ max.}$ ($V_{PSE\ OC\ max.}$)	30 V (20 V)			58 V (40 V)		
Class	Class 10	Class 11	Class 12	Class 13	Class 14	Class 15
$I_{PI\ max.}$	92 mA	240 mA	632 mA	231 mA	600 mA	1579 mA
$P_{class\ min.}$ ($P_{PD\ max.}$)	1.85 W (1.23 W)	4.8 W (3.2 W)	12.63 W (8.4 W)	11.54 W (7.7 W)	30 W (20 W)	79 W (52 W)
$V_{PD\ min.}$	14 V	14 V	14 V	35 V	35 V	35 V
Cable AWG/length	18/1000 m	14/1000 m	24/300 m	18/1000 m	14/1000 m	24/300 m

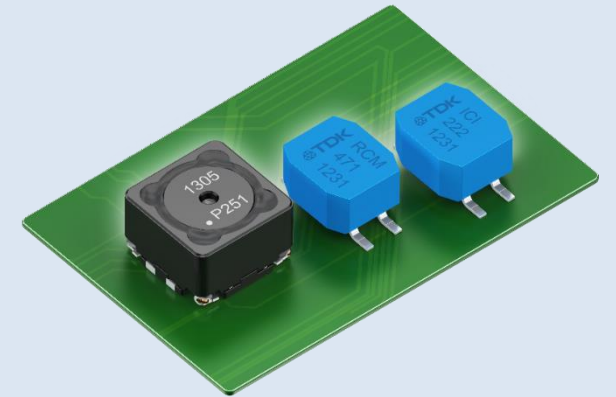

OC: Open circuit voltage
PI: Power interface

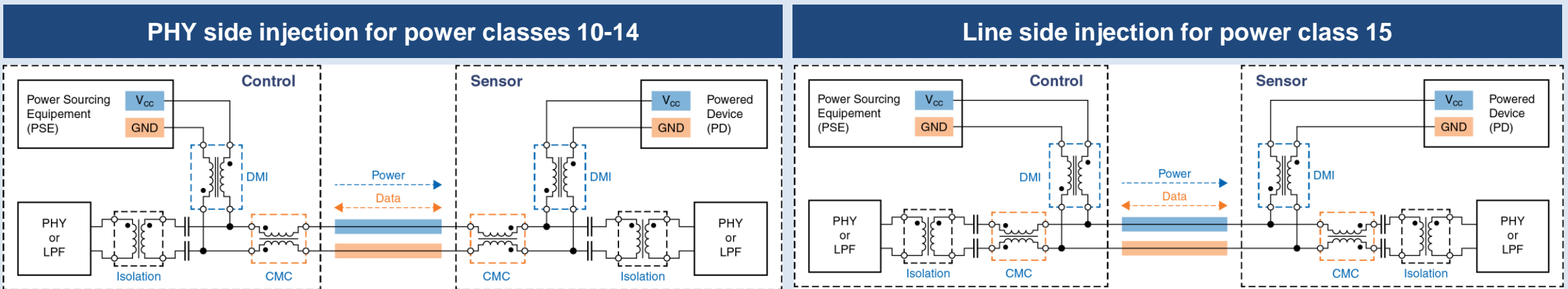

TDK Solutions for 10BASE-T1L Common-mode Choke RCM70CGI

Features

- Temperature range -40 to +125 °C (incl. self-heating)
- Suitable for lead-free reflow soldering as referenced in JEDEC J-STD 020E
- High current rating



Applications

- Industrial Single Pair Ethernet (SPE)
- Common-mode choke for 10BASE-T1L (IEEE 802.3cg-2019)

Electrical characteristics

Part #	L_R [μH]	Tol. [%]	$L_{stray, typ}$ [nH]	$R_{DC, typ}$ [Ω]	I_R, typ [mA]	V_{test} [V] 2 seconds
RCM70CGI-471	470	+/-30	110	0.17	700	250

DC resistance R_{DC} : Specified per winding

Rated current I_R : Based on the temperature increase (40 K by self-heating); ambient temperature: 85 °C

Dimensional drawing and pin configuration

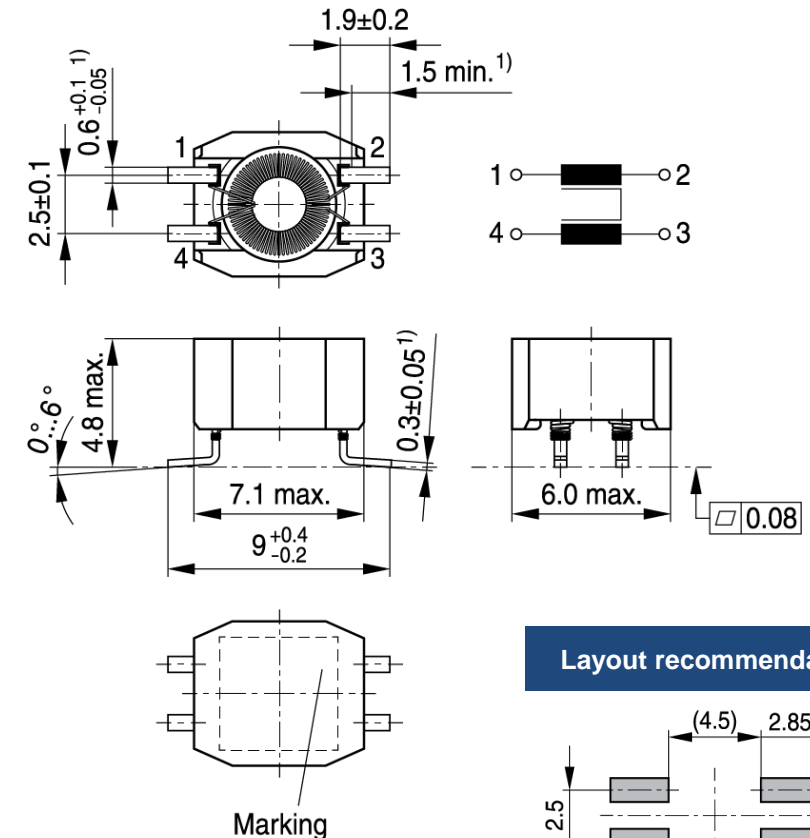

1) Soldering area

Layout recommendation

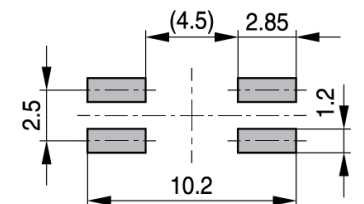

TDK Solutions for 10BASE-T1L Isolation Inductors ICI70CGI

Features

- Temperature range -40 to +125 °C (incl. self-heating)
- Suitable for lead-free reflow soldering as referenced in JEDEC J-STD 020E
- High isolation capability

Applications

- Industrial Single Pair Ethernet (SPE)
- Isolating inductor for 10BASE-T1L (IEEE 802.3cg-2019)

Electrical characteristics

Part #	L_R [mH]	Tol. [%]	$L_{stray, typ}$ [nH]	$R_{DC, typ}$ [Ω]	C_{typ} [pF]	V_{test} [V] 2 seconds
ICI70CGI-102	1.0	-30/+50	150	0.165	14	2250
ICI70CGI-222	2.2	-30/+50	150	0.420	18	2250

DC resistance R_{DC} : Specified per winding

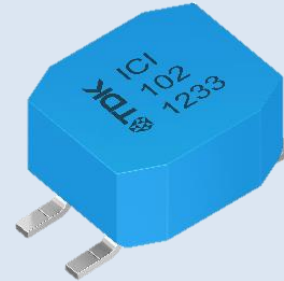

Dimensional drawing and pin configuration

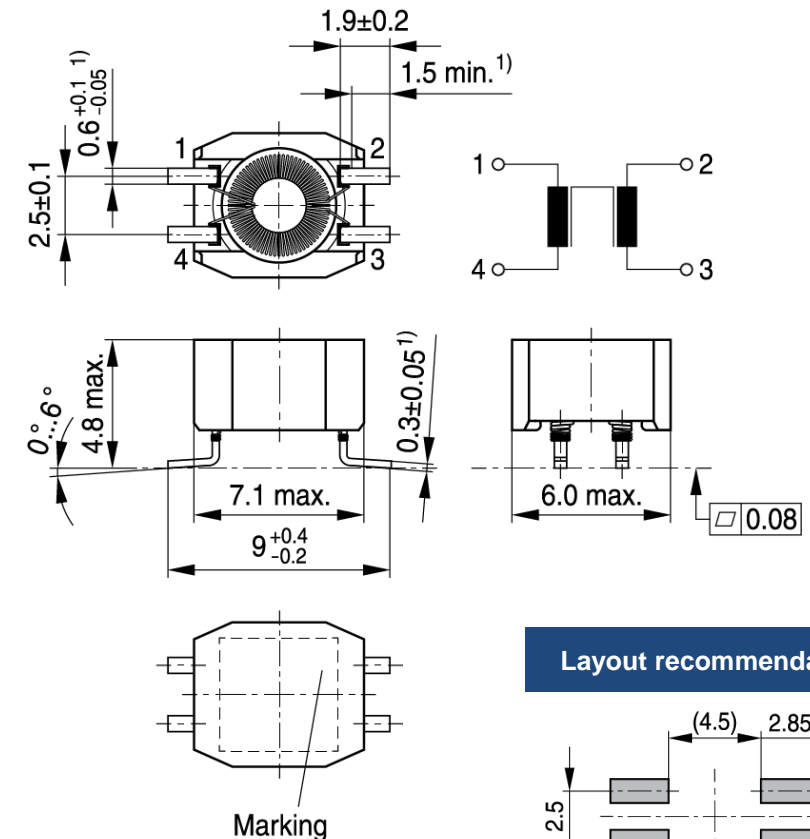

1) Soldering area

Layout recommendation

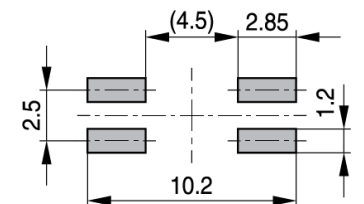

TDK Solutions for 10BASE-T1L (10% droop) Differential Mode Inductors PID*-251M

Features

- Temperature range -40 to +150 °C (incl. self-heating)
- Suitable for lead-free reflow soldering as referenced in JEDEC J-STD 020E
- High rated current with low DC resistance
- Functional isolation up to 500 V

Applications

- Industrial Single Pair Ethernet (SPE)
- Differential mode choke for Power over Data Line (PoDL) for 10BASE-T1L (IEEE 802.3cg-2019)

Technical data

- Rated inductance 250 $\mu\text{H} \pm 20\%$ (per winding)
- PoDL inductance 1000 μH (equivalent inductance when both windings are connected in series (measured in 1-4 with 2-3 shorted))

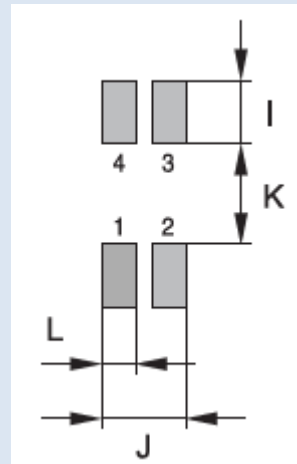

Electrical characteristics and layout recommendation

Part #	Dimension, max [L x W x H, mm]	$R_{DC, typ}$ [Ω]	$I_{Sat, typ}$ [mA]	I_R, typ [mA] (ambient temp.)	I	J	K	L
PID75-251M	7.5 x 7.5 x 4.8	2.25	360	270 (25 °C) 250 (85 °C) 240 (105 °C)	2.1	2.8	3.3	1.1
PID100-251M	10.4 x 10.4 x 6.3	1.13	645	460 (25 °C) 410 (85 °C) 400 (105 °C)	2.4	4.5	5.7	1.7
PID120L-251M	12.5 x 12.5 x 8.5	0.65	910	650 (25 °C) 530 (85 °C) 500 (105 °C)	3.1	5.8	6.8	2.3
PID120H-251M	12.5 x 12.5 x 10.5	0.41	1160	820 (25 °C) 675 (85 °C) 635 (105 °C)	3.1	5.8	6.8	2.3
PID150H-251M	15.5 x 15.5 x 14.5	0.27	1200	1200 (25 °C) 1070 (85 °C) 1040 (105 °C)	4.2	6.6	7.4	2.6

Circuit diagram



DC resistance R_{DC} : Specified per winding
 Saturation current I_{sat} : Based on the inductance decrease (30% below initial value)
 Rated current I_R : Based on the temperature increase (40 K by self-heating); ambient temperature: 25/85/105 °C

TDK Solutions for 10BASE-T1L (10% droop) Differential Mode Inductor PIS150H-471M

Features

- Temperature range -40 to +150 °C (incl. self-heating)
- Suitable for lead-free reflow soldering as referenced in JEDEC J-STD 020E
- High rated current with low DC resistance
- Functional isolation up to 500 V



Applications

- Industrial Single-Pair Ethernet (SPE)
- Differential mode choke for Power over Data Line (PoDL) for 10BASE-T1L (IEEE 802.3cg-2019)

Technical data

- Rated inductance 470 $\mu\text{H} \pm 20\%$ (per winding)

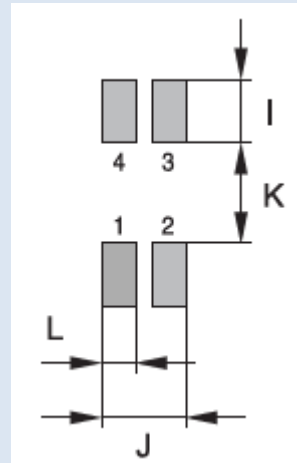

Electrical characteristics and layout recommendation

Part #	Dimension, max [L x W x H, mm]	$R_{DC, typ}$ [Ω]	$I_{Sat, typ}$ [mA]	I_R, typ [mA] (ambient temp.)	I	J	K	L
PIS150H-471M	15.5 x 15.5 x 14.5	0.25	2300	1810 (25 °C) 1650 (85 °C) 1600 (105 °C)	4.2	6.6	7.4	2.6

DC resistance R_{DC} : Specified per winding
 Saturation current I_{sat} : Based on the inductance decrease (30% below initial value)
 Rated current I_R : Based on the temperature increase (40 K by self-heating); ambient temperature: 25/85/105 °C

Circuit diagram



TDK Solutions for 10BASE-T1L (25% droop) Differential Mode Inductors PID*-650M

Features

- Temperature range -40 to +150 °C (incl. self-heating)
- Suitable for lead-free reflow soldering as referenced in JEDEC J-STD 020E
- High rated current with low DC resistance
- Functional isolation up to 500 V

Applications

- Industrial Single-Pair Ethernet (SPE)
- Differential mode choke for Power over Data Line (PoDL) for 10BASE-T1L (IEEE 802.3 cg-2019)

Technical data

- Rated inductance 65 μH $\pm 20\%$ (per winding)
- PoDL inductance 250 μH (equivalent inductance when both windings are connected in series (measured in 1-4 with 2-3 shorted))

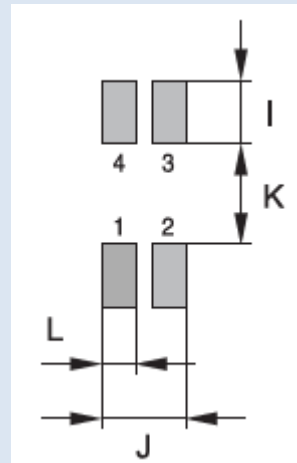

Electrical characteristics and layout recommendation

Part #	Dimension, max [L x W x H, mm]	$R_{DC, typ}$ [Ω]	$I_{Sat, typ}$ [mA]	I_R, typ [mA] (ambient temp.)	I	J	K	L
PID75-650M	7.5 x 7.5 x 4.8	0.53	750	560 (25 °C) 505 (85 °C) 490 (105 °C)	2.1	2.8	3.3	1.1
PID100-650M	10.4 x 10.4 x 6.3	0.30	1200	880 (25 °C) 780 (85 °C) 750 (105 °C)	2.4	4.5	5.7	1.7
PID120L-650M	12.5 x 12.5 x 8.5	0.19	1800	1280 (25 °C) 1160 (85 °C) 1120 (105 °C)	3.1	5.8	6.8	2.3
PID120H S-650M	12.5 x 12.5 x 10.5	0.12	2100	1640 (25 °C) 1450 (85 °C) 1390 (105 °C)	3.1	5.8	6.8	2.3

DC resistance R_{DC} : Specified per winding
 Saturation current I_{sat} : Based on the inductance decrease (30% below initial value)
 Rated current I_R : Based on the temperature increase (40 K by self-heating); ambient temperature: 25/85/105 °C

Circuit diagram



TDK Solutions for 10BASE-T1L (25% droop) Differential Mode Inductors PID*-560M

Features

- Temperature range -40 to +150 °C (incl. self-heating)
- Suitable for lead-free reflow soldering as referenced in JEDEC J-STD 020E
- High rated current with low DC resistance
- Functional isolation up to 500 V

Applications

- Industrial Single-Pair Ethernet (SPE)
- Differential mode choke for Power over Data Line (PoDL) for 10BASE-T1L (IEEE 802.3 cg-2019)

Technical data

- Rated inductance 56 $\mu\text{H} \pm 20\%$ (per winding)
- PoDL inductance 225 μH (equivalent inductance when both windings are connected in series (measured in 1-4 with 2-3 shorted))

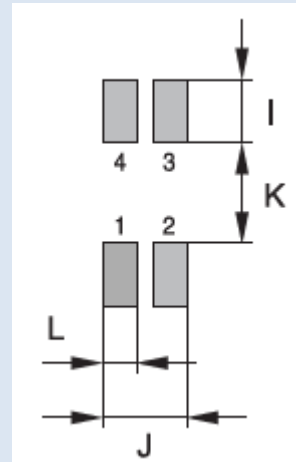

Electrical characteristics and layout recommendation

Part #	Dimension, max [L x W x H, mm]	$R_{DC, typ}$ [Ω]	$I_{Sat, typ}$ [mA]	I_R, typ [mA] (ambient temp.)	I	J	K	L
PID75-560M	7.5 x 7.5 x 4.8	0.48	800	580 (25 °C) 530 (85 °C) 500 (105 °C)	2.1	2.8	3.3	1.1
PID100-560M	10.4 x 10.4 x 6.3	0.28	1350	950 (25 °C) 790 (85 °C) 770 (105 °C)	2.4	4.5	5.7	1.7
PID120L-560M	12.5 x 12.5 x 8.5	0.17	1950	1350 (25 °C) 1200 (85 °C) 1150 (105 °C)	3.1	5.8	6.8	2.3
PID120H S-560M	12.5 x 12.5 x 10.5	0.09	2200	1900 (25 °C) 1740 (85 °C) 1680 (105 °C)	3.1	5.8	6.8	2.3

DC resistance R_{DC} : Specified per winding
 Saturation current I_{sat} : Based on the inductance decrease (30% below initial value)
 Rated current I_R : Based on the temperature increase (40 K by self-heating); ambient temperature: 25/85/105 °C

Circuit diagram



Further Information and Contact

Technical information



- [Data sheets](#)
- [Application note](#)
- [Product Brief & Landing page](#)

Design support



- [Sample kits](#)
- Footprint and 3D files
- Evaluation boards

Get in contact



- [Sales network](#)
- [Product inquiry](#)
- [Social media](#)



For more useful information and to get in contact please visit www.tdk-electronics.tdk.com





www.tdk-electronics.tdk.com