



High-voltage contactor

Gas-filled contactor for high-voltage DC switching

Series/Type:	HVC43-MC
Ordering code:	B88269X*
Date:	2025-01-22
Version:	03

General

The HVC43 series has a robust design for high-voltage DC switching requirements in harsh environments. Our customers deploy the HVC43 series in a wide range of applications such as traction battery systems, and DC fast charging stations.



Features

- Single coil with connector
- No coil termination
- Main terminals without polarity (bi-directional)
- Auxiliary contact is a mirror contact (acc. to IEC 60947-4-1)
- RoHS compatible

Characteristics ¹

Contact arrangement	1A	
Inner contact material	Cu alloy	
Internal contact gap (full disconnection)	2.0 (2 × 1.0)	mm
Recommended connection conductor cross section ²		
- for I _{th} = 150 A DC	≥ 50	mm ²
- for I _{th} = 200 A DC	≥ 60	mm ²
- for I _{th} = 250 A DC	≥ 60	mm ²
Vibration in closed state, xyz axis ³		
Shock, 6 ms ½ sine, peak ⁴	588	m/s ²
Vibration, sine 100 ... 2000 Hz, peak ⁵	98	m/s ²
Wideband random vibration, 10 ... 1000 Hz ⁶	49	m/s ² _{RMS}
Operation and storage ⁷		
Temperature	-40 ... +85	°C
Humidity	5 ... 85	%
Air pressure	60 ... 106	kPa
Utilization category	IEC 60947-4-1	DC-1
Pollution degree	IEC 60947-1	2
IP level	IEC 60529	IP 40
Climatic category	IEC 60068-1	40/085/21
Certifications	CCC UKCA CE UL 60947-4-1 (E491412)	
Weight ⁸	~ 300	g

See "Notes" on page 9

Specification ⁹

Type HVC43-...	150A	200A	250A	
Contact				
Maximum operating voltage	1000			V DC
Continuous current I_{th}	150	200	250	A DC
Temporary overcurrent (10 min) I_{CW1}	260	290	320	A DC
Temporary overcurrent (1 min) I_{CW2}	440	480	540	A DC
Rated operational voltage ^{10, 11} U_e	1000			V DC
Rated operational current ^{10, 11} I_e	60			A DC
Contact resistance at 100 A DC				
- typical	0.125			mΩ
- max.	0.25			mΩ
Insulation resistance at 1000 V DC				
- contact to contact / contact to coil	≥ 1			GΩ
Dielectric strength ¹²				
- contact to contact / contact to coil	≥ 4400			V AC
Rated impulse withstand voltage ¹³ U_{imp}	8			kV
Operating time ¹⁴				
- make	≤ 30			ms
- break	≤ 15			ms
Electrical endurance ^{11, 15, 16}				
Mechanical ¹⁷				
- max. 1 V, 1 A DC (make & break)	350000			operations
Capacitive				
- at 20 V DC, 140 A DC (make)	70000			operations
Resistive				
- at 450 V DC, 200 A DC (make & break)	1000			operations
- at 450 V DC, 250 A DC (break) ¹⁸	550			operations
Maximum cut-off ¹⁹				
- at 450 V DC, 2000 A DC (break) ²⁰	1			operation
- at 1000 V DC, 450 A DC (break) ²¹	1			operation
Coil type ¹⁵	12 V	24 V		
Rated control voltage (nominal) U_c	12	24		V DC
Operating voltage range $U_1 \dots U_2$	9 ... 16	18 ... 32		V DC
Pick-up voltage (max.) U_1	9	18		V DC
Drop-out voltage (min.)	1	2		V DC
Minimum holding current	0.16	0.08		A DC
Power at nominal voltage ²²	5.8	5.8		W
Nominal resistance	24	96		Ω
Auxiliary contact				
Operating voltage range	1...24			V DC
Min. operating current	1			mA DC
Max. operating current	1			A DC
Max. resistance	500			mΩ

See "Notes" on page 9

Characteristics 11, 15, 16, 23

**Estimated make & break life curves
for resistive loads**

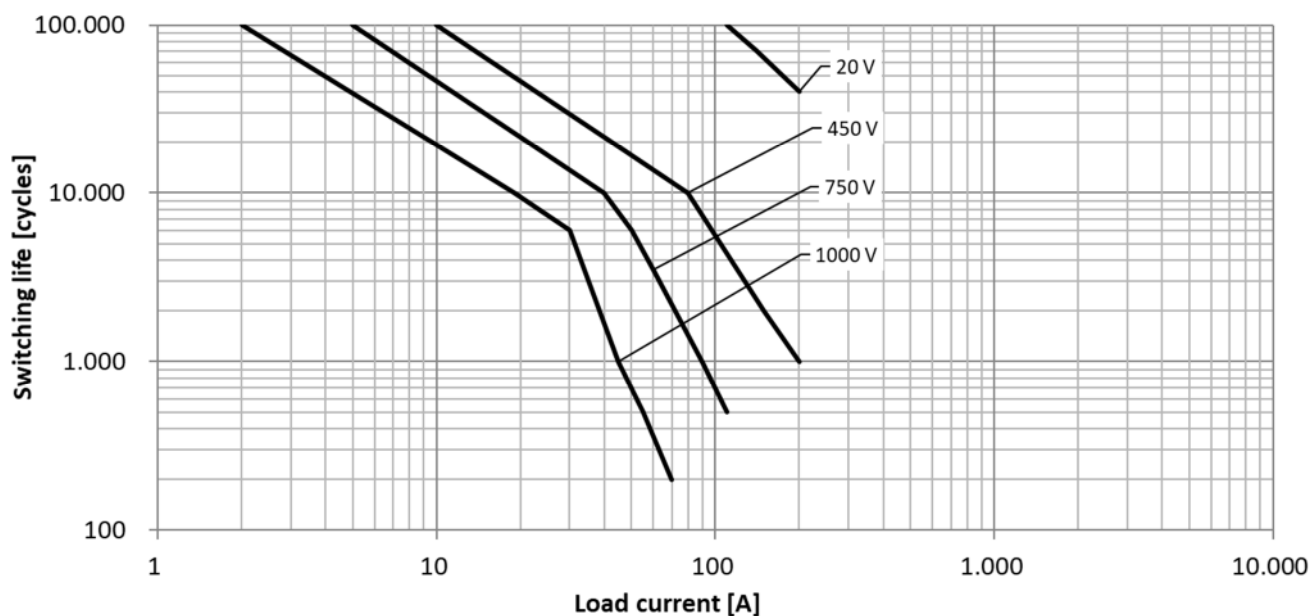

**Estimated break-only life curves
for resistive loads**

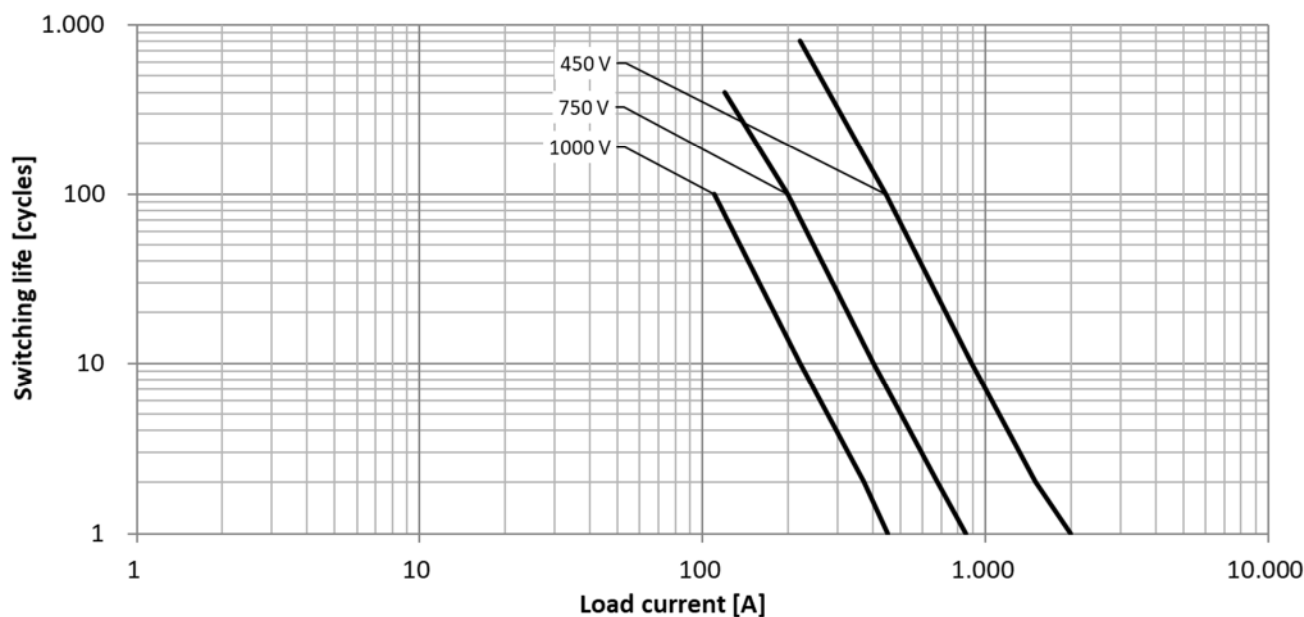

See "Notes" on page 9

Current handling capability
at 85 °C

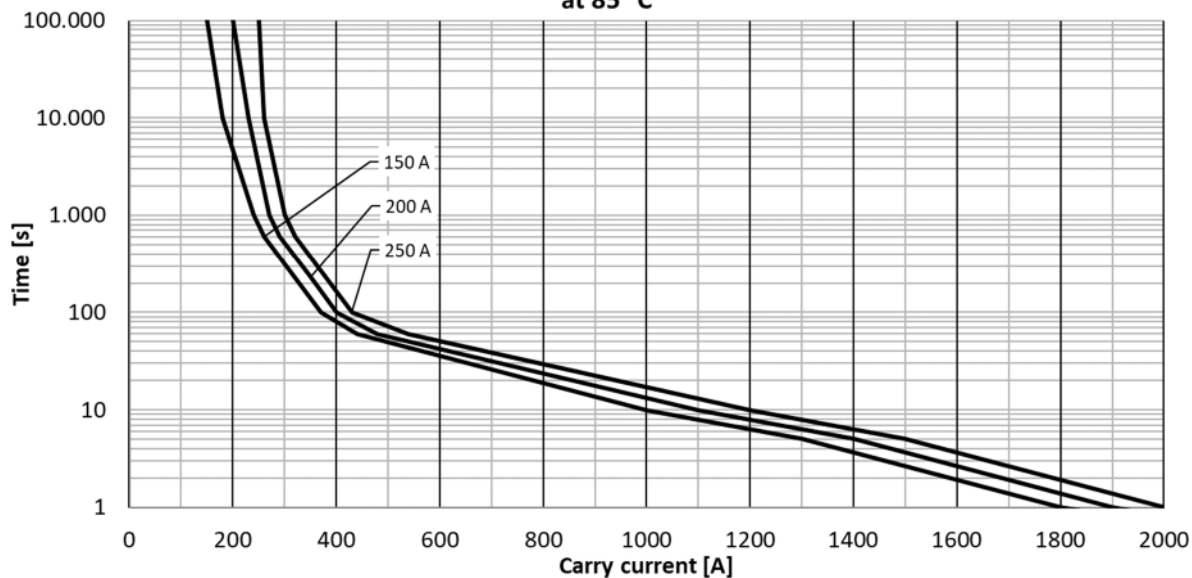

Typical operating voltage characteristics
12 V coil

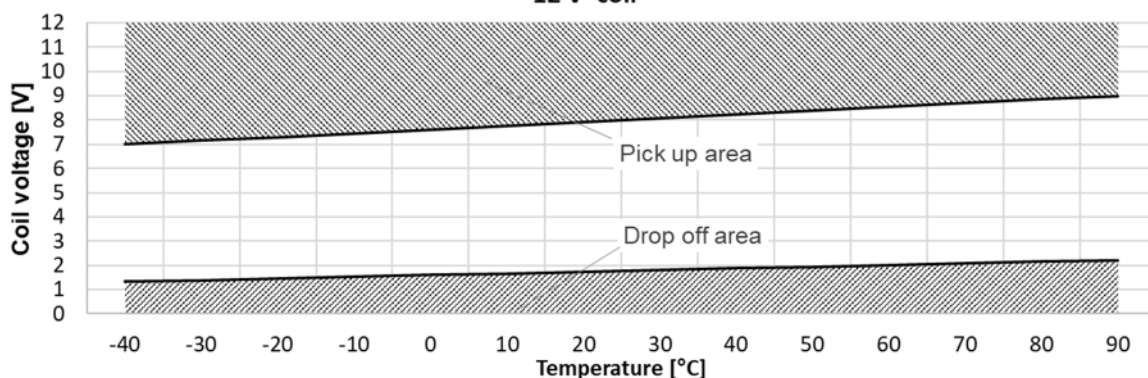

Typical operating voltage characteristics
24 V coil

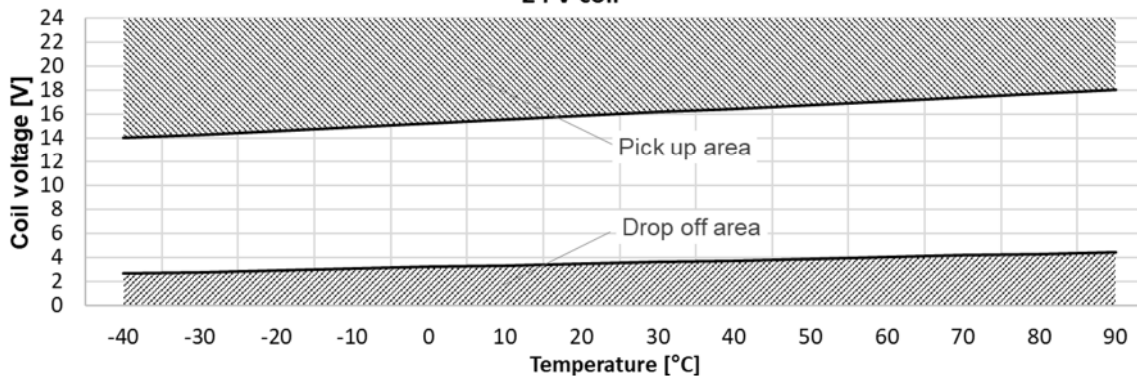

Dimensional drawings

in mm

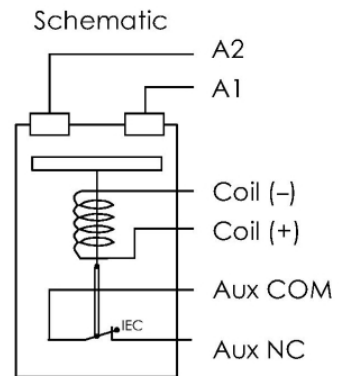
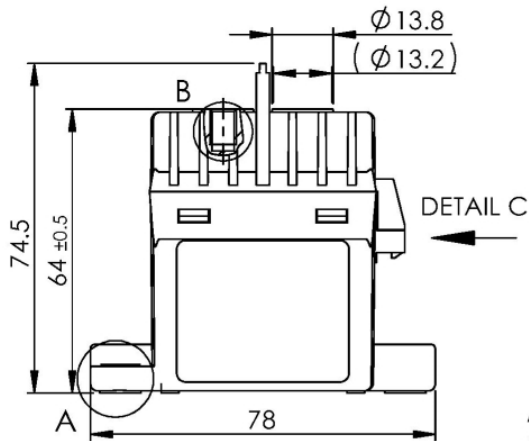
Accessory:

Micro-Fit 3.0 connector (Molex 436450400)

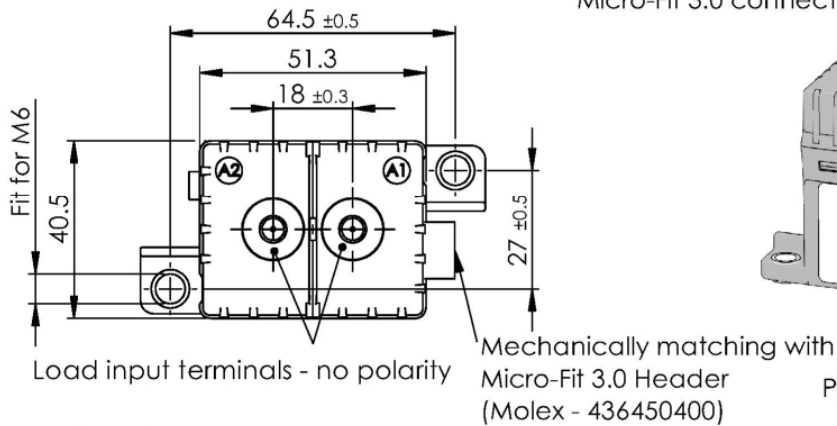
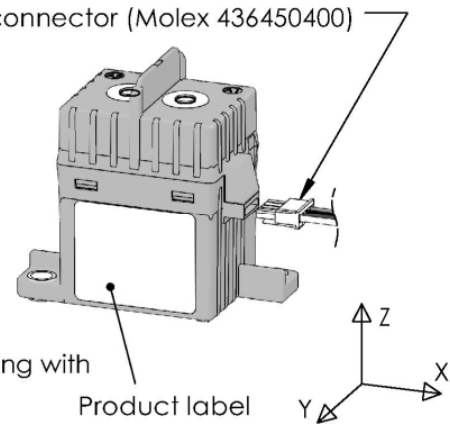
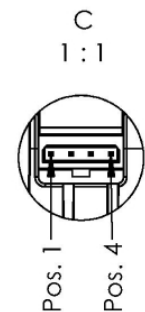
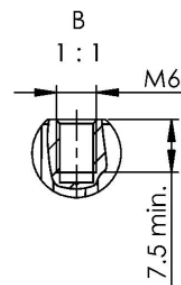
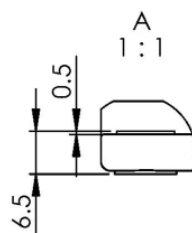
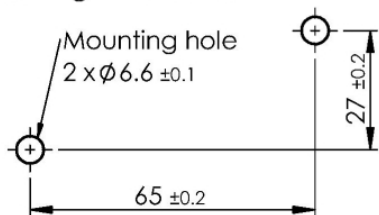
Mounting dimensions:

In case of no tolerance shown in dimensional drawing, general tolerances apply:
 dimension ≤ 10 mm: ± 0.3 mm; dimension 10 to 50 mm: ± 0.6 mm; dimension > 50 mm: ± 1 mm

Installation information

Connection name	Type	Marking	Finishing	Remarks
A1	Main terminal M6	A1	Copper contact surface	Max. screw ingress depth 7.5 mm, tightening torque 6...8 Nm
A2	Main terminal M6	A2		
Coil (+)	Coil terminal	Pos. 2	Micro-fit 3.0 (Molex)	Max. allowable pull force 10 N
Coil (-)	Coil terminal	Pos. 3		
Aux COM	Auxiliary contact	Pos. 1		
Aux NC	Auxiliary contact	Pos. 4		
Housing mounting	Contactor mounting M6	None	Stainless steel insert	Tightening torque 4...6 Nm

Important:

Coil terminations should be suppressed with a surge protection device. Preferably a varistor (e.g. S10K30, B72210S0300K101 or equivalent) should be installed in parallel, see "Cautions and warnings". If an alternative coil suppression device is used, the clamping voltage must not be smaller than 50 V.

Auxiliary contacts NC and COM are normally closed.

When the contacts are open and the coil voltage is "0 V", the part is stuck.

Auxiliary contact

Example circuit to realize stuck detection:

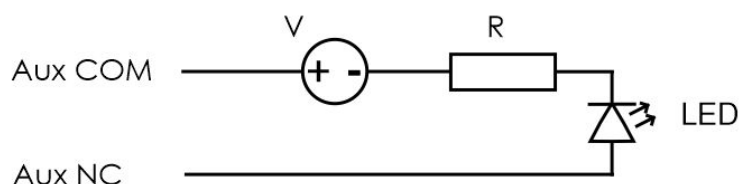

The LED will be ON when the contactor is OFF.

In case the contactor is stuck, the Aux COM and Aux NC contacts will remain open, hence the circuit is open, and the LED will be off, indicating the malfunction. The resistance R must be selected in a way that the minimum and maximum current ratings are not exceeded.

High-voltage contactor

B88269X*

Gas-filled contactor for high-voltage DC switching

HVC43-MC

Packing unit

B88269X...C011 = 1 pc. in cardboard box

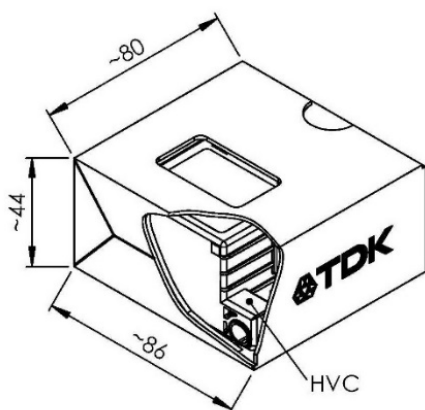

Delivery unit

10 pcs. in cardboard box

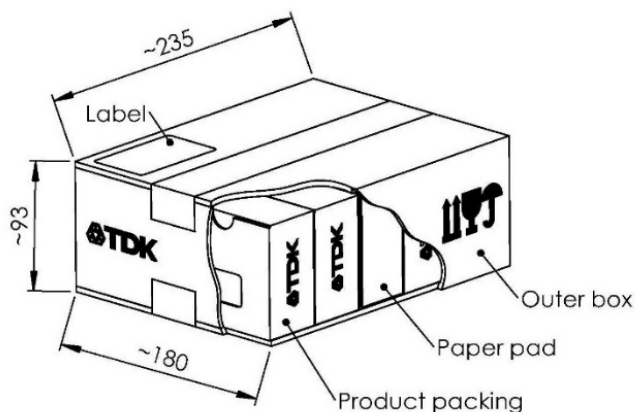

Nomenclature of type name

Example (other digits may indicate customized version or special option)

HVC 43 – 150 A – 12 MC

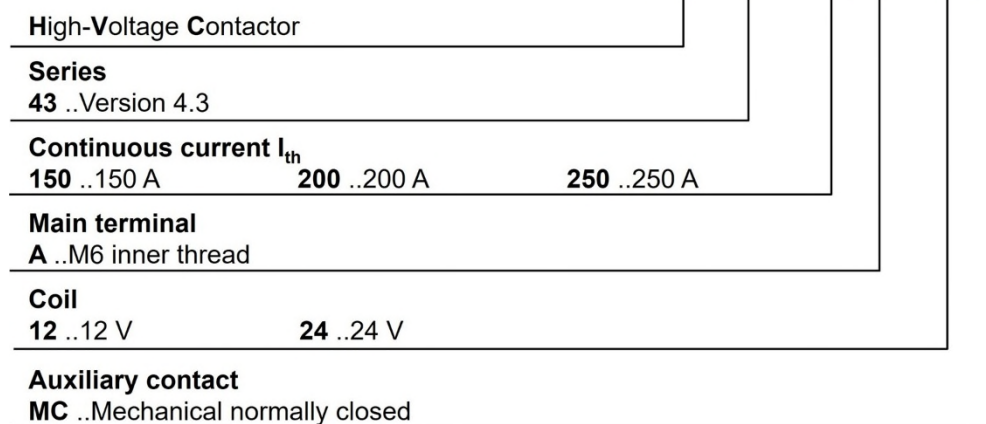

Ordering codes

Continuous current A DC	Coil voltage V DC	Type name	Ordering code *
150	12	HVC43-150A-12MC	B88269X7290C011
	24	HVC43-150A-24MC	B88269X7320C011
200	12	HVC43-200A-12MC	B88269X7300C011
	24	HVC43-200A-24MC	B88269X7330C011
250	12	HVC43-250A-12MC	B88269X7310C011
	24	HVC43-250A-24MC	B88269X7340C011

* The ordering code can be followed by a three-digit internal suffix

Accessory

Mating connector plug (similar to Molex-436450400)

To order if required:

Ordering code **B88269X9970C101** = 10 pcs. or **B88269X9970C102** = 100 pcs. in a box

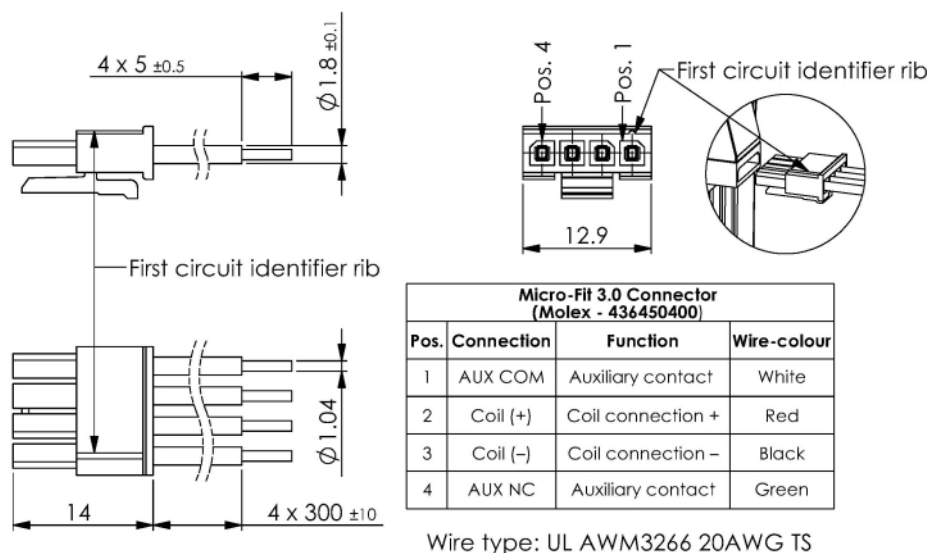

Notes:

- 1 All physical dimensions specified in the datasheet follow the general tolerances of the datasheet drawing.
- 2 The recommended cross section refers to pure copper. In other cases it must be matched to actual current, conductor material properties and operation temperature.
- 3 Detection time 10 μ s: micro-openings \leq 10 μ s may occur between main contacts.
- 4 Referring to IEC 60068-2-27.
- 5 Referring to IEC 60068-2-6.
- 6 Referring to IEC 60068-2-64.
- 7 Freezing or condensing must be avoided.
- 8 Valid for base-model without accessory, other configurations will lead to deviations.
- 9 The specified values apply to unused contactors acc. to IEC 61810-1.
- 10 Referring to IEC 60947-4-1, 6000 operations make & break.
- 11 Referring to IEC 60947-4-1, 50% of operations in positive and 50% in negative direction.
- 12 Detection limit 10 mA.
- 13 Referring to IEC 60947-4-1.
- 14 Measured at rated control voltage U_c including contact bouncing time.
- 15 Specified referring to JIS C 5442 (temperature 15 $^{\circ}$ C to 35 $^{\circ}$ C, humidity 25% to 85% RH).
- 16 End of life is reached when insulation resistance is $<$ 50 M Ω at 1000 V.
- 17 Duty cycle 50%, cycle duration 1 s, value represents B10 lifetime acc. to Weibull analysis.
- 18 Duty cycle 1%, cycle duration 600 s.
- 19 No fire and no explosion will occur after this break.
- 20 Tested with resistive loads with $\tau \leq$ 1 ms.
- 21 Tested for maximum break at 1000 V, 450 A with $\tau \leq$ 0.3 ms.
- 22 Tolerance \pm 10% at thermal equilibrium
- 23 For "make & break life curves" duty cycle is 10% and cycle duration is 6 s. For "break-only life curves" duty cycle is 1% and cycle duration is 600 s.

Cautions and warnings

- It is not allowed to use the contactor outside of the parameter range specified in this data sheet. This also includes temperature and humidity. Overloading may destroy the component.
- It must be ensured that during usage, storage or transportation, direct sunlight is avoided. The ambient temperature during usage must not exceed the value specified in this data sheet.
- This contactor is not waterproof.
- The manufacturer cannot be held liable for failures caused by condensation or icing. The customer must apply suitable measures to avoid these circumstances.
- It is forbidden to use this contactor in atmospheres loaded with organic solvents (alcohol, petroleum, etc.) or strong alkaline substances (ammoniac, acids in general, etc.).
- We strongly recommend implementing redundancy, taking measures to prevent the spread of fire, taking the possibilities of malfunction into account and performing regular maintenance.
- Contactors must be handled with care and must not be dropped.
- Contactors radiate magnetic and electromagnetic fields. Please ensure that other components mounted in proximity are not affected.
- This contactor is tested and classified according to UL as an open-type device. This means that the contactor is intended to be installed in an ultimate enclosure provided by a third party. Furthermore, the contactor coil circuit is intended to be powered with a Class 2 source.
- The contactor must be mounted onto a flat surface using the designated fixation holes in addition to the cable lugs or busbars attached to the main connection terminals. It is not allowed to mount the contactor using only busbars.
- The contactor must be mounted in a way that the vertical axis of the part (Z-axis) is not in line with the main shock axis of the application. Still, it must be mounted either upright standing or horizontal lying on either side. Upside down mounting must be avoided. Only the original mounting holes are allowed to be used to mount the part.
- In case two contactors are mounted in proximity, a clearance distance of 10 mm must be kept.
- It is forbidden to attach any kind of additional construction to or on the contactor.
- During installation and operation of the contactor, it must be ensured that no foreign matter adheres to the main connection terminals. Especially oils and silicones must be avoided.
- The cable lugs or busbars to the main contacts must be securely tightened. Otherwise, current stress may generate sparks and heating. Use only suitable tightening material (screws, bolts or nuts) for all mechanical connections to the contactor and verify their functionality in the application. The torque range recommended in the data sheet is suitable for multiple fixation; the maximum torque is suited for one time fixation only.
- Attached wires and plugs are not allowed to be used for lifting and handling the part (maximum allowed pull-force is 10 N).
- It is required to always use a suitable backup fuse for the contactor.
- Contactors may become hot during extended periods of current overload (burn hazard).
- The main connections of the contactor act as a heat sink. Please ensure that the connection surface area is fully covered with a matched cable lug or busbar and that the connection hole in the cable lug or busbar is according to DIN ISO 20273 (middle clearance).
- For continuous high current operation, make sure that the temperatures of the connection terminals do not exceed 130 °C by selecting an appropriate cable or busbar cross section, or active cooling.

- Switching capacitive loads can lead to high inrush currents and can cause welding of the main connections (tack-welding). These inrush currents need to be limited as much as possible. Even short inrush currents in the microsecond range can lead to tack-welding. Please ensure with appropriate pre-charging that the differential voltage across the main terminals is as low as possible when closing the contactor. Any connected capacitances should be pre-charged to a minimum of 98% (5 time constants).
- In the event of a break under inductive load, the voltage at the connection terminals must not exceed the nominal operating voltage by more than 10%. Break of inductive loads with time constant greater than 1 ms will shorten the lifetime. Failure may also occur.
- The contactor is bi-directional (no polarity of main connections). The service life is estimated based on the requirements of IEC 60947-4-1 Chapter 8.2.4, where 50% of the operations are performed in positive direction and 50% in negative direction.
- After long-term operation, the contactor coil resistance is increased due to the temperature rise. If the contactor is switched on immediately afterwards, the coil characteristics may be deteriorated.
- In the event of a current exceeding the maximum breaking current by more than 50% or triggering a series fuse, the contactor must be considered damaged and replaced.
- The lifetime depends on several factors like e.g. load type, driving circuit and ambient conditions. We recommend checking the performance of the part under actual conditions.
- Simultaneously applied maximum operation parameters for e.g. coil voltage, over currents, temperature, vibration etc. may lead to reduced lifetime. We recommend applying rated settings to achieve optimum life performance.
- The contactor must not be operated without any load. This may increase the contact resistance.
- The operating life of the contactor can be affected by strong magnetic fields. Please ensure that there are no magnetic field sources in proximity and avoid nearby installed heat sources.
- We recommend separating or shielding the low voltage side (coil and auxiliary connections if available) from the high voltage side (main connection terminals).
- The coil input voltage needs to be kept stable and without disturbances. It should always remain above the minimum value of the coil voltage operation range specified in the datasheet.
- For a successful pick-up, the coil voltage cannot be ramped up slowly. It needs to be applied instantly (within less than 1 ms) to at least the maximum pick-up voltage. For a successful breaking, the coil voltage cannot be ramped down slowly. It needs to be switched off instantly (within less than 1 ms).
- The contactor is not intended to be used with pulse width modulation (PWM) controllers. Please contact TDK for details.
- To protect the coil contacts from overvoltage when switching off, a protection device needs to be installed in parallel to the coil.
- The normally closed auxiliary contact is a mirror contact acc. to IEC 60947-4-1 Annex F.
- During vibration in the unpowered state of the contactor, the auxiliary contact may be displaced from its resting position. The resulting short interruptions of the auxiliary contact do not necessarily indicate closing of the main contact.

High-voltage contactor

B88269X*

Gas-filled contactor for high-voltage DC switching

HVC43-MC

Display of ordering codes for TDK Electronics products

The ordering code for one and the same product can be represented differently in data sheets, data books, other publications, on the company website, or in order-related documents such as shipping notes, order confirmations and product labels. **The varying representations of the ordering codes are due to different processes employed and do not affect the specifications of the respective products.** Detailed information can be found on the Internet under www.tdk-electronics.tdk.com/orderingcodes.

Important notes

The following applies to all products named in this publication:

1. Some parts of this publication contain **statements about the suitability of our products for certain areas of application**. These statements are based on our knowledge of typical requirements that are often placed on our products in the areas of application concerned. We nevertheless expressly point out **that such statements cannot be regarded as binding statements about the suitability of our products for a particular customer application**. As a rule we are either unfamiliar with individual customer applications or less familiar with them than the customers themselves. For these reasons, it is always ultimately incumbent on the customer to check and decide whether a product with the properties described in the product specification is suitable for use in a particular customer application.
2. We also point out that **in individual cases, a malfunction of electronic components or failure before the end of their usual service life cannot be completely ruled out in the current state of the art, even if they are operated as specified**. In customer applications requiring a very high level of operational safety and especially in customer applications in which the malfunction or failure of an electronic component could endanger human life or health (e.g. in accident prevention or life-saving systems), it must therefore be ensured by means of suitable design of the customer application or other action taken by the customer (e.g. installation of protective circuitry or redundancy) that no injury or damage is sustained by third parties in the event of malfunction or failure of an electronic component.
3. **The warnings, cautions and product-specific notes must be observed.**
4. In order to satisfy certain technical requirements, **some of the products described in this publication may contain substances subject to restrictions in certain jurisdictions (e.g. because they are classed as hazardous)**. Useful information on this will be found in our Material Data Sheets on the Internet (www.tdk-electronics.tdk.com/material). Should you have any more detailed questions, please contact our sales offices.
5. We constantly strive to improve our products. Consequently, **the products described in this publication may change from time to time**. The same is true of the corresponding product specifications. Please check therefore to what extent product descriptions and specifications contained in this publication are still applicable before or when you place an order.

We also **reserve the right to discontinue production and delivery of products**. Consequently, we cannot guarantee that all products named in this publication will always be available. The aforementioned does not apply in the case of individual agreements deviating from the foregoing for customer-specific products.

6. Unless otherwise agreed in individual contracts, **all orders are subject to our General Terms and Conditions of Supply**.
7. **Our manufacturing sites serving the automotive business apply the IATF 16949 standard**. The IATF certifications confirm our compliance with requirements regarding the quality management system in the automotive industry. Referring to customer requirements and customer specific requirements ("CSR") TDK always has and will continue to have the policy of respecting individual agreements. Even if IATF 16949 may appear to support the acceptance of unilateral requirements, we hereby like to emphasize that **only requirements mutually agreed upon can and will be implemented in our Quality Management System**. For clarification purposes we like to point out that obligations from IATF 16949 shall only become legally binding if individually agreed upon.

Important notes

8. The trade names EPCOS, CarXield, CeraCharge, CeraDiode, CeraLink, CeraPad, CeraPlas, CSMP, CTVS, DeltaCap, DigiSiMic, FilterCap, FormFit, InsuGate, LeaXield, MediPlas, MiniBlue, MiniCell, MKD, MKK, ModCap, MotorCap, PCC, PhaseCap, PhaseCube, PhaseMod, PhiCap, PiezoBrush, PlasmaBrush, PowerHap, PQSine, PQvar, SIFERRIT, SIFI, SIKOREL, SilverCap, SIMDAD, SiMic, SIMID, SineFormer, SIOV, SurfIND, ThermoFuse, WindCap, XieldCap are **trademarks registered or pending** in Europe and in other countries. Further information will be found on the Internet at www.tdk-electronics.tdk.com/trademarks.

Release 2024-02