

8533 Series



Applications

Engine area/sensors in harsh environments, railways (brake system), for all purposes in severe climatical environment and high temperature.

Standards

NFL 54143 - EN 2997



Description

- Screw coupling
- Interchangeable and intermateable with MIL-C 83723 Series III T type
- Plug with self locking system
- High temperature connector
- High level shock and vibration
- Thermocouple contacts available except hermetic connectors.

Characteristics

Mechanical

- Shell : aluminum alloy (class R-W-A) stainless steel (class K, E, Y and YE)
- Plating : nickel (class R)
 - olive green cadmium (class W)
 - black anodized (class A)
 - passivated (class K, E, Y and YE)
- Insulator : thermoset
- Grommet and seal : silicone elastomer
- Contact : copper alloy ferrous alloy (class Y and YE)
- Plating : gold over nickel
- Mechanical endurance :
 - 250 operations (class R and W)
 - 500 operations (class K, E, Y and YE)
- Shock : 300 g during 3 ms
- Vibration : random 5 Hz to 2000 Hz - 1 G²/Hz (2x8 hours)
- Contact retention :
 - size 20 : 90 N
 - size 16 : 111 N
 - size 12 : 133 N

Electrical

- Dielectric withstanding

Altitude	Service
At ground	1500 Vrms
15 000 m	600 Vrms
21 000 m	400 Vrms
33 000 m	200 Vrms

- Contact resistance : as per NFL 54143 and EN 2997
- Insulation resistance : > 5000 MΩ at 500 Vdc
- Max current rating per contact :

size 20 : 7.5 A	size 20 : 5 A	} class Y and YE
size 16 : 13 A	size 16 : 10 A	
size 12 : 23 A	size 12 : 17 A	
- Electrical continuity :
 - 5 mΩ with RFI shielded
 - 60 mΩ without RFI shielded
- Shielding : to 100 MHz at 1 GHz attenuation > 65 dB

Climatic

- Working temperature :
 - 65°C to 175°C (class W)
 - 65°C to 200°C (class R, A, K and Y)
 - 65°C to 260°C cyclic (class E and YE)
- Leakage : low pressure immersion - L54001 and interfacial sealing : pressure 2kPa
- Hermeticity : differential pressure of 1 bar (air helium) leakage is ≤ 0,36 mm³/hr
- Damp heat : as per NFL 54143 and EN 2997
 - 10 cycles of 24 hours
- Salt spray : 48 hours (class R-K-E-Y and YE) 500 hours (class W)
- Fire resistance : as per NFL 54143 and EN 2997 (class K and E)

Resistance to fluids

MIL-H 5606 - SKYDROL 500 B4 - LD4
 JP5 - MIL-L 7870 A - MIL-L 23699
 MIL-L 7808 - MIL-C 25769 - MIL-A 8243

Ordering information

Environmental connectors

basic series	8533 - 0 R S 14 - 15 P N •						
shell type	0 - square flange receptacle 7 - jam nut receptacle 3 - plug with self locking and RFI shielding 4 - plug with self locking						
class	W - 175°C (aluminum version with olive green cadmium plating) R - 200°C (aluminum version with nickel plating) A - 200°C (aluminum version with black anodized plating) K - 200°C (stainless steel version) E - 260°C (stainless steel version) S - with 360° teeth						
shell size	- 08-10-12-14-16-18-20-22-24-26-28						
contact layouts	- see table p 243						
contact type	P - male S - female						
polarization	- N-6-7-8-9-Y - see p 244						
specification	without specification - connector supplied with standard contacts 08 - connector supplied with large barrel contacts L - connector supplied without contacts						



8533 Series

Backshells

aluminum version

basic series		852 - 31	N	14
backshell type	31 - backnut 52 - straight cable clamp 51 - elbow cable clamp			
plating	N - nickel A - black anodized W - olive green cadmium			
shell size	- 08-10-12-14-16-18-20-22-24			

Backshells

stainless steel version

basic series		8527 - 01	14	•
backshell type	01 - backnut 02 - straight cable clamp			
shell size	- 08-10-12-14-16-18-20-22-24			
specification	A - obligatory suffix for backshell type 02 only			

NOTE : for others types and sizes backshells - See catalogue M 85049

Hermetic connectors

basic series		8533 - 1	Y	10 - 05	P	N
shell type	1 - solder fixing receptacle 2 - square flange receptacle 7 - jam nut receptacle					
class	Y - 200° YE - 260°					
shell size	- 08-10-12-14-16-18-20*-22-24*					
contact layouts	see table p 243					
contact type	P - male only					
polarization	see table p 244					

* Consult us

Protective caps

aluminum version

basic series		83723 - 21	R	14
cap type	21 - cap for receptacle 22 - cap for plug			
plating	R - nickel W - olive green cadmium A - black anodized			
shell size	- 08-10-12-14-16-18-20-22			

8533 Series



Cross reference list

Souriau	EN 2997 NFL 54143 (1)	AEROSPATIALE	ROLLS ROYCE	Description		
852-31 **	-	ASN-E0455-01 ** N	-	Aluminum version	Backnut	
852-52N **	-	ASN-E0455-02 ** N	-		Straight cable clamp	
852-51N **	-	ASN-E0455-03 ** N	-		Elbow cable clamp	
8527-01 **	-	ASN-E0199-01 ** K	-	Stainless steel version	Backnut	
8527-02 ** A	-	ASN-E0199-02 ** K	-		Straight cable clamp	
8526-1348	EN 3155-018 M 2020	-	-	Class 175° C and 200° C	Male	Standard size 20
8526-1349	EN 3155-018 M 1616	NSA 938 151 PA 1600	-			Standard size 16
8526-1350	EN 3155-018 M 1212	NSA 938 151 PA 1200	-			Standard size 12
8522-2349A	EN 3155-018 M 2018	NSA 938 151 PA 2000	-			Large barrel size 20
8522-6179A	EN 3155-018 M 1614	NSA 938 151 PA 1601	-			Large barrel size 16
8526-4175	EN 3155-018 M 1618	NSA 938 151 PA 1602	-		Small barrel size 16	
8526-5041	EN 3155-018 M 1218	NSA 938 151 PA 1202	-		Small barrel size 12	
8526-1344	EN 3155-019 F 2020	-	-		Female	Standard size 20
8526-1346	EN 3155-019 F 1616	NSA 938 152 SA 1600	-			Standard size 16
8526-1347	EN 3155-019 F 1212	NSA 938 152 SA 1200	-			Standard size 12
8520-292	EN 3155-019 F 2018	NSA 938 152 SA 2000	-	Large barrel size 20		
8522-6180A	EN 3155-019 F 1614	NSA 938 152 SA 1601	-	Large barrel size 16		
8526-4176	EN 3155-019 F 1618	NSA 938 152 SA 1602	-	Small barrel size 16		
8526-5591	EN 3155-019 F 1218	NSA 938 152 SA 1202	-	Small barrel size 12		
8533-1000	EN 3155-004 M 2020	-	ESC30 P20 BC	Contact	Male	Standard size 20
8533-1004	EN 3155-004 M 1616	ASN-E 0445 FW 1600	ESC30 P16 BC			Standard size 16
8533-1002	EN 3155-004 M 2018	ASN-E 0445 FW 2001	-			Large barrel size 20
8533-1006	EN 3155-004 M 1614	ASN-E 0445 FW 1601	-			Large barrel size 16
8533-1008	EN 3155-004 M 1618	ASN-E 0445 FW 1602	-		Small barrel size 16	
8533-1035	EN 3155-004 M 1212	ASN-E 0445 FW 1200	ESC30 P12 BC		Small barrel size 1	
8533-1019	EN 3155-044 M 2022	-	-		Double crimping size 20	
8533-1011 900	EN 3155-005 F 2020	-	ESC30 S20 BC		Class 260° C	Female
8533-1012 900	EN 3155-005 F 1616	ASN-E 0446 DW 1600	ESC30 S16 BC	Standard size 16		
8533-1003	EN 3155-005 F 2018	ASN-E 0446 DW 2001	-	Large barrel size 20		
8533-1007	EN 3155-005 F 1614	ASN-E 0446 DW 1601	-	Large barrel size 16		
8533-1009	EN 3155-005 F 1618	ASN-E 0446 DW 1602	-	Small barrel size 16		
8533-1036	EN 3155-005 F 1212	ASN-E 0446 DW 1200	ESC30 S12 BC	Standard size 12		
8533-1018	EN 3155-045 F 2022	-	-	Double crimping size 20		
8533KE3C**	EN2997KE3C**	-	-	Stainless steel version		Projective caps receptable

8533 Series



Cross reference list

Souriau	EN 2997 NLF 54143 (1)	AEROSPATIALE	BOEING BACC 63 CN/CM	BOEING BACC 63 BR/BT ⁽²⁾	ROLLS ROYCE	Description
8533-0RS ... P S 08 ⁽³⁾	-	ASN-E0454RS ... P S	-	-	-	Square flange receptacle
8533-0WS ... P S 08 ⁽³⁾	-	-	-	-	-	
8533-0RS ... P S	EN2997-RS0 ... M F	-	-	-	-	
8533-0WS ... P S	EN2997-WS0 ... M F	-	-	-	-	
8533-0RS ... P S L	EN2997-RS0 ... A B	ASN-E0454RS ... P S A	-	-	-	
8533-0WS ... P S L	EN2997-WS0 ... A B	-	-	-	-	
8533-3RS ... P S 08 ⁽³⁾	-	ASN-E0452RS ... P S	-	-	-	Plug with self locking and RFI shielded
8533-3WS ... P S 08 ⁽³⁾	-	-	-	-	-	
8533-3RS ... P S	EN2997-RS6 ... M F	-	-	-	-	
8533-3WS ... P S	EN2997-WS6 ... A B	-	-	-	-	
8533-3RS ... P S L	EN2997-RS6 ... A B	ASN-E0452RS ... P S A	-	-	-	
8533-3WS ... P S L	EN2997-WS6 ... A B	-	-	-	-	
8533-4RS ... P S 08 ⁽³⁾	-	ASN-E0451R ... P S	-	-	-	plug with self locking
8533-4WS ... P S 08 ⁽³⁾	-	-	-	-	-	
8533-4RS ... P S	EN2997-R6 ... M F	-	-	-	-	
8533-4WS ... P S	EN2997-W6 ... M F	-	-	-	-	
8533-4RS ... P S L	EN2997-R6 ... A B	ASN-E0451R ... P S A	-	-	-	
8533-4WS ... P S L	EN2997-W6 ... A B	-	-	-	-	
8533-0KS ... P S 08 ⁽³⁾	-	-	-	-	-	square flange receptacle
8533-0KS ... P S	EN2997-S0 ... M F	-	-	-	-	
8533-0KS ... P S L	EN2997-S0 ... A B	-	-	-	-	
8533-3KS ... P S 08 ⁽³⁾	-	-	-	-	-	plug with self locking and RFI shielded
8533-3KS ... P S	EN2997-S6 ... M F	-	-	-	-	
8533-3KS ... P S L	EN2997-S6 ... A B	-	-	-	-	
8533-4KS ... P S 08 ⁽³⁾	-	-	-	-	-	plug with self locking
8533-4KS ... P S	EN2997-K6 ... M F	-	-	-	-	
8533-4KS ... P S L	EN2997-K6 ... A B	-	-	-	-	
8533-1Y ... P	EN2997-Y1 ... M	-	-	-	-	solder fixing receptacle square flange hermetic receptacle jam nut hermetic receptacle
8533-2Y ... P	EN2997-Y0 ... M	-	-	-	-	
8533-7Y ... P	EN2997-Y7 ... M	-	-	-	-	
8533-0ES ... P S 08 ⁽³⁾	-	ASN-E0444SE ... P S	-	-	-	square flange receptacle
8533-0ES ... P S	EN2997-SE0 ... M F	-	-	BACC63BT ... P S A	-	
8533-0ES ... P S L	EN2997-SE0 ... A B	ASN-E0444SE ... P S A	BACC63CN ... P S	BACC63BT ... P S	ESC10KE0 ... P S	
8533-3ES ... P S 08 ⁽³⁾	-	ASN-E0442SE ... P S	-	-	-	plug with self locking and RFI shielded
8533-3ES ... P S	EN2997-SE6 ... M F	-	-	BACC63BR ... P S A	-	
8533-3ES ... P S L	EN2997-SE6 ... A B	ASN-E0442SE ... P S A	BACC63CM ... P S	BACC63BR ... P S	ESC10SE6 ... P S	
8533-4ES ... P S 08 ⁽³⁾	-	ASN-E0441KE ... P S	-	-	-	plug with self locking
8533-4ES ... P S	EN2997-KE6 ... M F	-	-	-	-	
8533-4ES ... P S L	EN2997-KE6 ... A B	ASN-E0441KE ... P S A	-	-	ESC10KE6 ... P S	
8533-KE5 ..	EN2997-KE5 ..	-	-	-	-	dummy receptacle
8533-1YE ... P	EN2997-YE1 ... M	-	-	-	ESC10YE1 ... P	solder fixing receptacle
8533-2YE ... P	EN2997-YE0 ... M	-	-	-	ESC10YE2 ... P	square flange hermetic receptacle
8533-7YE ... P	EN2997-YE7 ... M	-	-	jam nut hermetic receptacle	-	

(1) : Part numbers in specification NLF 54143. Replace EN 2997 by 3.

(2) : Superseded by BACC 63 CN/CM

(3) : 08 for #20 contacts layouts

8533 Series



Contact layouts

viewed from front face of male insulator

▲ class 200°C

■ class 260°C

● hermetic

08	▲ ■ ● 08-03 3#20 	▲ ■ 08-98 3#20 		
10	▲ ■ ● 10-05 5#20 	▲ ■ ● 10-06 6#20 		
12	▲ ■ ● 12-03 3#16 	▲ ■ ● 12-12 12#20 		
14	▲ ■ ● 14-04 4#12 	▲ ■ ● 14-07 7#16 	▲ 14-12 9#20 3#16 	▲ ■ ● 14-15 15#20
16	▲ ■ 16-10 10#16 	▲ ■ ● 16-24 24#20 	▲ SN393 44 Coax 50 Ω 1#16 	
18	▲ ■ 18-14 14#16 	▲ ■ ● 18-31 31#20 	▲ ■ 18-08 8#12 	
20	▲ ■ 20-39 39#20 	▲ ■ 20-41 41#20 	▲ ■ 20-16 16#16 	
22	▲ ■ 22-12 12#12 	▲ ■ 22-19 19#16 	▲ ■ 22-3L 27#20 12#16 	▲ ■ ● 22-55 55#20
24	▲ ■ 24-61 61#20 	▲ ■ 24-30 30#16 		
28	▲ ■ 28-42 42#16 			

Consult us - Special product.

For other contacts layout please consult us.

8533 Series



Polarization

alternative shell key and insert positions (MIL STD 1554)																									
positions		shell 08				shell 10				shell 12				shell 14				shell 16				shell 18			
key	e° insert	a°	b°	c°	d°	a°	b°	c°	d°	a°	b°	c°	d°	a°	b°	c°	d°	a°	b°	c°	d°	a°	b°	c°	d°
N	0	105	140	215	265	105	140	215	265	105	140	215	265	105	140	215	265	105	140	215	265	105	140	215	265
6	0	102	132	248	320	102	132	248	320	18	149	192	259	18	149	192	259	18	149	192	259	18	149	192	259
7	0	80	118	230	312	80	118	230	312	92	152	222	342	92	152	222	342	92	152	222	342	92	152	222	342
8	0	35	140	205	275	35	140	205	275	84	152	204	334	84	152	204	334	84	152	204	334	84	152	204	334
9	0	—	—	—	—	—	—	—	—	24	135	199	240	24	135	199	240	24	135	199	240	—	—	—	—
Y	0	—	—	—	—	—	—	—	—	—	—	—	—	98	152	268	338	98	152	268	338	—	—	—	—

alternative shell key and insert positions (MIL STD 1554)																	
positions		shell 20				shell 22				shell 24				shell 28			
key	e° insert	a°	b°	c°	d°	a°	b°	c°	d°	a°	b°	c°	d°	a°	b°	c°	d°
N	0	105	140	215	265	105	140	215	265	105	140	215	265	105	140	215	265
6	0	18	149	192	259	18	149	192	259	18	149	192	259	18	149	192	259
7	0	92	152	222	342	92	152	222	342	92	152	222	342	92	152	222	342
8	0	84	152	204	334	—	—	—	—	—	—	—	—	—	—	—	—
9	0	24	135	199	240	—	—	—	—	—	—	—	—	—	—	—	—
Y	0	98	152	268	338	—	—	—	—	—	—	—	—	—	—	—	—

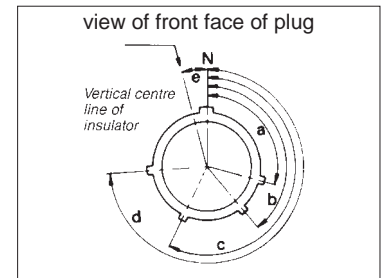

Crimp contacts

contact size	type	part numbers		code by colour bands	admissible wire section		external ø over insulator		
		male contact	female contact		AWG	mm ²	min.	Max.	
class 175°C and 200°C	20	standard large barrel	8526-1348 8522-2349A	8526-1344 8520-292	red - red red - violet	24-20 24-18	0.21-0.60 0.21-0.93	0.85 0.85	2.10 2.10
	16	standard large barrel small barrel	8526-1349 8522-6179A 8526-4175	8526-1346 8522-6180A 8526-4176	blue - blue blue - orange blue - orange	20-16 18-14 22-18	0.60-1.34 0.93-1.91 0.38-0.93	1.20 1.20 1.20	2.70 2.70 2.70
	12	standard large barrel	8526-1350 8526-5041	8526-1347 8526-5591	yellow - yellow yellow - violet	14-12 22-18	1.91-3.18 0.38-0.93	1.90 1.90	4.01 4.01
class 260°C	20	standard large barrel	8533-1000 8533-1002	8533-1001 8533-1003	red - red + 1 white dot red - violet + 1 white dot	24-20 22-18	0.25-0.60 0.38-0.93	0.85 0.85	2.10 2.10
	20	double crimping	8533-1019	8533-1018	red - green + 1 white dot	22	0.4	-	1.25
	16	standard large barrel small barrel	8533-1004 8533-1006 8533-1008	8533-1005 8533-1007 8533-1009	blue - blue + 1 white dot blue - orange + 1 white dot blue - violet + 1 white dot	20-16 18-14 22-18	0.60-1.34 0.93-1.91 0.38-0.93	1.20 1.20 1.20	2.70 2.70 2.70
	12	standard	8533-1035	8533-1036	yellow - yellow + 1 white dot	14-12	1.91-3.18	1.90	4.01

Thermocouple contacts

contact size	type	C : chromel A : alumel	male contact		female contact		admissible wire section		external ø over insulator		
			part numbers	code by colour bands	part numbers	code by colour bands	AWG	mm ²	min.	Max.	
class 175°C and 200°C	standard	C	8522-875A	brown-orange-green	8522-877A	brown-yel.-brown	24-20	0.21-0.60	0.85	2.10	
		A	8522-876A	brown-orange-yel.	8522-878A	brown-yel.-black					
	large barrel	C	8522-3761	yellow 2 dots	8522-3770	yellow 2 dots	22-18	0.38-0.93	0.85	2.10	
		A	8522-3760	black 2 dots	8522-3771	black 2 dots					
	16	standard	C	8522-881	yellow 1 dot	8522-883	yellow 1 dot	20-16	0.60-1.34	1.20	2.70
			A	8522-882	black 1 dot	8522-884	black 1 dot				
12	standard	C	8522-887	yellow 1 dot	8522-889	yellow 1 dot	14-12	1.91-3.18	1.90	4.01	
		A	8522-888	black 1 dot	8522-890	black 1 dot					

8533 Series



Dimensions

Plug type 3 classes WS - RS - KS - ES and type 4 classes WS - AS - KS - ES with backshells

Aluminum backshells

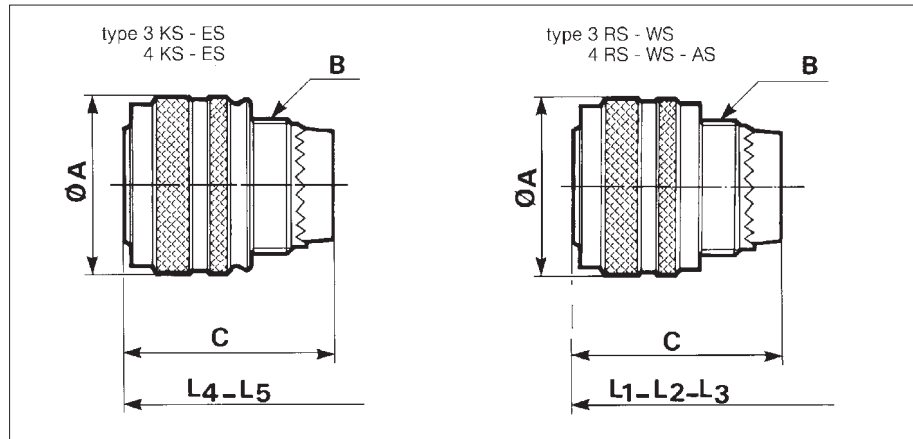
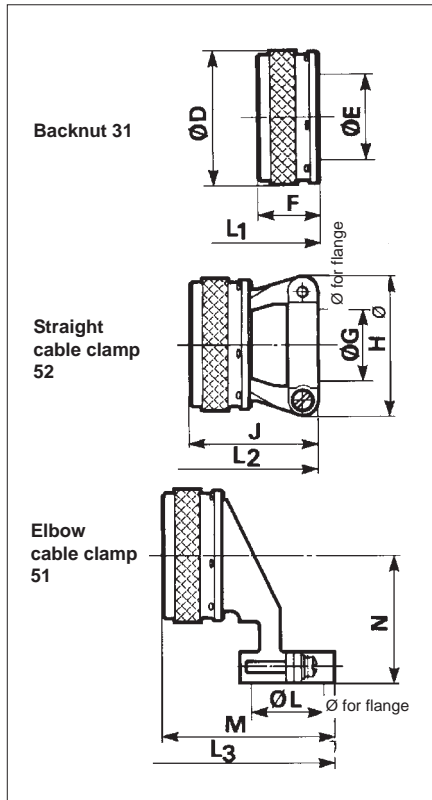

Stainless steel backshells

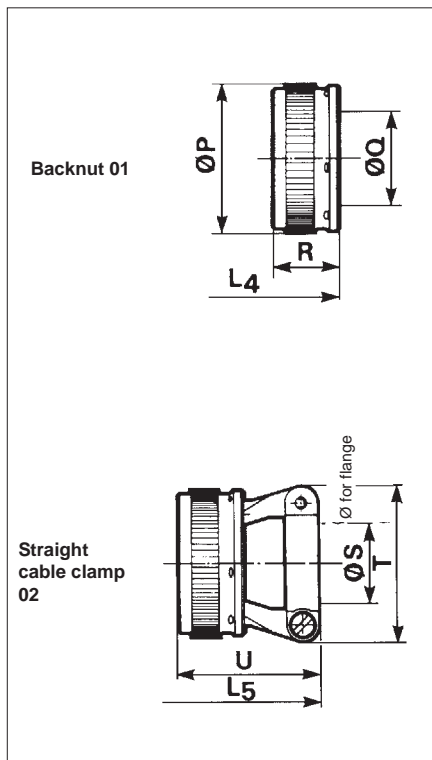

shell size	08	10	12	14	16	18	20	22	24	28
A Max	21.30 .839	24.90 .980	29.60 1.165	31.25 1.230	34.42 1.355	37.34 1.470	41.91 1.650	44.07 1.735	47.24 1.860	52.00 2.047
B Thread	1/2"-20 UNEF 2A	5/8"-24 UNEF 2A	3/4"-20 UNEF 2A	7/8"-20 UNEF 2A	1"-20 UNEF 2A	1-1/16"-18 UNEF 2A	1-3/16"-18 UNEF 2A	1-5/16"-18 UNEF 2A	1-7/16"-18 UNEF 2A	1-3/4"-18 UNEF 2A
C Max	34.50 1.358	34.50 1.358	34.50 1.358	34.50 1.358	34.50 1.358	34.50 1.358	34.50 1.358	34.50 1.358	34.50 1.358	34.50 1.358
D Max	15.65 .616	18.60 .732	21.75 .856	24.95 .982	28.20 1.110	30.90 1.217	34.15 1.344	37.25 1.467	40.45 1.593	-
E	6.75 .266	9.40 .370	12.80 .504	14.75 .581	17.93 .706	19.94 .785	23.11 .910	26.29 1.035	29.20 1.150	-
F Max	12.85 .506	12.85 .506	12.85 .506	12.85 .506	12.85 .506	12.85 .506	12.85 .506	12.85 .506	12.85 .506	-
L1 Max	36.00 1.417	36.00 1.417	36.00 1.417	36.00 1.417	36.00 1.417	36.00 1.417	36.00 1.417	36.00 1.417	36.00 1.417	-
G min	3.20 .126	4.75 .187	7.40 .291	8.90 .350	12.75 .502	13.45 .530	14.75 .581	16.35 .644	17.95 .707	-
G Max	5.20 .205	7.25 .285	10.60 .417	12.10 .476	15.90 .626	17.90 .705	21.10 .831	24.30 .957	27.50 1.083	-
H Max	19.10 .752	21.10 .831	25.10 .988	26.60 1.047	33.50 1.319	36.90 1.453	39.50 1.555	42.00 1.654	45.10 1.776	-
J Max	22.65 .892	24.45 .963	27.85 1.096	27.85 1.096	30.85 1.215	37.85 1.490	40.45 1.593	44.35 1.746	46.75 1.841	-
L2 Max	45.80 1.803	47.60 1.874	51.00 2.008	51.00 2.008	54.00 2.126	61.00 2.402	63.60 2.504	67.50 2.657	69.90 2.752	-
N Max	20.50 .807	22.00 .866	23.60 .929	25.20 .992	26.80 1.055	31.30 1.232	32.90 1.295	34.50 1.358	36.10 1.421	-
L min	3.20 .126	4.75 .187	7.40 .291	8.90 .350	12.75 .502	13.15 .518	14.75 .581	16.35 .644	17.95 .707	-
L Max	5.20 .205	7.25 .285	10.60 .417	12.10 .476	15.90 .626	17.90 .705	21.10 .831	24.30 .957	27.50 1.083	-
M Max	27.60 1.087	29.30 1.154	31.90 1.256	33.40 1.315	37.30 1.469	38.70 1.524	40.25 1.585	41.90 1.650	43.50 1.713	-
L3 Max	50.75 1.998	52.45 2.065	55.05 2.167	56.55 2.226	60.45 2.380	61.85 2.435	63.40 2.496	65.05 2.561	66.65 2.624	-
P Max	15.20 .598	18.30 .720	21.50 .846	24.70 .972	28.70 1.130	29.60 1.165	32.90 1.295	36.00 1.417	39.50 1.555	-
Q Max	7.50 .295	9.70 .382	12.90 .508	14.90 .587	18.05 .711	20.05 .789	23.40 .921	26.40 1.039	29.50 1.161	-
R Max	12.70 .500	12.70 .500	12.70 .500	12.70 .500	12.70 .500	12.70 .500	12.70 .500	12.70 .500	12.70 .500	-
L4 Max	36.00 1.417	36.00 1.417	36.00 1.417	36.00 1.417	36.00 1.417	36.00 1.417	36.00 1.417	36.00 1.417	36.00 1.417	-
S min	3.18 .125	4.75 .187	7.40 .291	8.91 .351	12.72 .501	13.16 .518	14.76 .581	16.36 .644	17.93 .706	-
S Max	5.18 .204	7.26 .286	10.57 .416	12.10 .476	15.88 .623	17.93 .706	21.11 .831	24.28 .956	27.46 1.081	-
T Max	19.10 .752	21.15 .833	25.10 .988	26.60 1.047	33.50 1.319	36.90 1.453	39.60 1.559	42.00 1.654	45.10 1.776	-
U Max	22.50 .886	25.35 .998	28.50 1.122	28.50 1.122	31.70 1.248	38.05 1.498	41.50 1.634	44.40 1.748	47.60 1.874	-
L5 Max	45.80 1.803	48.65 1.915	51.80 2.039	51.80 2.039	55.00 2.165	61.35 2.415	64.80 2.551	67.70 2.665	70.90 2.791	-

8533 Series



Square flange receptacle type 0 classes WS - RS - AS - KS - ES with backshells

Aluminum backshells

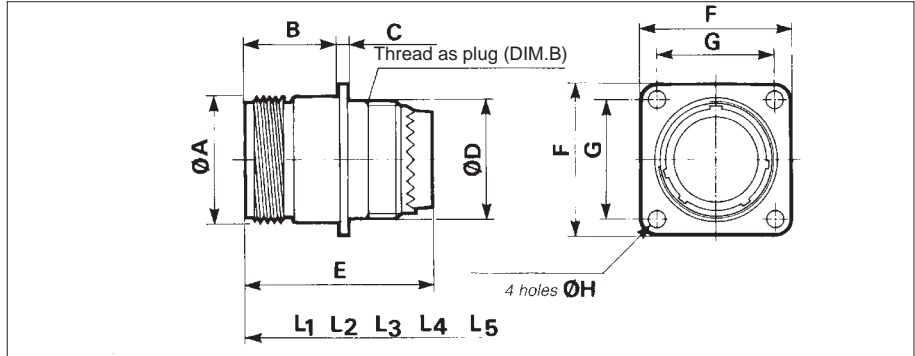
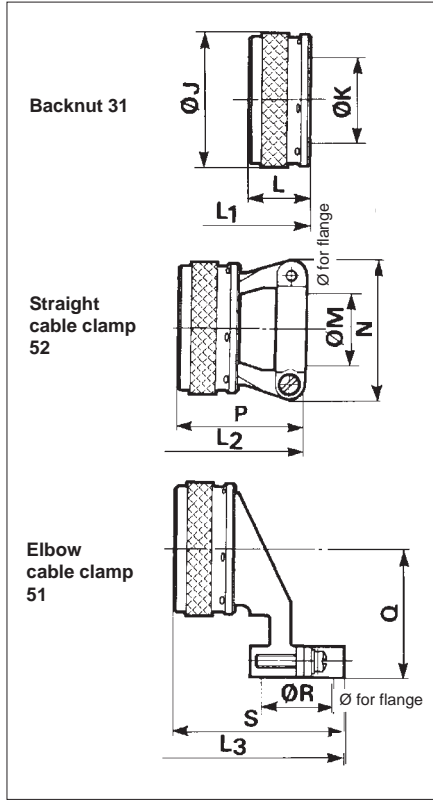

shell size	08	10	12	14	16	18	20	22	24	28
A Max	14.27 .562	17.48 .688	22.22 .875	23.83 .938	26.97 1.062	30.18 1.188	33.32 1.312	36.53 1.438	39.67 1.562	45.99 1.811
B Max	18.35 .722	18.35 .722	18.35 .722	18.35 .722	18.35 .722	18.35 .722	18.35 .722	18.35 .722	18.35 .722	18.35 .722
C Min	1.32 .052	1.32 .052	1.32 .052	1.32 .052	1.32 .052	1.32 .052	1.32 .052	1.32 .052	1.32 .052	1.32 .052
C Max	1.82 .072	1.82 .072	1.82 .072	1.82 .072	1.82 .072	1.82 .072	1.82 .072	1.82 .072	1.82 .072	1.82 .072
D Max	12.66 .498	15.84 .624	19.02 .749	22.19 .874	25.36 .998	26.95 1.061	30.12 1.186	33.30 1.311	36.47 1.436	44.41 1.748
E Max	36.00 1.417	36.00 1.417	36.00 1.417	36.00 1.417	36.00 1.417	36.00 1.417	36.00 1.417	36.00 1.417	36.00 1.417	36.00 1.417
F Max	20.75 .817	23.95 .943	26.31 1.036	28.69 1.130	31.88 1.255	34.24 1.348	36.63 1.442	39.80 1.567	43.38 1.708	50.83 2.001
G	15.09 .594	18.26 .719	20.62 .812	23.01 .906	24.61 .969	26.97 1.062	29.36 1.156	31.75 1.250	34.92 1.375	39.67 1.562
H Max	3.10 .122	3.10 .122	3.10 .122	3.10 .122	3.10 .122	3.10 .122	3.10 .122	3.10 .122	3.90 .154	3.90 .154
J Max	15.65 .616	18.60 .732	21.75 .856	24.95 .982	28.20 1.110	30.90 1.217	34.15 1.344	37.25 1.467	40.45 1.593	-
K	6.75 .266	9.40 .370	12.80 .504	14.75 .581	17.95 .707	19.95 .785	23.10 .909	26.30 1.035	40.45 1.593	-
L Max	12.85 .506	12.85 .506	12.85 .506	12.85 .506	12.85 .506	12.85 .506	12.85 .506	12.85 .506	12.85 .506	-
L1 Max	37.60 1.480	37.60 1.480	37.60 1.480	37.60 1.480	37.60 1.480	37.60 1.480	37.60 1.480	37.60 1.480	37.60 1.480	-
M Min	3.20 .126	4.75 .187	7.40 .291	8.90 .350	12.75 .502	13.15 .518	14.75 .581	16.35 .644	17.95 .707	-
M Max	5.20 .205	7.25 .285	10.60 .417	12.10 .476	15.90 .626	17.90 .705	21.10 .831	24.30 .957	27.50 1.083	-
N Max	19.10 .752	21.10 .831	25.10 .988	26.60 1.047	33.50 1.319	36.90 1.453	39.50 1.555	42.00 1.654	45.10 1.776	-
P Max	22.65 .892	24.45 .963	27.85 1.096	27.85 1.096	30.85 1.215	37.85 1.490	40.45 1.593	44.35 1.746	46.75 1.841	-
L2 Max	47.40 1.866	49.20 1.937	52.60 2.071	52.60 2.071	55.60 2.189	62.60 2.465	65.20 2.567	69.10 2.720	71.50 2.815	-
Q Max	20.50 .807	22.00 .866	23.60 .929	25.20 .992	26.80 1.055	31.30 1.232	32.90 1.295	34.50 1.358	36.10 1.421	-
R Min	3.20 .126	4.75 .187	7.40 .291	8.90 .350	12.75 .502	13.15 .518	14.75 .581	16.35 .644	17.95 .707	-
R Max	5.20 .205	7.25 .285	10.60 .417	12.10 .476	15.90 .626	17.90 .705	21.10 .831	24.30 .957	27.50 1.083	-
S Max	27.60 1.087	29.30 1.154	31.90 1.256	33.40 1.315	37.30 1.469	38.70 1.524	40.25 1.585	41.90 1.650	43.50 1.713	-
L3 Max	52.35 2.061	54.05 2.128	56.65 2.230	58.15 2.289	62.05 2.443	63.45 2.498	65.00 2.559	66.65 2.624	68.25 2.687	-
T Max	15.20 .598	18.30 .720	21.50 .846	24.70 .972	28.10 1.106	29.60 1.165	32.90 1.295	36.00 1.417	39.50 1.555	-
U Max	7.50 .295	9.70 .382	12.90 .508	14.90 .587	18.05 .711	20.05 .789	23.40 .921	26.40 1.039	29.50 1.161	-
V Max	12.70 .500	12.70 .500	12.70 .500	12.70 .500	12.70 .500	12.70 .500	12.70 .500	12.70 .500	12.70 .500	-
L4 Max	37.60 1.480	37.60 1.480	37.60 1.480	37.60 1.480	37.60 1.480	37.60 1.480	37.60 1.480	37.60 1.480	37.60 1.480	-
W Min	3.18 .125	4.75 .187	7.40 .291	8.91 .351	12.72 .501	13.16 .518	14.76 .581	16.36 .644	17.93 .706	-
W Max	5.18 .204	7.26 .286	10.57 .416	12.10 .476	15.88 .625	17.93 .706	21.11 .831	24.28 .956	27.46 1.081	-
X Max	19.10 .752	21.15 .833	25.10 .988	26.60 1.047	33.50 1.319	36.90 1.453	39.60 1.559	42.00 1.654	45.10 1.776	-
Y Max	22.50 .886	25.35 .998	28.50 1.122	28.50 1.122	31.70 1.248	38.05 1.498	41.50 1.634	44.40 1.748	47.60 1.874	-
L5 Max	47.40 1.866	50.25 1.978	53.40 2.102	53.40 2.102	56.60 2.228	62.95 2.478	66.40 2.614	69.30 2.728	72.60 2.858	-

Stainless steel backshells

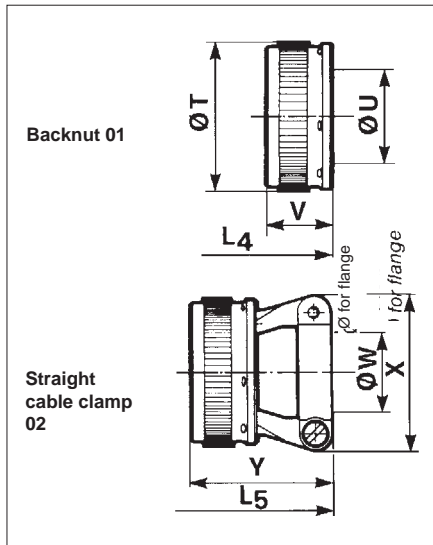

8533 Series



Jam nut receptacle type 7 classes WS - RS - AS - KS - ES with backshells

Aluminum backshells

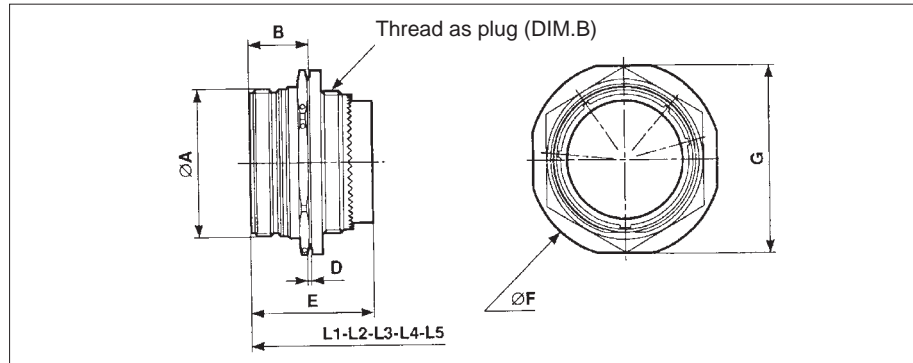
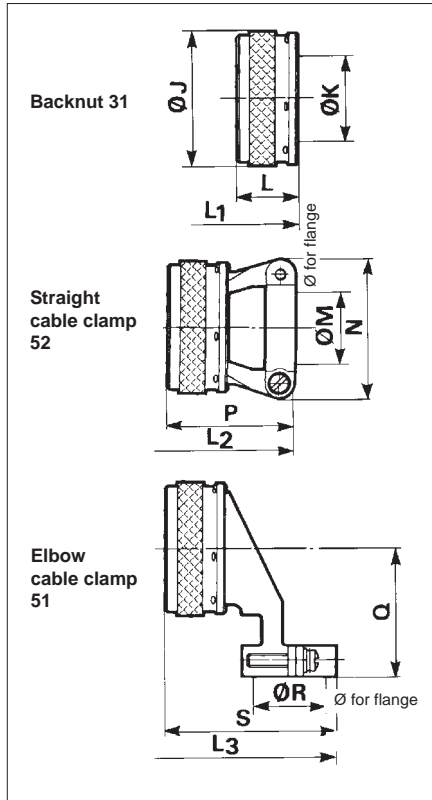

shell size	08	10	12	14	16	18	20	22	24
A Max	14.27 .562	17.47 .688	22.22 .875	23.82 .938	26.97 1.062	30.18 1.188	33.32 1.312	36.53 1.438	39.67 1.562
B Max	19.84 .781	19.84 .781	19.84 .781	19.84 .781	19.84 .781	19.84 .781	19.84 .781	19.84 .781	19.84 .781
D	min 3.18 .125	3.18 .125	3.18 .125	3.18 .125	3.18 .125	3.18 .125	3.18 .125	3.18 .125	3.18 .125
Max	1.57 .062	1.57 .062	1.57 .062	1.57 .062	1.57 .062	1.57 .062	1.57 .062	1.57 .062	1.57 .062
E Max	36.00 1.417	36.00 1.417	36.00 1.417	36.00 1.417	36.00 1.417	36.00 1.417	36.00 1.417	36.00 1.417	36.00 1.417
F Max	27.38 1.078	30.28 1.192	35.05 1.380	38.51 1.516	41.68 1.641	44.86 1.766	49.63 1.954	52.78 2.078	55.42 2.182
G Max	24.89 .980	28.04 1.104	32.79 1.291	35.33 1.391	38.51 1.516	41.68 1.641	44.86 1.766	49.63 1.954	52.81 2.079
H Max	21.06 .829	24.23 .954	29.01 1.142	30.61 1.205	33.76 1.329	36.96 1.455	40.11 1.579	43.31 1.705	46.46 1.829
J Max	15.65 .616	18.60 .732	21.75 .856	24.95 .982	28.20 1.110	30.90 1.217	34.15 1.344	37.25 1.467	40.45 1.593
K	6.75 .266	9.40 .370	12.80 .504	14.75 .581	17.95 .707	19.95 .785	23.10 .909	26.30 1.035	40.45 1.593
L Max	12.85 .506	12.85 .506	12.85 .506	12.85 .506	12.85 .506	12.85 .506	12.85 .506	12.85 .506	12.85 .506
L1 Max	37.60 1.480	37.60 1.480	37.60 1.480	37.60 1.480	37.60 1.480	37.60 1.480	37.60 1.480	37.60 1.480	37.60 1.480
M	min 3.20 .126	4.75 .187	7.40 .291	8.90 .350	12.75 .502	13.15 .518	14.75 .581	16.35 .644	17.95 .707
Max	5.20 .205	7.25 .285	10.60 .417	12.10 .476	15.90 .626	17.90 .705	21.10 .831	24.30 .957	27.50 1.083
N Max	19.10 .752	21.10 .831	25.10 .988	26.60 1.047	33.50 1.319	36.90 1.453	39.50 1.555	42.00 1.654	45.10 1.776
P Max	22.65 .892	24.45 .963	27.85 1.096	27.85 1.096	30.85 1.215	37.85 1.490	40.45 1.593	44.35 1.746	46.75 1.841
L2 Max	47.40 1.866	49.20 1.937	52.60 2.071	52.60 2.071	55.60 2.189	62.60 2.465	65.20 2.567	69.10 2.720	71.50 2.815
O Max	20.50 .807	22.00 .866	23.60 .929	25.20 .992	26.80 1.055	31.30 1.232	32.90 1.295	34.50 1.358	36.10 1.421
R	min 3.20 .126	4.75 .187	7.40 .291	8.90 .350	12.75 .502	13.15 .518	14.75 .581	16.35 .644	17.95 .707
Max	5.20 .205	7.25 .285	10.60 .417	12.10 .476	15.90 .626	17.90 .705	21.10 .831	24.30 .957	27.50 1.083
S Max	27.60 1.087	29.30 1.154	31.90 1.256	33.40 1.315	37.30 1.469	38.70 1.524	40.25 1.585	41.90 1.650	43.50 1.713
L3 Max	52.35 2.061	54.05 2.128	56.65 2.230	58.15 2.289	62.05 2.443	63.45 2.498	65.00 2.559	66.65 2.624	68.25 2.687
T Max	15.20 .598	18.30 .720	21.50 .846	24.70 .972	28.10 1.106	29.60 1.165	32.90 1.295	36.00 1.417	39.50 1.555
U Max	7.50 .295	9.70 .382	12.90 .508	14.90 .587	18.05 .711	20.05 .789	23.40 .921	26.40 1.039	29.50 1.161
V Max	12.70 .500	12.70 .500	12.70 .500	12.70 .500	12.70 .500	12.70 .500	12.70 .500	12.70 .500	12.70 .500
L4 Max	37.60 1.480	37.60 1.480	37.60 1.480	37.60 1.480	37.60 1.480	37.60 1.480	37.60 1.480	37.60 1.480	37.60 1.480
W	min 3.18 .125	4.75 .187	7.40 .291	8.91 .351	12.72 .501	13.16 .354	14.76 .581	16.36 .644	17.93 .706
Max	5.18 .204	7.26 .286	10.57 .416	12.10 .476	15.88 .625	17.93 .706	21.11 .831	24.28 .956	27.46 1.081
X Max	19.10 .752	21.15 .833	25.10 .988	26.60 1.047	33.50 1.319	36.90 1.453	39.60 1.559	42.00 1.654	45.10 1.776
Y Max	22.50 .886	25.35 .998	28.50 1.122	28.50 1.122	31.70 1.248	38.05 1.498	41.50 1.634	44.40 1.748	47.60 1.874
L5 Max	47.40 1.866	50.25 1.978	53.40 2.102	53.40 2.102	56.60 2.228	62.95 2.478	66.40 2.614	69.30 2.728	72.60 2.858

Stainless steel backshells

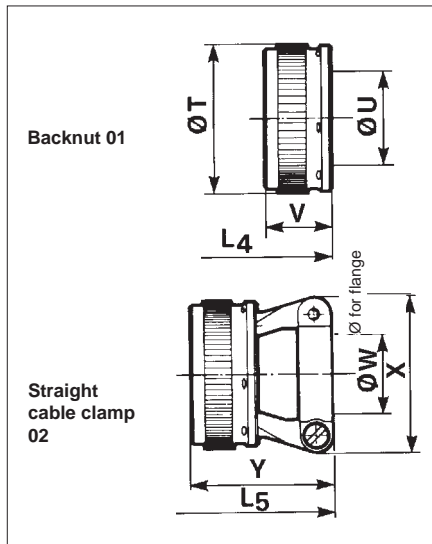

8533 Series



Panel cut-out

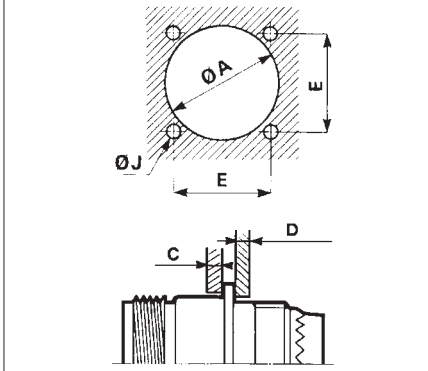

Type 0

shell size	08	10	12	14	16	18	20	22	24	28
A min	15.80 .622	18.70 .736	23.40 .921	24.90 .980	28.30 1.114	31.10 1.224	34.50 1.358	37.50 1.476	40.60 1.598	48.00 1.890
E	15.09 .594	18.26 .719	20.62 .812	23.01 .906	24.61 .969	26.97 1.062	29.36 1.156	31.75 1.250	34.92 1.375	39.67 1.562
J	3.20 .126	3.20 .126	3.20 .126	3.20 .126	3.20 .126	3.20 .126	3.20 .126	3.20 .126	3.80 .150	3.80 .150
C Max	3.18 .125	3.18 .125	3.18 .125	3.18 .125	3.18 .125	3.18 .125	3.18 .125	3.18 .125	3.18 .125	3.18 .125
D Max	3.18 .125	3.18 .125	3.18 .125	3.18 .125	3.18 .125	3.18 .125	3.18 .125	3.18 .125	3.18 .125	3.18 .125

Panel cut-out

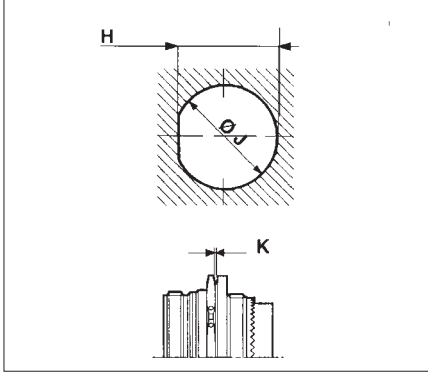

Type 7

shell size	08	10	12	14	16	18	20	22	24
J	16.00 .630	19.17 .755	23.92 .942	25.52 1.005	28.70 1.130	31.87 1.255	35.05 1.380	38.22 1.505	41.40 1.630
H	15.24 .600	18.41 .725	23.16 .912	24.76 .975	27.94 1.100	30.99 1.220	34.16 1.345	37.33 1.470	40.51 1.595
K Max	3.18 .125	3.18 .125	3.18 .125	3.18 .125	3.18 .125	3.18 .125	3.18 .125	3.18 .125	3.18 .125

Dimensions

Hermetic receptacle Type 1Y/1YE

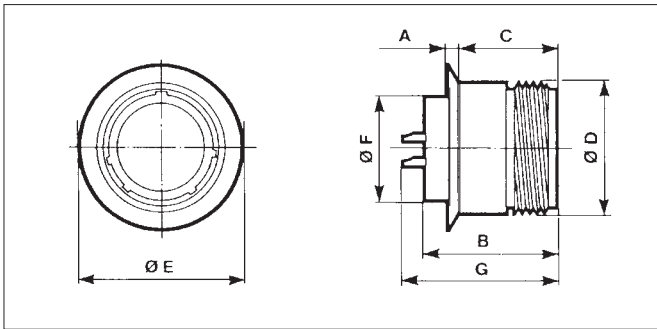

Panel cut-out

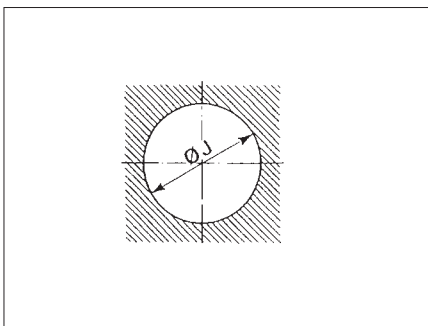

shell size	A Max	B Max	C Max	D Max	E Max	F Max	G Max	ØJ min
08	1.45 .057	22.05 .868	18.45 .726	14.29 .563	18.12 .713	12.70 .500	26.50 1.043	12.96 .510
10	1.45 .057	22.05 .868	18.45 .726	17.46 .687	21.52 .847	14.25 .561	26.50 1.043	14.53 .572
12	1.45 .057	22.05 .868	18.45 .726	22.22 .875	26.57 1.046	19.05 .750	26.50 1.043	19.30 .760
14	1.45 .057	22.05 .868	18.45 .726	23.81 .937	27.82 1.095	20.60 .811	26.50 1.043	20.88 .822
16	1.45 .057	22.05 .868	18.45 .726	26.99 1.063	30.92 1.217	23.79 .937	26.50 1.043	24.05 .947
18	1.45 .057	22.05 .868	18.45 .726	30.16 1.187	34.22 1.347	26.95 1.061	26.50 1.043	27.23 1.072
20*	1.45 .057	22.05 .868	18.45 .726	33.34 1.313	37.22 1.465	30.12 1.186	26.50 1.043	30.40 1.097
22	1.45 .057	22.05 .868	18.45 .726	36.51 1.437	40.62 1.599	33.30 1.311	26.50 1.043	23.58 .928
24*	1.45 .057	22.05 .868	18.45 .726	39.69 1.563	43.62 1.717	36.47 1.436	26.50 1.043	36.70 1.445

* Consult us

8533 Series



Hermetic receptacle type 2Y/2YE

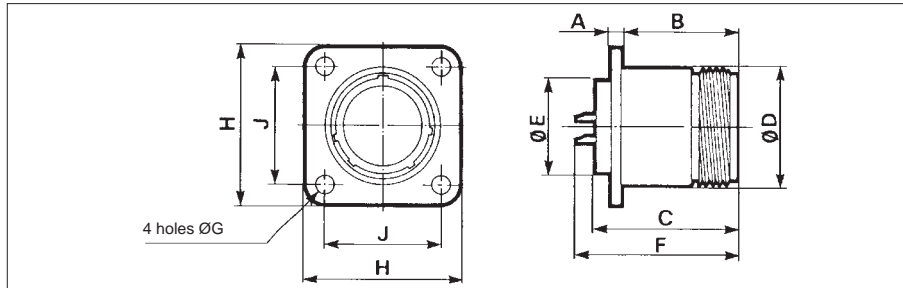

shell size	A Max	B Max	C Max	D Max	E Max	F Max	G Max	H Max	J Max
08	1.45 .057	18.35 .722	22.05 .868	14.29 .563	12.70 .500	26.50 1.043	3.00 .118	20.75 .817	15.09 .594
10	1.45 .057	18.35 .722	22.05 .868	17.46 .687	14.25 .561	26.50 1.043	3.00 .118	23.95 .943	18.26 .719
12	1.45 .057	18.35 .722	22.05 .868	22.22 .875	19.05 .750	26.50 1.043	3.00 .118	26.31 1.036	20.62 .812
14	1.45 .057	18.35 .722	22.05 .868	23.81 .937	20.60 .811	26.50 1.043	3.00 .118	28.69 1.130	23.01 .906
16	1.45 .057	18.35 .722	22.05 .868	26.99 1.063	23.79 .937	26.50 1.043	3.00 .118	31.88 1.255	24.61 .969
18	1.45 .057	18.35 .722	22.05 .868	30.16 1.187	26.95 1.061	26.50 1.043	3.00 .118	34.24 1.348	26.97 1.062
20*	1.45 .057	18.35 .722	22.05 .868	33.34 1.313	30.12 1.186	26.50 1.043	3.00 .118	36.63 1.442	29.36 1.156
22	1.45 .057	18.35 .722	22.05 .868	36.51 1.437	33.30 1.311	26.50 1.043	3.00 .118	39.80 1.567	31.75 1.250
24*	1.45 .057	18.35 .722	22.05 .868	39.69 1.563	36.47 1.436	26.50 1.043	3.80 .150	43.38 1.708	34.92 1.375

* Not industrialized

Hermetic receptacle type 7Y/7YE

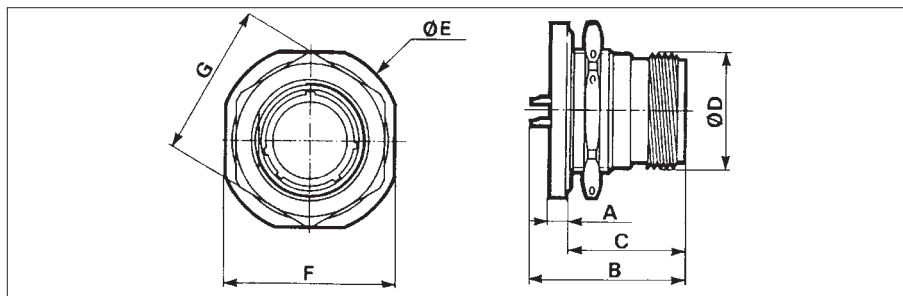

shell size	A Max	B Max	C Max	D Max	E Max	F Max	G Max
08	2.60 .102	26.50 1.043	19.52 .769	14.29 .563	27.35 1.077	24.85 .978	20.12 .792
10	2.60 .102	26.50 1.043	19.52 .769	17.46 .687	30.24 1.191	28.00 1.102	24.20 .953
12	2.60 .102	26.50 1.043	19.52 .769	22.22 .875	35.01 1.378	32.75 1.289	28.95 1.140
14	2.60 .102	26.50 1.043	19.52 .769	23.81 .937	38.46 1.514	35.29 1.389	30.30 1.193
16	2.60 .102	26.50 1.043	19.52 .769	26.99 1.063	41.64 1.639	38.46 1.514	33.45 1.317
18	2.60 .102	26.50 1.043	19.52 .769	30.16 1.187	44.81 1.764	41.64 1.639	34.64 1.364
20*	3.35 .132	26.50 1.043	19.52 .769	33.34 1.313	49.60 1.953	44.86 1.766	39.80 1.567
22	3.35 .132	26.50 1.043	19.52 .769	36.51 1.437	52.74 2.076	49.59 1.952	43.00 1.693
24*	3.35 .132	26.50 1.043	19.52 .769	39.69 1.563	55.40 2.181	52.81 2.079	46.15 1.817

* Not industrialized

Panel cut-out

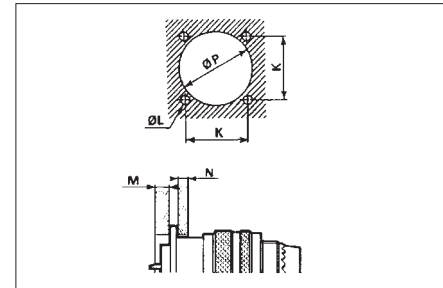

K	L	M	N Max	P min
15.09 .594	3.20 .126	3.18 .125	3.18 .125	15.70 .618
18.26 .719	3.20 .126	3.18 .125	3.18 .125	18.90 .744
20.62 .812	3.20 .126	3.18 .125	3.18 .125	23.50 .925
23.01 .906	3.20 .126	3.18 .125	3.18 .125	25.10 .988
24.61 .969	3.20 .126	3.18 .125	3.18 .125	28.30 1.114
26.97 1.062	3.20 .126	3.18 .125	3.18 .125	31.40 1.236
29.36 1.156	3.20 .126	3.18 .125	3.18 .125	34.60 1.362
31.75 1.250	3.20 .126	3.18 .125	3.18 .125	37.80 1.488
34.92 1.375	4.00 .157	3.18 .125	3.18 .125	40.90 1.610

Panel cut-out

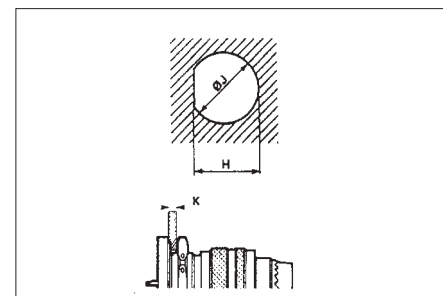

H	J	K Max
15.24 .600	16.00 .630	3.17 .125
18.41 .725	19.17 .755	3.17 .125
23.16 .912	23.92 .942	3.17 .125
24.76 .975	25.52 1.005	3.17 .125
27.94 1.100	28.70 1.130	3.17 .125
30.99 1.220	31.87 1.255	3.17 .125
34.16 1.345	35.05 1.380	3.17 .125
37.33 1.470	38.22 1.505	3.17 .125
40.51 1.595	41.40 1.630	3.17 .125

8533 Series



Protective caps

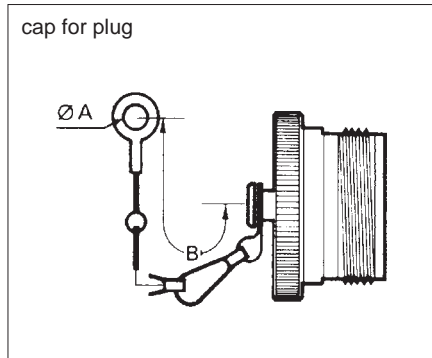

Aluminum version

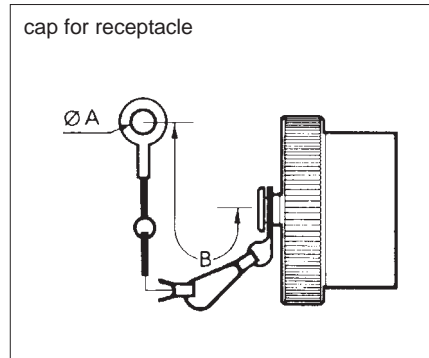

shells	A Max	B Max
08	3.20 .126	134.00 5.276
10	3.20 .126	134.00 5.276
12	3.20 .126	134.00 5.276
14	3.20 .126	134.00 5.276
16	3.20 .126	134.00 5.276
18	3.20 .126	134.00 5.276
22	3.20 .126	134.00 5.276

Protective caps Stainless steel version

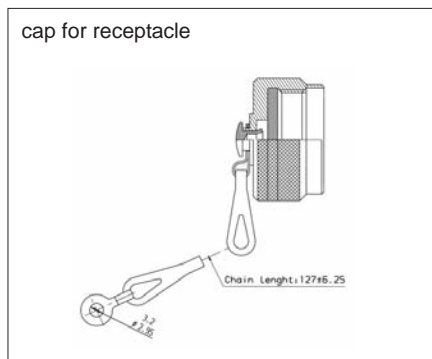

Tooling crimping

contact sizes	wires		part numbers	
	mm ²	AWG	crimping pliers	locator
20	0.93	18	8365 (M 22520 / 1-01) or 8476-01 (M 22520 / 2-01)	8365-02 (M22520 / 1-02) or 8476-02 (M22520 / 2-02)
	0.60	20		
	0.38	22		
	0.21	24		
16	1.91	14	8365 (M 22520 / 1-01)	8365-02 (M 22520 / 1-02)
	1.34	16		
	0.93	18		
	0.60	20		
12	3.18	12	8365 (M 22520 / 1-01)	8365-02 (M 22520 / 1-02)
	1.91	14		

Insertion and extraction of wired contacts

disposable plastic tool :

- colored tip for insertion
- white tip for extraction

contact sizes	part numbers	colour
20	(M 81969-14-11) 8522-20	red
16	(M 81969-14-03) 8522-16	blue
12	(M 81969-14-04) 8522-12	yellow

Extraction of unwired contacts

contact sizes	part numbers
20	8522-56
16	8522-57
12	8522-58

Filler plug

these filler plugs are installed at the rear of unwired contacts to maintain connector sealing

contact sizes	part numbers	colour
20	8522-389 A*/MS 27488-20	red
16	8522-390 A*/MS 27488-16	blue
12	8522-391 A*/MS 27488-12	yellow

* for class 200°C only

Reusable fixing plate

Two, three or four holes self locking fixing plates, see page 759.



Technical Features And Benefits

A unique contact design with a braid socket

- Enabling **20 contact points** for a size 4 contact vs 2 or 3 for a standard socket,
- Allowing **20 % more intensity** as compared to standard socket,
- Excellent **vibration withstanding**,
- Insure **excellent crimping** (crimping bucket can be heat treated to insure good plasticity without affecting the active part elasticity insured by the braid – added after heat treatment).

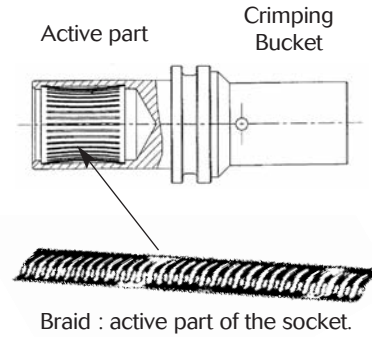

20 contact points on the pin for a #4 contact

Cut of a contact mated pair

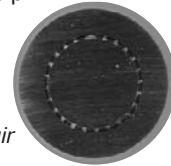

A versatile individual sealing on the cable

- Sealing on the cable done thanks to a sealing boot,
- Same connector can accommodate a **wild range of cable diameter**.



Longitudinal cut of a connector

A contact technology integrated in well proven standard aeromil connectors

- Up to 260°C service temperature,
- Up to 43G vibration withstanding.





8533 - ABS Power Series



Description

- Range extension of the EN2997-ESC 10 standards for **High Power Supply**
 - Screw coupling.
 - Removable crimp contacts for up to **80 Amps** (#4).
 - High vibrations resistant.
 - **High temperature resistant** (up to 260°C for some layouts).
- **ABS compliant** (ABS 1340-1343, 1426-1427)
- **Versatile individual sealing** on the cable:
 - Sealing through a sealing boot.
 - Various range of cable diameter accomodated by the same connector.
- **Fluid resistant** providing **maximum protection** against fuel, oils, etc.
- **Hermetic and quadrax** version available.
- **Titanium version** available for light and robust solutions.

Applications

- Electro mechanical actuator power supply, alternator, starter applications.

Technical Features

Mechanical

- **Shell:** Aluminum alloy (class R-W), Stainless steel (class E-K), Titanium (Class TT or TF).
- **Plating:** Nickel, black anodized, olive green cadmium, passivated, without plating.
- **Grommet and seal:** silicon elastomer.
- **Insulator:** Thermoplastic.
- **Contact body:** Copper Alloy.
- **Contact plating:** Gold Over Nickel.
- **Contact retention:**
 - # 4 : 200N, # 6 : 156 N
- **Endurance:** 500 mating / unmating operation.
- **Vibration & shock:** according to EN 2997.

Electrical

- **Dielectric withstanding:**

Altitude	Service
Alt ground	1500 Vrms
15 000 m	600 Vrms
21 000 m	400 Vrms
33 000 m	200 Vrms

- **Insulation Resistance:** 5000 MΩ under 500 Vdc.
- **Max current rating per contact:**
 - # 4 : 80 A.
 - # 6 : 60 A.
- **Contact resistance:** 1 mΩ
- **Electrical continuity:** 5mΩ with RFI shielding.
- **Shielding:** to 100 MHz at 1 GHz Attenuation \geq 65dB.

Environmental

- **Temperature range:**
 - 60°C+175°C class W,
 - 60°C +200°C class R, A and K and TF,
 - 60°C +260°C class E and TT.
- **Leakage:** low pressure immersion. L 54001 and interfacial sealing: pressure 2 kpa.
- **Damp Heat:** as per EN2997 10 cycles of 24 hours.
- **Salt Spray:** 48 hours (class A-R-K-E), 500 hours (class W).
- **Fire resistance:** as per EN 2997 (Class E, K).

Resistance to fluid

MIL-H 5606 – SKYDROL 500 B4-LD4
 JP5-MIL-L7870A – MIL L 23699
 MIL –L 7808 –MIL C 25769 –
 MIL- A 8243.



3D view

Male Plug with backshell

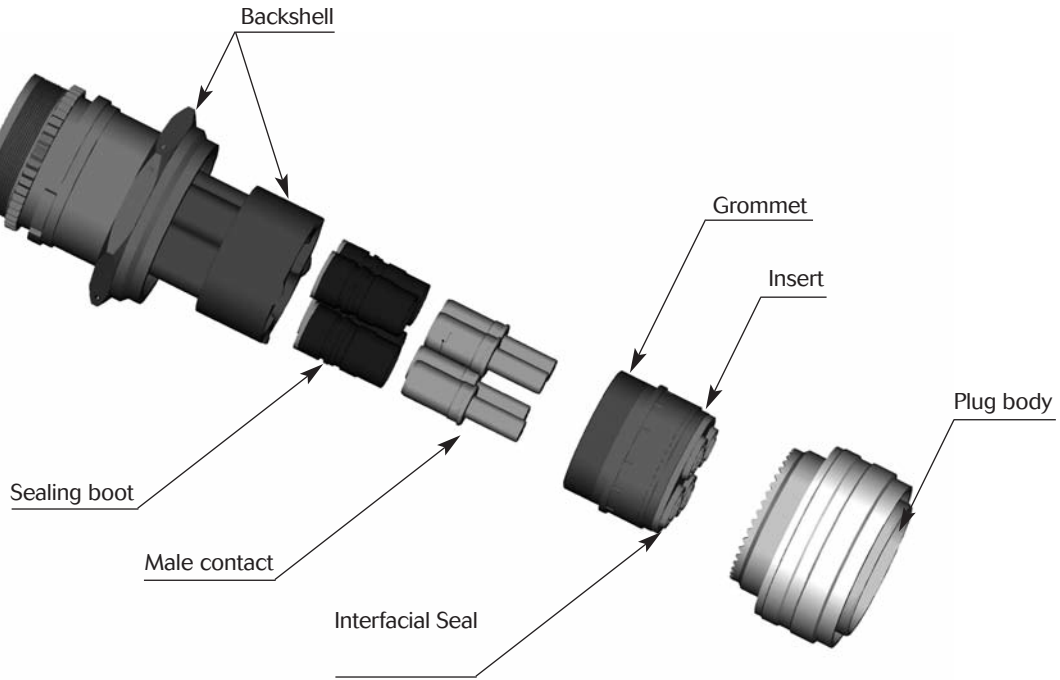

Female receptacle with backshell

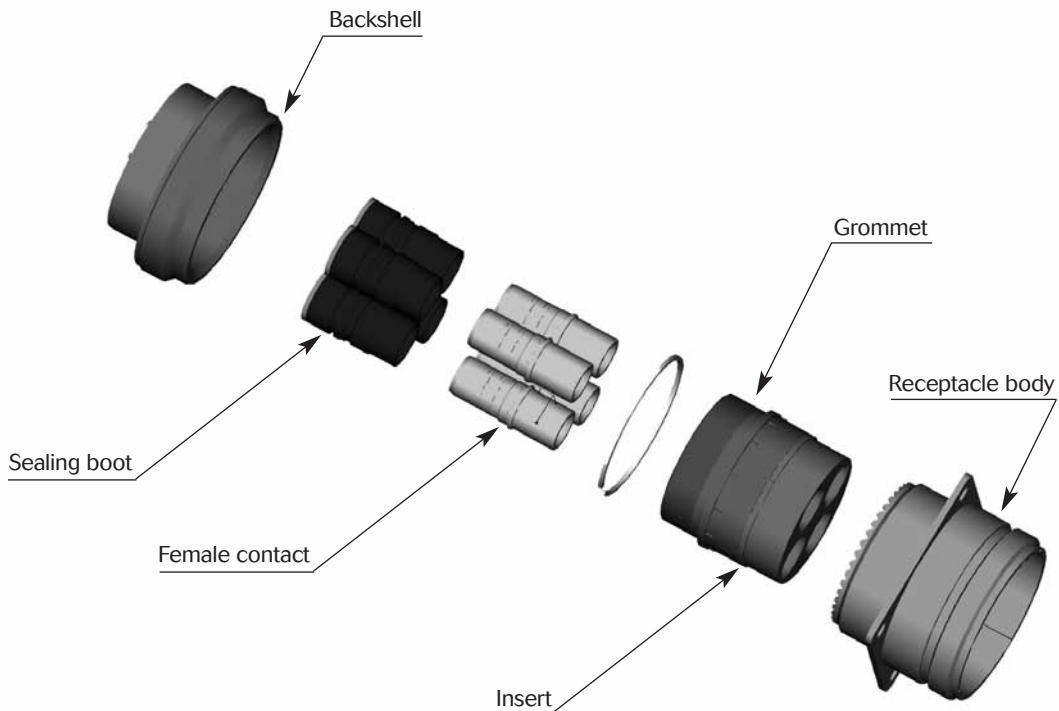

8533 - ABS Power Series



Layouts

18-02	20-04	24-04	24-03	28-06
<p>2 contacts size 8 Quadrax version only</p>	<p>4 contacts size 6*</p>	<p>4 contacts size 4</p>	<p>3 contacts size 6* Power version only</p>	<p>6 contacts size 6*</p>

* Quadrax version available.

ABS Cross Reference

		Circular plug		Receptacle square Flange												
		SOURIAU Reference	ABS Reference	SOURIAU Reference	ABS Reference											
Aluminium Version	8533 3RS2004PNL	8533 3RS2004PN126	8533 3RS2004SNL	8533 3RS2004SN126	ABS 1343 C-2004 NF	ABS 1343 P-2004 NF	ABS 1343 D-2004 NF	ABS 1343 S-2004 NF	8533 ORS2004PNL	8533 ORS2004PN126	8533 ORS2004SNL	8533 ORS2004SN126	ABS 1426 C-2004 NF	ABS 1426 P-2004 NF	ABS 1426 D-2004 NF	ABS 1426 S-2004 NF
	8533 3RS2404PNL	8533 3RS2404PN126	8533 3RS2404SNL	8533 3RS2404SN126	ABS 1343 C-2404 NF	ABS 1343 P-2404 NF	ABS 1343 D-2404 NF	ABS 1343 S-2404 NF	8533 ORS2404PNL	8533 ORS2404PN126	8533 ORS2404SNL	8533 ORS2404SN126	ABS 1426 C-2404 NF	ABS 1426 P-2404 NF	ABS 1426 D-2404 NF	ABS 1426 S-2404 NF
	8533 3RS2806PNL	8533 3RS2806PN126	8533 3RS2806SNL	8533 3RS2806SN126	ABS 1343 C-2806 NF	ABS 1343 P-2806 NF	ABS 1343 D-2806 NF	ABS 1343 S-2806 NF	8533 ORS2806PNL	8533 ORS2806PN126	8533 ORS2806SNL	8533 ORS2806SN126	ABS 1426 C-2806 NF	ABS 1426 P-2806 NF	ABS 1426 D-2806 NF	ABS 1426 S-2806 NF
	8533 3ES2004PNL	8533 3ES2004PN126	8533 3ES2004SNL	8533 3ES2004SN126	ABS 1340 C-2004 NF	ABS 1340 P-2004 NF	ABS 1340 D-2004 NF	ABS 1340 S-2004 NF	8533 OES2004PNL	8533 OES2004PN126	8533 OES2004SNL	8533 OES2004SN126	ABS 1427 C-2004 NF	ABS 1427 P-2004 NF	ABS 1427 D-2004 NF	ABS 1427 S-2004 NF
	8533 3ES2806PNL	8533 3ES2806PN126	8533 ERS2806SNL	8533 3ES2806SN126	ABS 1340 C-2806 NF	ABS 1340 P-2806 NF	ABS 1340 D-2806 NF	ABS 1340 S-2806 NF	8533 OES2806PNL	8533 OES2806PN126	8533 OES2806SNL	8533 OES2806SN126	ABS 1427 C-2806 NF	ABS 1427 P-2806 NF	ABS 1427 D-2806 NF	ABS 1427 S-2806 NF



Dimensions Plug Type 3 ABS 1340 - 1343

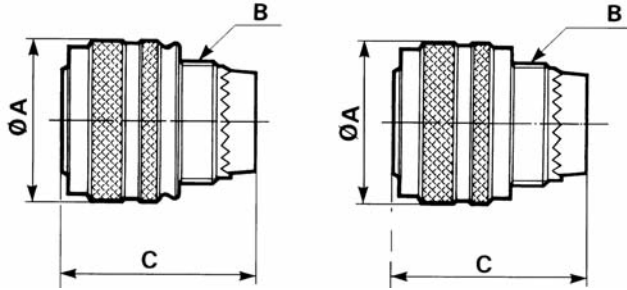

Shell size	20	24	28
A max	41,91	47,24	52,00
B (thread)	1-3/16 18 UNEF 2A	1-7/16 18 UNEF 2A	1-3/4 18 UNEF 2A
C max	34,50	34,50	34,50

Dimensions Receptacle Type 0 ABS 1426 - 1427

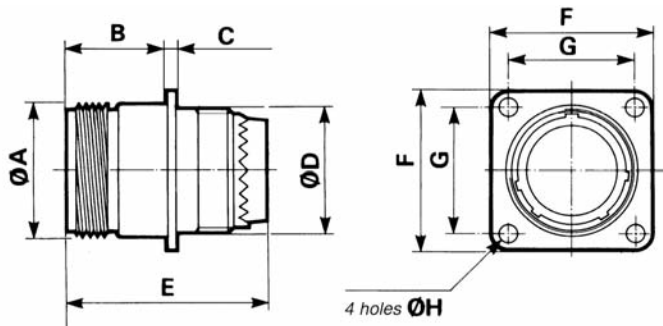

Shell size	20	24	28
A max	33,32	39,67	45,99
B max	18,35	18,35	18,35
C max	1,45	1,45	1,45
D max	30,12	36,47	44,41
E max	36,00	36,00	36,00
F max	36,63	43,88	50,83
G	29,36	34,92	39,67
H max	3,10	3,90	3,90

Dimensions Receptacle Type 7

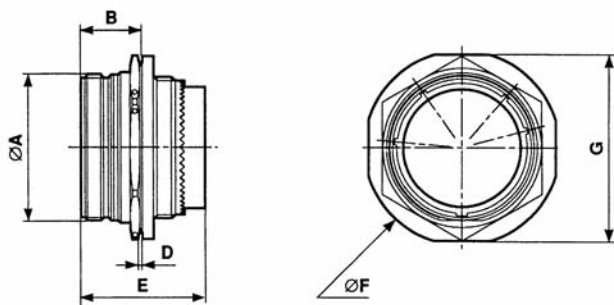

Shell size	20	24
A max	33,32	39,67
B max	19,84	19,84
D min	3,18	3,18
D max	1,57	1,57
E max	36,00	36,00
F max	49,63	55,42
G max	44,86	52,81



8533 Series

Hermetic Jam Nut Receptacle shell size 20



Technical Features

Mechanical

- Shell: Stainless steel.
- Plating: Passivated.
- Interfacial seal: silicon elastomer.
- Insulator: Glass.
- Contact body: Gold Plated steel.

Electrical

- Max current rating: 46 A.

Environmental

- Temperature range: -65 °C + 200 °C.
- Leakage rate: 1.10-9.
- Salt Spray: 48 h.

P/N 8533 7Y 20-04 PN 112

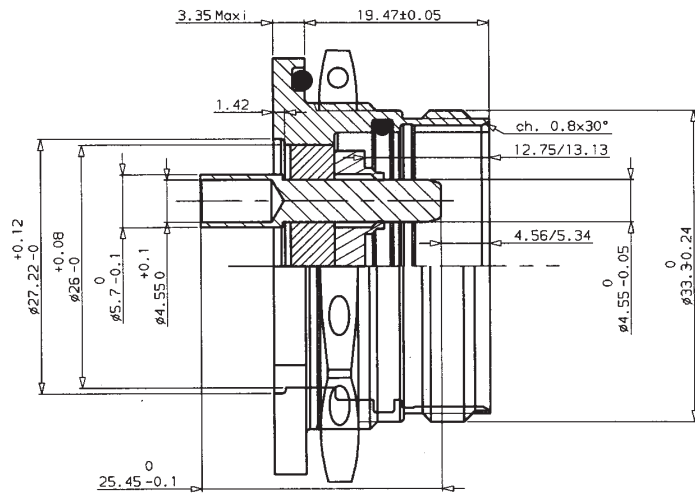
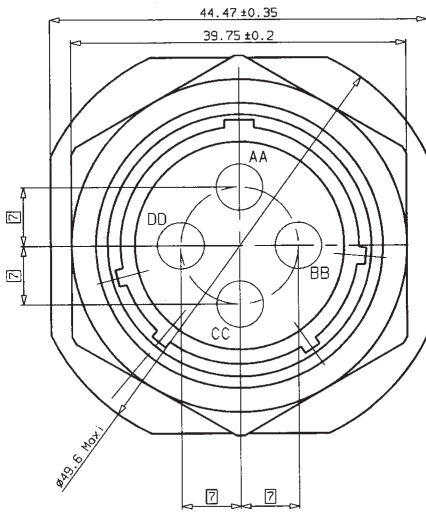



Strain relief Backshell ABS 1452

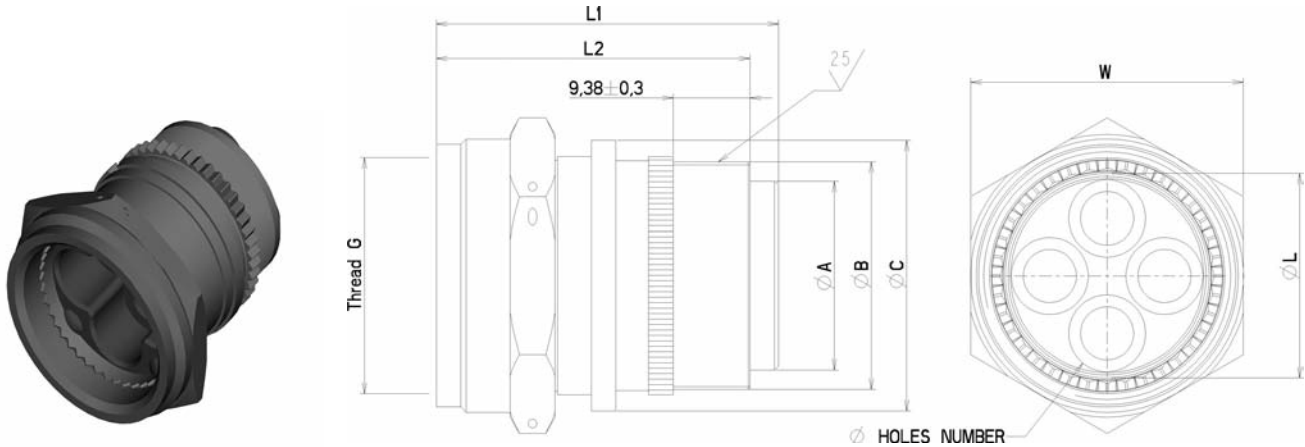

Layout code	Souriau Ref.	ABS Ref.	ØA ± 0.05	ØB ± 0.1	ØC Max	ØL ± 0.05	ØL1 ± 1.20	ØL2 ± 1	W ± 0.12	Number of holes	Thread Class 2B	Mass (g)
20-04 Alu	8533 8250	ABS 1452 A 2004	22.94	27.72	30.12	24.1	41.78	38.28	33.21	4	1.1875-18 UNEF	73
20-04 Stainless Steel	8533- 8281	ABS 1452 C 2004										
24-04 Alu	8533 8223	ABS 1452 A 2404	29.8	33.71	38	31.2	48.8	46.28	45	4	1.7/16/18 UNEF	95
24-04 Stainless Steel	Consult us	ABS 1452 C 2404										
28-06 Alu	8533 8245	ABS 1452 A 2806	34.74	39.7	44.4	37.7	41.78	38.28	47.49	6	1.7500- 18UNS	116
28-06 Stainless Steel	8533- 8288	ABS 1452 C 2806										



8533 Series

Contacts

Socket contact ABS 1344

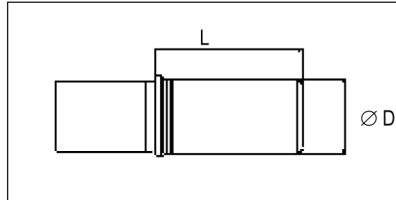

Socket contact ABS 1403

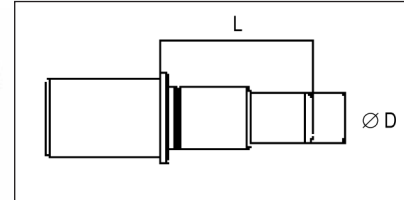
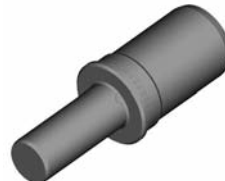

Contact size	Contact type	Souriau reference	ABS reference	Cable			Dimensions	
				Conductor size (mm ²)	AWG	Material	L Max (mm)	D Max (mm)
4	MALE	8533-8202	ABS 1403 104KZ06	9 & 14	8 & 6	Copper	14,55	5,74
4	MALE	8533-8201	ABS 1403 104KZ04	22	4	Copper	14,55	5,74
4	FEMALE	8533-8171	ABS 1344 104LZ06	9 & 14	8 & 6	Copper	11,15	9,6
4	FEMALE	8533-8120	ABS 1344 104LZ04	22	4	Copper	11,15	9,6
6	MALE	8533-8246	ABS 1403 1K6LZ06	14	6	Copper	13,7	4,59
6	MALE	8533-8272	ABS 1403 1K6LZ08	9	8	Copper	13,7	4,59
6	MALE	8533-8248	ABS 1403 1K6LZ10	5 & 3	10 & 12	Copper	13,7	4,59
6	FEMALE	8533-8247	ABS 1344 1K6LZ06	14	6	Copper	15,3	7,33
6	FEMALE	8533-8273	ABS 1344 1K6LZ08	9	8	Copper	15,3	7,33
6	FEMALE	8533-8249	ABS 1344 1K6LZ10	5 & 3	10 & 12	Copper	15,3	7,33

Sealing boot ABS 0992

Contact size	Cable AWG	Cable material	SOURIAU part Number Class 200 °C	ABS part Number Class 200 °C	SOURIAU part Number Class 260 °C	ABS part Number Class 260 °C	A	B
#6	6	Copper	8533-8296	ABS0992-A 03	8533-8308	Consult us	3.30 to 4.83	13 max
#6	8	Copper	8533-8236	ABS0992-A 05	8533-8307	Consult us	3.30 to 4.83	13 max
#6	10 to 12	Copper	8533-8287	ABS0992-A 02	8533-8306	Consult us	3.30 to 4.83	13 max
#6	quad ABS0973 / 0974	Copper	8533-8236	ABS0992-A 01			3.30 to 4.83	13 max
#4	4	Copper	8599-4591	ABS0992C04	Consult us	Consult us	3.30 to 4.83	23±0.005
#4	6	Copper	8533-8163	ABS0992C05	Consult us	Consult us	3.30 to 4.83	23±0.005
#4	8	Copper	8533-8163	ABS0992C05	Consult us	Consult us	3.30 to 4.83	23±0.005
#4	10 to 12	Copper	8533-8262		Consult us	Consult us	3.30 to 4.83	23±0.005
Filler plug								
#4	4	Blue PTFE	8533-8253	ASNE0616BC0400 ASNE0616BB0400	Consult us	Consult us	3.30 to 4.83	23±0.005

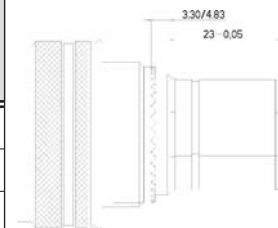



Tooling

Contact size	Contact type	Contact reference	Cable			Crimping tool		Die-set	Sealing boot Locator	extraction tool
			Conductor size (mm ²)	AWG	Cable material	Pneumatic				
4	MALE	8533-8202	9 & 14	8 & 6	Copper	M22520/23-01	M22520/23-02		8533-8193	
4	MALE	8533-8201	22	4	Copper	M22520/23-01	M22520/23-04	8533-8141	8533-8193	
4	FEMALE	8533-8171	9 & 14	8 & 6	Copper	M22520/23-01	M22520/23-02		8533-8193	
4	FEMALE	8533-8120	22	4	Copper	M22520/23-01	M22520/23-04	8533-8141	8533-8193	
6	MALE	8533-8246	14	6	Copper	M22520/23-01	M22520/23-03		8530-1603	
6	MALE	8533-8272	9	8	Copper	M22520/23-01	M22520/23-02		8530-1603	
6	MALE	8533-8248	5 & 3	10 & 12	Copper	M22520/23-01	WA23-112DA		8530-1603	
6	FEMALE	8533-8247	14	6	Copper	M22520/23-01	M22520/23-03		8530-1603	
6	FEMALE	8533-8273	9	8	Copper	M22520/23-01	M22520/23-02		8530-1603	
6	FEMALE	8533-8249	5 & 3	10 & 12	Copper	M22520/23-01	WA23-112DA		8530-1603	

Pneumatic tool



Die Set (M 22520/23-02)



Crimping tool (M 22520/23-01)

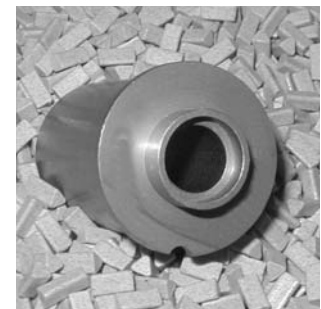

Locator (M 22520/23-11)

Extraction tool

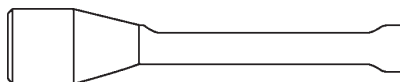
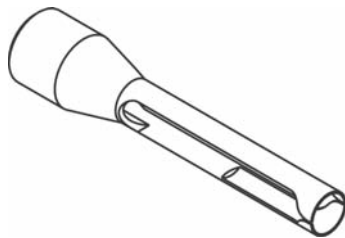

Metallic extraction tool

Contact Size	Material	Part number
06	Plastic	M 811969/14-06 (red)
	Metallic	860-197
04	Plastic	M 811969/14-07 (blue)
	Metallic	8533-8175



Plastic extraction tool



891/2 Series

Applications

Aircraft engines
High temperature applications

Standards

MIL-C 5015 G, class K
NFL 54140



Description

- Screw coupling
- High temperature connector for severe environment
- Fire resistant and fire wall
- High level of shock and vibration
- Thermocouple contacts available except hermetic class
- Stainless steel shells
- Hermetic version available with male contacts only

Characteristics

Mechanical

All 89 series connectors listed below are interchangeable and intermateable with other connectors conforming to MIL-C-5015G, class K.

connector series	temperature range	fire-proof	with self-locking	number of operations	thread plating	interfacial sealing
standard 891	-55° +200°C	yes	yes	500	on plug	yes
standard 892	-55° +260°C	yes	yes	500	on plug	yes
892-04 (ESC.004)	-55° +260°C	yes	yes	500	on plug	no
special 891*	-55° +200°C	yes	no	3000	plug and receptacle	yes
special 892*	-55° +260°C	yes	no	3000	plug and receptacle	yes

* Only available on special request

Firewall and fireproof tests

891, 892 and 892.04 (ESC.004) series, comply with the following specifications :
NF 54140, AIR 8467, test 14
MIL-C 5015G class K - 4.3.20 - 4.6.16
ESC 00015 and ESC 00024

Electrical

Maximum current rating per contact :

contact size	temperature (Max.)		
	20°C	175°C	260°C
16	20	10	7.5
12	35	19	13
4	110	55	39

Dielectric withstanding voltage :

service	at ground level	at 21,000 meters (approx. 69,000 feet)
inst	1000 Vrms	260 Vrms
A	2000 Vrms	360 Vrms
D	2800 Vrms	400 Vrms
E	3500 Vrms	440 Vrms

Insulation resistance (at 500 Vdc) :
at normal temperature 5000 MΩ

Ordering information : 891/2 connectors without backfittings 891/2 hermetic connectors

basic series	89 1 - 00 K -16S- 8 - S - N - L
sub series	1 - 200°C 2 - 260°C
shell style	— - standard connector 00 - square flange receptacle with thread for backfittings 02 - square flange receptacle without thread for backfittings 07 - jam nut receptacle (on request) 06 - plug without self-locking 26 - plug with self-locking — - hermetic connectors 01 - solder fixing receptacle 02 - square flange receptacle 05 - large flange, solder fixing receptacle
class	K - fire resistant (standard) H - hermetic
shell size	- 10SL, 12S, 14S, 16S, 16, 18, 20, 22, 24 or 28
contact layouts	- see table p 274
contacts	P - male S - female
polarization	N (normal), W, X, Y, Z - see table p 275 L - connector without contacts

891/2 Series



891/2 connectors with backfittings

basic series	89	1 - 26	F	- 22 - 14 - P - N - L
sub series	1 - 200°C	2 - 260°C		
shell style	00 - square flange receptacle 07 - jam nut receptacle (on request) 26 - plug with self-locking 06 - plug without self-locking			
type of backfitting	A - straight adapter (8590AXX type) C - elbow adapter (on request) (ESC 87 type) E - simple backnut (may be fitted onto A or C)*(8950 EXX type) F - cable clamp (may be fitted onto A or C)*(ESC 86 XX)			
shell size	- 10SL, 12S, 14S, 16S, 16, 18, 20, 22, 24 or 28			
contact layouts	- see table p 274			
contacts	P - male S - female			
polarization	N (normal), W, X, Y, Z - see table p 275			
L	connectors without contacts			

892 suffix 04 connectors with backfittings (including types corresponding to ESC & PAN nos.)

basic series	89	2 - 26 - E - 24 - 28 - P - N - 04	L
sub series	2 - 260°C		
shell style	00 - square flange receptacle 26 - self-locking plug		
type of backfitting	K - no backfitting A - with straight adapter (8590AXX type) C - with elbow adapter (on request) (ESC 87 type) E - with simple backnut (8950 EXX type) F - with cable clamp (ESC 86 XX)		
shell size	- 10SL, 12S, 14S, 16S, 16, 18, 20, 22, 24 or 28		
contact layouts	- see table p 274 (note : some arrangements are not included in Rolls-Royce JDS 1371 spec.)		
contacts	P - male S - female		
polarization	N (normal), W, X, Y, Z - see table p 275		
	04 - compulsory digits - ESC.004 specification		
	- connectors supplied without contacts (compulsory)		

As above but Rolls-Royce ESC part nos.

Rolls-Royce connector specifications	ESC. 004 - K - O - 24 - 28 - P - N
specification number	
shell style	A - square flange receptacle K - self-locking plug
type of backfitting	O - no backfitting
shell size	- 10SL, 12S, 14S, 16S, 16, 18, 20, 22, 24 or 28
contact layouts	- see table p 274 (note : some arrangements are not included in Rolls-Royce JDS 1371 spec.)
contacts	P - male S - female
polarization	N (normal), W, X, Y, Z - see table p 275

Note : contacts are not supplied with these connectors

891/2 Series



Part number cross reference tables

Souriau 891 (200°C) series/MIL-C 5015G classes KS & HS MIL-C 83723 Series II

Plugs/receptacles with contacts

description	Souriau part number	MIL-C 5015G class KS
square flange receptacle	891.00K..... P	MS3450 KS..... P
	891.00K..... S	MS3450 KS..... S
plug without self locking	891.06K..... P	MS3456 KS..... P
	891.06K..... S	MS3456 KS..... S
plug with self locking	891.26K..... P	MS3459 KS..... P
	891.26K..... S	MS3459 KS..... S
jam nut receptacle	891.07K..... P	
	891.07K..... S	
square flange receptacle	891.02K..... P	
	891.02K..... S	

Contacts

description	Souriau part number
pin. 16.16	8950.4100B
pin. 12.12	8950.4107B
pin. 4.4	8950.4112B
socket 16S.16 short	8950.4101C
socket 16.16 long	8950.4105C
socket 12.12	8950.4108B
socket 4.4	8950.4113B

Hermetic receptacles

description	Souriau part number	MIL-C 5015G class HS
solder mounting	891.01H..... P	
square flange receptacle	891.02H..... P	MS 3142 HS...C ...P
solder mounting	891.05H..... P	MS 3143 HS...C ...P

Souriau 892 (260°C) series / MIL-C 5015G classes KS & HS

Plugs/receptacles with contacts

description	Souriau part number	MIL-C 5015G class KS
square flange receptacle	892.00 K P	MS 3450 KS P
	892.00 K S	MS 3450 KS S
plug without self locking	892.06 K P	MS 3456 KS P
	892.06 K S	MS 3456 KS S
plug with self locking	892.26 K P	MS 3459 KS P
	892.26 K S	MS 3459 KS S
jam nut receptacle	892.07 K P	
	892.07 K S	
square flange receptacle	892.02 K P	
	892.02 K S	

Hermetic receptacles

description	Souriau part number	MIL-C-5015G class HS
solder mounting	892.01 H..... P	
square flange receptacle	892.02 H..... P	MS 3142 HS ...C ...P
solder mounting	892.05 H..... P	MS 3143 HS ...C ...P

Accessories

description	Souriau part number	MIL-C-5015G
size 16 sealing plugs	8522.390A	MS 3187.16.2
size 12 sealing plugs	8522.391A	MS 3187.12.2
size 4 sealing plugs	8950.4152	MS 3187.4.2
size 16 insertion/extraction tool	8522.16	MS 3447.16
size 12 insertion/extraction tool	8522.12	MS 3447.12
size 4 extraction tool	8950.4004	MS 3165.4

891/2 Series



Souriau 891 (200°C) series / NFL 54140 class 1 (France) 892 (260°C) series / NFL 54140 class 2 (France)

Plugs/receptacles with contacts

description	Souriau part number	NFL 54140
square flange receptacle	891 00 2	91 00 2
	892 00 2	92 00 2
plug without self locking	891 06 2	91 06 2
	892 06 2	92 06 2
jam nut receptacle	891 07 2	91 07 2
	892 07 2	92 07 2

Backfittings

description	Souriau part number	NFL 54140
back nut	8950 E	9R
straight adapter	8950 A	9RA
cable clamp	8950 F	9RC

Souriau 892 suffix 04(260°C) series / ESC.004 (Rolls-Royce) PAN 6434 (Panavia)

Plugs/receptacles without contacts

description	Souriau part number	PAN 6434	ESC.004
square flange receptacle	892.00K 04L		ESC.004 AO
plug with self locking	892.26K 04L		ESC.004 KO
hermetic receptacle/solder flange	892.05H 04*		ESC.004 CO

*on request

Receptacles/plugs with end fittings, without contacts

description	Souriau part number	PAN 6434	ESC.004
square flange receptacle with backnut	892.00E 04L	PAN 6434 CG	ESC.004 AA
square flange receptacle with cable clamp	892.00F 04L	PAN 6434 CA	ESC.004 AB
square flange receptacle with straight adapter	892.00A 04L	PAN 6434 CB	ESC.004 AD
plug with straight adapter	892.26A 04L	PAN 6434 DB	ESC.004 KD
plug with cable clamp	892.26F 04L	PAN 6434 DA	ESC.004 KB
plug with elbow adapter	892.26C 04L*	PAN 6434 DE	ESC.004 KE

*on request

Backfittings

description	Souriau part number	PAN 6434	ESC.004
back nut	8950.E		ESC.004 OA
cable clamp	8950.F		ESC.004 OB
straight adapter	8950.A		ESC.004 OD
elbow adapter	8950.C*		ESC.004 OE

*on request













Contacts

description	Souriau part number	PAN 6434	ESC.004
pin, standard, 16.16	8950-5049A 900	PAN 6434 PA	ESC.007 PB 16
pin, standard, 16.24	8950-5048A 900	PAN 6434 PB	ESC.007 PA 16
pin, alumel, 16.16	8950-5149		ESC.007 PB 16A
pin, chromel, 16.16	8950-5143		ESC.007 PB 16C
socket, standard, short 16.16	8950-5052A 900	PAN 6434 SD	ESC.007 SB 16S
socket, standard, short 16.24	8950-5050A 900	PAN 6434 SE	ESC.007 SA 16S
socket, standard, long 16.16	8950-5053A 900	PAN 6434 SF	ESC.007 SB 16L
socket, standard, long 16.24	8950-5051A 900	PAN 6434 SG	ESC.007 SA 16L
socket, alumel, short, 16.16	8950-5151		ESC.007 SB 16SA
socket, alumel, long, 16.16	8950-5153		ESC.007 SB 16LA
socket, chromel, short 16.16	8950-5145		ESC.007 SB 16SC
socket, chromel, long 16.16	8950-5147 900		ESC.007 SB 16LC

891/2 Series



Contact layouts

10SL		12S		14S		16S		16		18	
	3#16		2#16		4#16		7#16		2#12		10#16
10SL.3		12S.3		14S.2		16S.1		16.11		18.1	
	2#16				5#16		5#16				1#16 2#12
10SL.4*				14S.5		16S.8*				18.5*	
					6#16						5#12
				14S.6						18.11	
					3#16						
				14S.7							

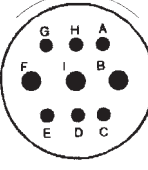
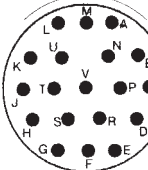
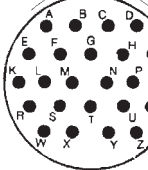
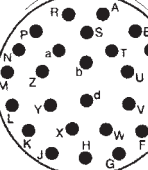
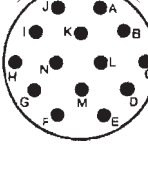
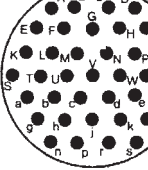
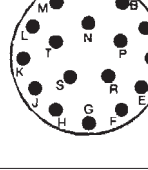
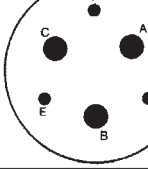
20		22		24		28	
	6#16 3#12		19#16		24#16		26#16
20.18*		22.14		24.28		28.12*	
	14#16						37#16
20.27						28.21	
	17#16						3#16 3#4
20.29						28.22	

* these arrangements not available with ESC.004 (FCI Souriau 892 suffix 04) part numbers

these arrangements are available in hermetic receptacles



Polarization

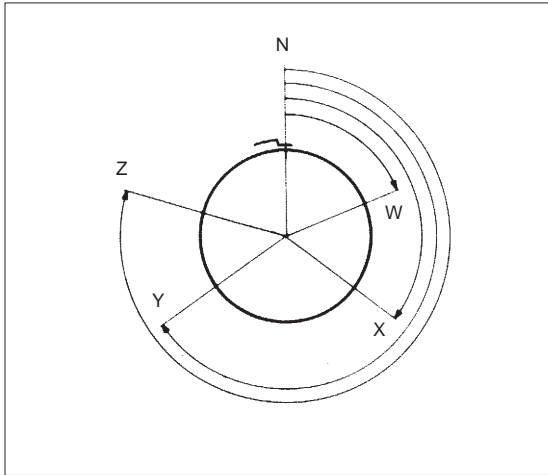

shell size	contact arrangement	orientation in degrees				
		N	W	X	Y	Z
10SL	10SL.3	0	-	-	-	-
	10SL.4	0	-	-	-	-
12S	12S.3	0	70	145	215	290
	14S.2	0	-	120	240	-
14S	14S.5	0	-	110	-	-
	14S.6	0	-	-	-	-
	14S.7	0	90	180	270	-
	16S.1	0	80	-	-	280
16S	16S.8	0	-	170	265	-
	16.11	0	35	110	250	325
18	18.1	0	70	145	215	290
	18.11	0	-	170	265	-
20	20.18	0	35	110	250	325
	20.27	0	35	110	250	325
	20.29	0	80	-	-	280
22	22.14	0	80	-	-	280
24	24.28	0	80	110	250	280
	28.12	0	90	180	270	-
28	28.21	0	80	110	250	280
	28.22	0	70	145	215	290

Standard and thermocouple contacts (with colour bands)

Standard contacts

contact type	size	wire size	891 (200°C) series		892 (260°C) series		892.04 (ESC) series	
			part n°	col. bands	part n°	col. bands	part n°	col. bands
pin	16	16-20	8950-4773A	blue/blue	8950-4773A	blue/blue	8950-5049A	blue/blue
short socket	16	16-20	8950-4778	blue/blue	8950-4778	blue/blue	8950-5052A	blue/blue
long socket	16	16-20	8950-4779	blue/blue	8950-4779	blue/blue	8950-5053A	blue/blue
pin	12	12-14	8950-4774	-	8950-4774	-	-	-
socket	12	12-14	8950-4781	-	8950-4781	-	-	-
pin	4	4-6	8950-4775	-	8950-4775	-	-	-
socket	4	4-6	8950-4783	-	8950-4783	-	-	-

Contacts with reduced barrels

contact type	size	wire size	891 (200°C) series		892 (260°C) series		892.04 (ESC) series	
			part n°	col. bands	part n°	col. bands	part n°	col. bands
pin	16	20-24	8950-5833	-	8950-5833	-	8950-5048A	blue/green
short socket	16	20-24	8950-5835	-	8950-5835	-	8950-5050A	blue/green
long socket	16	20-24	8950-5838	-	8950-5838	-	8950-5051A	blue/green

Special contacts (long barrel with external cable dia. ≥ 3.3 mm)

contact type	size	wire size	891 (200°C) series		892 (260°C) series		892.04 (ESC) series	
			part n°	col. bands	part n°	col. bands	part n°	col. bands
pin	16	16-20	8950-5049A	blue/blue	8950-5049A	blue/blue	-	-
short socket	16	16-20	8950-5052A	blue/blue	8950-5052A	blue/blue	-	-
long socket	16	16-20	8950-5053A	blue/blue	8950-5053A	blue/blue	-	-

Thermocouple alumel contacts

contact type	size	wire size	891 (200°C) series		892 (260°C) series		892.04 (ESC) series	
			part n°	col. dot	part n°	col. dot	part n°	col. bands
pin	16	16-20	8950-4122	black	8950-4122	black	8950-5149	-
short socket	16	16-20	8950-4123B	black	8950-4123B	black	8950-5151	-
long socket	16	16-20	8950-4128B	black	8950-4128B	black	8950-5153	-
pin	16	20-24	8950-5843	black	8950-5843	black	-	-
short socket	16	20-24	8950-5849	black	8950-5849	black	-	-
long socket	16	20-24	8950-5851	black	8950-5851	black	-	-

Thermocouple chromel contacts

contact type	size	wire size	891 (200°C) series		892 (260°C) series		892.04 (ESC) series	
			part n°	col. dot	part n°	col. dot	part n°	col. bands
pin	16	16-20	8950-4132	yellow	8950-4132	yellow	8950-5143	-
short socket	16	16-20	8950-4133B	yellow	8950-4133B	yellow	8950-5145	-
long socket	16	16-20	8950-4138B	yellow	8950-4138B	yellow	8950-5147	-
pin	16	20-24	8950-5841	yellow	8950-5841	yellow	-	-
short socket	16	20-24	8950-5845	yellow	8950-5845	yellow	-	-
long socket	16	20-24	8950-5847	yellow	8950-5847	yellow	-	-

891/2 Series



Dimensions

Plugs - type 06 and type 26

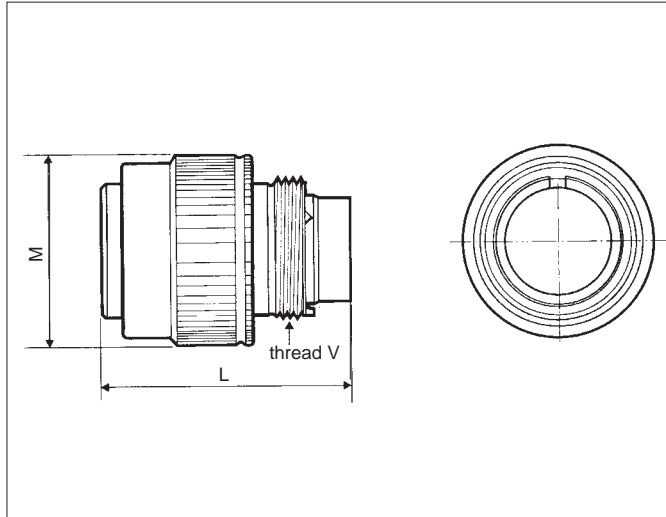

shell size	L	M	V
10SL	39.65 1.56	23.50 0.93	⁵ / ₈ "-24 UNEF.2A
12S	39.65 1.56	25.50 1.00	†
14S	39.65 1.56	28.00 1.10	³ / ₄ "-20 UNEF.2A
16S	39.65 1.56	31.90 1.26	⁷ / ₈ "-20 UNEF.2A
16	44.15 1.74	31.90 1.26	⁷ / ₈ "-20 UNEF.2A
18	44.15 1.74	34.00 1.34	1"-20 UNEF.2A
20	44.15 1.74	37.50 1.48	¹ / ₁₆ "-18 UNEF.2A
22	44.15 1.74	40.60 1.60	¹ / ₄ "-18 UNEF.2A
24	44.15 1.74	43.80 1.72	¹ / ₁₆ "-18 UNEF.2A
28	44.15 1.74	50.00 1.97	¹ / ₈ "-18 UNEF.2A

† : ⁵/₈" - 24 UNEF.2A for all types except Rolls-Royce ESC.004 connectors which have an ¹¹/₁₆" - 24 UNEF.2A thread

Square flange receptacles - type 00

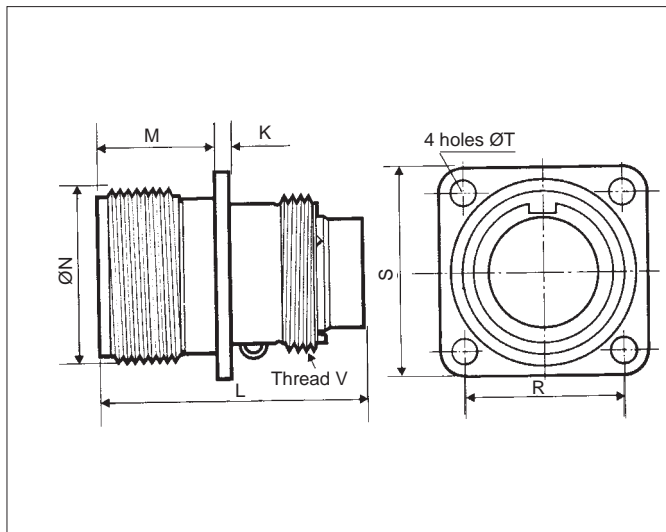

shell size	K	L	M	N	R	S	T	V
10SL	1.60 .06	39.65 1.56	14.90 .59	15.84 .62	18.25 .72	25.25 .99	3.80 .15	⁵ / ₈ "-24 UNEF.2A
12S	1.60 .06	39.65 1.56	14.90 .59	19.02 .75	20.60 .81	27.60 1.09	3.80 .15	†
14S	1.60 .06	39.65 1.56	14.90 .59	22.19 .87	23.00 .91	30.00 1.18	3.80 .15	³ / ₄ "-20 UNEF.2A
16S	1.60 .06	39.65 1.56	14.90 .59	25.40 1.00	24.60 .97	32.62 1.28	3.80 .15	⁷ / ₈ "-20 UNEF.2A
16	1.60 .06	44.15 1.74	19.65 .77	25.40 1.00	24.60 .97	32.62 1.28	3.80 .15	⁷ / ₈ "-20 UNEF.2A
18	1.60 .06	44.15 1.74	19.65 .77	28.50 1.12	26.97 1.06	35.00 1.38	4.60 .18	1"-20 UNEF.2A
20	2.00 .08	44.15 1.74	19.65 .77	31.70 1.25	29.40 1.16	37.40 1.47	4.60 .18	¹ / ₁₆ "-18 UNEF.2A
22	2.00 .08	44.15 1.74	19.65 .77	34.88 1.37	31.75 1.25	40.80 1.61	4.60 .18	¹ / ₄ "-18 UNEF.2A
24	2.00 .08	44.15 1.74	20.65 .81	38.05 1.50	34.90 1.37	43.90 1.73	4.60 .18	¹ / ₁₆ "-18 UNEF.2A
28	2.00 .08	44.15 1.74	20.65 .81	44.40 1.75	39.65 1.56	50.65 1.99	4.60 .18	¹ / ₈ "-18 UNEF.2A

† : ⁵/₈" - 24 NEF.2A for all types except Rolls-Royce ESC.004 connectors which have an ¹¹/₁₆" - 24 NEF.2A thread

Panel cut-out

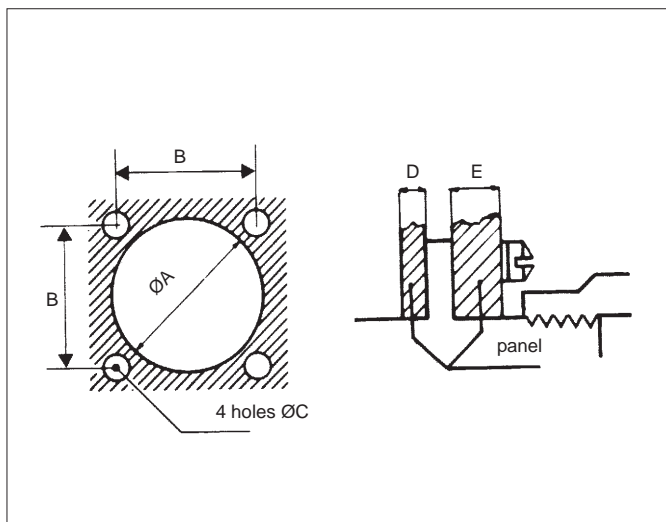

shell size	front of panel				rear of panel			
	A	B	C	D Max	A	B	C	E Max
10SL	20.50 .81	18.25 .72	3.80 .15	10.00 .39	17.00 .67	18.25 .72	3.80 .15	6.0 .24
12S	20.50 .81	20.60 .81	3.80 .15	10.00 .39	20.20 .79	20.60 .81	3.80 .15	6.0 .24
14S	23.50 .93	23.00 .91	3.80 .15	10.00 .39	23.40 .92	23.00 .91	3.80 .15	6.0 .24
16S	26.50 1.04	24.60 .97	3.80 .15	10.00 .39	26.60 1.05	24.60 .97	3.80 .15	6.0 .24
16	26.50 1.04	24.60 .97	3.80 .15	10.00 .39	26.60 1.05	24.60 .97	3.80 .15	5.30 .21
18	29.80 1.17	27.00 1.06	4.60 .18	10.00 .39	29.70 1.17	27.00 1.06	4.60 .18	5.30 .21
20	34.60 1.36	29.40 1.16	4.60 .18	10.00 .39	32.90 1.29	29.40 1.16	4.60 .18	5.30 .21
22	36.20 1.43	31.75 1.25	4.60 .18	10.00 .39	36.10 1.42	31.75 1.25	4.60 .18	5.30 .21
24	41.10 1.62	34.90 1.37	4.60 .18	10.00 .39	39.30 1.55	34.90 1.37	4.60 .18	5.30 .21
28	46.30 1.82	39.65 1.56	4.60 .18	10.00 .39	45.60 1.79	39.65 1.56	4.60 .18	5.30 .21



891/2 Series

Jam nut receptacles - type 07

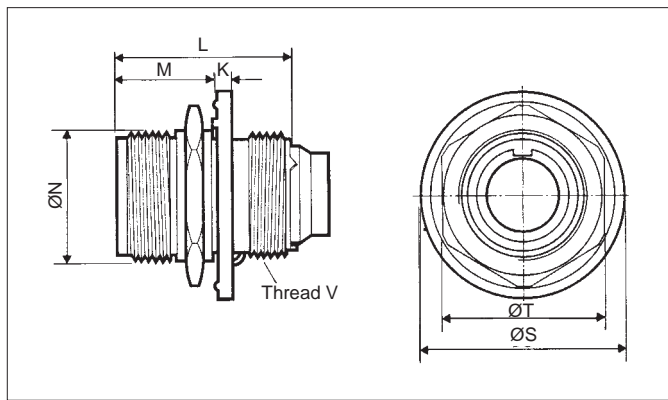

shell size	K	L	M	N	S	T	V
10SL	2.00 .08	32.00 1.26	22.30 .88	15.84 .62	26.00 1.02	20.00 .79	5/8"-24 UNEF.2A
12S	2.00 .08	32.00 1.26	22.30 .88	19.02 .75	29.00 1.14	23.00 .91	†
14S	2.00 .08	32.00 1.26	22.30 .88	22.19 .87	32.50 1.28	26.97 1.06	3/4"-20 UNEF.2A
16S	2.00 .08	32.00 1.26	22.30 .88	25.40 1.00	36.50 1.44	30.17 1.19	7/8"-24 UNEF.2A
16	2.00 .08	36.50 1.44	26.60 1.05	25.40 1.00	36.50 1.44	30.17 1.19	7/8"-20 UNEF.2A
18	2.20 .09	36.50 1.44	26.60 1.05	28.50 1.12	39.00 1.54	33.32 1.31	1"-20 UNEF.2A
20	2.20 .09	36.50 1.44	26.60 1.05	31.70 1.25	44.00 1.73	36.52 1.44	1 1/16"-18 UNEF.2A
22	2.20 .09	36.50 1.44	26.60 1.05	34.88 1.37	47.20 1.86	39.67 1.56	1 1/4"-18 UNEF.2A
24	2.20 .09	36.50 1.44	26.60 1.05	38.05 1.50	50.50 1.99	42.87 1.69	1 7/16"-18 UNEF.2A
28	2.20 .09	36.50 1.44	26.60 1.05	44.40 1.75	57.00 2.24	50.00 1.97	1 5/8"-18 UNEF.2A

Panel cut-out

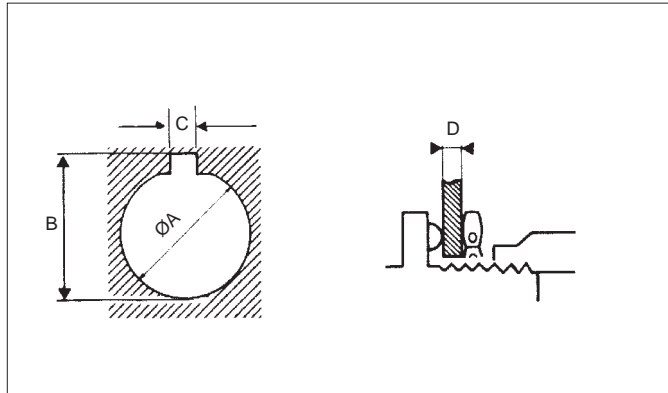

shell size	A	B	C	D Max	D min
10SL	17.00 .67	19.00 .75	1.80 .07	10.50 .41	1.50 .06
12S	20.20 .79	22.20 .87	1.80 .07	10.50 .41	1.50 .06
14S	23.40 .92	25.40 1.00	1.80 .07	10.50 .41	1.50 .06
16S	26.60 1.05	28.60 1.13	1.80 .07	10.50 .41	1.50 .06
16	26.60 1.05	28.60 1.13	1.80 .07	9.30 .37	1.50 .06
18	29.70 1.17	31.70 1.25	1.80 .07	9.30 .37	1.50 .06
20	32.90 1.29	34.90 1.37	1.80 .07	9.30 .37	1.50 .06
22	36.10 1.42	38.10 1.50	1.80 .07	9.30 .37	1.50 .06
24	39.30 1.55	40.30 1.59	1.80 .07	9.30 .37	1.50 .06
28	45.60 1.79	47.60 1.87	1.80 .07	9.30 .37	1.50 .06

† : 5/8" - 24 UNEF.2A for all types except Rolls-Royce ESC.004 connectors which have an 1 1/16" - 24 UNEF.2A thread

Square flange receptacles - type 02

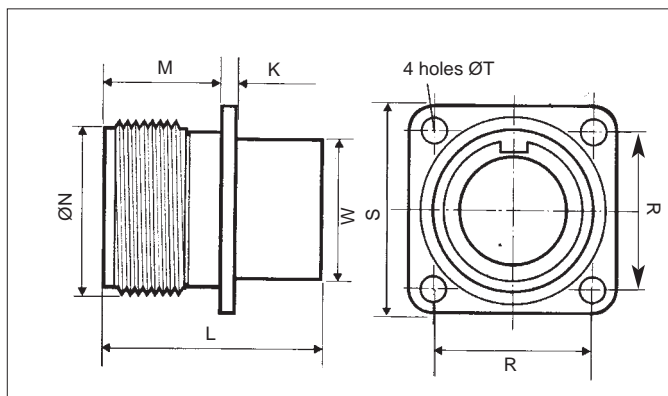

shell size	K	L	M	N	R	S	T	W
10SL	1.60 .06	32.00 1.26	14.90 .59	15.84 .62	18.25 .72	25.25 .99	3.80 .15	14.50 .57
12S	1.60 .06	32.00 1.26	14.90 .59	19.02 .75	20.60 .81	27.60 1.09	3.80 .15	14.50 .57
14S	1.60 .06	32.00 1.26	14.90 .59	22.19 .87	23.00 .91	30.00 1.18	3.80 .15	17.40 .69
16S	1.60 .06	32.00 1.26	14.90 .59	25.40 1.00	24.60 .97	32.62 1.28	3.80 .15	20.65 .81
16	1.60 .06	36.50 1.44	19.65 .77	25.40 1.00	24.60 .97	32.62 1.28	3.80 .15	20.65 .81
18	1.60 .06	36.50 1.44	19.65 .77	28.50 1.12	26.97 1.06	35.00 1.38	4.60 .18	23.70 .93
20	2.00 .08	36.50 1.44	19.65 .77	31.70 1.25	29.40 1.16	37.40 1.47	4.60 .18	28.15 1.11
22	2.00 .08	36.50 1.44	19.65 .77	34.88 1.37	31.75 1.25	40.80 1.61	4.60 .18	29.95 1.18
24	2.00 .08	36.50 1.44	20.65 .81	38.05 1.50	34.90 1.37	43.90 1.73	4.60 .18	33.25 1.31
28	2.00 .08	36.50 1.44	20.65 .81	44.40 1.75	39.65 1.56	50.65 1.99	4.60 .18	39.40 1.55

Panel cut-out

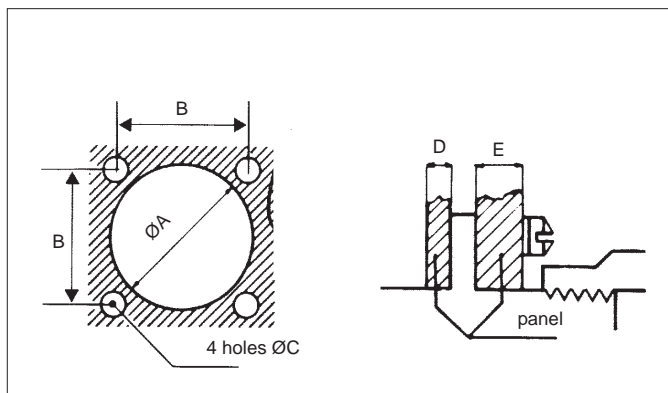

shell size	front of panel				rear of panel			
	A	B	C	D Max	A	B	C	E Max
10SL	20.50 .81	18.25 .72	3.80 .15	10.00 .39	17.00 .67	18.25 .72	3.80 .15	6.0 .24
12S	20.50 .81	20.60 .81	3.80 .15	10.00 .39	20.20 .79	20.60 .81	3.80 .15	6.0 .24
14S	23.50 .93	23.00 .91	3.80 .15	10.00 .39	23.40 .92	23.00 .91	3.80 .15	6.0 .24
16S	26.50 1.04	24.60 .97	3.80 .15	10.00 .39	26.60 1.05	24.60 .97	3.80 .15	6.0 .24
16	26.50 1.04	24.60 .97	3.80 .15	10.00 .39	26.60 1.05	24.60 .97	3.80 .15	5.30 .21
18	29.80 1.17	27.00 1.06	4.60 .18	10.00 .39	29.70 1.17	27.00 1.06	4.60 .18	5.30 .21
20	34.60 1.36	29.40 1.16	4.60 .18	10.00 .39	32.90 1.29	29.40 1.16	4.60 .18	5.30 .21
22	36.20 1.43	31.75 1.25	4.60 .18	10.00 .39	36.10 1.42	31.75 1.25	4.60 .18	5.30 .21
24	41.10 1.62	34.90 1.37	4.60 .18	10.00 .39	39.30 1.55	34.90 1.37	4.60 .18	5.30 .21
28	46.30 1.82	39.65 1.56	4.60 .18	10.00 .39	45.60 1.79	39.65 1.56	4.60 .18	5.30 .21

891/2 Series



Hermetic solder fixing recep. type 01H

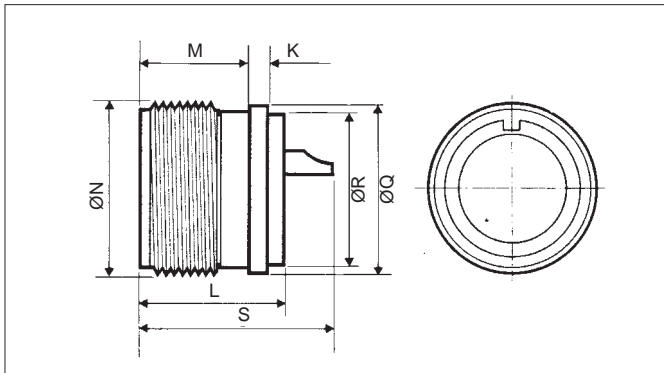

shell size	K	L	M	N	Q	R	S
10SL	1.60 .06	20.40 .80	16.55 .65	15.84 .62	15.84 .62	12.70 .50	29.20 1.15
12S	1.60 .06	20.40 .80	16.55 .65	19.02 .75	19.02 .75	16.70 .66	29.20 1.15
14S	1.60 .06	20.40 .80	16.55 .65	22.19 .87	22.19 .87	18.30 .72	29.20 1.15
16S	1.60 .06	20.40 .80	16.55 .65	25.40 1.00	25.40 1.0	21.40 .84	29.20 1.15
18	2.00 .08	25.15 .99	20.65 .81	28.50 1.12	28.50 1.12	24.70 0.97	33.70 1.32
20	2.00 .08	25.15 .99	21.05 .83	31.70 1.25	32.50 1.25	29.40 1.15	33.70 1.32
28	2.00 .08	25.15 .99	21.05 .83	44.40 1.74	44.40 1.74	41.30 1.62	33.70 1.32

Panel cut-out

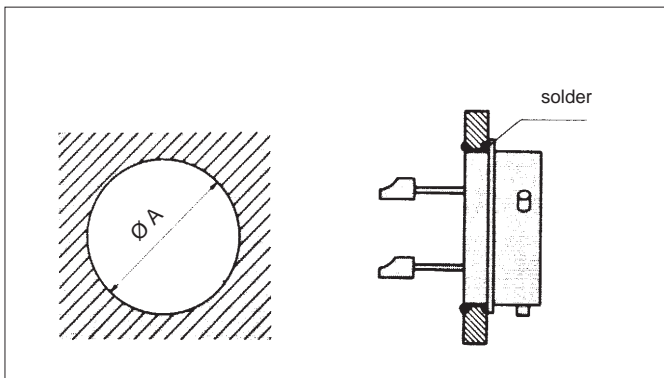

shell size	A
10SL	13.20 .52
12S	17.20 .68
14S	18.80 .74
16S	21.90 .86
18	25.20 .99
20	29.90 1.18
28	41.80 1.65

Hermetic square flange recep. type 02H

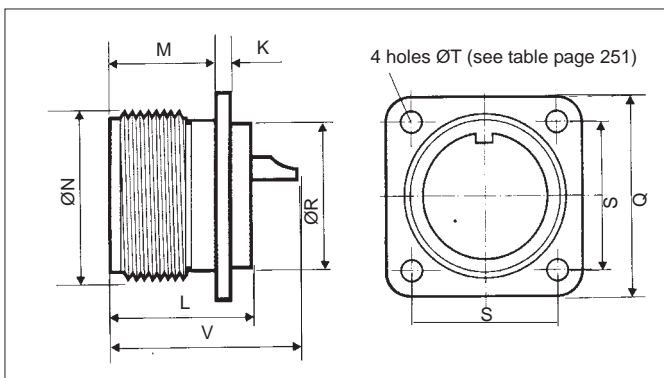

shell size	K	L	M	N	Q	R	S	V
10SL	1.60 .06	20.40 .80	16.55 .65	15.84 .62	25.25 .99	12.70 .50	18.25 .72	29.20 1.15
12S	1.60 .06	20.40 .80	16.55 .65	19.02 .75	27.60 1.08	16.70 .66	20.60 .81	29.20 1.15
14S	1.60 .06	20.40 .80	16.55 .65	22.19 .87	30.00 1.18	18.30 .72	23.00 .91	29.20 1.15
16S	1.60 .06	20.40 .80	16.55 .65	25.40 1.00	32.60 1.28	21.40 .84	24.60 .97	29.20 1.15
18	2.00 .08	25.15 .99	20.65 .81	28.50 1.12	35.00 1.38	24.70 .97	26.97 1.06	33.70 1.32
20	2.00 .08	25.15 .99	21.05 .83	31.70 1.25	37.40 1.47	29.40 1.15	29.40 1.16	33.70 1.35
28	2.00 .08	25.15 .99	21.05 .83	44.40 1.74	50.65 1.99	41.30 1.62	39.65 1.56	33.70 1.32

Panel cut-out

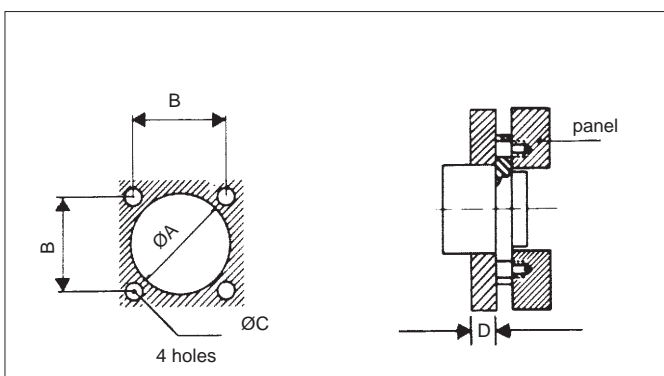

shell size	front of panel			rear of panel			
	A	B	C	A	B	C	D Max
10SL	13.20 .52	18.25 .72	3.80 .15	17.00 .67	18.25 .72	3.80 .15	6.00 .24
12S	17.20 .68	20.60 .81	3.80 .15	20.20 .79	20.60 .81	3.80 .15	6.00 .24
14S	18.80 .74	23.00 .91	3.80 .15	23.40 .92	23.00 .91	3.80 .15	6.00 .24
16S	21.90 .86	24.60 .97	3.80 .15	26.60 1.05	24.60 .97	3.80 .15	6.00 .24
18	25.20 .99	27.00 1.06	4.60 .18	29.70 1.17	27.00 1.06	4.60 .18	5.30 .21
20	29.90 1.18	29.40 1.16	4.60 .18	32.90 1.29	29.40 1.16	4.60 .18	5.30 .21
28	41.80 1.65	39.65 1.56	4.60 .18	45.60 1.79	39.65 1.56	4.60 .18	5.30 .21



891/2 Series

Hermetic solder fixing recep. type 05H

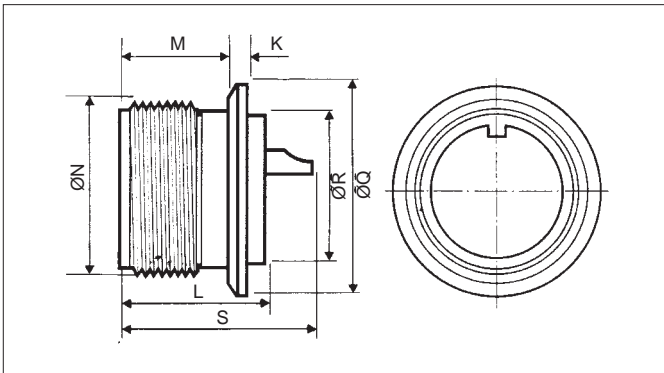

shell size	K	L	M	N	Q	R	S
10SL	1.60 .06	20.40 .80	16.55 .65	15.84 .62	22.00 .86	12.70 .50	29.20 1.15
12S	1.60 .06	20.40 .80	16.55 .65	19.02 .75	25.15 .99	16.70 .66	29.20 1.15
14S	1.60 .06	20.40 .80	16.55 .65	22.19 .87	28.35 1.11	18.30 .72	29.20 1.15
16S	1.60 .06	20.40 .80	16.55 .65	25.40 1.00	31.50 1.24	21.40 .84	29.20 1.15
18	2.00 .08	25.15 .99	20.65 .81	28.50 1.12	34.65 1.36	24.70 .97	33.70 1.32
20	2.00 .08	25.15 .99	21.05 .83	31.70 1.25	37.85 1.49	29.40 1.15	33.70 1.32
28	2.00 .08	25.15 .99	21.05 .83	44.40 1.74	50.55 1.99	41.30 1.62	33.70 1.32

Panel cut-out

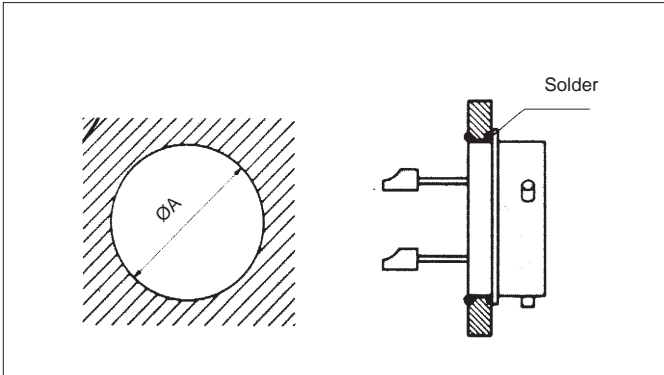

shell size	A
10SL	13.20 .52
12S	17.20 .68
14S	18.20 .74
16S	21.90 .86
18	25.20 .99
20	29.90 1.18
28	41.80 1.65

Simple backnuts

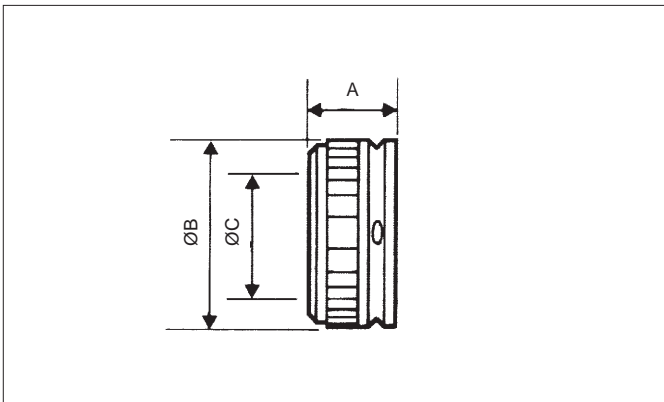

shell size	part number	A	B Max	C
10/12	8950-E-12 †	13.00 .52	19.20 .76	11.60 .46
14	8950-E-14	13.00 .52	22.20 .87	14.40 .57
16	8950-E-16	13.00 .52	25.20 .99	16.70 .66
18	8950-E-18	13.00 .52	28.50 1.12	19.80 .78
20	8950-E-20	13.00 .52	33.30 1.31	24.20 .95
22	8950-E-22	13.00 .52	34.90 1.37	26.60 1.05
24	8950-E-24	13.00 .52	39.80 1.57	29.55 1.16
28	8950-E-28	13.00 .52	45.00 1.77	35.60 1.40

† : when using with 892.04 (ESC) connectors, -04 should be added to the backshell number e.g. 8950-E-12-04 (size 12 only)

Straight cable clamps

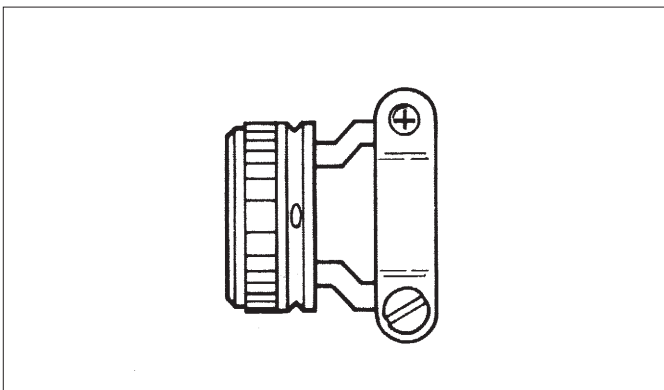

shell size	part number
10/12	8950-F-12 †
14	8950-F-14
16	8950-F-16
18	8950-F-18
20	8950-F-20
22	8950-F-22
24	8950-F-24
28	8950-F-28

† : when using with 892.04 (ESC) connectors, -04 should be added to the backshell number e.g. 8950-F-12-04 (size 12 only)



891/2 Series

Straight adapters

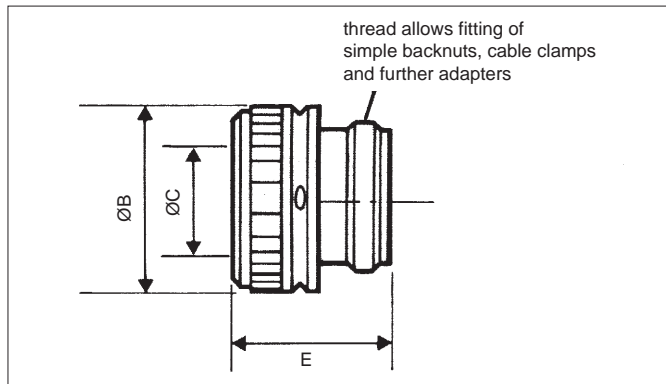

shell size	part number	B Max	C	E Max
10/12	8950-A-12 †	19.90 .76	11.60 .46	23.25 .92
14	8950-A-14	22.20 .87	14.40 .57	23.25 .92
16	8950-A-16	25.20 .99	16.70 .66	23.25 .92
18	8950-A-18	28.50 1.12	19.80 .78	23.25 .92
20	8950-A-20	33.20 1.31	24.20 .95	23.25 .92
22	8950-A-22	34.90 1.37	26.60 1.05	23.25 .92
24	8950-A-24	39.80 1.57	29.55 1.16	23.25 .92
28	8950-A-28	45.00 1.77	35.60 1.40	26.45 1.04

† : when using with 892.04 (ESC) connectors, -04 should be added to the backshell number e.g. 8950-E-12-04 (size 12 only)

Elbow adapters

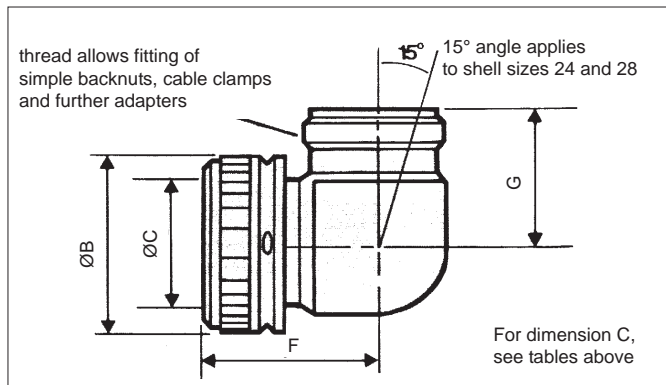

shell size	part number	B Max	F Max	G Max
10/12	8950-14-12 †	19.90 .76	24.80 .98	17.50 .69
14	8950-14-14	22.20 .87	24.80 .98	18.50 .73
16	8950-14-16	25.20 .99	26.80 1.05	21.00 .83
18	8950-14-18	28.50 1.12	29.90 1.14	22.50 .89
20	8950-14-20	33.20 1.31	29.40 1.18	26.00 1.02
22	8950-14-22	34.90 1.37	32.40 1.28	26.00 1.02
24	8950-14-24	39.80 1.57	24.10 1.74	39.60 1.56
28	8950-14-28	45.00 1.77	35.10 1.30	39.60 1.56

† : when using with 892.04 (ESC) connectors, -04 should be added to the backshell number e.g. 8950-E-12-04 (size 12 only)

Parking receptacles

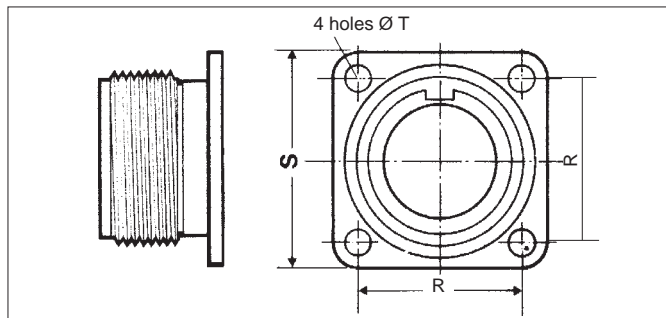

shell size	part number	shell size	part number
10SL	8950-40	18	8950-45
12S	8950-41	20	8950-46
14S	8950-42	22	8950-47
16S	8950-44	24	8950-48
16	8950-43	28	8950-49

Common dimensions with square flange receptacle (page 276)

Metal protective caps

temperature class	10SL	12S	14S	16S	16	18	20	22	24	28
1	8950-60	8950-61	8950-62	8950-63	8950-64	8950-65	8950-66	8950-67	8950-68	8950-69
2	8950-60	8950-61	8950-62	8950-63	8950-64	8950-65	8950-66	8950-67	8950-68	8950-69

Nuts for jam nut receptacles

temperature class	10SL	12S	14S	16S	16	18	20	22	24	28
1	8950-339	8950-340	8522-843	8522-844	8522-844	8522-845	8522-846	8522-847	8522-848	8522-341
2	8950-339	8950-340	8522-843	8522-844	8522-844	8522-845	8522-846	8522-847	8522-848	8550-341

Gaskets for jam nut receptacles

temperature class	10SL	12S	14S	16S	16	18	20	22	24	28
1	8950-4731	8950-4732	8950-4733	8950-4734	8950-4734	8950-4735	8950-4736	8950-4737	8950-4738	8950-4739
2	8950-4731	8950-4732	8950-4733	8950-4734	8950-4734	8950-4735	8950-4736	8950-4737	8950-4738	8950-4739

Gaskets for square flange receptacles

temperature class	10SL	12S	14S	16S	16	18	20	22	24	28
1	8950-241	8950-242	8950-243	8950-244	8950-244	8950-245	8950-246	8950-333	8950-247	8950-248
2	8950-241	8950-242	8950-243	8950-244	8950-244	8950-245	8950-246	8950-333	8950-247	8950-248